

FCC CFR47 CERTIFICATION
PARTS 22, 90
TEST REPORT
FOR
CELLULAR & LAND MOBILE RADIO REPEATER

FCC ID:OJFLITENNA0LF0SB0

ISSUE DATE: OCTOBER 23, 2000

Prepared for

FOXCOM WIRELESS LTD.
Ofek One Center Building B,
Northern Industrial Zone
Lod, Israel 71293

Tested by

COMPLIANCE CERTIFICATION SERVICES, INC.
1366 BORDEAUX DRIVE
SUNNYVALE, CA 94089, USA
TEL: (408) 752-8166
FAX: (408) 752-8168

TABLE OF CONTENTS		PAGE
1. FCC CERTIFICATION INFORMATION		1
2. TEST FACILITY		4
3. ACCREDITATION AND LISTING		4
4. MEASUREMENT INSTRUMENTATION.....		4
5. MEASURING INSTRUMENT CALIBRATION		4
6. UNITS OF MEASUREMENT		4
7. FCC 15.207 & 15.209		5
8. TEST EQUIPMENT LIST.....		6
9. EUT SETUP PHOTOS.....		7
10. EXTERNAL I/O CABLE CONSTRUCTION DESCRIPTION.....		8
11. CONFIGURATION BLOCK DIAGRAM.....		9
12. PART 2: CERTIFICATION TEST REQUIREMENT:.....		9
SECTION 2.1046: RF POWER OUTPUT		9
SECTION 2.1047: MODULATION CHARACTERISTICS		10
SECTION 2.1049: OCCUPIED BANDWIDTH.....		10
SECTION 2.1051: SPURIOUS EMISSION AT ANTENNA TERMINALS.....		10
SECTION 2.1053: FIELD STRENGTH OF SPURIOUS RADIATION.....		11
SECTION 2.1055: FREQUENCY STABILITY		14
CHART OF PLOTS:.....		14

1. FCC CERTIFICATION INFORMATION

The following information is in accordance with FCC Rules, 47CFR Part2, Subpart J, Sections 2.1033 – 2.1055.

2.1033(c)(1) Applicant: Foxcom Wireless Ltd.
 Ofek One Center Building B,
 Northern Industrial Zone
 Lod, Israel 71293

Contact person: Shlomo Cohen
 Telephone number: 972-8-9183818

2.1033(c)(2) FCC ID: OJFLITENNA0LF0SB0

2.1033(c)(3) Instructions/Installation Manual
 Refer to **Attachment:** User’s Manual.

2.1033(c)(4) Type of emissions

, DXW (TDMA), F9W (CDMA), F8W(AMPS), F1D (Paging), GXW (iDEN), F3E (SMR), F3E (SMR)

2.1033(c)(5) Frequency Range

DOWNLINK	SERVICE
869-894 MHz	AMPS/TDMA/CDMA 800
851-869 MHz	LMR/iDEN 800
935-940 MHz	SMR 900
928-940 MHz	Paging 900

2.1033(c)(6) Range of Operation Power

14 dBm – 21 dBm maximum output, depending on modulation. Refer to Litenna Data Sheet, separate attachment, composite 1 carrier

(F9W) CDMA : 13.7 dBm (23.4 mW)	(F8W) AMPS: 20 dBm (100 mW)
(DXW) TDMA: 21.0 dBm (126 mW)	(GXW) iDEN: 21 dBm (126 mW)
(F3E) SMR: 20.4 dBm (109.6 mW)	(F3E) LMR : 20 dBm (100 mW)
(F1D) Paging 20 dBm (100 Mw)	

2.1033(c)(7) Maximum Power Rating

0.126 WATTS (21 dBm)

Section 22.913(a); Maximum ERP. The effective radiated power (ERP) of base

transmitters and cellular repeaters must not exceed 500 Watts.

Section 24.13(a,b); Maximum ERP. The effective radiated power (ERP) of 901-902 MHz radios and mobile radios must not exceed 7 Watts.

Section 90.205(i,j): Maximum Power. 30-500 watts.

2.1033(c)(8) Applied voltage and currents into the final transistor elements

Refer to schematic

2.1033(c)(9) Tune-up/Optimizations Procedure

Refer to installation manual

2.1033(c)(10) Complete Circuit Diagrams and Functional Diagram

Refer to Schematics and Block Diagram . Confidentiality is requested for these items.

2.1033(c)(10a) Means for Frequency Stabilization

Not Applicable. Eut is an amplifier type repeater.

2.1033(c)(10b) Means for Suppressing of Spurious radiation.

SAW filter. See Repeater description.

2.1033(c)(10c) Means for Limiting Modulation.

Not Applicable. Eut is a repeater.

2.1033(c)(10d) Means for Limiting Power.

Software control

2.1033(c)(11) Equipment Identification

Refer to separate Word attachment

2.1033(c)(12) Photographs

Refer to separate Word attachment

2.1033(c)(13) Description of Digital Modulation Techniques

N/A EUT is repeater.

2.1033(c)(14) Standard Test Condition

The repeater was tested under the following conditions.

DC Supply from AC-DC adapter: 24 VDC

The amplifier was aligned and tuned up according to manufacturer’s alignment procedure, prior to testing. All data presented represents the worst case parameter being measured.

2.1033 Description of Various Base Station Configurations

Not Applicable.

2.1033 Use of Various Power Supplies

Not Applicable.

TYPE OF EQUIPMENT:	CELLULAR and Part 90 REPEATER
MEASUREMENT DISTANCE:	3 METER
TECHNICAL LIMIT:	FCC 22.359, 22.917
FCC RULES:	PART 22, , 90
EQUIPMENT AUTHORIZATION PROCEDURE	CERTIFICATION
MODIFICATIONS MADE ON EUT	<input type="checkbox"/> YES <input checked="" type="checkbox"/> NO

The above equipment was tested by Compliance Certification Services for compliance with the requirements set forth in the FCC CFR 47, Parts 2, 22 , and 90. The results of testing in this report apply to the product/system, which was tested only. Other similar equipment will not necessarily produce the same results due to production tolerance and measurement uncertainties.

T.N. Cokenias
Agent for Foxcom

2. TEST FACILITY

The open area test sites and conducted measurement facilities used to collect the radiated data are located at 561F Monterey Road, Morgan Hill, California, USA. The sites are constructed in conformance with the requirements of ANSI C63.7, ANSI C63.4 and CISPR Publication 22.

3. ACCREDITATION AND LISTING

The test facilities used to perform radiated and conducted emissions tests are accredited by National Voluntary Laboratory Accreditation Program for the specific scope of accreditation under Lab Code:200065-0 to perform Electromagnetic Interference tests according to FCC PART 15 AND CISPR 22 requirements. No part of this report may be used to claim or imply product endorsement by NVLAP or any agency of the US Government. In addition, the test facilities are listed with Federal Communications Commission (reference no: 31040/SIT (1300B3) and 31040/SIT(1300F2))

4. MEASUREMENT INSTRUMENTATION

Radiated emissions were measured with one or more of the following types of linearly polarized antennas: tuned dipole, biconical, log periodic, bi-log, ridged waveguide liner horn. EMI receivers were used for line conducted readings, spectrum analyzers with pre-selectors and quasi-peak detectors were used to perform radiated measurements. Receiving equipment (i.e., receiver, analyzer, quasi-peak adapter, pre-selector) and LISNs conform to CISPR specification for "Radio Interference Measuring Apparatus and Measurement Methods," Publication 16.

Calibrated wideband preamplifiers, coaxial cables, and coaxial attenuators are also used for making measurements.

5. MEASURING INSTRUMENT CALIBRATION

The measuring equipment, which was utilized in performing the tests documented herein, has been calibrated in accordance with the manufacturer's recommendations for utilizing calibration equipment, which is traceable to recognized national standards.

6. UNITS OF MEASUREMENT

Measurements of radiated interference are reported in terms of dB(uV/m) at a specified distance. The indicated readings on the spectrum analyzer were converted to dB(uV/m) by use of appropriate conversion factors. Measurements of conducted interference are reported in terms of dB(uV).

The field strength is calculated by adding the Antenna Factor and Cable Factors, then by subtracting the Amplifier Gain from the measured reading. The basic equation with a sample calculation is as follows:

$$FS = RA + AF + CF - AG$$

Where FS = Field Strength
 RA = Receiver Amplitude
 AF = Antenna Factor
 CF = Cable Attenuation Factor
 AG = Amplifier Gain

Assume a receiver reading of 52.5 dBuV is obtained. The Antenna Factor of 7.4dB/m and a Cable Factor of 1.1dB is added. The Amplifier Gain of 29 dB is subtracted, giving a field strength of 32 dBuV/m. The 32 dBuV/m value was mathematically converted to its corresponding level in uV/m.

$$FS = 52.5 + 7.4 + 1.1 - 29 = 32 \text{ dBuV/m}$$

$$\text{Level in uV/m} = \text{Common Antilogarithm} [(32 \text{ dBuV/m})/20] = 39.8 \text{ uV/m}$$

7. FCC 15.207 & 15.209

NOT APPLICABLE – no digital devices, no unintentional radiators in EUT

8. TEST EQUIPMENT LIST

Equipment	Manufacturer	Model No.	Serial No.	Site	Cal Date	Due Date
Receiver	H.P.	8546A	3520A00259	A	03/00	03/01
Bilog Antenna	CHASE	CBL6112	2049	A	05/00	05/01
Spectrum Analyzer	H.P.	8566B	3014A06685	N/A	07/00	07/01
Spectrum Analyzer	H.P.	8593EM	3710A00205	N/A	05/00	05/01
Horn Antenna	EMCO	3115	9001-3245	N/A	12/97	12/00
Pre-Amp	H.P. (1-26.5GHz)	8449B	3008A00369	N/A	04/00	04/01
Power Meter	H.P.	436A	2709A29209	N/A	02/00	02/01
Power Sensor	H.P.	8482A	2349A08568	N/A	02/00	02/01
Horn Antenna	ARA	MWH-1826/B	1013	N/A	7/28/00	7/28/01

B) SUPPORT EQUIPMENT

Device Type	Manufacturer	Model Number	Serial No.
SIGNAL GENERATOR	HP	83732B	N/A
SIGNAL GENERATOR	Rohde & Schwarz	SMY01	DE12311
SIGNAL GENERATOR	Rohde & Schwarz	SMIQ03	N/A
SIGNAL GENERATOR	Rohde & Schwarz	SMIQ03	N/A

9. EUT SETUP PHOTOS

- refer to separate attachment

10. EXTERNAL I/O CABLE DESCRIPTION

CABLE NO:1	
I/O Port: : ANTENNA OUT	Number of I/O ports of this type: 4
Number of Conductors: 4	Connector Type: N-TYPE
Capture Type: SCREW IN	Type of Cable used: SHIELDED (to analyzer)
Cable Connector Type: METAL	Cable Length: 1.5 m (to analyzer)
Bundled During Tests: NO	Data Traffic Generated: YES
Remark: 3 terminated 50 ohms, 4th to spectrum analyzer	

CABLE NO: 2	
Optical fiber from base to remote unit	
Remark: N/A	

CABLE NO: 3	
I/O Port: : RF IN from building basestation	Number of I/O ports of this type: 1
Number of Conductors: 2	Connector Type: N-TYPE
Capture Type: SCREW IN	Type of Cable used: SHIELDED
Cable Connector Type: METAL	Cable Length: 1.5 M
Bundled During Tests: NO	Data Traffic Generated: YES
Remark: N/A	

11. CONFIGURATION BLOCK DIAGRAM

(two gen for intermod test)

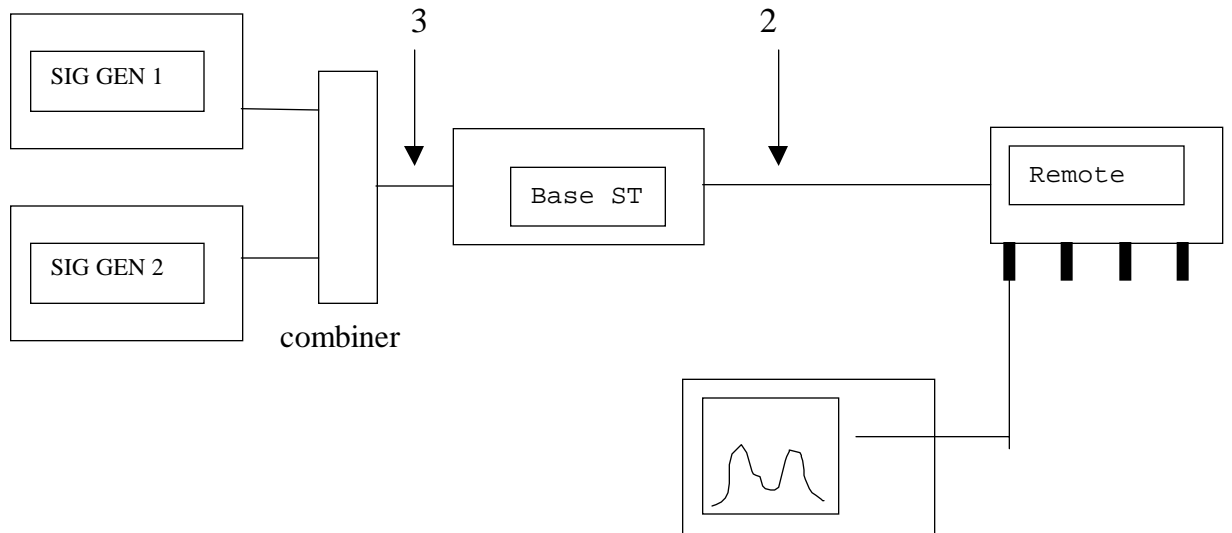

FIGURE 1.

12. PART 2: CERTIFICATION TEST REQUIREMENT:

SECTION 2.1046: RF POWER OUTPUT

Test Setup: Refer to figure #1

Minimum requirement:

Section 22.913(a); Maximum ERP. The effective radiated power (ERP) of base transmitters and cellular repeaters must not exceed 500 Watts. The ERP of mobile transmitters and auxiliary test transmitters must not exceed 7 Watts.

Test procedure:

Figure 1. shows the setup for conducted RF power output measurement. RF power output was measured with a power meter. Set the power amplifier to the maximum output gain.

Test Result: maximum measured 21 dBm = .126 watts.

SECTION 2.1047: MODULATION CHARACTERISTICS

Not applicable. EUT is a repeater.

SECTION 2.1049: OCCUPIED BANDWIDTH

Test Setup: Refer to figure #1

Minimum Requirement:

Section 2.1049(i); transmitters designed for other types of modulation-when modulated by an appropriate signal of sufficient amplitude to be representative of the type of service in which used. A description of the input signal should be supplied.

Test Procedure:

The Eut's occupied bandwidth is compared to the input source plot (signal generator) and output plot (power amplifier) and check that the input signal bandwidth is not greater at the output of amplifier.

Test results:

Plots were made for the output of the amplifier and another for the input from signal generator. was used for this test. Refer to chart designating plots.

SECTION 2.1051: SPURIOUS EMISSION AT ANTENNA TERMINALS

Test Setup: Refer to figure #1

Minimum Requirement:

Section 22.917(e):

For transmitters the magnitude of each spurious, harmonic, and intermodulation emissions that can be detected when the equipment is operated under conditions specified in the instruction manual and/or alignment procedure, shall not be more than $43 + 10 \log (P)$ dBc below the mean power output, which is equivalent to -13 dBm.

Section 22.917(f):

Measured at REV transmit antenna with 849MHz. Input.

Test Procedure:

Scan Eut from 1MHz to the 10th harmonic of carrier and check for spurious, harmonic, and intermodulation emissions. Set the **RES Bw**: 30kHz, offset analyzer for external attenuation and using the **DISPLAY LINE** place it at -13 dBm. Use enough attenuation to prevent overload on the spectrum analyzer input, which can cause overload..

Test results:

Plots were made for the output of the amplifier and another for the input from signal generator. was used for this test. Refer to chart designating plots.

SECTION 2.1053: FIELD STRENGTH OF SPURIOUS RADIATION

Measurement Equipment Used:

HP 8593EM Spectrum Analyzer

HP 8449 B Preamplifier, 1-26 GHz

ARA DRG-118/A Double Ridged Horn antenna, 1 - 18 GHz

QIM "The Workhorse" low loss cable, 9 ft (loss: 0.85 dB/ft@ 26 GHz)

ARA MWH-1826/B Horn antenna 18/26GHz

Test setup:

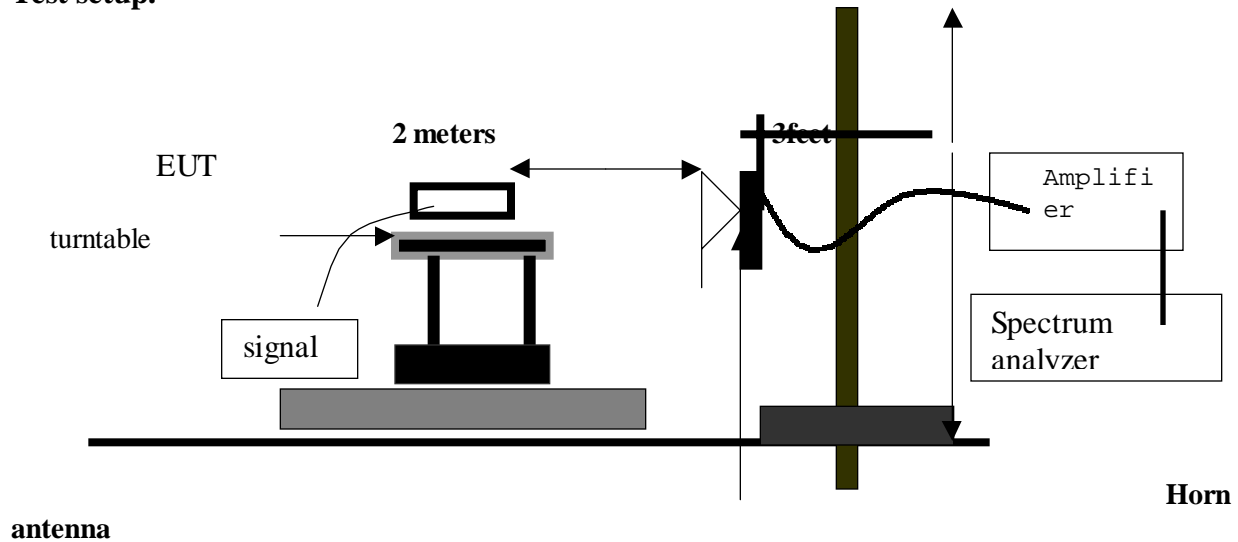

Radiated Emissions Configuration

Minimum Requirement:

Section 22.917(e):

The magnitude of each spurious and harmonic emissions detected as being radiated from the EUT must be at a level no more than $43 + 10 \log$ (mean output power, watts) dB below the mean power output (-13dBm).

Resultant radiated field at 3 meters from -13dBm source feeding isotropic antenna: 82 dBuV/m.

Test procedure:

1m test

EUT antenna output was terminated with a 50-ohm load. The EUT was placed on a outdoors-wooden table. The search antenna placed 1m from the EUT. With the transmitter operating at full power the turntable was slowly rotated to locate the direction of maximum emission. Once maximum direction is determined, the search antenna was raised and lowered in both vertical and horizontal polarization.

Test Result:

Please refer to spreadsheet below.

COMPLIANCE ENGINEERING SERVICES, INC.												
Harmonic Emissions												
22.917 10/05/00											Pete Krebill	
											A site (1.0 Meter)	
FOXCOM LITENNA CDMA/TDMA/AMPS 800												
fo= 892.0 MHz												
F(MHz)	READING		AF	CL	AMP	DIST	HPF	TOTAL		LIMIT	MARGIN	
	(dBuV)							(dB)	(dB)		(dB)	(dB)
	Pk	Avg						Pk	Avg		Pk	Avg
1784V	29.2		26.8	2.52	-35.5	-9.54	4	17.48		82.2	-64.7	
1784H	29.48		26.8	2.52	-35.5	-9.54	4	17.76		82.2	-64.4	
2676V	28.32		30	3.06	-35.5	-9.54	1	17.34		82.2	-64.9	
2676H	28.83		30	3.06	-35.5	-9.54	1	17.85		82.2	-64.4	
3568V	26.12		33.2	3.96	-35.5	-9.54	1	19.24		82.2	-63	
3568H	28.1		33.2	3.96	-35.5	-9.54	1	21.22		82.2	-61	
4460V	32.58		32.3	5.04	-35.5	-9.54	1	25.88		82.2	-56.3	
4460H	31.16		32.3	5.04	-35.5	-9.54	1	24.46		82.2	-57.7	
5352V	30.43		35	5.4	-35.5	-9.54	1	26.79		82.2	-55.4	
5352H	29.71		35	5.4	-35.5	-9.54	1	26.07		82.2	-56.1	
6244V	29.42		35.3	5.76	-35.5	-9.54	1	26.44		82.2	-55.8	
6244H	27.49		35.3	5.76	-35.5	-9.54	1	24.51		82.2	-57.7	
7136V	31.47		36.4	6.12	-35.5	-9.54	1	29.95		82.2	-52.3	
7136H	30.47		36.4	6.12	-35.5	-9.54	1	28.95		82.2	-53.3	
8028V	30.26		37	7.46	-35.5	-9.54	1	30.68		82.2	-51.5	
8028H	32.36		37	7.46	-35.5	-9.54	1	32.78		82.2	-49.4	
8920V	31.01		38.2	7.92	-35.5	-9.54	1	33.09		82.2	-49.1	
8920H	31.82		38.2	7.92	-35.5	-9.54	1	33.9		82.2	-48.3	
NOTE: ALL READINGS MEASURED AT 1 METER. LIMIT IS BASE AT 1 METER DISTANCE												
DIST: Correction to extrapolate reading to 3m specification distance												
AF: Antenna Factor												
AMP: Pre-amp gain												
										ANALYZER SETTINGS		
										Res bw		Avg. bw

SECTION 2.1055: FREQUENCY STABILITY

NOT APPLICABLE – EUT is an amplifier-type repeater. No RF oscillators, no frequency determining circuits in EUT.

CHART OF PLOTS:

AMPS INTERMODS 882MHz, 892 MHz 3 dBm each input, 12.5 kHz FM, 1 kHz audio	1
AMPS OUT OF BAND	2,3
AMPS INTERMODS 891MHz, 892 MHz 3 dBm each input, 12.5 kHz FM, 1 kHz audio	4
AMPS OUT OF BAND 891/892 MHz	5,6
AMPS INTERMODS 892.5MHz, 893 MHz 3 dBm each input, 12.5 kHz FM, 1 kHz audio	7
AMPS INTERMODS 870MHz, 870.075 MHz 3 dBm each input, 12.5 kHz FM, 1 kHz audio	8
AMPS INTERMODS 870MHz, 871 MHz 3 dBm each input, 12.5 kHz FM, 1 kHz audio	9
AMPS INTERMODS 892MHz, 893 MHz 3 dBm each input, 12.5 kHz FM, 1 kHz audio	10
AMPS INTERMODS 892MHz, 893 MHz out of band	11,12
AMPS INTERMODS 870MHz, 871 MHz out of band	13
AMPS INTERMODS 870MHz, 871 MHz out of band	14,
AMPS 892 MHz OUTPUT	15
AMPS 892 MHz INPUT	16
CDMA 892 MHz, 888.25 MHz	17
CDMA 892 MHz, 888.25 MHz out of band	18,19
CDMA 871 MHz, 874.25 MHz	20
CDMA 871 MHz, 874.25 MHz out of band	21,22
TDMA 871 MHz, 871.09 MHz	23
TDMA 871 MHz, 871.09 MHz out of band	24,25
TDMA 893 MHz, 892.91 MHz	26
TDMA 893 MHz, 892.91 MHz out of band	27,28
16QAM 853MHz,853.105 MHz	29
16QAM 853MHz,853.105 MHz out of band	30,31
16QAM 866MHz,867 MHz	32
16QAM 866MHz,867 MHz out of band	33,34
	35

	36
TDMA 893 MHz, input	37
TDMA 893 MHz, output	38
CMDA 892 MHz output	39
CMDA 892 MHz input	40
iDEN 867.075MHz,867 MHz 12.5 kHz FM, 1 kHz audio	41
iDEN 867.075MHz,867 MHz out of band	42,43
iDEN 853 MHz,853.075 MHz 12.5 kHz FM, 1 kHz audio	44
iDEN 853 MHz,853.075 MHz out of band	45,46
iDEN 853 MHz,853.075 MHz output	47
iDEN 853 MHz,853.075 MHz input	48
PAGING SMR 939.925 MHz, 940 MHz 12.5 kHz FM	49
PAGING SMR 939.925 MHz, 940 MHz out of band	50,51
PAGING SMR 936.925 MHz, 937 MHz 12.5 kHz FM	52
PAGING SMR 936.925 MHz, 937 MHz out of band	53,54
PAGING SMR 930.925 MHz, 931 MHz 12.5 kHz FM	55
PAGING SMR 930.925 MHz, 931 MHz out of band	56,57
PAGING SMR 938 output	58
PAGING SMR 938 input	59