

FCC CFR47 CERTIFICATION
PARTS 22, 24, 90
TEST REPORT
FOR
CELLULAR & LAND MOBILE RADIO REPEATER

FCC ID: OJFLITENNA0DB0P1

ISSUE DATE: May 10, 2001

Prepared for

FOXCOM WIRELESS LTD.
Ofek One Center Building B,
Northern Industrial Zone
Lod, Israel 71293

Tested by

Electromagnetic Compatibility Test Facility of
Israel Testing Laboratories
(26 Hacharoshet, POB 211, Or Yehuda 60251, Israel)
is located at
Kfar Bin Nun, 99780 Israel
TEL: +972-8-9797799
FAX: +972-8-9797702

AND

Compliance Certification Services
561F Monterey Road
Morgen Hill, CA 95307, USA

TEL: (408) 463-0885
FAX: (408) 463-0888

TABLE OF CONTENTS		PAGE
1.	FCC CERTIFICATION INFORMATION	1
2.	TEST FACILITY	6
3.	ACCREDITATION AND LISTING	6
4.	MEASUREMENT INSTRUMENTATION.....	6
5.	MEASURING INSTRUMENT CALIBRATION	6
6.	UNITS OF MEASUREMENT	7
7.	FCC 15.207 & 15.209.....	7
8.	TEST EQUIPMENT LIST.....	8
9.	EUT SETUP PHOTOS.....	9
10.	EXTERNAL I/O CABLE CONSTRUCTION DESCRIPTION.....	13
11.	CONFIGURATION BLOCK DIAGRAM.....	14
12.	PART 2: CERTIFICATION TEST REQUIREMENT:.....	14
	SECTION 2.1046: RF POWER OUTPUT	14
	SECTION 2.1047: MODULATION CHARACTERISTICS	15
	SECTION 2.1049: OCCUPIED BANDWIDTH.....	15
	SECTION 2.1051: SPURIOUS EMISSION AT ANTENNA TERMINALS.....	17
	SECTION 2.1053: FIELD STRENGTH OF SPURIOUS RADIATION.....	18
	SECTION 2.1055: FREQUENCY STABILITY	19
	CHART OF PLOTS:.....	21
13.	RF HAZARD PER 1.1310: CALCULATION OF DISTANCE.....	16

1. FCC CERTIFICATION INFORMATION

The following information is in accordance with FCC Rules, 47CFR Part2, Subpart J, Sections 2.1033 – 2.1055.

2.1033(c)(1) Applicant: Foxcom Wireless Ltd.
 Ofek One Center Building B,
 Northern Industrial Zone
 Lod, Israel 71293

Contact person: Shlomo Cohen
 Telephone number: 972-8-9183818

2.1033(c)(2) FCC ID: OJFLITENNA0DB0P1

2.1033(c)(3) Instructions/Installation Manual
 Refer to **Attachment:** User’s Manual.

2.1033(c)(4) Type of emissions

DXW (TDMA), F9W (CDMA), F8W (AMPS), F1D (Paging), GXW (iDEN),
 F3E (LMR), F3E (SMR), GXW (GSM),

2.1033(c)(5) Frequency Range

DOWNLINK	SERVICE
869-894 MHz	AMPS/TDMA/CDMA 800
851-869 MHz	LMR/iDEM 800
935-941 MHz	SMR 900
929-942 MHz	Paging 900
1930-1990 MHz	TDMA/CDMA/GSM 1900
935-960 MHz	GSM 900
1805-1880 MHz	GSM 1800

2.1033(c)(6) Range of Operation Power

18 dBm – 24 dBm maximum output for Low Frequency and 18 dBm – 21 dBm maximum output for High Frequency, depending on modulation. Refer to Litenna Data Sheet, separate attachment, composite 1 carrier.

2.1033(c)(7) Maximum Power Rating

Modulation	Specification (dBm)	I.T.L Data (dBm)	I.T.L Data (W)
(F9W) CDMA 800	18	18.2	0.066
(DXW) TDMA 800	24	24.3	0.269
(F8W) AMPS 800	24	24.3	0.269
(F3E) LMR 800	24	24.5	0.282
(GXW) iDEN 800	24	24.8	0.302
(F3E) SMR 900	24	24.5	0.282
(F1D) Paging 900	24	24.6	0.288
(F9W) CDMA 1900	18	18.2	0.066
(DXW) TDMA 1900	21	21.8	0.151
(GXW) GSM 1900	21	21.6	0.145
(GXW) GSM 900	24	24	0.251
(GXW) GSM 1800	21	22.3	0.170

Section 22.913(a); Maximum ERP. The effective radiated power (ERP) of base transmitters and cellular repeaters must not exceed 500 Watts

Section 90.205(i,j): Maximum Power. 30-500 watts.

For AMPS/TDMA/CDMA 1900 and GSM 1800

Section 24.232(a,b); Maximum Power. Base stations must not exceed 100 Watts, mobile/portable stations must be less than 2 watts EIRP

2.1033(c)(8) Applied voltage and currents into the final transistor elements

Refer to schematic

2.1033(c)(9) Tune-up/Optimizations Procedure

Refer to installation manual

2.1033(c)(10) Complete Circuit Diagrams and Functional Diagram

Refer to Schematics and Block Diagram . Confidentiality is requested for these items.

2.1033(c)(10a) Means for Frequency Stabilization

Not Applicable. Eut is an amplifier type repeater.

2.1033(c)(10b) Means for Suppressing of Spurious radiation.

SAW filter. See Repeater description.

2.1033(c)(10c) Means for Limiting Modulation.

Not Applicable. Eut is a repeater.

2.1033(c)(10d) Means for Limiting Power.

Software control

2.1033(c)(11) Equipment Identification

Refer to separate Word attachment

2.1033(c)(12) Photographs

Refer to separate Word attachment

2.1033(c)(13) Description of Digital Modulation Techniques

N/A EUT is repeater.

2.1033(c)(14) Standard Test Condition

The repeater was tested under the following conditions.

DC Supply from AC-DC adapter: 24 VDC

The amplifier was aligned and tuned up according to manufacturer’s alignment procedure, prior to testing. All data presented represents the worst case parameter being measured.

2.1033 Description of Various Base Station Configurations

Not Applicable.

2.1033 Use of Various Power Supplies

Not Applicable.

TYPE OF EQUIPMENT:	CELLULAR and Part 90 REPEATER
MEASUREMENT DISTANCE:	3 METER
TECHNICAL LIMIT:	FCC 22.359, 22.917, 24.232,
FCC RULES:	PART 22, 24, 90
EQUIPMENT AUTHORIZATION PROCEDURE	CERTIFICATION
MODIFICATIONS MADE ON EUT	<input type="checkbox"/> YES <input checked="" type="checkbox"/> NO

The above equipment was tested by I.T.L (PRODUCT TESTING) Ltd EMI LABORATORY and Compliance Certification Services for compliance with the requirements set forth in the FCC CFR

47, Parts 2, 22, 24, and 90. The results of testing in this report apply to the product/system, which was tested only. Other similar equipment will not necessarily produce the same results due to production tolerance and measurement uncertainties.

T.N. Cokenias
Agent for Foxcom

Product Variation: Mudulite

MuduLite™ System Architecture

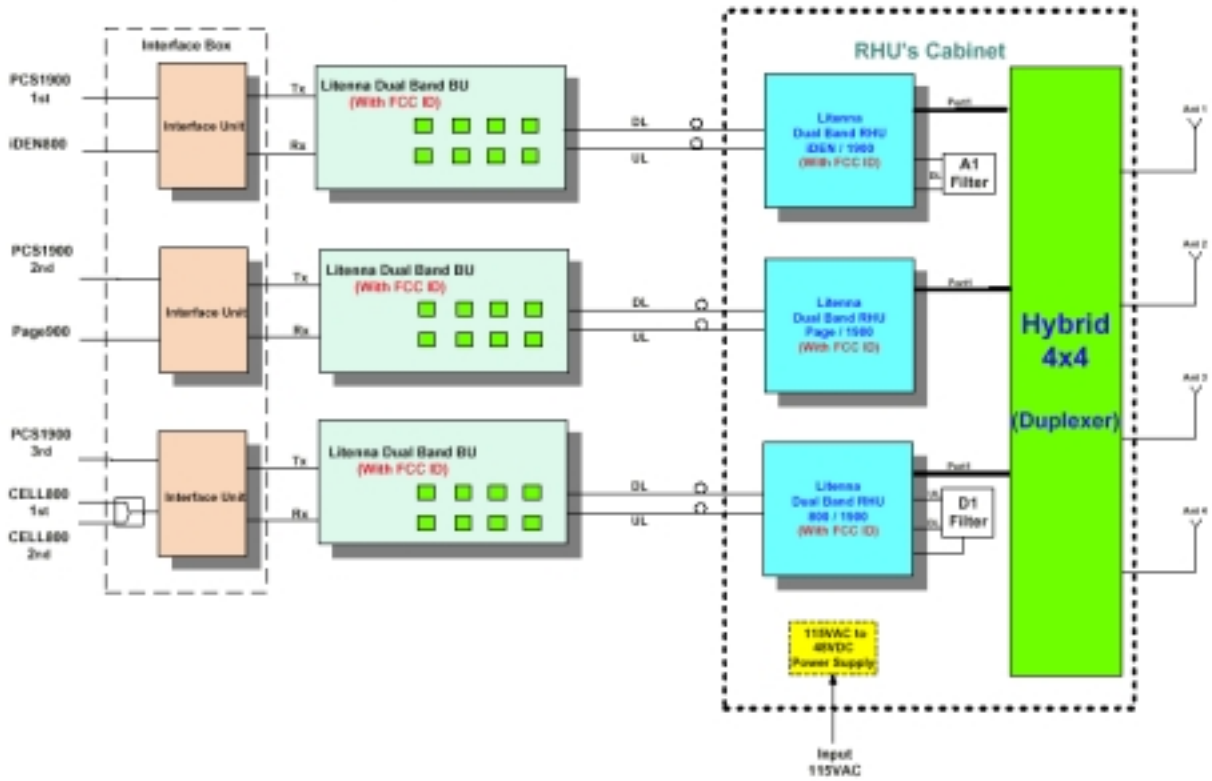

There is a product option called Mudulite. This consists of remote units placed in a cabinet, whose outputs are connected to a 4x4 duplexer unit. This Hybrid 4x4 is a passive filter network and does not affect any of the measured parameters for the remote units.

A separate set of photographs and a separate operational description are presented for the Mudulite option.

2. TEST FACILITY

The open area test sites and conducted measurement facilities used to collect the radiated data are located at Kfar Bin Nun 99780 ISRAEL. The sites are constructed in conformance with the requirements of, ANSI C63.4-1992 and CISPR Publication 22.

The open area test sites and conducted measurement facilities used to collect the radiated data are located at 561F Monterey Road, Morgan Hill, California, USA. The sites are constructed in conformance with the requirements of ANSI C63.7, ANSI C63.4 and CISPR Publication 22.

3. ACCREDITATION AND LISTING

The test facilities used to perform radiated and conducted emissions tests are accredited by National Voluntary Laboratory Accreditation Program for the specific scope of accreditation under Lab Code:200065-0 to perform Electromagnetic Interference tests according to FCC PART 15 AND CISPR 22 requirements. No part of this report may be used to claim or imply product endorsement by NVLAP or any agency of the US Government. In addition, the test facilities are listed with Federal Communications Commission (reference no: 31040/SIT (1300B3) and 31040/SIT(1300F2))

4. MEASUREMENT INSTRUMENTATION

Radiated emissions were measured with one or more of the following types of linearly polarized antennas: tuned dipole, biconical, log periodic, bi-log, ridged waveguide liner horn. EMI receivers were used for line conducted readings, spectrum analyzers with pre-selectors and quasi-peak detectors were used to perform radiated measurements. Receiving equipment (i.e., receiver, analyzer, quasi-peak adapter, pre-selector) and LISNs conform to CISPR specification for "Radio Interference Measuring Apparatus and Measurement Methods," Publication 16.

Calibrated wideband preamplifiers, coaxial cables, and coaxial attenuators are also used for making measurements.

5. MEASURING INSTRUMENT CALIBRATION

The measuring equipment, which was utilized in performing the tests documented herein, has been calibrated in accordance with the manufacturer's recommendations for utilizing calibration equipment, which is traceable to recognized national standards.

6. UNITS OF MEASUREMENT

Measurements of radiated interference are reported in terms of dB(uV/m) at a specified distance. The indicated readings on the spectrum analyzer were converted to dB(uV/m) by use of appropriate conversion factors. Measurements of conducted interference are reported in terms of dB(uV).

The field strength is calculated by adding the Antenna Factor and Cable Factors, then by subtracting the Amplifier Gain from the measured reading. The basic equation with a sample calculation is as follows:

$$FS = RA + AF + CF - AG$$

Where FS = Field Strength
 RA = Receiver Amplitude
 AF = Antenna Factor
 CF = Cable Attenuation Factor
 AG = Amplifier Gain

Assume a receiver reading of 52.5 dBuV is obtained. The Antenna Factor of 7.4dB/m and a Cable Factor of 1.1dB is added. The Amplifier Gain of 29 dB is subtracted, giving a field strength of 32 dBuV/m. The 32 dBuV/m value was mathematically converted to its corresponding level in uV/m.

$$FS = 52.5 + 7.4 + 1.1 - 29 = 32 \text{ dBuV/m}$$

$$\text{Level in uV/m} = \text{Common Antilogarithm} [(32 \text{ dBuV/m})/20] = 39.8 \text{ uV/m}$$

7. FCC 15.207 & 15.209

NOT APPLICABLE – no digital devices, no unintentional radiators in EUT

8. TEST EQUIPMENT LIST

Equipment	Manufacturer	Model No.	Serial No.	Cal Due Date
Signal Generator	HP	ESG-D3000A	4537231210	10/22/01
Signal Generator	HP	ESG-D4000A	4537230651	10/22/01
Signal Generator	HP	ESG-D3000A	4537040881	10/22/01
Signal Generator	HP	E4431B	45338220140	10/22/01
Signal Generator	HP	E4432B	GB39340672	10/21/01
Signal Generator	HP	E4432B	GB38450502	10/21/01
Spectrum Analyzer	HP	8562E	3846A01017	10/21/01
Spectrum Analyzer	HP	8592L	386A01204	01/31/02
Spectrum Analyzer*	HP	8593	3710A00205	05/01
Pre-amplifier*	HP	8449B	3008A00369	04/01
Horn Antenna, 1-18GH*	EMCO	3115	9001-3245	12/00
Horn Antenna, 18-26GH*	ARA	MWH 1826/B	1013	07/01
RF Signal Generator*	HP	83732B	US34490599	02/01

Note: Test equipment I.T.L. except *=CCS test equipment

9. EUT SETUP PHOTOS

Conducted Emissions/Intermodulation Tests, I.T.L



Radiated Emissions Set - Up, CCS

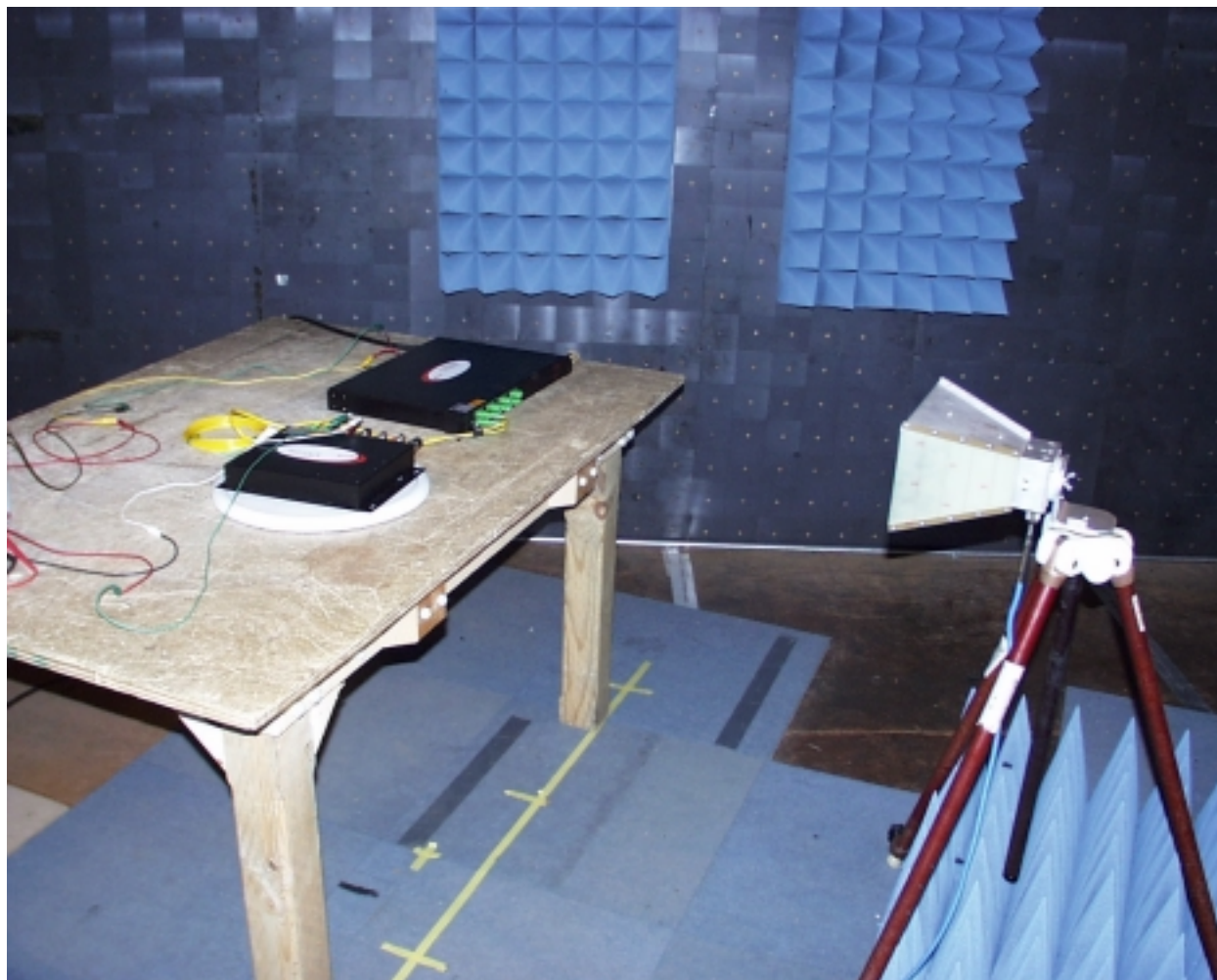

Substitution Set - Up, 1 – 18 GHz, CCS



Substitution Set - Up, 1 – 18 GHz, CCS

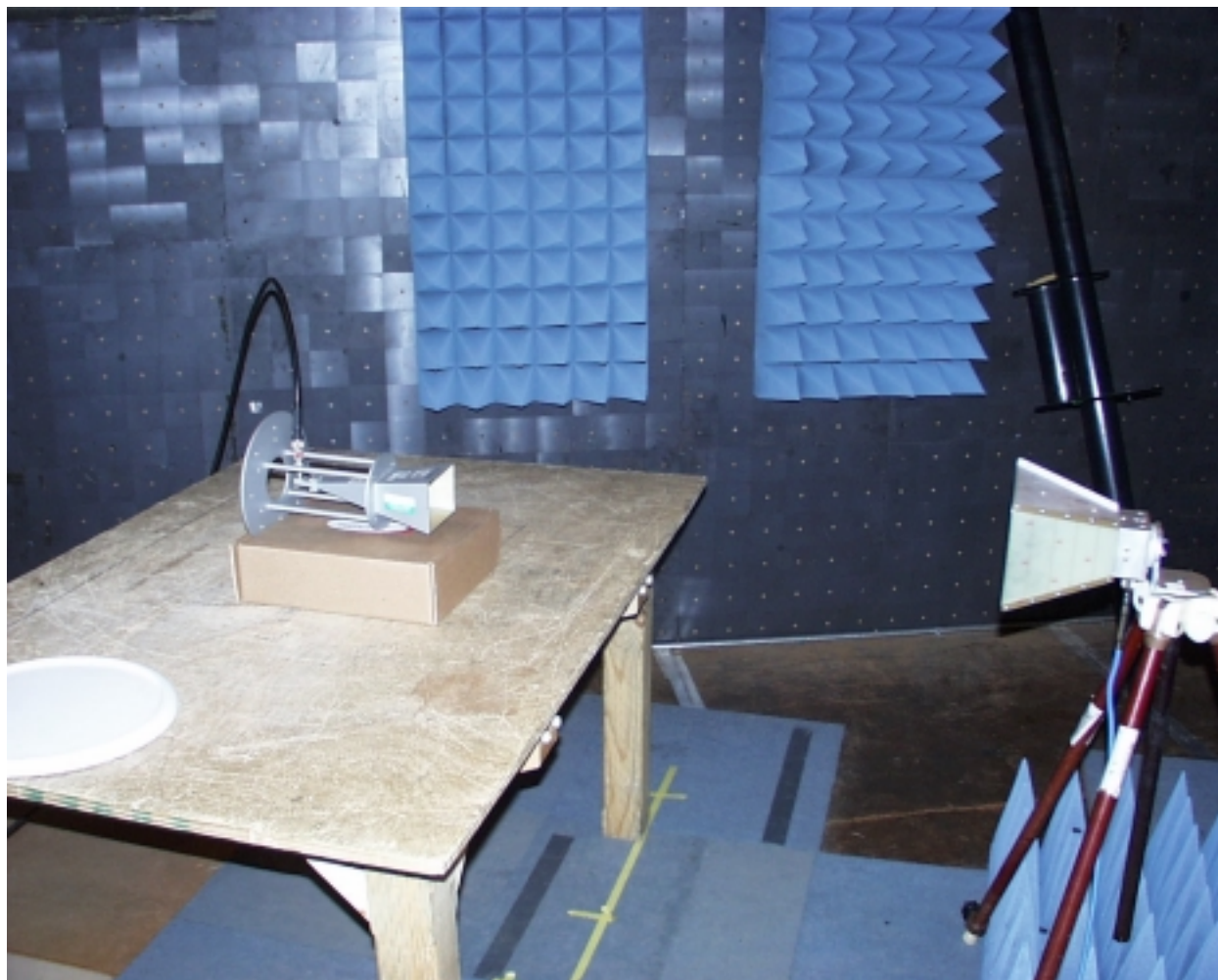

10. EXTERNAL I/O CABLE DESCRIPTION

CABLE NO:1	
I/O Port: : ANTENNA OUT	Number of I/O ports of this type: 4
Number of Conductors: 4	Connector Type: N-TYPE
Capture Type: SCREW IN	Type of Cable used: SHIELDED (to analyzer)
Cable Connector Type: METAL	Cable Length: 1.5 m (to analyzer)
Bundled During Tests: NO	Data Traffic Generated: YES
Remark: 3 terminated 50 ohms, 4th to spectrum analyzer	

CABLE NO: 2	
Optical fiber from base to remote unit	
Remark: N/A	

CABLE NO: 3	
I/O Port: : RF IN from building basestation	Number of I/O ports of this type: 1
Number of Conductors: 2	Connector Type: N-TYPE
Capture Type: SCREW IN	Type of Cable used: SHIELDED
Cable Connector Type: METAL	Cable Length: 1.5 M
Bundled During Tests: NO	Data Traffic Generated: YES
Remark: N/A	

11. CONFIGURATION BLOCK DIAGRAM

(two gen for intermod test)

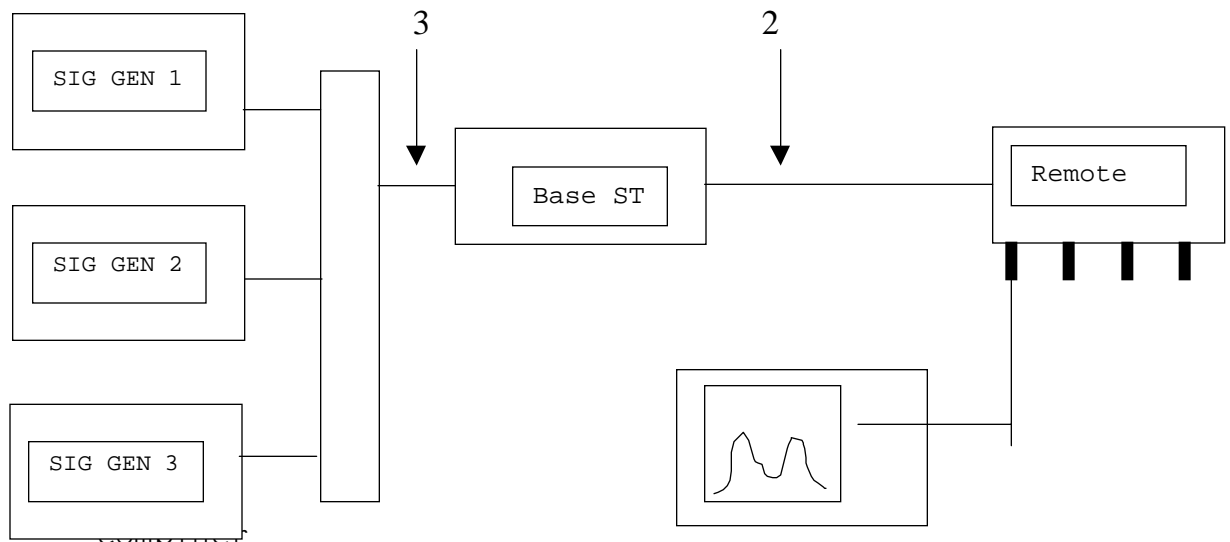

FIGURE 1.

12. PART 2: CERTIFICATION TEST REQUIREMENT:

SECTION 2.1046: RF POWER OUTPUT

Test Setup: Refer to figure #1

Minimum requirement:

Section 22.913(a); Maximum ERP. The effective radiated power (ERP) of base transmitters and cellular repeaters must not exceed 500 Watts. The ERP of mobile transmitters and auxiliary test transmitters must not exceed 7 Watts.

Section 24.232 Maximum Power. Base stations less than 300 watts, mobile/portable 2 watts EIRP.

Test procedure:

Figure 1. shows the setup for conducted RF power output measurement. RF power output was measured with a power meter. Set the power amplifier to the maximum output gain.

Test Result:

Modulation	Specification (dBm)	I.T.L Data (dBm)	I.T.L Data (W)
(F9W) CDMA 800	18	18.2	0.066
(DXW) TDMA 800	24	24.3	0.269
(F8W) AMPS 800	24	24.3	0.269
(F3E) LMR 800	24	24.5	0.282
(GXW) iDEN 800	24	24.8	0.302
(F3E) SMR 900	24	24.5	0.282
(F1D) Paging 900	24	24.6	0.288
(F9W) CDMA 1900	18	18.2	0.066
(DXW) TDMA 1900	21	21.8	0.151
(GXW) GSM 1900	21	21.6	0.145
(GXW) GSM 900	24	24	0.251
(GXW) GSM 1800	21	22.3	0.170

SECTION 2.1047: MODULATION CHARACTERISTICS

Not applicable. EUT is a repeater.

SECTION 2.1049: OCCUPIED BANDWIDTH

Test Setup: Refer to figure #1

Minimum Requirement:

Section 2.1049(i); transmitters designed for other types of modulation-when modulated by an appropriate signal of sufficient amplitude to be representative of the type of service in which used. A description of the input signal should be supplied.

Test Procedure:

The Eut's occupied bandwidth is compared to the input source plot (signal generator) and output plot (power amplifier) and check that the input signal bandwidth is not greater at the output of amplifier.

Test results:

Plots were made for the output of the amplifier and another for the input from signal generator. was used for this test. Refer to chart designating plots.

SECTION 2.1051: SPURIOUS EMISSION AT ANTENNA TERMINALS

Test Setup: Refer to figure #1

Minimum Requirement:

Section 22.917(e):

For transmitters the magnitude of each spurious, harmonic, and intermodulation emissions that can be detected when the equipment is operated under conditions specified in the instruction manual and/or alignment procedure, shall not be more than $43 + 10 \log (P)$ dBc below the mean power output, which is equivalent to -13 dBm.

Section 22.917(f):

Measured at REV transmit antenna with 849MHz. Input.

Test Procedure:

Scan Eut from 1MHz to the 10th harmonic of carrier and check for spurious, harmonic, and intermodulation emissions. Set the **RES Bw**: 30kHz, offset analyzer for external attenuation and using the **DISPLAY LINE** place it at -13 dBm. Use enough attenuation to prevent overload on the spectrum analyzer input, which can cause overload..

Test results:

Plots were made for the output of the amplifier and another for the input from signal generator. was used for this test. Refer to chart designating plots.

SECTION 2.1053: FIELD STRENGTH OF SPURIOUS RADIATION

Measurement Equipment Used:

HP 8593 EM Spectrum Analyzer 9kHz – 26.5 GHz

HP 8449 B Microwave pre-amplifier

EMCO 3115 Horn antenna, 1 - 18 GHz

ARA Horn antenna 18-26GHz

Test setup:

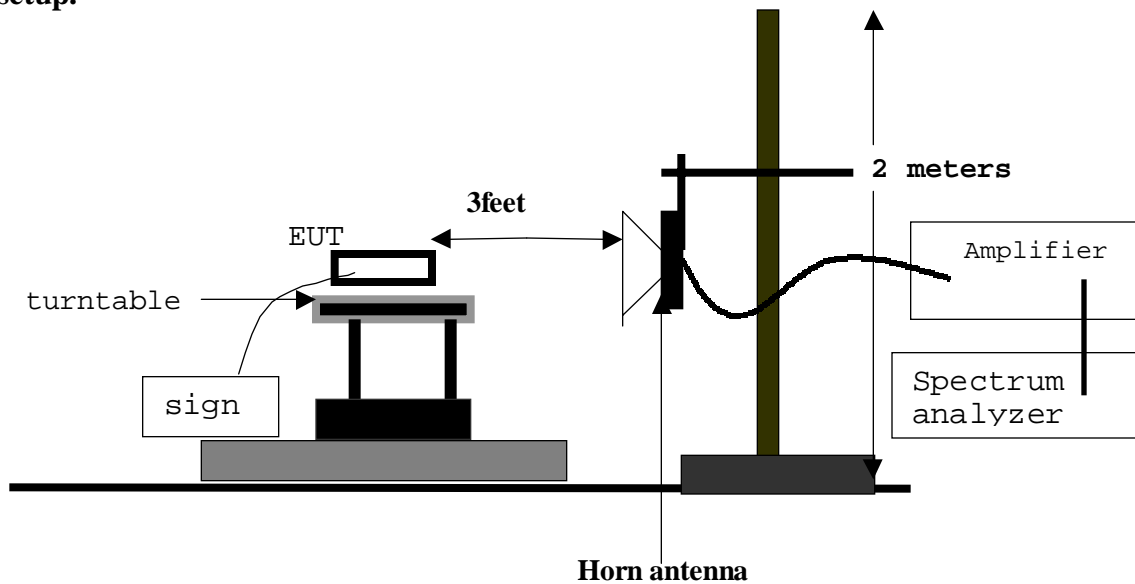

Radiated Emissions Configuration

Minimum Requirement:

Section 22.917(e):

The magnitude of each spurious and harmonic emissions detected as being radiated from the EUT must be at a level no more than $43 + 10 \log$ (mean output power, watts) dB below the mean power output (-13dBm).

Test procedure:

EUT antenna output was terminated with a 50-ohm load. The EUT was placed on a outdoors-wooden table. The search antenna placed 1-3m from the EUT. With the transmitter operating at full power the turntable was slowly rotated to locate the direction of maximum emission. Once maximum direction is determined, the search antenna was raised and lowered in both vertical and horizontal polarization.

The EUT was removed from the turntable and replaced with a linearly polarized antenna (horn antenna) connected to a calibrated RF signal generator. The RF generator was set to a measured emission frequency and the search antenna was raised and lowered to produce a maximum receiver reading. The generator output was increased to match the radiated emission reading measured previously, and the result expressed in dB EIRP or ERP, correcting for substitution antenna gain at each frequency.

Test Result:

Testing was **not performed** on the current product (FCC ID: OJFLITENNA0DB0P1). Construction of the 800/900 MHz and 1800/1900 remote units is virtually identical to those of a previously granted Litenna product. Test data taken on this previous products is presented here. The previous product was granted under *FCC ID: OJFLITENNA9B430P4*. Rationale for not repeating test was the wide margin between test results and required limits (over 28 dB in all cases)

Compliance Certification Services

Foxcom Wireless
 FCC ID:
 OJFLITENNA9B430P4

3/7/01

Pete
 Krebill

Frequency MHz	SA reading dBuV	Sig Gen dBm	CL dB	Gain dBi	Gain dBd	ERP dBm	Limit dBm	Margin dB
880								
1760V	43.7	-74.7	2.4	9	6.8	-70.3	-13	-57.3
2640V	28.7	-88.7	3	9	6.8	-84.9	-13	-71.9
3520V	27.5	-82.7	3.75	8	5.8	-80.65	-13	-67.65
4400H	29.3	-89.8	4.35	10.7	8.5	-85.65	-13	-72.65
5280V	26.9	-90	4.95	9.9	7.7	-87.25	-13	-74.25
6160V	29.1	-90	5.4	10.6	8.4	-87	-13	-74
7040V	29.6	-77.7	5.7	10.9	8.7	-74.7	-13	-61.7
7920V	29.5	-86.7	6	11.2	9	-83.7	-13	-70.7
8800V	29.7	-77.7	6.3	11	8.8	-75.2	-13	-62.2

Frequency MHz	SA reading dBuV	Sig Gen dBm	CL dB	Gain dBi	Gain dBd	ERP dBm	Limit dBm	Margin dB
1960								
3920H	36.4	-71.7	4.05	10	7.8	-67.95	-13	-54.95
5880V	32.3	-74.7	5.1	10.3	8.1	-71.7	-13	-58.7
7840V	31.5	-76.7	5.85	11.1	8.9	-73.65	-13	-60.65
9800V	31	-76.7	6.75	12	9.8	-73.65	-13	-60.65
11760V	30	-80.2	7.35	12	9.8	-77.75	-13	-64.75
13720V	32.2	-73.7	8.25	11.6	9.4	-72.55	-13	-59.55
15680V	33.2	-67.7	9	14.6	12.4	-64.3	-13	-51.3
17640V	32.8	-57.7	9.8	9	6.8	-60.7	-13	-47.7
19600V	36.7	-52.7	10.8	23.9	21.7	-41.8	-13	-28.8

SECTION 2.1055: FREQUENCY STABILITY

NOT APPLICABLE – EUT is an amplifier-type repeater. No RF oscillators, no frequency determining circuits in EUT.

CHART OF PLOTS:

AMPS INTERMODS, 2 Carriers (870 MHz & 870.5 MHz) at the bottom of the band and 1 Carrier (893MHz) at the top. All the Carriers are with FM modulation, DIV=12.5KHz, INT=1KHz, RBW=30 KHz, Spans=30 MHz	1
AMPS INTERMODS, 2 Carriers (870 MHz & 870.5 MHz) at the bottom of the band and 1 Carrier (893MHz) at the top. All the Carriers are with FM modulation, DIV=12.5KHz, INT=1KHz, RBW=30 KHz, Spans=60 MHz	2
AMPS INTERMODS, 2 Carriers (870 MHz & 870.5 MHz) at the bottom of the band and 1 Carrier (893MHz) at the top. All the Carriers are with FM modulation, DIV=12.5KHz, INT=1KHz, RBW=30 KHz, Spans=30 MHz to 10 GHz	3
AMPS INTERMODS, 1 Carrier (870 MHz) at the bottom and 2 Carriers (892.5 MHz & 893 MHz) at the top. All the Carriers are with FM modulation, DIV=12.5KHz, INT=1KHz, RBW=30 KHz, Spans=30 MHz	4
AMPS INTERMODS, 1 Carrier (870 MHz) at the bottom and 2 Carriers (892.5 MHz & 893 MHz) at the top. All the Carriers are with FM modulation, DIV=12.5KHz, INT=1KHz, RBW=30 KHz, Spans=60 MHz	5
AMPS INTERMODS, 1 Carrier (870 MHz) at the bottom and 2 Carriers (892.5 MHz & 893 MHz) at the top. All the Carriers are with FM modulation, DIV=12.5KHz, INT=1KHz, RBW=30 KHz, Spans=30 MHz to 10 GHz	6
AMPS OUTPUT	7
AMPS INPUT	8
CDMA INTERMODS, 2 Carriers (870 MHz & 870.5 MHz) at the bottom of the band and 1 Carrier (893MHz) at the top. All the Carriers are with CDMA modulation, RBW=30 KHz, Spans=30 MHz	9
CDMA INTERMODS, 2 Carriers (870 MHz & 870.5 MHz) at the bottom of the band and 1 Carrier (893MHz) at the top. All the Carriers are with CDMA modulation, RBW=30 KHz, Spans=60 MHz	10
CDMA INTERMODS, 2 Carriers (870 MHz & 870.5 MHz) at the bottom of the band and 1 Carrier (893MHz) at the top. All the Carriers are with CDMA modulation, RBW=30 KHz, Spans=30 MHz to 10 GHz	11

CDMA INTERMODS, 1 Carrier (870 MHz) at the bottom and 2 Carriers (892.5 MHz & 893 MHz) at the top. All the Carriers are with CDMA modulation, RBW=30 KHz, Spans=30 MHz	12
CDMA INTERMODS, 1 Carrier (870 MHz) at the bottom and 2 Carriers (892.5 MHz & 893 MHz) at the top. All the Carriers are with CDMA modulation, RBW=30 KHz, Spans=60 MHz	13
CDMA INTERMODS, 1 Carrier (870 MHz) at the bottom and 2 Carriers (892.5 MHz & 893 MHz) at the top. All the Carriers are with CDMA modulation, RBW=30 KHz, Spans=30 MHz to 10 GHz	14
CDMA OUTPUT	15
CDMA INPUT	16
TDMA INTERMODS, 2 Carriers (870 MHz & 870.5 MHz) at the bottom of the band and 1 Carrier (893MHz) at the top. All the Carriers are with TDMA modulation, RBW=30 KHz, Spans=30 MHz	17
TDMA INTERMODS, 2 Carriers (870 MHz & 870.5 MHz) at the bottom of the band and 1 Carrier (893MHz) at the top. All the Carriers are with TDMA modulation, RBW=30 KHz, Spans=60 MHz	18
TDMA INTERMODS, 2 Carriers (870 MHz & 870.5 MHz) at the bottom of the band and 1 Carrier (893MHz) at the top. All the Carriers are with TDMA modulation, RBW=30 KHz, Spans=30 MHz to 10 GHz	19
TDMA INTERMODS, 1 Carrier (870 MHz) at the bottom and 2 Carriers (892.5 MHz & 893 MHz) at the top. All the Carriers are with TDMA modulation, RBW=30 KHz, Spans=30 MHz	20
TDMA INTERMODS, 1 Carrier (870 MHz) at the bottom and 2 Carriers (892.5 MHz & 893 MHz) at the top. All the Carriers are with TDMA modulation, RBW=30 KHz, Spans=60 MHz	21
TDMA INTERMODS, 1 Carrier (870 MHz) at the bottom and 2 Carriers (892.5 MHz & 893 MHz) at the top. All the Carriers are with TDMA modulation, RBW=30 KHz, Spans=30 MHz to 10 GHz	22
TDMA OUTPUT	23
TDMA INPUT	24
LMR INTERMODS, 2 Carriers (852 MHz & 852.5 MHz) at the bottom of the band and 1 Carrier (868MHz) at the top. All the Carriers are with FM modulation, DIV=12.5KHz, INT=1KHz, RBW=30 KHz, Spans=25 MHz	25

LMR INTERMODS, 2 Carriers (852 MHz & 852.5 MHz) at the bottom of the band and 1 Carrier (868MHz) at the top. All the Carriers are with FM modulation, DIV=12.5KHz, INT=1KHz, RBW=30 KHz, Spans=50 MHz	26
LMR INTERMODS, 2 Carriers (852 MHz & 852.5 MHz) at the bottom of the band and 1 Carrier (868MHz) at the top. All the Carriers are with FM modulation, DIV=12.5KHz, INT=1KHz, RBW=30 KHz, Spans=30 MHz to 10 GHz	27
LMR INTERMODS, 1 Carrier (852 MHz) at the bottom and 2 Carriers (867.5 MHz & 868 MHz) at the top. All the Carriers are with FM modulation, DIV=12.5KHz, INT=1KHz, RBW=30 KHz, Spans=25 MHz	28
LMR INTERMODS, 1 Carrier (852 MHz) at the bottom and 2 Carriers (867.5 MHz & 868 MHz) at the top. All the Carriers are with FM modulation, DIV=12.5KHz, INT=1KHz, RBW=30 KHz, Spans=50 MHz	29
LMR INTERMODS, 1 Carrier (852 MHz) at the bottom and 2 Carriers (867.5 MHz & 868 MHz) at the top. All the Carriers are with FM modulation, DIV=12.5KHz, INT=1KHz, RBW=30 KHz, Spans=30 MHz to 10 GHz	30
LMR OUTPUT	31
LMR INPUT	32
iDEN INTERMODS, 2 Carriers (852 MHz & 852.5 MHz) at the bottom of the band and 1 Carrier (868MHz) at the top. All the Carriers are with 16QAM modulation, RBW=30 KHz, Spans=25 MHz	33
iDEN INTERMODS, 2 Carriers (852 MHz & 852.5 MHz) at the bottom of the band and 1 Carrier (868MHz) at the top. All the Carriers are with 16QAM modulation, RBW=30 KHz, Spans=50 MHz	34
iDEN INTERMODS, 2 Carriers (852 MHz & 852.5 MHz) at the bottom of the band and 1 Carrier (868MHz) at the top. All the Carriers are with 16QAM modulation, RBW=30 KHz, Spans=30 MHz to 10 GHz	35
iDEN INTERMODS, 1 Carrier (852 MHz) at the bottom and 2 Carriers (867.5 MHz & 868 MHz) at the top. All the Carriers are with 16QAM modulation, RBW=30 KHz, Spans=25 MHz	36
iDEN INTERMODS, 1 Carrier (852 MHz) at the bottom and 2 Carriers (867.5 MHz & 868 MHz) at the top. All the Carriers are with 16QAM modulation, RBW=30 KHz, Spans=50 MHz	37
iDEN INTERMODS, 1 Carrier (852 MHz) at the bottom and 2 Carriers (867.5 MHz & 868 MHz) at the top. All the Carriers are with 16QAM modulation, RBW=30 KHz, Spans=30 MHz to 10 GHz	38

iDEN OUTPUT	39
iDEN INPUT	40
SMR INTERMODS, 2 Carriers (936 MHz & 936.5 MHz) at the bottom of the band and 1 Carrier (940MHz) at the top. All the Carriers are with FM modulation, DIV=12.5KHz, INT=1KHz, RBW=30 KHz, Spans=25 MHz	41
SMR INTERMODS, 2 Carriers (936 MHz & 936.5 MHz) at the bottom of the band and 1 Carrier (940MHz) at the top. All the Carriers are with FM modulation, DIV=12.5KHz, INT=1KHz, RBW=30 KHz, Spans=50 MHz	42
SMR INTERMODS, 2 Carriers (936 MHz & 936.5 MHz) at the bottom of the band and 1 Carrier (940MHz) at the top. All the Carriers are with FM modulation, DIV=12.5KHz, INT=1KHz, RBW=30 KHz, Spans=30 MHz to 10 GHz	43
SMR INTERMODS, 1 Carrier (936MHz) at the bottom and 2 Carriers (939.5 MHz & 940 MHz) at the top. All the Carriers are with FM modulation, DIV=12.5KHz, INT=1KHz, RBW=30 KHz, Spans=25 MHz	44
SMR INTERMODS, 1 Carrier (936MHz) at the bottom and 2 Carriers (939.5 MHz & 940 MHz) at the top. All the Carriers are with FM modulation, DIV=12.5KHz, INT=1KHz, RBW=30 KHz, Spans=50 MHz	45
SMR INTERMODS, 1 Carrier (936MHz) at the bottom and 2 Carriers (939.5 MHz & 940 MHz) at the top. All the Carriers are with FM modulation, DIV=12.5KHz, INT=1KHz, RBW=30 KHz, Spans=30 MHz to 10 GHz	46
SMR OUTPUT	47
SMR INPUT	48
Paging INTERMODS, 2 Carriers (929 MHz & 929.5 MHz) at the bottom of the band and 1 Carrier (940MHz) at the top. All the Carriers are with FM modulation, DIV=12.5KHz, INT=1KHz, RBW=30 KHz, Spans=20 MHz	49
Paging INTERMODS, 2 Carriers (929 MHz & 929.5 MHz) at the bottom of the band and 1 Carrier (940MHz) at the top. All the Carriers are with FM modulation, DIV=12.5KHz, INT=1KHz, RBW=30 KHz, Spans=40 MHz	50
Paging INTERMODS, 2 Carriers (929 MHz & 929.5 MHz) at the bottom of the band and 1 Carrier (940MHz) at the top. All the Carriers are with FM modulation, DIV=12.5KHz, INT=1KHz, RBW=30 KHz, Spans=30 MHz to 10 GHz	51
Paging INTERMODS, 1 Carrier (929 MHz) at the bottom and 2 Carriers (939.5 MHz & 940 MHz) at the top. All the Carriers are with FM modulation, DIV=12.5KHz, INT=1KHz, RBW=30 KHz, Spans=20 MHz	52

Paging INTERMODS, 1 Carrier (929 MHz) at the bottom and 2 Carriers (939.5 MHz & 940 MHz) at the top. All the Carriers are with FM modulation, DIV=12.5KHz, INT=1KHz, RBW=30 KHz, Spans=40 MHz	53
Paging INTERMODS, 1 Carrier (929 MHz) at the bottom and 2 Carriers (939.5 MHz & 940 MHz) at the top. All the Carriers are with FM modulation, DIV=12.5KHz, INT=1KHz, RBW=30 KHz, Spans=30 MHz to 10 GHz	54
Paging OUTPUT	55
Paging INPUT	56
F3E INTERMODS, 2 Carriers (1931MHz & 1937MHz) at the bottom of the band and 1 Carrier (1988MHz) at the top. All the Carriers are with FM modulation, DIV=12.5KHz, INT=1KHz, RBW=1 MHz, Spans=100 MHz	57
F3E INTERMODS, 2 Carriers (1931MHz & 1937MHz) at the bottom of the band and 1 Carrier (1988MHz) at the top. All the Carriers are with FM modulation, DIV=12.5KHz, INT=1KHz, RBW=1 MHz, Spans=200 MHz	58
F3E INTERMODS, 2 Carriers (1931MHz & 1937MHz) at the bottom of the band and 1 Carrier (1988MHz) at the top. All the Carriers are with FM modulation, DIV=12.5KHz, INT=1KHz, RBW=1 MHz, Spans=30MHz to 20GHz	59, 60
F3E INTERMODS, 1 Carrier (1931MHz) at the bottom and 2 Carriers (1981MHz & 1988MHz) at the top. All the Carriers are with FM modulation, DIV=12.5KHz, INT=1KHz, RBW=1 MHz, Spans=100 MHz	61
F3E INTERMODS, 1 Carrier (1931MHz) at the bottom and 2 Carriers (1981MHz & 1988MHz) at the top. All the Carriers are with FM modulation, DIV=12.5KHz, INT=1KHz, RBW=1 MHz, Spans=200 MHz	62
F3E INTERMODS, 1 Carrier (1931MHz) at the bottom and 2 Carriers (1981MHz & 1988MHz) at the top. All the Carriers are with FM modulation, DIV=12.5KHz, INT=1KHz, RBW=1 MHz, Spans=30MHz to 20GHz	63, 64
F3E OUTPUT	65
F3E INPUT	66

CDMA INTERMODS, 2 Carriers (1931MHz & 1937MHz) at the bottom of the band and 1 Carrier (1988MHz) at the top. All the Carriers are with CDMA modulation, RBW=1 MHz, Spans=100 MHz	67
CDMA INTERMODS, 2 Carriers (1931MHz & 1937MHz) at the bottom of the band and 1 Carrier (1988MHz) at the top. All the Carriers are with CDMA modulation, RBW=1 MHz, Spans=200 MHz	68
CDMA INTERMODS, 2 Carriers (1931MHz & 1937MHz) at the bottom of the band and 1 Carrier (1988MHz) at the top. All the Carriers are with CDMA modulation, RBW=1 MHz, Spans=30MHz to 20GHz	69, 70
CDMA INTERMODS, 1 Carrier (1931MHz) at the bottom and 2 Carriers (1981MHz & 1988MHz) at the top. All the Carriers are with CDMA modulation, RBW=1 MHz, Spans=100 MHz	71
CDMA INTERMODS, 1 Carrier (1931MHz) at the bottom and 2 Carriers (1981MHz & 1988MHz) at the top. All the Carriers are with CDMA modulation, RBW=1 MHz, Spans=200 MHz	72
CDMA INTERMODS, 1 Carrier (1931MHz) at the bottom and 2 Carriers (1981MHz & 1988MHz) at the top. All the Carriers are with CDMA modulation, RBW=1 MHz, Spans=30MHz to 20GHz	73, 74
CDMA OUTPUT	75
CDMA INPUT	76
TDMA INTERMODS, 2 Carriers (1931MHz & 1937MHz) at the bottom of the band and 1 Carrier (1988MHz) at the top. All the Carriers are with TDMA modulation, RBW=1 MHz, Spans=100 MHz	77
TDMA INTERMODS, 2 Carriers (1931MHz & 1937MHz) at the bottom of the band and 1 Carrier (1988MHz) at the top. All the Carriers are with TDMA modulation, RBW=1 MHz, Spans=200 MHz	78
TDMA INTERMODS, 2 Carriers (1931MHz & 1937MHz) at the bottom of the band and 1 Carrier (1988MHz) at the top. All the Carriers are with TDMA modulation, RBW=1 MHz, Spans=30MHz to 20GHz	79, 80
TDMA INTERMODS, 1 Carrier (1931MHz) at the bottom and 2 Carriers (1981MHz & 1988MHz) at the top. All the Carriers are with TDMA modulation, RBW=1 MHz, Spans=100 MHz	81

TDMA INTERMODS, 1 Carrier (1931MHz) at the bottom and 2 Carriers (1981MHz & 1988MHz) at the top. All the Carriers are with TDMA modulation, RBW=1 MHz, Spans=200 MHz	82
TDMA INTERMODS, 1 Carrier (1931MHz) at the bottom and 2 Carriers (1981MHz & 1988MHz) at the top. All the Carriers are with TDMA modulation, RBW=1 MHz, Spans=30MHz to 20GHz	83, 84
TDMA OUTPUT	85
TDMA INPUT	86
GSM INTERMODS, 2 Carriers (1931MHz & 1937MHz) at the bottom of the band and 1 Carrier (1988MHz) at the top. All the Carriers are with GSM modulation, RBW=1 MHz, Spans=100 MHz	87
GSM INTERMODS, 2 Carriers (1931MHz & 1937MHz) at the bottom of the band and 1 Carrier (1988MHz) at the top. All the Carriers are with GSM modulation, RBW=1 MHz, Spans=200 MHz	88
GSM INTERMODS, 2 Carriers (1931MHz & 1937MHz) at the bottom of the band and 1 Carrier (1988MHz) at the top. All the Carriers are with GSM modulation, RBW=1 MHz, Spans=30MHz to 20GHz	89, 90
GSM INTERMODS, 1 Carrier (1931MHz) at the bottom and 2 Carriers (1981MHz & 1988MHz) at the top. All the Carriers are with GSM modulation, RBW=1 MHz, Spans=100 MHz	91
GSM INTERMODS, 1 Carrier (1931MHz) at the bottom and 2 Carriers (1981MHz & 1988MHz) at the top. All the Carriers are with GSM modulation, RBW=1 MHz, Spans=200 MHz	92
GSM INTERMODS, 1 Carrier (1931MHz) at the bottom and 2 Carriers (1981MHz & 1988MHz) at the top. All the Carriers are with GSM modulation, RBW=1 MHz, Spans=30MHz to 20GHz	93, 94
GSM OUTPUT	95
GSM INPUT	96

F3E INTERMODS, 2 Carriers (936 MHz & 936.5 MHz) at the bottom of the band and 1 Carrier (959MHz) at the top. All the Carriers are with FM modulation, DIV=12.5KHz, INT=1KHz, RBW=30 KHz, Spans=20 MHz	97
F3E INTERMODS, 2 Carriers (936 MHz & 936.5 MHz) at the bottom of the band and 1 Carrier (959MHz) at the top. All the Carriers are with FM modulation, DIV=12.5KHz, INT=1KHz, RBW=30 KHz, Spans=40 MHz	98
F3E INTERMODS, 2 Carriers (936 MHz & 936.5 MHz) at the bottom of the band and 1 Carrier (959MHz) at the top. All the Carriers are with FM modulation, DIV=12.5KHz, INT=1KHz, RBW=30 KHz, Spans=30 MHz to 10 GHz	99
F3E INTERMODS, 1 Carrier (936 MHz) at the bottom and 2 Carriers (958.5 MHz & 959 MHz) at the top. All the Carriers are with FM modulation, DIV=12.5KHz, INT=1KHz, RBW=30 KHz, Spans=20 MHz	100
F3E INTERMODS, 1 Carrier (936 MHz) at the bottom and 2 Carriers (958.5 MHz & 959 MHz) at the top. All the Carriers are with FM modulation, DIV=12.5KHz, INT=1KHz, RBW=30 KHz, Spans=40 MHz	101
F3E INTERMODS, 1 Carrier (936 MHz) at the bottom and 2 Carriers (958.5 MHz & 959 MHz) at the top. All the Carriers are with FM modulation, DIV=12.5KHz, INT=1KHz, RBW=30 KHz, Spans=30 MHz to 10 GHz	102
F3E OUTPUT	103
F3E INPUT	104
GSM INTERMODS, 2 Carriers (936 MHz & 936.5 MHz) at the bottom of the band and 1 Carrier (959MHz) at the top. All the Carriers are with 16QAM modulation, RBW=30 KHz, Spans=25 MHz	105
GSM INTERMODS, 2 Carriers (936 MHz & 936.5 MHz) at the bottom of the band and 1 Carrier (959MHz) at the top. All the Carriers are with 16QAM modulation, RBW=30 KHz, Spans=50 MHz	106
GSM INTERMODS, 2 Carriers (936 MHz & 936.5 MHz) at the bottom of the band and 1 Carrier (959MHz) at the top. All the Carriers are with 16QAM modulation, RBW=30 KHz, Spans=30 MHz to 10 GHz	107
GSM INTERMODS, 1 Carrier (936 MHz) at the bottom and 2 Carriers (958.5 MHz & 959 MHz) at the top. All the Carriers are with 16QAM modulation, RBW=30 KHz, Spans=25 MHz	108
GSM INTERMODS, 1 Carrier (936 MHz) at the bottom and 2 Carriers (958.5 MHz & 959 MHz) at the top. All the Carriers are with 16QAM modulation, RBW=30 KHz, Spans=50 MHz	109

GSM INTERMODS, 1 Carrier (936 MHz) at the bottom and 2 Carriers (958.5 MHz & 959 MHz) at the top. All the Carriers are with 16QAM modulation, RBW=30 KHz, Spans=30 MHz to 10 GHz	110
GSM OUTPUT	111
GSM INPUT	112
F3E INTERMODS, 2 Carriers (1806MHz & 1812MHz) at the bottom of the band and 1 Carrier (1879MHz) at the top. All the Carriers are with FM modulation, DIV=12.5KHz, INT=1KHz, RBW=1 MHz, Spans=100 MHz	113
F3E INTERMODS, 2 Carriers (1806MHz & 1812MHz) at the bottom of the band and 1 Carrier (1879MHz) at the top. All the Carriers are with FM modulation, DIV=12.5KHz, INT=1KHz, RBW=1 MHz, Spans=200 MHz	114
F3E INTERMODS, 2 Carriers (1806MHz & 1812MHz) at the bottom of the band and 1 Carrier (1879MHz) at the top. All the Carriers are with FM modulation, DIV=12.5KHz, INT=1KHz, RBW=1 MHz, Spans=30MHz to 20GHz	115 116
F3E INTERMODS, 1 Carrier (1806MHz) at the bottom and 2 Carriers (1872MHz & 1879MHz) at the top. All the Carriers are with FM modulation, DIV=12.5KHz, INT=1KHz, RBW=1 MHz, Spans=100 MHz	117
F3E INTERMODS, 1 Carrier (1806MHz) at the bottom and 2 Carriers (1872MHz & 1879MHz) at the top. All the Carriers are with FM modulation, DIV=12.5KHz, INT=1KHz, RBW=1 MHz, Spans=200 MHz	118
F3E INTERMODS, 1 Carrier (1806MHz) at the bottom and 2 Carriers (1872MHz & 1879MHz) at the top. All the Carriers are with FM modulation, DIV=12.5KHz, INT=1KHz, RBW=1 MHz, Spans=30MHz to 20GHz	119 120
F3E OUTPUT	121
F3E INPUT	122
GSM INTERMODS, 2 Carriers (1806MHz & 1812MHz) at the bottom of the band and 1 Carrier (1879MHz) at the top. All the Carriers are with GSM modulation, RBW=1 MHz, Spans=100 MHz	123
GSM INTERMODS, 2 Carriers (1806MHz & 1812MHz) at the bottom of the band and 1 Carrier (1879MHz) at the top. All the Carriers are with GSM modulation, RBW=1 MHz, Spans=200 MHz	124
GSM INTERMODS, 2 Carriers (1806MHz & 1812MHz) at the bottom of the band and 1 Carrier (1879MHz) at the top. All the Carriers are with GSM modulation, RBW=1 MHz, Spans=30MHz to 20GHz	125 126
GSM INTERMODS, 1 Carrier (1806MHz) at the bottom and 2 Carriers (1872MHz & 1879MHz) at the top. All the Carriers are with GSM modulation, RBW=1 MHz, Spans=100 MHz	127

GSM INTERMODS, 1 Carrier (1806MHz) at the bottom and 2 Carriers (1872MHz & 1879MHz) at the top. All the Carriers are with GSM modulation, RBW=1 MHz, Spans=200 MHz	128
GSM INTERMODS, 1 Carrier (1806MHz) at the bottom and 2 Carriers (1872MHz & 1879MHz) at the top. All the Carriers are with GSM modulation, RBW=1 MHz, Spans=30MHz to 20GHz	129 130
GSM OUTPUT	131
GSM INPUT	132