

Corning

HX™ Mid-Power DAS System
User Manual

DRAFT

Warranties

Hardware

Corning Optical Communications Wireless, Inc. (“Corning”) warrants to the original purchaser (“Customer”) that for the duration of the warranty period, one (1) year, commencing on the date of shipment of the Hardware, unless otherwise agreed in writing by Corning

(the “Hardware Warranty Period”), the Hardware furnished by Corning shall be free in all material respects from defects in material and workmanship, and shall conform to the applicable portions of the Specifications, as defined below (the “Hardware Warranty”). If notified by Customer of any such defects in material or workmanship or nonconformity with applicable portions of the Specifications within the Hardware Warranty Period, Corning Optical Communications shall promptly, at its own election and expense, repair or replace any such Hardware proven to be defective under the terms of this Hardware Warranty. Such repair or replacement shall be Customer’s sole remedy and Corning Optical Communications’ sole obligation in the event this Hardware Warranty is invoked. If any components comprising a part of the Hardware are replaced or repaired during the Hardware Warranty Period, the Hardware Warranty Period for such repaired or replaced components shall extend to the longer of (i) the balance of the Hardware Warranty Period or (ii) three (3) months from the date of repair or replacement. For purposes of this Warranty, “Specifications” shall mean the specifications and performance standards of the Products as set forth in documents published by Corning Optical Communications and delivered to Customer which contain technical specifications or performance standards for the Products.

If Customer invokes this Hardware Warranty, it shall notify Corning promptly of the claimed defect. Customer will allow Corning to inspect the Hardware at Customer’s location, or to return the Hardware to Corning’s closest repair facility. For Hardware returned to Corning’s repair facility, Customer shall be responsible for payment of all transportation and freight costs (including insurance) to Corning’s repair facility, and Corning shall be responsible for all transportation and freight costs (including insurance) incurred in connection with the shipment of such Hardware to other repair facilities of Corning and/or its return to Customer.

Notwithstanding the foregoing, in no event will Corning be liable for damage to Products resulting from improper handling during or after shipment, misuse, neglect, improper installation, operation or repair (other than by authorized Corning personnel), alteration, accident, or for any other cause not attributable to defects in materials or workmanship on the part of Corning. Corning shall not reimburse or make any allowance to Customer for any labor charges incurred by Customer for replacement or repair of any goods unless such charges are authorized in advance in writing by Corning.

Software Warranty

Corning warrants to the original purchaser (“Customer”) that for the duration of the warranty period, one (1) year, commencing on the date of shipment of the Software, unless otherwise agreed in writing by Corning (the “Software Warranty Period”), the Software shall conform with, and perform the functions set forth in the Specifications, and shall be free from defects in material or workmanship (the “Software Warranty”). In the event the Software is proven to be defective under the terms of this Software Warranty, Corning shall correct such defects or failure and ensure that the Software conforms with, and performs the functions set forth in, the Specifications. Customer will allow Corning to inspect the Software at Customer’s location or to return it to Corning’s closest repair facility.

Notwithstanding the foregoing, Corning shall have no obligation under the Software Warranty if the Software is modified or used with hardware or software not supplied or approved by Corning or if the Software is subject to abuse, improper installation or application, accident, electrical or environmental over-stress, negligence in use, storage, transportation or handling.

Third-party software distributed with the Software may carry certain warranties which, to the maximum extent allowed by law, Corning hereby assigns, transfers and otherwise conveys to Customer, provided, however, that Corning itself provides no warranty of any kind, express, implied, statutory or otherwise, for any third-party software provided hereunder.

Corning does not warrant any hardware, software or services not provided by Corning.

THIS WARRANTY IS THE ONLY WARRANTY MADE BY CORNING AND IS IN LIEU OF ALL OTHER WARRANTIES, EXPRESS OR IMPLIED INCLUDING, BUT NOT LIMITED TO, THE IMPLIED WARRANTIES OF MERCHANTABILITY AND FITNESS FOR A PARTICULAR PURPOSE. CORNING SHALL NOT BE LIABLE FOR ANY OTHER DAMAGE INCLUDING, BUT NOT LIMITED TO, INDIRECT, SPECIAL OR CONSEQUENTIAL DAMAGES ARISING OUT OF OR IN CONNECTION WITH FURNISHING OF GOODS, PARTS AND SERVICE HEREUNDER, OR THE PERFORMANCE, USE OF, OR INABILITY TO USE THE GOODS, PARTS AND SERVICE. CORNING SALES AGENTS OR REPRESENTATIVES ARE NOT AUTHORIZED TO MAKE COMMITMENTS ON WARRANTY RETURNS.

Returns

In the event that it is necessary to return any product against above warranty, the following procedure shall be followed:

1. Return authorization is to be received from Corning prior to returning any unit. Advise Corning of the model, Serial number, and discrepancy. The unit may then be forwarded to Corning Optical Communications, transportation prepaid. Devices returned collect or without authorization may not be accepted.
2. Prior to repair, Corning will advise the customer of our test results and any charges for repairing customer-caused problems or out-of-warranty conditions etc.
3. Repaired products are warranted for the balance of the original warranty period, or at least 90 days from date of shipment.

Limitations of Liabilities

Corning's liability on any claim, of any kind, including negligence for any loss or damage arising from, connected with, or resulting from the purchase order, contract, quotation, or from the performance or breach thereof, or from the design, manufacture, sale, delivery, installation, inspection, operation or use of any equipment covered by or furnished under this contact, shall in no case exceed the purchase price of the device which gives rise to the claim.

Except as expressly provided herein, Corning makes no warranty, expressed or implied, with respect to any goods, parts and services provided in connection with this agreement including, but not limited to, the implied warranties of merchantability and fitness for a particular purpose. Corning shall not be liable for any other damage including, but not limited to, indirect, special or consequential damages arising out of or in connection with furnishing of goods, parts and service hereunder, or the performance, use of, or inability to use the goods, parts and service.

Reporting Defects

The units were inspected before shipment and found to be free of mechanical and electrical defects. Examine the units for any damage that may have been caused in transit. If damage is discovered, file a claim with the freight carrier immediately. Notify Corning as soon as possible in writing.

Note: Keep all packing material until you have completed the inspection.

Warnings and Admonishments

There may be situations, particularly for workplace environments near high-powered RF sources, where recommended limits for safe exposure of human beings to RF energy could be exceeded. In such cases, restrictive measures or actions may be necessary to ensure the safe use of RF energy.

The equipment has been designed and constructed to prevent, as far as reasonably, practicable danger. Any work activity on or near equipment involving installation, operation or maintenance must be, as far as reasonably, free from danger.

Where there is a risk of damage to electrical systems involving adverse weather, extreme temperatures, wet, corrosive or dirty conditions, flammable or explosive atmospheres, the system must be suitably installed to prevent danger.

Equipment provided for the purpose of protecting individuals from electrical risk must be suitable for the purpose and properly maintained and used. This covers a range of activities including lifting, lowering, pushing, pulling, carrying, moving, holding or restraining an object, animal or person from the equipment. It also covers activities that require the use of force or effort, such as pulling a lever, or operating power tools.

Where some of the abovementioned activities are required, the equipment must be handled with care to avoid being damaged.

Observe standard precautions for handling ESD-sensitive devices. Assume that all solid-state electronic devices are ESD-sensitive. Ensure the use of a grounded wrist strap or equivalent while working with ESD-sensitive devices. Transport, store, and handle ESD-sensitive devices in static-safe environments.

RF Safety

WARNING! To comply with FCC RF exposure compliance requirements, each individual antenna used for this transmitter must be installed to provide a separation distance greater than 170 cm or more from all persons during normal operation and must not be co-located with any other antenna for meeting RF exposure requirements.

The design of the antenna installation needs to be implemented in such a way so as to ensure RF radiation safety levels and non-environmental pollution during operation.

WARNING! Antenna gain should not exceed 12.5 dBi.

WARNING! The design of the antenna installation needs to be implemented in such a way so as to ensure RF radiation safety levels and non-environmental pollution during operation.

Compliance with RF safety requirements:

- Corning products have no inherent significant RF radiation.
- The RF level on the downlink is very low at the downlink ports. Therefore, there is no dangerous RF radiation when the antenna is not connected.

Power requirements for DC Inputs

WARNING! Only use a special DC supply cable with four connectors

WARNING! Always keep DC IN connectors connected during the product operation

WARNING! Disconnect all power from the equipment by means of an external circuit breaker before connecting or disconnecting the DC IN connectors.

Laser Safety

Fiber optic ports of the HX system emit invisible laser radiation at the 1310/1550 nm wavelength window.

The laser apertures /outputs are the green SC/APC Bulkhead adapters located on the front panel of the equipment.

The product is Class 1/Hazard level 1

External optical power is less than 10 mW, Internal optical power is less than 500 mW.

To avoid eye injury never look directly into the optical ports, patchcords or optical cables. Do not stare into beam or view directly with optical instruments. Always assume that optical outputs are on.

Only technicians familiar with fiber optic safety practices and procedures should perform optical fiber connections and disconnections of HX devices and the associated cables.

HX has been tested and certified as a Class 1 Laser product to IEC/EN 60825-1 (2007). It also meets the requirements for a Hazard Level 1 laser product to IEC/EN 60825-2: 2004 to the same degree.

HX complies with 21 CFR 1040.10 and 1040.11 except for deviations pursuant to Laser Notice NO. 50 (2007).

Care of Fiber Optic Connectors

Do not remove the protective covers on the fiber optic connectors until a connection is ready to be made. Do not leave connectors uncovered when not connected.

The tip of the fiber optic connector should not come into contact with any object or dust.

Regulatory Compliance Information



WARNINGS!

- This is **NOT** a **CONSUMER** device. It is designed for installation by **FCC LICENCEES** and **QUALIFIED INSTALLERS**. You **MUST** have an **FCC LICENSE** or express consent of an FCC Licensee to operate this device. Unauthorized use may result in significant forfeiture penalties, including penalties in excess of \$100,000 for each continuing violation.
- **ANTENNAS:** Use only authorized and approved antennas, cables and/or coupling devices! The use of unapproved antennas, cables or coupling devices could cause damage and may be of violation of FCC regulations. The use of unapproved antennas, cables and/or coupling devices is illegal under FCC regulations and may subject the user to fines.

Standards and Certifications

Corning Optical Communications products have met the approvals of the following certifying organizations:

Company Certification

ISO 9001: 2000 and ISO 13485: 2003

Product Certification

US Radio Equipment and Systems

- FCC 47 CFR part 22 – for CELL Frequency Band
- FCC 47 CFR part 24 – for PCS Frequency Band
- FCC 47 CFR part 27 – for LTE and AWS Frequency Bands

EMC

- FCC CFR part 15 Subpart B

Note: This equipment has been tested and found to comply with the limits for a Class A digital device, pursuant to Part 15 of the FCC Rules. These limits are designed to provide reasonable protection against harmful interference in a residential installation. This equipment generates, uses and can radiate radio frequency energy and, if not installed and used in accordance with the instructions, may cause harmful interference to radio or television reception, which can be determined by turning the equipment off and on, the user is encouraged to try to correct the interference by one or more of the following measures:

- Reorient or relocate the receiving antenna.
- Increase the separation between the equipment and receiver.
- Connect the equipment into an outlet on a circuit different from that to which the receiver is connected.
- Consult the dealer or an experienced radio/TV technician for help.

Warning!

Changes or modifications to this equipment not expressly approved by Corning Mobile Access could void the user's authority to operate the equipment.

Europe Radio Equipment and Systems

- EN 301502 – for GSM/EGSM Frequency Bands
- EN 300609 – for DCS Frequency Bands
- EN 301908 – for UMTS Frequency Band

EMC

- EN 301 489

Licensee Contact Information

Industrial Boosters may only be used by FCC licensees or those given express (individualized) consent of license. Corning certifies all of the VARs listed as licensed installers for Corning. For the list of licensed VARs, please contact the Corning Tech Support Hotline: (US) 410-553-2086 or 800-787-1266.

About this Guide

This Installation Guide describes how to perform the physical installation of the HX Indoor and Outdoor units (not including HX2600). The installation procedures of other units (e.g. RIU, OCH-HX, SC-450) relevant to the system are detailed in their user manuals (see Additional Relevant Documentation).

Additional Relevant Documents

The following documents are required if the corresponding units are included in your system.

Document Name
RIU Product Line User Manual; RIU-12 User Manual
FT350 User Manual (includes OCH information)
System Controller (SC-450) User Manual
MA Software Version Update Tool

List of Acronyms

Acronym	Description
BDA	Bi-Directional Amplifier
BTS	Base Transceiver Station
BU	Base Unit
DL	Downlink
HX	High Power Transmission
OCH-HX	Optical Central Hub (HX model)
RU	Remote Unit
RIU	Radio Interface Unit
SC-450	System Controller
UL	Uplink

Table of Contents

Warranties	2
Hardware.....	2
Software Warranty	2
Returns.....	3
Limitations of Liabilities	3
Reporting Defects	3
Warnings and Admonishments	4
RF Safety	4
Compliance with RF safety requirements:	4
Power requirements for DC Inputs	4
Laser Safety	5
Care of Fiber Optic Connectors	5
Regulatory Compliance Information	5
Standards and Certifications	6
Company Certification.....	6
Product Certification.....	6
Licensee Contact Information	6
About this Guide	7
Additional Relevant Documents.....	7
List of Acronyms	7
Table of Contents	8
1 Introduction	11
1.1 System Architecture	13
1.1.1 HX Neutral Host Solution	15
1.2 Application Topologies	16
1.3 System Monitoring and Management	17
1.4 HX Unit Interfaces	18
1.4.1 HX Indoor Interfaces	18
1.4.1.1 HX Indoor SISO Internal and Front Panel Interfaces	18
1.4.1.2 HX Indoor MIMO Internal and Front Interfaces	20
1.4.2 HX Outdoor Unit Interfaces.....	22

2	Installation Guidelines	23
2.1	Site Considerations	23
2.2	Environmental	23
2.3	Installation Requirements	23
2.4	Fiber Optic Requirements	24
2.4.1	Authorized Optic Cables	24
2.4.2	Fiber Optic Rules	25
2.5	RF Coaxial Cable Guidelines	25
2.5.1	General Cable Installation Procedures	25
2.5.2	RF Rules	26
2.5.3	Coax Cable Lengths and Losses	26
2.5.4	Cable Routing	27
2.6	Antenna Specifications and Guidelines	27
2.6.1	Authorized Antennas and Couplers	27
2.6.2	General Antenna Installation Guidelines	27
2.7	Grounding Requirement	27
2.8	Manual Handling	27
3	HX Indoor Physical Installation	28
3.1	Unpacking and Inspection	28
3.2	Mounting	29
3.2.1	General Instructions	29
3.2.2	Rack Mount Installation	29
3.2.3	Wall-Mount Installation	31
3.2.3.1	Required/Recommended Tools and Materials for Wall Mount Installation	31
3.2.3.2	Mounting HX on Wall	31
3.3	Connections	34
3.3.1	RF and Fiber Connections	34
3.3.2	Ground Connection	35
3.3.3	Power Connections	35
3.3.3.1	AC Models	35
3.3.3.2	DC Models	36
3.3.4	Routing Fiber and Power Cables	37
3.4	Verify Normal Operation	38
4	HX Outdoor Physical Installation	39
4.1	General Information	39
4.2	Unpacking and Inspection	39
4.3	HX Outdoor Dimensions	40
4.4	Required/Recommended Tools and Materials for Wall Mount Installation	41
4.5	Mounting	42
4.5.1	Wall Mount Installation	42
4.5.2	Pole Mount Installation	45
4.5.3	Connections	48
4.5.4	RF and Fiber Connections	48
4.5.5	Ground Connection	49
4.5.6	Power Connections	50

4.5.6.1 AC Power Input Model Connections.....	50
4.5.6.2 DC Power Input Model Connections.....	51
4.6 Verify Normal Operation.....	52
Appendix A: System Specifications	53
RF Parameters.....	53
Supported Services	53
RF Parameters per Low-Band Service	53
RF Parameters per High-Band Service.....	54
Coupling Specifications*	54
Optical Specifications	55
Physical Specifications.....	55
Indoor Remote Unit.....	55
Outdoor Remote Unit	56
Environmental Specifications	56
Standards and Certifications	56
Appendix B: Ordering Information	57
HX Indoor Remote Units (SISO and MIMO)	57
HX Remote Outdoor Units (SISO services).....	58
Accessory Kits.....	59
Optical Central Hub (OCH) - HX International products	59
Corning OptiTap™ Cables.....	59
Appendix C: HX Outdoor Non-Standard Connector Descriptions.....	60
Appendix D: Power Cable Specifications.....	61
AC Power Cable Specifications	61
DC Power Cable Specifications.....	61

1 Introduction

HX is a mid-power, remote solution for the MA1000 and MA2000 Distributed Antenna Systems (DAS). It is a fiber fed, compact and scalable multi-service platform designed to complement the MA1000 and MA2000 while providing complete RF open space coverage for large-scale public venues such as campuses, stadiums, convention centers, hotels, airports and train stations. The solution can be deployed in new sites or alongside existing lower power MA1000 and MA2000 systems, sharing a common headend and element management system (SC-450).

HX supports multiple wireless technologies and operator services over a single broadband infrastructure. Using low-loss fiber optic cabling, remote units can cover distances of up to 2 km from the BTS signal sources at the headend.

Alongside MA1000 and MA2000 deployments, HX provides a comprehensive indoor and outdoor coverage solution for varying site requirements, supporting everything from high-rise buildings and campus topologies to stadiums and airports.

In addition, the HX remote can be combined with an MA2000 lower power remote or HX remote supporting the HX 800 MHz ESMR band to create an HX Neutral Host Solution. The NH solution addresses the need for complete multiservice coverage while meeting RSSI requirements for different cellular technologies.

Note: Refer to the HX Neutral Host Solution Application Note for details on combining HX Quad-Band solution with Sprint's 800 MHz Band (CMA-238-AEN).



HX Indoor Model (LT) and HX Outdoor Model (RT) | Figure 1-1

Features and Capabilities

- **Multi-Service Platform:** Accommodates GSM, UMTS, HSPA, LTE, EDGE, EV-DO, AWS, and more. Provides MIMO configuration for LTE700, AWS, and UMTS band.
- **Cost-Effective High Power:** Optimizes and reduces the number of antennas required to cover open areas by offering up to 33dBm (2W) composite power per frequency band.
- **Indoor Models:** Support either SISO or MIMO (excluding HX-5 units) service in a single compact enclosure.
- **Outdoor Models:** Outdoor enclosures are compliant to NEBS OSP Class 4 standards.
- **Operator-Grade Operation:** Advanced signal handling and management ensures carrier-grade performance in multi-operator deployments.
- **Design and Deployment Flexibility:** Remote unit supports both SM and MM fiber connections, and are available in AC or DC power supply options. Antenna splitting schemes are possible due to the higher power output capability.
- **Backwards Compatible:** Connects to an existing MA1000/MA2000 deployment and shares a common headend and Element Management System (EMS) in a single deployment.

1.1 System Architecture

HX mid-power remote unit compliments the MA1000 or MA2000 system, providing a complete solution consisting of HX remote units at the remote locations and headend elements that are shared with any other MA1000 or MA2000 system remotes that are either installed or being installed at the site.

In the downlink, at the headend, the BTS or BDA signal is conditioned by the RIU, ensuring a constant RF level. The conditioned signal is then converted by an optical converter unit (i.e. Base Unit (BU)/Optical Central Hub (OCH) to an optical signal to transport over single-mode or multimode fiber to the HX remote units, which are located at the remote locations. In the uplink, the process is reversed.

The System Controller (SC-450) enables local and remote management, as well as controls all MA1000, MA2000 and HX elements from a single, centralized location.

The HX Remote Unit (indoor-SISO/MIMO and outdoor-SISO models) consists of a compact enclosure that houses the RF module, power elements and the required interfaces. The RF module supports various configurations of three (International models), four and five bands.

Note: HX-5 units are SISO only.

All mobile services are combined and distributed through a single antenna port over antennas installed at the remote locations.

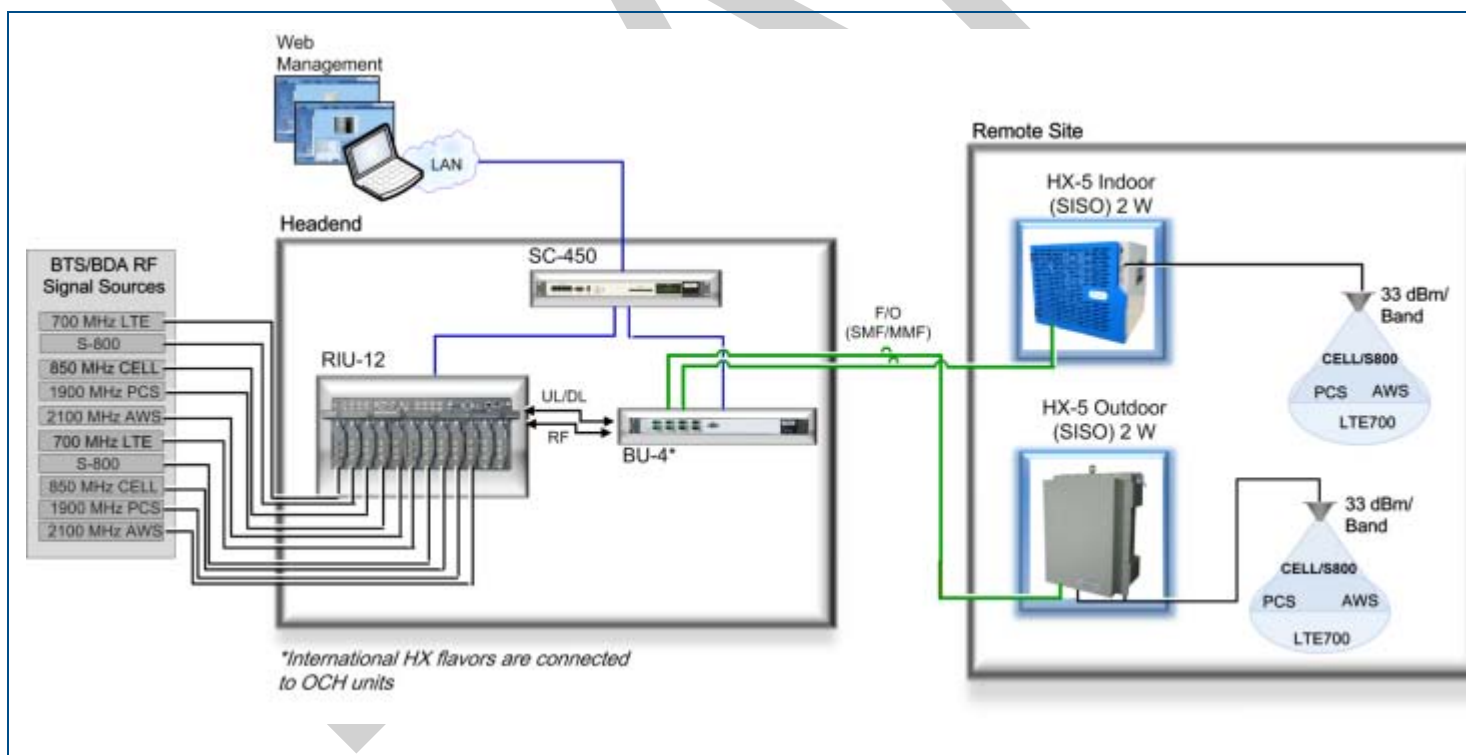

Example of Indoor/ Outdoor SISO Architecture with HX-5

Figure 1-2

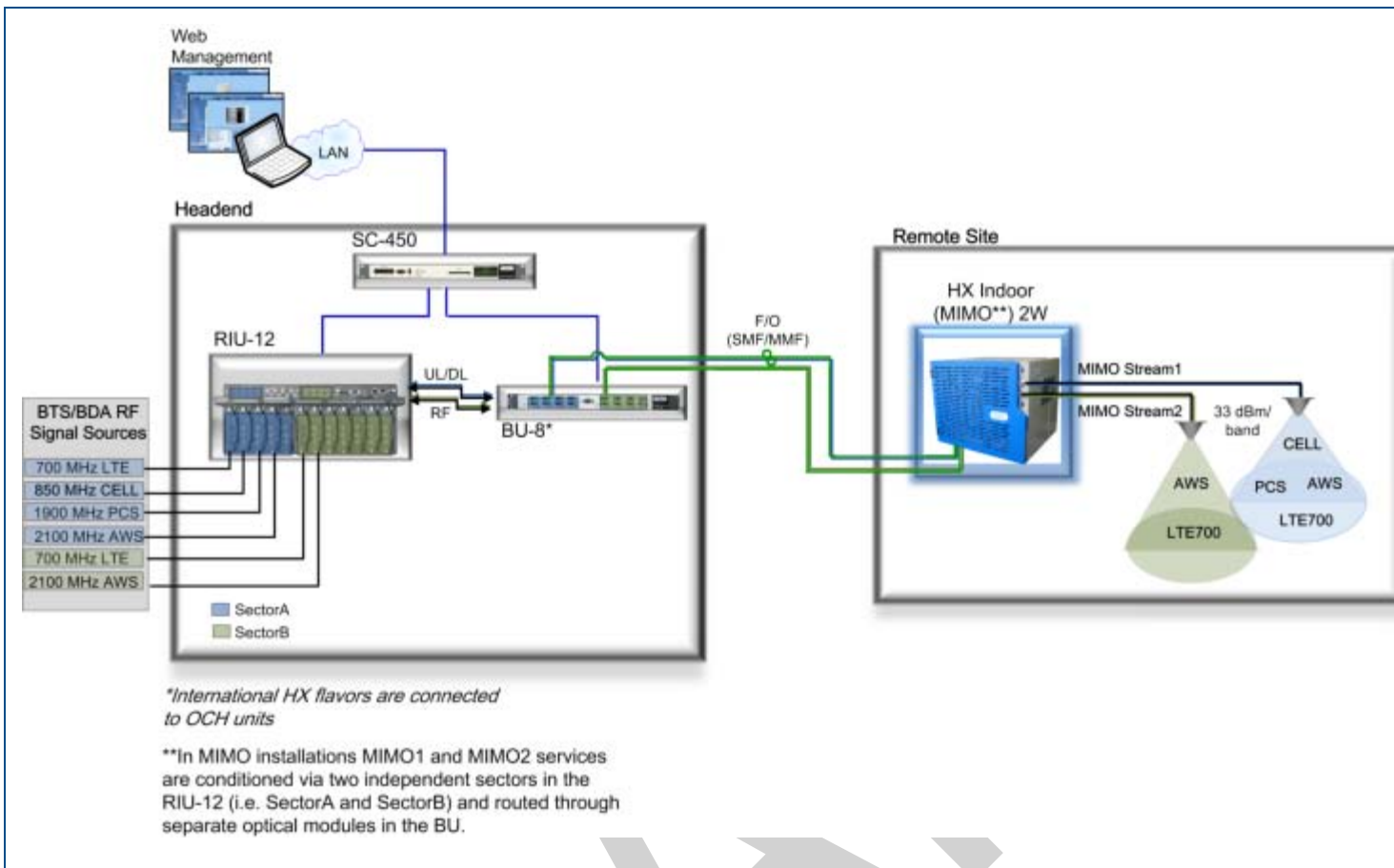

Example of Indoor MIMO Architecture with HX Quad-Band

Figure 1-3

1.1.1 HX Neutral Host Solution

Corning HX Neutral Host addresses the need for a high-output multi-operator distributed antenna solution (DAS) that provides complete multiservice coverage and meets RSSI requirements for different cellular technologies. The HX Neutral Host solution provides a complete suite of solutions to combine 850 CELL, 1900 PCS, 700 LTE and 2100 AWS services of the HX product with 800 MHz ESMR band.

HX Neutral Host extends the multiband support of the HX to 800 MHz ESMR band by providing solutions to combine the corresponding Corning MA2K system, supporting the 800 MHz ESMR band or HX supporting the 800 MHz ESMR band to create the HX NH solution.

Note: The 800 MHz ESMR band is a low frequency band so that it also meets the RSSI requirements despite lower output power.

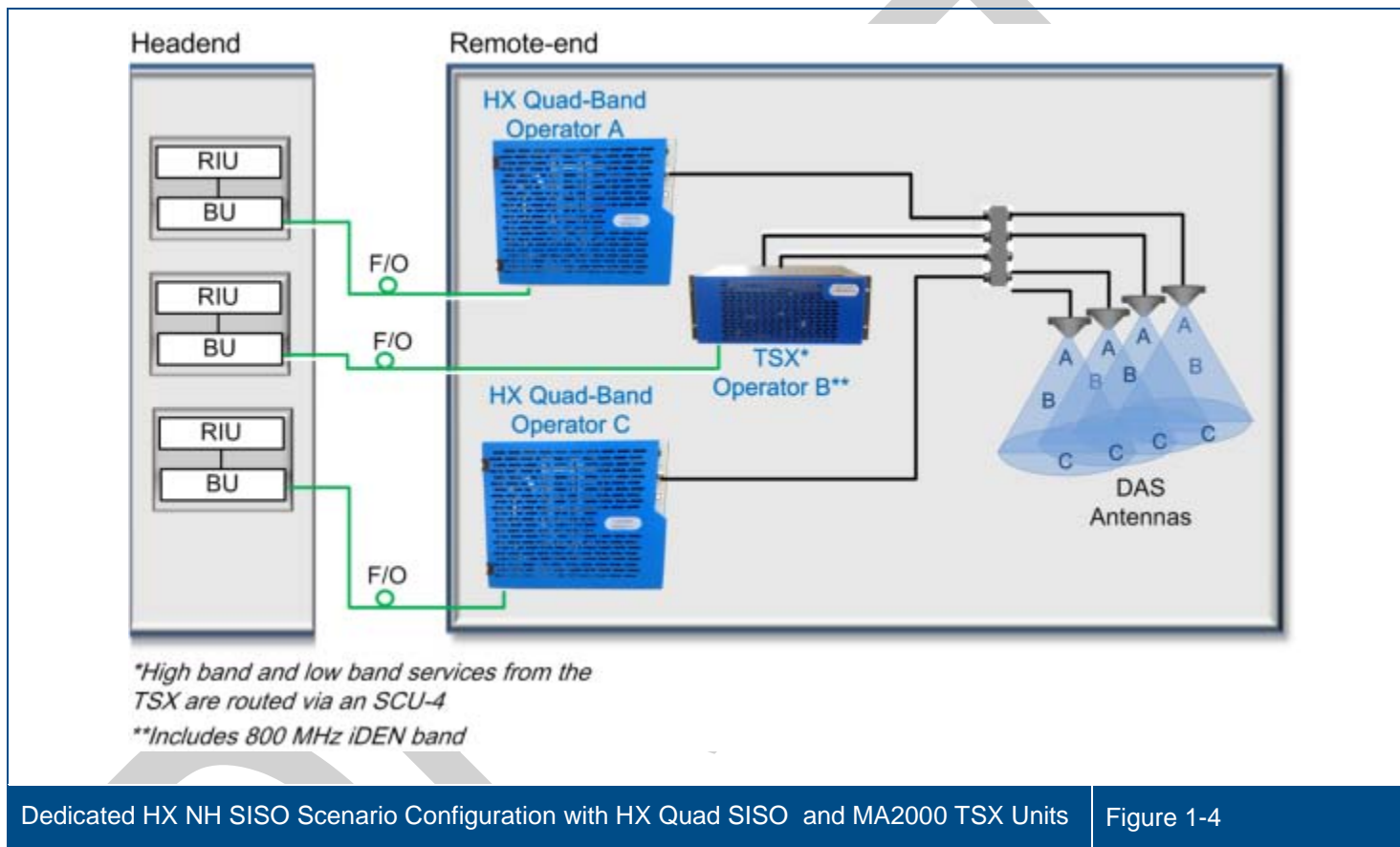

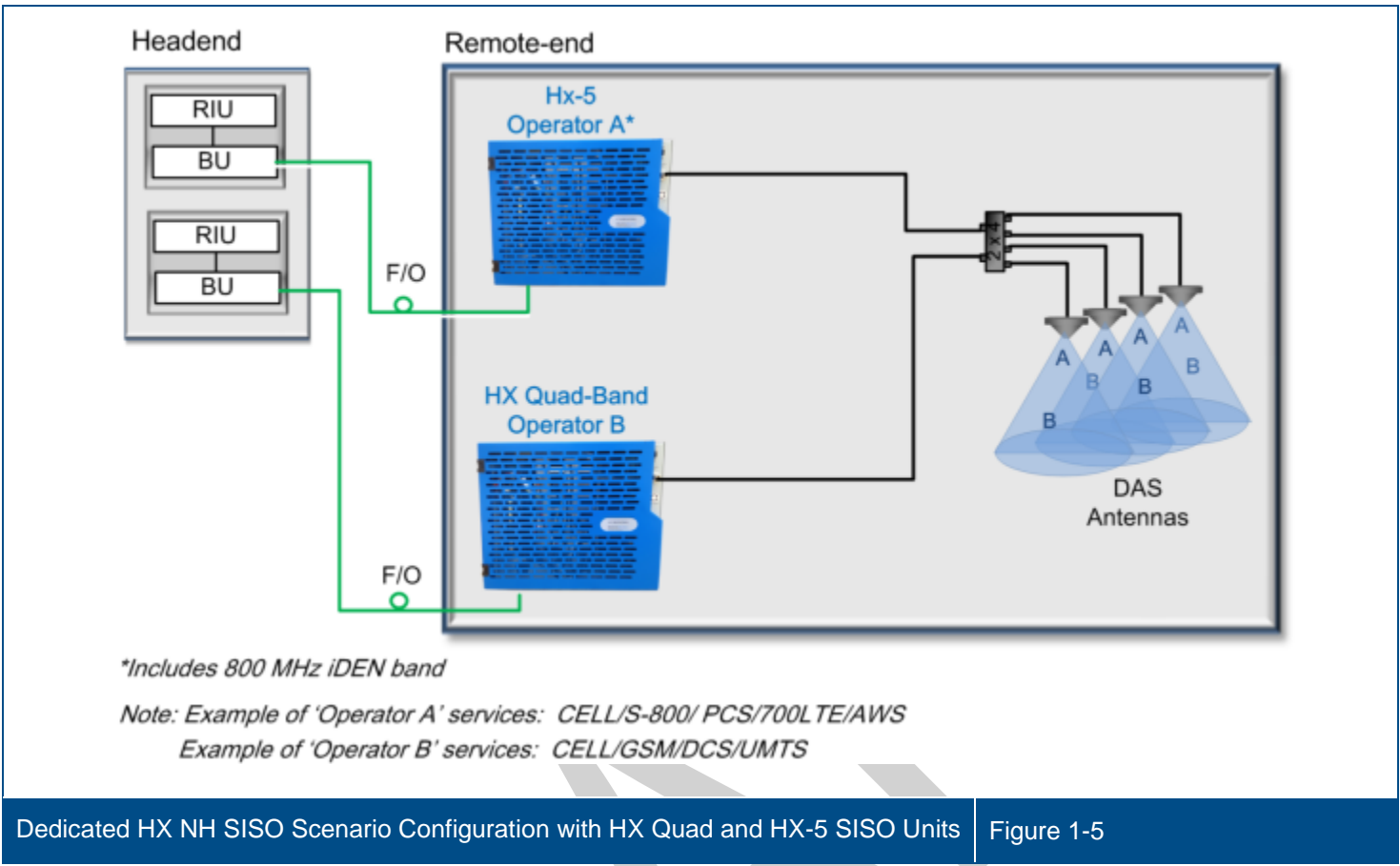

1.2 Application Topologies

HX can be installed in various site topologies. The setup procedure varies accordingly:

- High-power coverage via a single antenna - used for open area, stadium, parking lots, etc.
- RF signal is distributed over several antennas via splitters
- Special coverage requirements using directional antennas

1.3 System Monitoring and Management

The HX Remote Unit is centrally managed via the SC-450 Controller. Note that HX is not connected directly to the controller. It is connected to the optical converter (i.e. BU or OCH-HX), connected to the controller. Thus, the controller monitors views and manages the HX via the optical converter module to which the HX is connected.

The following shows the Config(uration) tabs of the selected HX unit. Refer to the SC-450 Controller User Manual for information on how to configure and manage the HX (Indoor/Outdoor) unit.

The screenshot displays the CORNING SC-450 Controller web interface. The top navigation bar includes 'Monitor', 'Config', 'Events', 'Setup', 'Management', and 'Help'. The left sidebar shows a tree view of the system hierarchy, including the SC-450 Controller, Host BU Module, and HX Indoor Unit. The main content area shows the configuration page for a selected HX unit, with tabs for 'Info', 'RF Parameters', 'DL Adjustment', 'Service Alarms', and 'Customize'. The 'Service Alarms' tab is active, showing a list of alarm types with checkboxes for enabling or disabling them. The 'Info' tab shows details for the 'Outdoor USA' unit, including model, serial number, and link status.

Example of HX Configuration Tab

Figure 1-6

1.4 HX Unit Interfaces

The HX antenna port (two for MIMO) is located externally. All other interfaces such as F/O connections, power connections, etc. are located inside the cabinet and are accessed by opening the cabinet door.

1.4.1 HX Indoor Interfaces

1.4.1.1 HX Indoor SISO Internal and Front Panel Interfaces

The HX Indoor ANTENNA port (two for MIMO models) is located externally. All other interfaces such as F/O connections, power connections, etc. are located inside the cabinet and are accessed by opening the cabinet door.

The HX Model Components:

- **Quad-band Service Module** – Connects to the optical converter unit (BU/OCH) using a single fiber pair and supports up to four services
- **External Amplifier Blade** – Two External Amplifiers are mounted on each of the two blades and provide the additional amplification on the DL signals coming from the Quad-band Service Module to the Multiplexer
- **8:1 Multiplexer** – Combines UL and DL signals of the four bands, while providing the proper filtering, into a single duplexed antenna port
- **Power Supply** – Local AC or Remote DC power feed (model dependent)
- **Duplexed Antenna Port** * – Interface to RF antennas
- ****Coupler Ports** – Coupler ports used for enabling the user/field engineer to measure the signals at the remote without disconnecting the antenna cable and affecting services on the main stream.

* Upgradeable SISO models include MIMO1 and MIMO2 duplex RF ports and craft ports, however only the MIMO1 ports are applicable.

** Model dependant – refer to Ordering Information in Appendix B.

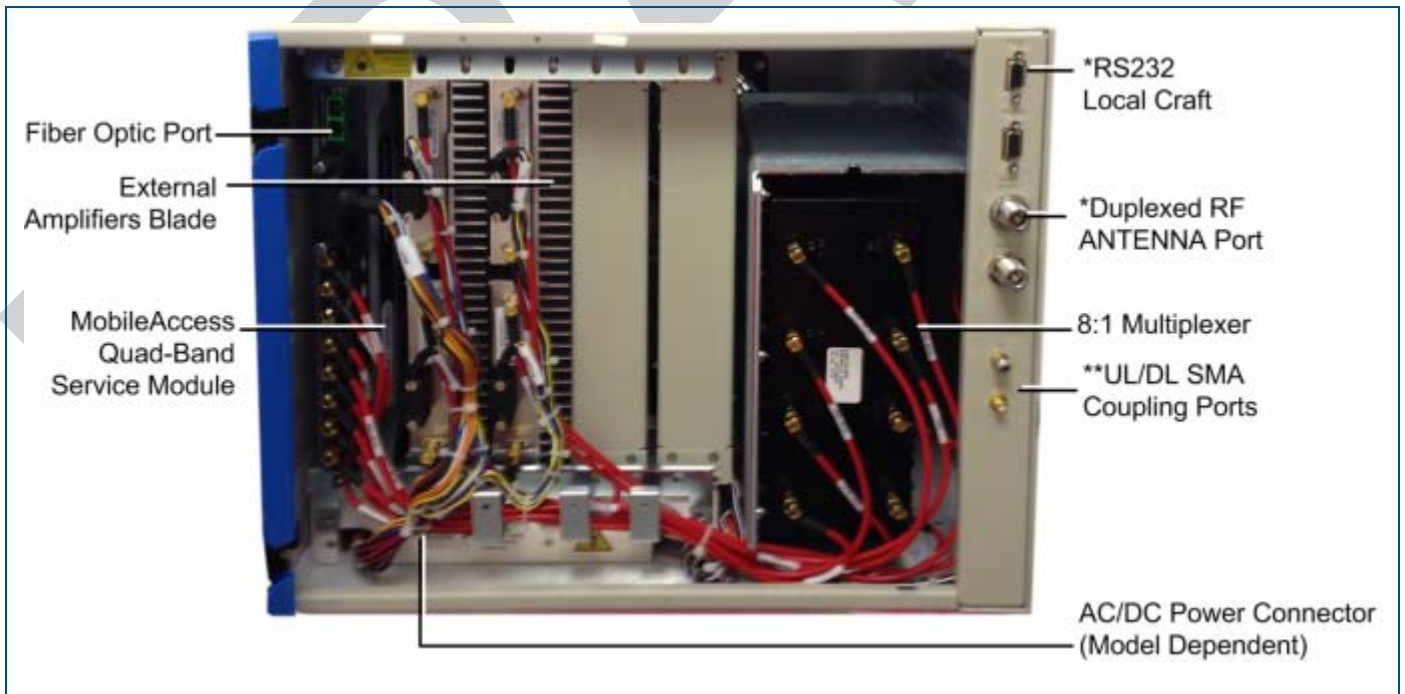

Example of Indoor HX Remote Unit Interfaces – Front View

Figure 1-7

Table 1-1 and Table 1-2 provide descriptions of the HX Indoor connectors and LEDs.

Connector	Description
F/O	SC/APC fiber-optic connector for either SM or MM fibers
Antenna	N-Type female 50Ω duplexed connector for RF antenna
AC PWR	100/240 VAC; 50/60 Hz; 8A Slow Blow Fuse
DC	18 pin power connector for 25-48V DC power feeds
RS-232	Local craft connector

Table 1-1. Connector Descriptions

LED	Description	Color	Status
Power	Device is powered	Green	Steady On
	Power not supplied to the unit	Green	Off
Comm	When connected and discovered by an OPTM (BU)	Green	Blink per communication attempt
	When device is powered on but no external communication is received	Green	Steady Slow Blink
Link	No Optical link is present	Green	Off
	Low optical link level from OPTM	Green	Blink
	Normal optical link level from OPTM	Green	Steady On

Table 1-2. LED Descriptions

The HX Indoor rear panel includes the grounding lug and ventilation fans.

Note: The rear interfaces are the same for both HX Indoor SISO and MIMO cabinets.



Indoor HX Remote Unit - Rear View | Figure 1-8

1.4.1.2 HX Indoor MIMO Internal and Front Interfaces

Note: HX-5 units include SISO models only.

The two HX Indoor antenna ports are located externally. All other interfaces such as F/O connections, power connections, etc. are located inside the cabinet and are accessed by opening the cabinet door.

The HX Indoor MIMO model includes the following main components:

- **RF Modules:**
 - Quad-band Service Module – connects to the Base Unit using a single fiber pair and supports up to four services (SISO/MIMO1)
 - Additional RF module providing support for two MIMO2 services – connects to the Base Unit using a single fiber pair
- **External Amplifier Blade** – Two External Amplifiers are mounted on each of the 2 blades and provide the additional amplification on the DL signals coming from the Quad-band Service Module top the Multiplexer
- **8:1 Multiplexer** – combines UL and DL signals of the four bands, while providing the proper filtering, into a duplexed antenna port
- **Duplexer** - combines UL and DL signals of the Stream 2 MIMO bands , while providing the proper filtering, into the MIMO2 duplexed antenna port
- **Power supply** – local AC or Remote DC power feed (model dependent)
- **Duplexed Antenna Ports** (MIMO1 and MIMO2) – interface to RF antennas

Note: Detailed descriptions of the components and LEDs are provided Table 1-3 and Table 1-4.



Example of HX Indoor MIMO Remote Unit Internal View (Front)

Figure 1-9

Table 1-3 and Table 1-4 provide descriptions of the HX indoor type connectors and LEDs.

Connector	Description
F/O	SC/APC fiber-optic connector for either SM or MM fibers (1 for each RF service module)
Antenna	N-Type female 50Ω duplexed connector for RF antenna (MIMO1 and MIMO2)
AC PWR	100/240 VAC; 50/60 Hz; 8A Slow Blow Fuse
DC PWR	18 pin power connector for 25-48V DC power feeds
RS-232	Local craft connector

Table 1-3. Connector Descriptions

Name	Description	Color	Status
Power	Device is powered	Green	Steady On
	Power not supplied to the unit	Green	Off
Comm	When connected and discovered by an OPTM (BU)	Green	Blink per communication attempt
	When device is powered on but no external communication is received	Green	Steady Slow Blink
Link	No Optical link is present	Green	Off
	Low optical link level from OPTM	Green	Blink
	Normal optical link level from OPTM	Green	Steady On

Table 1-4. LED Descriptions

Note: LEDs are the same for each RF module.

1.4.2 HX Outdoor Unit Interfaces

The HX Outdoor interfaces are located on the underside panel of the unit (connectors face down when unit is mounted). The unit interfaces include the RF, power and optical link connectors.

The power, RS232 and F/O connectors are special weather resistant connectors. You may either order ready cables from Corning or refer to the manufacturer Part Numbers for generating the required cables (Appendix C).

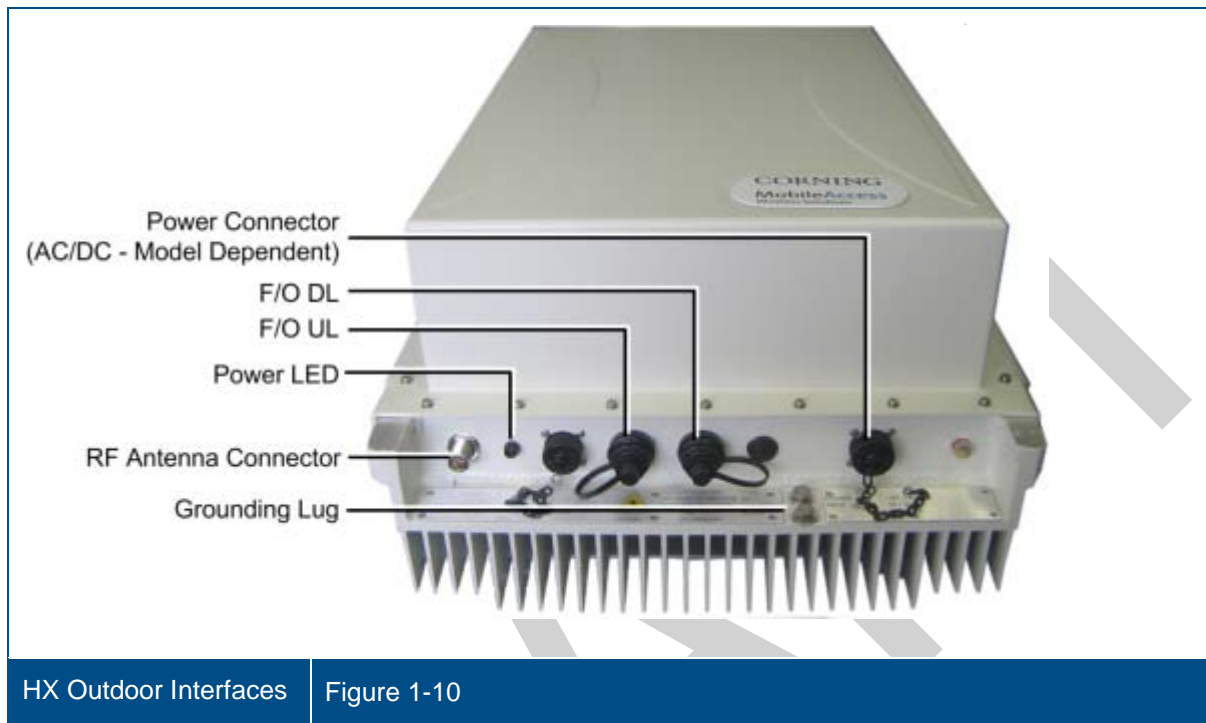

HX Outdoor Interfaces Figure 1-10

Table 1-5 and Table 1-6 provide a description of the HX Outdoor type connectors and LEDs.

Connector	Description
Antenna	N-Type female 50Ω duplexed connector for RF antenna
F/O Uplink and Downlink	Corning OptiTap® fiber-optic waterproof connectors for either SM or MM fibers IMPORTANT! OptiTap™ pullout force ranges from a few lbs to 50+ lbs with the dust cap or connector installed. This prevents damages caused to the DAS unit.
AC or DC PWR (model dependent)	Local Power (AC): -20UNEf, plug, 3-pin waterproof, solder for panel, power connector for 100/240 VAC power feed Remote DC Power: 1-20UNEf, plug, 8-pin waterproof, solder for panel, power connector for 25-48 VDC power feed Max Power Consumption: 340 W
RS-232	One 10-pin RS232 waterproof connector for local craft
Grounding Lug	Two hole, standard barrel grounding lug (LCD10-14A-L Panduit)

Table 1-5. HX Outdoor Connector Descriptions

LED	Description	Color	Status
Power	Device is powered	Green	Steady On
	Power not supplied to the unit	Green	Off

Table 1-6: HX Outdoor PWR LED Description

2 Installation Guidelines

This chapter describes the installation procedure for the HX Indoor (SISO/MIMO) and Outdoor Remote Units. The installation procedure differs according to the type of enclosure.

2.1 Site Considerations

- The distance between the HX service antenna and the coverage area should correspond to LOS (Line of Sight) requirements for maximum coverage area.
- The maximum fiber path loss is 6 dB.
- The system delay of the optical system must be taken into consideration when there are neighboring BTS sites overlapping in coverage.

2.2 Environmental

Humidity has an adverse effect on the reliability of the equipment. It is recommended to install the equipment in locations having stable temperature and unrestricted air-flow.

The installation location for the system should be well ventilated. The equipment has been designed to operate at the temperature range and humidity level as stated in the product specifications with a relative humidity of max. 90% (Indoor models) and temperatures ranging as follows:

Indoor Models: 0 to 50°C (-4° to 185°F)

Outdoor Models: -30° to +65°C (-22° to 149°F)

2.3 Installation Requirements

- Mounting surface shall be capable of supporting the weight of the equipment.
- In order to avoid electromagnetic interference, a proper mounting location must be selected to minimize interference from electromagnetic sources such as large electrical equipment.
- Working space available for installation and maintenance for each mounting arrangement. Ensure unrestricted airflow.
- Ensure grounding connector is within reach of the ground wire.
- Ensure a power source is within reach of the power cord and the power source has sufficient capacity.
- Where appropriate, ensure unused RF connectors are terminated.
- Do not locate the equipment near large transformers or motors that may cause electromagnetic interference.
- Reduce signal loss in feeder cable by minimizing the length and number of RF connections.
- Ensure the equipment will be operated within the stated environment (refer to datasheet).
- Where appropriate, confirm available of suitably terminated grade of RF and optical fiber.
- Observe handling of all cables to prevent damage.

2.4 Fiber Optic Requirements

2.4.1 Authorized Optic Cables

- Either single mode or multimode fiber can be used with HX Indoor/Outdoor products,
- Only Multimode fiber, 50/125 or 62.5/125um complying with ANSI/TIA/EIA-568-B series, EN50173-1 or ISO/IEC 11801 can be used. Fiber optic losses between the HX and the headend will comply to the product specifications.
- All fiber in a given length of fiber must be of the same core diameter.

For HX Indoor models:

All Bulkhead adapters must be either Single mode or Multi mode SC APC (Green) adapters.

- All terminations, cross connections or patches must be direct fusion splice or Corning specified patch cords listed below.

900 microns patchcord for splicing, 2 Meters, 2xSC/APC		
Diamond p/n ENC/1045341	Beige boots, 62.5/125/900	MA# 500001057
Diamond p/n ENC/1045340	Black boots, 50/125/900	MA# 500001058

Zipcord patchcord, 4xSC/APC, 50/125/900/2000/4500 micron		
Diamond p/n ENC/1045342	Black/Brown boots, 1 Meter	MA# 50000105
Diamond p/n ENC/1045343	Black/Brown boots, 3 Meter	MA# 500001060

Zipcord patchcord, 4xSC/APC, 62.5/125/900/2000/4500 micron		
Diamond p/n ENC/1045344	Beige/Brown boots, 1 Meter	MA# 500001061
Diamond p/n ENC/1045345	Beige/Brown boots, 3 Meter	MA# 500001062

For HX Outdoor models :

Use Corning OptiTap™ cables:

Part Number	Description
434401EB4R2005M-P	OptiTap® to SC/APC 5 meters
434401EB4R2030M-P	OptiTap ®to SC/APC 30 meters
434401EB4R2100M-P	OptiTap® to SC/APC 100 meters

2.4.2 Fiber Optic Rules

ATTENTION!

Please also refer to the Laser Safety section in the document Preface.

- Fiber optic cables require proper handling. Do not stretch, puncture, or crush the fiber cable(s) with staples, heavy equipment, doors, etc.
- Always maintain the minimum bending radius specified by the cable manufacturer. The minimum bend radius is usually 10 times the cable's outer diameter. In the case of single optical fiber that is not in a cable, the minimum bending radius to be observed is 30 mm.
- WDM, Wave Division Multiplexing, units require SMF
- For HX Indoor models - use SC APC connectors (green color) 8 deg only.
- For HX Outdoor models – use OptiTap® connector
- Pay special attention while connecting the SC APC connectors - ensure that you hear a “click”, indicating a secure connection
- Use minimum splicing/connectors to achieve minimum losses on the fibers.
- Use precaution while installing, bending, or connecting fiber optic cables.
- Use an optical power meter and OTDR for checking the fiber optic cables.
- Make sure the environment is clean while connecting/splicing fiber optic cables.
- All fiber optic connectors should be cleaned prior to connecting to the system
- Fiber connector protective caps should be installed on all non-terminated fibers and removed just before they are terminated.
- Check the fiber optic connections.
- Never look directly into the end of a fiber that may be carrying laser light. Laser light can be invisible and can damage your eyes.

2.5 RF Coaxial Cable Guidelines

2.5.1 General Cable Installation Procedures

Note: The installer should be familiar with the ANSI/TIA/EIS-568 Cabling Standard guidelines.

Observe the general cable installation procedures that meet with the building codes in your area. The building code requires that all cabling be installed above ceiling level (where applicable). The length of cable from the risers to each antenna may need to be concealed above the ceiling.

The cable must be properly supported and maintained straight using velcro cable ties, cable trays and clamps or hangers every 10 feet (where practical above ceiling level). Where this is not practical, the following should be observed:

- The minimum bending radius of the supplied ½” coax cable should be 7”.
- Cable that is kinked or has a bending radius smaller than 7” must be replaced.
- Cable runs that span less than two floors should be secured to suitably located mechanical structures.
- The cables should be supported only from the building structure.
- All cables shall be weather-resistant type.
- Cable length - determined by the system installation plan. When calculating the cable length, take into account excess cable slack so as not to limit the insertion paths.

2.5.2 RF Rules

- Use coax RG-223, 50 ohm, for RF connections between HX Indoor/Outdoor units and DAS antennas.
- When using the Corning system in an environment in which other indoor coverage systems are installed, it is recommended (where possible) that the antennas are placed at least two meters apart
- When bending coax cables, verify that the bending radius does not exceed the coax specifications.
- Use wideband antennas supporting a range of 700 MHz to 2600 MHz
- Terminate all unused HX RF ports with a 50 ohm load
- Make sure that the VSWR measured at the coax cable meets the product specification The VSWR must be measured prior to terminating the HX RF ports in the remote communication rooms.

2.5.3 Coax Cable Lengths and Losses

Use the compatible jumper to connect the coax connector to the external antenna.

Note: The required distance between the antennas (installed in the ceiling) depends on the infrastructure and calculated path-loss.

Table 2-1. Typical Coax Cable Lengths and Losses

Coax Length	Coax Loss (900 MHz)	Connector Loss	Total Loss
30	0.7	1.5	2.2
40	0.9	1.5	2.4
50	1.1	1.5	2.6
60	1.3	1.5	2.8
70	1.5	1.5	3
80	1.7	1.5	3.2
90	1.9	1.5	3.4
100	2.1	1.5	3.6
110	2.3	1.5	3.8
120	2.5	1.5	4
130	2.7	1.5	4.2
140	2.9	1.5	4.4
150	3.1	1.5	4.6
160	3.3	1.5	4.8
170	3.5	1.5	5
180	3.7	1.5	5.2
190	3.9	1.5	5.4
200	4.1	1.5	5.6

2.5.4 Cable Routing

Ensure all cables, e.g. power cable, feeder cable, optic fiber, commissioning cable, connecting are properly routed and secured so that they are not damaged.

2.6 Antenna Specifications and Guidelines

Determine the antenna installation configuration, according to the transmission and coverage requirements and the installation site conditions.

2.6.1 Authorized Antennas and Couplers

- External antennas - No limitation on any vendor of available external antennas with respect to the following requirements:
 - Omni Directional or Directional
 - Supported frequency range: wideband antennas supporting a range of 700 MHz to 2600 MHz
 - Gain: up to 12.5 dBi
 - Impedance: 50 Ohm
 - Types of couplers/splitters – depends on number of splits
- Couplers – Use N-Male to N-Female broadband coupler separately ordered from Corning (P/N AK-1COUPLER-NM-NF) or the equivalent:
 - Broadband frequency: 698 – 2700 MHz
 - -40 dB coupling (QMA coupling port)
 - Max. VSWR/Return Loss (dB): 1.15:1/-23.0
 - Max. Insertion Loss (dB): 0.2
 - Impedance: 50 ohms

2.6.2 General Antenna Installation Guidelines

- The wideband antenna should be installed at a convenient location, free of metallic obstruction (can also be installed in plenum spaces).
- Install the connected antenna at the designated height and tune it roughly toward the Service coverage area.
- Each individual antenna used for this transmitter must be installed to provide the separation distance as specified in the FCC grant from all persons during normal operation and must not be co-located with any other antenna for meeting RF exposure requirements

2.7 Grounding Requirement

Verify that the equipment has been well grounded (refer to the grounding lug on the bottom port panel of the HX Outdoor or on the rear panel of the HX Indoor). This includes antennas and all cables connected to the system. Ensure lightning protection for the antennas is properly grounded. Also, see sections 3.3.2 (HX Indoor) and 4.5.5 (HX Outdoor).

2.8 Manual Handling

During transportation and installation, take necessary handling precautions to avoid potential physical injury to the installation personnel and the equipment.

3 HX Indoor Physical Installation

This chapter describes the mounting procedure and physical connections for the HX Indoor (SISO/MIMO) Remote Unit.

3.1 Unpacking and Inspection

Unpack and inspect the cartons according to the following procedure

1. Open the shipping carton and carefully unpack each unit from the protective packing material.
2. Verify that all the parts have been received (see Table 3-1).
3. Check for signs of external damage. If there is any damage, call your Corning service representative.

Description	Quantity	
HX Indoor Cabinet (SISO/MIMO)	1	 
Power Cable (model dependent): <ul style="list-style-type: none"> • AC USA: Cable power, straight, USA 10A, UL, Black, 110V, L=1.8-2.5m (70.8 – 98.4 in) • AC Europe: Cable, power, W/Plug, 3Cond., Europe, L=1.8-2.5M (70.8 – 98.4 in) • DC: Power cable with open edges, L=2 M (78.7 in) Note: Image shown here is example of AC power cable	1	
19-in Rack Brackets - used for rack-mount installations	2 (R/L)	
Screws, 6-32X1/4, Flat HD, 100', Philips – used for assembling the rack-mount brackets on to the HX unit	12	
Wall Mount Brackets – used for wall-mount installations	2 (R/L)	
Screws, SEMS, 8-32X1/2, PAN, HD, Philips, Flat + Spring Washers – used for assembling the wall mount brackets to the HX cabinet	8	

Table 3-1. HX Indoor Package Items List

3.2 Mounting

The HX Indoor unit is installed in the communication room via one of the following options (each type of installation requires a different pair of brackets -both types supplied):

- Rack-mount
- Wall-mount (requires two people)

3.2.1 General Instructions

- Indoor type HX Remote Units should be installed in a communication room that provides access only to authorized personnel. The units are maintenance free. In the event of failure, only authorized personnel should handle the units.
- Environmental Data - Maximum ambient operating temperature: 50° C
- Maximum ambient temperature in a rack: 45° C

3.2.2 Rack Mount Installation

Rack Installation General Safety Instructions

Review the following guidelines to help ensure your safety and protect the equipment from damage during the installation.

- Only trained and qualified personnel should be allowed to install or replace this equipment.
- Verify that ambient temperature of the environment does not exceed 50°C (122°F)
- To maintain a low center of gravity, ensure that heavier equipment is installed near the bottom of the rack and load the rack from the bottom to the top.
- Ensure that adequate airflow and ventilation within the rack and around the installed components so that the safety of the equipment is not compromised.

To install the unit in a rack

1. Assemble the Rack Mount Brackets to the side panels of the HX cabinet using the (12) supplied screws.

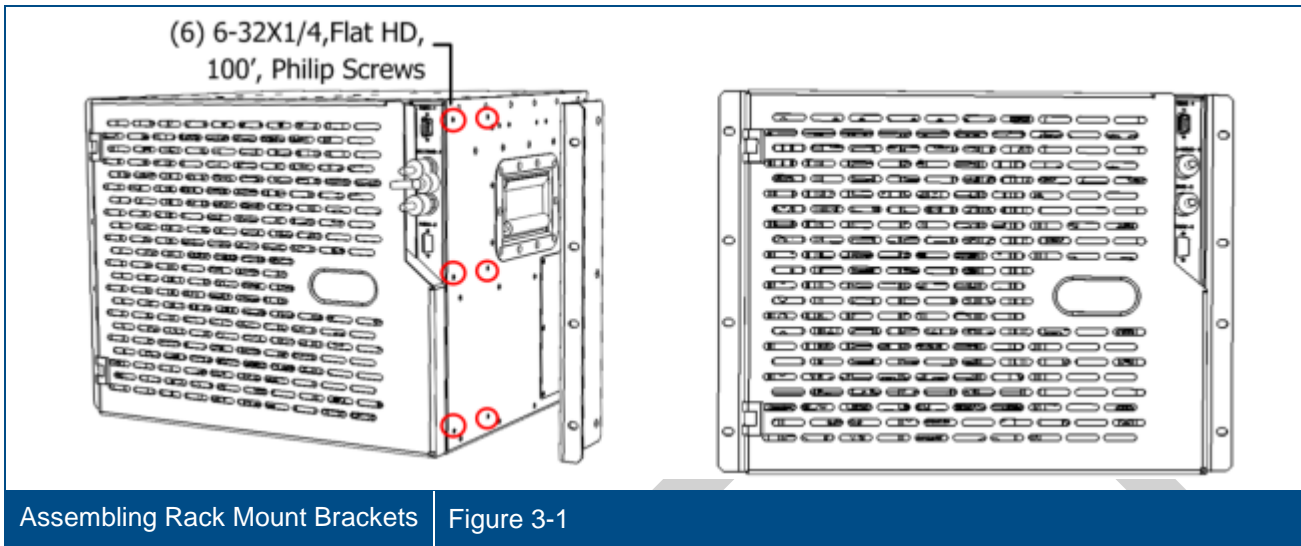

2. Install the unit in the 19-in communication rack and secure to the frame using the appropriate rack screws.

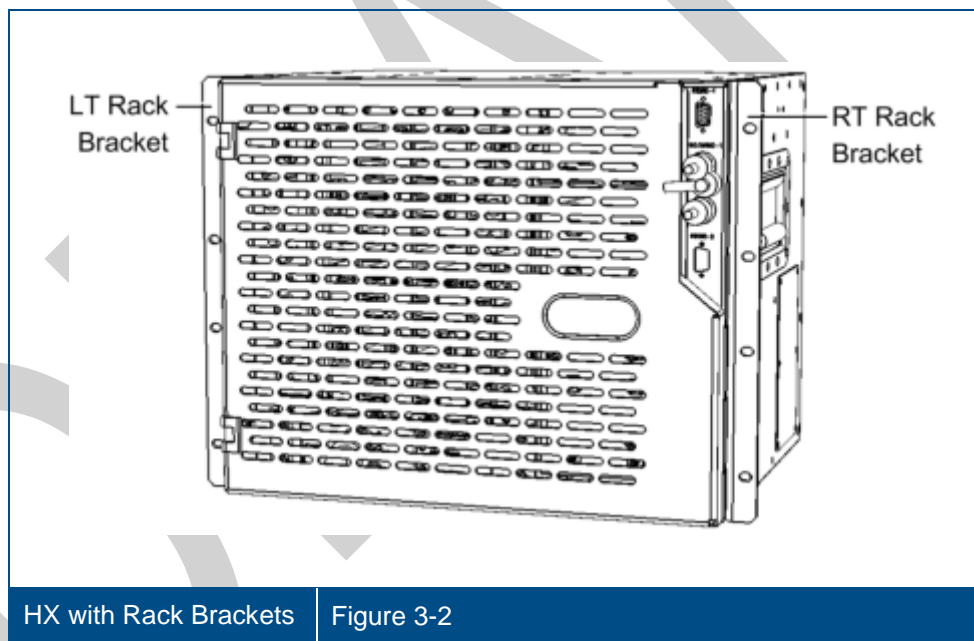

3.2.3 Wall-Mount Installation

The wall-mount installation procedure references an installation on concrete walls/solid block walls.

3.2.3.1 Required/Recommended Tools and Materials for Wall Mount Installation

- Expanding lead shield anchors with 3/8" lag bolt with hex head bolts should be used (McMaster-Carr catalogue number 92403A200, or equivalent).
- Hex bolts need to be at least 3" in length
- Kobalt 3/8-in Drive Click 20 Ft-lbs - 100 Ft-lbs Torch Wrench Model #85601 or similar
- Kobalt Crows foot wrench
- Kobalt ratching wrench
- M18™ Cordless Lithium-Ion High-Performance ½" Hammer Drill/Driver

3.2.3.2 Mounting HX on Wall

Note: The HX unit should be mounted on concrete/hollow block walls only.

1. Assemble each wall-mount bracket to the side of the of the cabinet rear panel using the 8-32X1/2,PAN, HD, Philips, Flat screws and washers (four per bracket). See Figure 3-3.

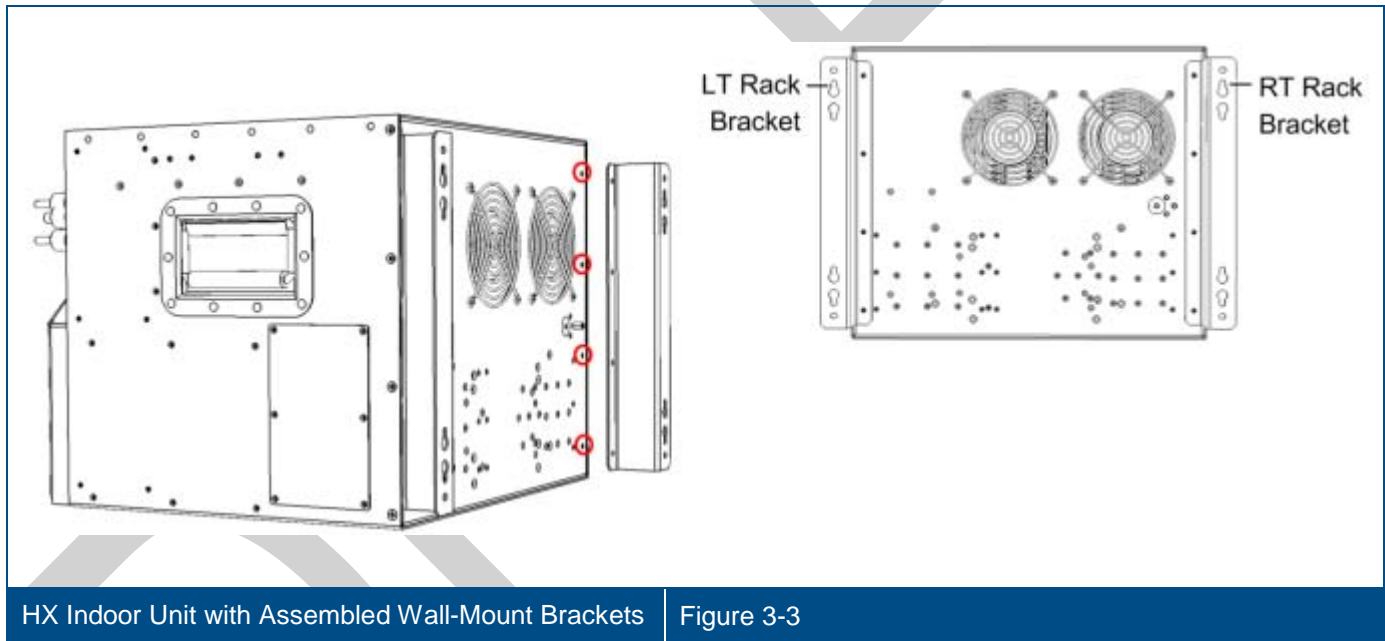

2. Referring to Figure 3-5, prepare the appropriate anchors in wall:

- Using the bracket keyholes as guides, mark the location of the four holes (two per bracket) to be drilled in the wall. See Figure 3-4 – dimension in mm).
- Using a hammer drill, drill holes for expanding lead shield anchors. Refer to Figure 3-4 for keyhole dimensions.
- Clean the debris from the anchor holes.
- Fill the 4 holes with silicon to help weather-proof the drilled holes and to prevent erosion.
- Tap in expanding lead shield anchors
- Insert bolts in anchors and tighten until bolt head is 0.5" from surface of wall.

3. Mount the HX using key-hole designations onto the 4 bolts. See Figure 3-6.

4. Tighten the 4 wall mount lag bolts with an appropriate size wrench, socket or speed wrench.

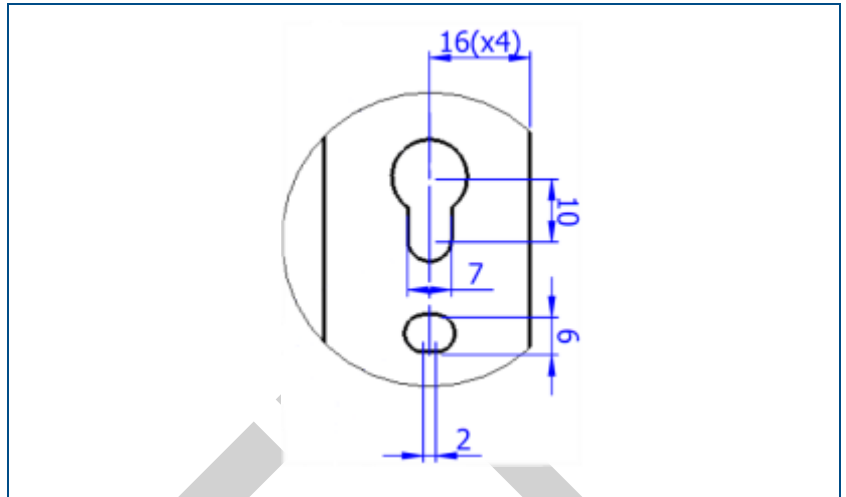

Wall Mount Bracket Keyhole Dimensions Figure 3-4

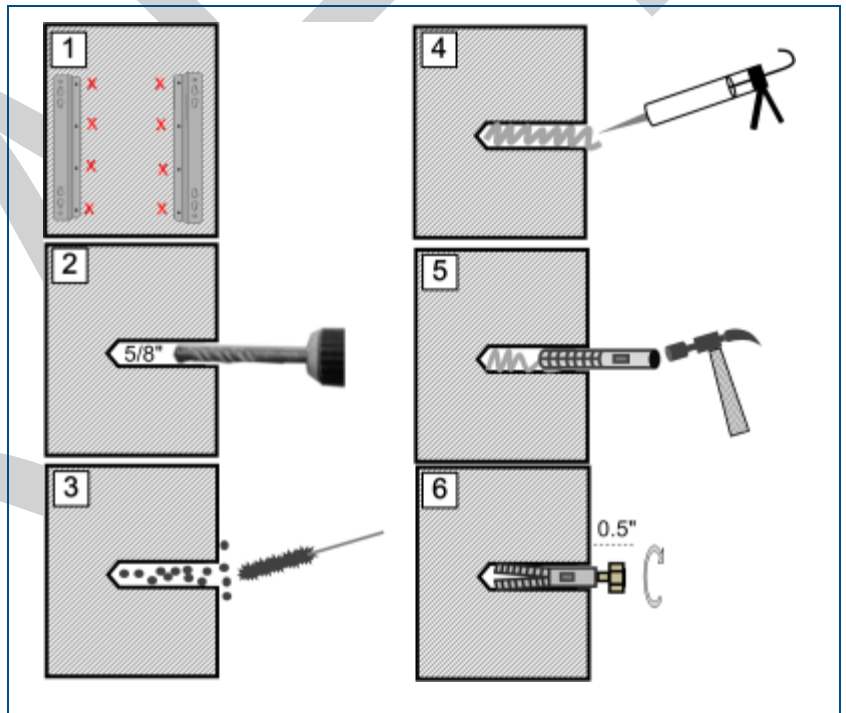

Inserting Anchors Figure 3-5

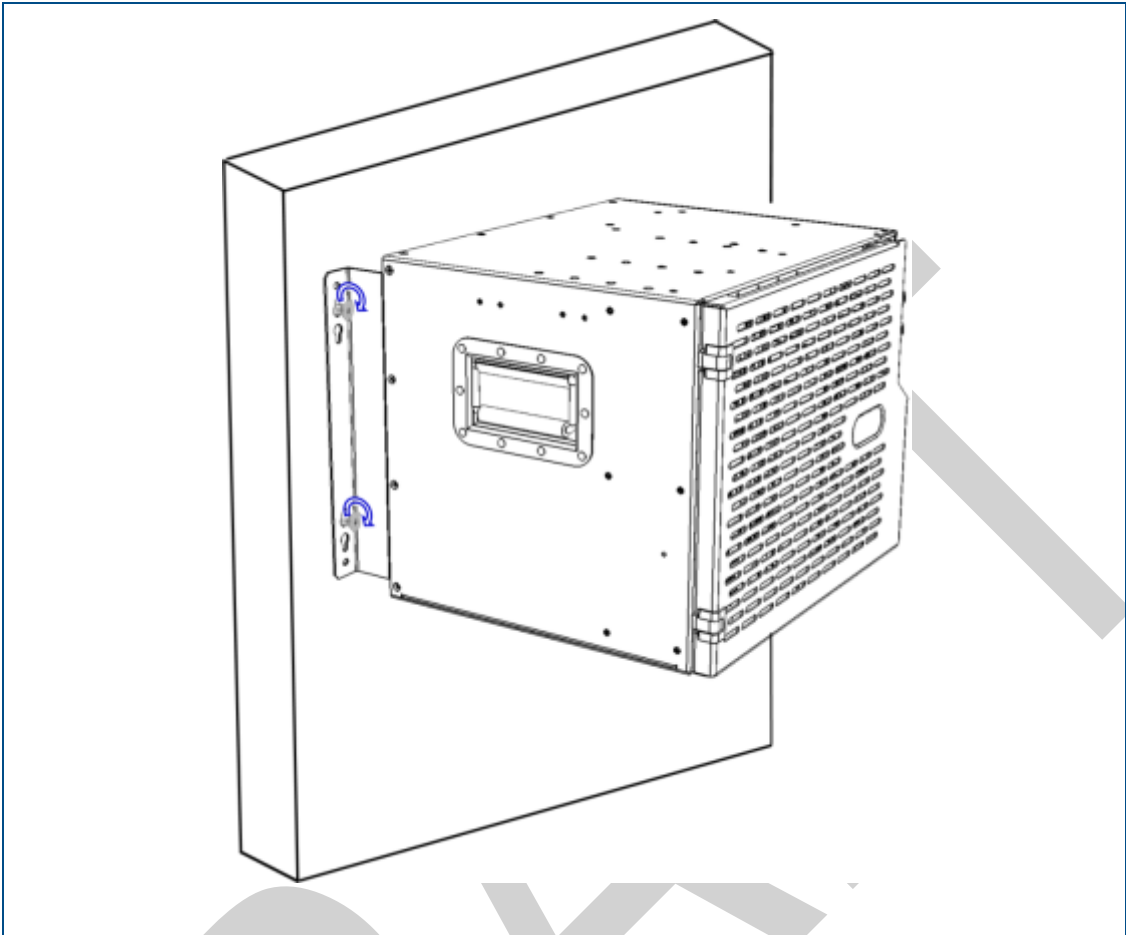

Wall Mounted HX Indoor | Figure 3-6

3.3 Connections

3.3.1 RF and Fiber Connections

Connect the HX Indoor unit RF and Fiber connections as follows

1. Connect broadband antenna coax to (duplexed) ANTENNA PORT (two for MIMO models) located on the right of the cabinet front panel (external). See Figure 3-7.
2. Open cabinet door.

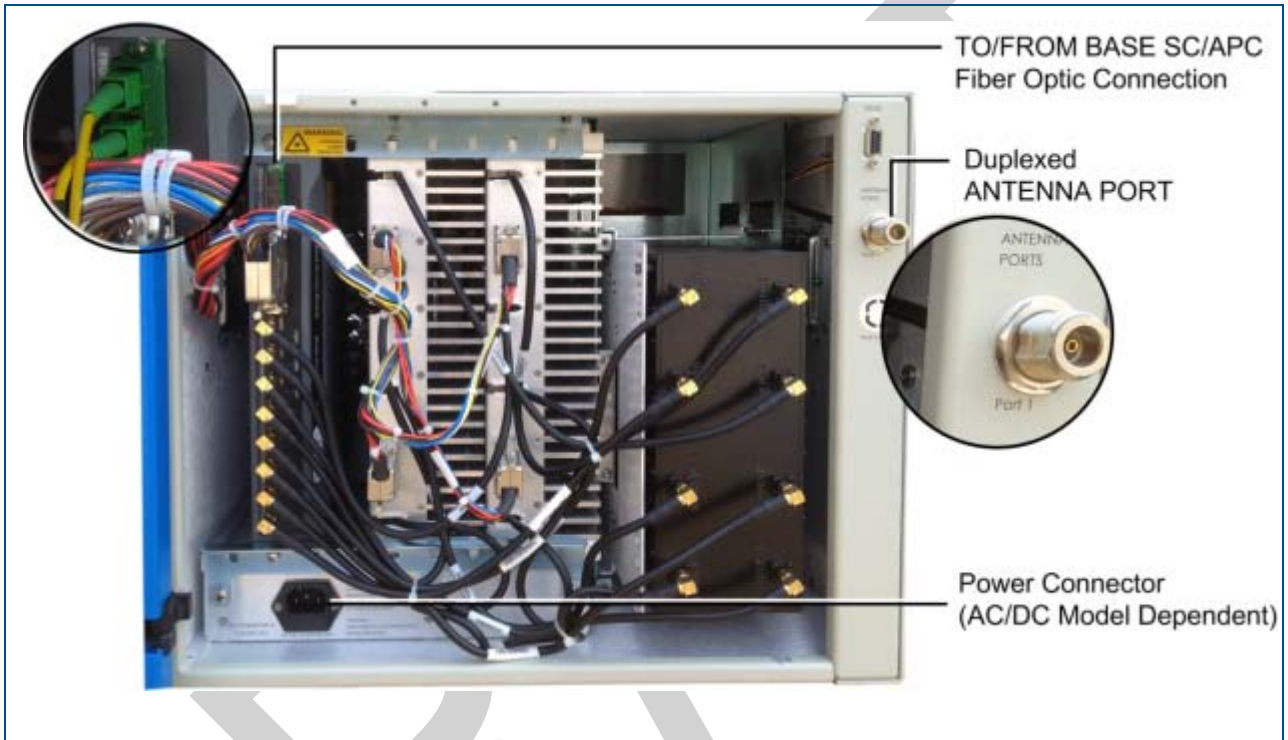

HX Indoor Connections – SISO | Figure 3-7

3. Connect fiber as follows (two connections for MIMO models):
 - Install splice box near Remote Cabinet.
 - Connect fiber optic cable to splice box and the SC/APC pigtails to the HX RHU module (MIMO models include two service modules with fiber connections).
 - Downlink: Connect the fiber optic cable pigtails from splice box, which comes from the BU/OCH port, to the corresponding RHU SC/APC TO BASE and FROM BASE optic ports of the service module(s).
 - Uplink: Connect the fiber optic cable pigtails from splice box, which comes from the RHU service module(s), to the uplink port that connects to the BU/OCH.

Note: Keep in mind the rules for handling and connecting F/O cables. The F/O cables will be connected to the associated OCH in the communication room at a later phase.

3.3.2 Ground Connection

- AC Cabinets - Mandatory
- DC Cabinets - Recommended

Connect the HX cabinet to the main grounding point in the rack via the terminal stud located on the rear of the unit (ground wire with terminal not supplied).



3.3.3 Power Connections

The power supply connections depend on the HX model (AC or DC). Each type of model is supplied with corresponding power cable.

Power Consumption for HX Indoor models:

- SISO: 340 W
- MIMO: 500 W

3.3.3.1 AC Models

Connect the supplied AC power cable to the HX AC power connector (100/240 VAC; 50/60 Hz; 8A Slow Blow Fuse) and to the power source. See Figure 3-9 for AC connector.

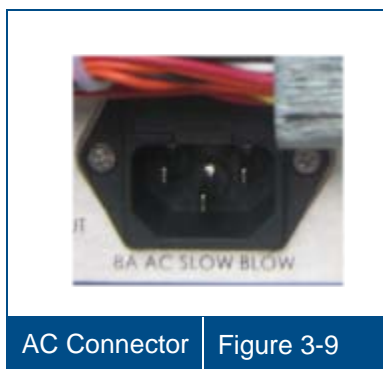

3.3.3.2 DC Models

DC Wiring

Note the following:

- The HX Indoor (DC model) 18 pin DC Input terminal block connector supports 20-30 AWG wires
- Maximum current allowed per pin: 5 A

1. Referring to Figure 3-13, connect wires as follows:

- Higher voltage wires from the DC source to RED wires of the DC cable jumper.
- Lower voltage wires to the BLACK wires of the cable jumper.

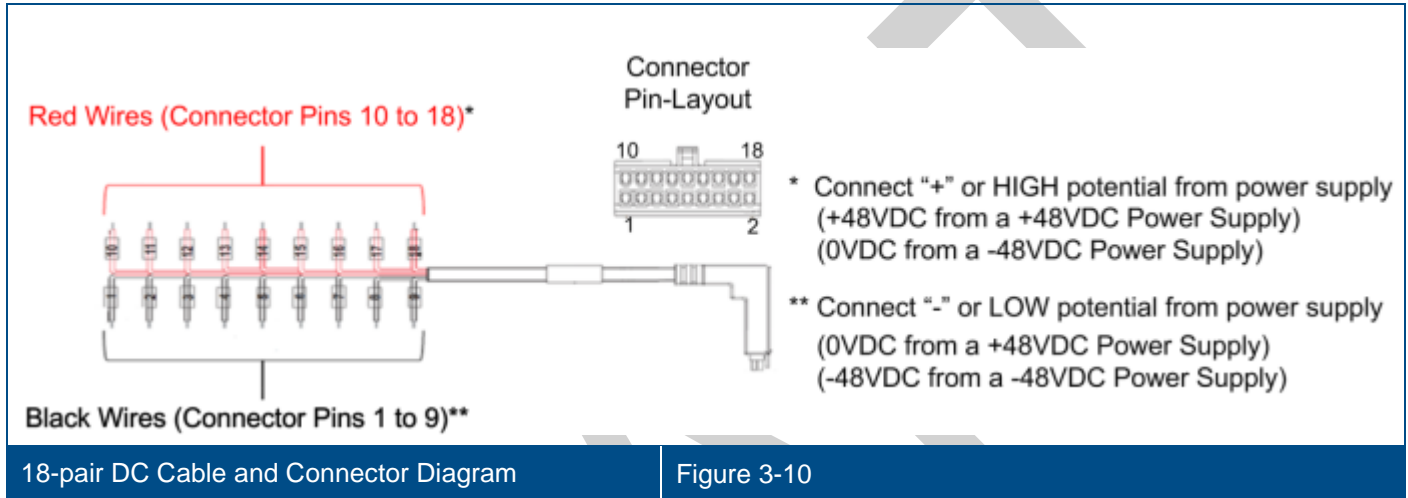

2. Connect the DC cable jumper to 'DC in' power connector (see Figure 3-11).

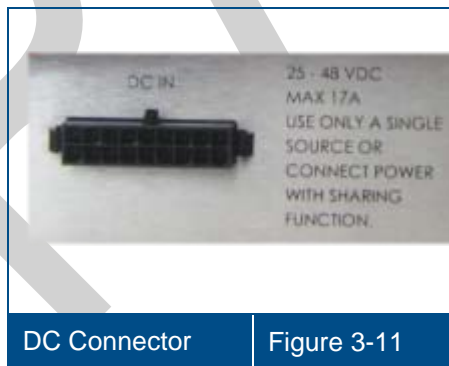

3. A voltmeter should read +48V when it's negative side is connected to the black wire and positive side to red wire of the HX jumper cable.

3.3.4 Routing Fiber and Power Cables

Route the fiber and power cables as follows (and close cabinet door):

- Fiber cables - route towards the top of the cabinet
- Power cable - route towards bottom of cabinet

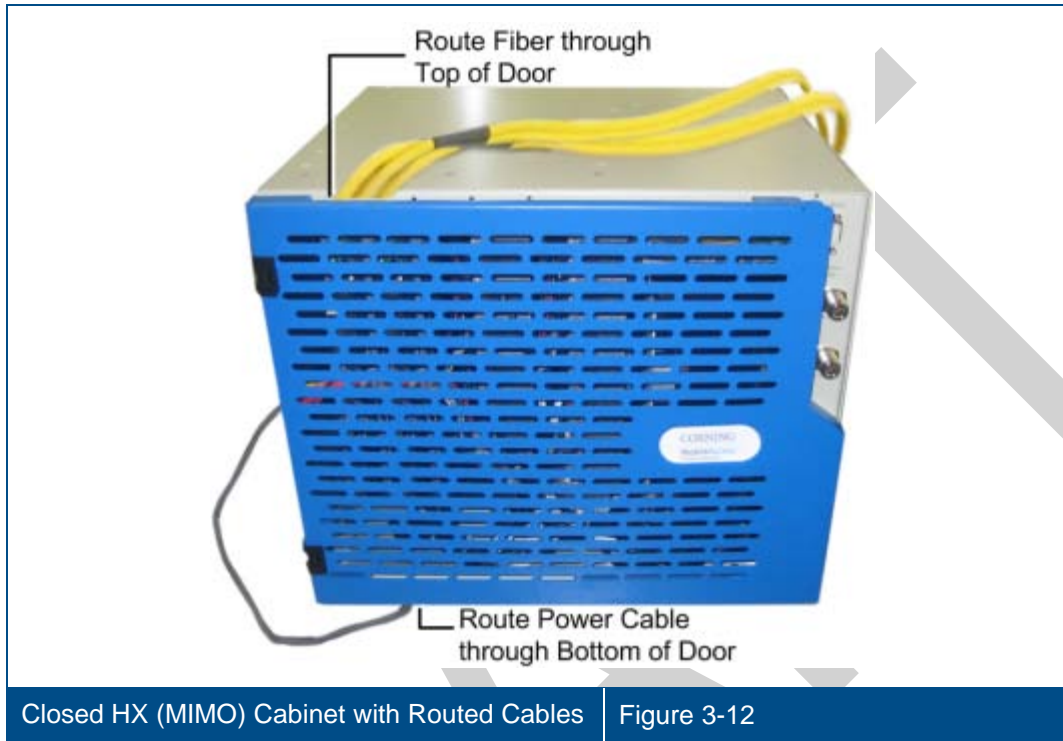

3.4 Verify Normal Operation

Verify normal system operation via the service module(s) LEDs:

- PWR and Link: Steady Green
- COMM: Blinking Green

If the LEDs are not as described above, refer to HX Unit Interfaces - 1.4.1.1 or 1.4.1.2 for complete description of LEDs.

The LED indicators are the same in both SISO and MIMO model service modules. Figure 3-13 shows an example of the LEDs on the two service modules in a MIMO unit (SISO units only include one service module).

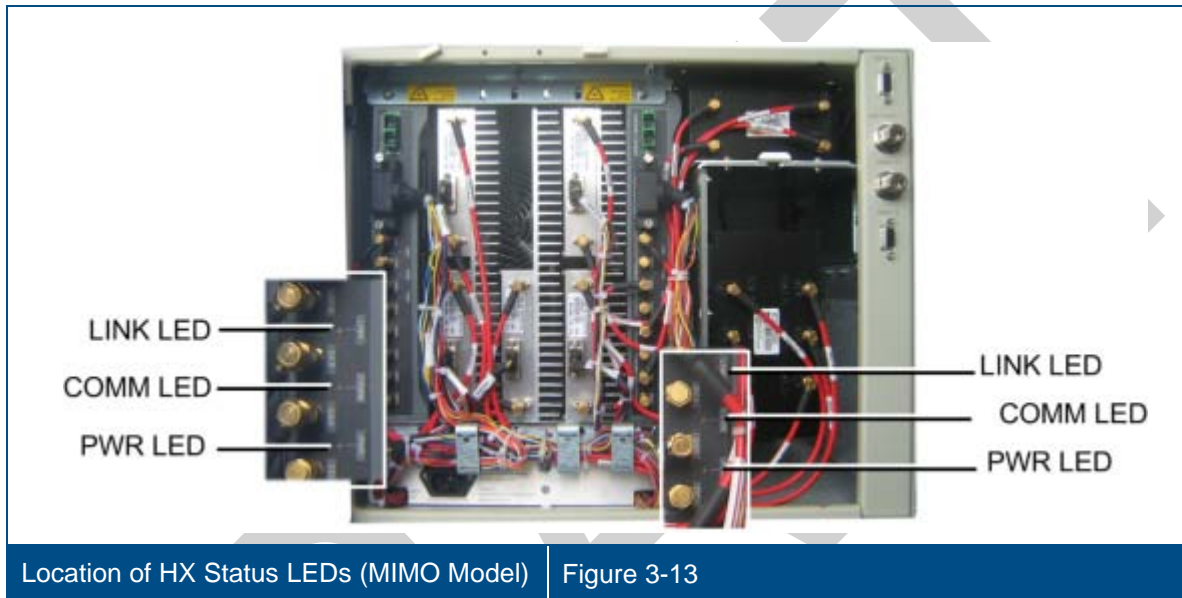

Note: The HX monitoring and management capabilities are performed via the host OCH unit. Refer to the SC-450 User Manual for the configuration and management options.

4 HX Outdoor Physical Installation



4.1 General Information



- The HX Outdoor Remote Unit can be installed either on a wall or on a pole (brackets are provided to facilitate both options).
- The unit weighs 40 kg (88.2 lbs). This requires two people or the use of a crane (from top ring) to lift the unit onto the pole.
- The wall mount and pole mounting procedures described in this document are recommendations for the specified scenarios. The installer should do the homework to use the proper hardware and industry standard mounting procedure required for installing 88lbs unit on the varying types of wall & pole scenarios that could exist in the field.
- The wall mounting and pole mounting scenarios are modeled and simulated for hurricane and zone-4 earth quake impact per GR-487 standard.
- All outdoor or weather/water exposed installations need to use stainless steel or hot-dipped galvanized anchors.
- The HX Outdoor unit must be mounted with the connectors facing down.
- The power connections are model dependent – refer to the wiring guide (supplied with each unit) for the connections to the HX power connector.
- Ensure that the HX is properly grounded (refer to the grounding feature on the bottom port panel of the HX).

4.2 Unpacking and Inspection

Unpack and inspect the packages as follows:

1. Open the shipping carton and carefully unpack each unit from the protective packing material.
2. Verify that all the items have been received.
3. Check for signs of external damage. If there is any damage, call your Corning Optical Communications service representative.

Description	Quantity	Image	P/N
HX Outdoor Remote Unit Cabinet	1		HX-C85P19L70A17-AC-B (or) HX-C85P19L70A17-DC-B (or) HX-C85G91D18U21-AC-B (or) HX-C85G91D18U21-DC-B (or) HX-G90D18U21-AC-B (or) HX-G90D18U21-DC-B
Four Hole Bracket Template for marking required holes for drilling	1		
Flat Washer, 3/8"	8		631F000801
Nut, 3/8, DIN 934 -3/8 UNC	8		631N001001
Spring Washer, 3/8"	8		631P000501
Hex Cap Screw, 3/8 x6", Head 9/16	8		631S002901
Power cable with open edges Length=10 M.	1		HX Outdoor AC - 705A030451 (AC cable) HX Outdoor DC - 705A030851 (DC Cable)
Conn. 1-20UNEF, Receptacle, solder f/cable, waterproof	1		HX Outdoor AC - 616A010401 (3 Pins) HX Outdoor DC - 616A011801 (8 Pins)

Description	Quantity	Image	P/N
Boot, straight, lipped, fluid-resistant elastomer 23 to 10 mm	1		634A004501
Pole Clamp	4		264A088302
HX, Outdoor, Profile for wall installation – iron bar used for protecting the HX from vertical displacement	1		264A174201
Anchor nut (JUMBO),HEX 1/2,NUT 7/16,L=60mm,inner 5/16, SS	2		631A004601

4.3 HX Outdoor Dimensions

The following figures show the HX Outdoor unit Figure 4-1 and bracket dimensions (Figure 4-2).

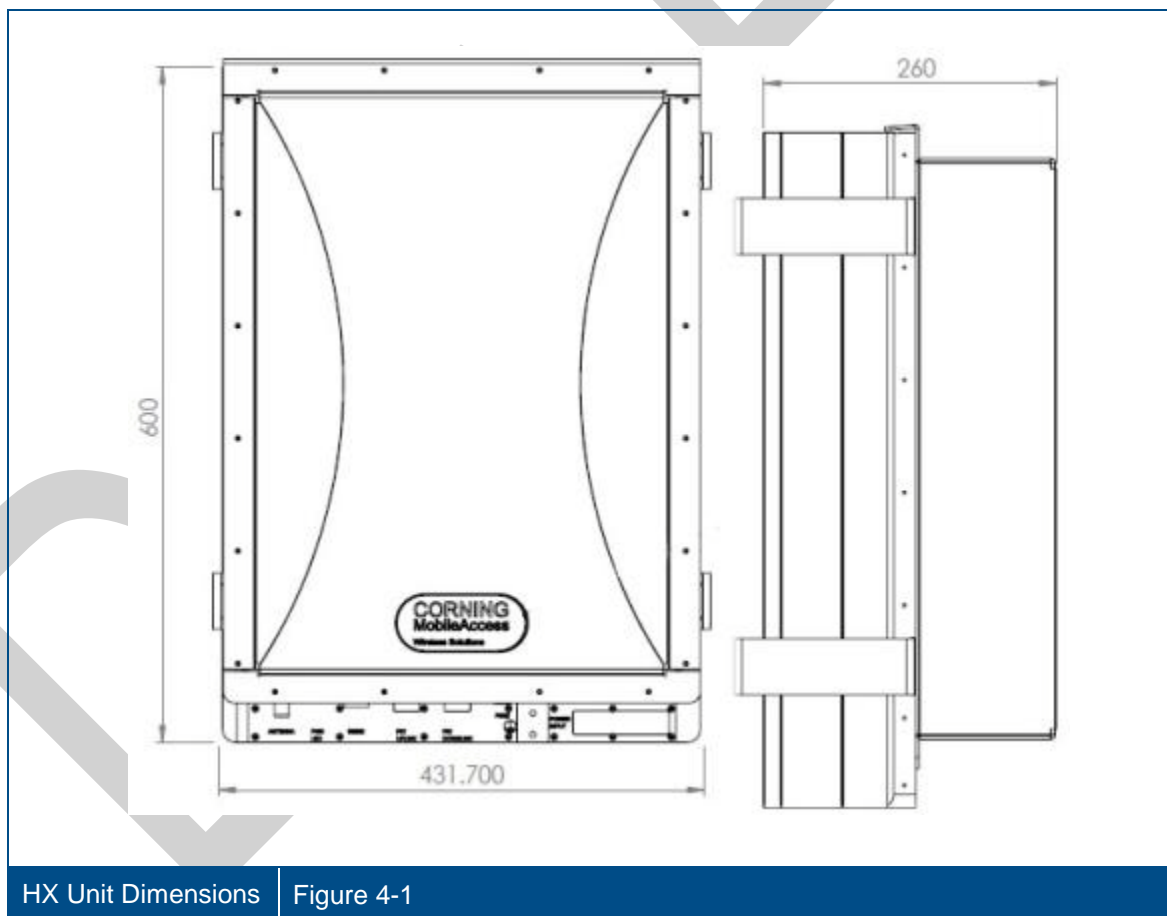

HX Unit Dimensions | Figure 4-1

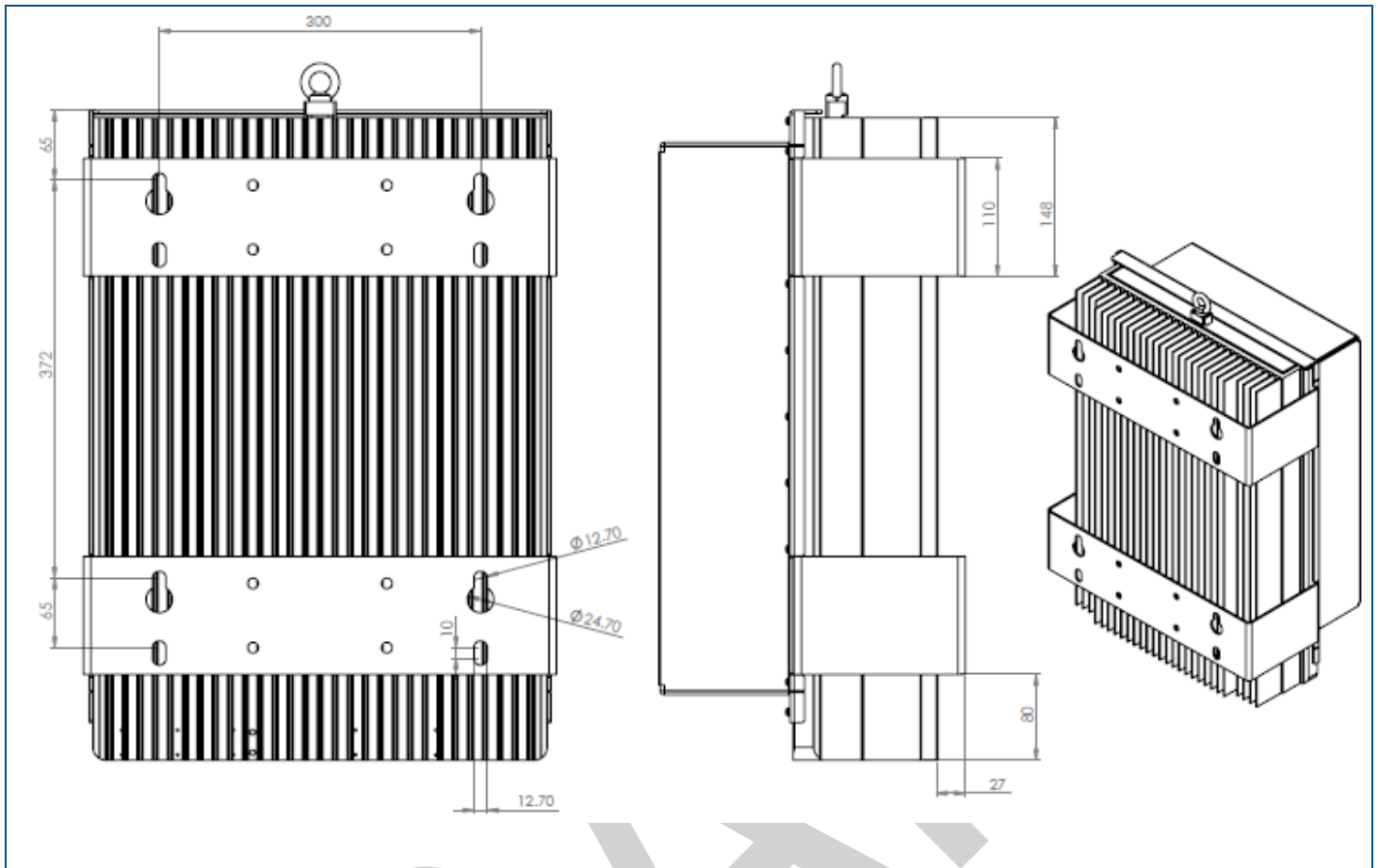

HX Outdoor Bracket Dimensions | Figure 4-2

4.4 Required/Recommended Tools and Materials for Wall Mount Installation

- Expanding lead shield anchors with 3/8" lag bolt with hex head bolts should be used.
- Hex bolts need to be at least 3" in length
- Hex heads on bolts need to be >12.7 mm and <24.70 mm to fit bracket key-holes
- Recommended Anchor is Powers 3/8" Long lag shield with 3/8" X 3" HDG or SS Lag bolt or similar
- Kobalt 3/8-in Drive Click 20 Ft-lbs - 100 Ft-lbs Torch Wrench Model #85601 or similar
- Kobalt Crows foot wrench
- Kobalt ratching wrench
- M18™ Cordless Lithium-Ion High-Performance ½" Hammer Drill/Driver

4.5 Mounting

4.5.1 Wall Mount Installation

Note the following:

- The wall-mount instructions provided in this section reference installations on concrete/ solid block /brick walls.
- The brackets required for mounting the unit on the wall are integrated in to the rear panel – no required assembly.

To wall-mount the HX Outdoor Remote Unit

1. Select the wall mount location according to the following criteria:

- General surroundings
- Shielded, ventilated, and easy-to-reach area (for maintenance and on-site inspection)
- Proximity to the antenna in order to minimize cable loss

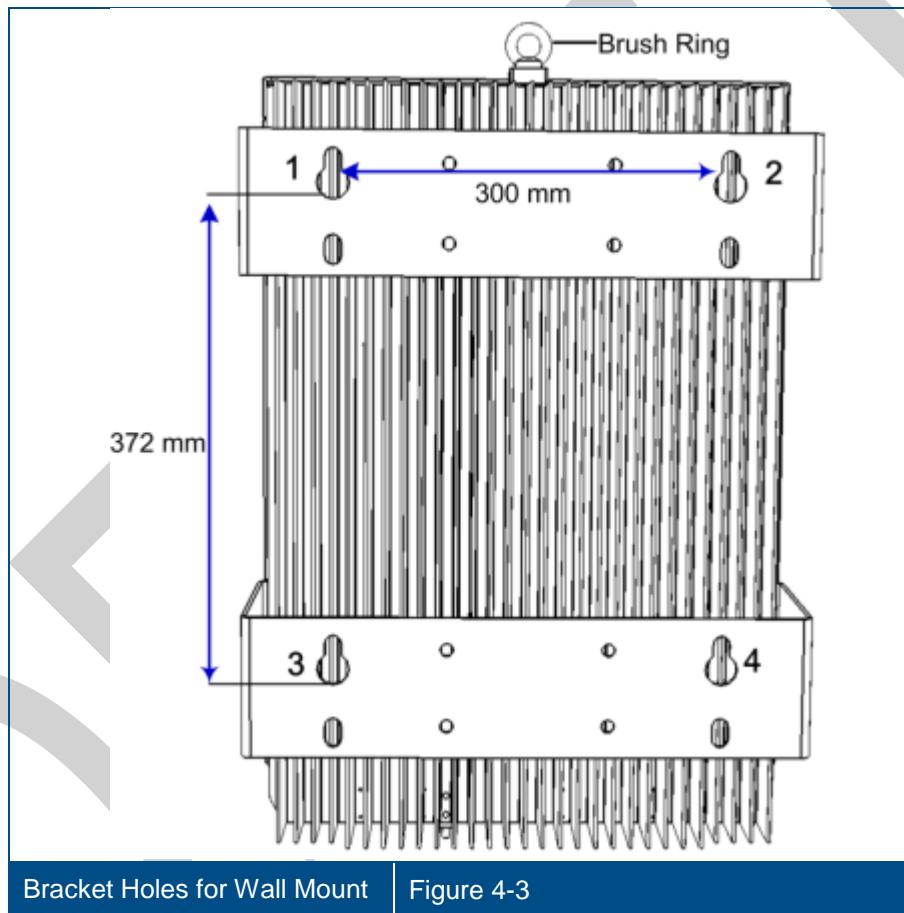

2. Referring to Figure 4-4, insert the anchors for mounting the unit as follows:

- Use the provided four hole template to mark the location of the holes to be drilled in the wall.

Note: Key holes are 300 mm apart from each other horizontally (center to center) and 372 mm apart vertically (see Figure 4-3).

- Using a hammer drill, drill 5/8" holes for expanding lead shield anchors.
- Clean the debris from the anchor holes.
- Fill the 4 holes with silicon to help weather-proof the drilled holes and to prevent erosion.
- Tap in expanding lead shield anchors
- Insert bolts in anchors and tighten until bolt head is 0.5" from surface of wall.

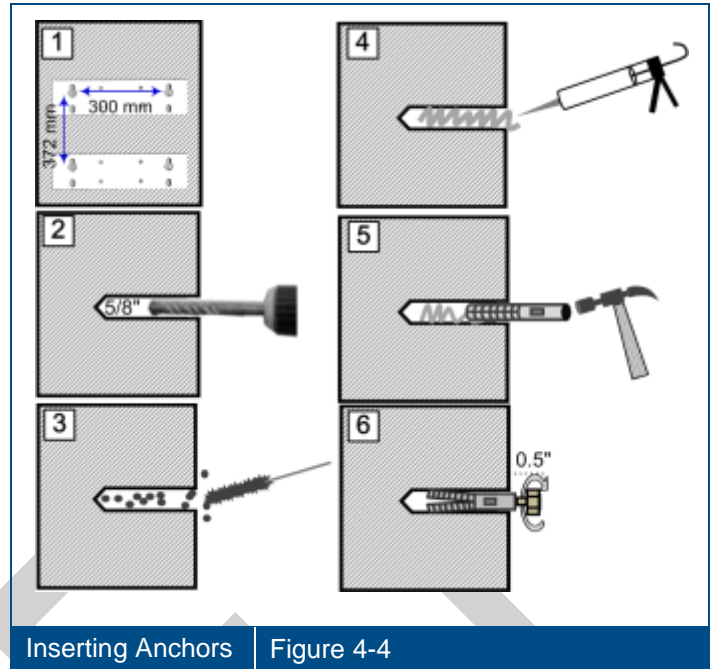

3. Mount the HX using key-hole designations onto the four bolts.

Note: Brush ring (see Figure 4-3) is intended for the purpose of lifting the HX unit. However, it can also be used for additional safety measure such as tethering the HX unit via the brush ring using a steel cable of sufficient strength to withstand the units' weight to an adequate alternate anchor point.

4. Reach behind the mounting bracket and tighten the 4 wall mount lag bolts with an appropriate size wrench, socket or speed wrench. See Figure 4-5.

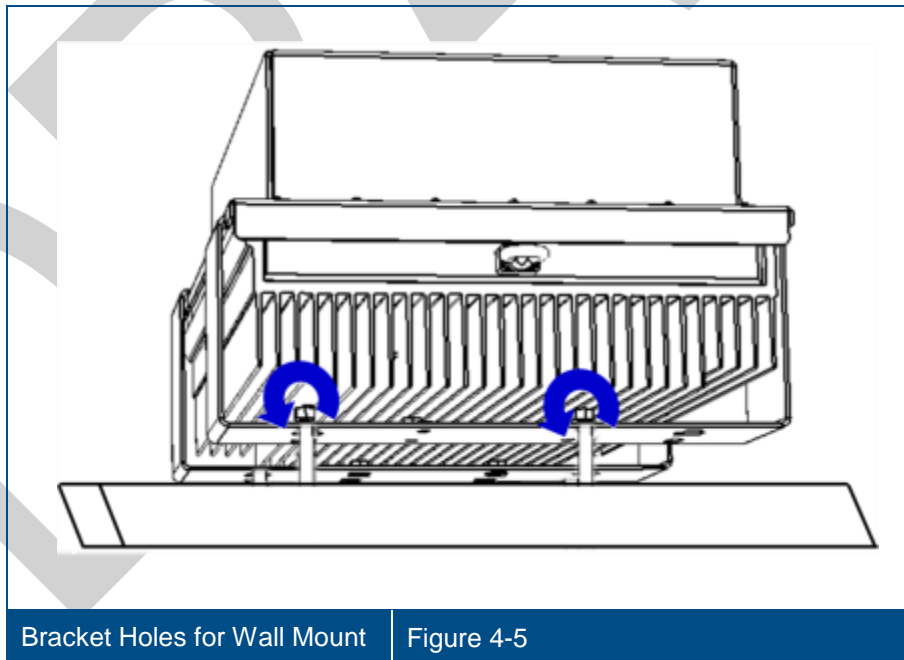

Note 1: If it is determined that a washer is needed for a secure installation the washer should not be more than 20 mm OD.

Note 2: Recommended torque = 8 ft/lb

5. Referring to Figure 4-7, install the metal profile:

- Drill two holes for the profile anchors (provided), using the profile holes as a guide
- Place the metal profile behind the HX unit-above the bracket, insert the anchors in the wall and tighten

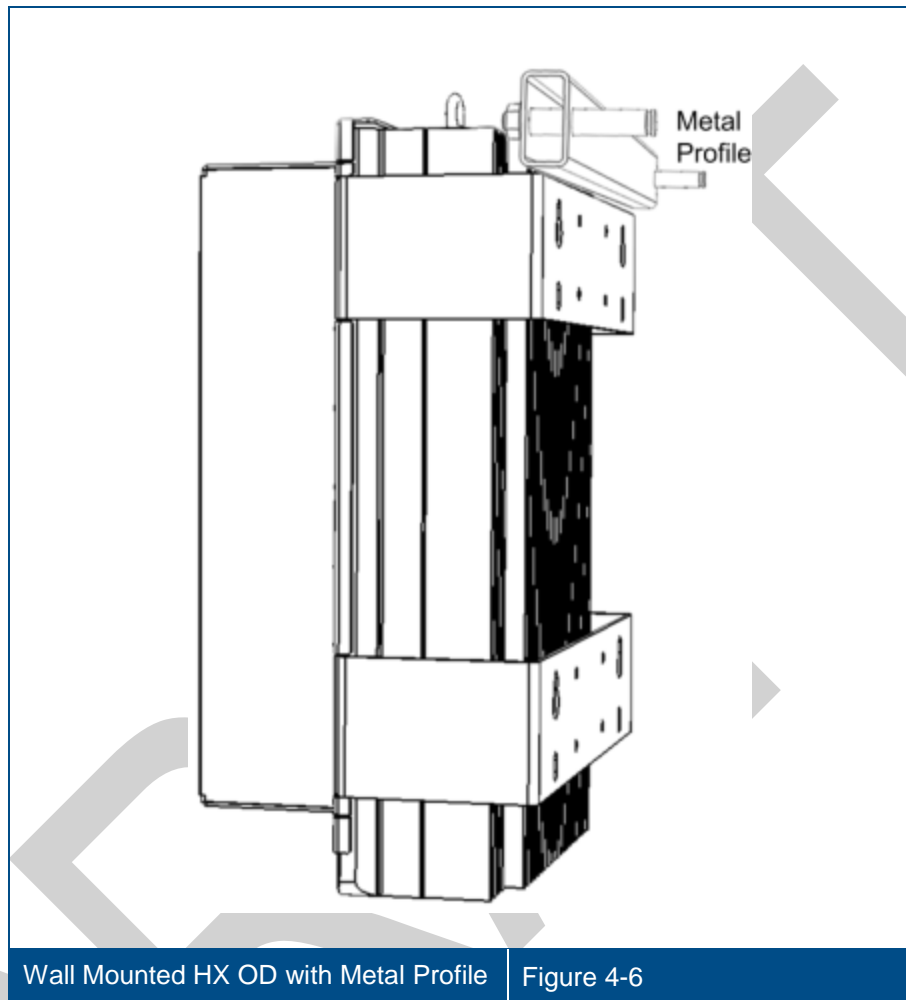

Wall Mounted HX OD with Metal Profile | Figure 4-6

4.5.2 Pole Mount Installation

The pole mount installation procedure consists of positioning the pole clamps on the pole and mounting the HX Outdoor unit on them.

Note the following:

- Provided pole mounting accessories are designed for the pole radius thickness range, Ø63 – Ø95 mm
- The pole mount installation requires the following provided items (see section 4.2):
 - (4) Pole clamps
 - (8) Washer, Flat, 3/8"
 - (8) Nut, 3/8, DIN 934 -3/8 UNC
 - (8) Washer, Spring, 3/8"
 - (8) Screw, Hex Cap, 3/8 x6", Head

To pole-mount the HX Outdoor Unit

1. Select the appropriate location according to the following criteria:
 - Accessibility
 - Antenna location and distance
2. Position and hold an outer top bracket on the pole.
3. Insert supplied spring washer and screw-hex-cap (four per bracket) momentarily support it with your hands.
4. Fit the screws through the inner clamp and secure loosely so that the distance between the clamps is adjustable.

5. Lift the HX Unit and fit the clamp bolts into the four middle holes of each bracket, as shown in Figure 4-7:

- Top pole clamp bolts into top middle HX bracket holes
- Bottom pole clamp bolts into bottom middle HX bracket holes

Note: Brush ring (see Figure 4-7) is intended for the purpose of lifting the HX unit. However, it can also be used for additional safety measure such as hanging the HX unit via the brush ring using a steel cable of sufficient strength and tying it to an iron bar of enough strength.

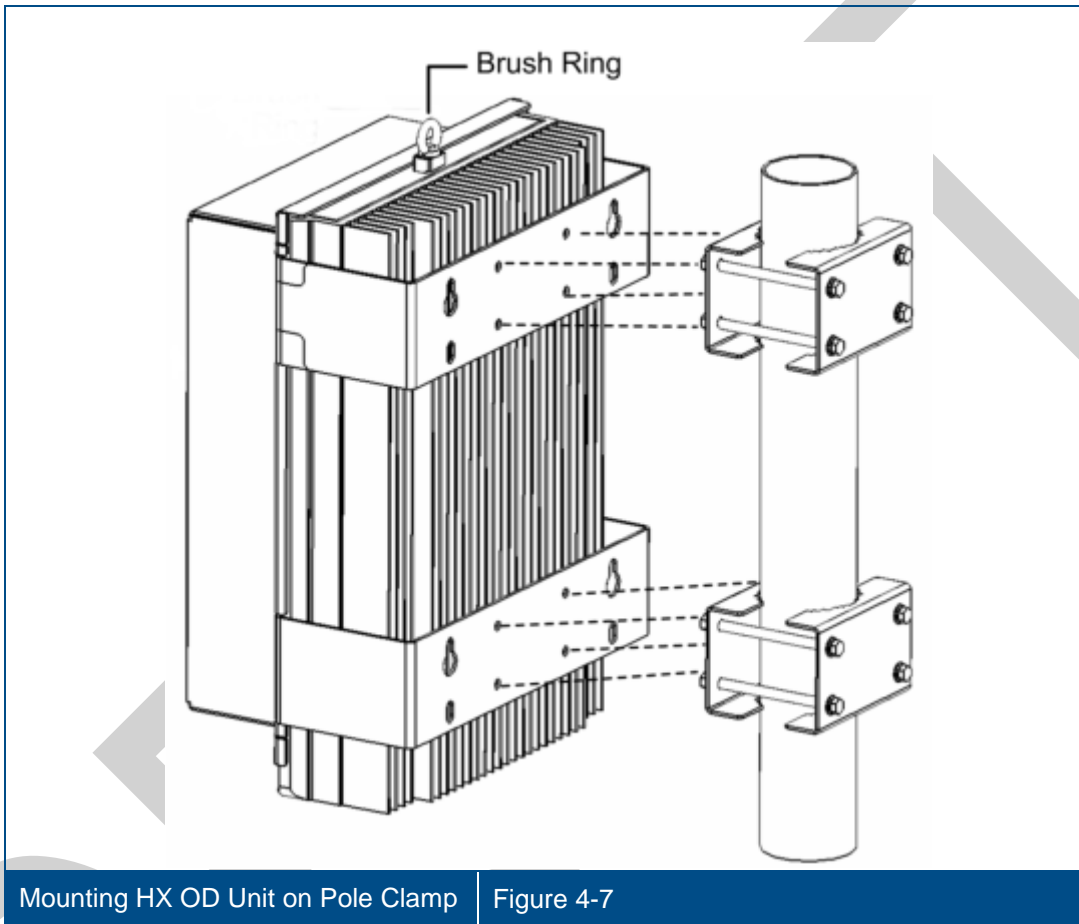

6. Referring to Figure 4-8, reach behind the HX unit brackets and secure each screw with the washers and the nuts.

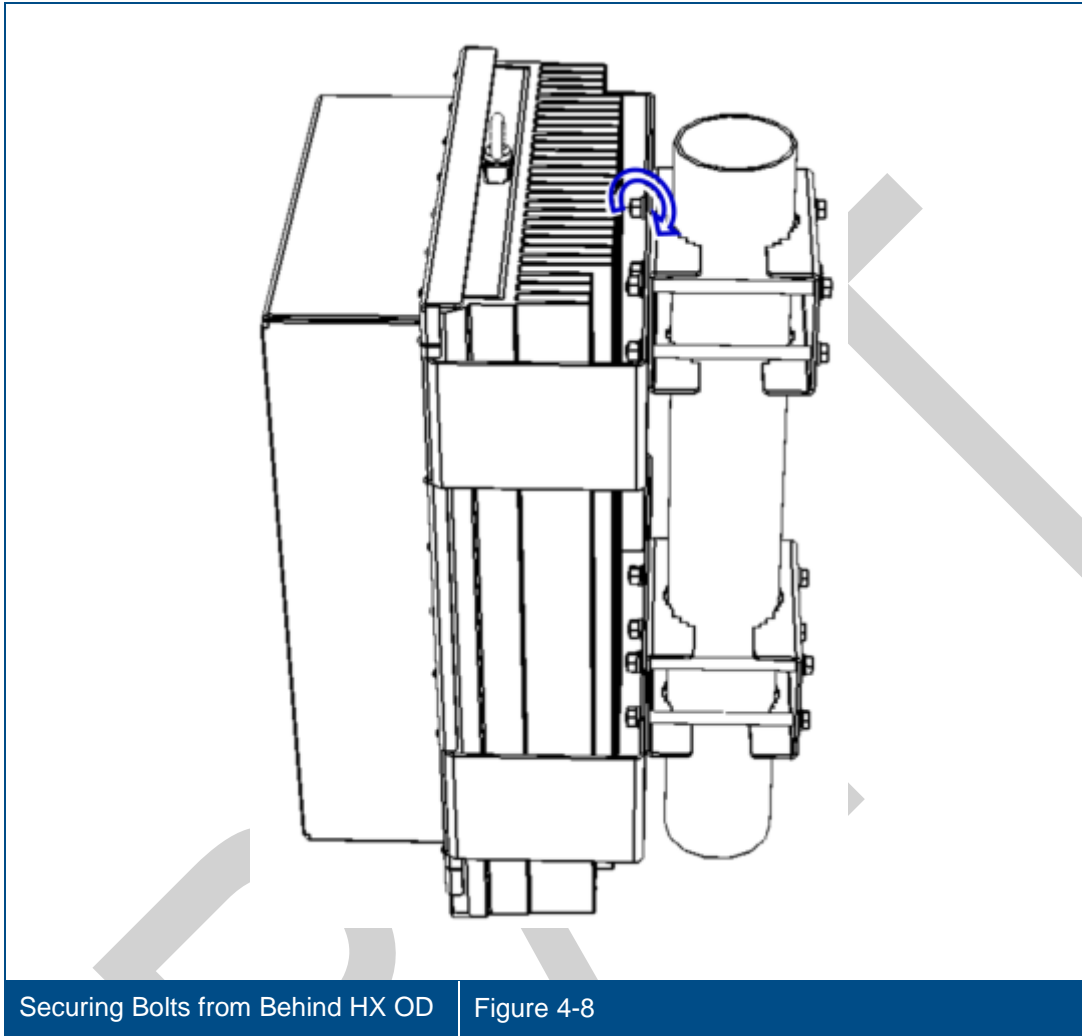

4.6 Connections

The HX Outdoor connections are performed from the underside of the HX unit after it has been mounted. The main connections include the RF, fiber and power connections. These connectors are waterproof and are protected by covers when not connected. Remove the connector waterproof covers when connecting cables.

4.6.1 RF and Fiber Connections

To connect the RF and fiber cables

1. Connect the RF antenna coax cable to the HX ANTENNA port.
2. Connect the (Corning OptiTap®) fiber cable to the HX F/O UPLINK and F/O DOWNLINK OptiTap® connectors as follows:

IMPORTANT! OptiTap™ pullout force ranges from a few lbs to 50+ lbs with the dust cap or connector installed. This prevents damages caused to the DAS unit.

- Downlink: Connect the fiber optic cable from splice box, leading from the OCH port, to the corresponding F/O DOWNLINK OptiTap®.
- Uplink: Connect the fiber optic cable from splice box, leading from the HX F/O UPLINK OptiTap® port, to the uplink port leading to the OCH.

Note: Keep in mind the rules for handling and connecting F/O cables. The F/O cables will be connected to the associated OCH in the communication room at a later phase.

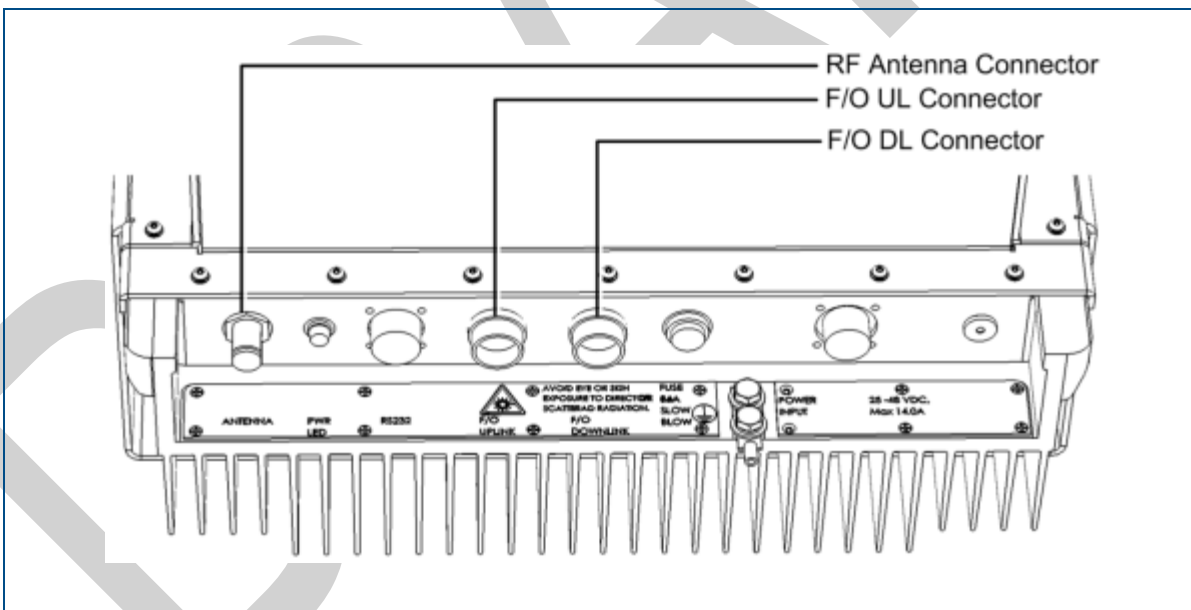

HX RF and Fiber Connectors | Figure 4-9

4.6.2 Ground Connection

The grounding connection is performed via a two hole, standard barrel grounding lug (LCD10-14A-L Panduit) located on the HX connectors' panel (see Figure 4-10):

- For use with stranded copper conductors
- 10-14 AWG
- Holes - ¼ inch
- STR

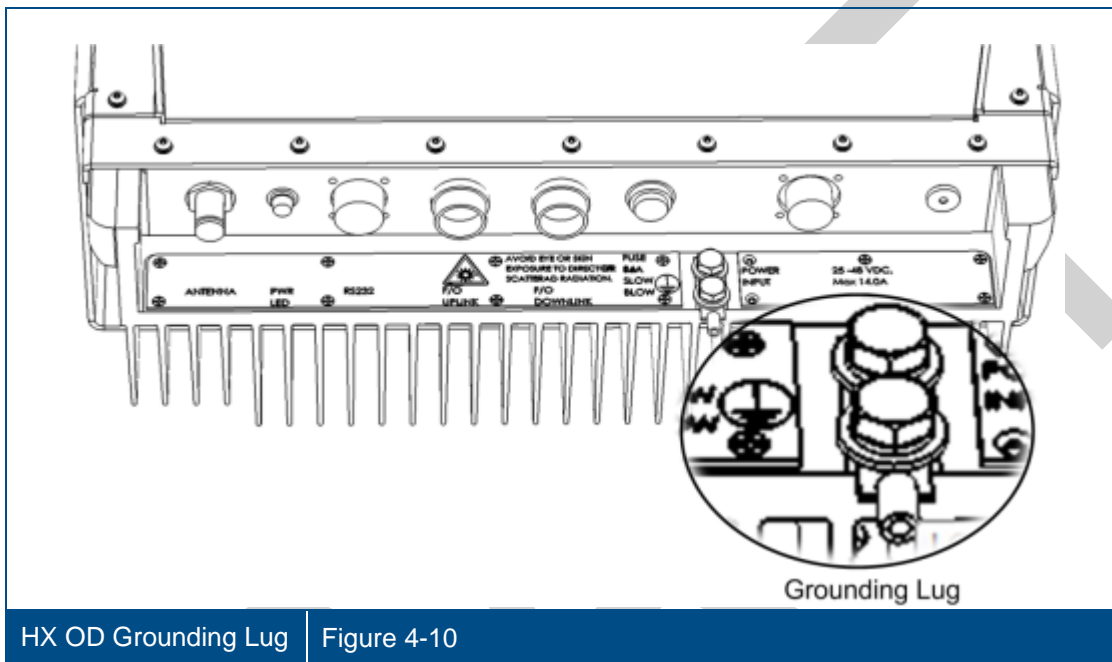

HX OD Grounding Lug | Figure 4-10

4.6.3 Power Connections

The HX Outdoor power connector is model dependant (AC/DC). Each HX Outdoor Remote unit includes a non-standard power connector which requires the proper wiring. Wiring instructions are provided for both AC and DC models.

4.6.3.1 AC Power Input Model Connections

Note: Refer to Appendix D for the HX OD AC power cable specifications.

Connect the power cable wires according to the wire connection in Table 4-1 and Figure 4-11.

Pin	Wire Color	Function
A	Yellow/Green	GND
B	Blue	N
C	Brown	L

Table 4-1. Wire Connections

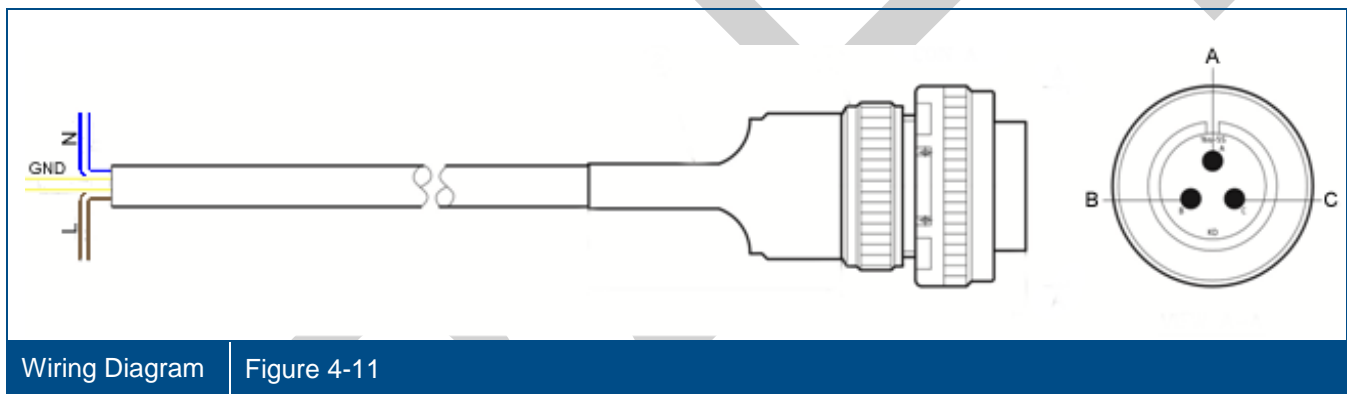

4.6.3.2 DC Power Input Model Connections

Note: Refer to Appendix D for the HX OD DC power cable specifications.

General Information

- Length and tolerance of DC wire varies depending on ordered cable. See Table 4-2.

P/N	Length (Meter)	Tolerance (Meter)
705A030841	2	± 0.1
705A030821	5	± 0.5
705A030851	10	± 0.1
705A030801	50	± 0.5
705A030811	100	± 0.5
705A030831	200	± 0.5

Table 4-2. P/N and Length Table

- DC Input: 25-48 VDC
- No. of DC connector conductors: 8 (all four pairs are connected together – splitting the power evenly between them)
- DC Conductor size: 20 AWG
- At least 8A slow blow fuse

Connection Pinout

Connect the power cable wires according to the wire connection in Table 4-3 and Figure 4-12.

	Wire Color	AWG	PIN
First Couple	Red	20	A
	Black	20	B
Second Couple	Red	20	C
	Black	20	D
Third Couple	Red	20	E
	Black	20	F
Fourth Couple	Red	20	G
	Black	20	H

Table 4-3. Wire Connections

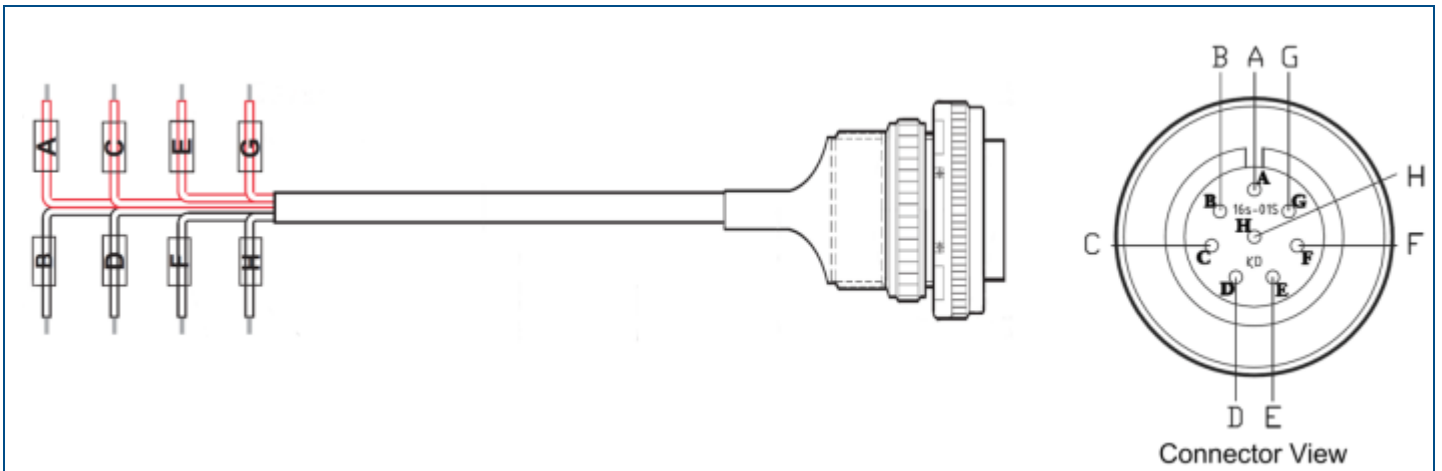

Wiring Diagram | Figure 4-12

4.7 Verify Normal Operation

After the power connections have been completed, verify that the Power LED (located on the underside of the HX unit – see section 1.4.2) is green.

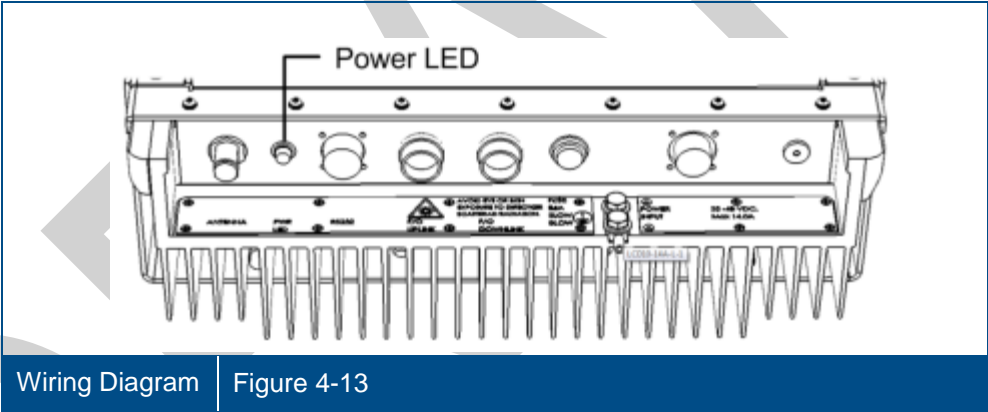

Wiring Diagram | Figure 4-13

Note: The HX monitoring and management capabilities are performed via the host OCH unit. Refer to the SC-450 User Manual for the configuration and management options.

Appendix A: System Specifications

RF Parameters

Supported Services

Technologies	Frequency Range		
	Band	Uplink	Downlink
LTE	700MHz	698-716 and 776-787	728-757
CDMA/LTE	S-800	817-824	862-869
CDMA / WCDMA** / TDMA / GSM	CELL850	824-849	869-894
GSM / GPRS / WCDMA / HSPA / LTE*	EGSM900	880-915	925-960
GSM / GPRS / WCDMA / HSPA / LTE*	DCS1800	1710-1785	1805-1880
CDMA / WCDMA** / TDMA / GSM	PCS1900	1850-1915	1930-1995
WCDMA** / HSPA	AWS2100	1710-1755	2110-2155
WCDMA / HSPA / LTE*	UMTS2100	1920-1980	2110-2170

(*) WCDMA service is based on 3GPP standards, LTE service may be deployed in the future due to frequency re-farming planned by the operators.

(**) WCDMA service is based on 3GPP2 CDMA2000 standards.

RF Parameters per Low-Band Service

HX RF Parameters	LTE 700 MHz		CELL TDMA CDMA/WCDMA 850 MHz		CDMA/LTE S-800 MHz + CELL/TDMA/CDMA/ WCDMA 850 MHz		GSM/ E-GSM 900 MHz	
	DL	UL	DL	UL	DL	UL	DL	UL
Max Output Power Per Antenna Port 1 Operator (Composite)	33		33*		33		29	
2 Operators	30		30		30		26	
4 Operators	27		27		27		23	
8 Operators	-		24		24		20	
Mean Gain (dB) ¹	33	11	33	11	33	11	29	16
Pin (dBm)	0		0				0	
Input IP3 (dBm) AGC OFF Typical		-10		-10		-10		-10
Max Intermod Distortion (dBm)	-13**		-13**		-13**		-36*	
NF (dB) at Max Gain		7		7		7		7
Gain Flatness/Ripple (dB) ²	+/-1.5							
Max. Noise Level	44							

* WCDMA complies with 3GPP TS 25.106 V5.0.0 (2002-03) table 9.4 spectrum emission mask.

** Out of band and spurious emissions compliant to FCC.

¹Factory set mean gain BU-HX without RIU. May be field adjusted using controller system.

²Gain Flatness/Ripple is specified for the non-duplexed port of the system.

RF Parameters per High-Band Service

HX RF Parameters	DCS 1800 MHz		PCS CDMA/WCDMA 1900 MHz		AWS CDMA/WCDMA 2100 MHz		UMTS 2100 MHz	
	DL	UL	DL	UL	DL	UL	DL	UL
Max Output Power Per Antenna Port 1 Operator (Composite)	32		33		33		33	
2 Operators	29		30		30		26	
4 Operators	26		27		27		23	
8 Operators	23		24		24		20	
Mean Gain (dB) ¹	32	16	33	11	33	11	29	16
Pin (dBm)	0		0		0		0	
Input IP3 (dBm) AGC OFF Typical		-10		-10		-10		-10
Max Intermod Distortion (dBm)	-30*		-13*		-13*		13*	
NF (dB) at Max Gain		7		7		7		7
Gain Flatness/Ripple (dB) ²	+/- 2.0							
Max. Noise Level	44							

* WCDMA complies with 3GPP TS 25.106 V5.0.0 (2002-03) table 9.4 spectrum emission mask.

** Out of band and spurious emissions compliant to FCC.

¹ Factory set mean gain BU/OCH-HX without RIU. May be field adjusted using controller system.

² Gain Flatness/Ripple is specified for the non-duplexed port of the system.

Coupling Specifications*

Frequency (MHz)	Coupling (dB)	Frequency (MHz)	Coupling (dB)
700	-48.0	2100	-39.0
800	-47.1	2200	-38.5
900	-46.1	2500	-37.4
1000	-45.0	2600	-37.0
1700	-40.7	2700	-36.7
1800	-40.1		
1900	-39.7		
2000	-40.7		

*Coupling specifications are only relevant to HX models with integrated Test Ports (refer to ordering information section of this Specifications Sheet)

Optical Specifications

Optical Output Power	<3.0 mW
Max. Optical Budget	2 dB for fiber + 1 dB for connectors (assumed) = 3 dB total. 300 m Multi-mode
Optical Loss per Mated-pair Connectors	0.5 dB (max)
Optical Connector	Indoor: SC/APC Outdoor: Corning OptiTap®
Fiber Type	Single-mode: 9/125µm Multi-mode: 50/125 µm or 62.5/125µm (Minimum qualifications with ANSI/TIA/EIA-568-B series, EN50173-1 or ISO/IEC 11801)
Wavelength	1310 ± 10 nm
Maximum Distance Between Base Unit and Remote Cabinet	2 km for SMF 300 m for MMF

Physical Specifications

Indoor Remote Unit

Ports	One SC/APC fiber-optic pair connector or two for MIMO models One N-Type female 50Ω connector for antenna (two connectors for MIMO models) One Power connector (model dependent): <ul style="list-style-type: none">• AC models: One power connector for 90-264VAC power feed• DC models: One 18 pin power connector for 25-48VDC power feeds One D-Type 9 pins RS-232 connector (or two for MIMO models) for local craft Two SMA type Test Port connectors (one UL and one DL) – model dependant
Power	HX Indoor AC: 90-264 VAC; FUSE,250V/8A,5x20mm, slow blow fuse HX Indoor DC: 25-48V DC; 18 pin connector supports 20-30 AWG wires; Max. current (per pin) = 5A Max Power Consumption: 350 W (SISO models), 500 W (MIMO models) Fuses: Includes two internal fuses
Physical Characteristics	Mounting: Wall or Rack Dimensions (H x W x D): 13.8 x 16.9 x 14.9 in (350 x 429 x 378 mm) Weight: Three Services SISO configuration: 66 lbs (30 kg) Four Services SISO configuration: 71 lbs (32 kg) Two SISO and two MIMO services configuration: 92 lbs (42 kg)
Cooling Feature	Active heat dissipation (Fan)

Outdoor Remote Unit

Ports	<ul style="list-style-type: none"> (2) Corning OptiTap® fiber optic waterproof connectors (1 for UL and 1 for DL) (1) N-Type female 50Ω connector for antenna (1) Waterproof power connector – model dependent: <ul style="list-style-type: none"> • AC model: 1-20UNEF, plug, 3-pin waterproof, solder for panel, power connector for 100/240 VAC power feed • DC model: 1-20UNEF, plug, 8-pin waterproof, solder for panel, power connector for 25-48 VDC power feed (1) D-Type 9 pins RS-232 waterproof connector for local craft (2) SMA type Test Port connectors (one UL and one DL) – model dependant
Power	<ul style="list-style-type: none"> • HX Outdoor AC: 100/240 VAC; FUSE,250V/8A,6.35x32 mm, slow blow • HX Outdoor DC: 25-48V DC; FUSE,250V/16A,6.35x32mm, slow blow • Max Power Consumption: 340 W
Physical Characteristics	<p>Mounting: Wall or Pole</p> <p>Dimensions (H x W x D) (mm): 24.2"* x17.5"*x 11.4" (615* x 442 x 285.3)</p> <p>*without 'Brush Ring'</p> <p>Weight (four services configuration): 88 lbs (40 kg)</p>
Cooling Feature	Passive heat dissipation (Heat Sink)

Environmental Specifications

	Indoor Remote Unit	Outdoor Remote Unit
Operating Temperature	0°C to +50°C (32°F to 122°F)	-30°C to +65°C (-22°F to 149°F)
Storage Temperature	-20° to 85°C (-4° to 185°F)	-20° to 85°C (-4° to 185°F)
Humidity	10% to 90%, non-condensing	10% to 90%, non-condensing
Enclosure	-	NEBS OSP Class 4 rated (Enclosure protected from elements and waterproofing)

Standards and Certifications

Laser Safety	<ul style="list-style-type: none"> • CDRH 21 CFR 1040.10, 1040.11 (Except for deviations per notice No.50, July 26, 2001) • IEC 60825-1, Amendment 2 (January 2001) • EN 60825-1
CE	<p>Radio Equipment and Systems:</p> <ul style="list-style-type: none"> • EN 301 502 – for GSM / EGSM Frequency Bands • EN 300 609 – for DCS Frequency Band • EN 301 893 – for WLAN 802.11a EN 301 908 – for UMTS Frequency Band <p>EMC: EN 301 489</p>
FCC	<p>Radio Equipment and Systems:</p> <ul style="list-style-type: none"> • FCC 47 CFR Part 22 – for CELL Frequency Band • FCC 47 CFR Part 24 – for PCS Frequency Band • FCC 47 CFR Part 27 – for 700 LTE and AWS Frequency Bands <p>EMC: FCC 47 CFR Part 15 Subpart B</p>
Safety	<ul style="list-style-type: none"> • EN 60950; UL 60950 • CAN/CSA-C22.2 No.60950

Appendix B: Ordering Information

Note: The information listed below is updated up to the document publishing date. Refer to the HX datasheet for the most updated ordering information.

HX Indoor Remote Units (SISO and MIMO)

Service Supported	Part Number	Description
CELL/PCS/700LTE/AWS SISO Services	HX-C85P19L70A17-AC-A	HX Quad-service Indoor CELL, PCS, AWS and 700 MHz LTE SISO solution supporting local AC power, SMF and MMF
	HX-C85P19L70A17-DC-A	HX Quad-service Indoor CELL, PCS, AWS and 700 MHz LTE SISO solution supporting remote DC power, SMF and MMF
	HX85197017U80-ACAT	HX-Quad-service indoor CELL, PCS, AWS and 700 MHz LTE SISO solution supporting remote DC power, SMF and MMF; Includes test ports; upgradeable to add Sprint's 800 MHz band
	HX85197017U80-DCAT	HX-Quad-service indoor CELL, PCS, AWS and 700 MHz LTE SISO solution supporting local AC power, SMF and MMF; Includes test ports; upgradeable to add Sprint's 800 MHz band
CELL/PCS/700LTE- MIMO/AWS-MIMO	HX-C85P19L70MA17M-AC-A	HX Quad-service Indoor CELL, PCS, AWS MIMO and 700 MHz LTE MIMO solution supporting local AC power, SMF and MMF
	HX-C85P19L70MA17M-DC-A	HX Quad-service Indoor CELL, PCS, AWS MIMO and 700 MHz LTE MIMO solution supporting remote DC power, SMF and MMF
CELL/S-800/ PCS/700LTE/AWS	HX8085197017-AC-AT	HX-5 band Indoor CELL, S-800, PCS, AWS and 700 MHz LTE SISO solution; supporting local AC power; SMF and MMF; Includes test ports
	HX8085197017-DC-AT	HX-5 band Indoor CELL, S-800, PCS, AWS and 700 MHz LTE SISO solution; supporting local DC power; SMF and MMF; Includes test ports
CELL/GSM/DCS/UMTS SISO Services	HX-C85G91D18U21-AC-A	HX Quad-service indoor CELL, GSM Partner, DCS, and UMTS SISO solution supporting local AC power, SMF and MMF
	HX-C85G91D18U21-DC-A	HX Quad-service indoor CELL, GSM Partner, DCS, and UMTS SISO solution supporting remote DC power, SMF and MMF
GSM/DCS/UMTS SISO Services	HX-G90D18U21-AC-A	HX Tri-service Indoor GSM, DCS and UMTS SISO solution supporting local AC power, SMF and MMF
	HX-G90D18U21-DC-A	HX Tri-service Indoor GSM, DCS and UMTS SISO solution supporting remote DC power, SMF and MMF
GSM/DCS/UMTS MIMO Services	HX-G90MD18U21M-AC-A	HX Tri-service Indoor GSM MIMO, DCS and UMTS MIMO solution supporting local AC power, SMF and MMF
	HX-G90MD18U21M-DC-A	HX Tri-service Indoor GSM MIMO, DCS and UMTS MIMO solution supporting remote DC power, SMF and MMF

HX Remote Outdoor Units (SISO services)

Service Supported	Part Number	Description
CELL/PCS/700LTE/AWS	HX-C85P19L70A17-AC-B	HX Quad-service Outdoor CELL, PCS, AWS and 700 MHz LTE solution supporting local AC power, SMF and MMF
	HX-C85P19L70A17-DC-B	HX Quad-service Outdoor CELL, PCS, AWS and 700 MHz LTE solution supporting remote DC power, SMF and MMF
	HX85197017U80-AC-B	HX Quad-service Outdoor CELL, PCS, AWS and 700 MHz LTE solution; supporting local AC power; includes test ports; upgradeable to add Sprint's 800 MHz band; SMF and MMF
	HX85197017U80-DC-B	HX Quad-service Outdoor CELL, PCS, AWS and 700 MHz LTE solution; supporting remote DC power; includes test ports; upgradeable to add Sprint's 800 MHz band; SMF and MMF
CELL/GSM/DCS/UMTS	HX-C85G91D18U21-AC-B	HX Quad-service Outdoor CELL, GSM Partner, DCS and UMTS solution supporting local AC power, SMF and MMF
	HX-C85G91D18U21-DC-B	HX Quad-service Outdoor CELL, GSM Partner, DCS and UMTS solution supporting remote DC power, SMF and MMF
GSM/DCS/UMTS	HX-G90D18U21-AC-B	HX Tri-service Outdoor GSM, DCS and UMTS solution supporting local AC power, SMF and MMF
	HX-G90D18U21-DC-B	HX Tri-service Outdoor GSM, DCS and UMTS solution supporting remote DC power, SMF and MMF
CELL/S-800/PCS/700LTE/AWS	HX8085197017-AC-B	HX-5 band Outdoor CELL, S-800, PCS, 700 MHz LTE and AWS solution supporting local AC power, SMF and MMF
	HX8085197017-DC-B	HX-5 band Outdoor CELL, S-800, PCS, 700 MHz LTE and AWS solution supporting local AC power, SMF and MMF

Accessory Kits

Part Number	Description
AK-HX-SW-4B-2-5B	Accessory kit with HW/SW to upgrade the HX-quad band upgradable units to add Sprint's 800MHz band

Optical Central Hub (OCH) - HX International products

Part Number	Description
OCH-HX-4-MMF	Optical Central Hub for SISO services, supporting (4) SISO HX units, MMF
OCH-HX-4-SMF	Optical Central Hub for SISO services, supporting (4) SISO HX units, SMF
OCH-HX-8-MMF	Optical Central Hub for SISO or MIMO Services, supporting (8) SISO or (4) MIMO HX units, MMF
OCH-HX-8-SMF	Optical Central Hub for SISO or MIMO Services, supporting (8) SISO or (4) MIMO HX units, SMF

Corning OptiTap™ Cables

Part Number	Description
434401EB4R2005M-P	OptiTap® to SC/APC 5 meters
434401EB4R2030M-P	OptiTap® to SC/APC 30 meters
434401EB4R2100M-P	OptiTap® to SC/APC 100 meters

Appendix C: HX Outdoor Non-Standard Connector Descriptions

Table 4-4 provides a description of the HX Outdoor RS-232 and Power (AC or DC) connectors.

Connector	Manufacturer Name	Manufacturer P/N	Description
AC Power	KUKDONG	KD3100A16S-5P-A02	CONN, 1-20UNEF, PLUG,3 PINS ,SOLDER FOR PANNEL,WATERPROOF
DC Power	KUKDONG	KD3100A16S-01P-A02	CONN, 1-20UNEF, PLUG,8 PINS ,SOLDER FOR PANNEL,WATERPROOF
RS232 <i>Note: Used for local setup and maintenance by technical personnel</i>	KUKDONG	KD3100A14SA10P-A02	CONN, 7/8-20UNEF,PLUG,10 PINS ,SOLDER FOR PANNEL,WATERPROOF

Table 4-4. Non-Standard Connectors Descriptions

Appendix D: Power Cable Specifications

AC Power Cable Specifications

Use the following cable: TELDOR, Manufacturer P/N 3318300101 (or equivalent).

Conductor Material:	Bare Copper
Conductor Size:	18 AWG
Conductor Construction:	42 x 0.16 mm
Insulation Material:	PVC
Insulation Thickness:	0.6 mm
Insulation O.D.:	2.4 mm nom.
Conductor Color Code:	Brown, Blue, Yellow/Green
Total Number of Elements:	3
Outer Jacket Thickness:	0.9 mm nom.
Outer Jacket Color:	Black
Marking:	Teldor Standard

DC Power Cable Specifications

Use the following cable: TELDOR, Manufacturer P/N 3320800101 (or equivalent).

Conductor Material:	Bare Copper
Conductor Size:	20 AWG
Conductor Construction:	19 x 0.20 mm
Insulation Material:	FR-PVC
Insulation O.D.:	2.0 mm nom.
Conductor Color Code:	4 Black; 4 Red
Outer Jacket Thickness:	0.9 mm nom.
Outer Jacket Color:	Black

DRAFT

**CORNING OPTICAL COMMUNICATIONS WIRELESS LTD. 13221 WOODLAND PARK RD, SUITE 400, SUITE 400 • HERNDON, VA 20171 USA
866-436-9266 • FAX: 703-848-0280 • TECH SUPPORT HOTLINE: 410-553-2086 OR 800-787-1266 • WWW.CORNING.COM/SITES/OPCOMM**

CORNING OPTICAL COMMUNICATIONS RESERVES THE RIGHT TO IMPROVE, ENHANCE AND MODIFY THE FEATURES AND SPECIFICATIONS OF CORNING OPTICAL COMMUNICATIONS PRODUCTS WITHOUT PRIOR NOTIFICATION. OPTITAP® IS A REGISTERED TRADEMARK OF CORNING CABLE SYSTEMS BRANDS, INC. ALL OTHER TRADEMARKS ARE THE PROPERTIES OF THEIR RESPECTIVE OWNERS. CORNING OPTICAL COMMUNICATIONS IS ISO 9001 CERTIFIED. © 2013 CORNING OPTICAL COMMUNICATIONS. ALL RIGHTS RESERVED.

PUBLISHED IN THE USA. CMA-066-AEN

UM_HX_709C006802 Rev A00_24JULY2014