

Corning

MobileAccess

MobileAccessGX™ QUAD DAS System

User Manual

Warranties

Hardware

Corning MobileAccess warrants to the original purchaser (“Customer”) that for the duration of the warranty period, one (1) year, commencing on the date of shipment of the Hardware, unless otherwise agreed in writing by Corning MobileAccess (the “Hardware Warranty Period”), the Hardware furnished by Corning MobileAccess shall be free in all material respects from defects in material and workmanship, and shall conform to the applicable portions of the Specifications, as defined below (the “Hardware Warranty”).

If notified by Customer of any such defects in material or workmanship or nonconformity with applicable portions of the Specifications within the Hardware Warranty Period, Corning MobileAccess shall promptly, at its own election and expense, repair or replace any such Hardware proven to be defective under the terms of this Hardware Warranty.

Such repair or replacement shall be Customer’s sole remedy and Corning MobileAccess’ sole obligation in the event this Hardware Warranty is invoked. If any components comprising a part of the Hardware are replaced or repaired during the Hardware Warranty Period, the Hardware Warranty Period for such repaired or replaced components shall extend to the longer of (i) the balance of the Hardware Warranty Period or (ii) three (3) months from the date of repair or replacement. For purposes of this Warranty, “Specifications” shall mean the specifications and performance standards of the Products as set forth in documents published by Corning MobileAccess and delivered to Customer which contain technical specifications or performance standards for the Products.

If Customer invokes this Hardware Warranty, it shall notify Corning MobileAccess promptly of the claimed defect. Customer will allow Corning MobileAccess to inspect the Hardware at Customer’s location, or to return the Hardware to Corning MobileAccess’ closest repair facility. For Hardware returned to Corning MobileAccess’ repair facility, Customer shall be responsible for payment of all transportation and freight costs (including insurance) to Corning MobileAccess’ repair facility, and Corning MobileAccess shall be responsible for all transportation and freight costs (including insurance) incurred in connection with the shipment of such Hardware to other repair facilities of Corning MobileAccess and/or its return to Customer.

Notwithstanding the foregoing, in no event will Corning MobileAccess be liable for damage to Products resulting

from improper handling during or after shipment, misuse, neglect, improper installation, operation or repair (other than by authorized Corning MobileAccess personnel), alteration, accident, or for any other cause not attributable to defects in materials or workmanship on the part of Corning MobileAccess. Corning MobileAccess shall not reimburse or make any allowance to Customer for any labor charges incurred by Customer for replacement or repair of any goods unless such charges are authorized in advance in writing by Corning MobileAccess.

Software Warranty

Corning MobileAccess warrants to the original purchaser (“Customer”) that for the duration of the warranty period, one (1) year, commencing on the date of shipment of the Software, unless otherwise agreed in writing by Corning MobileAccess (the “Software Warranty Period”), the Software shall conform with, and perform the functions set forth in the Specifications, and shall be free from defects in material or workmanship (the “Software Warranty”). In the event the Software is proven to be defective under the terms of this Software Warranty, Corning MobileAccess shall correct such defects or failure and ensure that the Software conforms with, and performs the functions set forth in, the Specifications. Customer will allow Corning MobileAccess to inspect the Software at Customer’s location or to return it to Corning MobileAccess’ closest repair facility.

Notwithstanding the foregoing, Corning MobileAccess shall have no obligation under the Software Warranty if the Software is modified or used with hardware or software not supplied or approved by Corning MobileAccess or if the Software is subject to abuse, improper installation or application, accident, electrical or environmental over-stress, negligence in use, storage, transportation or handling.

Third-party software distributed with the Software may carry certain warranties which, to the maximum extent allowed by law, Corning MobileAccess hereby assigns, transfers and otherwise conveys to Customer, provided, however, that Corning MobileAccess itself provides no warranty of any kind, express, implied, statutory or otherwise, for any third-party software provided hereunder.

Corning MobileAccess does not warrant any hardware, software or services not provided by Corning MobileAccess.

THIS WARRANTY IS THE ONLY WARRANTY MADE BY CORNING MOBILEACCESS AND IS IN LIEU OF ALL OTHER WARRANTIES, EXPRESS OR IMPLIED INCLUDING, BUT NOT LIMITED TO, THE IMPLIED WARRANTIES OF MERCHANTABILITY AND FITNESS FOR A PARTICULAR PURPOSE. CORNING MOBILEACCESS SHALL NOT BE LIABLE FOR ANY OTHER DAMAGE INCLUDING, BUT NOT LIMITED TO, INDIRECT, SPECIAL OR CONSEQUENTIAL DAMAGES ARISING OUT OF OR IN CONNECTION WITH FURNISHING OF GOODS, PARTS AND SERVICE HEREUNDER, OR THE PERFORMANCE, USE OF, OR INABILITY TO USE THE GOODS, PARTS AND SERVICE. CORNING MOBILEACCESS SALES AGENTS OR REPRESENTATIVES ARE NOT AUTHORIZED TO MAKE COMMITMENTS ON WARRANTY RETURNS.

Returns

In the event that it is necessary to return any product against above warranty, the following procedure shall be followed:

1. Return authorization is to be received from Corning MobileAccess prior to returning any unit. Advise Corning MobileAccess of the model, Serial number, and discrepancy. The unit may then be forwarded to Corning MobileAccess, transportation prepaid. Devices returned collect or without authorization may not be accepted.
2. Prior to repair, Corning MobileAccess will advise the customer of our test results and any charges for repairing customer-caused problems or out-of-warranty conditions etc.
3. Repaired products are warranted for the balance of the original warranty period, or at least 90 days from date of shipment.

Limitations of Liabilities

Corning MobileAccess's liability on any claim, of any kind, including negligence for any loss or damage arising from, connected with, or resulting from the purchase order, contract, quotation, or from the performance or breach thereof, or from the design, manufacture, sale, delivery, installation, inspection, operation or use of any equipment covered by or furnished under this contact, shall in no case exceed the purchase price of the device which gives rise to the claim.

Except as expressly provided herein, Corning MobileAccess makes no warranty, expressed or implied, with respect to any goods, parts and services provided in connection with this agreement including, but not limited to, the implied warranties of merchantability and fitness for a particular purpose. Corning MobileAccess shall not be liable for any other damage including, but not limited to, indirect, special or consequential damages arising out of or in connection with furnishing of goods, parts and service hereunder, or the performance, use of, or inability to use the goods, parts and service.

Reporting Defects

The units were inspected before shipment and found to be free of mechanical and electrical defects. Examine the units for any damage that may have been caused in transit. If damage is discovered, file a claim with the freight carrier immediately. Notify Corning MobileAccess as soon as possible in writing.

Note: Keep all packing material until you have completed the inspection

Warnings and Admonishments

There may be situations, particularly for workplace environments near high-powered RF sources, where recommended limits for safe exposure of human beings to RF energy could be exceeded. In such cases, restrictive measures or actions may be necessary to ensure the safe use of RF energy.

The equipment has been designed and constructed to prevent, as far as reasonably, practicable danger. Any work activity on or near equipment involving installation, operation or maintenance must be, as far as reasonably, free from danger.

Where there is a risk of damage to electrical systems involving adverse weather, extreme temperatures, wet, corrosive or dirty conditions, flammable or explosive atmospheres, the system must be suitably installed to prevent danger.

Equipment provided for the purpose of protecting individuals from electrical risk must be suitable for the purpose and properly maintained and used. This covers a range of activities including lifting, lowering, pushing, pulling, carrying, moving, holding or restraining an object, animal or person from the equipment. It also covers activities that require the use of force or effort, such as pulling a lever, or operating power tools.

Where some of the abovementioned activities are required, the equipment must be handled with care to avoid being damaged.

Observe standard precautions for handling ESD-sensitive devices. Assume that all solid-state electronic devices are ESD-sensitive. Ensure the use of a grounded wrist strap or equivalent while working with ESD-sensitive devices. Transport, store, and handle ESD-sensitive devices in static-safe environments.

Note: The grantee is not responsible for any changes or modifications not expressly approved by the party responsible for compliance. Such modifications could void the user's authority to operate the equipment.

This device complies with Part 15 of the FCC Rules. Operation is subject to the following two conditions: (1) this device may not cause harmful interference, and (2) this device must accept any interference received, including interference that may cause undesired operation

WARNING! This is **NOT** a **CONSUMER** device. It is designed for installation by **FCC LICENSEES** and **QUALIFIED INSTALLERS**. You **MUST** have and **FCC LICENSE** or express consent of an FCC License to operate this device. Unauthorized use may result in significant forfeiture penalties, including penalties in excess of \$100,000 for each continuing violation.

Under Industry Canada regulations, this radio transmitter may only operate using an antenna of a type and maximum (or lesser) gain approved for the transmitter by Industry Canada. To reduce potential radio interference to other users, the antenna type and its gain should be so chosen that the equivalent isotropically radiated power (e.i.r.p.) is not more than that necessary for successful communication.

Conformément à la réglementation d'Industrie Canada, le présent émetteur radio peut fonctionner avec une antenne d'un type et d'un gain maximal (ou inférieur) approuvé pour l'émetteur par Industrie Canada. Dans le but de réduire les risques de brouillage radio électrique à l'intention des autres utilisateurs, il faut choisir le type d'antenne et son gain de sorte que la puissance isotrope rayonnée équivalente (p.i.r.e.) ne dépasse pas l'intensité nécessaire à l'établissement d'une communication satisfaisante.

RF Safety

NOTE: Keep all packing material until you have completed the inspection

WARNING! To comply with FCC RF exposure compliance requirements, each individual antenna used for this transmitter must be installed to provide a separation distance greater than 160 cm or more from all persons during normal operation and must not be co-located with any other antenna for meeting RF exposure requirements. The design of the antenna installation needs to be implemented in such a way so as to ensure RF radiation safety levels and non-environmental pollution during operation.

WARNING! Antenna gain should not exceed 12.5 dBi.

WARNING! The design of the antenna installation needs to be implemented in such a way so as to ensure RF radiation safety levels and non-environmental pollution during operation.

Compliance with RF safety requirements:

- Corning MobileAccess products have no inherent significant RF radiation.
- The RF level on the downlink is very low at the downlink ports. Therefore, there is no dangerous RF radiation when the antenna is not connected.

Laser Safety

Fiber optic ports of the MobileAccessGX system emit invisible laser radiation at the 1310/1550 nm wavelength window.

The laser apertures /outputs are the green SC/APC Bulkhead adapters located on the front panel of the equipment. The product is Class 1/Hazard level 1

External optical power is less than 10 mW, Internal optical power is less than 500 mW.

To avoid eye injury never look directly into the optical ports, patchcords or optical cables. Do not stare into beam or view directly with optical instruments. Always assume that optical outputs are on.

Only technicians familiar with fiber optic safety practices and procedures should perform optical fiber connections and disconnections of MobileAccessGX devices and the associated cables.

MobileAccessGX has been tested and certified as a Class 1 Laser product to IEC/EN 60825-1 (2007). It also meets the requirements for a Hazard Level 1 laser product to IEC/EN 60825-2: 2004 to the same degree.

MobileAccessGX complies with 21 CFR 1040.10 and 1040.11 except for deviations pursuant to Laser Notice NO. 50 (2007).

MobileAccessGX employs a Class 3B laser and therefore the following label is affixed inside the unit adjacent to the laser:

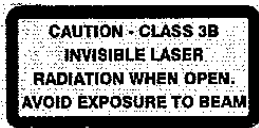

The product itself has been tested and certified as a Class 1 Laser product to IEC/EN 60825-1 (2007). It also meets the requirements for a Hazard Level 1 laser product to IEC/EN 60825-2: 2004 to the same degree.

Care of Fiber Optic Connectors

Do not remove the protective covers on the fiber optic connectors until a connection is ready to be made. Do not leave connectors uncovered when not connected.

The tip of the fiber optic connector should not come into contact with any object or dust.

Refer to the cleaning procedure for information on the cleaning of the fiber tip.

Standards and Certifications

Corning MobileAccess products have met the approvals of the following certifying organizations:

| Category | Standards |
|----------|---|
| Safety: | CB: IEC 60950; NRTL: UL 60950; CAN/CSA: C22.2 NO 60950 |
| EMC: | ETSI: EN 301489; FCC: Part 15 subpart B |
| Radio: | ETSI: EN 301908; EN 301502; EN 300609 FCC: Part 22, 24, 27 |
| ISO: | ISO 9001: 2000 and ISO 13485: 2003 |

About this Guide

This Installation Guide describes how to perform the physical installation of the MobileAccessGX unit. The installation procedures of other units (e.g. RIU, OCH-GX, SC-450) relevant to the system are detailed in their user manuals (see *Additional Relevant Documentation* below).

Additional Relevant Documents

The following documents are required if the corresponding units are included in your system.

| Document Name |
|--|
| RIU Installation and Configuration Guide |
| FT350 Installation Guide (includes OCH-GX information) |
| System Controller User Manual (SC-450 v5.4 and higher) |
| MA Software Version Update Tool |

List of Acronyms

| | |
|---------------|--------------------------------------|
| BDA | Bi-Directional Amplifier |
| BTS | Base Transceiver Station |
| BTSC | Base Transceiver Station Conditioner |
| BU | Base Unit |
| DL | Downlink |
| OCH-GX | (Dedicated GX) Optical Central Hub |
| RU | Remote (Hub)Unit |
| RIU | Radio Interface Unit |
| UL | Uplink |

Table of Contents

- Warranties2**
- Hardware2
- Software Warranty3
- Returns3
- Limitations of Liabilities4
- Reporting Defects4
- Warnings and Admonishments.....4**
- RF Safety6**
- Compliance with RF safety requirements:6
- Laser Safety7**
- Care of Fiber Optic Connectors7
- Standards and Certifications8**
- About this Guide8**
- List of Acronyms.....9**
- Table of Contents.....10**
- 1 Introduction12**
- 1.1 Key Features and Capabilities13
- 1.2 System Architecture13
 - 1.2.1 Signal Path.....15
- 1.3 System Monitoring and Management.....15
- 1.4 GX-Quad Unit Interfaces17
- 2 Installation Guidelines19**
- 2.1 Site Considerations19
 - 2.1.1 Installation Location19
 - 2.1.2 Environmental19
 - 2.1.3 Powering19
 - 2.1.4 Grounding Requirement.....19
 - 2.1.5 Cable Routing20
 - 2.1.6 Manual Handling20
- 2.2 Installation Requirements20
- 2.3 Fiber Optic Rules21

| | | |
|----------|--|-----------|
| 3 | System Installation | 22 |
| 3.1 | Installing External Filter (If Required)..... | 22 |
| 3.2 | Installing External Combiner | 23 |
| 3.3 | Installing the GX Unit | 25 |
| 3.3.1 | Unpacking and Inspection | 25 |
| 3.3.2 | Required Tools | 26 |
| 3.3.3 | Mounting | 27 |
| 3.3.3.1 | Wall Mount Installation | 27 |
| 3.3.3.2 | Pole Mount Installation | 31 |
| 3.4 | GX Connections | 33 |
| 3.4.1 | Grounding Connections..... | 33 |
| 3.4.2 | F/O Connections..... | 34 |
| 3.4.3 | RF Connections | 35 |
| 3.4.4 | Power Connections | 36 |
| 3.4.5 | External Alarm Connections..... | 37 |
| 3.4.6 | System Alarm Pin-Out Description | 37 |
| 3.5 | Verifying Normal Operation | 38 |
| | Appendix A: System Specifications | 39 |
| | RF Parameters | 39 |
| | Supported Services | 39 |
| | RF Parameters per Service | 40 |
| | Optical Specifications | 41 |
| | Physical Specifications..... | 41 |
| | Environmental Specifications | 41 |
| | Appendix B: Ordering Information | 42 |

1 Introduction

MobileAccessGX-Quad offers a cost-effective 40 W (46 dBm) high power remote outdoor coverage solution for Corning MobileAccess Distributed Antenna Systems (DAS).

MobileAccessGX-Quad is a fiber-fed, multi-frequency, multi-operator remote designed to complement the MobileAccess1000 and MobileAccess2000 lower power, standard remotes. GX can also be installed as a dedicated solution for new sites, providing complete RF coverage options for open indoor, tunnel and adjacent outdoor spaces.

Using low loss fiber optic cabling, GX-Quad remote units can distribute multiple BTS signal sources for CELL/PCS/700LTE or AWS to multiple remote locations between 2 to 15 km from the head end to remotes. GX efficiently supports all operator modulations with linear MCPA (multi-carrier power amplifier) up to 40 W.

MobileAccessGX-Quad remotes share a common equipment head end and Element Management System (EMS) with other remotes on the MobileAccess1000/2000 platform.

GX-Quad remotes offer high RF power coverage capabilities with compact design for added spaces savings and weather resistant enclosures to fit various site needs.



1.1 Key Features and Capabilities

- **Multi-Frequency/Multi-Service RF Transport Platform:** Accommodates GSM, UMTS, HSPA, LTE, EDGE, EV-DO, and more. Three model-dependent bands per enclosure.
- **Cost-Effective Higher Power:** Optimizes and reduces the number of antennas required to cover open and outdoor areas by offering 46dBm (GX-40 W) composite power per frequency band.
- **Operator-Grade Operation:** Advanced signal handling and management ensures operator-grade performance.
- **Unique, space-saving non-obtrusive design:** Blends into the environment and avoids costly tower builds outdoors when covering campus scenarios, parking lots, tunnels and indoor-adjacent outdoor space.
- **Designed to withstand harsh environments -** Fully sealed Remote Unit (RU) enclosure ensures superior performance in harsh environments and worry-free electronics maintenance. Compliant to IP65/NEMA standard.
- **Management and control** – alarm forward to NOC or standard EMS via SNMP, software controlled output power and Optical link auto gain control

1.2 System Architecture

MobileAccessGX-Quad provides a complete solution consisting of GX-Quad remote units at the remote locations, and head end elements, which are shared with any existing or new MA1000/MA2000 deployment.

MobileAccessGX-Quad Remote Unit consists of a uniquely designed, non-obtrusive unit that includes all of the required RF, F/O and power interfaces. All mobile services are distributed through service/band dedicated RF connection ports over antennas installed at the remote locations.

The following figure illustrates a scenario in which MobileAccessGX-Quad is installed alongside MobileAccess2000 remotes and MobileAccessHX remotes. Note that all site elements are managed and controlled via a single SC-450 Controller. All site elements (in this scenario example), are controlled and managed by the SC-450 Controller that enables local and remote management, and provides single-source, centralized 'common head end' controls of MA1000, MA2000, HX and GX-Quad elements.

In the downlink, at the head end, the BTS or BDA signal is conditioned by the RIU, ensuring a constant RF level. The conditioned signal is then converted by the OCH-GX (GX Optical Central Hub) to an optical signal for transport over single mode to the GX remote units, which are located at the remote locations. In the uplink, the process is reversed. The SC-450 Controller enables local and remote management, as well as controls all GX-Quad, MA1000 and MA2000 elements from a single, centralized location.

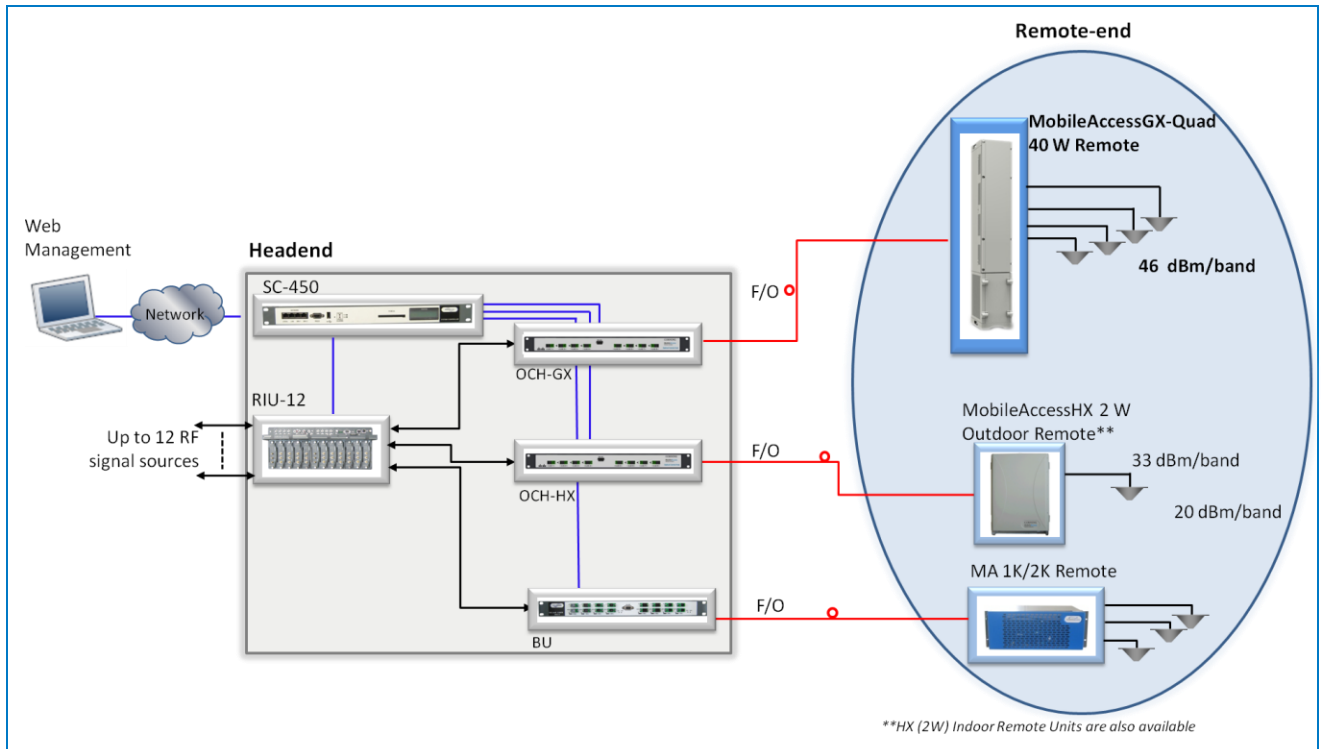

GX Architecture Diagram

Figure 1-2

NOTE: When MobileAccessGX-Quad unit is deployed with units supporting the 800MHz band, an external filter is needed to be installed on the GX-Quad to avoid the disturbance between the 800MHz DL and the 850MHz UL frequencies.

1.2.1 Signal Path

On the DL, combined RF signals (from up to four supported services) from the Radio Interface Unit (RIU) are converted into optical signals by the Optical Control Hub (OCH). The optical signals are then transmitted to the GX at the remote site via optical fiber. The signals are filtered and amplified at the GX and transmitted through the service specific output ports to the broadband antennas.

On the UL, GX converts the RF signals transmitted from the service antennas into optical signals. The signals are transmitted via optical fiber to the OCH-GX which then converts the optical signals back to RF signals.

The optical DL and UL signal are transmitted in a single optical fiber based on the WDM technology.

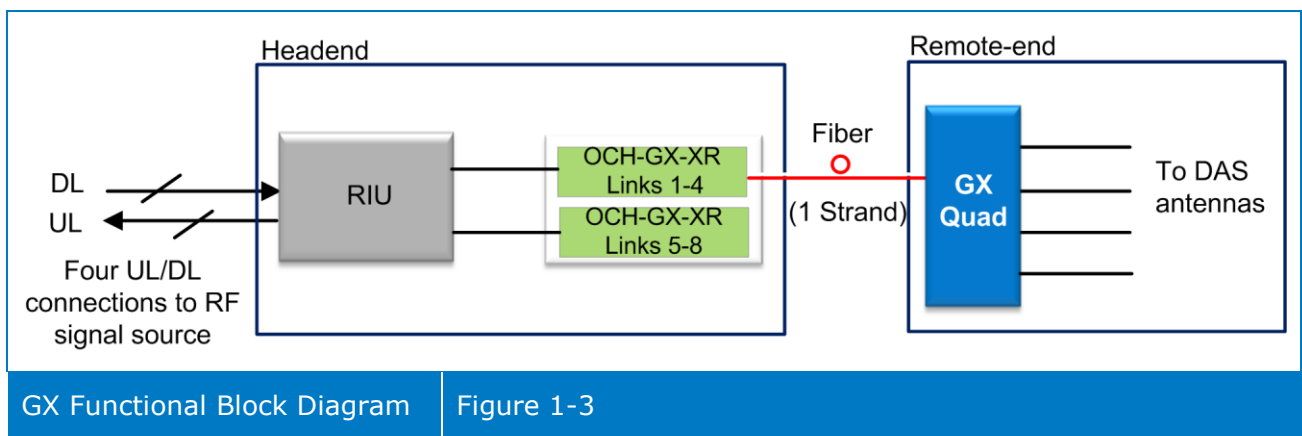

1.3 System Monitoring and Management

The MobileAccess**GX-Quad** Remote Unit is centrally managed via the MobileAccess SC-450 Controller.

NOTE: The GX-Quad solution is supported by SC-450 v5.4 and higher.

MobileAccess**GX-Quad** is not connected directly to the controller; it is connected to the OCH-GX element (that is connected to the controller). Thus, the controller monitors views and manages the GX-Quad via the OCH-GX, hosting the GX unit.

The following shows the Config(uration) tab of the selected GX unit. The system configuration and management is described in the SC-450 UM (v5.4 and higher).

CORNING | MobileAccess
Wireless Solutions

Monitor | Config | Events | Setup | Management | Help | Log Out

SC-450

- CNTRL-M
- P1-RIU-4
 - P1-BDAC -CELL1
 - P2-BTSC -AWS
 - P3-BTSC -LTE1
 - P4-BTSC -PCS1
- P4-OCH UNIT
 - OCH 1-4 -OPTM1
 - OCH 5-8 -OPTM2
 - GX5 -new quad
 - GX8 | GX | oTy

Add New Device Add

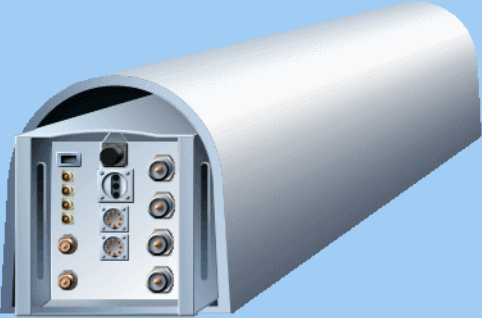

GX Alarms

- Door Open ✓
- Optical Link ✓
- Fans ✓
- Over Temperature ✓
- Service 1-LTE700F ✓
- Service 2-CELL850F ✓
- Service 3-PCS1900F ✓
- Service 4-AWS2100F ✓

Overall Status ● Modify

Module Info | RF Parameters | DL Adjustment | Service Alarms | Ext.Alarms

Name: Modify

| | | | |
|----------------|-------------|-------------------------|--|
| Type | 46 dBm/40 W | Serial Number | 7D05301 |
| Service 1: | LTE700F | Site ID: | <input type="text" value="7D053010-FF"/> Modify |
| Service 2: | CELL850F | Firmware Ver. | 8.9 |
| Service 3: | PCS1900F | Product Revision | B.00 |
| Service 4: | AWS2100F | Laser And Optics | |
| Location Index | 0/4/2/1 | Link Status | NORMAL |
| | | Link Level | 104 |

Example of GX Configuration Tab

Figure 1-4

CORNING | MobileAccess
Wireless Solutions

Introduction | P/N 709C010701 | Page 16

1.4 GX-Quad Unit Interfaces

All of the GX interfaces (except for the power connector) are located externally on the underside of the unit (facing down when unit is mounted). The unit interfaces include the RF, power, optical link and external alarms connections.

The power connector is located in a separate side panel.

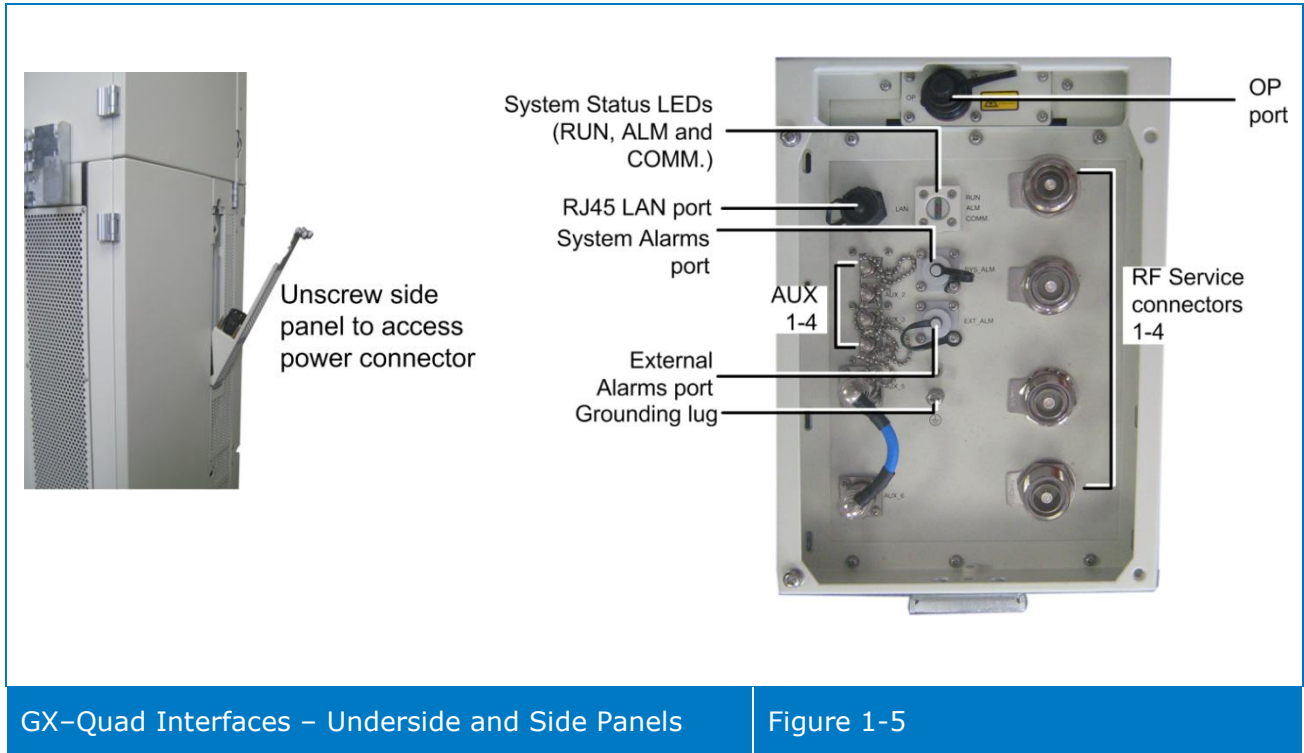

GX-Quad Interfaces – Underside and Side Panels

Figure 1-5

Table 1-1 and Table 1-2 provide descriptions of the GX-Quad connectors and LEDs.

| Interface | Description |
|--|--|
| Service Connectors (e.g. 850MHz, 700MHz, LTE, AWS) | DIN female connectors to antennas (or external combiner – see section 3.2) |
| OP | Corning OptiTap™ Fiber-optic waterproof connector to OCH-GX-XR for either SM or MM fibers. |
| Power Connector (side panel) | Remote Power (AC) Power feed options: 100-240V 47-63 Hz Max Power Consumption: 1600W |
| LAN | RJ45 connector for local connection (i.e. debugging, troubleshooting) |
| EXT_ALM | External Alarm pin-out connectors supporting four external alarm connections |
| SYS_ALM | Pin-out connector supporting up to 3 relay alarms used for connecting the GX-QUAD to a network or modem and relaying the status of the GX alarms |
| AUX_1 | Coupler port - 1900MHz 50dB coupling |
| AUX_2 | Coupler port - AWS 50dB coupling |
| AUX_3 | Coupler port - 850MHz 50dB coupling |
| AUX_4 | Coupler port - 700MHz 50dB coupling |
| FILTER_ OUT/ FILTER_ IN* | Connections to external filter – only relevant if External Filter (ordered separately) is installed on GX-Quad |

Table 1-1. Connector Descriptions

| LED | Description |
|-------|--|
| RUN | GREEN – Power on |
| ALM | OFF – Normal operation RED - Fault |
| COMM. | BLINKING GREEN - Flashes (rate of flash per second) for the duration of 1 minute upon communication initialization RAPID/NO FLASH - Indicates communication fault |

Table 1-2. LED Descriptions

2 Installation Guidelines

This chapter provides the general guidelines for installing the MobileAccessGX-Quad Remote Unit and includes information such as site considerations and installation requirements.

2.1 Site Considerations

- The distance between the GX-Quad service antenna and the coverage area should correspond to LOS (Line of Sight) requirements for maximum coverage area.
- The maximum fiber path loss is 6dB.
- The system delay of the optical system must be taken into consideration when there are neighboring BTS sites overlapping in coverage.
- When the GX-Quad remote unit is deployed with units supporting the 800MHz band, an external filter is needed to be installed on the GX-Quad to avoid the disturbance between the 800MHz DL and the 850MHz UL frequencies. See section 3.1.
- In the MIMO scenario, two remote units shall use a pair of optic fiber for each one. This ensures to avoid the system delay difference between two units.

2.1.1 Installation Location

Mounting surface shall be capable of supporting the weight of the equipment.

In order to avoid electromagnetic interference, a proper mounting location must be selected to minimize interference from electromagnetic sources such as large electrical equipment.

2.1.2 Environmental

Humidity has an adverse effect on the reliability of the equipment. It is recommended to install the equipment in locations having stable temperature and unrestricted air-flow.

The installation location for the system should be well ventilated. The equipment has been designed to operate at the temperature range and humidity level as stated in the product specifications at temperatures ranging from $-40\sim 70^{\circ}\text{C}$ and a relative humidity of max. 95%.

2.1.3 Powering

The power supply unit (PSU) provides power to all modules within the equipment. Depending on the product variant, it is recommended that the PSU operates on a dedicated AC circuit breaker or fused circuit.

2.1.4 Grounding Requirement

Verify that the equipment has been well grounded. This includes GX unit, external combiner, antennas and all cables connected to the system. Ensure lightning protection for the antennas is properly grounded.

2.1.5 Cable Routing

Ensure all cables, e.g. power cable, feeder cable, optic fiber, commissioning cable, connecting are properly routed (use drip-loops) and secured so that they are not damaged.

2.1.6 Manual Handling

During transportation and installation, take necessary handling precautions to avoid potential physical injury to the installation personnel and the equipment.

2.2 Installation Requirements

- Working space available for installation and maintenance for each mounting arrangement. Ensure unrestricted airflow.
- Ensure grounding connector is within reach of the ground wire.
- Ensure a power source is within reach of the power cord and the power source has sufficient capacity.
- Where appropriate, ensure unused RF connectors are terminated.
- Do not locate the equipment near large transformers or motors that may cause electromagnetic interference.
- Reduce signal loss in feeder cable by minimizing the length and number of RF connections.
- Ensure the equipment will be operated within the stated environment (refer to datasheet).
- Where appropriate, confirm availability of suitably terminated grade of RF and optical fiber.
- Observe handling of all cables to prevent damage.

2.3 Fiber Optic Rules

ATTENTION!

Please also refer to the Laser Safety section in the document Preface.

- Fiber optic cables require proper handling. Do not stretch, puncture, or crush the fiber cable(s) with staples, heavy equipment, doors, etc.
- Always maintain the minimum bending radius specified by the cable manufacturer. The minimum bend radius is usually 10 times the cable's outer diameter. In the case of single optical fiber that is not in a cable, the minimum bending radius to be observed is 30mm.
- WDM, Wave Division Multiplexing, units require SMF
- Use minimum splicing/connectors to achieve minimum losses on the fibers.
- Use precaution while installing, bending, or connecting fiber optic cables.
- Use an optical power meter and OTDR for checking the fiber optic cables.
- Make sure the environment is clean while connecting/splicing fiber optic cables.
- All fiber optic connections should be cleaned prior to attaching to termination points using a dry cleaning device (i.e. Cletop or equivalent).
- Fiber connector protective caps should be installed on all non-terminated fibers and removed just before they are terminated.
- Check the Fiber Optic connections.

3 System Installation

This chapter describes the installation procedure for the MobileAccessGX-Quad Remote Units. The installation of the system components must be in the following order:

1. External Filter installation - only relevant for GX-Quad models supporting CELL band and which are deployed with units supporting 800 MHz band. See section 3.1.
2. External Combiner installation (optional). See section 3.2.
3. GX-Quad Installation. See section 3.3.

3.1 Installing External Filter (If Required)

An external filter is required if GX-Quad remote unit supporting the CELL band is deployed along with units supporting the 800MHz band.

NOTE: The External Filter is not supplied with the GX unit and must be ordered separately.

1. Mount the External Filter on the side of the GX-Quad remote unit using the filter bracket so that the Input and Output connectors face the direction of the GX-Quad panel connectors.
2. Remove the jumper cable from the GX-Quad filter In/Out connectors and connect to corresponding External Filter connections.

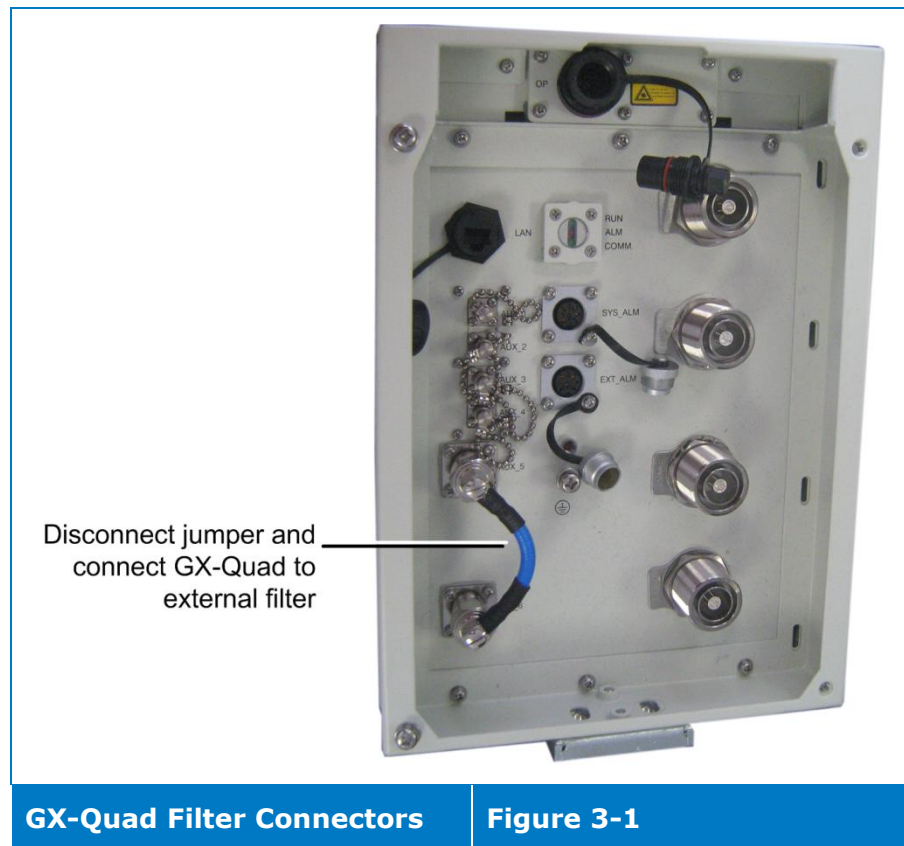

3.2 Installing External Combiner

NOTE: The external combiner is ordered separately and supports up to 4 service inputs. The GX remote unit supports 3 services, requiring that the unused combiner input be terminated.

The 4x1 external combiner (AK-GX-FILT-COMB) combines the input signals of the four GX supported bands (e.g. CELL, PCS, LTE700 and AWS) and transmits them through a single output port to the broadband service antenna.

The external combiner kit includes the following items:

| Item | Description | QTY. |
|--|--|------|
| External Combiner (Multiplexer and arrestor) | 4 x 1 service specific combiner | 1 |
| DIN-M to DIN-M cable 1.5 m | Used to connect the GX RF service ports to the external combiner input ports | 4 |
| DIN-M terminator | Used to terminate remaining unused input port (GX support only 3 services) | 1 |

The external combiner is pre-assembled with a wall mount bracket and must be mounted adjacent to the GX mounting location using the appropriate bolts (not provided).

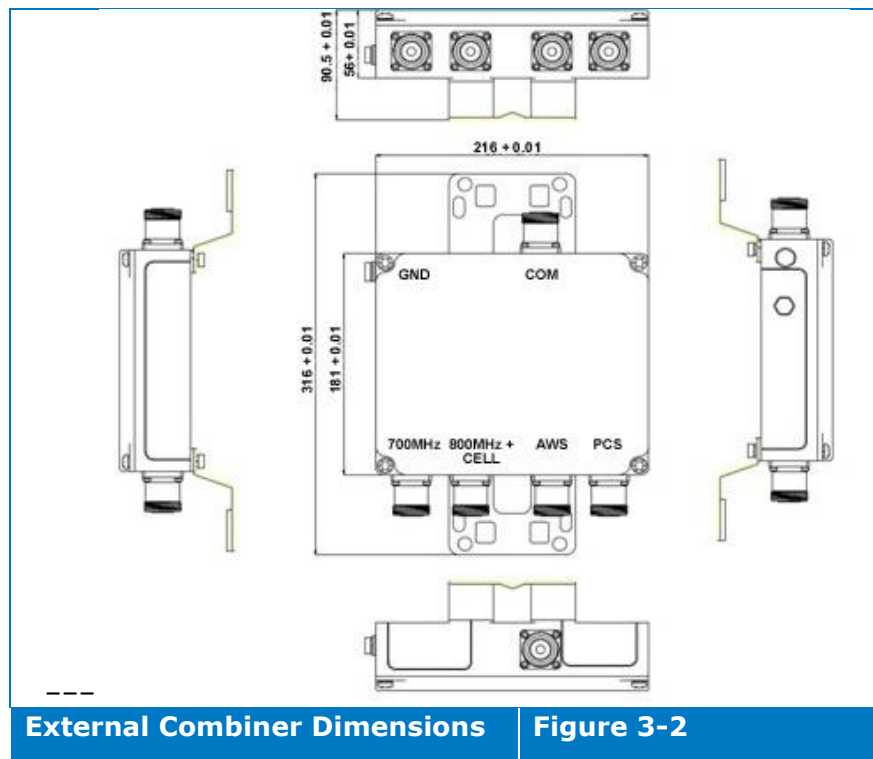

Mount the external combiner with the service specific input ports facing downwards.

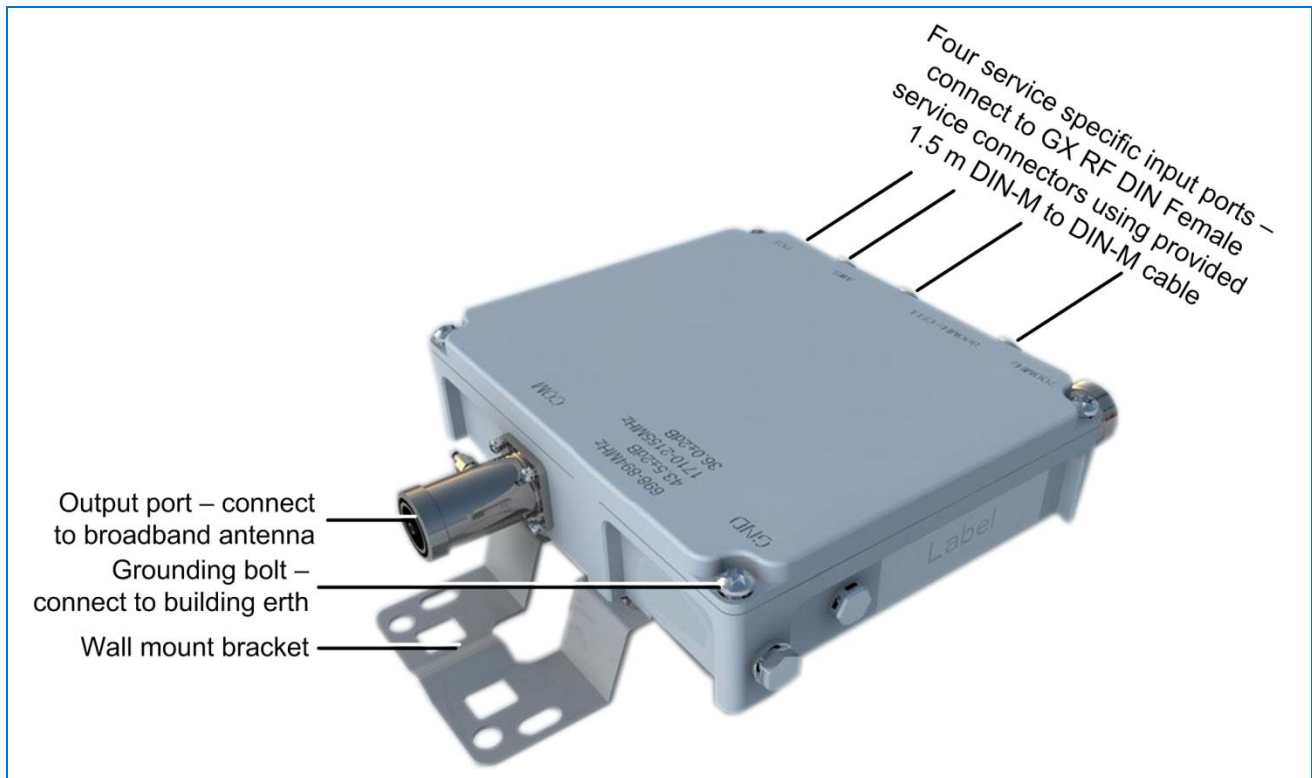

External Combiner Interfaces

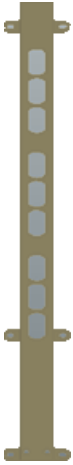



Figure 3-3





3.3 Installing the GX Unit

3.3.1 Unpacking and Inspection

Unpack and inspect the cartons according to the following procedure

1. Open the shipping carton and carefully unpack each unit from the protective packing material.
2. Please verify that the items listed below are included in your package (image size is not proportional):

| Item | Qty. | Image |
|--|---------------|---|
| MobileAccessGX-Quad Remote Unit | 1 |  |
| Mounting Bracket (used for both pole and wall installations) | 1 |  |
| Nuts M8, Spring Washers $\Phi 8$, Plain Washers $\Phi 8$ (used for securing Remote Unit when hanged on bracket protrusions) | 2 pieces each |  |
| Masonry Bolt (set) M10x110 – used for <i>wall mount</i> installations | 6 |  |
| Hose Clamp ($\Phi 30$ - $\Phi 125$) - used for <i>pole mount</i> installations (2 per bracket) | 5 |  |

| Item | Qty. | Image |
|---|------|---|
| Optical Connector | 2 | - |
| Power Supply Cable (AC) | 1 |  |
| Copper Grounding Wire (2m) | 1 |  |
| RJ45 Ethernet Communication Cable | 1 |  |
| Key – used for opening unit panels for access to internal components. | 1 |  |

3. Check for signs of external damage. If there is any damage, call your MobileAccess service representative.

3.3.2 Required Tools

The following tools are the minimum required when installing the GX remote unit or performing routine maintenance:

- Electric Drill ($\Phi 12$ head for drilling holes for wall mount)
- Spanner (0.31 inch for tightening GX-Quad M8 nuts)

3.3.3 Mounting

CAUTION!

MobileAccessGX-Quad weighs 154.3lbs/70kg, take all necessary precautions when mounting. A minimum of two people is required for installing GX-Quad.

3.3.3.1 Wall Mount Installation

NOTE: The instructions provided in this section are for solid brick and concrete walls only.

To mount the unit on the wall

1. Select the wall mount location according to the following criteria:
 - General surroundings
 - Ventilated and easy-to-reach area (for maintenance and on-site inspection)
 - Proximity to the antenna in order to minimize cable loss
2. Using the mounting bracket top and bottom mounting holes as a guide (refer to Figure 3-4):
 - Measure and mark the location for drilling the (supplied) M10 Masonry bolts ($\Phi 12$) in the wall (6 per bracket and drill the holes).

NOTE: The GX-Quad unit is mounted vertically with the connectors facing downwards.

- Using an electric drill with a $\Phi 12$ head, drill the holes for the Masonry Bolts

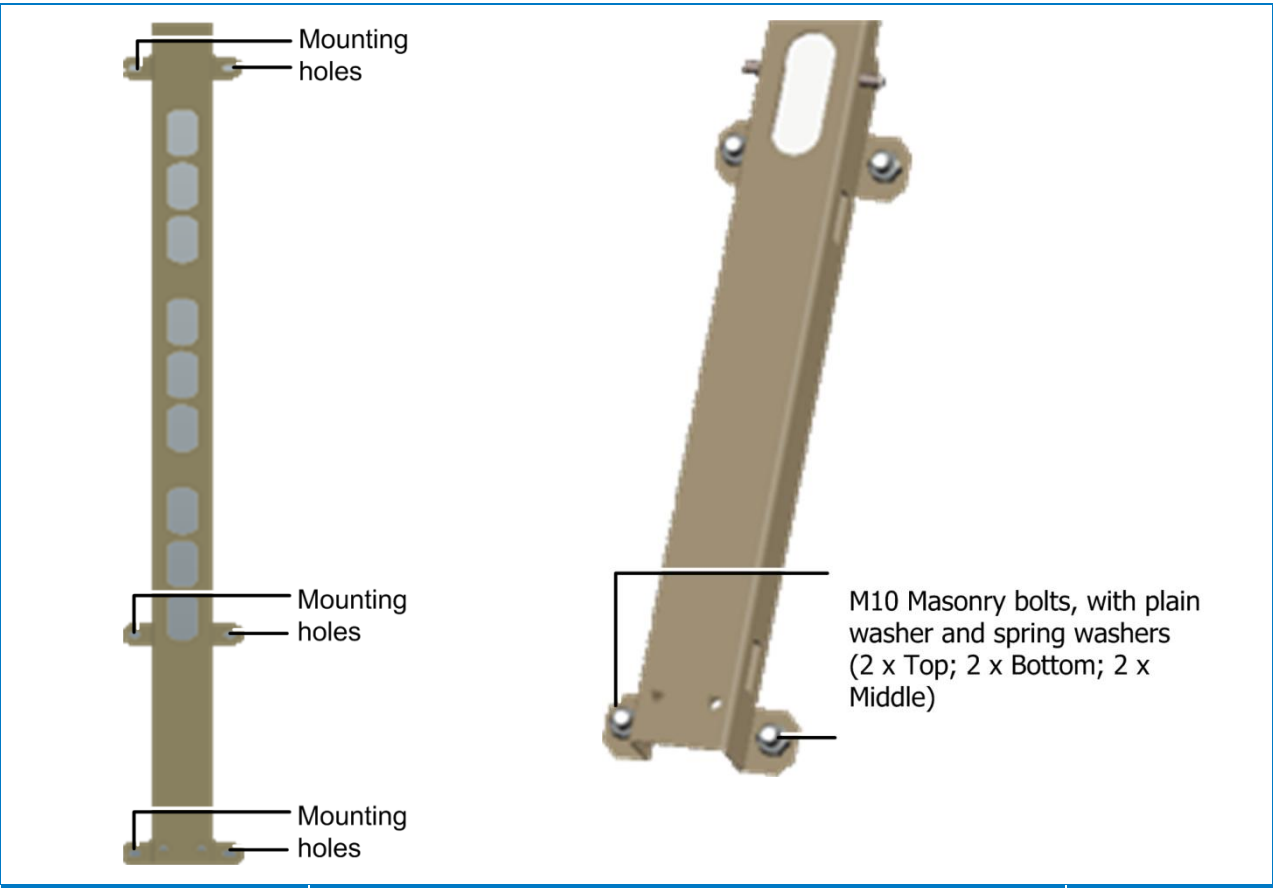

| | | | |
|---|-------------------|---|-------------------|
| Wall Mounted GX Mounting Bracket | Figure 3-4 | Detailed View of Wall Mounted Bracket – Middle and Bottom View | Figure 3-5 |
|---|-------------------|---|-------------------|

3. Using 6 (M10x110) Masonry bolts per bracket – secure the Mounting Brackets to the wall with the protruding M8 nuts *facing towards you*. The GX-Quad will be hung on these. See Figure 3-4 and Figure 3-5 .

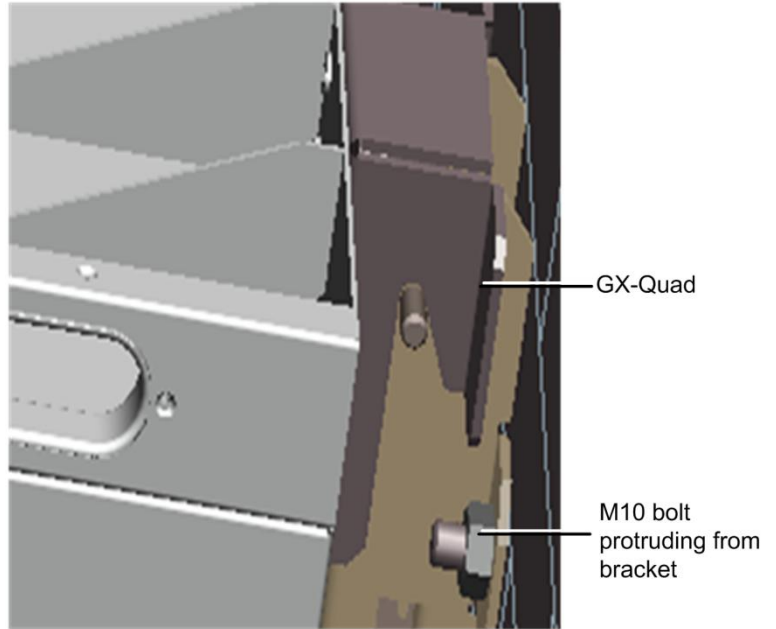
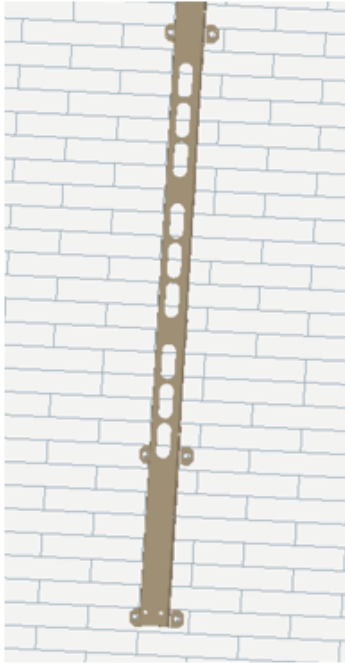

Wall Mounted GX Mounting Bracket

Figure 3-6 Hanging GX-Quad on Bracket

Figure 3-7

4. Connectors facing down, carefully fit and hang the GX unit on to the M10 bolts protruding from the top, middle and bottom parts of the mounting bracket. See Figure 3-7.

- Using a spanner or wrench, tighten the two (2) M8 nuts on the top and bottom of the mounting bracket as shown in Figure 3-8.

NOTE: It is recommended to use a threadlocker to tightly seal the nuts.

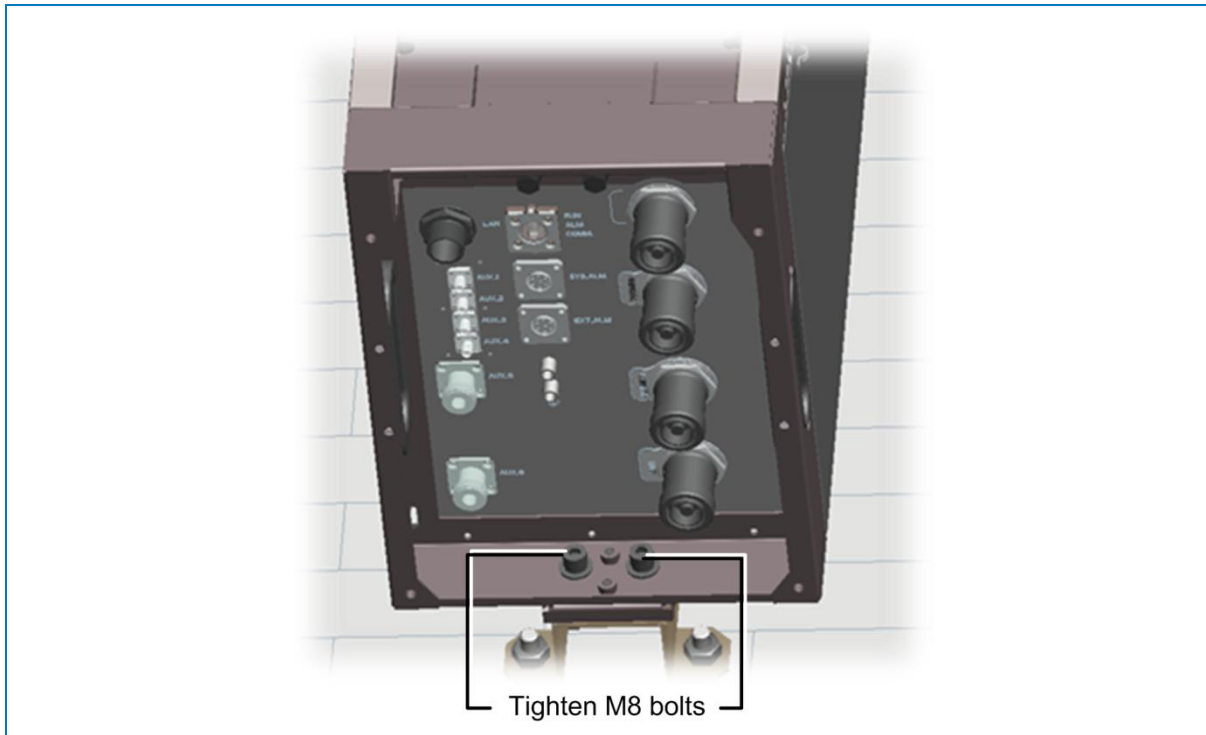

Wall Mounted GX – Bottom View | **Figure 3-8**

- Check enclosure position and verify that unit is mounted securely to the wall.

3.3.3.2 Pole Mount Installation

To mount the unit on a pole

1. Select the appropriate location according to the following criteria:
 - Accessibility
 - Antenna location and distance
 - Proximity to the antenna in order to minimize cable loss
2. Secure the mounting bracket by slipping the 5 hose clamps (provided) through the mounting bracket and tighten securely. Refer to Figure 3-9 and Figure 3-10.

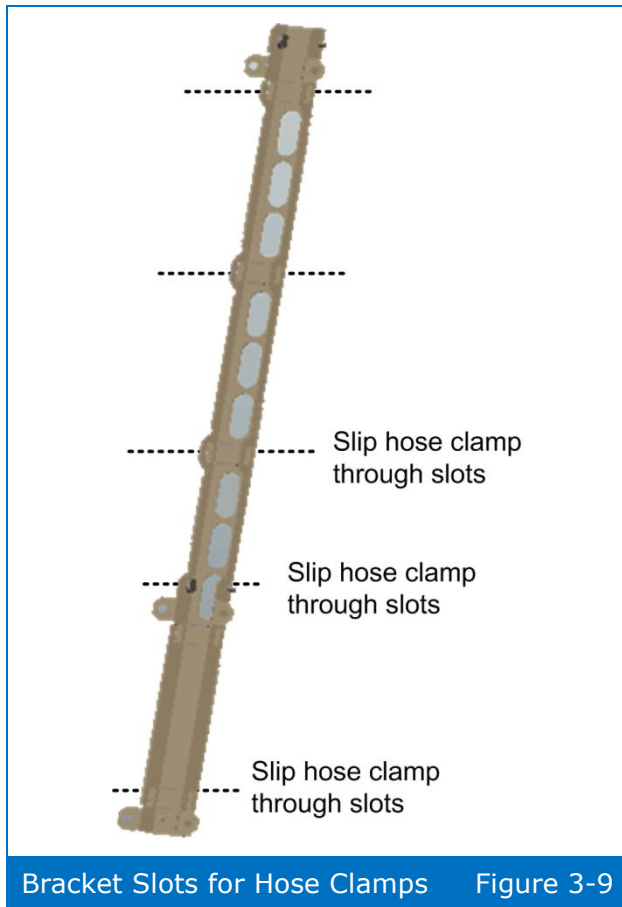

3. Connectors facing downwards, hook the GX-Quad on to the top part of the bracket and then to the bottom. Refer to Figure 3-11.
4. Using a spanner or wrench, tighten the two (2) M8 nuts on the top and bottom of the mounting bracket as shown in Figure 3-11 and Figure 3-12.

NOTE: It is recommended to use a threadlocker to tightly seal the nuts.

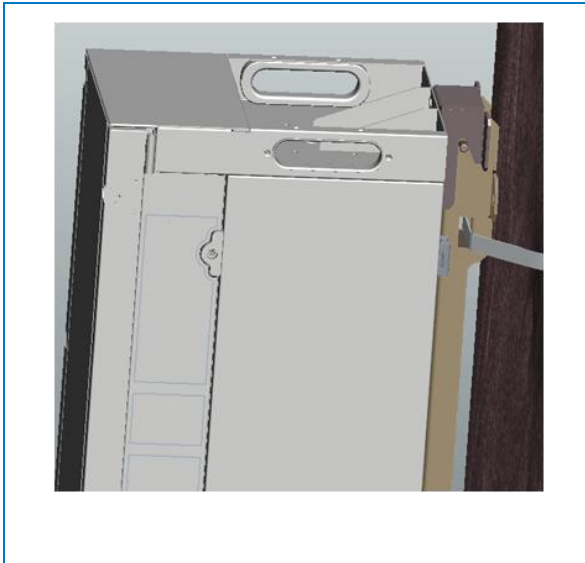

Hooking GX-Quad to Bracket

Figure 3-11

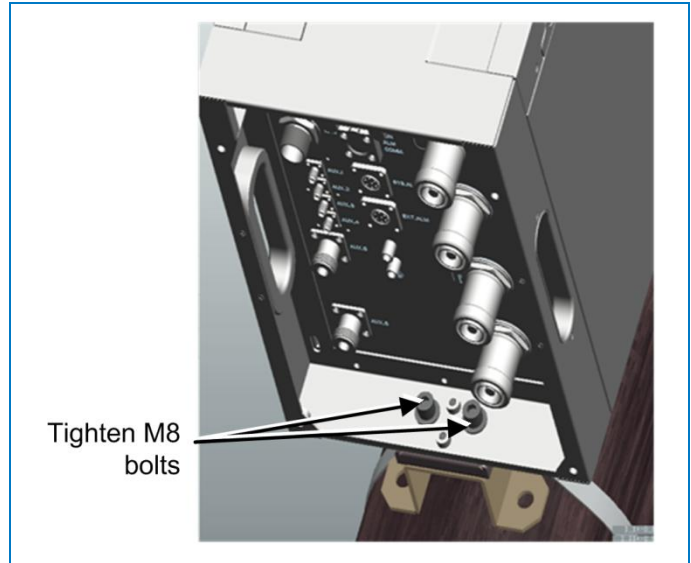

Pole Mounted GX - Bottom View

Figure 3-12



Pole Mounted GX-Quad

Figure 3-13

3.4 GX Connections

IMPORTANT – CABLE DRIP LOOPS!

It is highly recommended that every horizontal cable entry to the equipment forms a 'U' before its entry to the equipment. Water on the cable will drip down at the bottom of the loop and will not accumulate at the equipment connectors.

The connections are performed from the underside of the GX unit after it has been mounted.

3.4.1 Grounding Connections

WARNING!

This unit must always be grounded. Consult an appropriate electrical inspection authority or an electrician if you are uncertain that suitable grounding is available.

Do not connect power before grounding!

Connect the supplied copper wire (CSA 16mm²) GND cable to the GND connector and the equipment rack or building EARTH.

NOTE: An internationally acceptable color code of the ground connection wire is green/yellow.

To ensure safe operation of the product:

1. Ground the GX unit by connecting the "earth wire" of the power cord to the ground terminal of the AC supply.

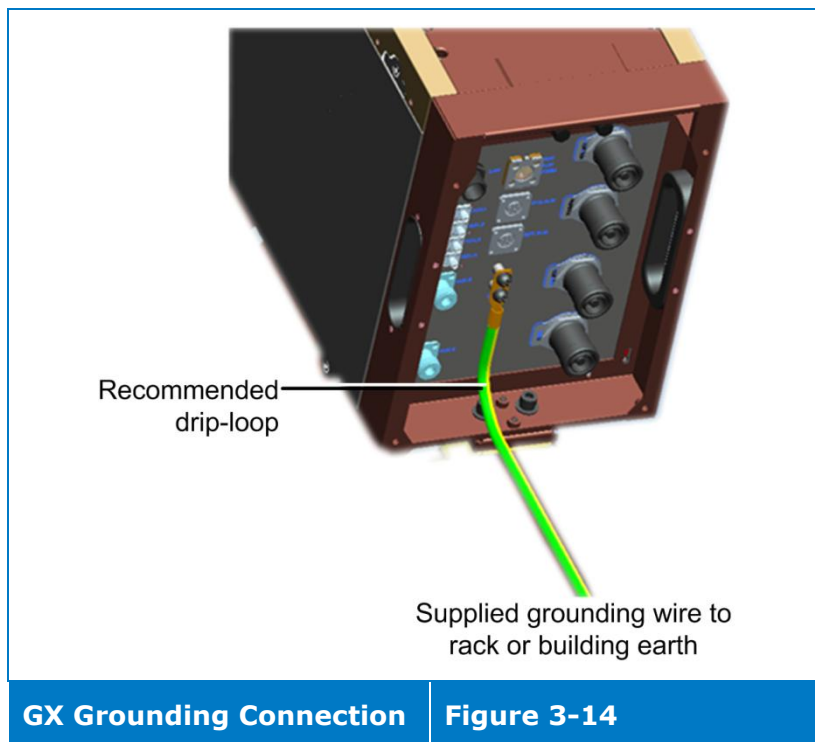

2. For installations with external combiner (AK-GX-FILT-COMB) – connect external combiner ground to building ground. See section 3.2 for grounding bolt location.

3.4.2 F/O Connections

Connect the GX-Quad **OP** (optic) OptiTap™ port to one of the OCH-GX front panel Link ports (via F/O patch panel) using the (2) provided optic connectors.

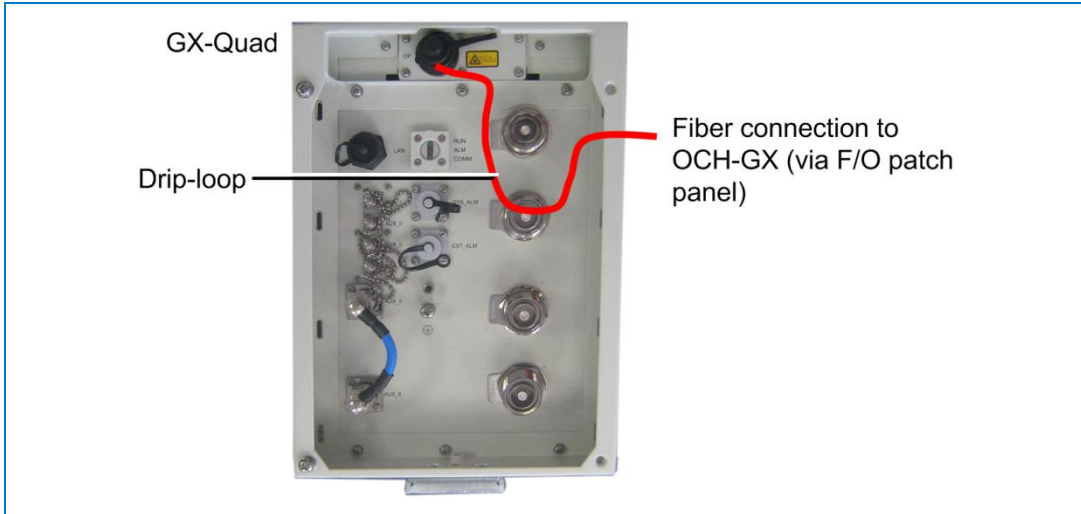

GX Optic Connector | **Figure 3-15**

3.4.3 RF Connections

To connect GX-Quad RF connections

1. Connect each relevant RF output (e.g. 1900MHz, 700MHz, AWS, CELL) to the corresponding service specific port of the combiner (e.g. GX AWS RF port to Combiner AWS port) using the provided DIN-M to DIN-M cable.

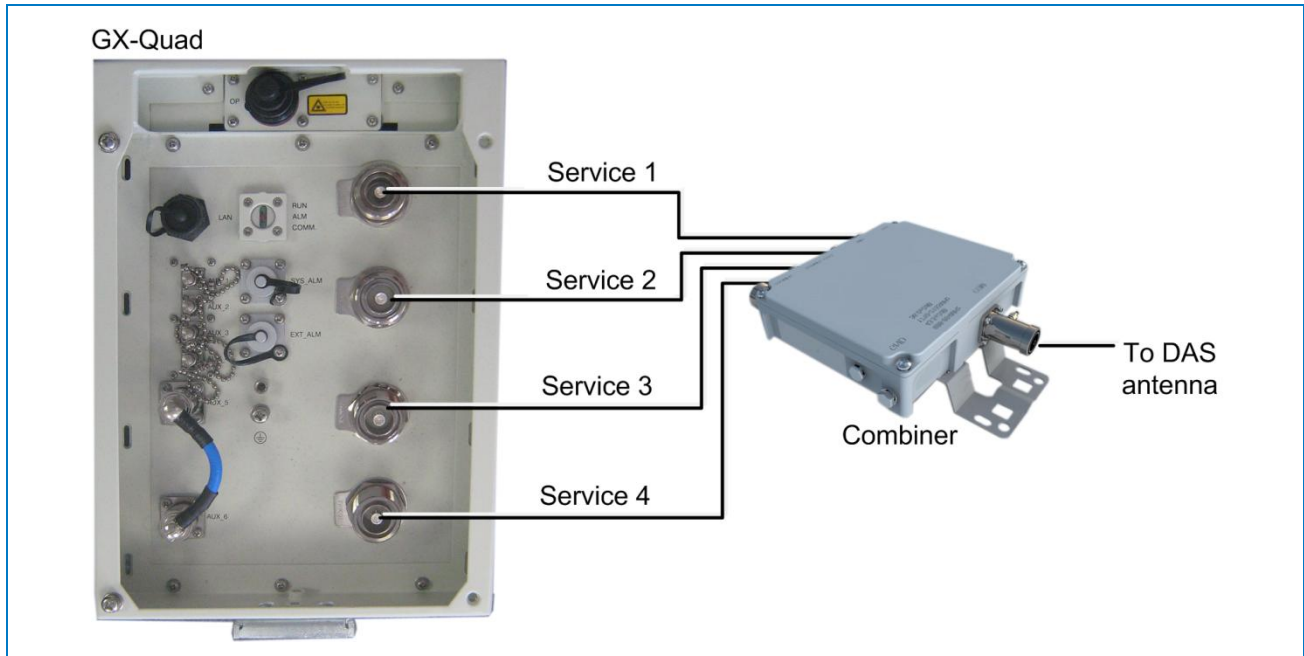

GX RF Connections with Combiner | **Figure 3-16**

2. Ensure lightning protection for each antenna.
3. Waterproof all RF ports.

3.4.4 Power Connections

CAUTION!

Any open RF port on GX or improper connection between GX RF ports and filter input ports will damage GX internal power amplifier after the equipment is powered on. Make sure all connections are performed correctly before powering.

To connect GX power

1. Unscrew the two screws of the side panel (shown in Figure 3-17) and open to access the power connector.

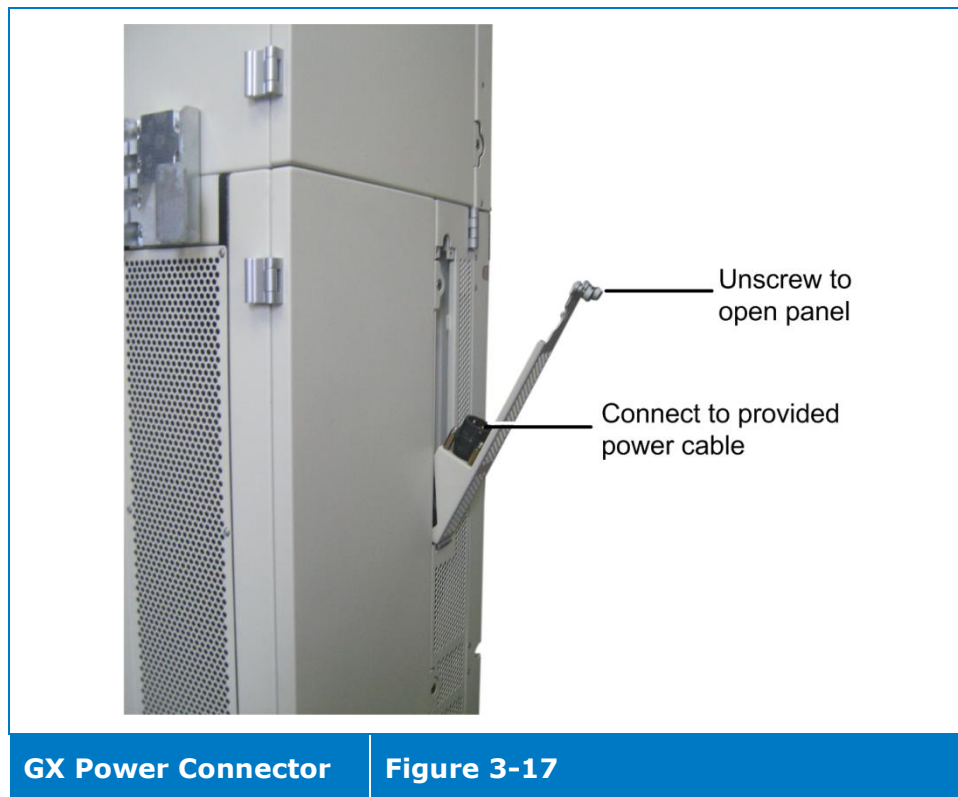

2. For a LOCAL AC connection - connect the supplied power cable to the power supply port (100-240VAC, 20A maximum).

3.4.5 External Alarm Connections

The GX-Quad EXT_ALM port supports up to four dry-contact alarm connections from external sources (incoming outputs). The alarms can be connected any time, before or after the system is powered-on.

NOTE: After being connected, the External Alarms must be enabled from the Web Management application (see SC-450 v4.5 UM).

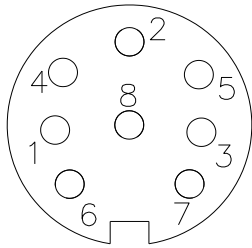

| Pin No. | Description |
|---------|-------------|
| 1 | EXT_ALM1 |
| 2 | EXT_COM1 |
| 3 | EXT_ALM2 |
| 4 | EXT_COM2 |
| 5 | EXT_ALM3 |
| 6 | EXT_COM3 |
| 7 | EXT_ALM4 |
| 8 | EXT_COM4 |

3.4.6 System Alarm Pin-Out Description

The GX-Quad System Alarm pin-out connector supports 3 relay alarm connections. GX-Quad status alarms can be relayed via a network or modem connection.

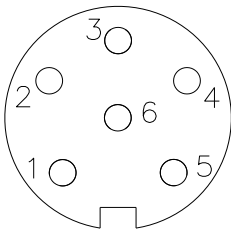

| Pin No. | Description |
|---------|-------------|
| 1 | EXT_OPEN |
| 2 | EXT_COM |
| 3 | EXT_CLOSE |

3.5 Verifying Normal Operation

Upon powering up the GX-Quad remote unit:

- Confirm the fans are working after powering.
- Verify normal operation:

| LED | Description |
|-------|--|
| RUN | Flashing Green - Flashes green for the duration of a minute upon system initialization Off - System initialized |
| COMM. | Flashing Green - Flashes (rate of flash per second) for the duration of 1 minute upon communication initialization Rapid/No Flash - Indicates communication fault |
| ALM | Steady Red - Fault Off - Normal operation |

Appendix A: System Specifications

RF Parameters

Supported Services

| Technologies | Band | Frequency Range | |
|----------------------------|---------|------------------------|-----------|
| | | Uplink | Downlink |
| CDMA / WCDMA* / TDMA / GSM | CELL850 | 824-849 | 869-894 |
| CDMA / WCDMA* / TDMA / GSM | PCS1900 | 1850-1915 | 1930-1995 |
| WCDMA* / HSPA / LTE | AWS2100 | 1710-1755 | 2110-2155 |
| LTE | 700MHz | 698-716 and 776-787 | 728-757 |

(*)WCDMA service is based on 3GPP standards, LTE service may be deployed in the future due to frequencies re-farming planned by the operators as well

RF Parameters per Service

| RF Parameters | | | | | | | | |
|--|------------|-----|-----------------------------|-----|------------------------|-----|------------------------|-----|
| MobileAccessGX-Quad RF Parameters | LTE 700MHz | | CELL TDMA CDMA/WCDMA 850MHz | | PCS CDMA/WCDMA 1900MHz | | AWS CDMA/WCDMA 2100MHz | |
| | DL | UL | DL | UL | DL | UL | DL | UL |
| Max Output Power 1 Carrier (Composite) | 46 | | 46 | | 46 | | 46 | |
| 2 Carriers | 43 | | 43 | | 40 | | 43 | |
| 4 Carriers | 40 | | 40 | | 37 | | 40 | |
| 8 Carriers | - | | 37 | | 34 | | 37 | |
| 12 Carriers | - | | 35 | | 32 | | 35 | |
| 24 Carriers | - | | 32 | | 29 | | 32 | |
| Mean Gain (dB) ¹ | 68 | 50 | 68 | 50 | 68 | 50 | 68 | 50 |
| Gain Range (dB) | 30 | 30 | 30 | 30 | 30 | 30 | 30 | 30 |
| Pin (dBm) | -20 | -54 | -20 | -54 | -20 | -54 | -20 | -54 |
| Max Intermod Distortion (dBm) | -13** | | -13* | | -13* | | -13* | |
| NF (dB) Typical | | 5 | | 5 | | 5 | | 5 |
| VSWR | 1.5:1 | | | | | | | |
| Gain Flatness/Ripple (dB) ² | +/- 2.0 | | | | | | | |

* WCDMA complies with 3GPP TS 25.106 V5.0.0 (2002-03) table 9.4 spectrum emission mask.

** Out of band and spurious emissions compliant to FCC.

***Default Conditioner (BTSC) UL Gain=+3dB

¹Factory set mean gain OCH-GX-GX without RIU. May be field adjusted using controller system.

²Gain Flatness/Ripple is specified for the non-duplexed port of the system.

Optical Specifications

| | |
|--|----------------------|
| Max. Optical Budget | 8.0 dBo |
| Optical Return Loss | > 50dB |
| Optical Loss per Mated-pair Connectors | 0.5dB (max) |
| Optical Connector | SC/APC |
| Optical Automatic Gain Control Range | -2~-10dBm |
| Fiber Type | Single-mode: 9/125um |
| Wavelength | 1310nm, 1550nm + WDM |

Physical Specifications

| | |
|--------------------------|---|
| Ports | Corning Optitap Fiber-optic waterproof connectors RF DIN Female connectors |
| Power | Remote power VAC 100-240/47-63Hz with Max.Power Consumption: 1600W |
| Physical Characteristics | Mounting: Wall or Pole Dimensions (HXWxD) in (mm): 53 x 12.4 x 8.9 (1350 x 315 x 225) Weight kg (lbs): 70 (154.3) |
| Cooling Feature | Active heat dissipation (Fan) |

Environmental Specifications

| | |
|-----------------------|--|
| Operating Temperature | -40 to +70°C (-40 to +158°F) |
| Humidity | ≤95 % |
| Enclosure | NEBS OSP Class 4 rated (Enclosure protected from elements and waterproofing) |

Appendix B: Ordering Information

NOTE: The information listed below is updated up to the document publishing date. Refer to the GX-Quad datasheet for the most updated ordering information.

MobileAccessGX-Quad Remote Units

| Service Supported | Part Number | Description |
|---------------------|---------------------|--|
| CELL/700LTE/AWS 40W | GX-C85P19L70A17-40 | MobileAccess GX Quad-Hardware with service CELL, PCS, AWS and 700 MHz LTE solution supporting 40W output power. |
| CELL/PCS/700LTE 40W | GX-LIC-C85P19L70-40 | MobileAccessGX Quad-Hardware with licensed service CELL, PCS and 700 MHz LTE solution supporting 40W output power. |
| AWS 40W | GX-LIC-AO-A17-40 | MobileAccess GX licensed service Add on for AWS solution supporting 40W output power. |

Optical Central Hub (OCH) - GX International products

| Part Number | Description |
|-------------|---|
| OCH-GX-4-XR | Optical Central Hub for SISO services, extended range up to 20Km, supporting (4) SISO GX units, SMF (WDM) |
| OCH-GX-8-XR | Optical Central Hub for SISO or MIMO services, extended range up to 20Km, supporting (8) SISO or (4) MIMO GX units, SMF (WDM) |

Accessories

| Part Number | Description |
|-----------------------|---|
| AK-GX-FILT-COMB | MobileAccessGX Accessorized 4 to 1 external multiplexer |
| AK-GX-ELEC-ADAPT-AC | AC Electrical junction adapter IP67 rated |
| AK-3COUPLER-DINM-DINF | 7/16 DIN Female to 7/16 DIN Male with QMA coupling port |
| AK-RIU4-OCH-CABLES | Accessory Kit Cables for RIU4 to OCH, 4 QMA to QMA R/A cables 1 Meter |