

7.2.4 Radiated Spurious Emissions

Test Date: 2012-08-29

Test Requirement: FCC part 22.917(a) & FCC part 27.53(h)
 22.917(a) Out of band emissions. The power of any emission outside of the authorized operating frequency ranges must be attenuated below the transmitting power (P) by a factor of at least $43 + 10 \log(P)$ dB.

27.53(h) For operations in the 1710–1755 MHz and 2110–2155 MHz bands, the power of any emission outside a licensee's frequency block shall be attenuated below the transmitter power (P) by at least $43 + 10 \log_{10}(P)$ dB.

Test Method: FCC part 2.1053
 ANSI/TIA-603-C-2004

EUT Operation:
 Status: Drive the EUT to maximum output power.
 Conditions: Normal conditions
 Application: Enclosure

Test Configuration:

30MHz to 1GHz emissions:

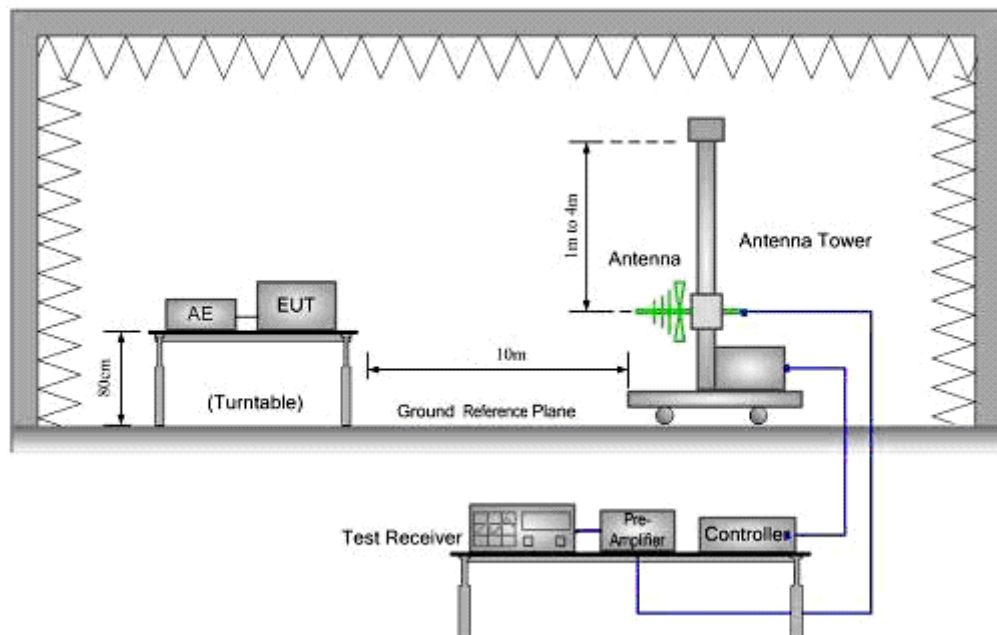

1GHz to 40GHz emissions:

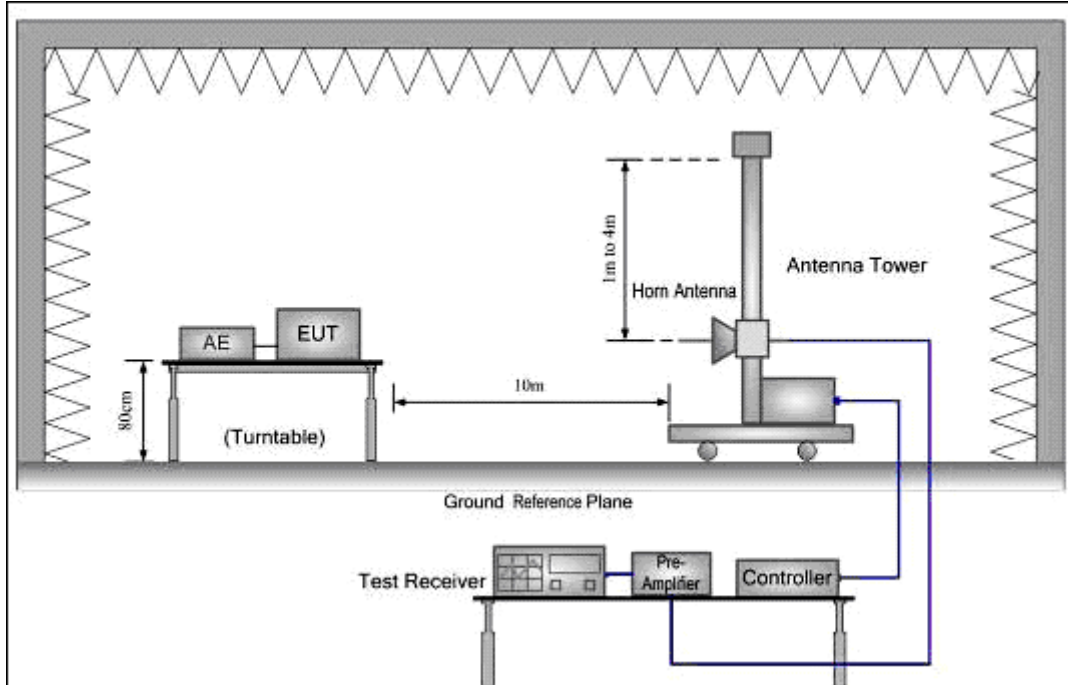

Test Procedure:

1. Test the background noise level with all the test facilities;
2. Keep one transmitting path, all other connectors shall be connected by normal power or RF leads;
3. Select the suitable RF notch filter to avoid the test receiver or spectrum analyzer produce unwanted spurious emissions;
4. Keep the EUT continuously transmitting in max power;
5. Read the radiated emissions of the EUT enclosure.

Radiated Emissions Test Procedure:

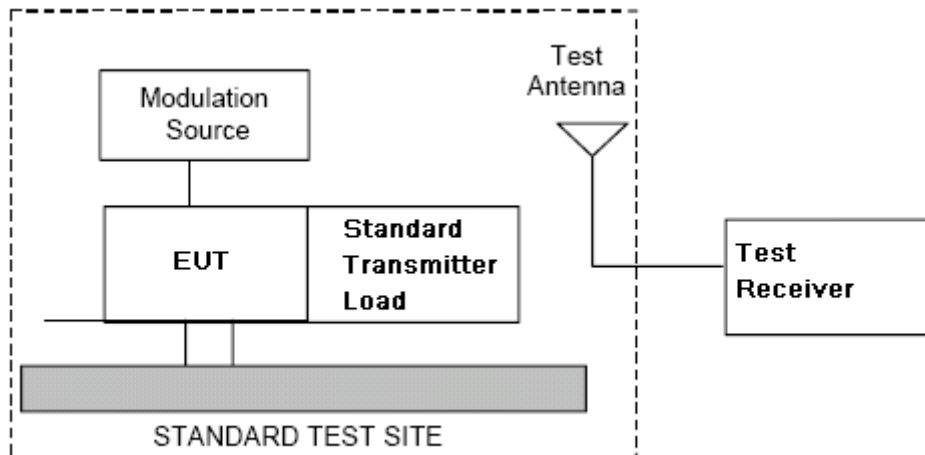

- a) Connect the equipment as illustrated.
- b) Adjust the spectrum analyzer for the following settings:
 - 1) Resolution Bandwidth = 100 kHz for spurious emissions below 1 GHz, and 1 MHz for spurious emissions above 1GHz.
 - 2) Video Bandwidth = 300 kHz for spurious emissions below 1 GHz, and 3 MHz for spurious emissions above 1 GHz.
 - 3) Sweep Speed slow enough to maintain measurement calibration.
 - 4) Detector Mode = Positive Peak.
- c) Place the transmitter to be tested on the turntable in the standard test site, The transmitter is transmitting into a nonradiating load that is placed on the turntable. The RF cable to this load should be of minimum length.
- d) Measurements shall be made from 30MHz to 10 times of fundamental carrier, except for the region close to the carrier equal to \pm the carrier bandwidth.
- e) Key the transmitter without modulation or normal modulation base the standard.
- f) For each spurious frequency, raise and lower the test antenna from 1 m to 4 m to obtain a maximum reading on the spectrum analyzer with the test antenna at horizontal polarity. Then the turntable should be rotated 360° to determine the maximum reading. Repeat this procedure to obtain the highest possible reading. Record this maximum reading.
- g) Repeat step f) for each spurious frequency with the test antenna polarized vertically.

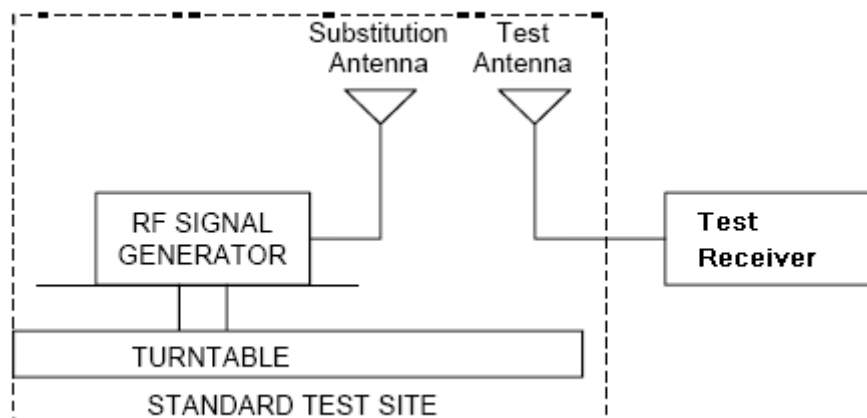



- h) Reconnect the equipment as illustrated.
- i) Keep the spectrum analyzer adjusted as in step b).
- j) Remove the transmitter and replace it with a substitution antenna (the antenna should be half-wavelength for each frequency involved). The center of the substitution antenna should be approximately at the same location as the center of the transmitter. At the lower frequencies, where the substitution antenna is very long, this will be impossible to achieve when the antenna is polarized vertically. In such case the lower end of the antenna should be 0.3 m above the ground.
- k) Feed the substitution antenna at the transmitter end with a signal generator connected to the antenna by means of a nonradiating cable. With the antennas at both ends horizontally polarized, and with the signal generator tuned to a particular spurious frequency, raise and lower the test antenna to obtain a maximum reading at the spectrum analyzer. Adjust the level of the signal generator output until the previously recorded maximum reading for this set of conditions is obtained. This should be done carefully repeating the adjustment of the test antenna and generator output.
- l) Repeat step k) with both antennas vertically polarized for each spurious frequency.
- m) Calculate power in dBm into a reference ideal half-wave dipole antenna by reducing the readings obtained in steps k) and l) by the power loss in the cable between the generator and the antenna, and further corrected for the gain of the substitution antenna used relative to an ideal half-wave dipole

antenna by the following formula:

$$Pd(\text{dBm}) = Pg(\text{dBm}) - \text{cable loss (dB)} + \text{antenna gain (dB)}$$

where:

Pd is the dipole equivalent power and

Pg is the generator output power into the substitution antenna.

NOTE: It is permissible to use other antennas provided they can be referenced to a dipole.

NOTE: Effective radiated power (e.r.p) refers to the radiation of a half wave tuned dipole instead of an isotropic antenna. There is a constant difference of 2.15 dB between e.i.r.p. and e.r.p.

$$\text{e.r.p (dBm)} = \text{e.i.r.p. (dBm)} - 2.15$$



7.2.4.1 Measurement Record:

No emissions were detected within 20dB below the limit for the Downlink direction.

Remark:

The cabinet radiation was measured with the equipment transmitting a CW signal into a non-radiating 50 Ohm load at maximum output power on a signal frequency .

Measured were performed in the lowest, middle and highest frequency for : the Downlink.

The spectrum was searched from 30MHz to 26GHz (10th Harmonic) for downlink;

7.2.5 Occupied Bandwidth

Test Date: 2012-08-20 to 2012-08-23

Test Requirement: 2-11-04/EAB/RF

Test Method: FCC part 2.1049, 2-11-04/EAB/RF

The spectral shape of the output should look similar to input for all modulations.

EUT Operation:

Status: Drive the EUT to maximum output power. .

Conditions: Normal conditions

Application: Cellular Band RF output ports

Test Configuration:

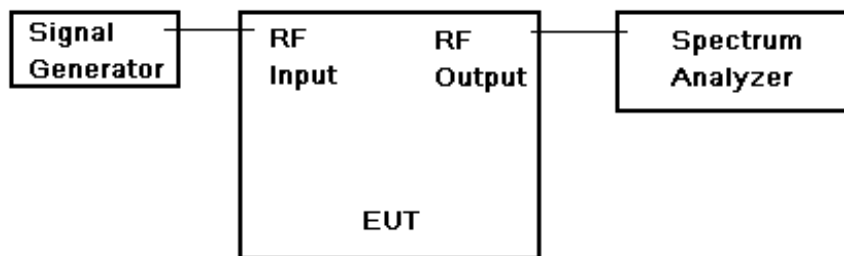

Fig.2. Conducted Spurious Emissions test configuration

Test Procedure:

- a) Set the spectrum analyzer RBW 300 Hz or $>1\%$ & $<2\%$ emission bandwidth of carrier.
- b) Capture the trace of input signal;
- c) Connect the equipment as illustrated;
- d) Capture the trace of output signal;



7.2.5.1 Measurement Record:

1.Downlink:728MHz to 757MHz(LTE mode)

1.1 lowest frequency -- Input

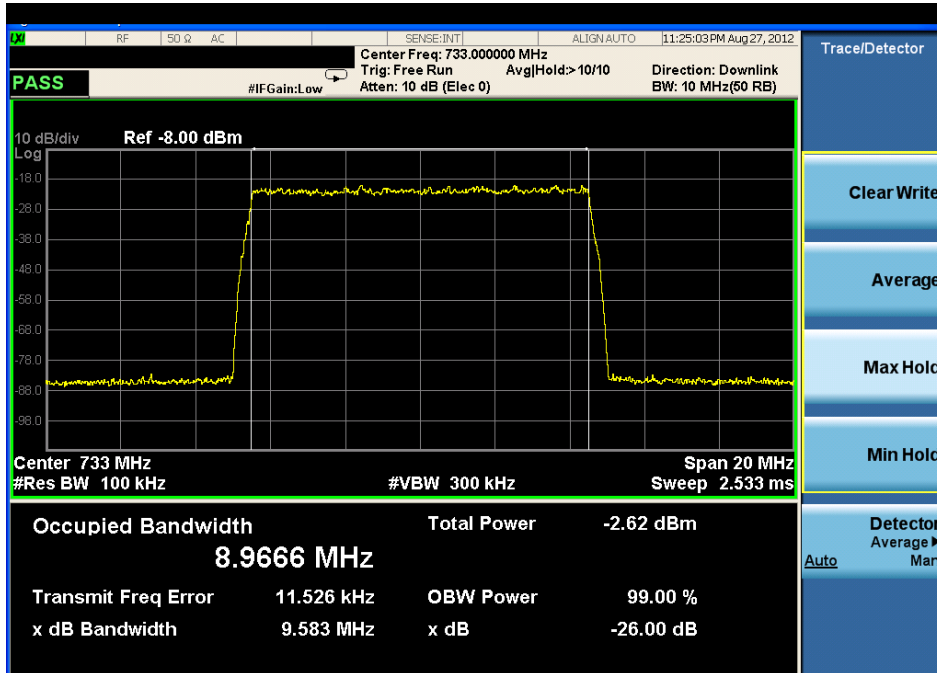

1.2 lowest frequency-- Output

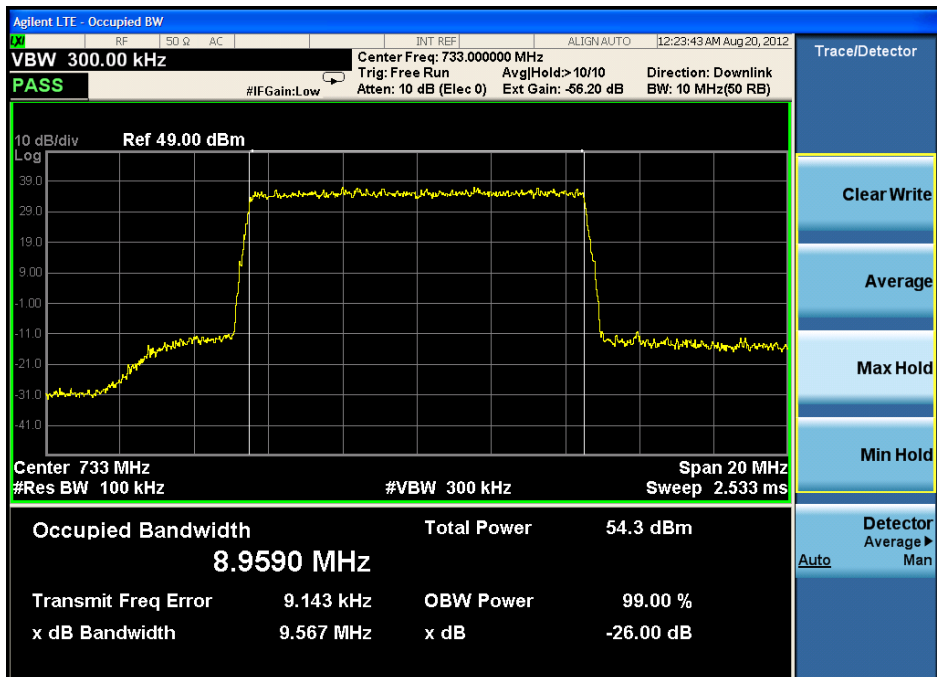



1.3 middle frequency-- Input

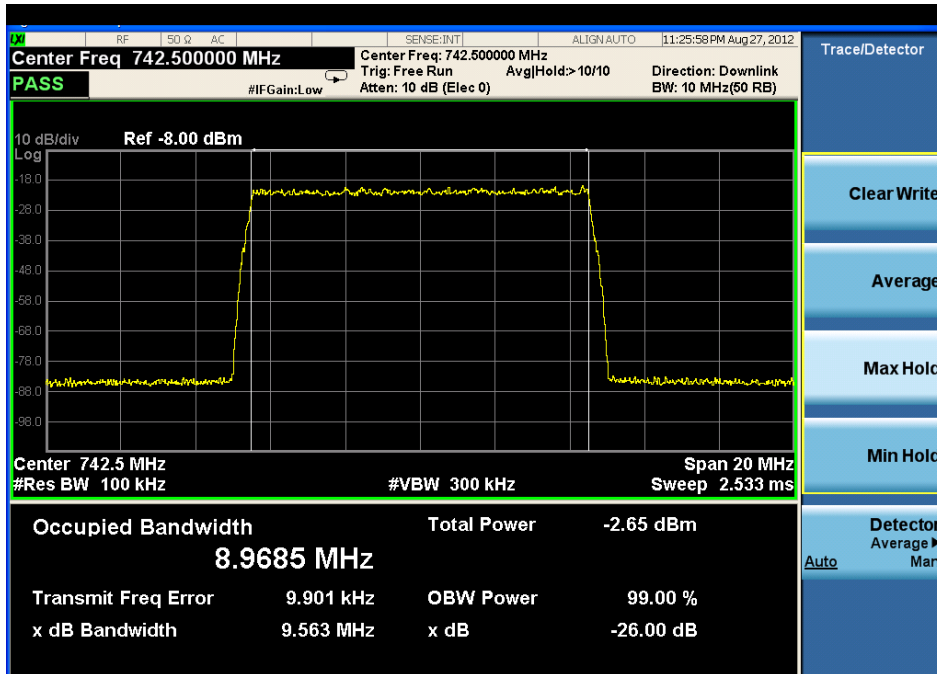

1.4 middle frequency-- Output

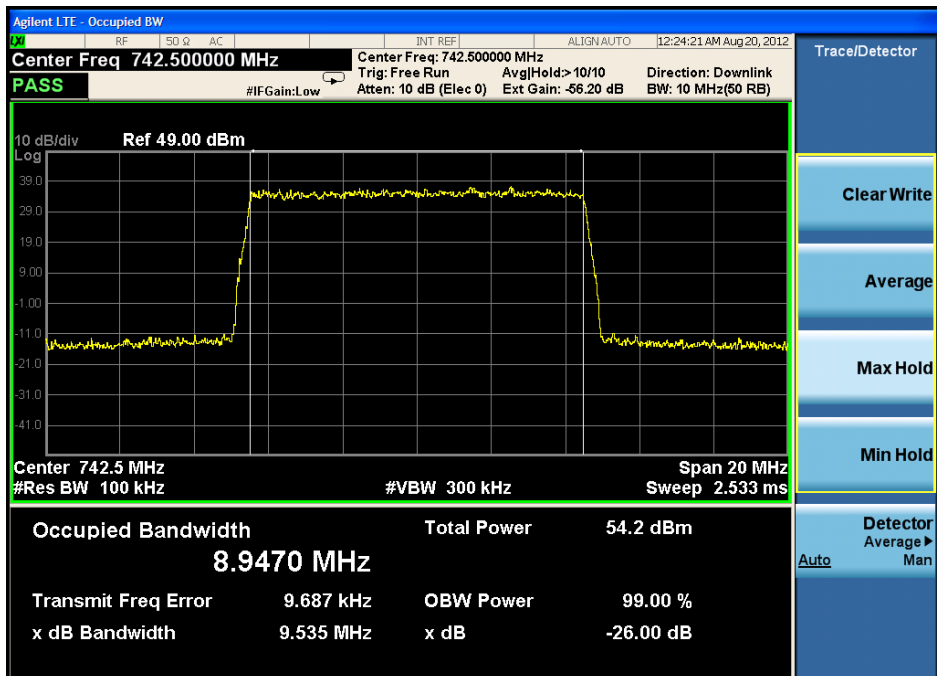



1.5 highest frequency—Input

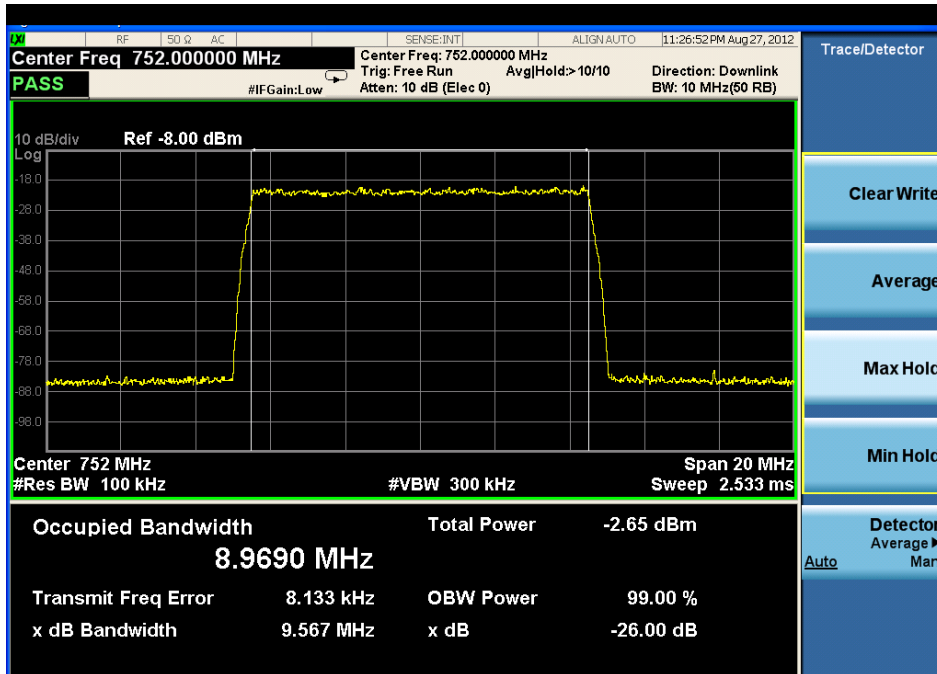

1.6 highest frequency--Output

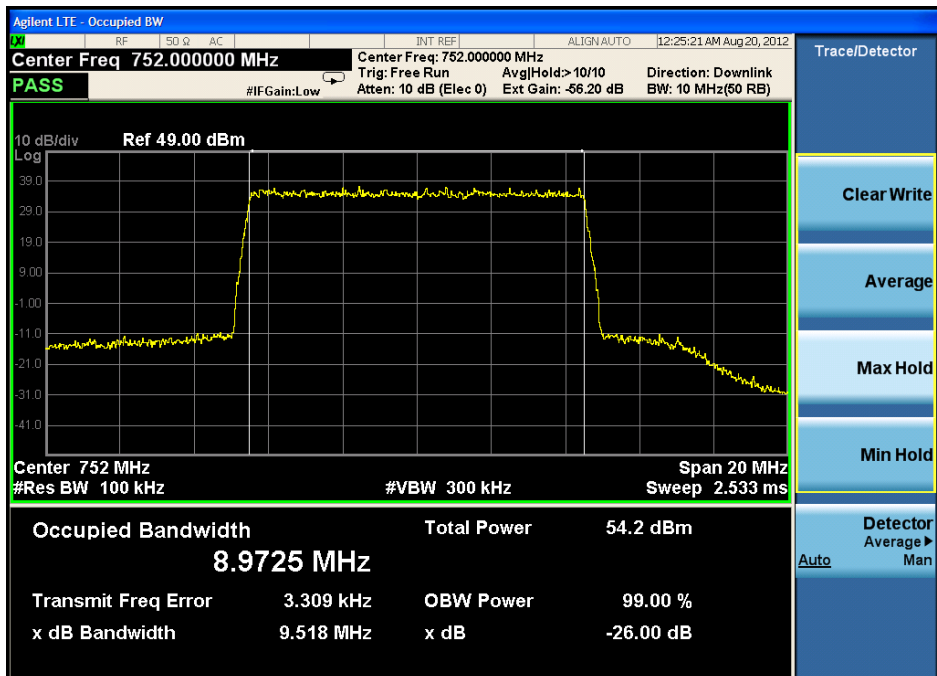



2. Downlink: 869MHz to 894MHz(GSM,CDMA,WCDMA,LTE)

2.1 GSM Mode:

2.1.1 lowest frequency-- Input

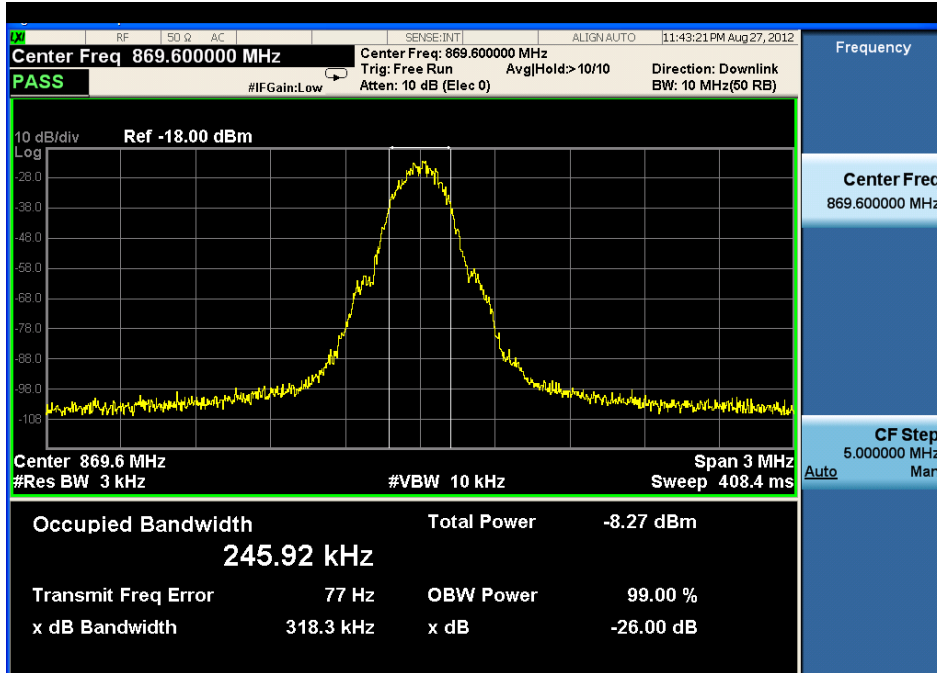

2.1.2 lowest frequency-- Output

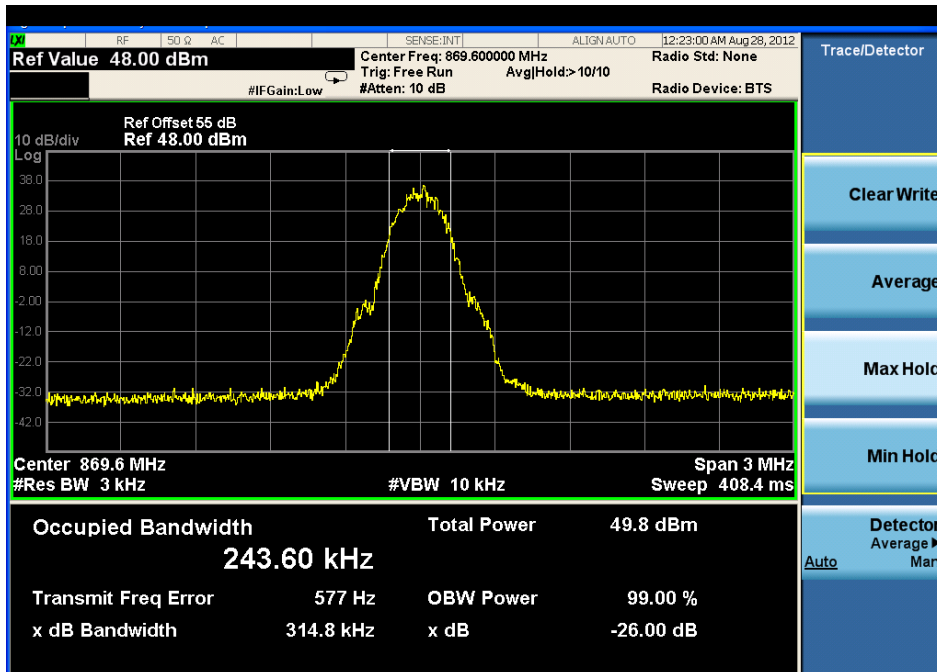



2.1.3 middle frequency-- Input

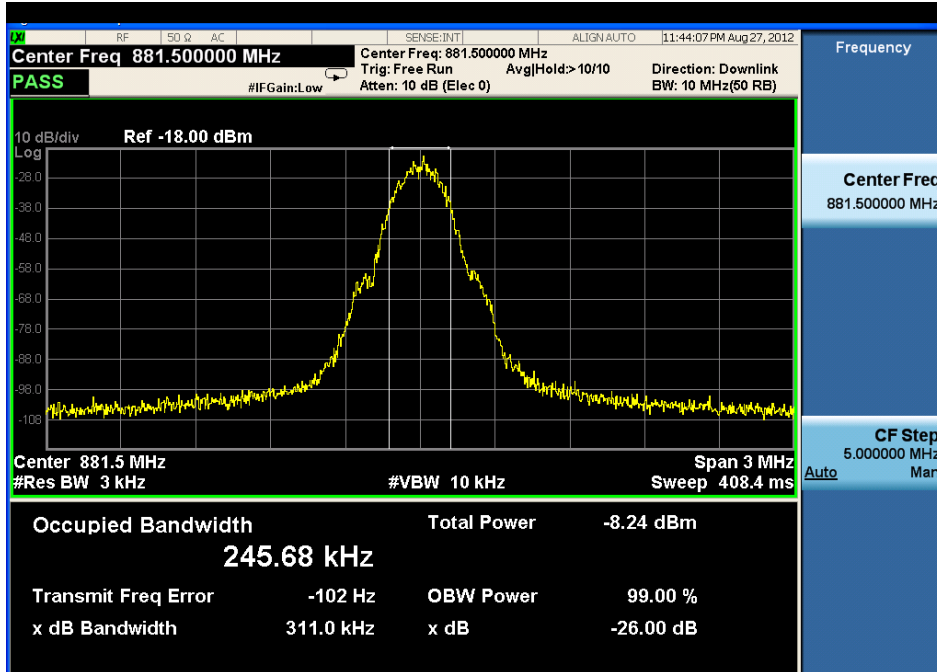

2.1.4 middle frequency-- Output

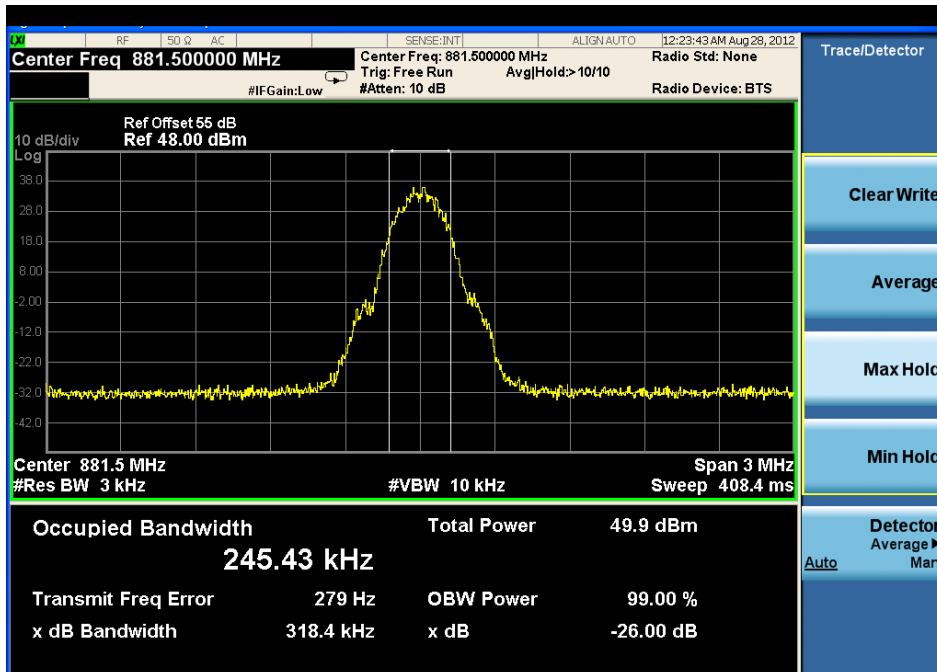



2.1.5 highest frequency—Input

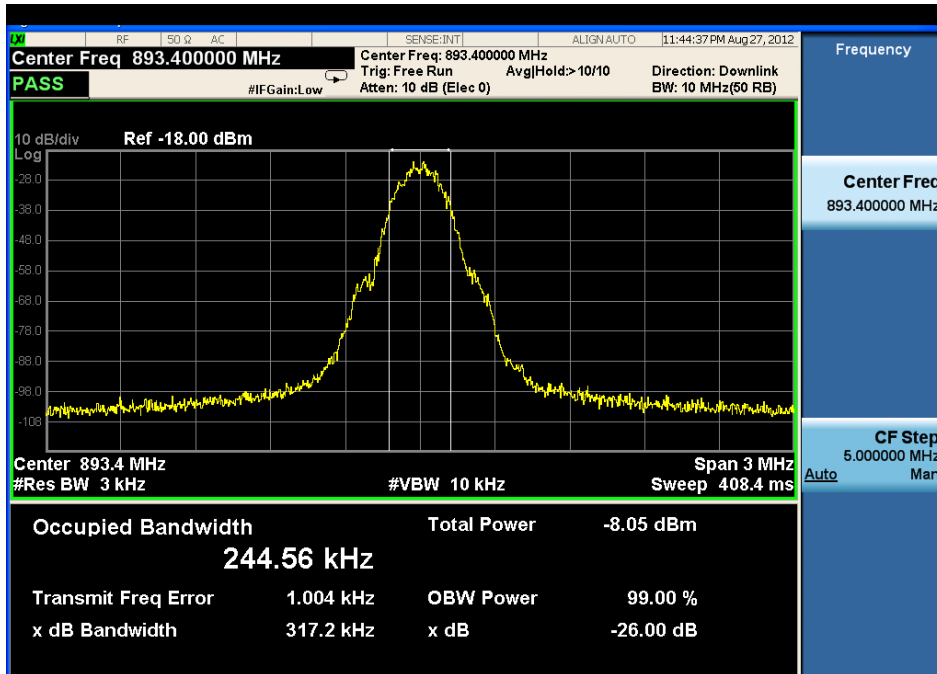

2.1.6 highest frequency--Output

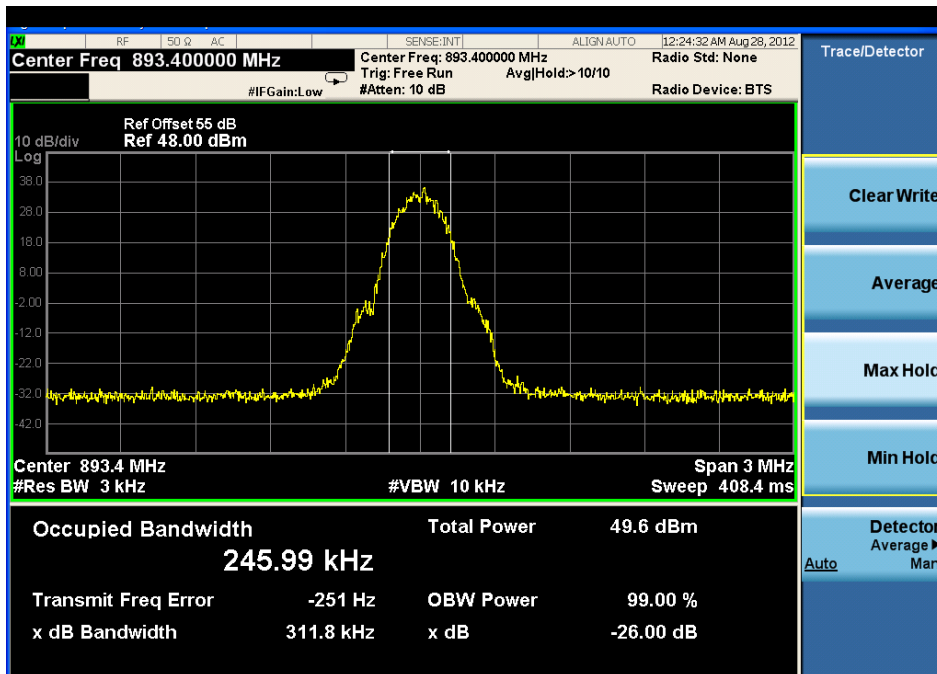



2.2 CDMA Mode:

2.2.1 lowest frequency-- Input

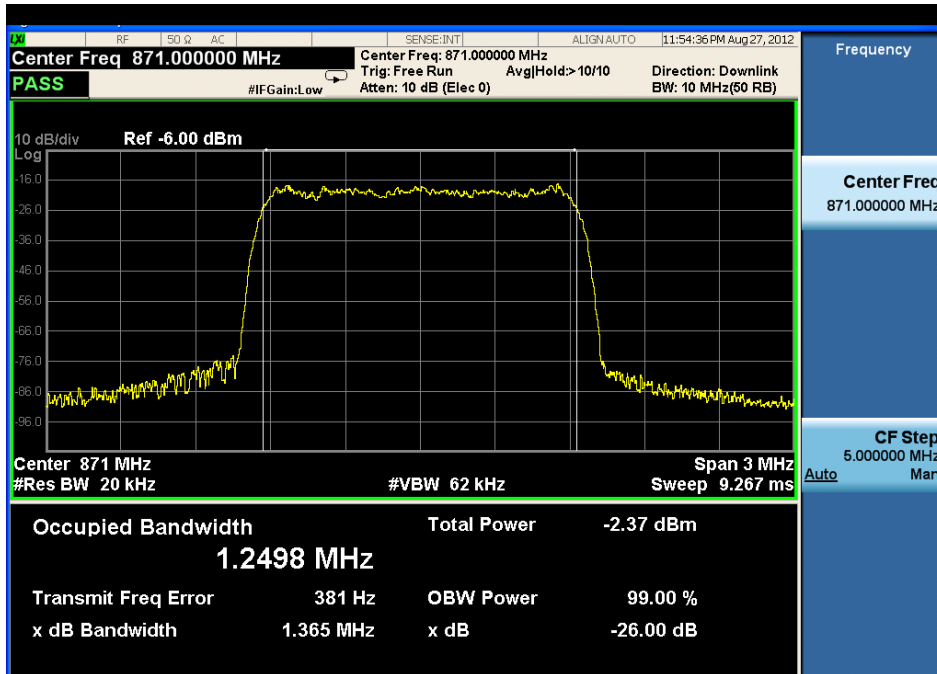

2.2.2 lowest frequency-- Output

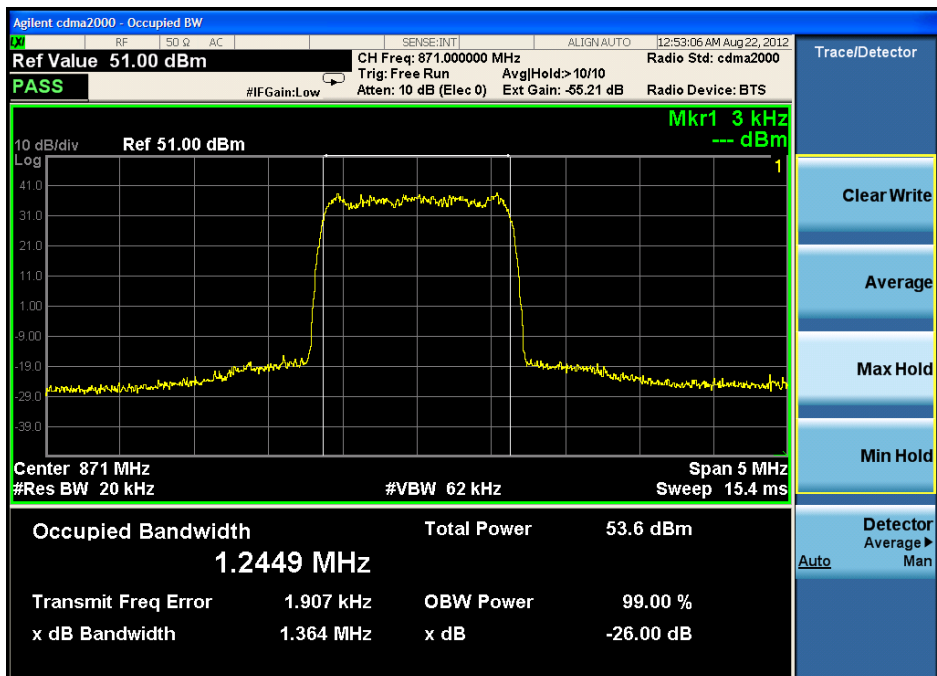



2.2.3 middle frequency-- Input

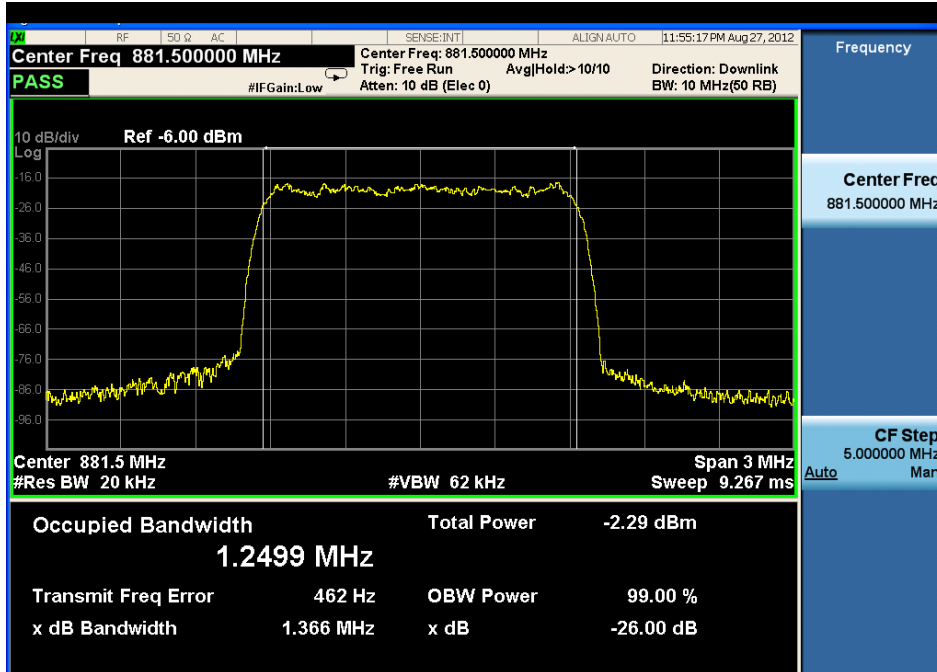

2.2.4 middle frequency-- Output

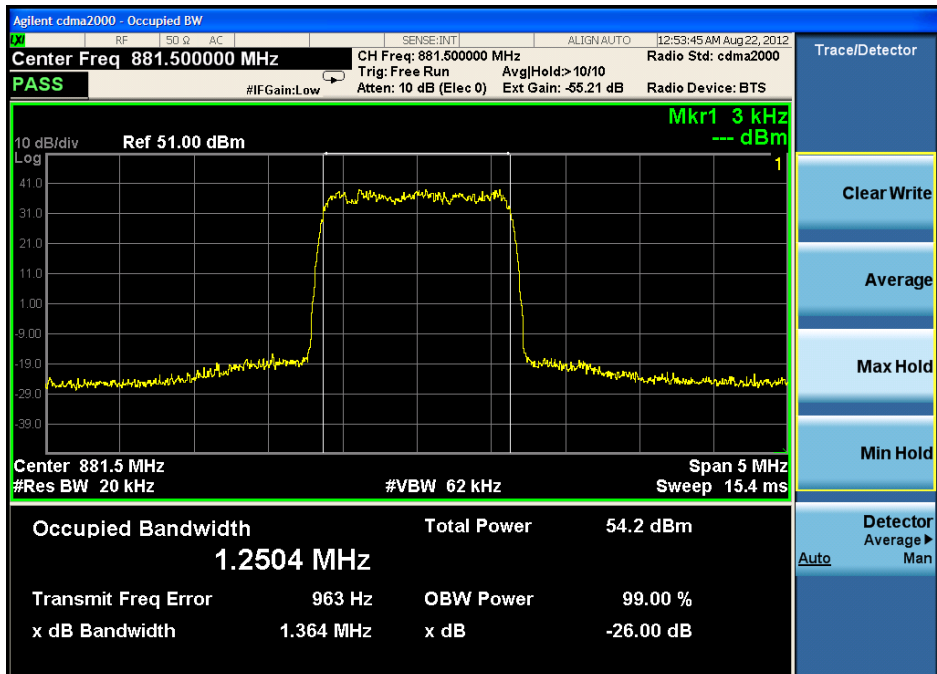



2.2.5 highest frequency—Input

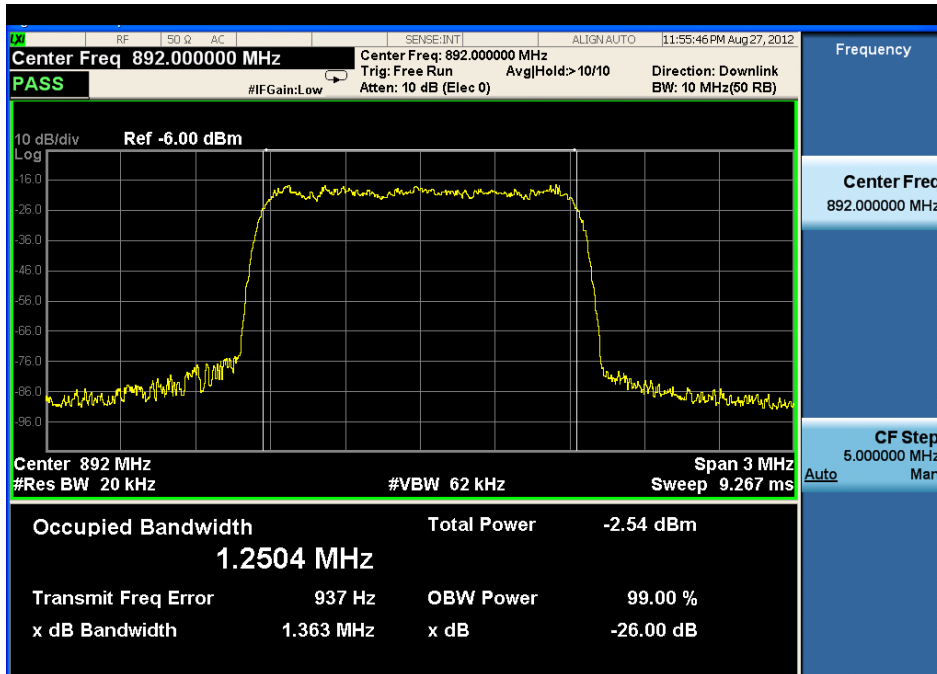

2.2.6 highest frequency--Output

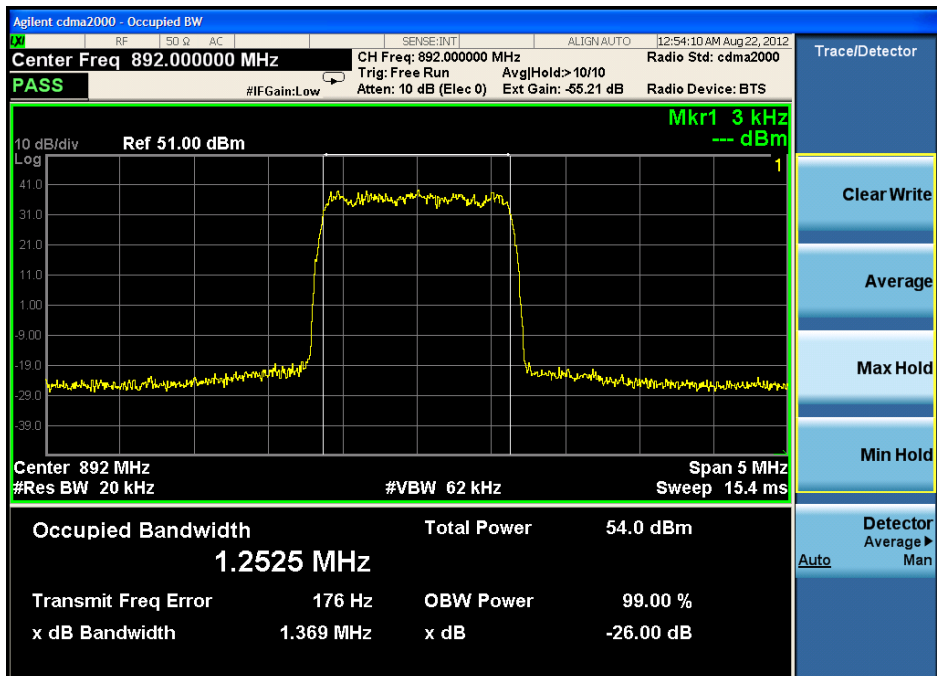



2.3 WCDMA Mode:

2.3.1 lowest frequency-- Input

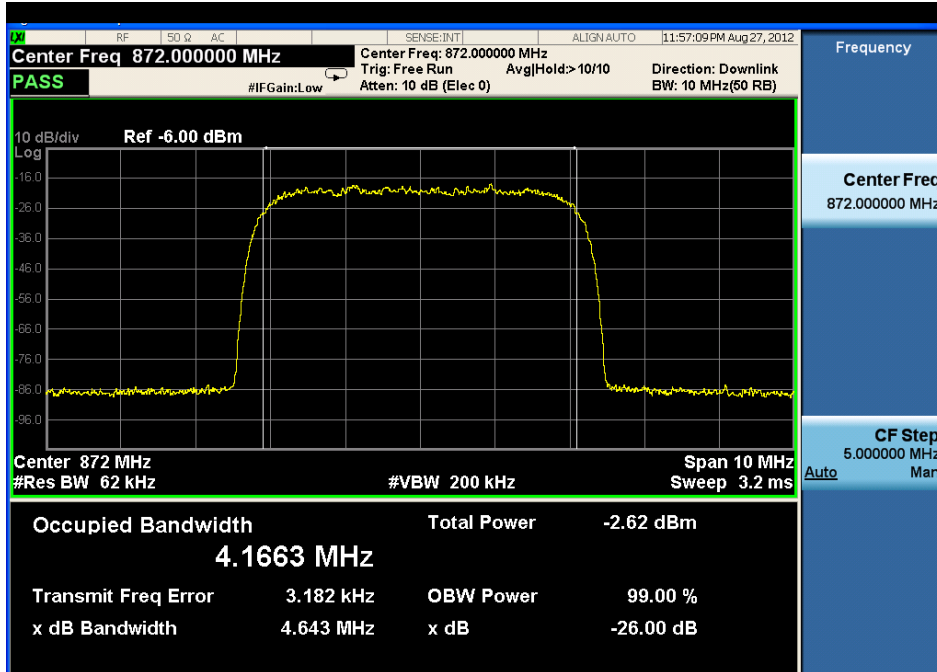

2.3.2 lowest frequency-- Output

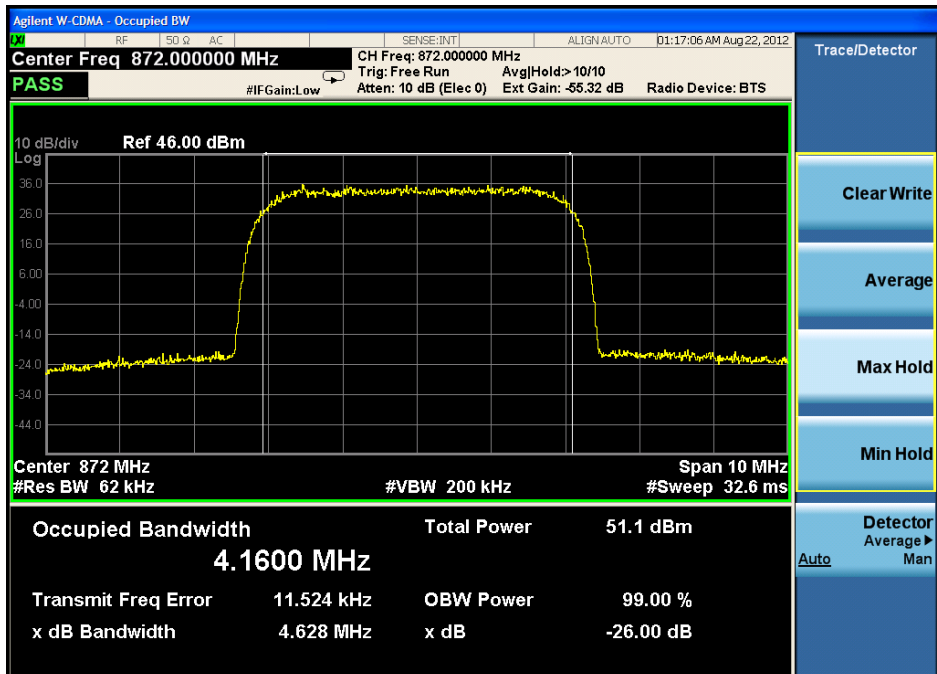



2.3.3 middle frequency-- Input

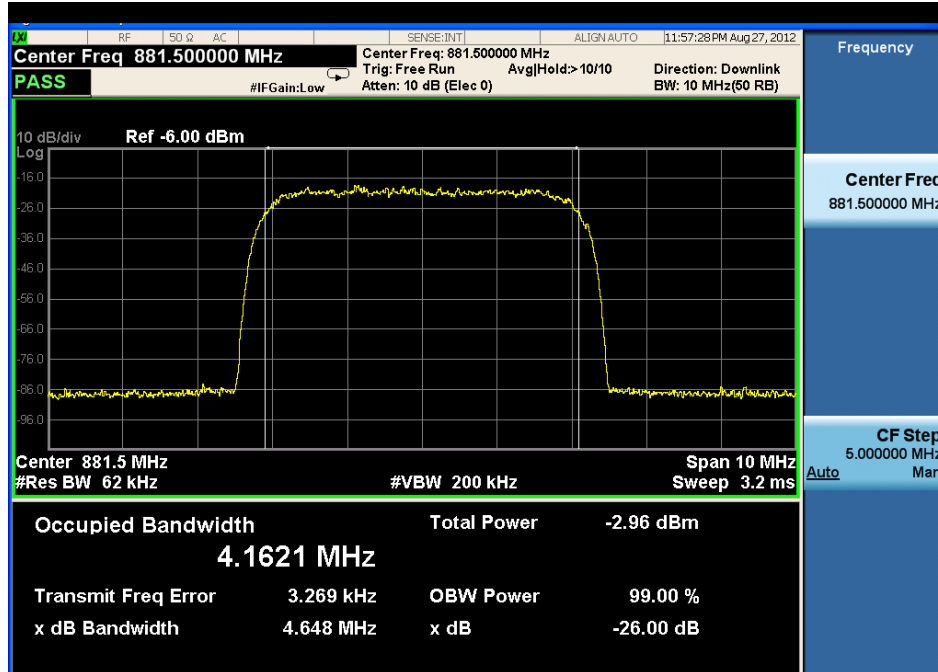

2.3.4 middle frequency-- Output

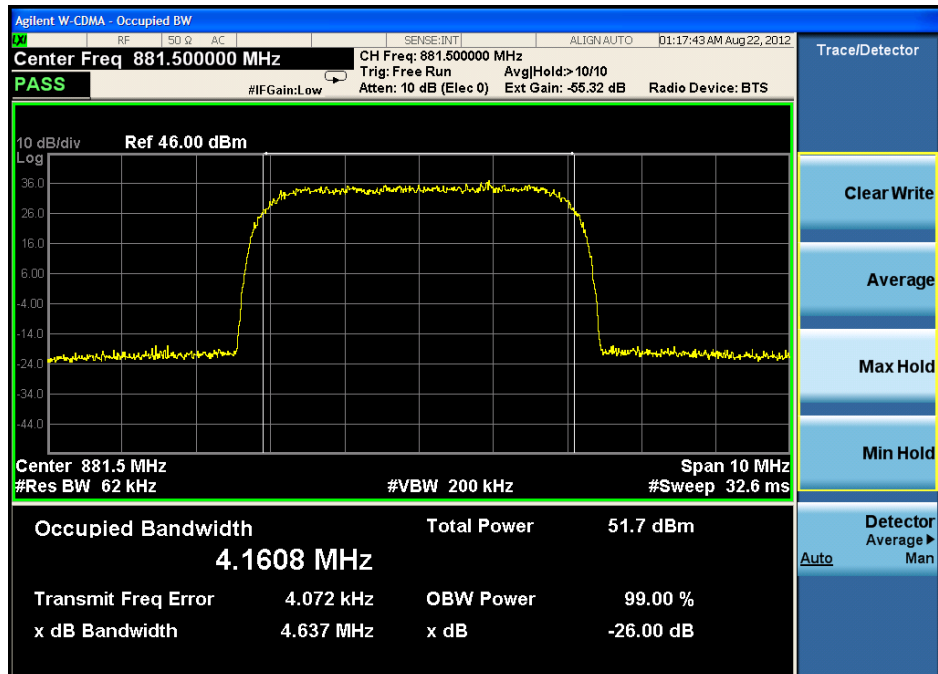



2.3.5 highest frequency—Input

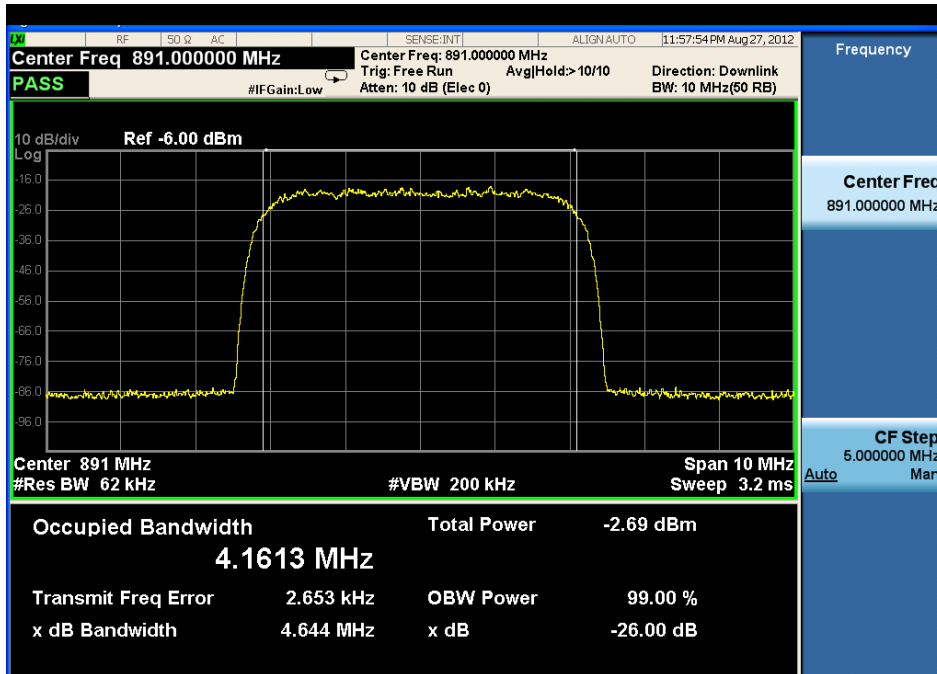

2.3.6 highest frequency--Output

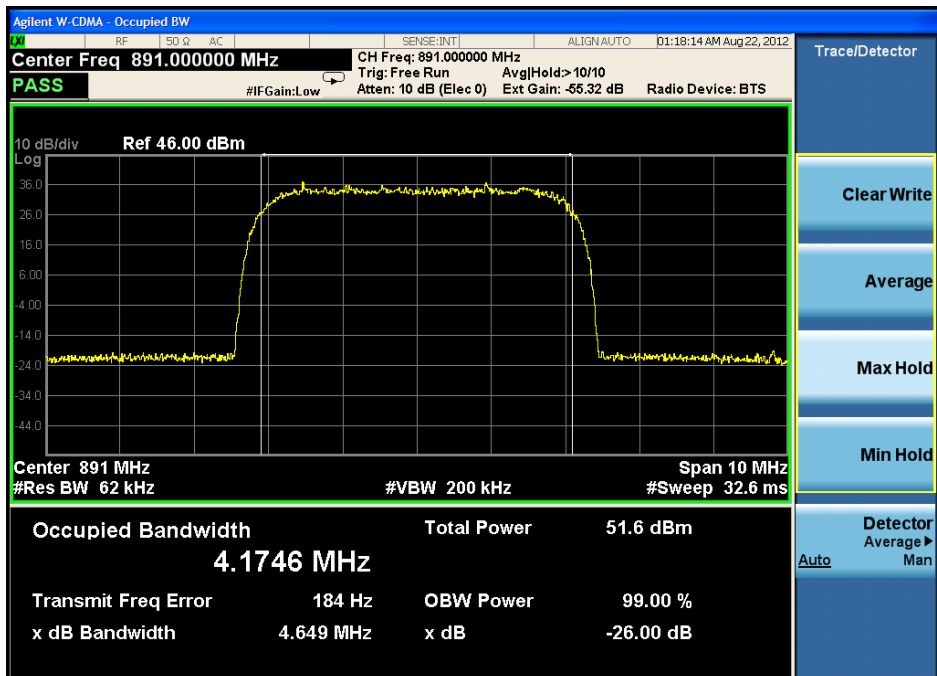



2.4 LTE Mode:

2.4.1 lowest frequency-- Input

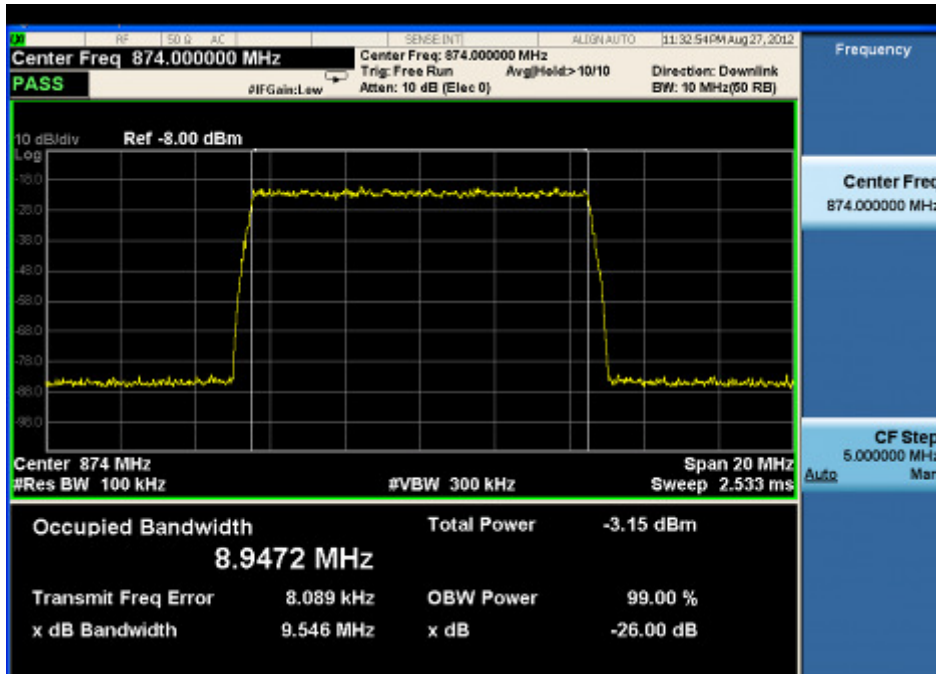

2.4.2 lowest frequency-- Output

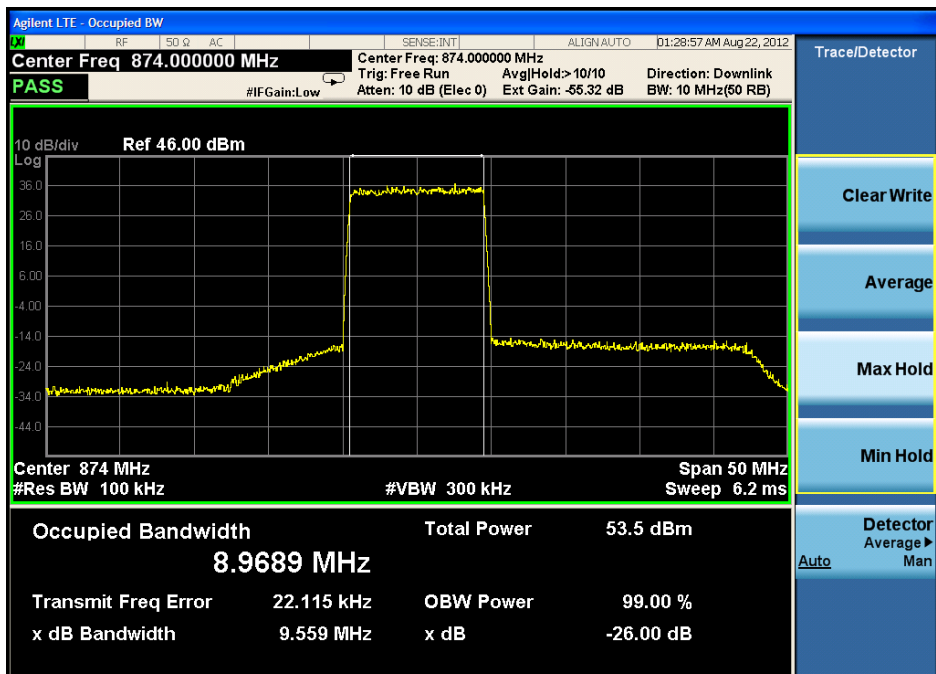

2.4.3 middle frequency-- Input

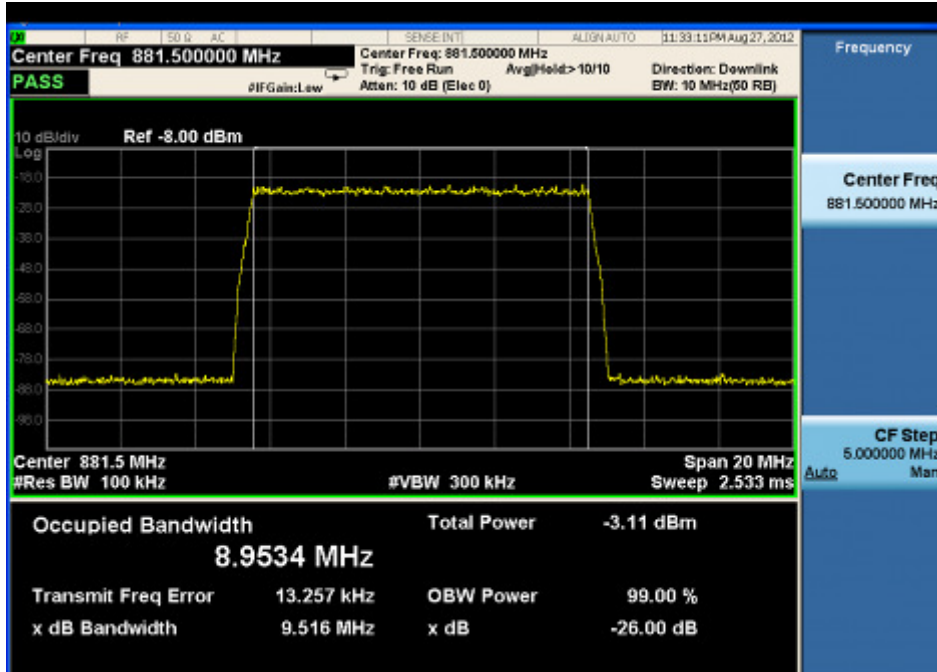

2.4.4 middle frequency-- Output

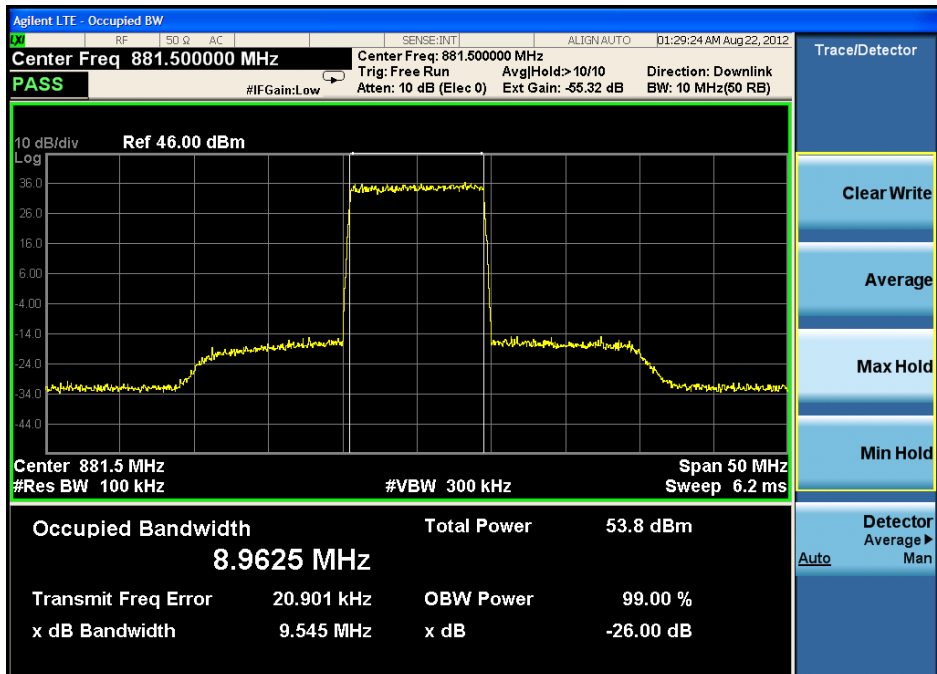



2.4.5 highest frequency—Input

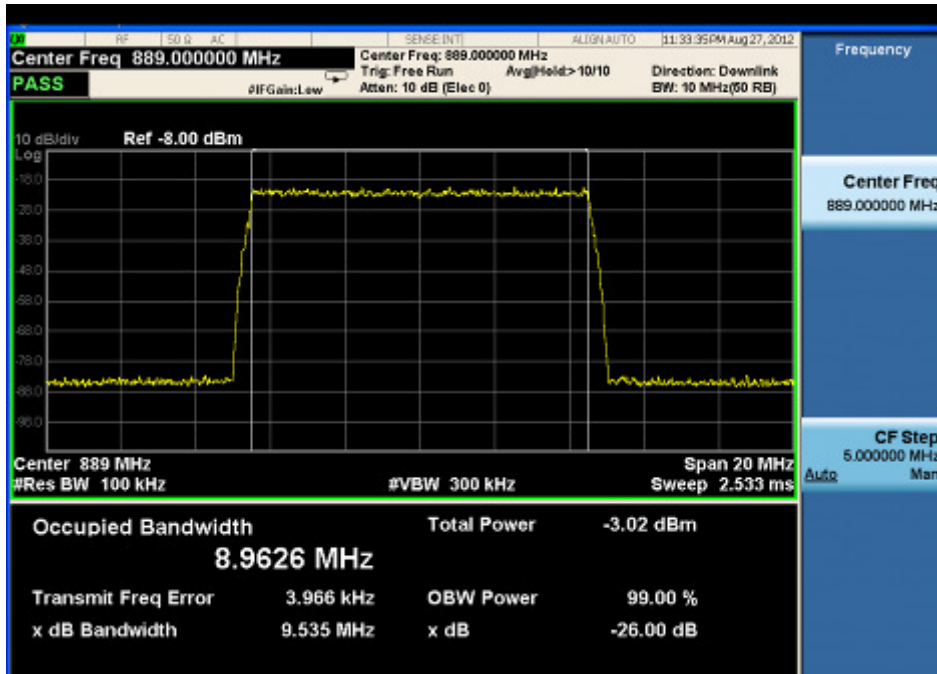

2.4.6 highest frequency--Output

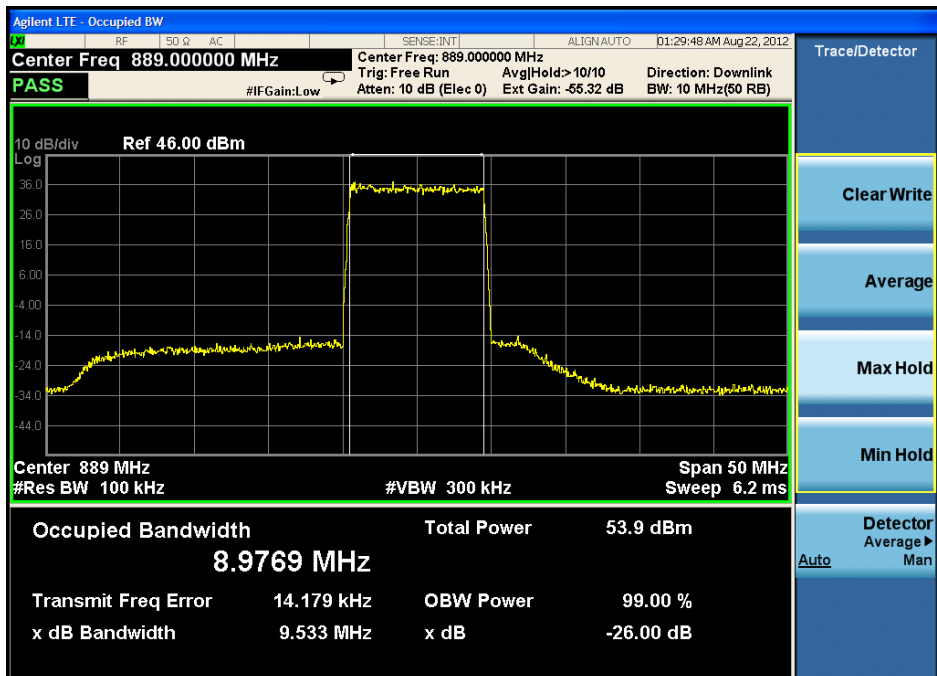



3. Downlink: 2110MHz to 2155MHz(CDMA,WCDMA,LTE)

3.1 CDMA Mode:

3.1.1 lowest frequency-- Input

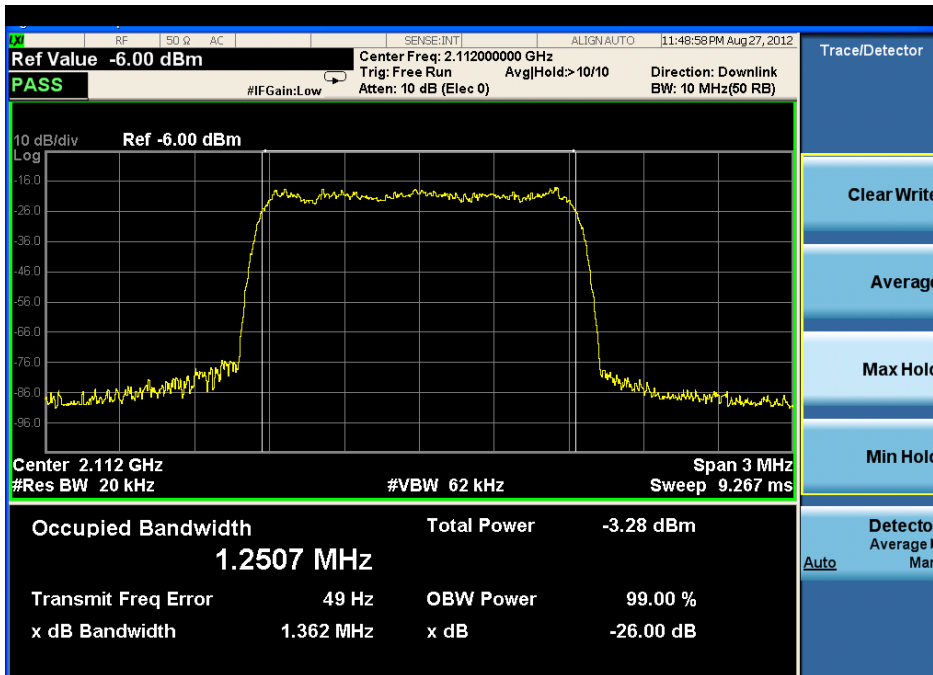

3.1.2 lowest frequency-- Output

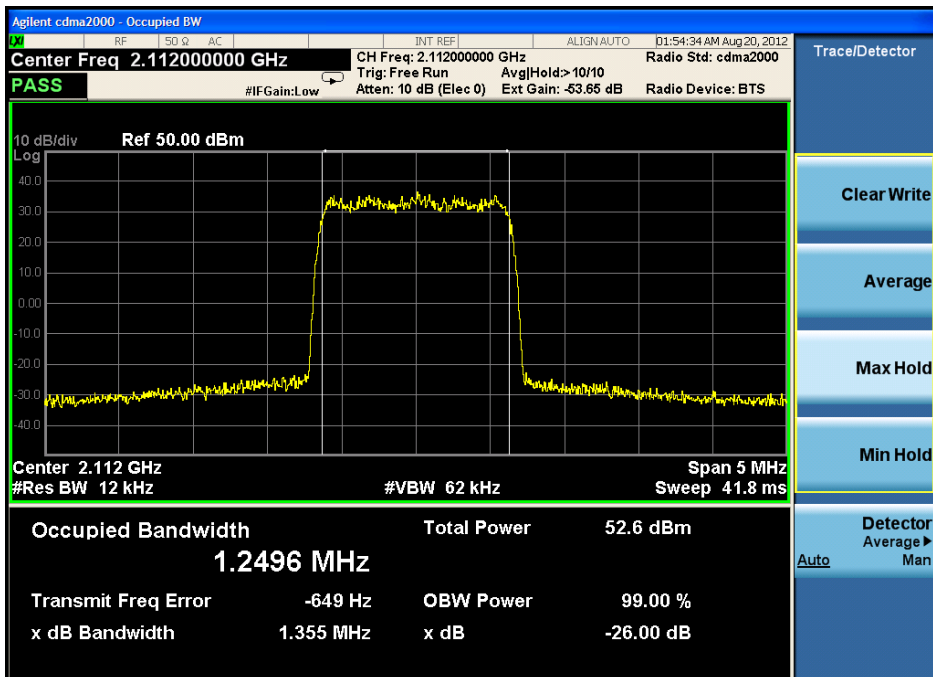



3.1.3 middle frequency-- Input

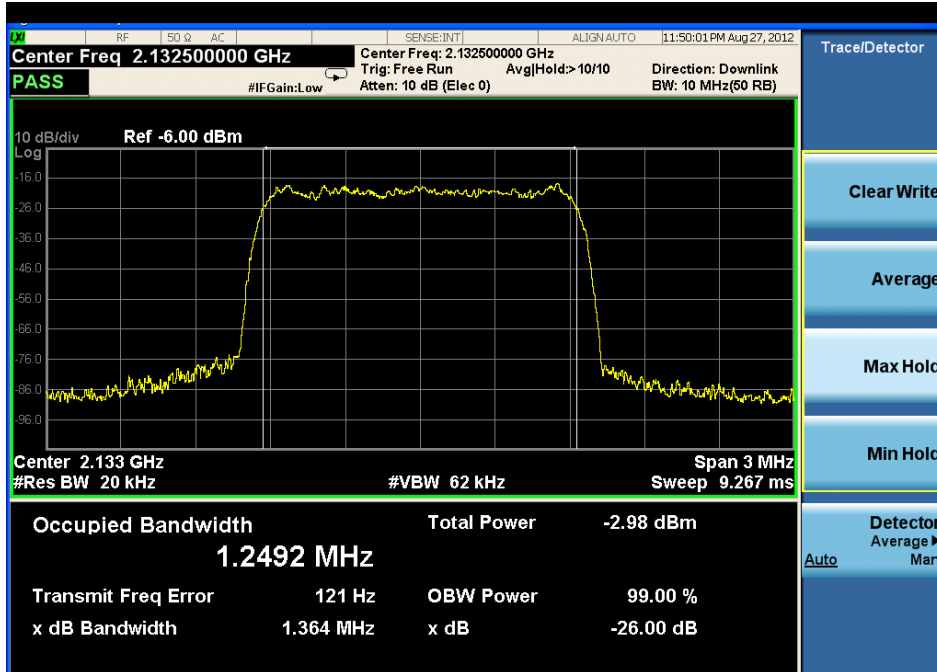

3.1.4 middle frequency-- Output

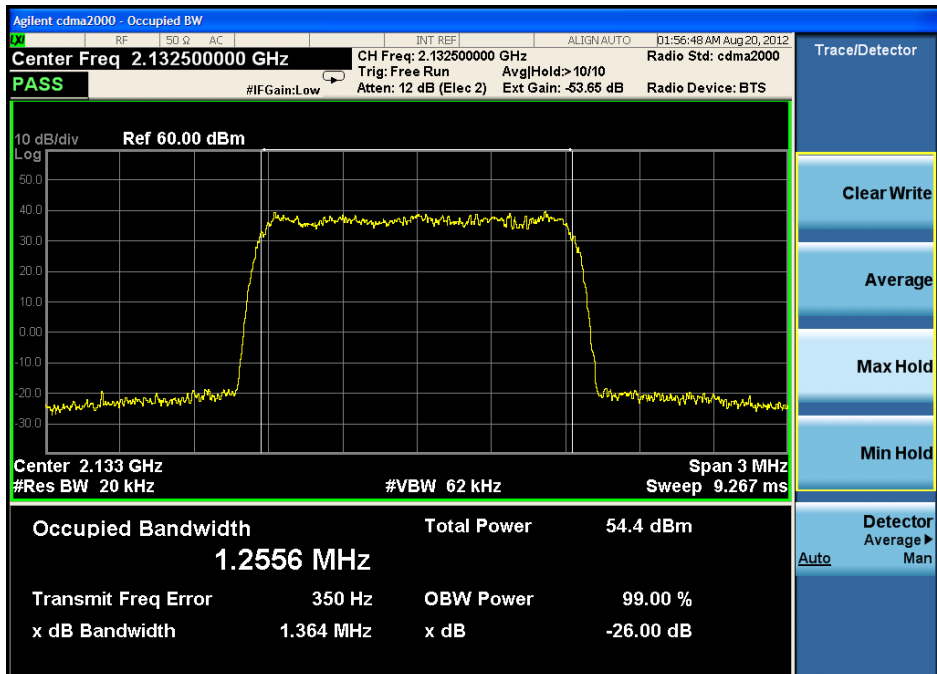



3.1.5 highest frequency—Input

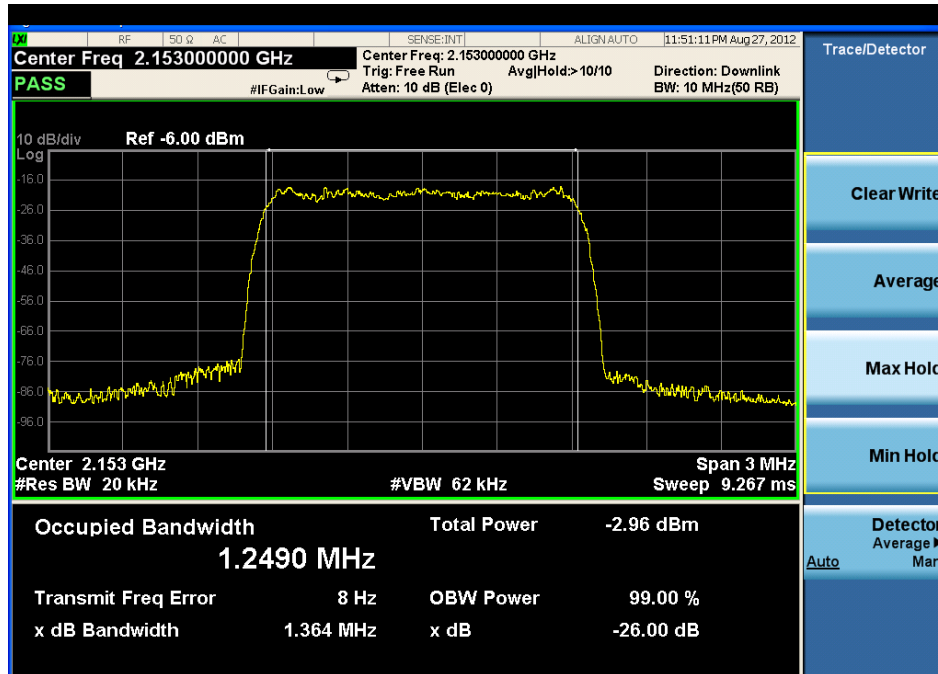

3.1.6 highest frequency--Output

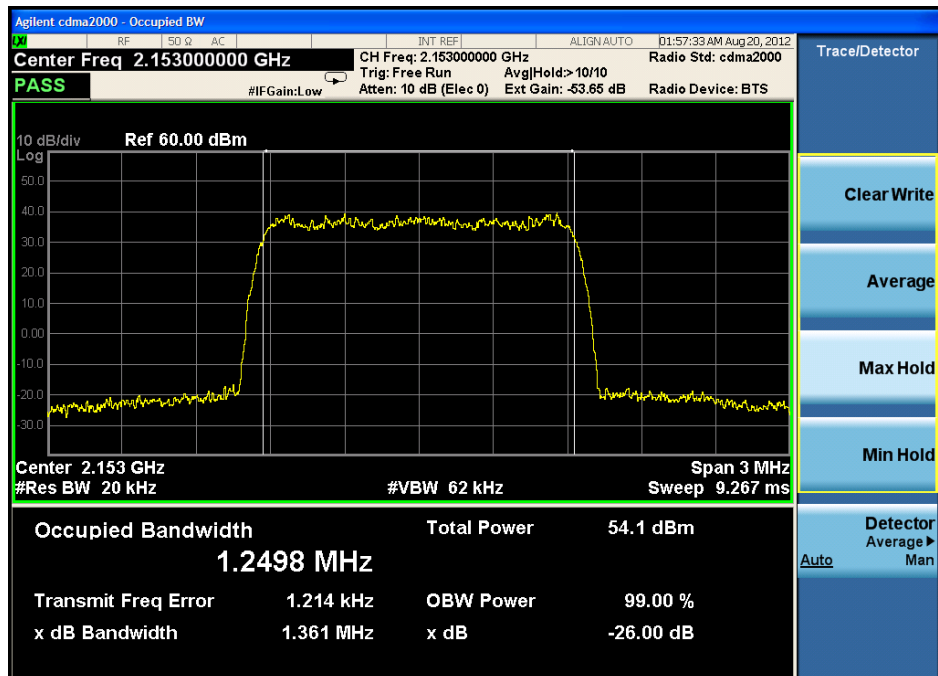



3.2 WCDMA Mode:

3.2.1 lowest frequency-- Input

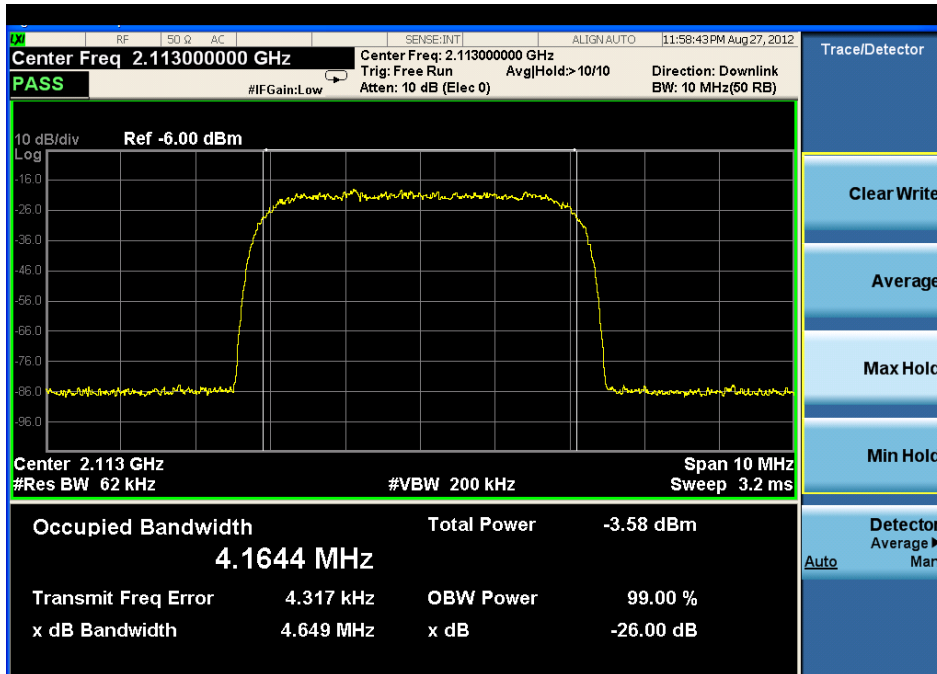

3.2.2 lowest frequency-- Output

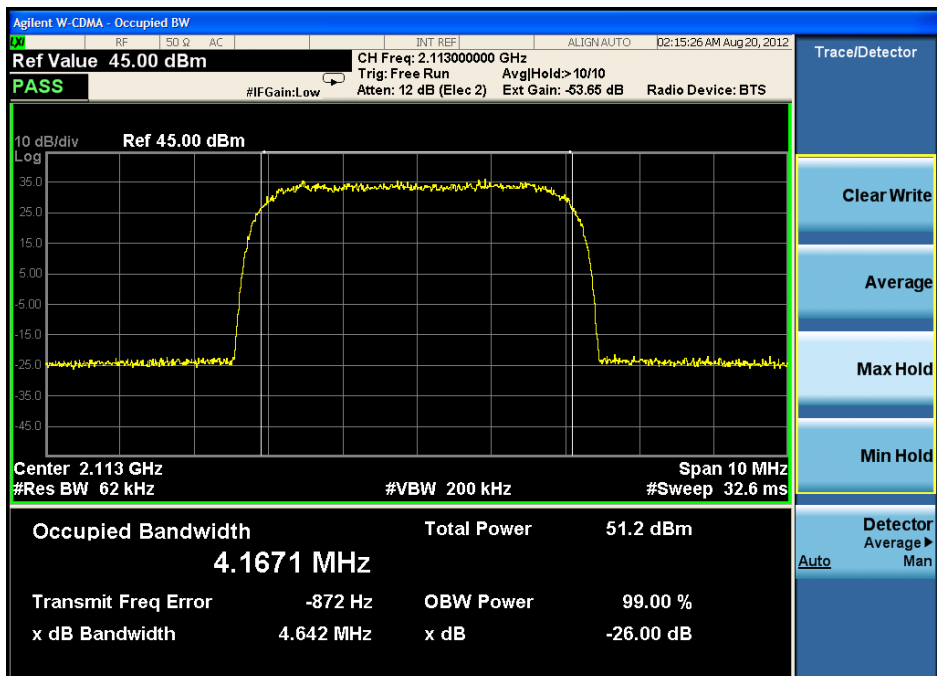



3.2.3 middle frequency-- Input

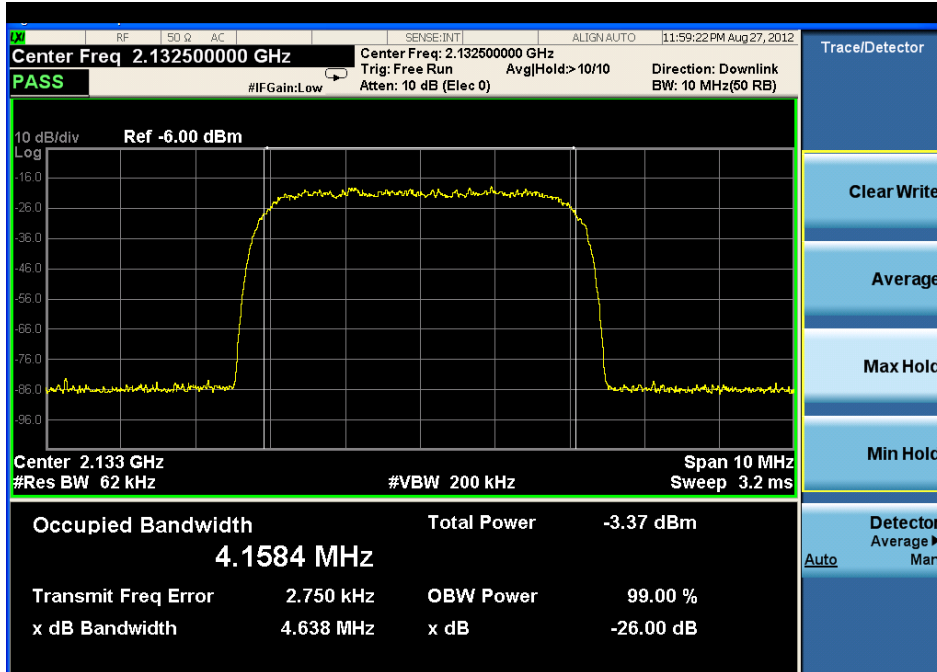

3.2.4 middle frequency-- Output

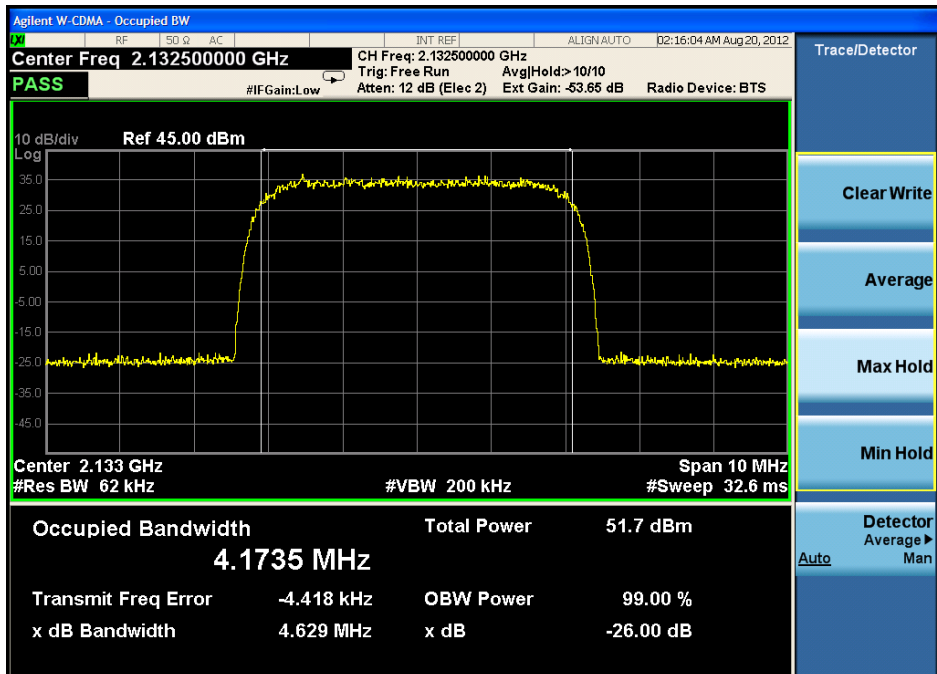



3.2.5 highest frequency—Input

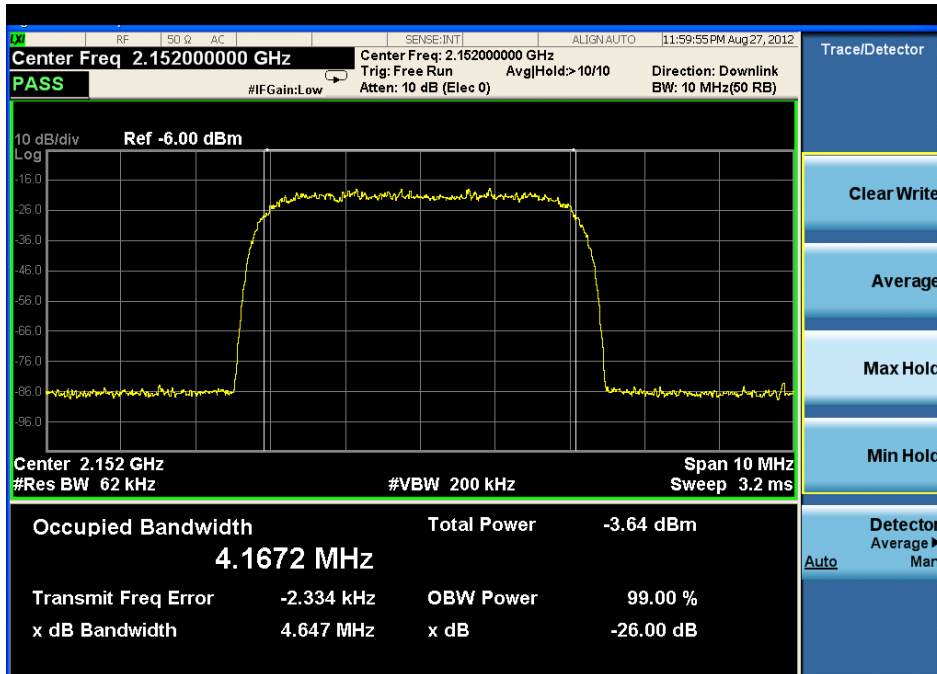

3.2.6 highest frequency--Output

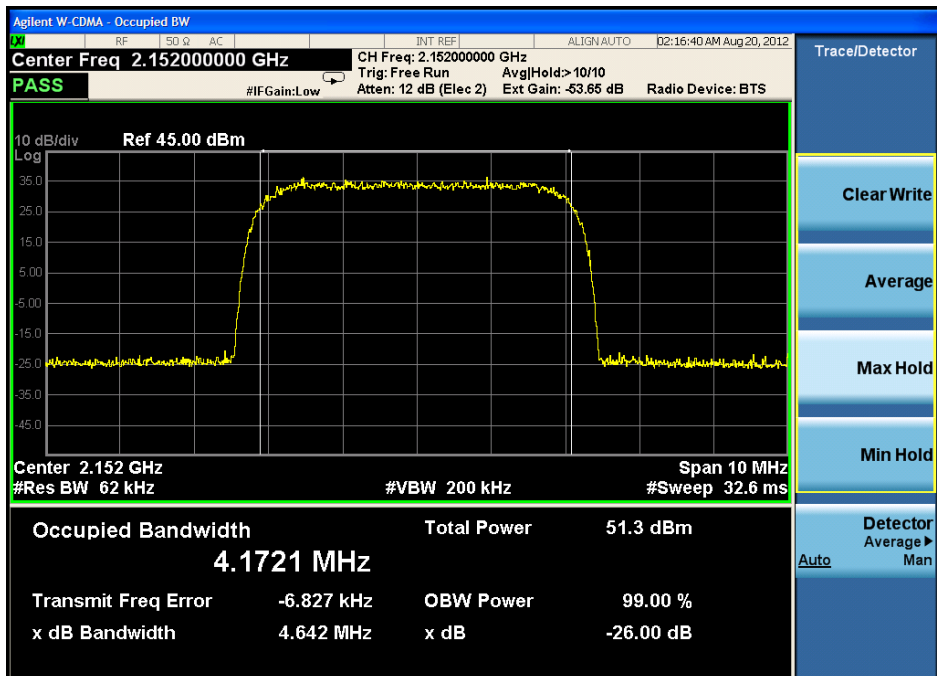



3.3 LTEMode:

3.3.1 lowest frequency-- Input

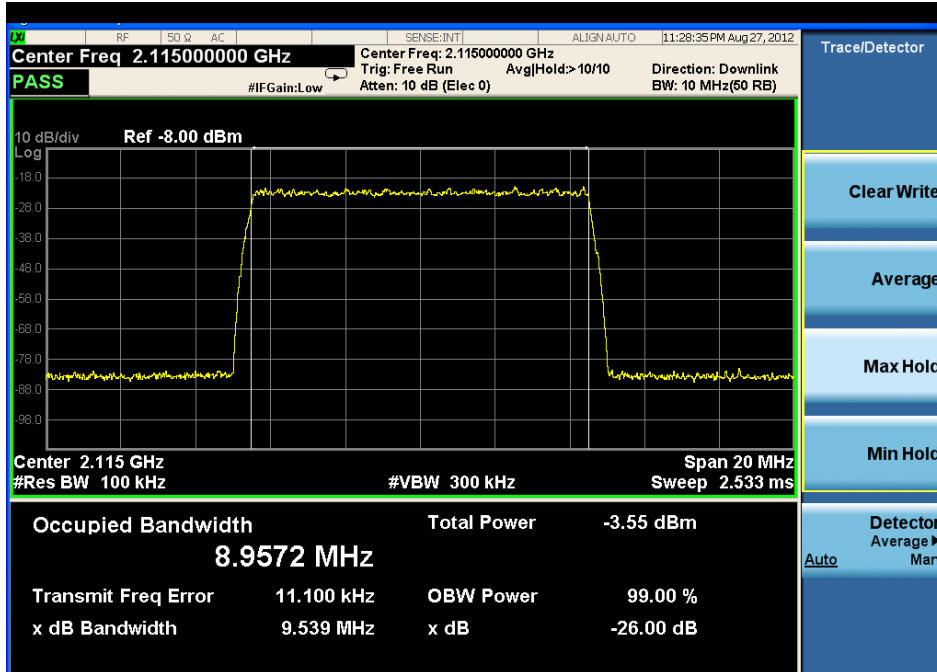

3.3.2 lowest frequency-- Output

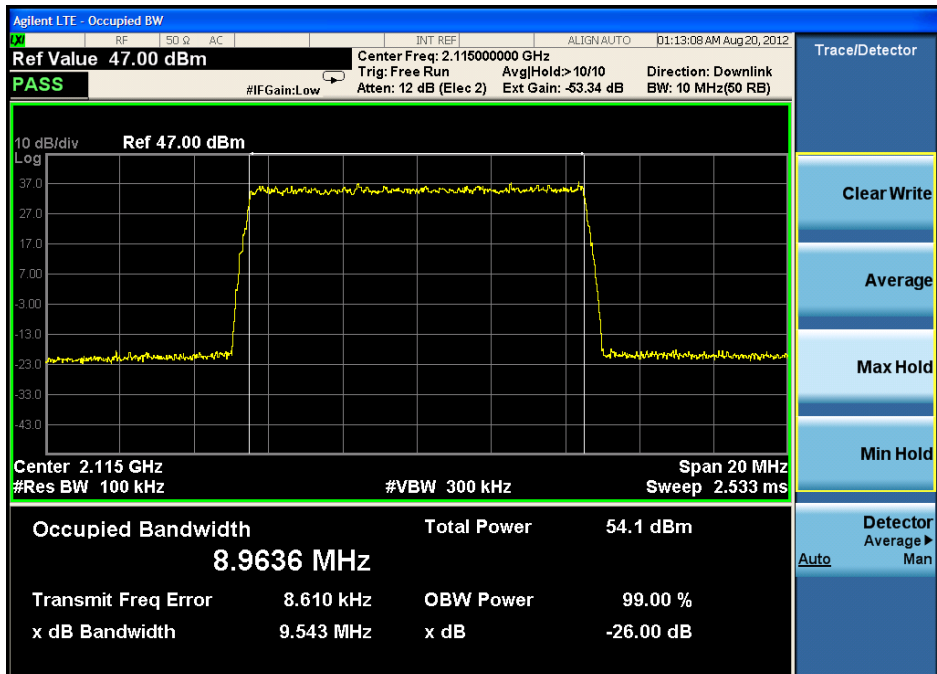

3.3.3 middle frequency-- Input

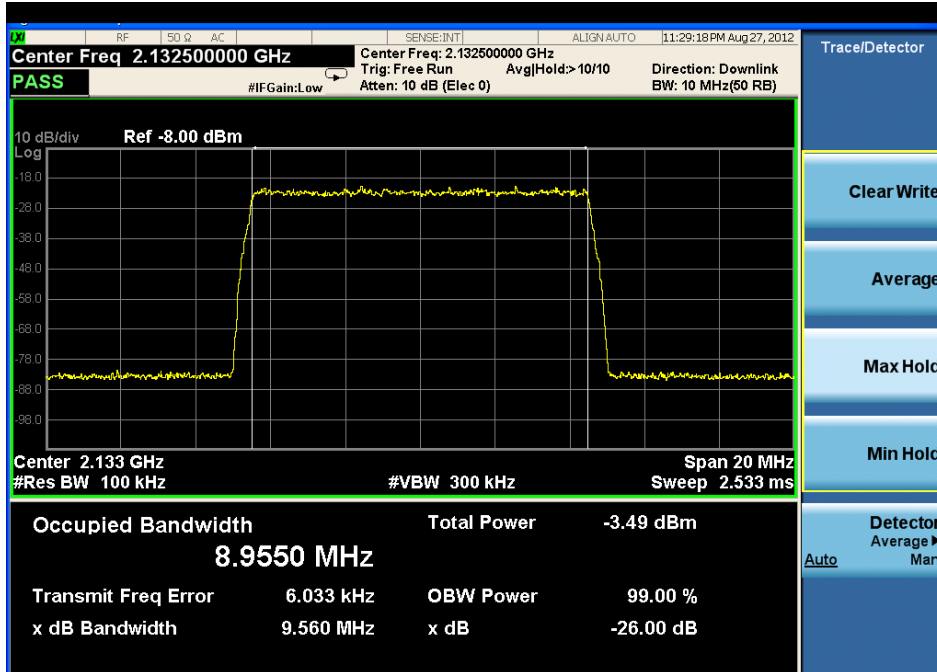

3.3.4 middle frequency-- Output

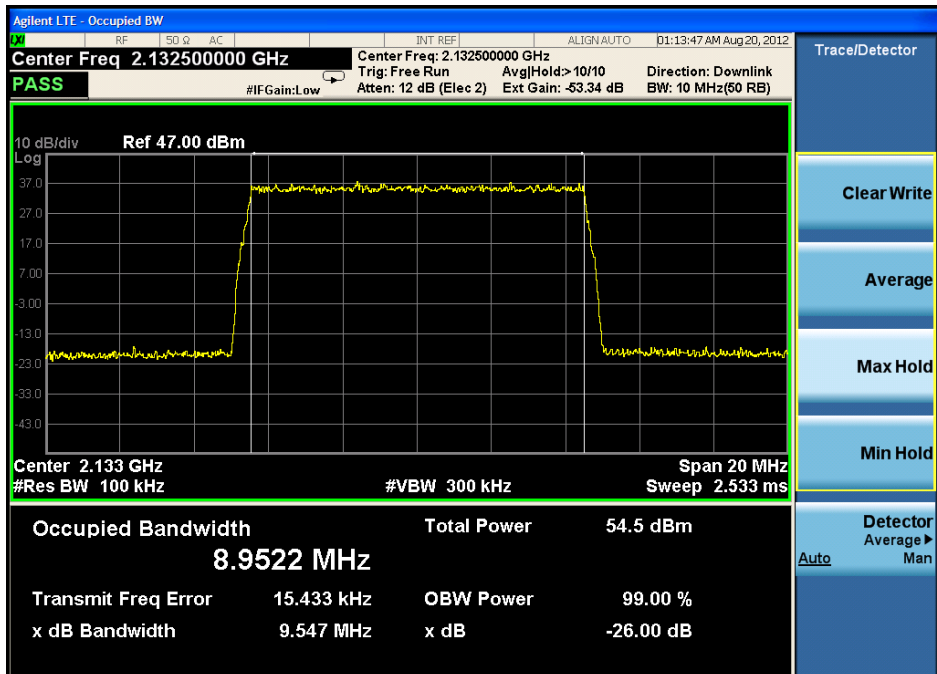



3.3.5 highest frequency—Input

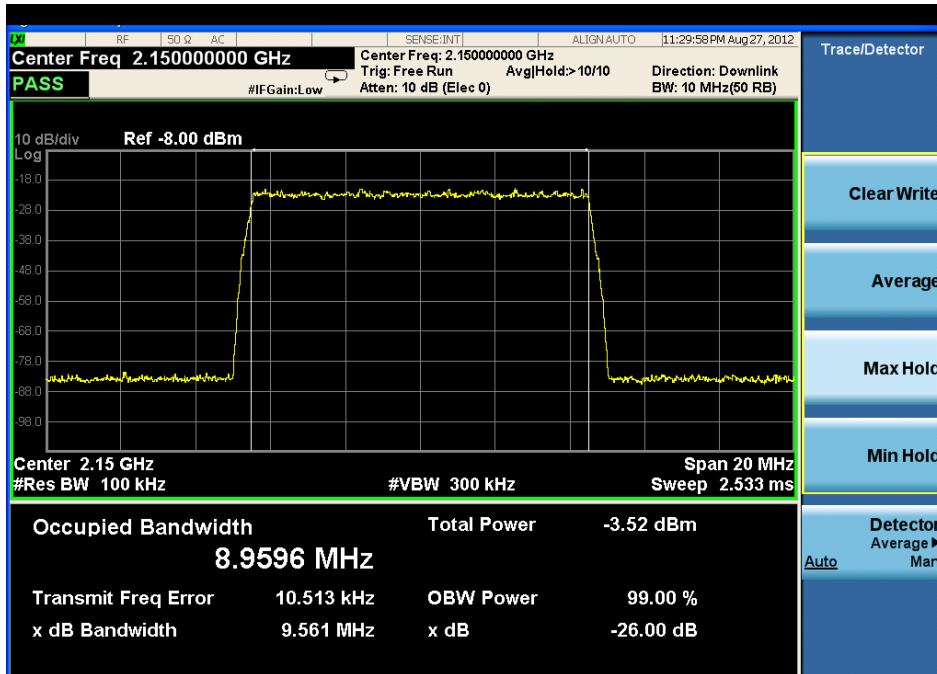

3.3.6 highest frequency--Output

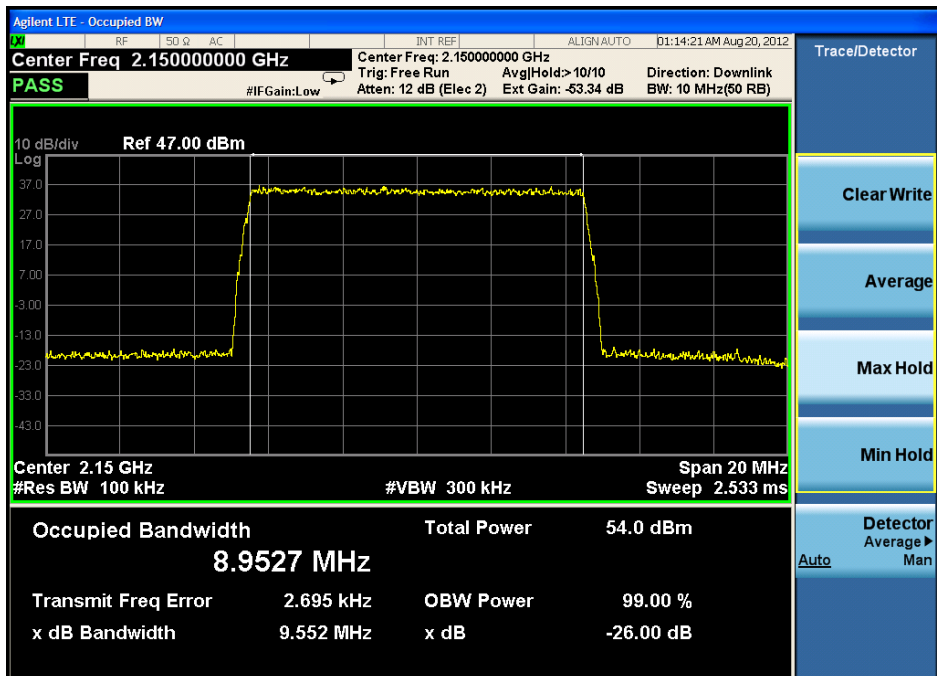

7.2.6 Out of Band Rejection

Test Date: 2012-08-20

Test Requirement: 2-11-04/EAB/RF

Test for rejection of out of band signals. Filter freq. response plots are acceptable.

Test Method: 2-11-04/EAB/RF

EUT Operation:

Status: Drive the EUT to maximum output power. .

Conditions: Normal conditions

Application: Cellular Band RF output ports

Test Configuration:

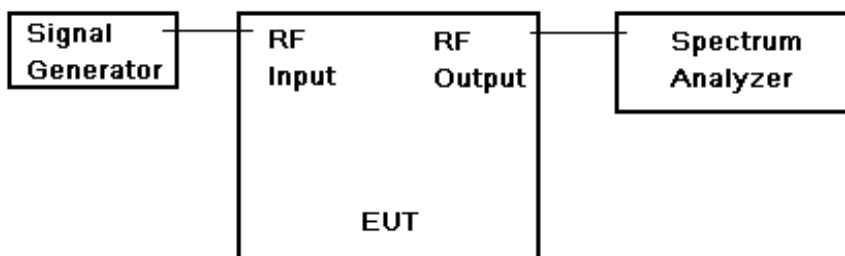

Fig.4. Out of Band rejection test configuration

Test Procedure:

1. Connect the equipment as illustrated;
 2. Test the background noise level with all the test facilities;
 3. Keep one transmitting path, all other connectors shall be connected by normal power or RF leads;
 4. Select the attenuator to avoid the test receiver or spectrum analyzer being destroyed;
 5. Keep the EUT continuously transmitting in max power;
 6. Signal generator sweep from the frequency more lower than the product frequency to the frequency more higher than it, find the product band filter characteristic;
- CW signal rather than typical signal is acceptable (for FM).
 - Multiple band filter will need test each other.



7.2.6.1 Measurement Record:

1.Test for Downlink: 728MHz to 757MHz

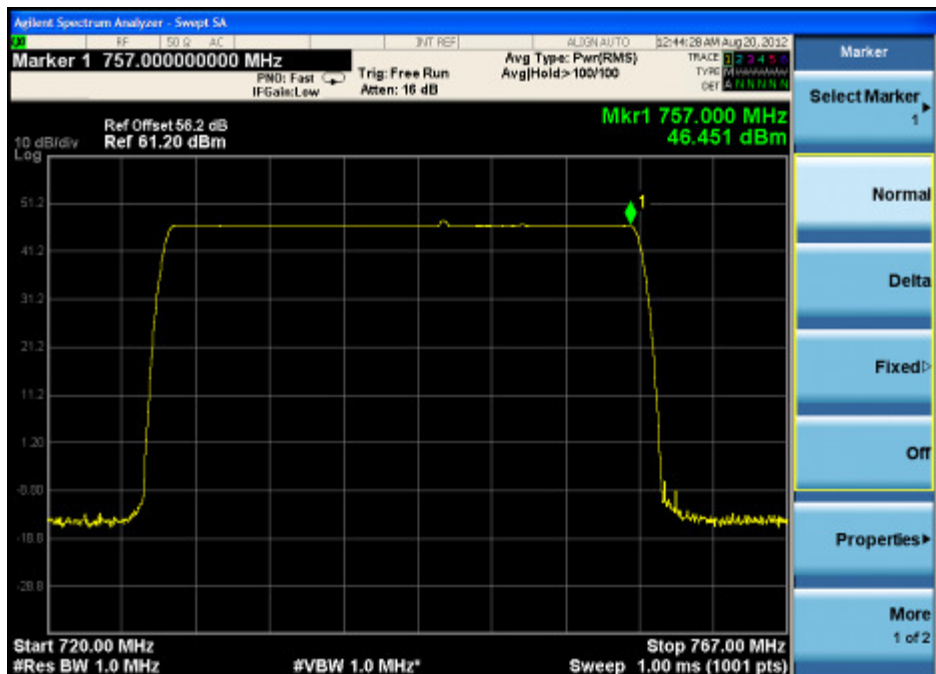
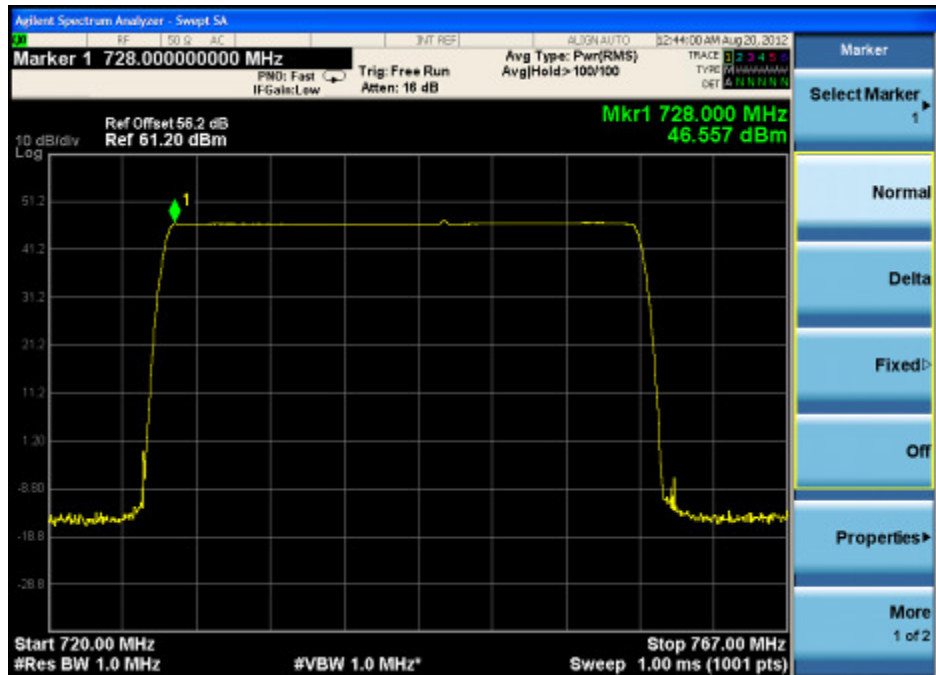



2. Test for Downlink: 869MHz to 894MHz

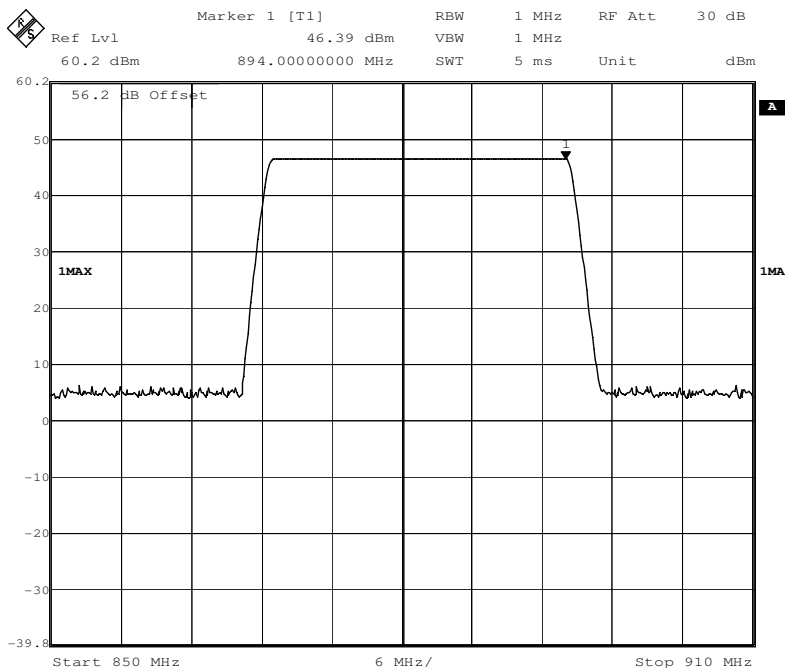
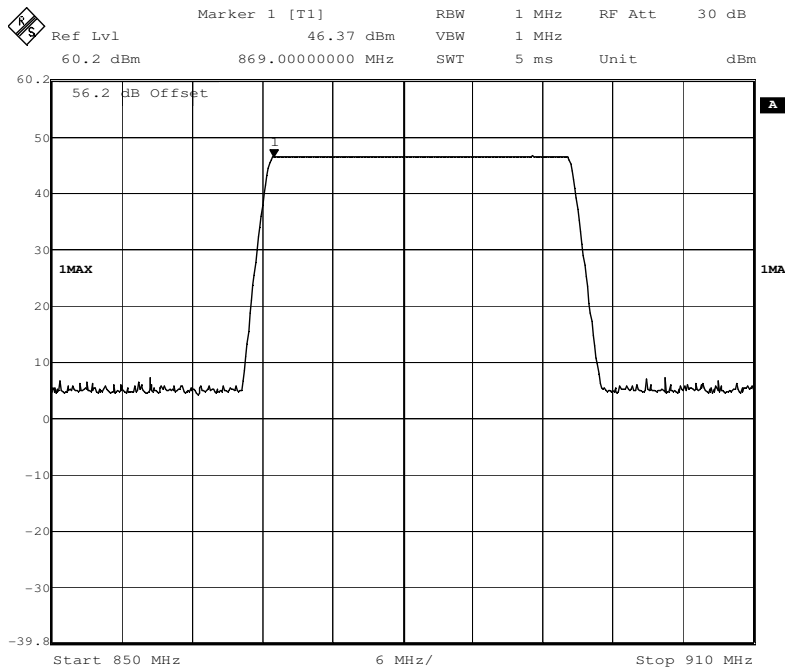



3. Test for Downlink:2110MHz to 2155MHz

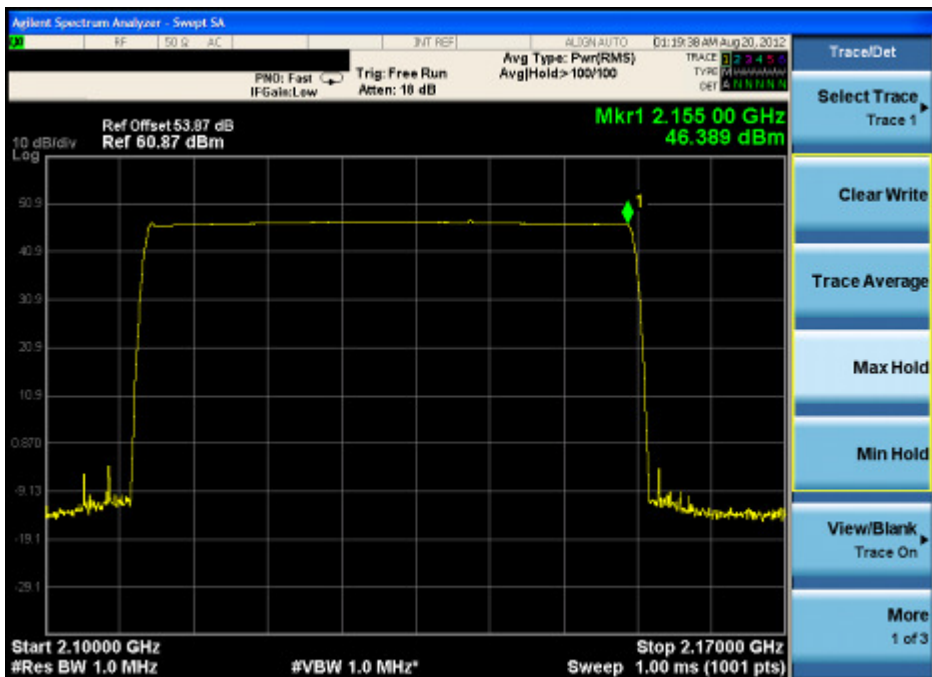
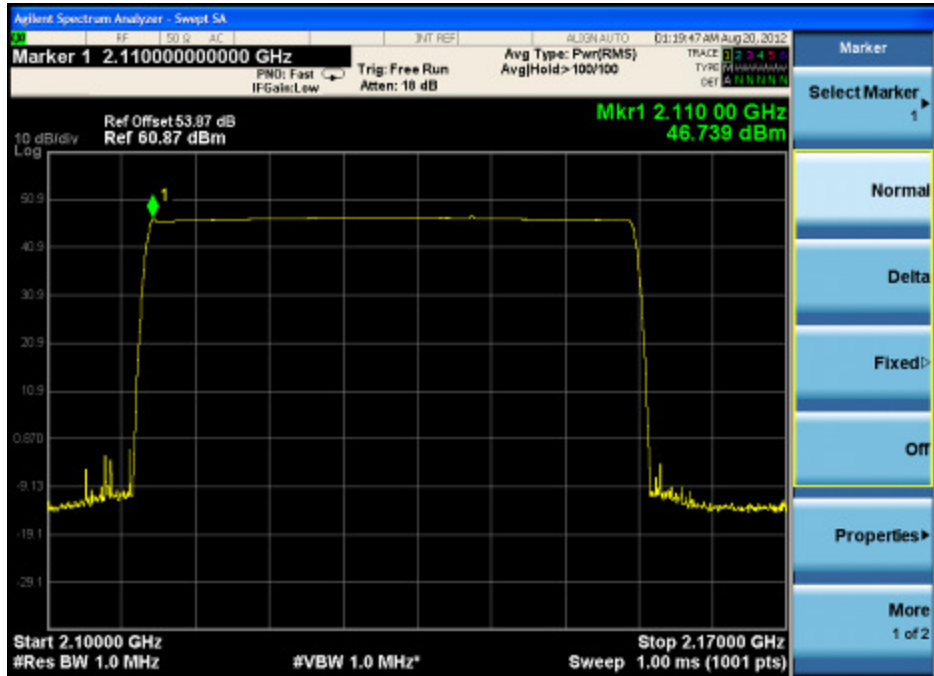



7.2.7 Frequency Stability

Test Date: 2012-08-29

Test Requirement: FCC part 22.355 & FCC part 27.54

The frequency stability shall be sufficient to ensure that the fundamental emissions stay within the authorized bands of operation.

Test Method: FCC part 2.1055

EUT Operation:

Status: Drive the EUT to maximum output power.

Conditions: Temperature conditions, voltage conditions

Application: Cellular Band RF output ports

Test Procedure:

1. Temperature conditions:

- a) The RF output port of the EUT was connected to Frequency Meter;
- b) Set the working Frequency in the middle channel;
- c) record the 20°C and nominal voltage frequency value as reference point;
- d) vary the temperature from -40°C to 50°C with step 10°C
- e) when reach a temperature point, keep the temperature balance at least 1 hour to make the product working in this status;
- f) read the frequency at the relative temperature.

2. Voltage conditions:

- a) record the 20°C and nominal voltage frequency value as reference point;
- b) vary the voltage from -15% nominal voltage to +15% voltage;
- c) read the frequency at the relative voltage.



7.2.7.1 Measurement Record:

Frequency Stability vs temperature:

1.Test for Downlink: 728~757MHz (middle channel 742.5MHz)

Temperature(°C)	Frequency(MHz)	Tolerance(ppm)
50	742.5000032	0.00188552
40	742.5000025	0.00094276
30	742.5000024	0.00080808
20	742.5000018	Reference
10	742.5000021	0.00040404
0	742.5000023	0.00067340
-10	742.5000016	0.00026936
-20	742.5000036	0.00242424
-30	742.5000031	0.00175084
-40	742.5000027	0.00121212

2.Test for Downlink: 869~894MHz (middle channel 881.5MHz)

Temperature(°C)	Frequency(MHz)	Tolerance(ppm)
50	881.5000042	0.00102099
40	881.5000039	0.00068066
30	881.5000035	0.00022689
20	881.5000033	Reference
10	881.5000029	0.00045377
0	881.5000032	0.00011344
-10	881.5000043	0.00113443
-20	881.5000037	0.00045377
-30	881.5000048	0.00170164
-40	881.5000045	0.00136132

3.Test for Downlink: 2110~2155MHz (middle channel 2132.5MHz)

Temperature(°C)	Frequency(MHz)	Tolerance(ppm)
50	2132.5000038	0.00046893
40	2132.5000034	0.00028136
30	2132.5000042	0.00065651
20	2132.5000028	Reference
10	2132.5000027	0.00004689
0	2132.5000034	0.00028136
-10	2132.5000038	0.00046893
-20	2132.5000047	0.00089097
-30	2132.5000042	0.00065651
-40	2132.5000029	0.00004689



Frequency Stability vs voltage:

4. Test for Downlink: 728~757MHz (middle channel 742.5MHz)

Voltage(V AC)	Frequency(MHz)	Tolerance(ppm)
102 (120*0.85)	742.5000023	0.00067340
120	742.5000018	Reference
138 (120*1.15)	742.5000034	0.00215488

5. Test for Downlink: 869~894MHz (middle channel 881.5MHz)

Voltage(V AC)	Frequency(MHz)	Tolerance(ppm)
102 (120*0.85)	881.5000029	0.00045377
120	881.5000033	Reference
138 (120*1.15)	881.5000028	0.00056722

6. Test for Downlink: 2110~2155MHz (middle channel 2132.5MHz)

Voltage(V AC)	Frequency(MHz)	Tolerance(ppm)
102 (120*0.85)	2132.5000031	0.0001407
120	2132.5000028	Reference
138 (120*1.15)	2132.5000027	0.0000469

--The End of Report--