

CORNING

Everon 6200

A3-E3-N3 Specification Sheet



Features	
1200MHz Transmission Bandwidth over 1 fiber	8 x 3GPP Band per Remote
Sub 6GHz	Up to 200MHz IBW
Dry contact Alarm	25dBm Maximum Output Power per Band
Support Band or Channel Selective filter	Cascading up to 6 levels

E62-A3 - Access Unit Chassis



The E62-A3 – Access Unit Chassis is a standard 19-inch 2U rack-mounted shelf (1U fan unit included), which serves as the host for Everon™ 6200. The E62-A3 provides coupling access to radio signal sources of multi-operator, multi-system, and multi-band, forming digital optical signals and distributing static capacity distribution to fiber-connected other type devices. One A3 supports up to eight optical interfaces connected to E3s (Expansion Unit) or N3RUs (Remote Unit).

This document describes the installation procedure for the E62-N3 remote unit.

This is NOT a CONSUMER device. It is designed for installation by FCC LICENSEES and QUALIFIED INSTALLERS. You MUST have an FCC LICENSE or express consent of an FCC License to operate this device. NOTE: Only authorized person can enter the area where the antenna is installed. And the person is fully aware of the potential for exposure and can exercise control over his or her exposure by leaving the area or by some other appropriate means. Awareness of the potential for RF exposure in a workplace or similar environment can be provided through specific training as part of a RF safety program.

E62-AU-AC – Active Combiner Module



The E62-AU-AC – Active Combiner Module is the interface to the operator base station signal source equipment. Each module has four QMA ports for signal input from the maximum four operators. One Access Unit can be equipped with up to four modules. In accordance with wireless service provider standards, it is not advised to use digital repeaters as a signal source for Corning solutions.

E62-E3-O - Expansion Unit



The E62-E3-O – Expansion Unit is a standard 19-inch 1U rack-mounted shelf, which serves as the interface between the Primary A3 and the Remote Unit for the capacity expansion of system.

E62-N3RU – Low Power Remote Unit



The E62-N3RU is a low-power remote unit supporting cellular technologies on fiber optic cable using the CPRI protocol. The N3 is ideal for multi-operator multi-band, static capacity distribution deployments of cellular services in small-to-medium coverage areas. The N3 supports up to four 25 dBm RF channels. The N3 converts an optical signal to RF and then transmits at the relevant 3GPP band and receives the analog RF signal, conditions it, and converts it back to optical for routing to the E3 or A3.

The socket-outlet shall be easily accessible.

Please take attention that changes or modification not expressly approved by the party responsible for compliance could void the user’s authority to operate the equipment.

This device complies with Part 15 of the FCC Rules. Operation is subject to the following two conditions:
 (1) This device may not cause harmful interference, and
 (2) This device must accept any interference received, including interference that may cause undesired operation.

This equipment complies with FCC radiation exposure limits set forth for an uncontrolled environment. This equipment should be installed and operated with minimum distance 20cm between the radiator & your body.

Specifications

E62-A3 - Access Unit Chassis

Supported Bands				
Band	3GPP Band	Downlink	Uplink	Max IBW
600MHz	71	617-652	663-698	35
700 LU	12 & 13	729-756	699-716 & 777-787	27
700MHz LUPS	12 & 13 & 14	728-768	698-716 & 776-798	40
850E MHz	26	859-894	814-849	35
1900MHz	25	1930-1995	1850-1915	65
2100MHz	66E	2110-2200	1710-1780	90
2300MHz	30	2350-2360	2305-2315	10
2500MHz TDD	41	2496-2690	2496-2690	194
C-Band-1	n78	3450-3800	3450-3800	200

C-Band-2	n77	3700-3980	3700-3980	200
----------	-----	-----------	-----------	-----

Interface

Access Unit RF Interface	QMA Female
Optical Connector Type	8 x 25 GBps SFP+ Interfaces 6 to 8 optical connections to E3-O or N3 2 optical connections to Secondary A3s
Transmission Rate	25 GB/s
AU-AC modules	4 x AU-AC modules per chassis (RF interface with BTS) Full 3GPP Band per Module (up to 200 MHz)
Band Support	12x 3GPP bands over 1 fiber core (using 2 x Secondary A3)
Dry contact Alarms	1x RJ45 (2x in, 2x out)
Maintenance Interface	Ethernet RJ45
AU-AC power level (dB)	0dBm to +15 dBm Input Power Range for each port

Electrical

Electromagnetic Compatibility/Interference (EMC/EMI)	3GPP TS38.113
Maximum Power Consumption	85W
AC Power	100-240v AC, 50/60Hz
DC Power	48VDC ± 20%

Environmental

Mean Time Between Failure (MTBF)	> 220,000 hours
Operating Temperature	-10°C to +45°C
Storage Temperature	-40°C to +85°C
Humidity	0% to 90% (Noncondensing)
Cooling	Active
Installation	Wall or 19-in Rack
Ingress Protection Rating	IP30 (Indoor)

Mechanical

AU (Width / Height / Depth / Weight)	440mm / 88mm / 329mm / 8.0kg 17.32in / 3.46in / 12.95in / 17.64lb
--------------------------------------	--

E62-E3-O - Expansion Unit

Interface

Optical Connector Type	16 x 25 GBps SFP+ Interfaces 14x optical connections to N3RU 1x optical connection to Primary A3 or upper level E3 1x optical connection to lower level E3
Transmission Rate	25 GB/s
Cascading	Up to 5 x E3-O per Optical connection
Dry contact Alarms	1x RJ45 (2x in, 2x out)
Maintenance Interface	Ethernet RJ45

Electrical

Electromagnetic Compatibility/Interference (EMC/EMI)	3GPP TS38.113
Maximum Power Consumption	65 W
AC Power	100-240 VAC, 50/60 Hz
DC Power	48VDC ± 20%

Environmental

Mean Time Between Failure (MTBF)	> 220,000 hours
Operating Temperature	-10°C to +45°C
Storage Temperature	-40°C to +85°C
Humidity	0% to 90% (Noncondensing)
Cooling	Passive
Installation	Wall or 19-in Rack
Ingress Protection Rating	IP30 (Indoor)

Mechanical

E3-O (Width / Height / Depth / Weight)	440 mm / 44 mm / 220 mm / 6.0 kg 17.32 in / 1.73 in / 8.66 in / 13.23 lb
--	---

E62-N3RU – Low Power Remote Unit

System

Maximum RF Bands per Access Unit	4
Maximum RF Bands per Remote Unit	8
Maximum RF Bands per System	12
Maximum Access Units per System	3 (1 x Primary / 2 x Secondary)
Maximum E3s per Primary A3	8
Maximum E3s cascaded	5
Maximum N3s cascaded	6
Frequency Range	DL: 2110 MHz – 2200 MHz; UL: 1710 MHz – 1780 MHz
Bandwidth per Channel (Downlink & Uplink)	≤200 MHz (Contiguous)
Digital Bandwidth per Channel (Downlink & Uplink)	NR: 10/15/20/25/30/40/45 MHz
Bandwidth per System (Downlink & Uplink)	≤ 1200 MHz
MIMO	2x2 4x4
System Delay Adjustment	Up to 50.00 μs

Forward Path (Downlink)

Maximum Composite Output power	f >2.5GHz	25 dBm
	1.7GHz < f < 2.3GHz	23 dBm
	f < 1GHz	17 dBm
Output Power Accuracy	±2 dB	
Maximum Input Power	+15 dBm	
Ripple	4 dB peak to peak	
Error Vector Magnitude	<3.5% @ 256 QAM	
Manual Attenuation Control	30 dB @ 1 dB/step (A3:20 dB, N3RU:10 dB)	
System Delay (1A3+1E3+1N3)	12 μs	

Reverse Path (Uplink)

Maximum Output Power per Channel	-15dBm @ f >2.5GHz; -17dBm @ 1.7GHz < f < 2.3GHz; -23dBm @ f < 1GHz
Output Power Accuracy	±2 dB
Maximum Input Power	-25dBm
Ripple	4 dB peak to peak
Manual Gain Control	30dB @ 1dB/step (A3:20dB, N3RU:10dB)
Noise Figure (1A3+1E3+1N3)	10dB @ Maximum Gain
IIP3	-10dBm

Interface

Antenna Interface (All bands)	QMA Female (External Antenna version)
Transmission Connector Type	2 x 25 Gbps SFP+ Interfaces 1x optical connection to Primary A3, upper level E3 or N3

	1x optical connection to lower level N3
Transmission Rate	25 GB/s
Optical Fiber Length	10km
Cascading	Up to 5 x E3-O per Optical connection
Maintenance Interface	Ethernet RJ45

Electrical

Electromagnetic Compatibility/Interference (EMC/EMI)	3GPP TS38.113
Maximum Power Consumption	75 W
DC Power	48VDC \pm 20%

Environmental

Mean Time Between Failure (MTBF)	> 220,000 hours
Operating Temperature	-10°C to +45°C
Storage Temperature	-40°C to +85°C
Humidity	0% to 90% (Noncondensing)
Cooling	Passive
Installation	Ceiling or Wall
Ingress Protection Rating	IP30 (Indoor)

Mechanical

N3 (Width / Height / Depth / Weight)	310 mm / 83 mm / 310 mm / 4.5 kg
Integrated Antenna Version	12.20 in / 3.27 in / 12.20 in / 9.92lb
N3 (Width / Height / Depth / Weight)	310 mm / 83 mm / 310 mm / 4.5 kg
External Antenna Version	12.20 in / 3.27 in / 12.20 in / 9.92lb

Regulation

FCC, UL62368-1, UL 2043

System Topology

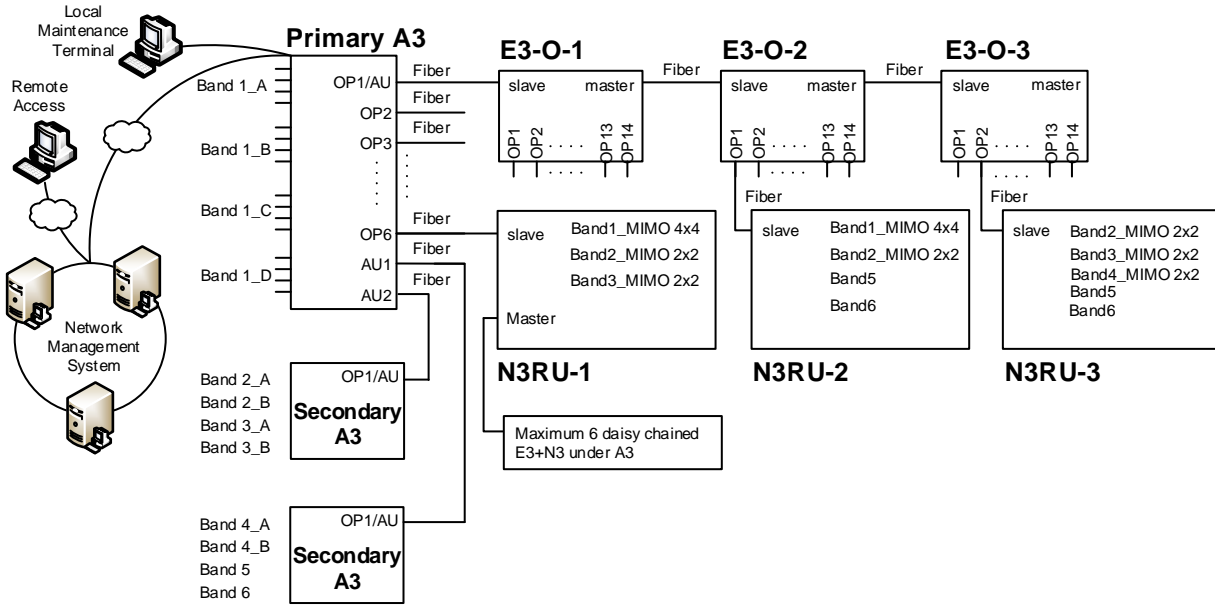



CORNING

Corning Optical Communications LLC • 4200 Corning Place • Charlotte, NC 28216 USA
800-743-2675 • FAX: 828-325-5060 • International: +1-828-901-5000 • www.corning.com/opcomm

Corning Optical Communications reserves the right to improve, enhance, and modify the features and specifications of Corning Optical Communications products without prior notification. A complete listing of the trademarks of Corning Optical Communications is available at www.corning.com/opcomm/trademarks. All other trademarks are the properties of their respective owners. Corning Optical Communications is ISO 9001 certified. © 2020 Corning Optical Communications. All rights reserved.