

The logo for Corning, consisting of the word "CORNING" in white, uppercase, sans-serif font, centered within a dark blue square.

High-Power (E62-H2) User Manual

Everon™ 6200

GENERAL INFORMATION

The E62-H2RU is a high-power remote unit supporting cellular technologies on fiber optic cable using the CPRI protocol. The H2 is ideal for multioperator multiband deployments of cellular services in large coverage areas. The H2 supports up to 43 dBm output per band in single 2T2R or dual 1T1R up to 80 MHz per band. The H2 converts an optical signal to RF and then transmits at the relevant 3GPP band and receives the analog RF signal, conditions it, and converts it back to optical for routing to the E2 or A2.

This document describes the installation procedure for the E62-H2 unit.

This is NOT a CONSUMER device. It is designed for installation by FCC LICENSEES and QUALIFIED INSTALLERS. You MUST have an FCC LICENSE or express consent of an FCC License to operate this device. NOTE: Only authorized person can enter the area where the antenna is installed. And the person is fully aware of the potential for exposure and can exercise control over his or her exposure by leaving the area or by some other appropriate means. Awareness of the potential for RF exposure in a workplace or similar environment can be provided through specific training as part of a RF safety program.

1. Content

Preface	4
Safety Instructions	4
Environmental Considerations	5
DC Power Connections	5
Warning Marks.....	7
Unpacking and Inspecting	8
Inspecting the Packing Container	8
Unpacking the Device	8
Verifying the Contents.....	8
Inspecting the Device	9
Installation Preparation.....	9
Site Investigation	9
Installation Tools	9
Torque Settings.....	9
Clearance	9
Installing the Access Unit (AU).....	11
Accessories List	11
Rack Installation	12
Fan Installation.....	16
Wall Installation	18
AU Mounting Dimension Spacing.....	21
RF Connection	22
Installing the Expansion Unit (EU-O).....	23
Accessories List	23
Rack Installation	24
Wall Installation	29
EU-O Mounting Dimension Spacing	32
Installing the High Power Remote Unit (H2RU)	33
Accessories List	33

Wall Installation (Back on the Wall)	34
Wall Installation (Side on the Wall)	39
Pole Installation.....	44
H2RU Mounting Dimension Spacing.....	45
Optical Connection	46
Optical Transceiver Module.....	46
Single Port Bidirectional SFP Transceiver	46
Dual Port SFP Transceiver	46
Optical Indicator	47
AU Optical Port Description	48
EU-O Optical Port Description	49
RU Optical Port Description.....	50

2. Preface

Safety Instructions

 All the following “Safety Precautions” must be observed during the entire installation and operation of the Everon 6200 system.

The Everon 6200 system components are designed for maximum safety and reliability when they are installed, used, and maintained by trained and qualified technicians in accordance with the procedures and instructions contained in this manual. To assure the safe operation of your system, always follow the safety and operational recommendations in this manual.

1. H2RU is not a consumer product. Please install and use H2RU in accordance with the instructions.
2. Before installing or modifying any H2RU equipment, read and fully understand the entire instructions in this guide.
3. Only qualified personnel are authorized to install and maintain the H2RU.
4. Changes or modifications to the H2RU equipment not expressly approved by the manufacturer could void the product warranty and the user’s authority to operate the equipment.
5. The shells of the device have protective ground terminals. During installation, connect the ground terminals securely to the protective building ground with yellow and green conductors or with braided ground wire. The aerial and feeder must be adequately grounded.
6. The power source must be within the required range of the device. The rated voltage range for the AC power supply system is 100 ~ 240 VAC, and the rated frequency range is 50 Hz / 60 Hz. The rated power of the AU, EU, and H2RU is 80 W, 50 W, and 250 W, respectively. The ground terminal of the three-core power socket used at the device installation site must be securely connected to the protective building ground.
7. To avoid injuries or damage, use care, and obtain assistance before lifting any heavy system components or equipment.
8. While fiber optic power levels used in this system are very low, it is advisable to avoid exposing the human eye to the laser light emanating from a fiber port or plug.
9. Signals coupled from the BTS shall be no greater than +15 dBm, otherwise, the device will not operate normally, and damage may occur to the circuit.
10. Reserve at least 40 mm of height above the radiation fins during device installation; otherwise, the device temperature may rise and affect the service life of the device.
11. Follow Electro Static Discharge precautions to avoid any damage to PCB, PSU, etc.
12. Keep equipment powered-off during installing or modifying.
13. Low path loss cables connected to antennas are highly recommended.
14. This is NOT a CONSUMER device. It is designed for installation by FCC LICENSEES and QUALIFIED INSTALLERS. You MUST have an FCC LICENSE or express consent of an FCC License to operate this device. Unauthorized use may result in significant forfeiture penalties, including penalties in excess of \$100,000 for each continuing violation.
15. This is NOT a CONSUMER device. It is designed for installation by an installer approved by an ISED licensee. You MUST have an ISED LICENCE or the express consent of an ISED licensee to operate this device.
16. To comply with FCC RF exposure compliance requirements, each individual antenna used for this transmitter must be installed to provide a separation distance greater than 225 cm or more from all persons during normal operation and must not be co-located with any other antenna for meeting RF exposure requirements.
17. In accordance with wireless service provider standards it is not advised to use digital repeaters as a signal source for Corning solutions.

Note: This device complies with Part 15 of the FCC Rules. Operation is subject to the following two conditions: (1) this device may not cause harmful interference, and (2) this device must accept any interference received, including interference that may cause undesired operation.

NOTE: This equipment has been tested and found to comply with the limits for a Class B digital device, pursuant to Part 15 of the FCC Rules. These limits are designed to provide reasonable protection against harmful interference in a residential installation. This equipment generates uses and can radiate radio frequency energy and, if not installed and used in accordance with the instructions, may cause harmful interference to radio communications. However, there is no guarantee that interference will not occur in a particular installation.

If this equipment does cause harmful interference to radio or television reception, which can be determined by turning the equipment off and on, the user is encouraged to try to correct the interference by one or more of the following measures:

- Reorient or relocate the receiving antenna.
- Increase the separation between the equipment and receiver.
- Connect the equipment into an outlet on a circuit different from that to which the receiver is connected.
- Consult the dealer or an experienced radio/TV technician for help.

Note: Only authorized person can enter the area where the antenna is installed. And the person is fully aware of the potential for exposure and can exercise control over his or her exposure by leaving the area or by some other appropriate means. Awareness of the potential for RF exposure in a workplace or similar environment can be provided through specific training as part of a RF safety program

Note: This device complies with Industry Canada license-exempt RSS standard(s). Operation is subject to the following two conditions: (1) this device may not cause interference, and (2) this device must accept any interference, including interference that may cause undesired operation of the device.

Le présent appareil est conforme aux CNR d'Industrie Canada applicables aux appareils radio exempts de licence. L'exploitation est autorisée aux deux conditions suivantes : (1) l'appareil ne doit pas produire de brouillage, et (2) l'utilisateur de l'appareil doit accepter tout brouillage radioélectrique subi, même si le brouillage est susceptible d'en compromettre le fonctionnement.

Site Considerations

1. The Everon™ 6200 complies with FCC RF exposure limits for an uncontrolled environment. This equipment must be installed and operated with a minimum distance of 400 cm for H2RU between the antennas and a person's body.
2. The system delay should be taken into consideration when there are neighboring BTS sites that are overlapping in coverage. Normal use of the system will not damage the base station; however, with the increase of RU during network coverage for indoor distribution, the uplink output noise level may affect the sensitivity of the base station, which should be considered during engineering design. Pick an ideal easy-to-reach location for installation convenience.
3. Pick an ideal easy-to-reach location for installation convenience.
4. Verify that there is a minimum of a 50 cm radius of space around the Everon™ 6200 equipment for the convenience of maintenance and on-site inspection.
5. Install the Everon™ 6200 close to the service area for monitor and debugging.

Environmental Considerations

Humidity and temperature can adversely affect reliability of the Everon™ 6200 system. Therefore, it is highly recommended to install the equipment in locations with stable humidity, temperature, and ventilation.

The equipment has to operate at humidity level and temperature range as follow:

- ✧ Maximum humidity: 85%
- ✧ Operating Temperature range: -10°C to +50°C
- ✧ Storage Temperature range: -25°C to +70°C

DC Power Connections

Referring to the diagram, connect the power cables as follows:

Higher voltage wire linked to **RED** cable / Lower voltage wire linked to **BLUE** cable.

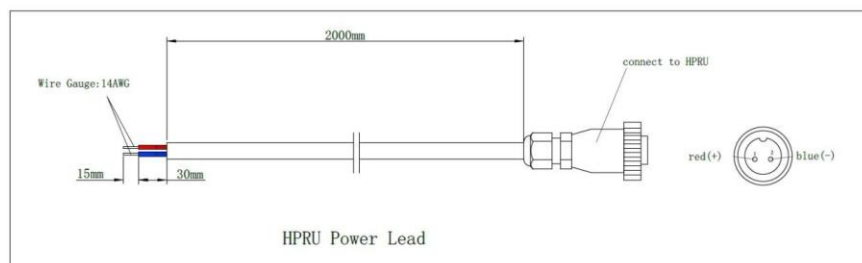
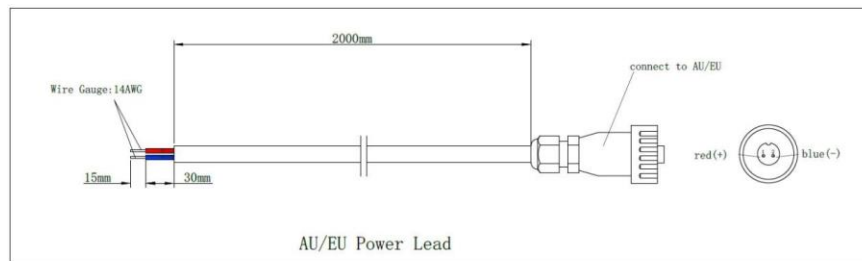

- ✧ Connect “+” to a high potential (+48 VDC from a +48 VDC power supply; 0 VDC from a -48 VDC power supply)
- ✧ Connect “-” to a low potential (0 VDC from a +48 VDC power supply; -48 VDC from a -48 VDC power supply)

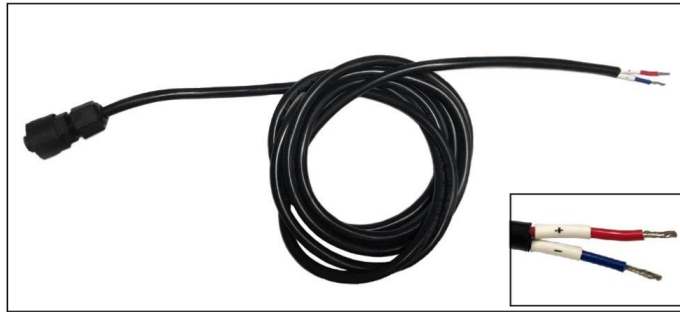

Cable Core	Cable Length	Maximum Expandable Length
14 AWG	2 m	10 m

Warning Marks

The warning marks should be kept clean, readable, and identifiable.



ALWAYS disconnect all lines and power connections before servicing or disassembling this equipment.



NEVER touch the surface after the device's power is turned on.



For performance and safety reasons, **NEVER** disassemble and remodel the devices.

Installation Preparation

Unpacking and Inspecting

This section discusses the procedures for receiving the shipment, inspecting the packing container, unpacking, and inspecting the device.

Inspecting the Packing Container

Handle the packing container carefully. Inspect the packing container immediately on arrival at the installation site to verify that no obvious damage occurred during shipment. Ensure that the container is sound and that the waterproof and vibration warning notices are still obvious. If possible, always inspect the equipment in the presence of the delivery person.

If any damage is observed:

1. Do not open or unpack the container.
2. Immediately contact the transportation carrier and notify them of the damage.
3. File a claim with the carrier once you determine the extent of any damage.
4. Return it to CORNING's nearest RMA facility and contact CORNING for RMA processing. '

Unpacking the Device

If the container appears to be in satisfactory condition:

1. Ensure both user and supplier representatives are in attendance during shipment inspection.
2. Confirm where you will store the device.
3. Ensure procedures are in place to handle the device and other equipment properly.
4. Ensure the following tools are available to unpack the shipment: hammer, paper cutter, and crowbar.
5. Open the packing container carefully. The device is contained in a protective package inside the packing container; however, caution is still necessary so as not to damage the internal package and device.
6. Remove the internal package from the packing container.
7. Unpack the device from the internal package carefully.

Verifying the Contents

To verify the contents of the package:

1. Verify that the contents and quantities agree with the Delivery Packing List.
2. Check the device model against the Delivery Packing List.
3. Notify CORNING immediately if any discrepancies are discovered, to verify whether the complete and correct shipment has been received.

Inspecting the Device

After unpacking the device, place the device on solid ground and check the following to ensure the device has not been damaged:

1. Inspect the device's appearance, overall dimensions, and weight.
2. Check that the device has not been deformed or bent in any way.
3. Check that there are no warps, scratches, bubbles, or dirt marks.
4. Check that there are no loose, missing or incorrectly fastened screws.
5. Check that the installation slots in the cabinet sub-rack are rectangular.
6. Ensure that the guide bar has not been damaged and the fittings and auxiliary parts are intact.
7. Check that the silk-screened images on the device are visible and intact.

Installation Preparation

Site Investigation

Before installation, the installer should contact the project director to ensure that the site is suitable for installation. Details required include information about the installation site, such as whether there is an iron tower or high mast nearby, the surrounding environmental conditions such as temperature and humidity, the power source, and so on. Installation staff should complete a site investigation with the project director before construction and conduct field observation of the installation site and the coverage area of the device, to confirm factors such as signal intensity, signal quality, the required coverage range, device location, antenna-feeder system, and power supply system.

Note: Only maintenance personnel or users who understand the reason for access, are experienced with restricted area access, and understand the necessary preventive measures should access the installation site.

Installation Tools

The following equipment and tools are required for a successful installation:

Electric percussion drill / Screwdriver / Wrench

Torque Settings

Type	M3	M6	M10
Specified Torques	0.6 nm	5 nm	50 nm

Clearance

You must ensure the following mounting clearances for mounting within a 19-inch rack/cabinet:

✧ Convection cooling:

Maintain 3U clearance between the bottom of the device and any other.

Maintain 3U clearance from the top surface of the device to the top of the rack.

✧ Fan Cooling:

You can mount the fan between the bottom of the device and any other.

Maintain 2U clearance between the bottom of the device and any other.

You must ensure the following mounting clearance:

✧ Convection cooling:

Maintain 150 mm clearance from the bottom of the device to any other planar obstructions.







Maintain 150 mm clearance from the top of the device to any other planar obstructions.

Maintain 150 mm clearance from both sides of the device to any other planar obstructions.

3. Installing the Access Unit (AU)



Accessories List

<p>① Screw M6*16</p> 	<p>② Screw M3*6</p> 
<p>③ Suspension Loop</p> 	<p>④ AC Power Lead 2.5m</p> 
<p>⑤ CAT-5 Cable 1.5m</p> 	<p>⑥ Ground Wire 2m</p> 

Rack Installation

The Access Unit (AU) is a 19-inch 1U equipment shelf. When installing the AU in a rack, make sure the mechanical loading of the rack is even to avoid a hazardous condition. The rack should safely support the combined weight of all the equipment and be securely anchored. Installing the AU in a climate-controlled room with sufficient air circulation is recommended as the maximum ambient temperature is +50°C.

To install the Access Unit (AU) in the equipment rack.

1. Attach the 19-inch mounting brackets at the front of the AU, using 4 screws M3x6 per bracket and the Phillips screwdriver. Observe the orientation of the brackets.



2. Recommended attaching the sliding rails to rack. (Not included in delivery).



3. Place the AU in the rack and secure the AU using 2 screws M6x16 on both side and the Phillips screwdriver.

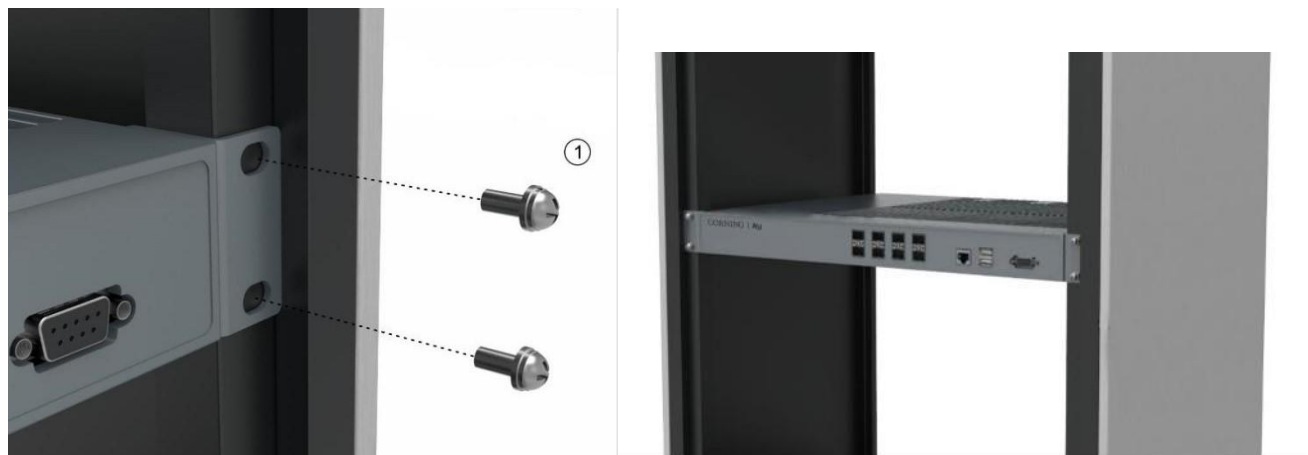

4. Install the fan for cooling if multiple AUs are installed in the same rack.

⚠ It is necessary to allow at least 3 rack units (132 mm) of free space below each unit for heat dissipation without fan installed or 1 rack unit (44 mm) of free space below each unit with fan occupied in the middle.

Otherwise, the device temperature may rise and affect the service life of the device.

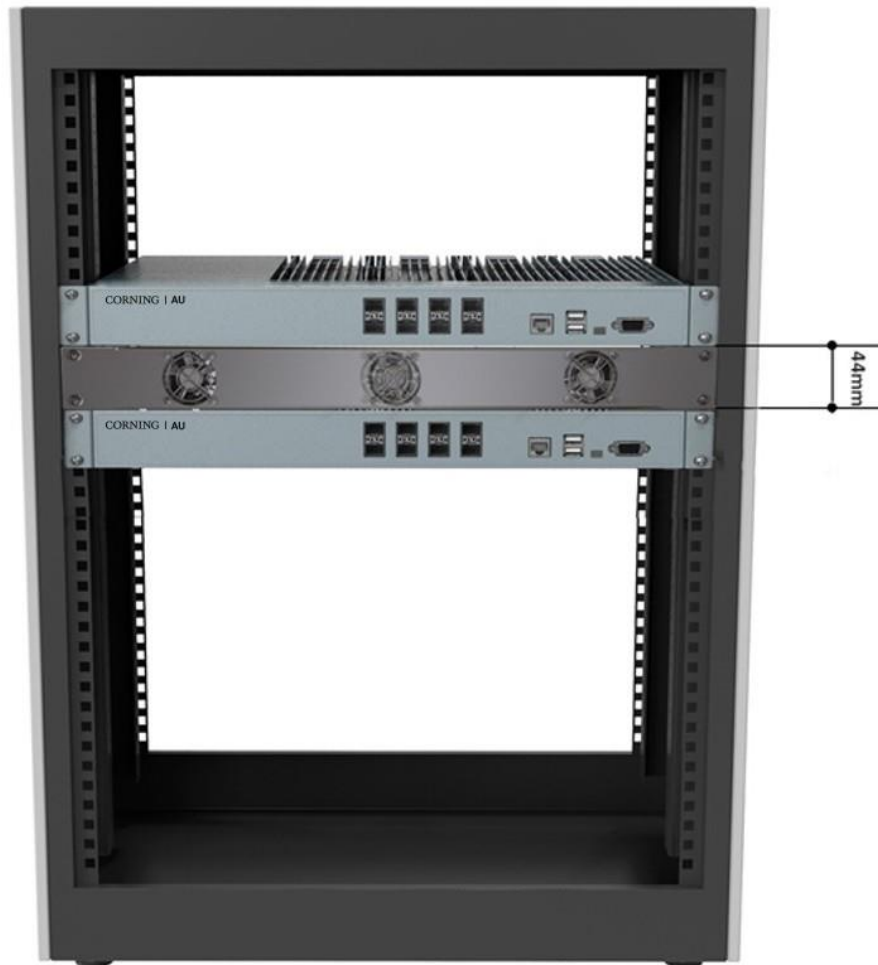

5. Connect and lock the power cable at the AU rear side.
6. Connect and screw the ground wire at the AU rear side.



Fan Installation

1. Secure the Fan using 2 screws M6x16 on both sides and the Phillips screwdriver

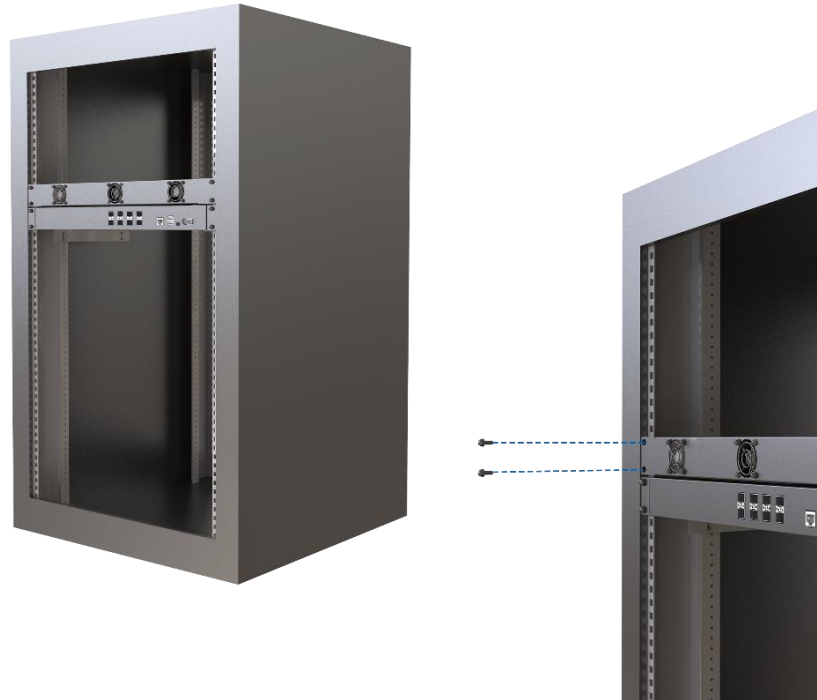

2. Plug AC power lead.



3. Fan DC version has power cable embedded in chassis.
Note: Red is for positive; Blue is for negative.

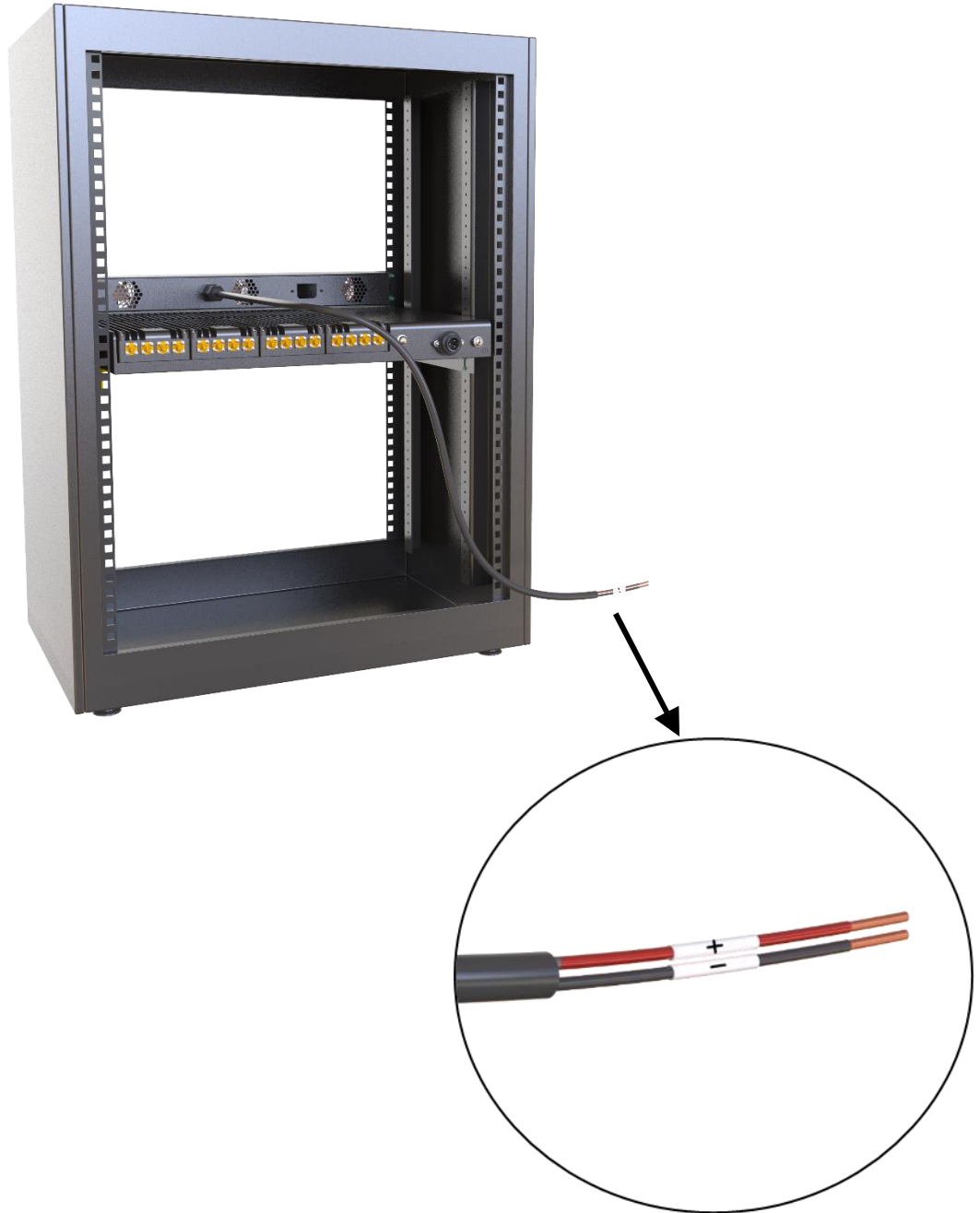

Wall Installation

To install the Access Unit (AU) on the wall:

1. Rotate the handles 90° and attach them at the rear of the AU, using 4 screws M3x6 per bracket and the Phillips screwdriver. Observe the orientation of the brackets.

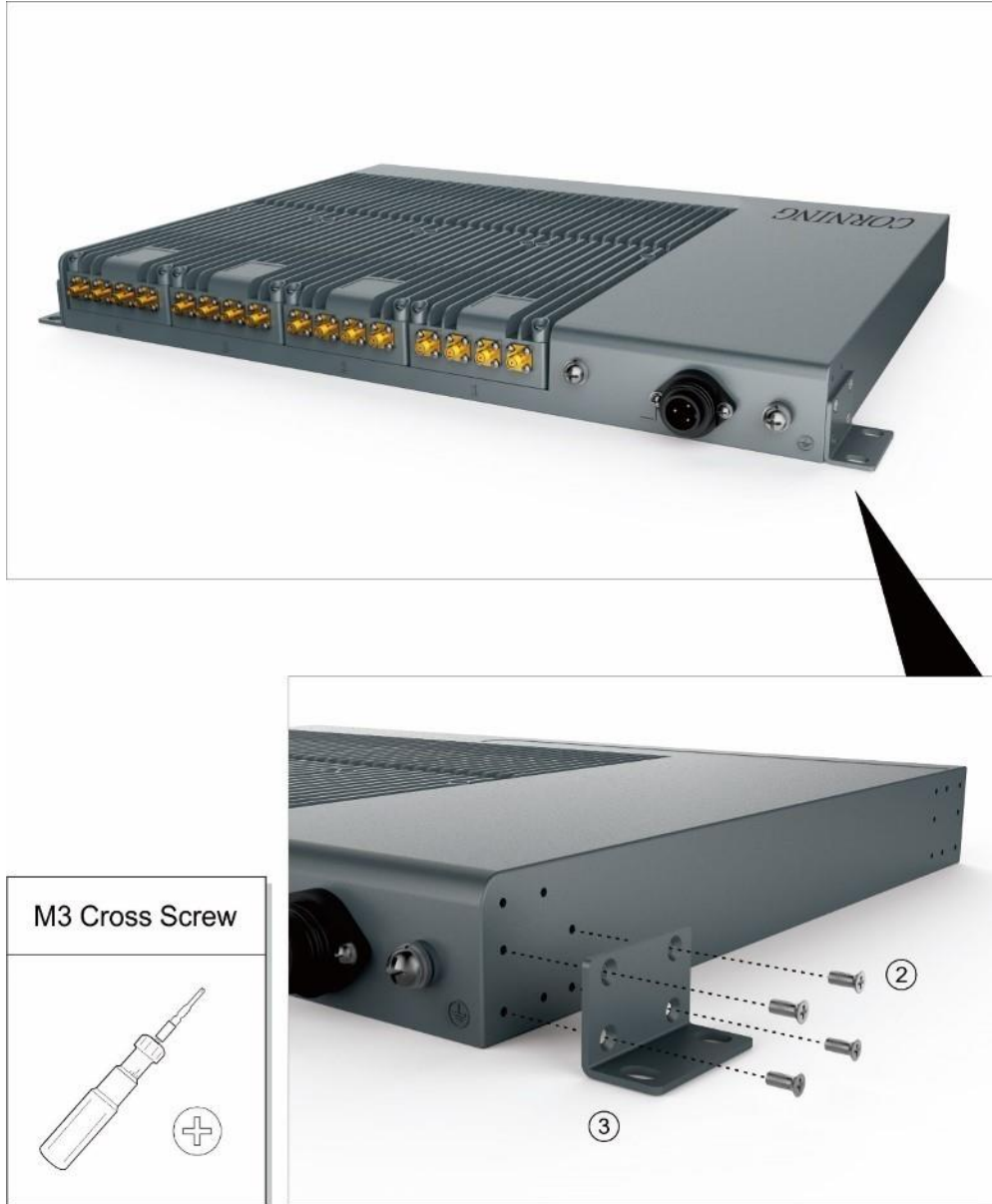

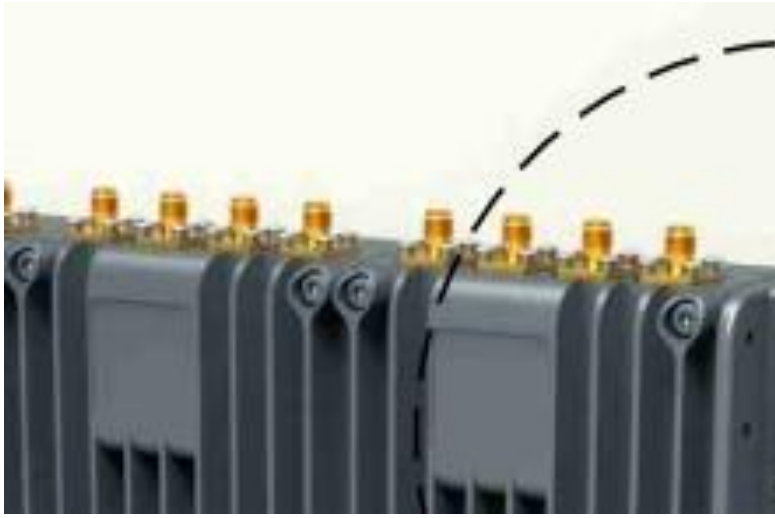

2. Mark 4 x $\varnothing 6.8\text{mm}$ drilling holes sites for the hanger to be attached to the wall.

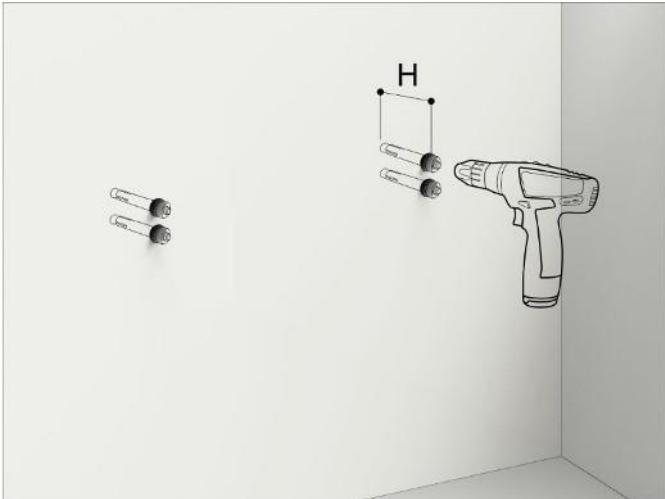

3. Drill 4 holes at the marked sites using percussion drill and embed 4x $\varnothing 10$ plastic expansion pipes. Note: H = 70mm. Fasten the case with 4xM6 expansion bolt.



Pen	Drill	Expansion Bolt
		

4. Connect and lock the power cable at the AU rear side.
5. Connect and screw the ground wire at the AU rear side.



AU Mounting Dimension Spacing

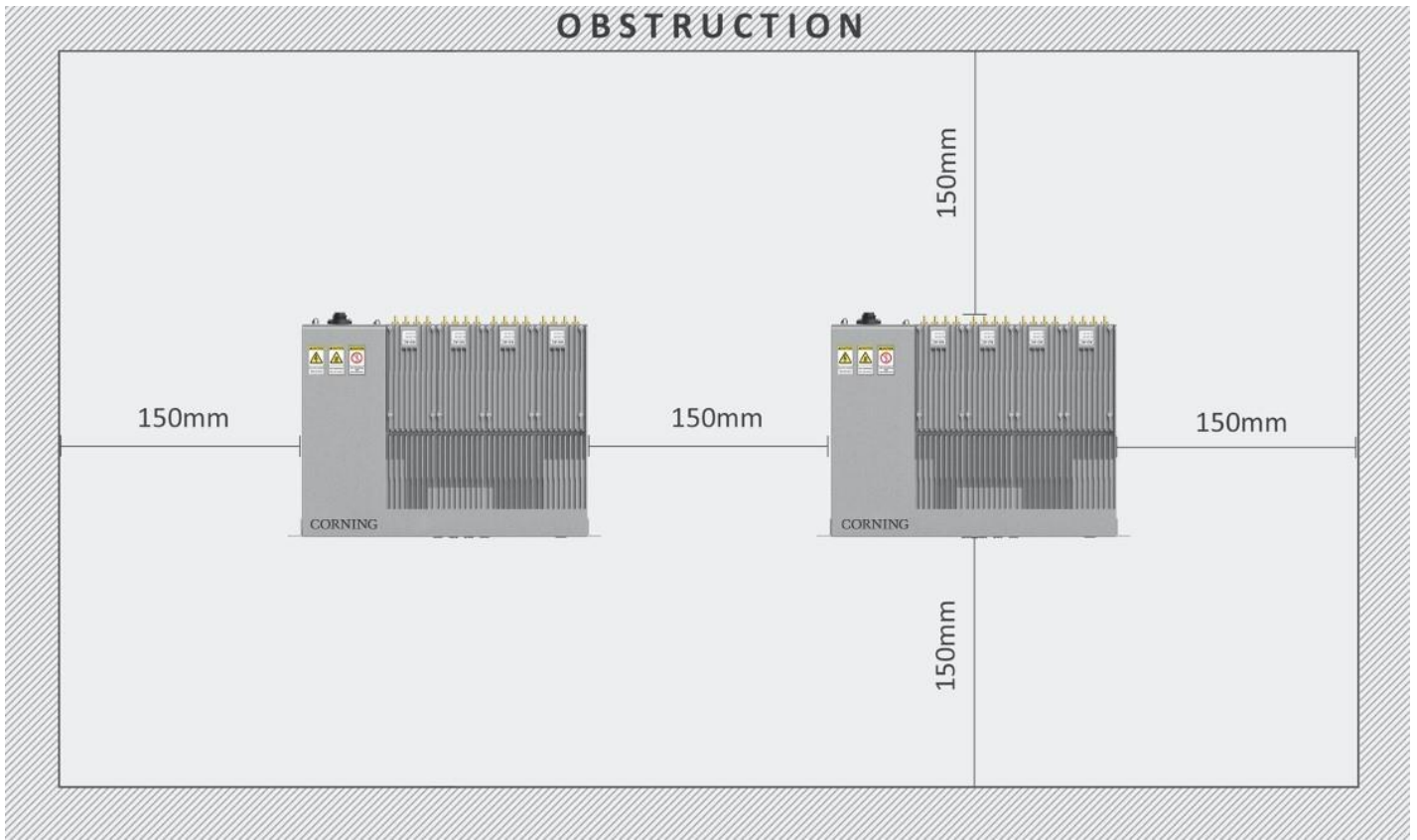

RF Connection

The RF interface between the Access Unit (AU) and the service provider signal source (or Everon 6200CPOI) is provided by duplex connections on the Active Combiner module. To route and connect the coaxial cables to the AU:

1. Obtain the required lengths of high performance, flexible, low-loss 50Ω coaxial cable for all coaxial connections and route the cables from the signal source or CPOI to the Active Combiner module.
2. Connect the cables from the signal source to the QMA female connectors on the Active Combiner module on the back panel of AU.

Note: Each Active Combiner module has four connectors to support up to four inputs.









AU Rear Panel Interfaces

SN	Interface Name	Description
1	Module 4 Duplexer Interface	QMA Female
2	Module 3 Duplexer Interface	QMA Female
3	Module 2 Duplexer Interface	QMA Female
4	Module 1 Duplexer Interface	QMA Female
5	Electric Power Line Interface	/
6	Grounding	/

4. Installing the Expansion Unit (EU-O)



Accessories List

	① Screw M6×16	② Screw M3×6
		
③ Suspension Loop	④ AC Power Lead 2.5m	
		
⑤ Optical Transceiver	⑥ Ground Wire 2m	
		

Rack Installation

The Expansion Unit is a 19-inch 1U equipment shelf. When installing the Access Unit in a rack, make sure the mechanical loading of the rack is even to avoid a hazardous condition. The rack should safely support the combined weight of all the equipment and be securely anchored. Installing the Expansion Unit in a climate-controlled room with sufficient air circulation is recommended as the maximum ambient temperature is +50°C.

To install the Expansion Unit in the equipment rack.

1. Attach the 19-inch mounting brackets at the front of the EU, using 4 screws M3x6 per bracket and the Phillips screwdriver. Observe the orientation of the brackets.

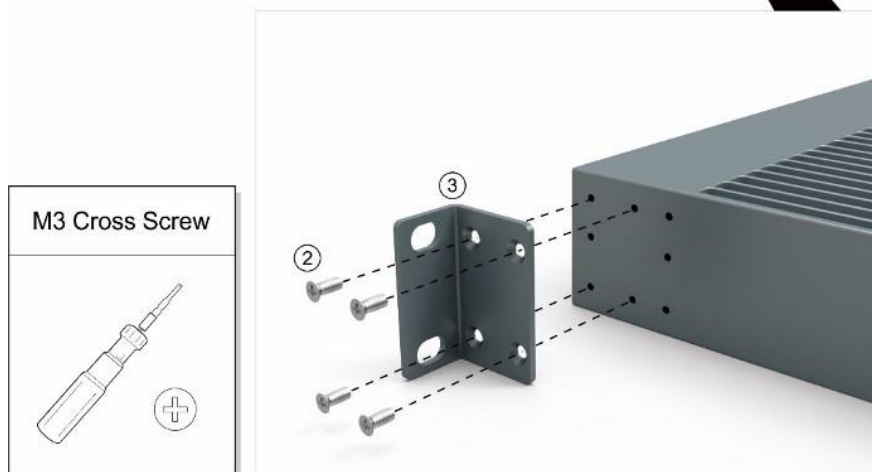

2. Recommended attachment of the sliding rails to rack. (Not included in delivery).

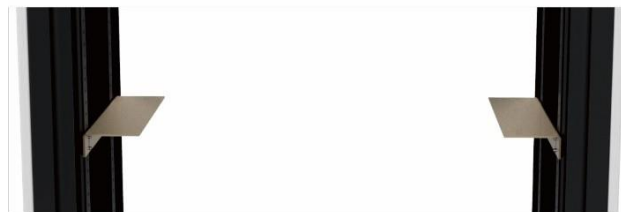

3. Place the EU in the rack and secure the EU using 2 screws M6x16 on both sides and the Phillips screwdriver.



4. Reserve enough free space or Install the fan for cooling if multiple devices are installed in the same rack.

⚠ It is necessary to allow at least 2 rack units (88 mm) of free space below each unit for heat dissipation without fan installed or 1 rack unit (44 mm) of free space below each unit with fan occupied in the middle. Otherwise, the device temperature may rise and affect the service life of the device.



5. Connect and lock the power cable at the EU rear side.
6. Connect and screw the ground wire at the EU rear side.



Wall Installation

To install the Expansion Unit (EU) on the wall:

1. Rotate the handles 90° and attach them at the rear of the EU, using 4 M3x6 screws per bracket and the Phillips screwdriver. Observe the orientation of the brackets.





2. Mark 4 x $\varnothing 6.8$ mm drilling holes sites for the hanger to be attached to the wall.



3. Drill 4 holes at the marked sites using percussion drill and embed 4x $\varnothing 10$ plastic expansion pipes. Note: H = 70mm. Fasten the case with 4xM6 expansion bolt.



Pen	Drill	Expansion Bolt
		

4. Connect and lock the power cable at the AU rear side.
5. Connect and screw the ground wire at the AU rear side.



EU-O Mounting Dimension Spacing

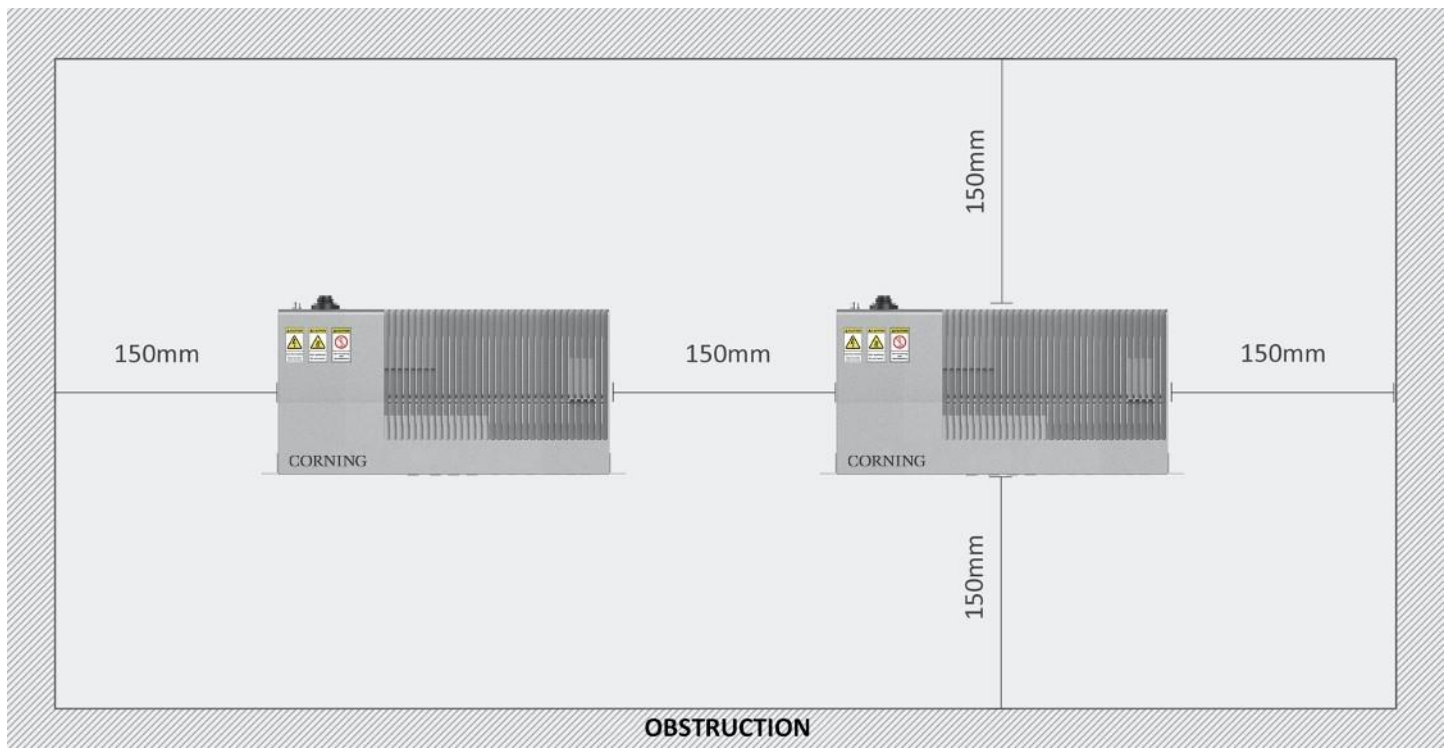

5. Installing the High-Power Remote Unit (H2RU)



Accessories List

HPRU Accessories List			
① Nut M10	② Screw M6×14	③ Flat Washer M10	④ Spring Washer M10
			
⑤ Handle		⑥ Expansion Bolt M10×90	
			
⑦ Optical Transceiver FTLX2071D327 Optical Transceiver FTLX2071D333	⑧ HPRU Mounting Bracket I	⑨ HPRU Mounting Bracket II	
			
⑩ AC Power Lead 2.5m			
			
⑪ Ground Wire 2m			
			

Wall Installation (Back on the Wall)

1. Attach and fasten the handle to the side of H2RU with screws M6×14 using T5 Wrench.

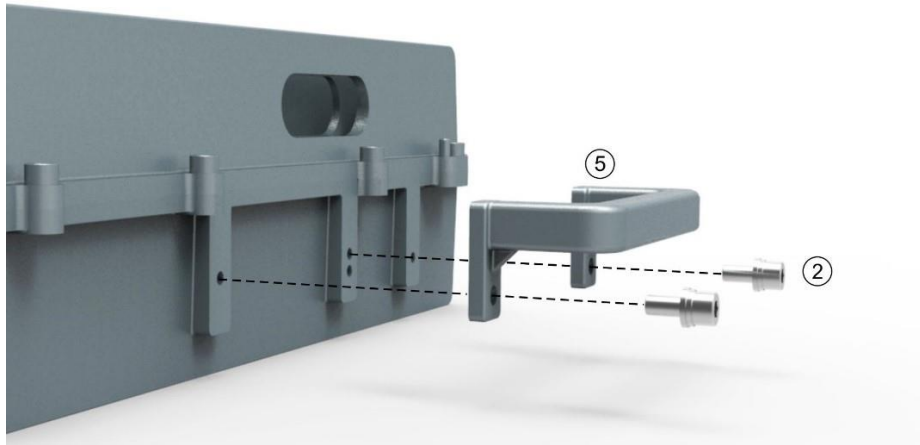

2. Attach and fasten the Bracket I to the back of H2RU with screws M6×14 using T5 Wrench.

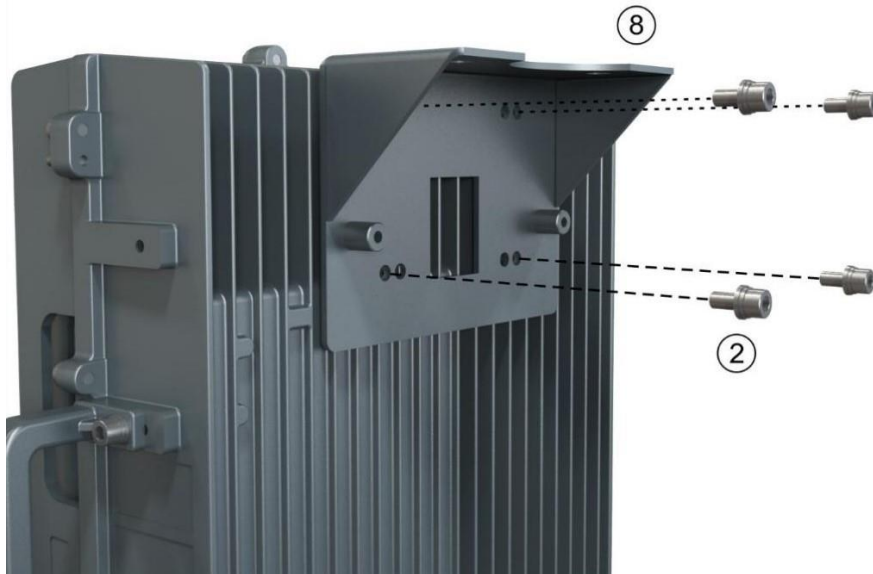

3. Mark the position of the drilling holes in the mounting Bracket II. Note: $R = 13 \text{ mm}$.

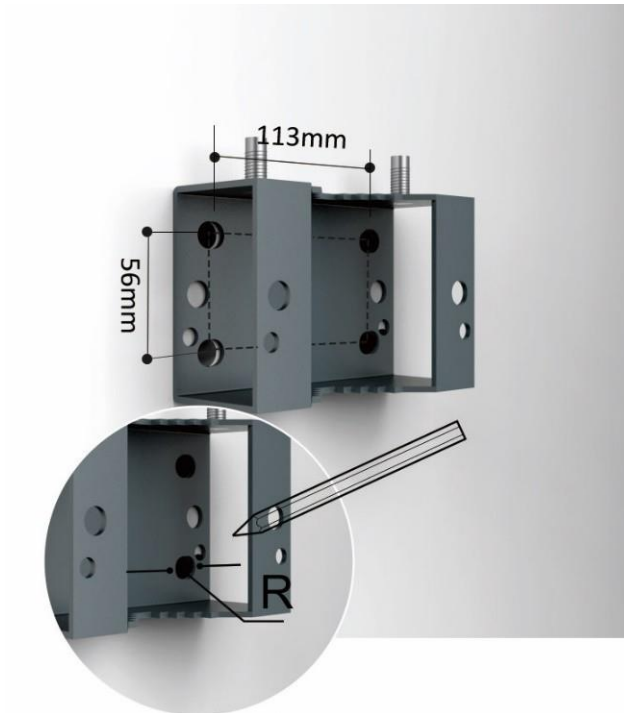

4. Drill 4 holes at the marked positions. Note: $H = 70 \text{ mm}$



5. Attach the dowels, expansion screws or the like and fasten the Bracket II to the wall.

Tips: Use Bracket II as a reference to control each devices' separation distance before hanging and locking H2RU up.

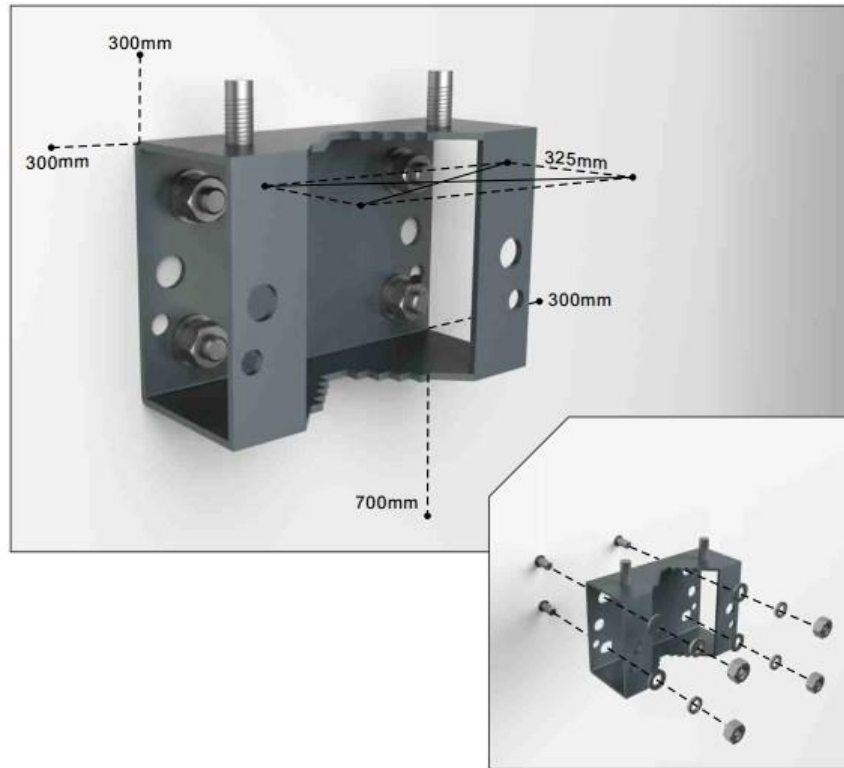

6. Hang the H2RU on the mounting Bracket II and fasten with nuts M10.

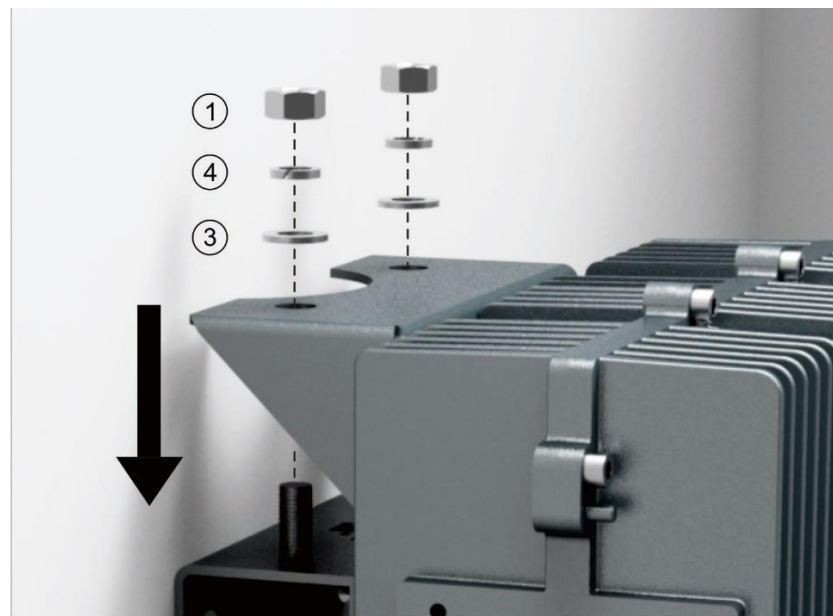

7. Fasten the Bracket I and II with screws M6x14.



8. Connect and lock the power cable at the H2RU rear side.



9. Connect and screw the ground cable at the H2RU's left side.

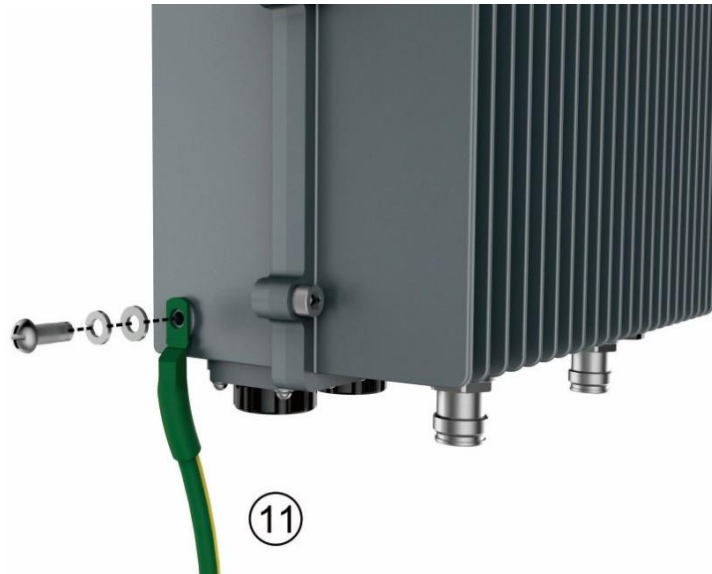

Wall Installation (Side on the Wall)

1. Attach and fasten the handle to the side of H2RU with screws M6×14 using T5 Wrench.

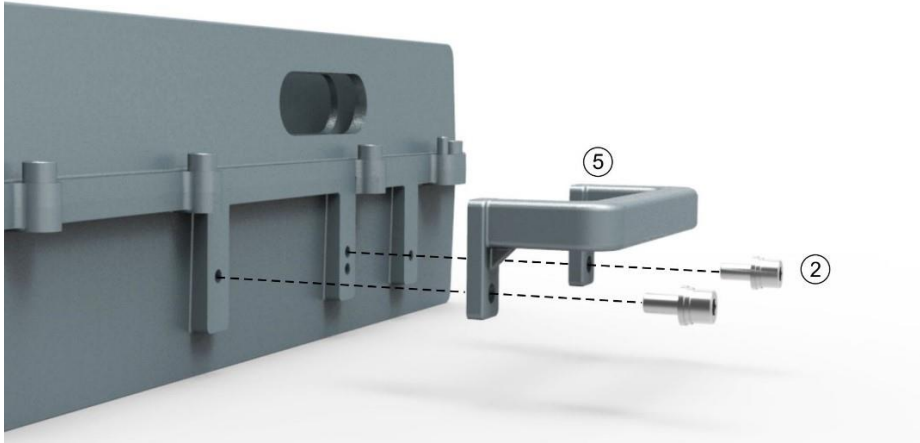

2. Attach and fasten the Bracket I to the left side of H2RU with screws M6×14 using T5 Wrench.

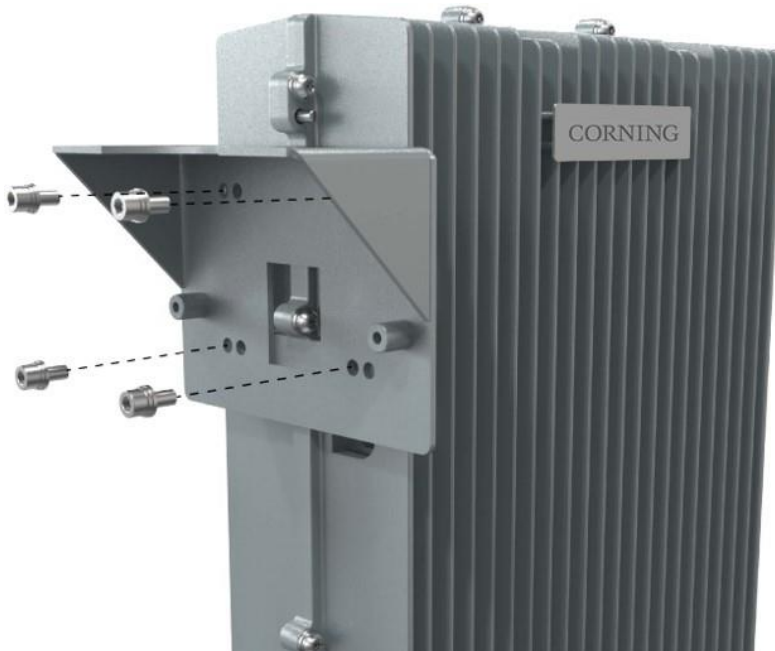

3. Mark the position of the drilling holes in the mounting Bracket II. Note: $R = 13\text{ mm}$.

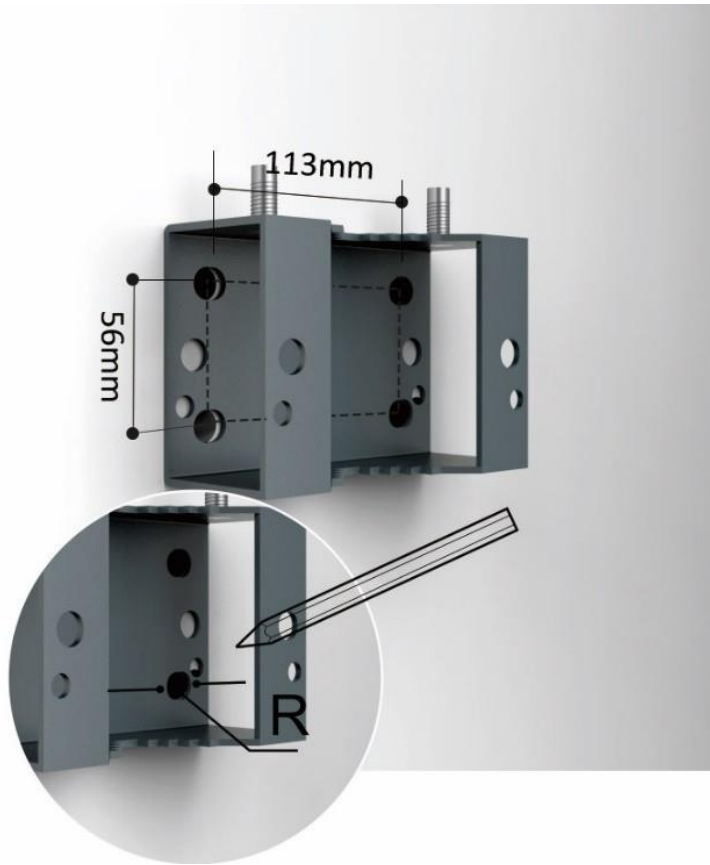

4. Drill 4 holes at the marked positions. Note: $H = 70\text{ mm}$.



5. Attach the dowels, expansion screws or the like and fasten the Bracket II to the wall.

Tips: Use Bracket II as a reference to control each devices' separation distance before hanging and locking H2RU up.

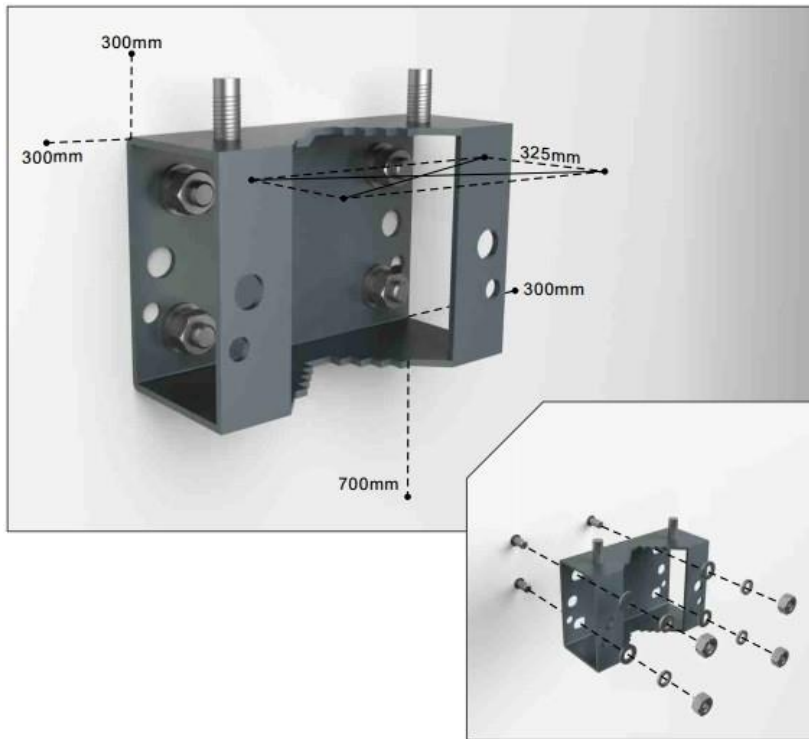

6. Hang the H2RU on the mounting Bracket II and fasten with nuts M10.



7. Fasten the Bracket I and II with screws M6x14.



8. Connect and lock the power cable at the H2RU rear side.



9. Connect and screw the ground cable at the H2RU left side.

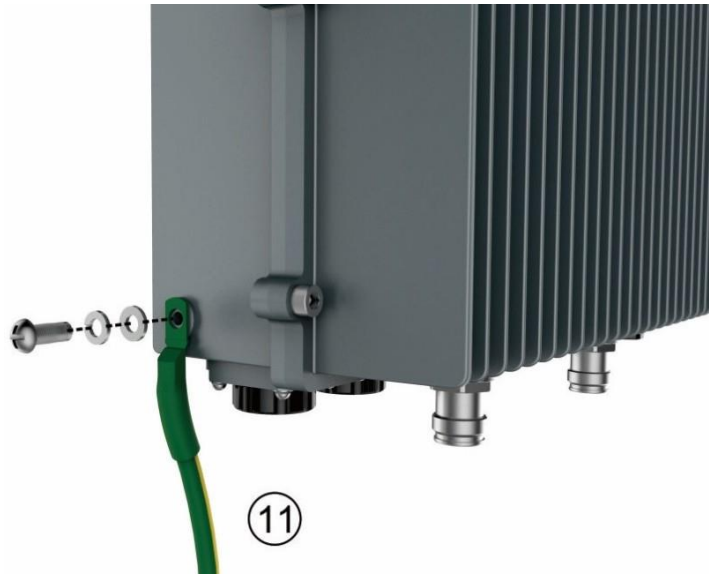

Pole Installation

1. Install the handle and Bracket I to the back of H2RU.
2. Install the Bracket II and Bracket III to the pole.
3. Hang the H2RU on the mounting bracket and fasten with nuts M10.
4. Connect the ground cable and power cable.

 Extra accessories are required for pole installation and purchased separately.

Note: The diameter of Pole shall not be over 110 mm or less than 55 mm.

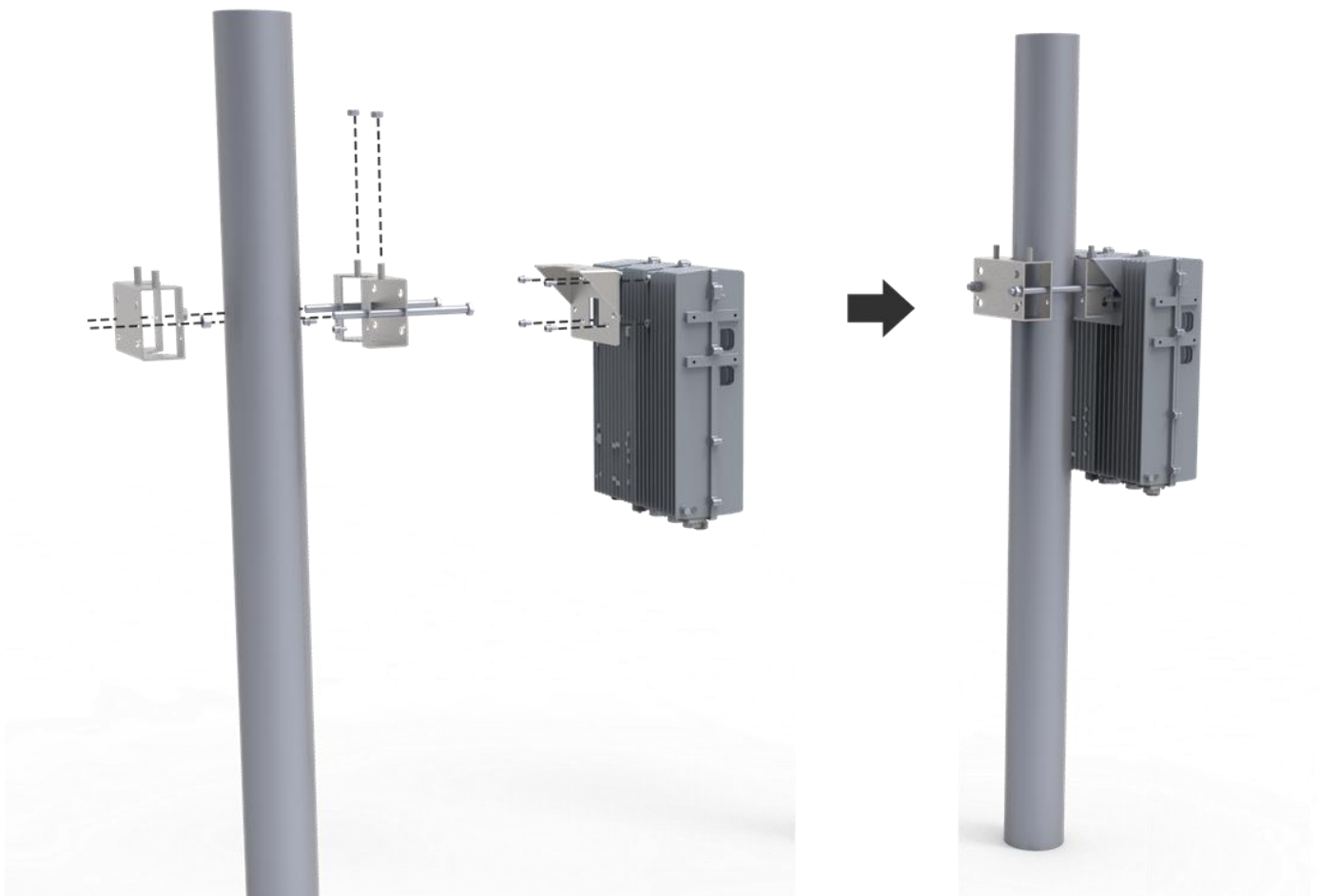

H2RU Mounting Dimension Spacing

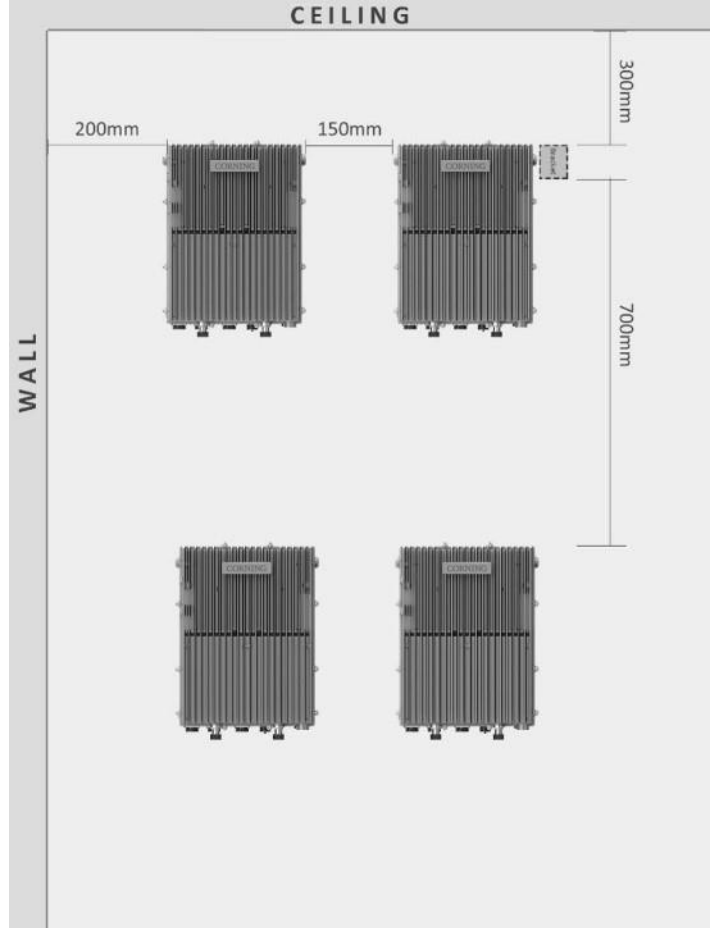
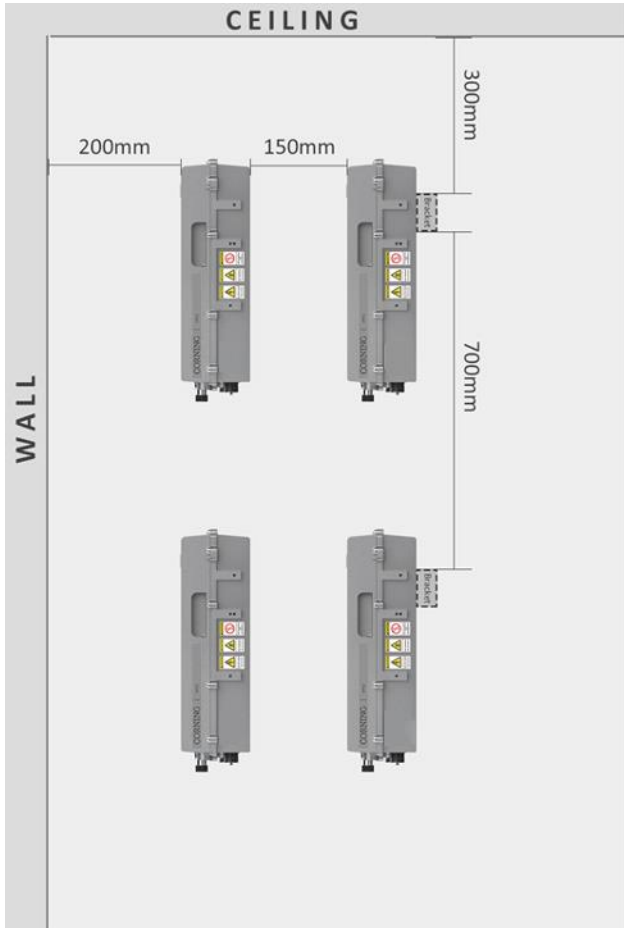

6. Optical Connection

Optical Transceiver Module

Single-Port Bidirectional SFP Transceiver

The Figure below shows a pair of single-port Bidirectional SFP transceivers. For devices optical connection, the transceivers of two sides must be paired -- the wavelength of one side is 1271 nm, and the wavelength of another side is 1331 nm. Otherwise, it will fail the connection. All lower-level devices under this port won't be working in the system.

All the optical ports of all type devices have triangle LED indicators pointing to each port, which represent the synchronization status of the upper and lower optical modules. The indicator turns to green when optical modules are plugged in ports and synchronized. When the connection is down, or there is no optical module in port, the indicator remains red.



 The single-port SFP modules have to be used in pairs.

Dual-Port SFP Transceiver

The optical connector unit includes an optical module and optical fiber. The Figure below shows that when using a dual-port SFP module, the optical transmitter and optical receiver should correspond to each other. In other words, the optical transmitter of optical module A should correspond to the optical receiver of optical module B, and the receiver of A should correspond to the transmitter of B. The optical receiver and transmitter terminals of the optical module can be determined by the triangular mark on the optical module. The triangular mark in the yellow box and the red and blue lines indicate the optical fiber connections.

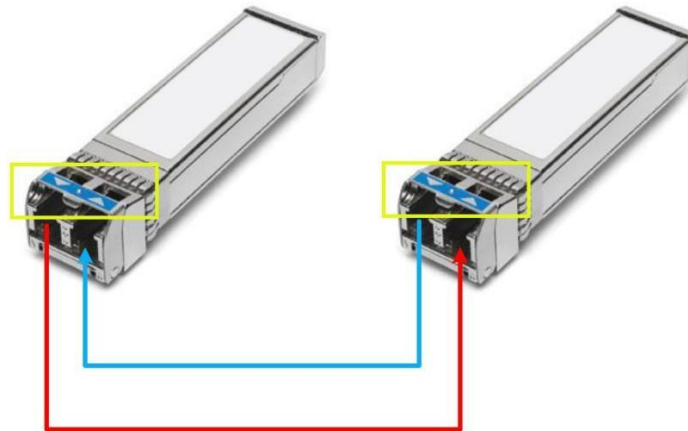

Optical Indicator

Each pair (2) of optical module cages has four LED indicator arrows. The two on the left are green, and the two on the right are red, as shown in Figure below. The indicator arrows represent the synchronization status of the upper and lower optical modules. When a pair of optical modules are synchronized (both uplink and downlink), the indicators turn green as shown in the right pair of indicators in Figure below. When the optical module is unplugged or not synchronized, the indicators are red, as shown in the left pair of indicators. Check whether both indicators turn green after connecting one pair of optical modules. If the indicators are red, the terminal has not synchronized.

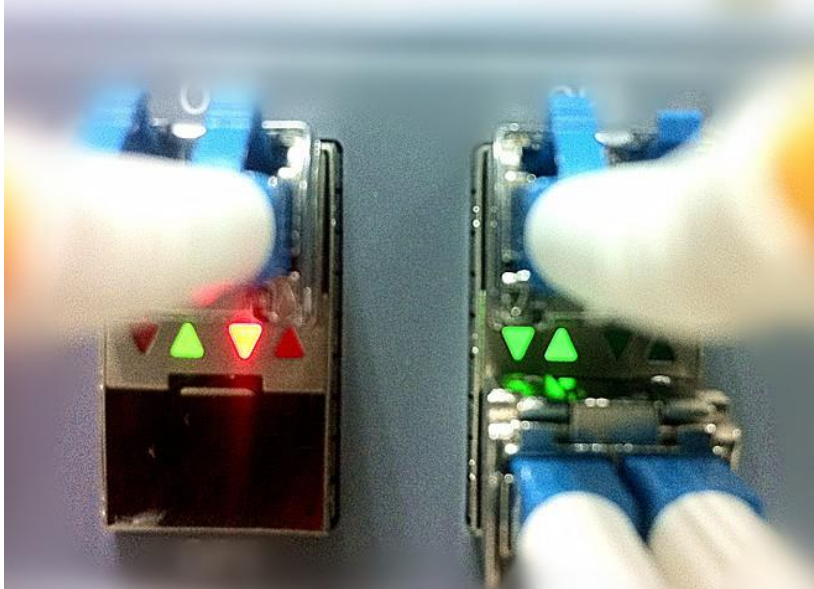

AU Optical Port Description

Obtain the required lengths of optical fibers for all the optical connections and connect the fibers on the front panel of the Access Unit (AU). The interface type of SFP transceivers is an LC connector. It is important to label all ports on the fiber distribution panel correctly. It is recommended to include additional length/slack in the optical fiber to allow future reconfigurations without requiring additional splices.

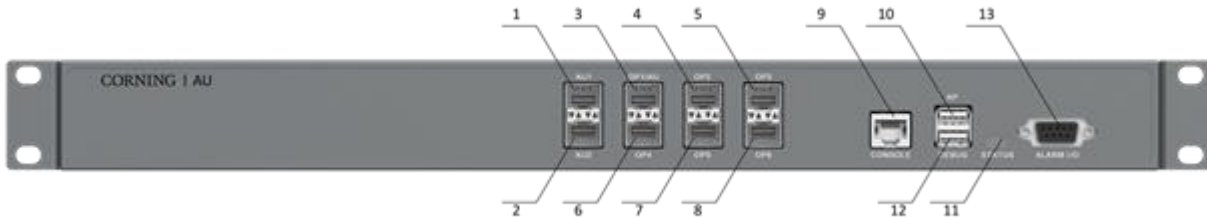

AU Front Panel Interfaces

SN	Interface Name	Description
1	AU1	Connects Slave AU1
2	AU2	Connects Slave AU2
3	OP1/AU	For Master AU: connects EU/RU For Slave AU: connects Master AU
4	OP2	Connects EU/RU
5	OP3	Connects EU/RU
6	OP4	Connects EU/RU
7	OP5	Connects EU/RU
8	OP6	Connects EU/RU
9	CONSOLE	Connects OMC or local PC through CAT-5 for local and remote monitoring
10	AP	Connects WLAN network adapters for monitoring device through Wi-Fi
11	STATUS	Indicates device operating status
12	DEBUG	Connects local debugging PC through a USB connection
13	ALARM I/O	Connects external environment alarm interface for environment monitoring

EU-O Optical Port Description

Obtain the required lengths of optical fibers for all the optical connections and connect the fibers on the front panel of the Expansion Unit (EU). The interface type of SFP transceivers is an LC connector. It is important to label all ports on the fiber distribution panel correctly. It is recommended to include additional length/slack in the optical fiber to allow future reconfigurations without requiring additional splices.

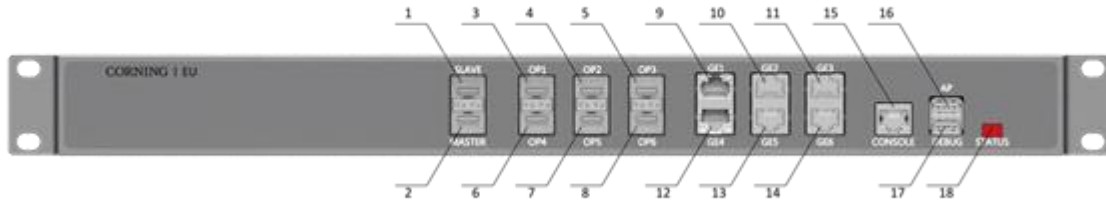

EU Front Panel Interfaces

SN	Interface Name	Description
1	SLAVE	Connection for Master AU/EU at the next higher level
2	MASTER	Connection for EU at the next lower level
3	OP1	Connection for RU
4	OP2	Connection for RU
5	OP3	Connection for RU
6	OP4	Connection for RU
7	OP5	Connection for RU
8	OP6	Connection for RU
9	GE1	Wi-Fi signals or S1 signals input
10	GE2	Wi-Fi signals or S1 signals input
11	GE3	Wi-Fi signals or S1 signals input
12	GE4	Wi-Fi signals or S1 signals input
13	GE5	Wi-Fi signals or S1 signals input
14	GE6	Wi-Fi signals or S1 signals input
15	CONSOLE	Connection for local PC through CAT-5 for local monitoring
16	AP	Connection for WLAN Network adapters for monitoring device through Wi-Fi
17	DEBUG	Connection for local debugging PC through USB wire
18	STATUS	Indicates device operating status

RU Optical Port Description

Obtain the required lengths of optical fibers for all the optical connections and connect the fibers on the front panel of Remote Unit (RU). The interface type of SFP transceivers is an LC connector. It is important to label all ports on the fiber distribution panel correctly. It is recommended to include additional length/slack in the optical fiber to allow future reconfigurations without requiring additional splices.

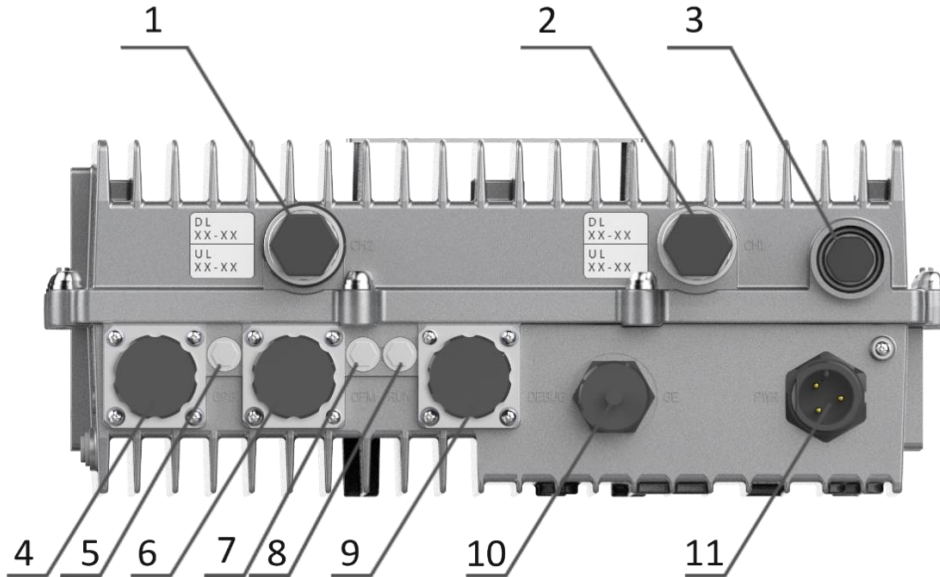

RU Front Panel Interfaces

SN	Interface Name	Description
1	CH2	PA 2 Module Interface, 4.3-10 female connector
2	CH1	PA 1 Module Interface, 4.3-10 female connector
3	Air Pressure hole	Make the pressure balance
4	Slave OP	Connection for EU or RU at the next higher level
5	Slave	Indicates Slave OP port operating status
6	MASTER OP	Connection for RU at the next lower level
7	Master	Indicates Master OP port operating status
8	RUN	Indicates device operating status
9	DEBUG	Connection for local PC through CAT-5 for local monitoring
10	GE	Wi-Fi signal output port
11	PWR	Electrical Power Line Interface

FCC Warning:

This device complies with Part 15 of the FCC Rules. Operation is subject to the following two conditions:

- (1) This device may not cause harmful interference, and
- (2) This device must accept any interference received, including interference that may cause undesired operation.

Part20 Warning :

Note: This product has been tested and found to comply with the limits for a Class B digital device, pursuant to Part 15 of the FCC Rules. These limits are designed to provide reasonable protection against harmful interference in a residential installation. This product generates, uses, and can radiate radio frequency energy and, if not installed and used in accordance with the instructions, may cause harmful interference to radio communications. However, there is no guarantee that interference will not occur in a particular installation. If this product does cause harmful interference to radio or television reception, which can be determined by turning the equipment off and on, the user is encouraged to try to correct the interference by one or more of the following measures:

- Reorient or relocate the receiving antenna.
- Increase the separation between the equipment and receiver.
- Connect the equipment into an outlet on a circuit different from that to which the receiver is connected.
- Consult the dealer or an experienced radio/TV technician for help.

The logo consists of a solid blue square on the left. To its right, the word "CORNING" is written in a white, serif, all-caps font.

**Corning Optical Communications LLC • 4200 Corning Place • Charlotte, NC 28216 USA 800-743-2675
FAX: 828-325-5060 • International: +1-828-901-5000 • www.corning.com/opcomm**

Corning Optical Communications reserves the right to improve, enhance, and modify the features and specifications of Corning Optical Communications products without prior notification. A complete listing of the trademarks of Corning Optical Communications is available at www.corning.com/opcomm/trademarks. All other trademarks are the properties of their respective owners. Corning Optical Communications is ISO 9001 certified. © 2021 Corning Optical Communications. All rights reserved. CMA-793-AEN /July 2021