

# TEST REPORT

**Application No.:** GZCR2208001013AT  
**Applicant:** Corning Optical Communication LLC  
**Address of Applicant:** 6 Concord Road, Shrewsbury, MA 01545 United States  
**Manufacturer:** Comba Network System Company Limited  
**Address of Manufacturer:** No.10 Shenzhou Road, Guangzhou Science City, Guangzhou, Guangdong  
**Factory:** Comba Telecom Technology (Guangzhou) Ltd.  
**Address of Factory:** No.6 Jinbi Road, Economics and Technology Development District, Guangdong, China

### Equipment Under Test (EUT):

**EUT Name:** Digital Low-power Remote Unit High Band Supporting 2.5G  
**Model No.:** dLRU-G2-25  
**Standard(s) :** 47 CFR Part 2  
47 CFR Part 20  
47 CFR Part 27

**Date of Receipt:** 2022-08-05  
**Date of Test:** 2022-08-08 to 2022-08-16  
**Date of Issue:** 2022-08-19

<b>Test Result:</b>	<b>Pass*</b>
---------------------	--------------



\* In the configuration tested, the EUT complied with the standards specified above.



Kobe Jian  
EMC Laboratory Manager



Revision Record			
Version	Chapter	Date	Remark
01	GZCR220800101302	2022-08-19	Original

<b>Authorized for issue by:</b>			
			
	<b>Kevin Zhang /Project Engineer</b>		
			
	<b>Jerry Chan /Reviewer</b>		



Unless otherwise agreed in writing, this document is issued by the Company subject to its General Conditions of Service printed overleaf, available on request or accessible at <http://www.sgs.com/en/Terms-and-Conditions.aspx> and, for electronic format documents, subject to Terms and Conditions for Electronic Documents at <http://www.sgs.com/en/Terms-and-Conditions/Terms-e-Documents.aspx>. Attention is drawn to the limitation of liability, indemnification and jurisdiction issues defined therein. Any holder of this document is advised that information contained hereon reflects the Company's findings at the time of its intervention only and within the limits of Client's instructions, if any. The Company's sole responsibility is to its Client and this document does not exonerate parties to a transaction from exercising all their rights and obligations under the transaction documents. This document cannot be reproduced except in full, without prior written approval of the Company. Any unauthorized alteration, forgery or falsification of the content or appearance of this document is unlawful and offenders may be prosecuted to the fullest extent of the law. Unless otherwise stated the results shown in this test report refer only to the sample(s) tested and such sample(s) are retained for 30 days only.

Attention: To check the authenticity of testing /inspection report & certificate, please contact us at telephone: (86-755) 8307 1443, or email: [CN.Doccheck@sgs.com](mailto:CN.Doccheck@sgs.com)

## 2 Test Summary

Item	Standard	Method	Requirement	Result
Out-of-band rejection	KDB935210 D05 v01r04	KDB935210 D05 v01r04 clause 3.3	KDB935210 D05 v01r04 clause 3.3	Pass
Input-versus-output signal comparison	47 CFR Part 2	KDB935210 D05 v01r04 clause 3.4	Part 2.1049	Pass
Mean output power and amplifier/booster gain	47 CFR Part 27	KDB935210 D05 v01r04 clause 3.5	Part 27.50(h)	Pass
Out-of-band/out-of-block(including intermodulation) emissions		KDB935210 D05 v01r04 clause 3.6	Part 27.53(m)	Pass
Conducted spurious emissions		KDB935210 D05 v01r04 clause 3.6	Part 27.53(m)	Pass
Frequency stability		47 CFR Part 2.1055 KDB935210 D05 v01r04 clause 3.7 ANSI C63.26-2015 Clause 5.6	Part 27.54	Pass
Radiated spurious emissions		KDB935210 D05 v01r04 clause 3.8 ANSI C63.26-2015 Clause 5.5	Part 27.53(m)	Pass

The EUT is a low-power remote antenna unit of fiber DAS. It receives base-station downlink via fiber-optic or coaxial cable from host unit, transmits via antenna to handset, and returns handset uplink via fiber-optic or coaxial cable to host unit. The host unit connects directly to a base station via coaxial cable but cannot connect to antenna.

**Therefore, no need to implement uplink test.**

**Note:**

E.U.T./ EUT means Equipment Under Test

Pass means the test result passed the test standard requirement, please find the detailed decision rule in the report relative section.



Unless otherwise agreed in writing, this document is issued by the Company subject to its General Conditions of Service printed overleaf, available on request or accessible at <http://www.sgs.com/en/Terms-and-Conditions.aspx> and, for electronic format documents, subject to Terms and Conditions for Electronic Documents at <http://www.sgs.com/en/Terms-and-Conditions/Terms-e-Documents.aspx>. Attention is drawn to the limitation of liability, indemnification and jurisdiction issues defined therein. Any holder of this document is advised that information contained hereon reflects the Company's findings at the time of its intervention only and within the limits of Client's instructions, if any. The Company's sole responsibility is to its Client and this document does not exonerate parties to a transaction from exercising all their rights and obligations under the transaction documents. This document cannot be reproduced except in full, without prior written approval of the Company. Any unauthorized alteration, forgery or falsification of the content or appearance of this document is unlawful and offenders may be prosecuted to the fullest extent of the law. Unless otherwise stated the results shown in this test report refer only to the sample(s) tested and such sample(s) are retained for 30 days only.  
**Attention: To check the authenticity of testing /inspection report & certificate, please contact us at telephone: (86-755) 8307 1443, or email: CN.Doccheck@sgs.com**

### 3 Contents

	Page
1 Covers Page .....	1
2 Test Summary .....	3
3 Contents .....	4
4 General Information.....	6
4.1 Details of EUT.....	6
4.2 Description of Support Units.....	7
4.3 Test Environment.....	7
4.4 Test Signals and Channel .....	8
4.5 Measurement Uncertainty .....	8
4.6 Test Location.....	8
4.7 Test Facility.....	9
4.8 Deviation from Standards .....	9
4.9 Abnormalities from Standard Conditions .....	9
5 Equipment List.....	10
6 Radio Spectrum Matter Test Results.....	12
6.1 Out-of-band rejection .....	12
6.1.1 E.U.T. Operation .....	12
6.1.2 Test Setup.....	12
6.1.3 Test Procedure.....	13
6.1.4 Measurement Record.....	13
6.2 Input versus output comparison .....	14
6.2.1 E.U.T. Operation .....	14
6.2.2 Test Setup.....	14
6.2.3 Test Procedure.....	15
6.2.4 Measurement Record.....	15
6.3 Mean output power and amplifier/booster gain .....	16
6.3.1 E.U.T. Operation .....	16
6.3.2 Test Setup.....	16
6.3.3 Test Procedure.....	17
6.3.4 Measurement Record.....	17
6.4 Out-of-band/out-of-block(including intermodulation) emissions .....	18
6.4.1 E.U.T. Operation .....	18
6.4.2 Test Setup.....	18
6.4.3 Test Procedure.....	19
6.4.4 Measurement Record.....	19
6.5 Conducted Spurious emissions .....	20
6.5.1 E.U.T. Operation .....	20
6.5.2 Test Setup.....	20
6.5.3 Test Procedure.....	21
6.5.4 Measurement Record.....	21



Unless otherwise agreed in writing, this document is issued by the Company subject to its General Conditions of Service printed overleaf, available on request or accessible at <http://www.sgs.com/en/Terms-and-Conditions.aspx> and, for electronic format documents, subject to Terms and Conditions for Electronic Documents at <http://www.sgs.com/en/Terms-and-Conditions/Terms-e-Documents.aspx>. Attention is drawn to the limitation of liability, indemnification and jurisdiction issues defined therein. Any holder of this document is advised that information contained hereon reflects the Company's findings at the time of its intervention only and within the limits of Client's instructions, if any. The Company's sole responsibility is to its Client and this document does not exonerate parties to a transaction from exercising all their rights and obligations under the transaction documents. This document cannot be reproduced except in full, without prior written approval of the Company. Any unauthorized alteration, forgery or falsification of the content or appearance of this document is unlawful and offenders may be prosecuted to the fullest extent of the law. Unless otherwise stated the results shown in this test report refer only to the sample(s) tested and such sample(s) are retained for 30 days only.

Attention: To check the authenticity of testing /inspection report & certificate, please contact us at telephone: (86-755) 8307 1443, or email: [CN.Doccheck@sgs.com](mailto:CN.Doccheck@sgs.com)

<b>6.6</b>	<b>Frequency Stability</b> .....	<b>22</b>
6.6.1	E.U.T. Operation .....	22
6.6.2	Test Setup .....	22
6.6.3	Test Procedure .....	23
6.6.4	Measurement Record .....	23
<b>6.7</b>	<b>Radiated Spurious emission</b> .....	<b>24</b>
6.7.1	E.U.T. Operation .....	24
6.7.2	Test Setup .....	24
6.7.3	Test procedure .....	26
6.7.4	Measurement Record .....	26
<b>7</b>	<b>Test Setup Photographs</b> .....	<b>27</b>
<b>8</b>	<b>EUT Constructional Details (EUT Photos)</b> .....	<b>27</b>



Unless otherwise agreed in writing, this document is issued by the Company subject to its General Conditions of Service printed overleaf, available on request or accessible at <http://www.sgs.com/en/Terms-and-Conditions.aspx> and, for electronic format documents, subject to Terms and Conditions for Electronic Documents at <http://www.sgs.com/en/Terms-and-Conditions/Terms-e-Documents.aspx>. Attention is drawn to the limitation of liability, indemnification and jurisdiction issues defined therein. Any holder of this document is advised that information contained hereon reflects the Company's findings at the time of its intervention only and within the limits of Client's instructions, if any. The Company's sole responsibility is to its Client and this document does not exonerate parties to a transaction from exercising all their rights and obligations under the transaction documents. This document cannot be reproduced except in full, without prior written approval of the Company. Any unauthorized alteration, forgery or falsification of the content or appearance of this document is unlawful and offenders may be prosecuted to the fullest extent of the law. Unless otherwise stated the results shown in this test report refer only to the sample(s) tested and such sample(s) are retained for 30 days only.  
**Attention: To check the authenticity of testing /inspection report & certificate, please contact us at telephone: (86-755) 8307 1443, or email: CN.Doccheck@sgs.com**

## 4 General Information

### 4.1 Details of EUT

Power Supply:	DC 38-58V
Test Voltage:	DC 48V
Cable:	N/A
Operating Temperature:	-40 to +55 °C
Operating Humidity:	≤95%
Frequency Range:	Uplink: 2496-2690MHz Downlink: 2496-2690MHz
Support Technology:	<input type="checkbox"/> GSM <input type="checkbox"/> WCDMA <input checked="" type="checkbox"/> LTE <input checked="" type="checkbox"/> 5G NR
Modulation Type:	PSK/QPSK/QAM/16QAM/64QAM/256QAM
Support Channel Bandwidth:	LTE 10MHz/20MHz 5G NR 10MHz/20MHz/40MHz/60MHz/80MHz/100MHz
Interface:	CPRI Port 2 (SFP+) Antenna Port 2 (4.3-10-Female, ANT1~ANT2) Power Jack 1 Debug Port 1 (RJ45)
Normal Output Power:	Maximum 24dBm (only downlink, per antenna port)
Maximum System Gain:	Uplink: 0dB Downlink: 0dB
EUT Configuration:	2T2R (2X2 MIMO, the internal circuit designs and the intend output power for each antenna port are identical, declared by the manufacturer)
Antenna Type:	External Dedicated Antenna
Permission Antenna Gain:	5dBi or less (declared by the manufacturer)
Software Version:	DLRUG2_V01.00.01.23



Unless otherwise agreed in writing, this document is issued by the Company subject to its General Conditions of Service printed overleaf, available on request or accessible at <http://www.sgs.com/en/Terms-and-Conditions.aspx> and, for electronic format documents, subject to Terms and Conditions for Electronic Documents at <http://www.sgs.com/en/Terms-and-Conditions/Terms-e-Documents.aspx>. Attention is drawn to the limitation of liability, indemnification and jurisdiction issues defined therein. Any holder of this document is advised that information contained hereon reflects the Company's findings at the time of its intervention only and within the limits of Client's instructions, if any. The Company's sole responsibility is to its Client and this document does not exonerate parties to a transaction from exercising all their rights and obligations under the transaction documents. This document cannot be reproduced except in full, without prior written approval of the Company. Any unauthorized alteration, forgery or falsification of the content or appearance of this document is unlawful and offenders may be prosecuted to the fullest extent of the law. Unless otherwise stated the results shown in this test report refer only to the sample(s) tested and such sample(s) are retained for 30 days only.

Attention: To check the authenticity of testing /inspection report & certificate, please contact us at telephone: (86-755) 8307 1443, or email: [CN.Doccheck@sgs.com](mailto:CN.Doccheck@sgs.com)

### 4.2 Description of Support Units

Description	Manufacturer	Model No.	Serial No.
Notebook	LENOVO	Lenovo Xiaoxinchao 5000	PF0TNMG8
Radio Interface Unit supporting 2.5G (RIU)	Supplied by client	RIU-G2-25	/
Digital Conversion Unit (DCU)	Supplied by client	DCU-G2	/
Distributed Extension Unit (DEU)	Supplied by client	DEU-G2	/

### 4.3 Test Environment

Environment Parameter	Selected Values During Test	
Relative Humidity	Ambient	
Value	Temperature (°C)	Voltage (V)
TNVN	Asmbient	DC 48V
TLVL	-30	DC 40.8V
TLVH	-30	DC 55.2V
THVL	+50	DC 40.8V
THVH	+50	DC 55.2V

VN: Normal Voltage

TN: Normal Temperature

VL: Lower Extreme Voltage

HL: Higher Extreme Voltage

TL: Lower Extreme Temperature

TH: Higher Extreme Temperature



Unless otherwise agreed in writing, this document is issued by the Company subject to its General Conditions of Service printed overleaf, available on request or accessible at <http://www.sgs.com/en/Terms-and-Conditions.aspx> and, for electronic format documents, subject to Terms and Conditions for Electronic Documents at <http://www.sgs.com/en/Terms-and-Conditions/Terms-e-Documents.aspx>. Attention is drawn to the limitation of liability, indemnification and jurisdiction issues defined therein. Any holder of this document is advised that information contained hereon reflects the Company's findings at the time of its intervention only and within the limits of Client's instructions, if any. The Company's sole responsibility is to its Client and this document does not exonerate parties to a transaction from exercising all their rights and obligations under the transaction documents. This document cannot be reproduced except in full, without prior written approval of the Company. Any unauthorized alteration, forgery or falsification of the content or appearance of this document is unlawful and offenders may be prosecuted to the fullest extent of the law. Unless otherwise stated the results shown in this test report refer only to the sample(s) tested and such sample(s) are retained for 30 days only.

Attention: To check the authenticity of testing /inspection report & certificate, please contact us at telephone: (86-755) 8307 1443, or email: [CN.Doccheck@sgs.com](mailto:CN.Doccheck@sgs.com)

#### 4.4 Test Signals and Channel

Test Channel	Test Frequency (MHz)	Test Signal	Stimulus Condition
LCH	2498.5	AWGN (4.1MHz 99% OBW)	a single test signal
MCH	2593		
HCH	2687.5		
LCH	2498.5, 2503.5	GSM-TDMA	two adjacent test signals
HCH	2682.5, 2687.5		
LCH	2496.2	GSM-TDMA	a single test signal
MCH	2593		
HCH	2689.8		
LCH	2496.2, 2496.4		two adjacent test signals
HCH	2689.6, 2689.8		

LCH: Lowest Channel

MCH: Middle Channel

HCH: Highest Channel

#### 4.5 Measurement Uncertainty

No.	Item	Measurement Uncertainty
1	RF Output Power	±0.75dB
2	Transmitter unwanted emissions	±0.75dB
3	Radiated Spurious Emission	±5.06dB (30MHz-1GHz; 3m); ±4.46dB (30MHz-1GHz; 10m); ±5.08dB (1GHz-6GHz); ±5.14dB (6GHz-18GHz)
4	Occupied Channel Bandwidth	± 3%

#### 4.6 Test Location

All tests were performed at:

SGS-CSTC Standards Technical Services Co., Ltd., Guangzhou Branch EMC Laboratory,  
198 Kezhu Road, Sciencetech Park, Guangzhou Economic & Technology Development District,  
Guangzhou, China 510663

Tel: +86 20 82155555

Fax: +86 20 82075059

No tests were sub-contracted.



Unless otherwise agreed in writing, this document is issued by the Company subject to its General Conditions of Service printed overleaf, available on request or accessible at <http://www.sgs.com/en/Terms-and-Conditions.aspx> and, for electronic format documents, subject to Terms and Conditions for Electronic Documents at <http://www.sgs.com/en/Terms-and-Conditions/Terms-e-Documents.aspx>. Attention is drawn to the limitation of liability, indemnification and jurisdiction issues defined therein. Any holder of this document is advised that information contained hereon reflects the Company's findings at the time of its intervention only and within the limits of Client's instructions, if any. The Company's sole responsibility is to its Client and this document does not exonerate parties to a transaction from exercising all their rights and obligations under the transaction documents. This document cannot be reproduced except in full, without prior written approval of the Company. Any unauthorized alteration, forgery or falsification of the content or appearance of this document is unlawful and offenders may be prosecuted to the fullest extent of the law. Unless otherwise stated the results shown in this test report refer only to the sample(s) tested and such sample(s) are retained for 30 days only.

Attention: To check the authenticity of testing / inspection report & certificate, please contact us at telephone: (86-755) 8307 1443, or email: [CN.Doccheck@sgs.com](mailto:CN.Doccheck@sgs.com)  
 No.198 Kezhu Road, Sciencetech Park, Guangzhou Economic & Technology Development District, Guangzhou, China 510663 t (86-20) 82155555 f (86-20) 82075058 www.sgs.com.cn  
 中国·广州·经济技术开发区科学城科珠路198号 邮编: 510663 t (86-20) 82155555 f (86-20) 82075058 sgs.china@sgs.com



#### 4.7 Test Facility

The test facility is recognized, certified, or accredited by the following organizations:

- **NVLAP (Lab Code: 200611-0)**

SGS-CSTC Standards Technical Services Co., Ltd., Guangzhou EMC Laboratory is accredited by the National Voluntary Laboratory Accreditation Program (NVLAP/NIST). NVLAP Code: 200611-0.

The report must not be used by the client to claim product certification, approval, or endorsement by NVLAP, NIST, or any agency of the Federal Government.

- **ACMA**

SGS-CSTC Standards Technical Services Co., Ltd., EMC Laboratory can also perform testing for the Australian/New Zealand Regulatory Compliance Mark (RCM).

- **SGS UK(Certificate No.: 32), SGS-TUV SAARLAND and SGS-FIMKO**

Have approved SGS-CSTC Standards Technical Services Co., Ltd., EMC Laboratory as a supplier of EMC TESTING SERVICES and SAFETY TESTING SERVICES.

- **CNAS (Lab Code: L0167)**

SGS-CSTC Standards Technical Services Co., Ltd., EMC Laboratory has been assessed and in compliance with CNAS-CL01:2018 accreditation criteria for testing laboratories (identical to ISO/IEC 17025:2017 General Requirements) for the Competence of Testing Laboratories.

- **FCC Recognized Accredited Test Firm(Registration No.: 486818)**

SGS-CSTC Standards Technical Services Co., Ltd., EMC Laboratory has been accredited and fully described in a report filed with the (FCC) Federal Communications Commission. The acceptance letter from the FCC is maintained in our files. Designation Number: CN5016, Test Firm Registration Number: 486818.

- **ISED (Registration No.: 4620B, CAB identifier: CN0052)**

SGS-CSTC Standards Technical Services Co., Ltd., has been registered by Innovation Science and Economic Development Canada for Wireless Device Testing laboratories to test to Canadian radio equipment requirements. Registration No. 4620B, CAB identifier: CN0052.

- **VCCI (Registration No.: R-12460, C-12584, G-20107 and T-11179)**

The 10m Semi-anechoic chamber, 966 Anechoic Chamber and Shielded Room of SGS-CSTC Standards Technical Services Co., Ltd. have been registered in accordance with the Regulations for Voluntary Control Measures with Registration No.: R-12460, C-12584, G-20107 and T-11179 respectively.

- **CBTL (Lab Code: TL129)**

SGS-CSTC Standards Technical Services Co., Ltd., E&E Laboratory has been assessed and fully comply with the requirements of ISO/IEC 17025:2017, the Basic Rules, IECCE 01 and Rules of procedure IECCE 02, and the relevant IECCE CB-Scheme Operational documents.

#### 4.8 Deviation from Standards

None

#### 4.9 Abnormalities from Standard Conditions

None



Unless otherwise agreed in writing, this document is issued by the Company subject to its General Conditions of Service printed overleaf, available on request or accessible at <http://www.sgs.com/en/Terms-and-Conditions.aspx> and, for electronic format documents, subject to Terms and Conditions for Electronic Documents at <http://www.sgs.com/en/Terms-and-Conditions/Terms-e-Documents.aspx>. Attention is drawn to the limitation of liability, indemnification and jurisdiction issues defined therein. Any holder of this document is advised that information contained hereon reflects the Company's findings at the time of its intervention only and within the limits of Client's instructions, if any. The Company's sole responsibility is to its Client and this document does not exonerate parties to a transaction from exercising all their rights and obligations under the transaction documents. This document cannot be reproduced except in full, without prior written approval of the Company. Any unauthorized alteration, forgery or falsification of the content or appearance of this document is unlawful and offenders may be prosecuted to the fullest extent of the law. Unless otherwise stated the results shown in this test report refer only to the sample(s) tested and such sample(s) are retained for 30 days only.

Attention: To check the authenticity of testing /inspection report & certificate, please contact us at telephone: (86-755) 8307 1443, or email: [CN.Doccheck@sgs.com](mailto:CN.Doccheck@sgs.com)

## 5 Equipment List

Conducted test equipment					
Equipment	Manufacturer	Model No	Inventory No	Cal Date	Cal Due Date
Temperature Chamber	GZ GongWen Co.Ltd.	GDJW-100	EMC0039	2022-07-04	2023-07-03
MI CABLE	SGS-EMC	0.8M	EMC2137	2021-11-02	2023-11-01
MI CABLE	SGS-EMC	0.8M	EMC2136	2021-11-02	2023-11-01
EXA Signal Analyzer (10Hz-44GHz)	Keysight	N9010A	EMC2138	2021-09-20	2022-09-19
Test Software	TST	V2.0	GZE100-78	N/A	N/A
ESG vector signal generator (250kHz-6GHz)	Agilent Technologies	E4438C	SEM006-03	2022-03-03	2023-03-02

Radiated test equipment (30MHz to 1GHz)					
Equipment	Manufacturer	Model No	Inventory No	Cal Date	Cal Due Date
EMI Test Receiver (10Hz-26.5GHz)	Rohde & Schwarz	ESIB26	EMC0522	2021-12-17	2022-12-16
10m Semi-Anechoic Chamber	ETS	N/A	EMC0530	2019-10-20	2022-10-19
Chamber cable	HangTianXing	N/A	EMC0542	2020-09-09	2022-09-08
Amplifier (9kHz-1.3GHz)	HP	8447F	EMC2065	2022-06-21	2023-06-20
Test Software E3	Audix	Ver.6.120110a	GZE100-61	N/A	N/A
Trilog Broadband Antenna (25MHz-2GHz)	SCHWARZBECK	VULB 9168	SEM003-18	2022-03-03	2025-03-02
Trilog Broadband Antenna (25MHz-2GHz)	SCHWARZBECK	VULB 9168	EMC2174	2022-06-19	2025-06-18



Unless otherwise agreed in writing, this document is issued by the Company subject to its General Conditions of Service printed overleaf, available on request or accessible at <http://www.sgs.com/en/Terms-and-Conditions.aspx> and, for electronic format documents, subject to Terms and Conditions for Electronic Documents at <http://www.sgs.com/en/Terms-and-Conditions/Terms-e-Documents.aspx>. Attention is drawn to the limitation of liability, indemnification and jurisdiction issues defined therein. Any holder of this document is advised that information contained hereon reflects the Company's findings at the time of its intervention only and within the limits of Client's instructions, if any. The Company's sole responsibility is to its Client and this document does not exonerate parties to a transaction from exercising all their rights and obligations under the transaction documents. This document cannot be reproduced except in full, without prior written approval of the Company. Any unauthorized alteration, forgery or falsification of the content or appearance of this document is unlawful and offenders may be prosecuted to the fullest extent of the law. Unless otherwise stated the results shown in this test report refer only to the sample(s) tested and such sample(s) are retained for 30 days only.

Attention: To check the authenticity of testing /inspection report & certificate, please contact us at telephone: (86-755) 8307 1443, or email: [CN.Doccheck@sgs.com](mailto:CN.Doccheck@sgs.com)

<b>Radiated test equipment (above 1GHz)</b>					
<b>Equipment</b>	<b>Manufacturer</b>	<b>Model No</b>	<b>Inventory No</b>	<b>Cal Date</b>	<b>Cal Due Date</b>
1GHz-26.5 GHz Pre-Amplifier	Agilent	8449B	EMC0521	2021-12-17	2022-12-16
Microwave Broadband Preamplifier (18-40GHz)	SCHWARZBECK	BBV 9721	EMC2172	2021-08-30	2022-08-29
EMI Test Receiver (10Hz-26.5GHz)	Rohde & Schwarz	ESIB26	EMC0522	2021-12-17	2022-12-16
EXA Signal Analyzer (10Hz-44GHz)	Keysight	N9010A	EMC2138	2021-09-20	2022-09-19
Chamber cable (Above 1GHz)	Scoflex	KMKM-8.0m	EMC0545	2020-09-09	2022-09-08
Chamber Cable (Below 1GHz)	Scoflex	KMKM-8.0m	EMC0546	2022-01-06	2024-01-05
Horn Antenna (1GHz-18GHz)	SCHWARZBECK	BBHA 9120D	EMC2026	2019-09-25	2022-09-24
Horn Antenna 1-18GHz	SCHWARZBECK MESS-ELEKTRONIK	BBHA 9120D	EMC2251	2022-02-02	2025-08-01
Horn Antenna (14-40GHz)	SCHWARZBECK	BBHA 9170	EMC2041	2020-06-28	2023-06-27
Broad-Band Horn Antenna (15-40GHz)	Schwarzbeck	BBHA 9170	SEM003-15	2021-7-11	2024-7-10
966 Anechoic Chamber	C.R.T	9m x 6m x 6m	EMC2142	2020-12-20	2023-12-19
Test Software E3	Audix	Ver.6.120110a	GZE100-61	N/A	N/A



Unless otherwise agreed in writing, this document is issued by the Company subject to its General Conditions of Service printed overleaf, available on request or accessible at <http://www.sgs.com/en/Terms-and-Conditions.aspx> and, for electronic format documents, subject to Terms and Conditions for Electronic Documents at <http://www.sgs.com/en/Terms-and-Conditions/Terms-e-Documents.aspx>. Attention is drawn to the limitation of liability, indemnification and jurisdiction issues defined therein. Any holder of this document is advised that information contained hereon reflects the Company's findings at the time of its intervention only and within the limits of Client's instructions, if any. The Company's sole responsibility is to its Client and this document does not exonerate parties to a transaction from exercising all their rights and obligations under the transaction documents. This document cannot be reproduced except in full, without prior written approval of the Company. Any unauthorized alteration, forgery or falsification of the content or appearance of this document is unlawful and offenders may be prosecuted to the fullest extent of the law. Unless otherwise stated the results shown in this test report refer only to the sample(s) tested and such sample(s) are retained for 30 days only.

Attention: To check the authenticity of testing /inspection report & certificate, please contact us at telephone: (86-755) 8307 1443, or email: [CN.Doccheck@sgs.com](mailto:CN.Doccheck@sgs.com)

## 6 Radio Spectrum Matter Test Results

### 6.1 Out-of-band rejection

Test Requirement: KDB 935210 D05 clause 3.3

Test Method: KDB 935210 D05 clause 3.3

Limit: Within the passband

#### 6.1.1 E.U.T. Operation

Operating Environment:

Temperature: 25.2 °C Humidity: 60 % RH Atmospheric Pressure: 1020 mbar

EUT Operation: Drive the EUT to the maximum output power at maximum gain.

#### 6.1.2 Test Setup

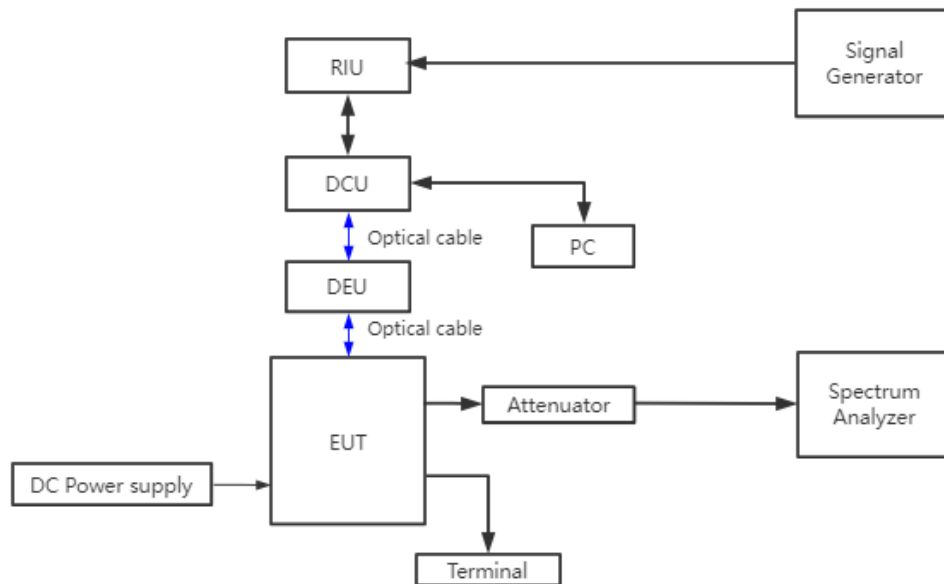

Unless otherwise agreed in writing, this document is issued by the Company subject to its General Conditions of Service printed overleaf, available on request or accessible at <http://www.sgs.com/en/Terms-and-Conditions.aspx> and, for electronic format documents, subject to Terms and Conditions for Electronic Documents at <http://www.sgs.com/en/Terms-and-Conditions/Terms-e-Documents.aspx>. Attention is drawn to the limitation of liability, indemnification and jurisdiction issues defined therein. Any holder of this document is advised that information contained hereon reflects the Company's findings at the time of its intervention only and within the limits of Client's instructions, if any. The Company's sole responsibility is to its Client and this document does not exonerate parties to a transaction from exercising all their rights and obligations under the transaction documents. This document cannot be reproduced except in full, without prior written approval of the Company. Any unauthorized alteration, forgery or falsification of the content or appearance of this document is unlawful and offenders may be prosecuted to the fullest extent of the law. Unless otherwise stated the results shown in this test report refer only to the sample(s) tested and such sample(s) are retained for 30 days only.

### 6.1.3 Test Procedure

Adjust the internal gain control of the EUT to the maximum gain for which equipment certification is sought.

- a) Connect a signal generator to the input of the EUT.
- b) Configure a swept CW signal with the following parameters:
  - 1) Frequency range =  $\pm 250\%$  of the manufacturer's specified pass band.
  - 2) The CW amplitude shall be 3 dB below the AGC threshold and shall not activate the AGC threshold throughout the test.
  - 3) Dwell time = approximately 10 ms.
  - 4) Frequency step = 50 kHz.
- c) Connect a spectrum analyzer to the output of the EUT using appropriate attenuation.
- d) Set the RBW of the spectrum analyzer to between 1% and 5% of the manufacturer's pass band with the VBW set to  $3 \times$  RBW.
- e) Set the detector to Peak and the trace to Max-Hold.
- f) After the trace is completely filled place a marker at the peak amplitude which is designated as  $f_0$ , with two additional markers (use the marker delta method) at the 20 dB bandwidth (i.e., at the points where the level has fallen by 20 dB).
- g) Capture the frequency response plot for inclusion in the test report.

### 6.1.4 Measurement Record

Please refer to Appendix - Test Data and Result for report GZCR220800101302.



Unless otherwise agreed in writing, this document is issued by the Company subject to its General Conditions of Service printed overleaf, available on request or accessible at <http://www.sgs.com/en/Terms-and-Conditions.aspx> and, for electronic format documents, subject to Terms and Conditions for Electronic Documents at <http://www.sgs.com/en/Terms-and-Conditions/Terms-e-Documents.aspx>. Attention is drawn to the limitation of liability, indemnification and jurisdiction issues defined therein. Any holder of this document is advised that information contained hereon reflects the Company's findings at the time of its intervention only and within the limits of Client's instructions, if any. The Company's sole responsibility is to its Client and this document does not exonerate parties to a transaction from exercising all their rights and obligations under the transaction documents. This document cannot be reproduced except in full, without prior written approval of the Company. Any unauthorized alteration, forgery or falsification of the content or appearance of this document is unlawful and offenders may be prosecuted to the fullest extent of the law. Unless otherwise stated the results shown in this test report refer only to the sample(s) tested and such sample(s) are retained for 30 days only.  
Attention: To check the authenticity of testing /inspection report & certificate, please contact us at telephone: (86-755) 8307 1443, or email: [CN.Doccheck@sgs.com](mailto:CN.Doccheck@sgs.com)

### 6.2 Input versus output comparison

Test Requirement: 47 CFR Part 2.1049  
 Test Method: KDB 935210 D05 clause 3.4  
 Limit: The spectral plots of the output signal and the input signal are similar (in passband and rolloff characteristic features and relative spectral locations).

#### 6.2.1 E.U.T. Operation

Operating Environment:  
 Temperature: 25.2 °C Humidity: 60 % RH Atmospheric Pressure: 1020 mbar  
 EUT Operation: Drive the EUT to the maximum output power at maximum gain.

#### 6.2.2 Test Setup

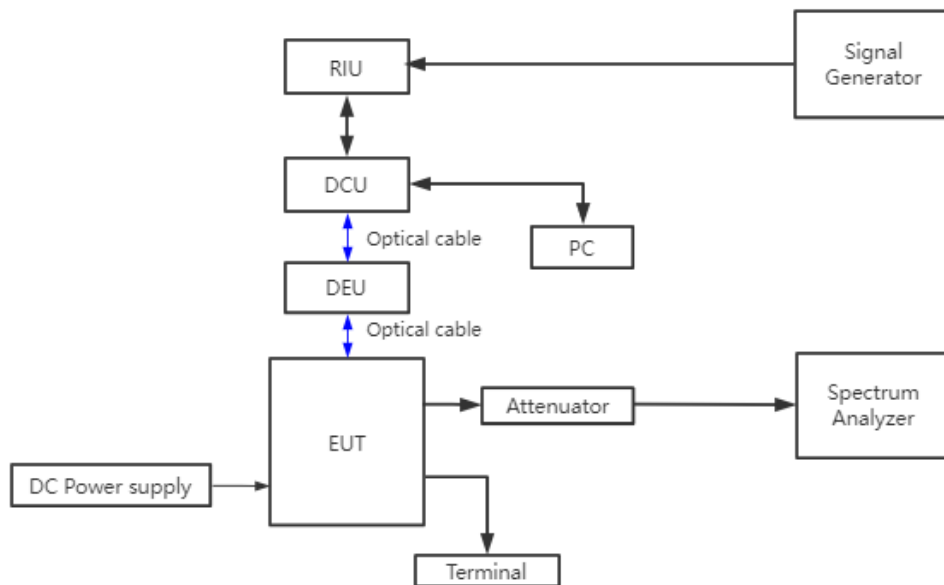

Unless otherwise agreed in writing, this document is issued by the Company subject to its General Conditions of Service printed overleaf, available on request or accessible at <http://www.sgs.com/en/Terms-and-Conditions.aspx> and, for electronic format documents, subject to Terms and Conditions for Electronic Documents at <http://www.sgs.com/en/Terms-and-Conditions/Terms-e-Documents.aspx>. Attention is drawn to the limitation of liability, indemnification and jurisdiction issues defined therein. Any holder of this document is advised that information contained hereon reflects the Company's findings at the time of its intervention only and within the limits of Client's instructions, if any. The Company's sole responsibility is to its Client and this document does not exonerate parties to a transaction from exercising all their rights and obligations under the transaction documents. This document cannot be reproduced except in full, without prior written approval of the Company. Any unauthorized alteration, forgery or falsification of the content or appearance of this document is unlawful and offenders may be prosecuted to the fullest extent of the law. Unless otherwise stated the results shown in this test report refer only to the sample(s) tested and such sample(s) are retained for 30 days only.  
 Attention: To check the authenticity of testing / inspection report & certificate, please contact us at telephone: (86-755) 8307 1443, or email: [CN.Doccheck@sgs.com](mailto:CN.Doccheck@sgs.com)

### 6.2.3 Test Procedure

A 26 dB bandwidth measurement shall be performed on the input signal and the output signal; alternatively, the 99% OBW can be measured and used. See KDB Publication 971168 [R8] for more information on measuring OBW.

- a) Connect a signal generator to the input of the EUT.
- b) Configure the signal generator to transmit the AWGN signal.
- c) Configure the signal amplitude to be just below the AGC threshold level (see 3.2), but not more than 0.5 dB below.
- d) Connect a spectrum analyzer to the output of the EUT using appropriate attenuation.
- e) Set the spectrum analyzer center frequency to the center frequency of the operational band under test. The span range of the spectrum analyzer shall be between  $2 \times$  to  $5 \times$  the emission bandwidth (EBW) or alternatively, the OBW.
- f) The nominal RBW shall be in the range of 1 % to 5 % of the anticipated OBW, and the VBW shall be  $\geq 3 \times$  RBW.
- g) Set the reference level of the instrument as required to preclude the signal from exceeding the maximum spectrum analyzer input mixer level for linear operation. In general, the peak of the spectral envelope must be more than  $[10 \log (OBW / RBW)]$  below the reference level. Steps f) and g) may require iteration to enable adjustments within the specified tolerances.
- h) The noise floor of the spectrum analyzer at the selected RBW shall be at least 36 dB below the reference level.
- i) Set spectrum analyzer detection function to positive peak.
- j) Set the trace mode to max hold.
- k) Determine the reference value: Allow the trace to stabilize. Set the spectrum analyzer marker to the highest amplitude level of the displayed trace (this is the reference value) and record the associated frequency.
- l) Place two markers, one at the lowest and the other at the highest frequency of the envelope of the spectral display, such that each marker is at or slightly below the  $-26$  dB down amplitude. The 26 dB EBW (alternatively OBW) is the positive frequency difference between the two markers. If the spectral envelope crosses the  $-26$  dB down amplitude at multiple points, the lowest or highest frequency shall be selected as the frequencies that are the furthest removed from the center frequency at which the spectral envelope crosses the  $-26$  dB down amplitude point.
- m) Repeat steps e) to l) with the input signal connected directly to the spectrum analyzer (i.e., input signal measurement).
- n) Compare the spectral plot of the input signal (determined from step m) to the output signal (determined from step l) to affirm that they are similar (in passband and rolloff characteristic features and relative spectral locations), and include plot(s) and descriptions in test report.
- o) Repeat the procedure [steps e) to n)] with the input signal amplitude set to 3 dB above the AGC threshold.
- p) Repeat steps e) to o) with the signal generator set to the narrowband signal.
- q) Repeat steps e) to p) for all frequency bands authorized for use by the EUT.

### 6.2.4 Measurement Record

Please refer to Appendix - Test Data and Result for report GZCR220800101302.



Unless otherwise agreed in writing, this document is issued by the Company subject to its General Conditions of Service printed overleaf, available on request or accessible at <http://www.sgs.com/en/Terms-and-Conditions.aspx> and, for electronic format documents, subject to Terms and Conditions for Electronic Documents at <http://www.sgs.com/en/Terms-and-Conditions/Terms-e-Documents.aspx>. Attention is drawn to the limitation of liability, indemnification and jurisdiction issues defined therein. Any holder of this document is advised that information contained hereon reflects the Company's findings at the time of its intervention only and within the limits of Client's instructions, if any. The Company's sole responsibility is to its Client and this document does not exonerate parties to a transaction from exercising all their rights and obligations under the transaction documents. This document cannot be reproduced except in full, without prior written approval of the Company. Any unauthorized alteration, forgery or falsification of the content or appearance of this document is unlawful and offenders may be prosecuted to the fullest extent of the law. Unless otherwise stated the results shown in this test report refer only to the sample(s) tested and such sample(s) are retained for 30 days only.

Attention: To check the authenticity of testing / inspection report & certificate, please contact us at telephone: (86-755) 8307 1443, or email: [CN.Doccheck@sgs.com](mailto:CN.Doccheck@sgs.com)

### 6.3 Mean output power and amplifier/booster gain

Test Requirement: 47 CFR Part 27.50(h)

Test Method: KDB 935210 D05 clause 3.5

Limit: For main or booster station sectorizes or otherwise uses one or more transmitting antennas with a non-omnidirectional horizontal plane radiation pattern:  
 $EIRP \leq 33dBW + 10\lg(X/Y) \text{ dBW} + 10\lg(360/\text{beamwidth}) \text{ dBW}$   
 For other main or booster:  
 $EIRP \leq 33dBW + 10\lg(X/Y) \text{ dBW}$   
 where X is the actual channel width in MHz and Y is either 6 MHz if prior to transition or the station is in the MBS following transition or 5.5 MHz if the station is in the LBS and UBS following transition

#### 6.3.1 E.U.T. Operation

Operating Environment:

Temperature: 25.2 °C Humidity: 60 % RH Atmospheric Pressure: 1020 mbar

EUT Operation: Drive the EUT to the maximum output power at maximum gain.

#### 6.3.2 Test Setup

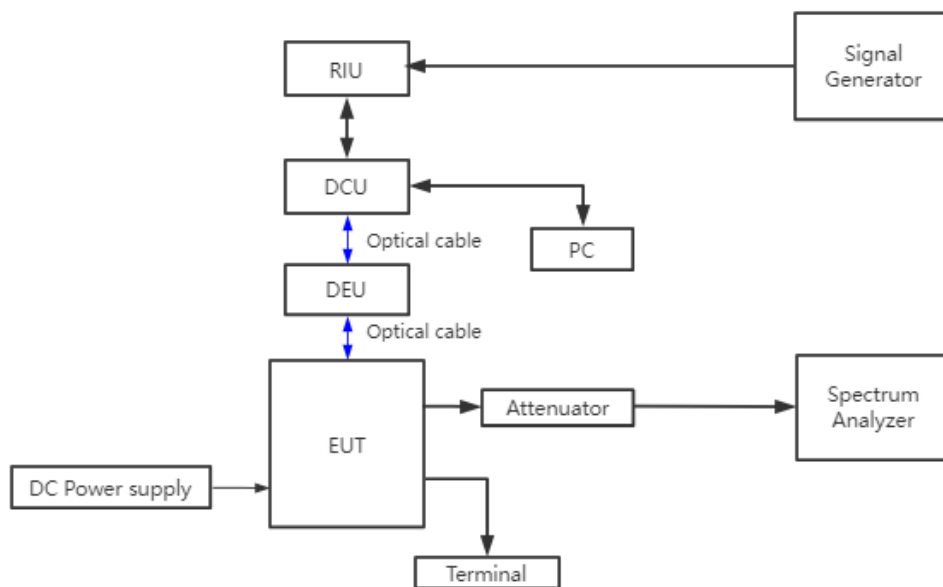

Unless otherwise agreed in writing, this document is issued by the Company subject to its General Conditions of Service printed overleaf, available on request or accessible at <http://www.sgs.com/en/Terms-and-Conditions.aspx> and, for electronic format documents, subject to Terms and Conditions for Electronic Documents at <http://www.sgs.com/en/Terms-and-Conditions/Terms-e-Documents.aspx>. Attention is drawn to the limitation of liability, indemnification and jurisdiction issues defined therein. Any holder of this document is advised that information contained hereon reflects the Company's findings at the time of its intervention only and within the limits of Client's instructions, if any. The Company's sole responsibility is to its Client and this document does not exonerate parties to a transaction from exercising all their rights and obligations under the transaction documents. This document cannot be reproduced except in full, without prior written approval of the Company. Any unauthorized alteration, forgery or falsification of the content or appearance of this document is unlawful and offenders may be prosecuted to the fullest extent of the law. Unless otherwise stated the results shown in this test report refer only to the sample(s) tested and such sample(s) are retained for 30 days only.

Attention: To check the authenticity of testing /inspection report & certificate, please contact us at telephone: (86-755) 8307 1443, or email: [CN.Doccheck@sgs.com](mailto:CN.Doccheck@sgs.com)



### 6.3.3 Test Procedure

- a) Connect a signal generator to the input of the EUT.
- b) Configure to generate the AWGN (broadband) test signal.
- c) The frequency of the signal generator shall be set to the frequency  $f_0$  as determined from 3.3.
- d) Connect a spectrum analyzer or power meter to the output of the EUT using appropriate attenuation as necessary.
- e) Set the signal generator output power to a level that produces an EUT output level that is just below the AGC threshold (see 3.2), but not more than 0.5 dB below.
- f) Measure and record the output power of the EUT; use 3.5.3 or 3.5.4 for power measurement.
- g) Remove the EUT from the measurement setup. Using the same signal generator settings, repeat the power measurement at the signal generator port, which was used as the input signal to the EUT, and record as the input power. EUT gain may be calculated as described in 3.5.5.
- h) Repeat steps f) and g) with input signal amplitude set to 3 dB above the AGC threshold level.
- i) Repeat steps e) to h) with the narrowband test signal.
- j) Repeat steps e) to i) for all frequency bands authorized for use by the EUT.
- h) After the mean input and output power levels have been measured as described in the preceding subclauses, the mean gain of the EUT can be determined from:  
$$\text{Gain (dB)} = \text{output power (dBm)} - \text{input power (dBm)}.$$
Report the mean gain for each authorized operating frequency band and each test signal stimulus.

### 6.3.4 Measurement Record

Please refer to Appendix - Test Data and Result for report GZCR220800101302.



Unless otherwise agreed in writing, this document is issued by the Company subject to its General Conditions of Service printed overleaf, available on request or accessible at <http://www.sgs.com/en/Terms-and-Conditions.aspx> and, for electronic format documents, subject to Terms and Conditions for Electronic Documents at <http://www.sgs.com/en/Terms-and-Conditions/Terms-e-Documents.aspx>. Attention is drawn to the limitation of liability, indemnification and jurisdiction issues defined therein. Any holder of this document is advised that information contained hereon reflects the Company's findings at the time of its intervention only and within the limits of Client's instructions, if any. The Company's sole responsibility is to its Client and this document does not exonerate parties to a transaction from exercising all their rights and obligations under the transaction documents. This document cannot be reproduced except in full, without prior written approval of the Company. Any unauthorized alteration, forgery or falsification of the content or appearance of this document is unlawful and offenders may be prosecuted to the fullest extent of the law. Unless otherwise stated the results shown in this test report refer only to the sample(s) tested and such sample(s) are retained for 30 days only.

Attention: To check the authenticity of testing /inspection report & certificate, please contact us at telephone: (86-755) 8307 1443, or email: [CN.Doccheck@sgs.com](mailto:CN.Doccheck@sgs.com)

### 6.4 Out-of-band/out-of-block(including intermodulation) emissions

Test Requirement: 47 CFR Part 27.53(m)  
 Test Method: KDB 935210 D05 clause 3.6  
 Limit: For digital base stations, the attenuation shall be not less than  $43 + 10 \log (P)$  dB, unless a documented interference complaint is received from an adjacent channel licensee with an overlapping Geographic Service Area.

#### 6.4.1 E.U.T. Operation

Operating Environment:  
 Temperature: 25.2 °C Humidity: 60 % RH Atmospheric Pressure: 1020 mbar  
 EUT Operation: Drive the EUT to the maximum output power at maximum gain.

#### 6.4.2 Test Setup

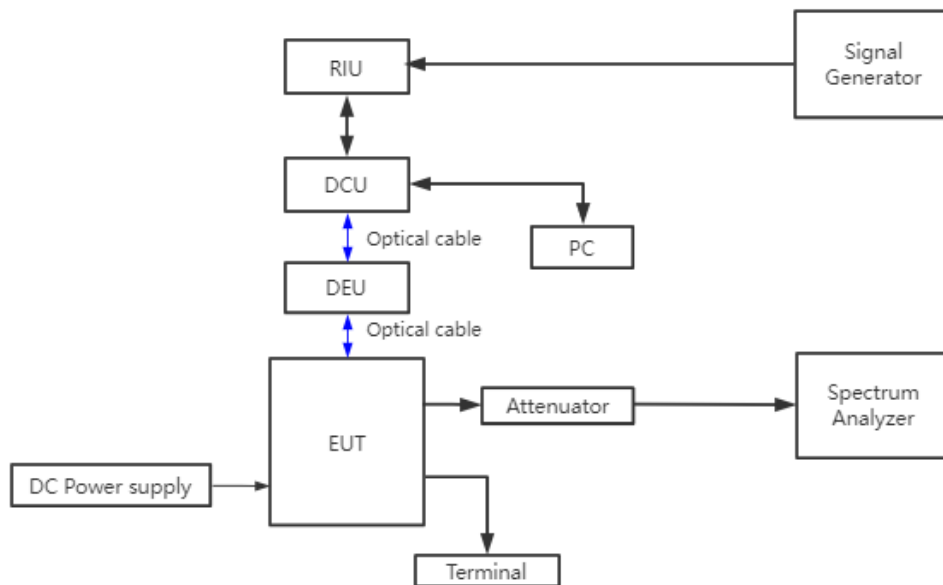

Unless otherwise agreed in writing, this document is issued by the Company subject to its General Conditions of Service printed overleaf, available on request or accessible at <http://www.sgs.com/en/Terms-and-Conditions.aspx> and, for electronic format documents, subject to Terms and Conditions for Electronic Documents at <http://www.sgs.com/en/Terms-and-Conditions/Terms-e-Document.aspx>. Attention is drawn to the limitation of liability, indemnification and jurisdiction issues defined therein. Any holder of this document is advised that information contained hereon reflects the Company's findings at the time of its intervention only and within the limits of Client's instructions, if any. The Company's sole responsibility is to its Client and this document does not exonerate parties to a transaction from exercising all their rights and obligations under the transaction documents. This document cannot be reproduced except in full, without prior written approval of the Company. Any unauthorized alteration, forgery or falsification of the content or appearance of this document is unlawful and offenders may be prosecuted to the fullest extent of the law. Unless otherwise stated the results shown in this test report refer only to the sample(s) tested and such sample(s) are retained for 30 days only.  
 Attention: To check the authenticity of testing /inspection report & certificate, please contact us at telephone: (86-755) 8307 1443, or email: [CN.Doccheck@sgs.com](mailto:CN.Doccheck@sgs.com)

### 6.4.3 Test Procedure

- a) Connect a signal generator to the input of the EUT.  
If the signal generator is not capable of generating two modulated carriers simultaneously, then two discrete signal generators can be connected with an appropriate combining network to support this two-signal test.
- b) Set the signal generator to produce two AWGN signals as previously described (e.g., 4.1 MHz OBW). Set the signal generator amplitudes so that the power from each into the EUT is equivalent.
- c) Set the center frequencies such that the AWGN signals occupy adjacent channels, as defined by industry standards such as 3GPP or 3GPP2, at the upper edge of the frequency band or block under test.
- d) Set the composite power levels such that the input signal is just below the AGC threshold (see 3.2), but not more than 0.5 dB below. The composite power can be measured using the procedures provided in KDB Publication 971168 [R8], but it will be necessary to expand the power integration bandwidth so as to include both of the transmit channels. Alternatively, the composite power can be measured using an average power meter as described in KDB Publication 971168 [R8].
- e) Connect a spectrum analyzer to the output of the EUT using appropriate attenuation as necessary.
- f) Set the RBW = reference bandwidth in the applicable rule section for the supported frequency band (typically 1 % of the EBW or 100 kHz or 1 MHz)
- g) Set the VBW = 3 × RBW.
- h) Set the detector to power averaging (rms) detector.
- i) Set the Sweep time = auto-couple.
- j) Set the spectrum analyzer start frequency to the upper block edge frequency, and the stop frequency to the upper block edge frequency plus 300 kHz or 3 MHz, for frequencies below and above 1 GHz, respectively.
- k) Trace average at least 100 traces in power averaging (rms) mode.
- l) Use the marker function to find the maximum power level.
- m) Capture the spectrum analyzer trace of the power level for inclusion in the test report.
- n) Repeat steps k) to m) with the composite input power level set to 3 dB above the AGC threshold.
- o) Reset the frequencies of the input signals to the lower edge of the frequency block or band under test.
- p) Reset the spectrum analyzer start frequency to the lower block edge frequency minus 300 kHz or 3 MHz, for frequencies below and above 1 GHz, respectively, and the stop frequency to the lower band or block edge frequency.
- q) Repeat steps k) to n).
- r) Repeat steps a) to q) with the signal generator configured for a single test signal tuned as close as possible to the block edges.
- s) Repeat steps a) to r) with the narrowband test signal.
- t) Repeat steps a) to s) for all authorized frequency bands or blocks used by the EUT.

### 6.4.4 Measurement Record

Please refer to Appendix - Test Data and Result for report GZCR220800101302.



Unless otherwise agreed in writing, this document is issued by the Company subject to its General Conditions of Service printed overleaf, available on request or accessible at <http://www.sgs.com/en/Terms-and-Conditions.aspx> and, for electronic format documents, subject to Terms and Conditions for Electronic Documents at <http://www.sgs.com/en/Terms-and-Conditions/Terms-e-Documents.aspx>. Attention is drawn to the limitation of liability, indemnification and jurisdiction issues defined therein. Any holder of this document is advised that information contained hereon reflects the Company's findings at the time of its intervention only and within the limits of Client's instructions, if any. The Company's sole responsibility is to its Client and this document does not exonerate parties to a transaction from exercising all their rights and obligations under the transaction documents. This document cannot be reproduced except in full, without prior written approval of the Company. Any unauthorized alteration, forgery or falsification of the content or appearance of this document is unlawful and offenders may be prosecuted to the fullest extent of the law. Unless otherwise stated the results shown in this test report refer only to the sample(s) tested and such sample(s) are retained for 30 days only.  
Attention: To check the authenticity of testing /inspection report & certificate, please contact us at telephone: (86-755) 8307 1443, or email: [CN.Doccheck@sgs.com](mailto:CN.Doccheck@sgs.com)

### 6.5 Conducted Spurious emissions

Test Requirement: 47 CFR Part 27.53(m)  
 Test Method: KDB 935210 D05 clause 3.6  
 Limit: For digital base stations, the attenuation shall be not less than  $43 + 10 \log (P)$  dB, unless a documented interference complaint is received from an adjacent channel licensee with an overlapping Geographic Service Area.

#### 6.5.1 E.U.T. Operation

Operating Environment:  
 Temperature: 25.2 °C Humidity: 60 % RH Atmospheric Pressure: 1020 mbar  
 EUT Operation: Drive the EUT to the maximum output power at maximum gain.

#### 6.5.2 Test Setup

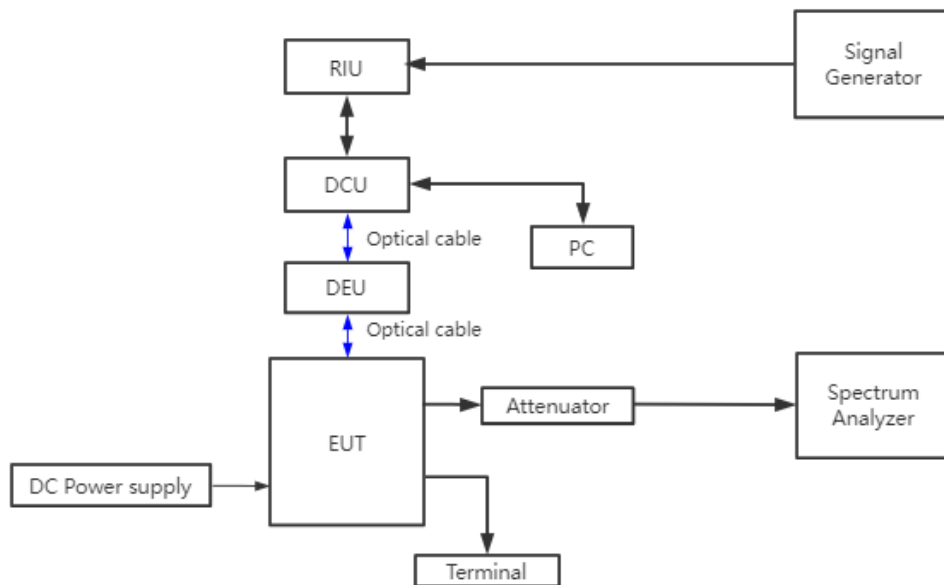

Unless otherwise agreed in writing, this document is issued by the Company subject to its General Conditions of Service printed overleaf, available on request or accessible at <http://www.sgs.com/en/Terms-and-Conditions.aspx> and, for electronic format documents, subject to Terms and Conditions for Electronic Documents at <http://www.sgs.com/en/Terms-and-Conditions/Terms-e-Documents.aspx>. Attention is drawn to the limitation of liability, indemnification and jurisdiction issues defined therein. Any holder of this document is advised that information contained hereon reflects the Company's findings at the time of its intervention only and within the limits of Client's instructions, if any. The Company's sole responsibility is to its Client and this document does not exonerate parties to a transaction from exercising all their rights and obligations under the transaction documents. This document cannot be reproduced except in full, without prior written approval of the Company. Any unauthorized alteration, forgery or falsification of the content or appearance of this document is unlawful and offenders may be prosecuted to the fullest extent of the law. Unless otherwise stated the results shown in this test report refer only to the sample(s) tested and such sample(s) are retained for 30 days only.  
 Attention: To check the authenticity of testing /inspection report & certificate, please contact us at telephone: (86-755) 8307 1443, or email: [CN.Doccheck@sgs.com](mailto:CN.Doccheck@sgs.com)

### 6.5.3 Test Procedure

- a) Connect a signal generator to the input of the EUT.
- b) Set the signal generator to produce the broadband test signal as previously described (i.e., 4.1 MHz OBW AWGN).
- c) Set the center frequency of the test signal to the lowest available channel within the frequency band or block.
- d) Set the EUT input power to a level that is just below the AGC threshold (see 3.2), but not more than 0.5 dB below.
- e) Connect a spectrum analyzer to the output of the EUT using appropriate attenuation as necessary.
- f) Set the RBW = reference bandwidth in the applicable rule section for the supported frequency band of operation (e.g., reference bandwidth is typically 100 kHz or 1 MHz).
- g) Set the VBW  $\geq 3 \times$  RBW.
- h) Set the Sweep time = auto-couple.
- i) Set the spectrum analyzer start frequency to the lowest RF signal generated in the equipment, without going below 9 kHz, and the stop frequency to the lower band/block edge frequency minus 100 kHz or 1 MHz, as specified in the applicable rule part.

The number of measurement points in each sweep must be  $\geq (2 \times \text{span}/\text{RBW})$ , which may require that the measurement range defined by the start and stop frequencies be subdivided, depending on the available number of measurement points provided by the spectrum analyzer.

- j) Select the power averaging (rms) detector function.
- k) Trace average at least 10 traces in power averaging (rms) mode.
- l) Use the peak marker function to identify the highest amplitude level over each measured frequency range. Record the frequency and amplitude and capture a plot for inclusion in the test report.
- m) Reset the spectrum analyzer start frequency to the upper band/block edge frequency plus 100 kHz or 1 MHz, as specified in the applicable rule part, and the spectrum analyzer stop frequency to  $10 \times$  the highest frequency of the fundamental emission (see Section 2.1057). The number of measurement points in each sweep must be  $\geq (2 \times \text{span}/\text{RBW})$ , which may require that the measurement range defined by the start and stop frequencies be subdivided, depending on the available number of measurement points provided by the spectrum analyzer.
- n) Trace average at least 10 traces in power averaging (rms) mode.
- o) Use the peak marker function to identify the highest amplitude level over each of the measured frequency ranges. Record the frequency and amplitude and capture a plot for inclusion in the test report; also provide tabular data, if required.
- p) Repeat steps i) to o) with the input test signals firstly tuned to a middle band/block frequency/channel, and then tuned to a high band/block frequency/channel.
- q) Repeat steps c) to p) with the narrowband test signal.
- r) Repeat steps b) to q) for all authorized frequency bands/blocks used by the EUT.

### 6.5.4 Measurement Record

Please refer to Appendix - Test Data and Result for report GZCR220800101302.



Unless otherwise agreed in writing, this document is issued by the Company subject to its General Conditions of Service printed overleaf, available on request or accessible at <http://www.sgs.com/en/Terms-and-Conditions.aspx> and, for electronic format documents, subject to Terms and Conditions for Electronic Documents at <http://www.sgs.com/en/Terms-and-Conditions/Terms-e-Documents.aspx>. Attention is drawn to the limitation of liability, indemnification and jurisdiction issues defined therein. Any holder of this document is advised that information contained hereon reflects the Company's findings at the time of its intervention only and within the limits of Client's instructions, if any. The Company's sole responsibility is to its Client and this document does not exonerate parties to a transaction from exercising all their rights and obligations under the transaction documents. This document cannot be reproduced except in full, without prior written approval of the Company. Any unauthorized alteration, forgery or falsification of the content or appearance of this document is unlawful and offenders may be prosecuted to the fullest extent of the law. Unless otherwise stated the results shown in this test report refer only to the sample(s) tested and such sample(s) are retained for 30 days only.

Attention: To check the authenticity of testing /inspection report & certificate, please contact us at telephone: (86-755) 8307 1443, or email: [CN.Doccheck@sgs.com](mailto:CN.Doccheck@sgs.com)

### 6.6 Frequency Stability

Test Requirement: 47 CFR Part 27.54

Test Method: 47 CFR Part 2.1055  
KDB 935210 D05 clause 3.7  
ANSI C63.26-2015 clause 5.6

Limit: The frequency stability shall be sufficient to ensure that the fundamental emissions stay within the authorized bands of operation.

#### 6.6.1 E.U.T. Operation

Operating Environment:

Temperature: 25.2 °C Humidity: 60 % RH Atmospheric Pressure: 1020 mbar

EUT Operation: Drive the EUT to the maximum output power at maximum gain.

#### 6.6.2 Test Setup

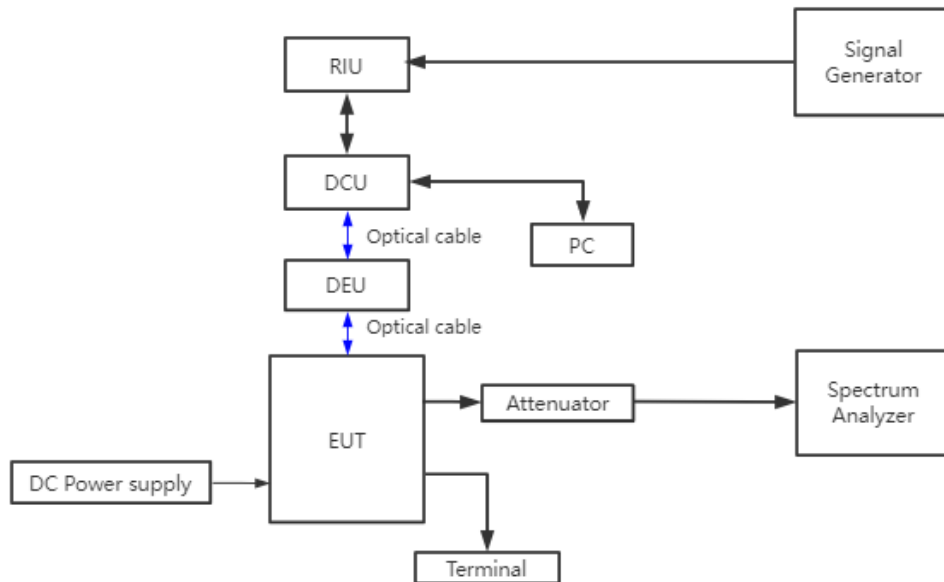

Unless otherwise agreed in writing, this document is issued by the Company subject to its General Conditions of Service printed overleaf, available on request or accessible at <http://www.sgs.com/en/Terms-and-Conditions.aspx> and, for electronic format documents, subject to Terms and Conditions for Electronic Documents at <http://www.sgs.com/en/Terms-and-Conditions/Terms-e-Documents.aspx>. Attention is drawn to the limitation of liability, indemnification and jurisdiction issues defined therein. Any holder of this document is advised that information contained hereon reflects the Company's findings at the time of its intervention only and within the limits of Client's instructions, if any. The Company's sole responsibility is to its Client and this document does not exonerate parties to a transaction from exercising all their rights and obligations under the transaction documents. This document cannot be reproduced except in full, without prior written approval of the Company. Any unauthorized alteration, forgery or falsification of the content or appearance of this document is unlawful and offenders may be prosecuted to the fullest extent of the law. Unless otherwise stated the results shown in this test report refer only to the sample(s) tested and such sample(s) are retained for 30 days only.

Attention: To check the authenticity of testing / inspection report & certificate, please contact us at telephone: (86-755) 8307 1443, or email: [CN.Doccheck@sgs.com](mailto:CN.Doccheck@sgs.com)

### 6.6.3 Test Procedure

Frequency stability measurement applies for an EUT that processes the input signal in a manner that could have an influence on its output signal frequency/frequencies. Measure frequency stability using the procedure in 5.6 with the following addition: Connect the reference clock input of the signal generator to the reference output of the frequency counter to affirm that any frequency offset is from the signal booster and not the difference in the reference oscillators of the measurement equipment.

Test procedure in 5.6:

Frequency stability is a measure of the frequency drift due to temperature and supply voltage variations, with reference to the frequency measured at +20 °C and rated supply voltage.

The operating carrier frequency shall be set up in accordance with the manufacturer's published operation and instruction manual prior to the commencement of these tests. No adjustment of any frequency determining circuit element shall be made subsequent to this initial set-up. Frequency stability is tested:

- a) At 10 °C intervals of temperatures between -30 °C and +50 °C at the manufacturer's rated supply voltage, and
- b) At +20 °C temperature and ±15% supply voltage variations. If a product is specified to operate over a range of input voltage then the -15% variation is applied to the lowermost voltage and the +15% is applied to the uppermost voltage.

During the test all necessary settings, adjustments and control of the EUT have to be performed without disturbing the test environment, i.e., without opening the environmental chamber. The frequency stabilities can be maintained to a lesser temperature range provided that the transmitter is automatically inhibited from operating outside the lesser temperature range. For handheld equipment that is only capable of operating from internal batteries and the supply voltage cannot be varied, the frequency stability tests shall be performed at the nominal battery voltage and the battery end point voltage specified by the manufacturer. An external supply voltage can be used and set at the internal battery nominal voltage, and again at the battery operating end point voltage which shall be specified by the equipment manufacturer.

If an unmodulated carrier is not available, the mean frequency of a modulated carrier can be obtained by using a frequency counter with gating time set to an appropriately large multiple of bit periods (gating time depending on the required accuracy). Full details on the choice of values shall be included in the test report.

### 6.6.4 Measurement Record

Please refer to Appendix - Test Data and Result for report GZCR220800101302.



Unless otherwise agreed in writing, this document is issued by the Company subject to its General Conditions of Service printed overleaf, available on request or accessible at <http://www.sgs.com/en/Terms-and-Conditions.aspx> and, for electronic format documents, subject to Terms and Conditions for Electronic Documents at <http://www.sgs.com/en/Terms-and-Conditions/Terms-e-Documents.aspx>. Attention is drawn to the limitation of liability, indemnification and jurisdiction issues defined therein. Any holder of this document is advised that information contained hereon reflects the Company's findings at the time of its intervention only and within the limits of Client's instructions, if any. The Company's sole responsibility is to its Client and this document does not exonerate parties to a transaction from exercising all their rights and obligations under the transaction documents. This document cannot be reproduced except in full, without prior written approval of the Company. Any unauthorized alteration, forgery or falsification of the content or appearance of this document is unlawful and offenders may be prosecuted to the fullest extent of the law. Unless otherwise stated the results shown in this test report refer only to the sample(s) tested and such sample(s) are retained for 30 days only.

Attention: To check the authenticity of testing /inspection report & certificate, please contact us at telephone: (86-755) 8307 1443, or email: [CN.Doccheck@sgs.com](mailto:CN.Doccheck@sgs.com)

### 6.7 Radiated Spurious emission

Test Requirement:	47 CFR Part 27.53(m)
Test Method:	KDB 935210 D05 clause 3.8 ANSI C63.26-2015 clause 5.6
Limit:	For digital base stations, the attenuation shall be not less than $43 + 10 \log (P)$ dB, unless a documented interference complaint is received from an adjacent channel licensee with an overlapping Geographic Service Area.

#### 6.7.1 E.U.T. Operation

Operating Environment:	
Temperature:	23.9 °C
Humidity:	56 % RH
Atmospheric Pressure:	1006 mbar
EUT Operation:	Drive the EUT to the maximum output power at maximum gain and MIMO function on.

#### 6.7.2 Test Setup

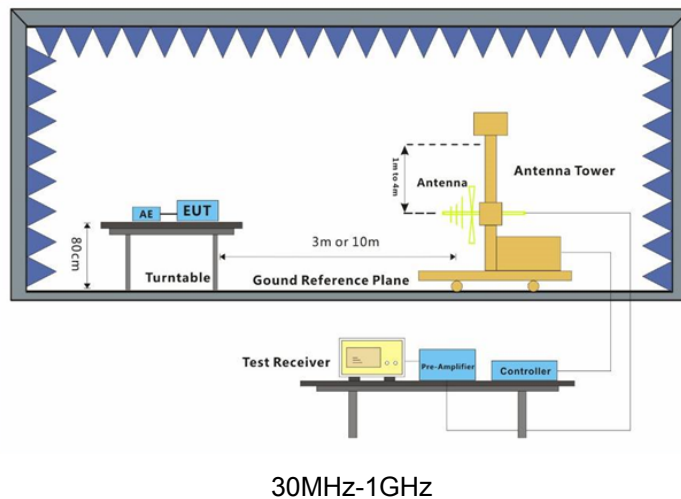



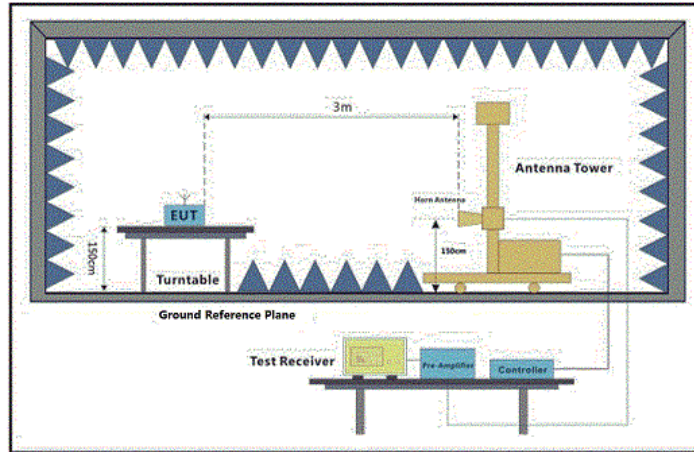

Above 1GHz



Unless otherwise agreed in writing, this document is issued by the Company subject to its General Conditions of Service printed overleaf, available on request or accessible at <http://www.sgs.com/en/Terms-and-Conditions.aspx> and, for electronic format documents, subject to Terms and Conditions for Electronic Documents at <http://www.sgs.com/en/Terms-and-Conditions/Terms-e-Documents.aspx>. Attention is drawn to the limitation of liability, indemnification and jurisdiction issues defined therein. Any holder of this document is advised that information contained hereon reflects the Company's findings at the time of its intervention only and within the limits of Client's instructions, if any. The Company's sole responsibility is to its Client and this document does not exonerate parties to a transaction from exercising all their rights and obligations under the transaction documents. This document cannot be reproduced except in full, without prior written approval of the Company. Any unauthorized alteration, forgery or falsification of the content or appearance of this document is unlawful and offenders may be prosecuted to the fullest extent of the law. Unless otherwise stated the results shown in this test report refer only to the sample(s) tested and such sample(s) are retained for 30 days only.

Attention: To check the authenticity of testing /inspection report & certificate, please contact us at telephone: (86-755) 8307 1443, or email: [CN.Doccheck@sgs.com](mailto:CN.Doccheck@sgs.com)

### 6.7.3 Test procedure

1. Scan from 30MHz to 40GHz, find the maximum radiation frequency to measure.
2. The technique used to find the Spurious Emissions of the transmitter was the antenna substitution method. Substitution method was performed to determine the actual ERP/EIRP emission levels of the EUT.

Below 1GHz test procedure as below:

- 1) The EUT was powered on and placed on a table in the chamber. The antenna of the transmitter was extended to its maximum length. modulation mode and the measuring receiver shall be tuned to the frequency of the transmitter under test.
- 2) Rotating through 360° the turntable. After the fundamental emission was maximized, a field strength measurement was made.
- 3) Steps 1) and 2) were performed with the EUT and the receive antenna in both vertical and horizontal polarization.
- 4) The transmitter was then removed and replaced with another antenna. The center of the antenna was approximately at the same location as the center of the transmitter.
- 5) A signal at the disturbance was fed to the substitution antenna by means of a non-radiating cable. With both the substitution and the receive antennas horizontally polarized, the receive antenna was raised and lowered to obtain a maximum reading at the test receiver. The level of the signal generator was adjusted until the measured field strength level in step 2) is obtained for this set of conditions.
- 6) The output power into the substitution antenna was then measured.
- 7) Steps 5) and 6) were repeated with both antennas vertically polarized.
- 8) Calculate power in dBm by the following formula:

Level (dBm) = Read Level (dBm) + Correction Factor (dB)

Above 1GHz test procedure as below:

- 1) Different between above is the test site, change from Semi- Anechoic Chamber to fully Anechoic Chamber.
- 2) Calculate power in dBm by the following formula:

Level (dBm) = Read Level (dBm) + Correction Factor (dB)

The test performed on bottom/middle/high channel, only the worst case middle channel was record in the report.

The product with lowest frequency higher than 30MHz, and with more than 20dB margin for the emission from 9KHz to 30MHz band during prescan, therefore, the emission data below 30MHz not record in the report

### 6.7.4 Measurement Record

Please refer to Appendix - Test Data and Result for report GZCR220800101302.



Unless otherwise agreed in writing, this document is issued by the Company subject to its General Conditions of Service printed overleaf, available on request or accessible at <http://www.sgs.com/en/Terms-and-Conditions.aspx> and, for electronic format documents, subject to Terms and Conditions for Electronic Documents at <http://www.sgs.com/en/Terms-and-Conditions/Terms-e-Documents.aspx>. Attention is drawn to the limitation of liability, indemnification and jurisdiction issues defined therein. Any holder of this document is advised that information contained hereon reflects the Company's findings at the time of its intervention only and within the limits of Client's instructions, if any. The Company's sole responsibility is to its Client and this document does not exonerate parties to a transaction from exercising all their rights and obligations under the transaction documents. This document cannot be reproduced except in full, without prior written approval of the Company. Any unauthorized alteration, forgery or falsification of the content or appearance of this document is unlawful and offenders may be prosecuted to the fullest extent of the law. Unless otherwise stated the results shown in this test report refer only to the sample(s) tested and such sample(s) are retained for 30 days only.

Attention: To check the authenticity of testing /inspection report & certificate, please contact us at telephone: (86-755) 8307 1443, or email: [CN.Doccheck@sgs.com](mailto:CN.Doccheck@sgs.com)

### 7 Test Setup Photographs

Refer to Appendix - Test Setup Photos for report GZCR2208001013AT.

### 8 EUT Constructional Details (EUT Photos)

Refer to External and Internal Photos for GZCR2208001013AT

- End of the Report -



Unless otherwise agreed in writing, this document is issued by the Company subject to its General Conditions of Service printed overleaf, available on request or accessible at <http://www.sgs.com/en/Terms-and-Conditions.aspx> and, for electronic format documents, subject to Terms and Conditions for Electronic Documents at <http://www.sgs.com/en/Terms-and-Conditions/Terms-e-Documents.aspx>. Attention is drawn to the limitation of liability, indemnification and jurisdiction issues defined therein. Any holder of this document is advised that information contained hereon reflects the Company's findings at the time of its intervention only and within the limits of Client's instructions, if any. The Company's sole responsibility is to its Client and this document does not exonerate parties to a transaction from exercising all their rights and obligations under the transaction documents. This document cannot be reproduced except in full, without prior written approval of the Company. Any unauthorized alteration, forgery or falsification of the content or appearance of this document is unlawful and offenders may be prosecuted to the fullest extent of the law. Unless otherwise stated the results shown in this test report refer only to the sample(s) tested and such sample(s) are retained for 30 days only.

Attention: To check the authenticity of testing /inspection report & certificate, please contact us at telephone: (86-755) 8307 1443, or email: [CN.Doccheck@sgs.com](mailto:CN.Doccheck@sgs.com)