



**DATE: 13 November 2016**

**I.T.L. (PRODUCT TESTING) LTD.**  
**FCC Radio Test Report**  
for  
**Corning Optical Communication**  
**Wireless**

**Equipment under test:**

**ONE Distributed Antenna System**

**Remote Extender Unit RXU 2325**

**(TDD Section 2496-2690MHz Band)**

Tested by:

  
M. Zohar

Approved by:

  
D. Shidlowsky

This report must not be reproduced, except in full, without the written permission of I.T.L. (Product Testing) Ltd.  
This report relates only to items tested.



# Measurement/Technical Report for Corning Optical Communication Wireless ONE Distributed Antenna System

## FCC ID: OJF1RXUN

This report concerns: Original Grant: X  
Class II change:  
Class I change:

Equipment type: B21 – Part 20 Industrial Booster (CMRS)

Limits used: 47CFR Parts 2, 27

Measurement procedure used is KDB 971168 D03 v01 and  
KDB 935210 D05 v01r01

Substitution Method used as in ANSI/TIA-603-D: 2010

Application for Certification  
prepared by:  
R. Pinchuck  
ITL (Product Testing) Ltd.  
1 Bat Sheva St.  
Lod 7120101  
Israel  
e-mail rpinchuck@itl.co.il

Applicant for this device:  
(different from "prepared by")  
Habib Riazi  
Corning Optical Communication Wireless  
13221 Woodland Park Rd., Suite #400  
Herndon, VA. 20171  
U.S.A.  
Tel: +1-541-758-2880  
Fax: +1-703-848-0260  
e-mail: RiaziH@corning.com



# TABLE OF CONTENTS

<b>1.</b>	<b>GENERAL INFORMATION</b>	<b>5</b>
1.1	Administrative Information	5
1.2	List of Accreditations	6
1.3	Product Description	7
1.4	Test Methodology	7
1.5	Test Facility	7
1.6	Measurement Uncertainty	7
<b>2.</b>	<b>SYSTEM TEST CONFIGURATION</b>	<b>8</b>
2.1	Justification	8
2.2	EUT Exercise Software	8
2.3	Special Accessories	8
2.4	Equipment Modifications	8
2.5	Configuration of Tested System	9
<b>3.</b>	<b>TEST SET-UP PHOTOS</b>	<b>11</b>
<b>4.</b>	<b>PEAK OUTPUT POWER</b>	<b>15</b>
4.1	Test Specification	15
4.2	Test Procedure	15
4.3	Test Limit	15
4.4	Test Results	15
4.5	Test Equipment Used; Peak Output Power	21
<b>5.</b>	<b>PEAK TO AVERAGE POWER RATIO</b>	<b>22</b>
5.1	Test Specification	22
5.2	Test Procedure	22
5.3	Test Limit	22
5.4	Test Results	22
5.5	Test Equipment Used; 0.1% PAPR	27
<b>6.</b>	<b>OCCUPIED BANDWIDTH</b>	<b>28</b>
6.1	Test Specification	28
6.2	Test Procedure	28
6.3	Test Limit	28
6.4	Test Results	28
6.5	Test Equipment Used; Occupied Bandwidth	38
<b>7.</b>	<b>SPURIOUS EMISSIONS AT ANTENNA TERMINALS</b>	<b>39</b>
7.1	Test Specification	39
7.2	Test Procedure	39
7.3	Test Limit	39
7.4	Test Results	39
7.5	Test Equipment Used; Out of Band Emission at Antenna Terminals	43
<b>8.</b>	<b>BAND EDGE SPECTRUM</b>	<b>44</b>
8.1	Test Specification	44
8.2	Test Procedure	44
8.3	Test Limit	44
8.4	Test Results	44
8.5	Test Equipment Used; Band Edge Spectrum	48
<b>9.</b>	<b>SPURIOUS EMISSIONS (RADIATED)</b>	<b>49</b>
9.1	Test Specification	49
9.2	Test Procedure	49
9.3	Test Limit	50
9.4	Test Results	50
9.5	Test Instrumentation Used, Radiated Measurements	51



<b>10.</b>	<b>INTERMODULATION CONDUCTED</b> -----	<b>52</b>
10.1	Test Procedure .....	52
10.2	Test Limit .....	52
10.3	Test Results.....	52
10.4	Test Equipment Used; Intermodulation Conducted .....	53
<b>11.</b>	<b>INTERMODULATION RADIATED</b> -----	<b>54</b>
11.1	Test Procedure .....	54
11.2	Test Limit .....	55
11.3	Test Results.....	55
11.4	Test Instrumentation Used; Radiated Measurements Intermodulation.....	56
<b>12.</b>	<b>OUT-OF-BAND REJECTION (TDD)</b> -----	<b>57</b>
12.1	Test Specification .....	57
12.2	Test Procedure .....	57
12.3	Test Limit .....	57
12.4	Test Results.....	57
12.5	Test Equipment Used; Out-of-Band Rejection .....	58
<b>13.</b>	<b>APPENDIX A - CORRECTION FACTORS</b> -----	<b>59</b>
13.1	Correction factors for RF OATS Cable 35m.....	59
13.2	Correction factors for RF OATS Cable 10m.....	60
13.3	Correction factors for Horn Antenna .....	61
13.4	Correction factors for Horn ANTENNA.....	62
13.5	Correction factors for Log Periodic Antenna .....	63
13.6	Correction factors for Biconical Antenna .....	64
13.7	Correction factors for ACTIVE LOOP ANTENNA .....	65



# 1. General Information

## 1.1 Administrative Information

Manufacturer:	Corning Optical Communication Wireless
Manufacturer's Address:	13221 Woodland Park Rd., Suite #400 Herndon, VA. 20171 U.S.A. Tel: +1-541-758-2880 Fax: +1-703-848-0260
Manufacturer's Representative:	Habib Riazi
Equipment Under Test (E.U.T):	ONE Distributed Antenna System
Equipment Model No.:	Remote Extender Unit RXU 2325
Equipment Serial No.:	1016070009
Date of Receipt of E.U.T:	July 03, 2016
Start of Test:	July 11, 2016
End of Test:	September 9, 2016
Test Laboratory Location:	I.T.L (Product Testing) Ltd. 1 Batsheva St, Lod, Israel 7116002
Test Specifications:	FCC Parts 2, 27



## **1.2 List of Accreditations**

The EMC laboratory of I.T.L. is accredited by/registered with the following bodies:

1. The American Association for Laboratory Accreditation (A2LA) (U.S.A.), Certificate No. 1152.01.
2. The Federal Communications Commission (FCC) (U.S.A.), FCC Designation Number IL1005.
3. The Israel Ministry of the Environment (Israel), Registration No. 1104/01.
4. The Voluntary Control Council for Interference by Information Technology Equipment (VCCI) (Japan), Registration Numbers: C-3006, R-2729, T-1877, G-245.
5. Industry Canada (Canada), IC File No.: 46405-4025; Site No. IC 4025A-1, IC 4025A-2.

I.T.L. Product Testing Ltd. is accredited by the American Association for Laboratory Accreditation (A2LA) and the results shown in this test report have been determined in accordance with I.T.L.'s terms of accreditation unless stated otherwise in the report.



### **1.3 Product Description**

The RxU2325 is an add-on module which plugs into the RAU (either RAU5x, RAU5 or RAU4) and enables support for two additional bands: 2.3 GHz WCS and 2.5 GHz LTE (TDD).

### **1.4 Test Methodology**

Both conducted and radiated testing were performed according to the procedures in KDB 971168 D03 v01 and KDB 935210 D05 v01r01. Radiated testing was performed at an antenna to EUT distance of 3 meters.

### **1.5 Test Facility**

Both conducted and radiated emissions tests were performed at I.T.L.'s testing facility in Lod, Israel. I.T.L.'s EMC Laboratory is accredited by A2LA, certificate No. 1152.01 and its FCC Designation Number is IL1005.

### **1.6 Measurement Uncertainty**

Conducted Emission (CISPR 11, EN 55011, CISPR 22, EN 55022, ANSI C63.4)

0.15 – 30 MHz:

Expanded Uncertainty (95% Confidence, K=2):

± 3.44 dB

Radiated Emission (CISPR 11, EN 55011, CISPR 22, EN 55022, ANSI C63.4)  
for open site 30-1000MHz:

Expanded Uncertainty (95% Confidence, K=2):

± 4.98 dB



## 2. System Test Configuration

### 2.1 *Justification*

The test setup was configured to closely resemble the standard installation. The EUT consists of the RXU2325 installed in RAU5X. All source signals are represented in the setup by appropriate signal generators. An “Exercise” SW on the computer was used to enable / disable transmission of the RXU2325, while the EUT output was connected to the spectrum analyzer. All channels transmitted during the testing. There is neither an intermediate amplified nor donor antenna in the uplink. All components included in the UL path are connected by cables.

### 2.2 *EUT Exercise Software*

HCM SW Version: 2.2 B21  
Embedded SW Version for RXU2325: rxut\_ab64\_22\_12

### 2.3 *Special Accessories*

No special accessories were needed in order to achieve compliance.

### 2.4 *Equipment Modifications*

No modifications were needed in order to achieve compliance.



## 2.5 Configuration of Tested System

Product Name	ONE Distributed Antenna System
Model Name	RXU 2325
Working voltage	48.0VDC
Mode of operation	Industrial Booster for TDD 2.5G band
Modulations	64QAM, 16QAM, QPSK
Assigned Frequency Range	2496.0MHz-2690.0MHz
Operation Frequency Range	2496.0MHz-2690.0MHz
Transmit power	~20.0dBm
Antenna Gain	12.5 dBi
DATA rate	N/A
Modulation BW	10.0MHz

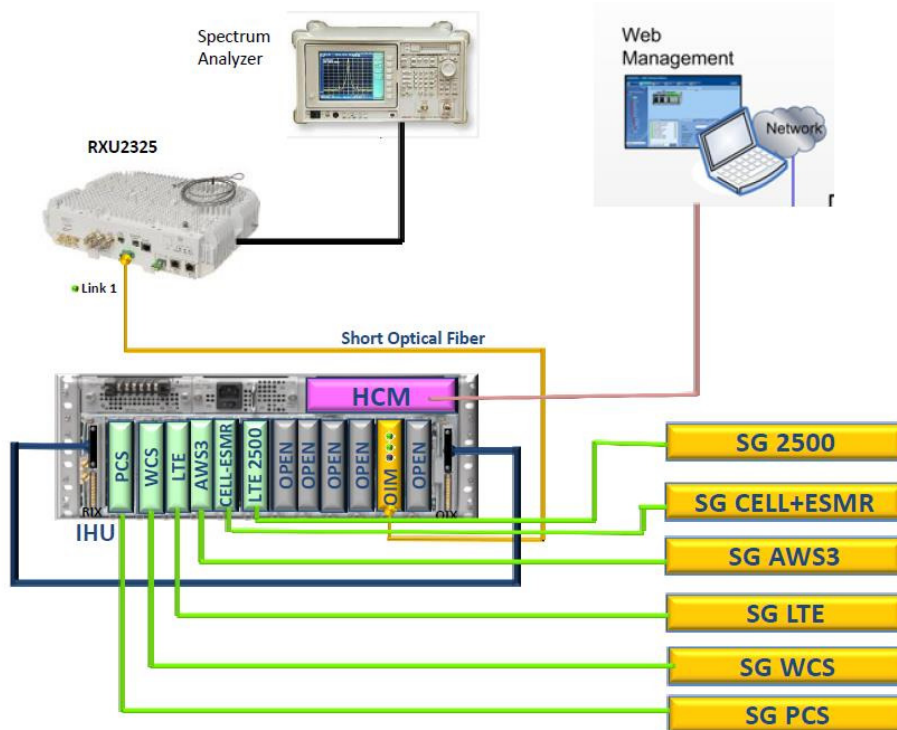


Figure 1. Test Set-Up – Conducted

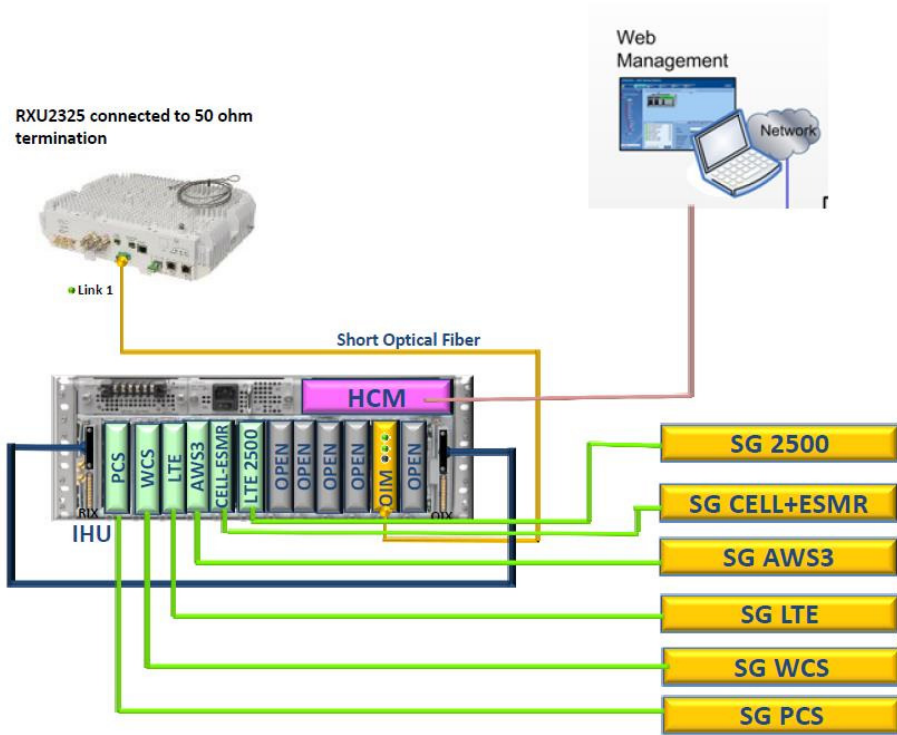


Figure 2. Test Set-Up - Radiated

### 3. Test Set-up Photos

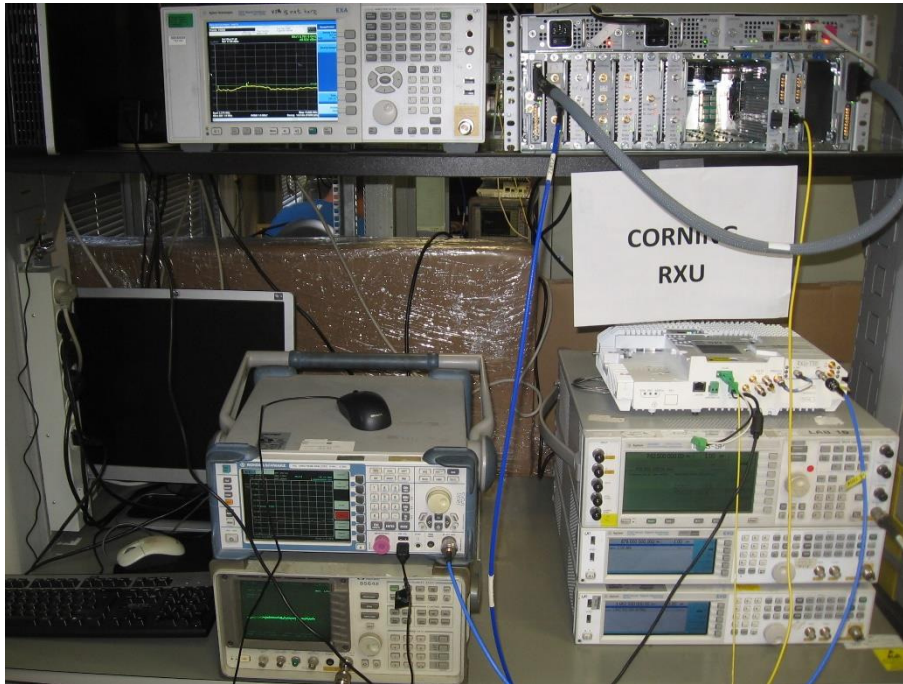


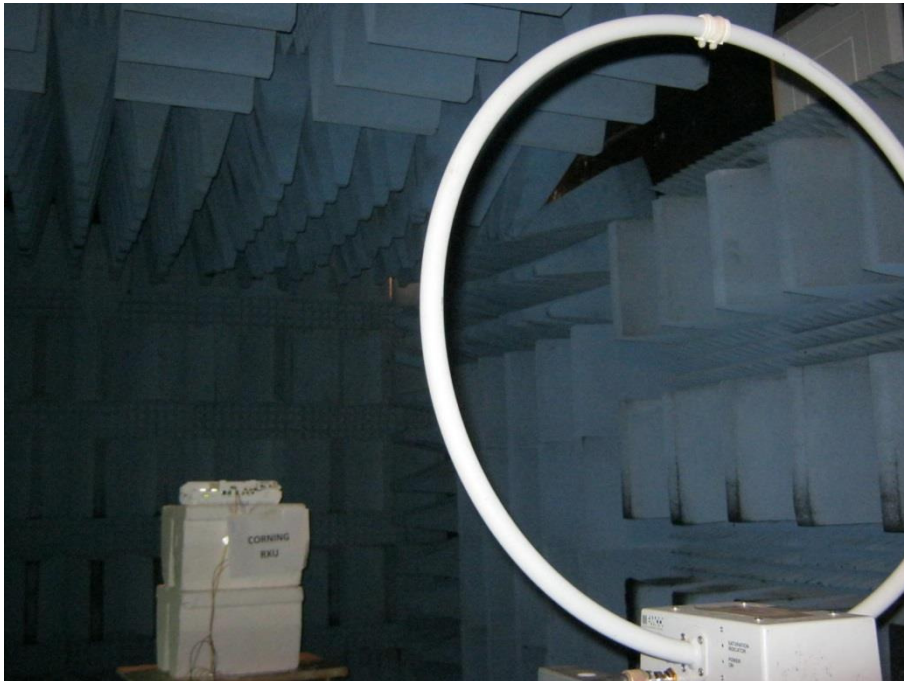
Figure 3. Conducted Emission From Antenna Port Tests



Figure 4. Radiated Emission Test



**Figure 5. Radiated Emission Test**



**Figure 6. Radiated Emission Test**

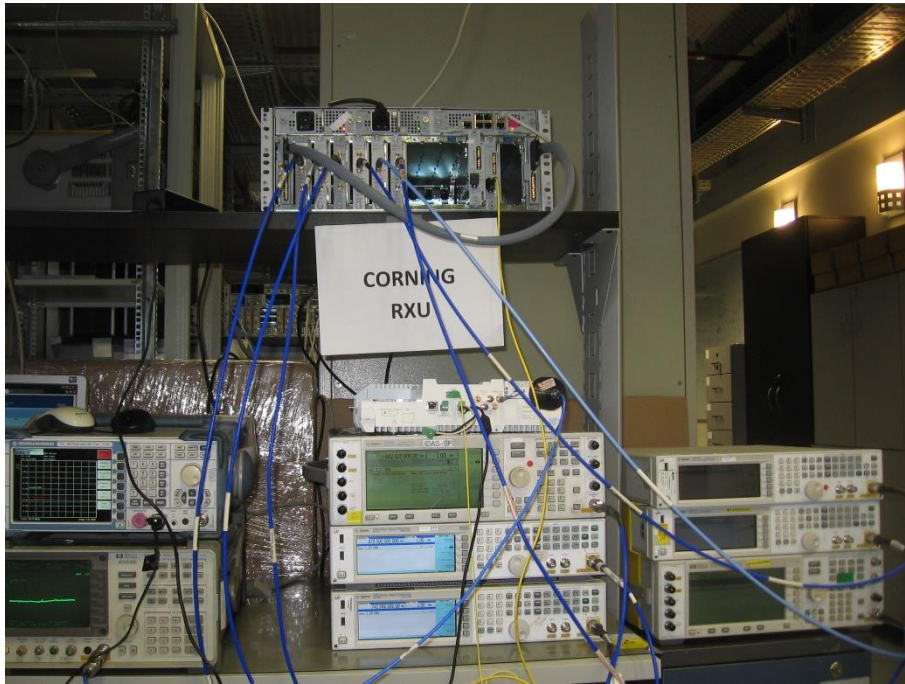




**Figure 7. Radiated Emission Test**



**Figure 8. Radiated Emission Test**



**Figure 9. Intermodulation Conducted Emission Test**

## 4. Peak Output Power

### 4.1 Test Specification

FCC Part 27, Subpart C, Section: 27.50(h)(1)(i)

### 4.2 Test Procedure

(Temperature (22°C)/ Humidity (35%RH))

The E.U.T. antenna terminal was connected to the Spectrum Analyzer through an external attenuator and an appropriate coaxial cable (loss=31.0dB). The E.U.T. RF output was modulated with QPSK, 16QAM and 64QAM, at 10.0 MHz BW. Special attention was taken to prevent Spectrum Analyzer RF input overload.

### 4.3 Test Limit

The maximum EIRP of a main, booster or base station shall not exceed 33 dBW + 10log(X/Y) dBW, where X is the actual channel width in MHz and Y is either 6 MHz if prior to transition or the station is in the MBS following transition or 5.5 MHz if the station is in the LBS and UBS following transition. The limit is calculated to be:  $63 + 10 \log (10 \text{ MHz}/12 \text{ MHz}) = 62.2 \text{ dBm}$ .

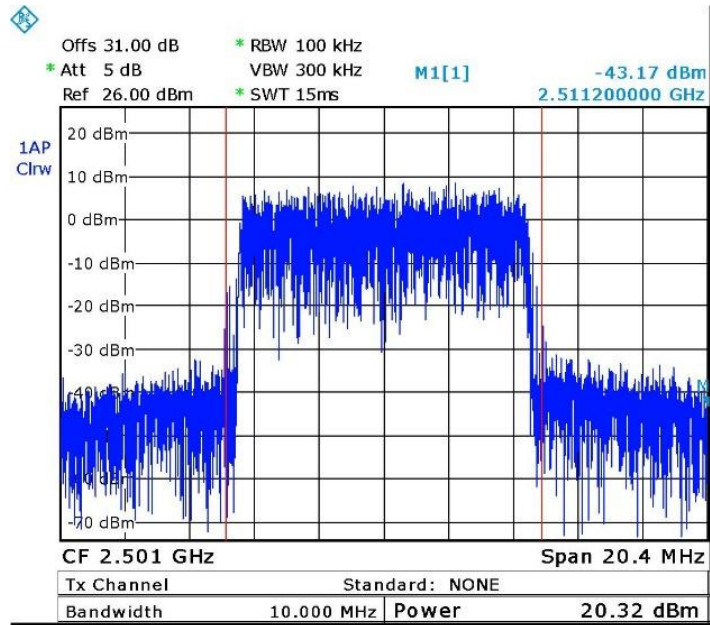
### 4.4 Test Results

Modulation	Operation Frequency	Reading	Antenna Gain	EIRP	Limit	Margin
	(MHz)	(dBm)	(dBi)	(dBm)	(dBm)	(dB)
64QAM	2501.0	20.3	12.5	32.8	62.2	-29.4
	2593.0	20.8	12.5	33.3	62.2	-28.9
	2685.0	20.4	12.5	32.9	62.2	-29.3
16QAM	2501.0	20.1	12.5	32.6	62.2	-29.6
	2593.0	20.8	12.5	33.3	62.2	-28.9
	2685.0	20.2	12.5	32.7	62.2	-29.5
QPSK	2501.0	20.4	12.5	32.9	62.2	-29.3
	2593.0	20.9	12.5	33.4	62.2	-28.8
	2685.0	20.3	12.5	32.8	62.2	-29.4

Figure 10 Peak Output Power

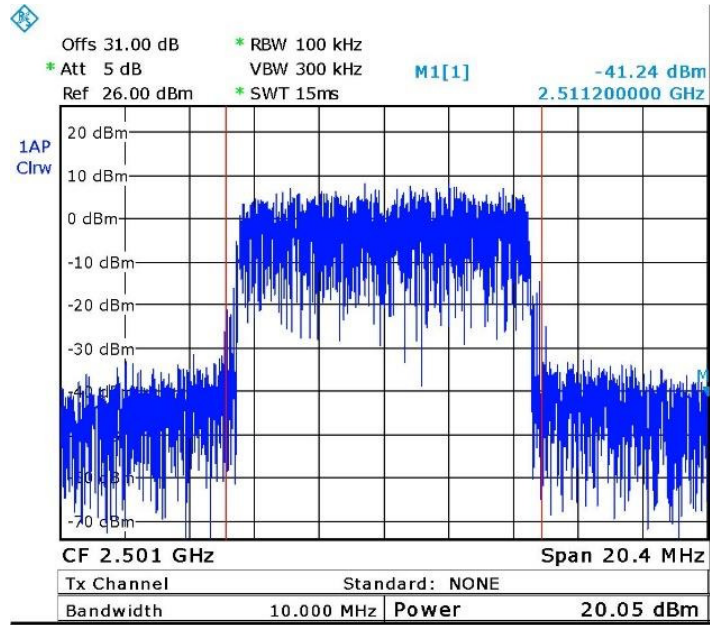
JUDGEMENT: Passed by 28.8 dB

See additional information in *Figure 11 to Figure 19*.



Date: 12.JUL.2016 09:37:07

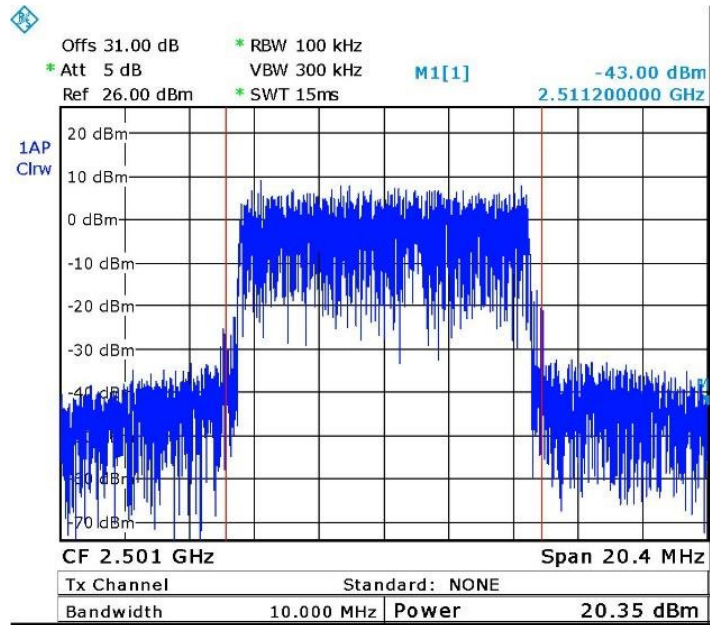
Figure 11. — 2501.0 MHz -64QAM



Date: 12.JUL.2016 09:35:38

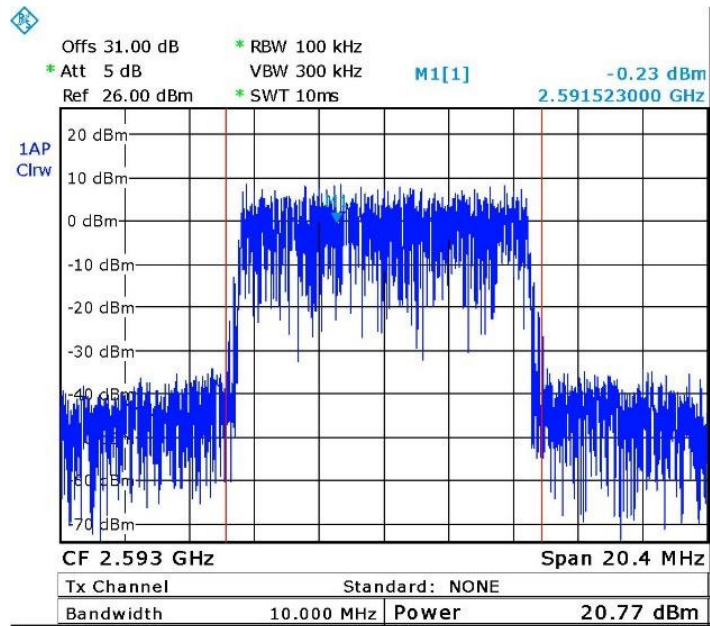
Figure 12. — 2501.0 MHz -16QAM





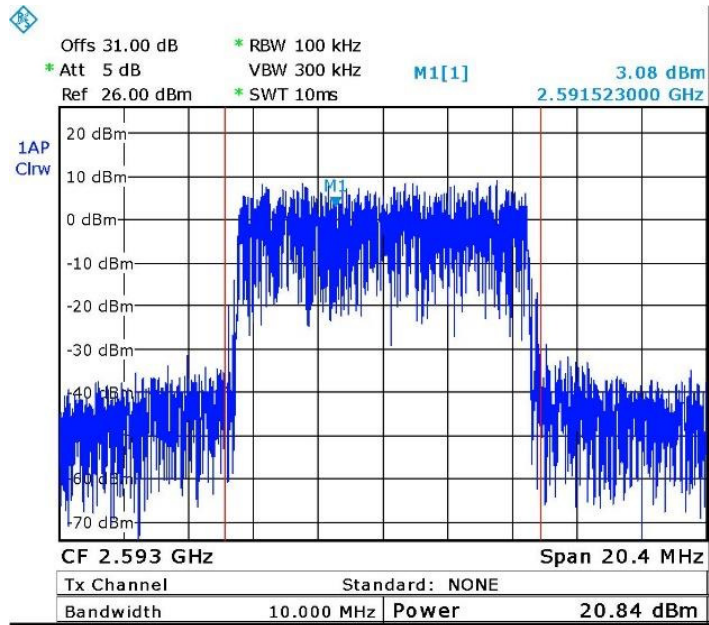
Date: 12.JUL.2016 09:35:13

Figure 13. — 2501.0 MHz- QPSK



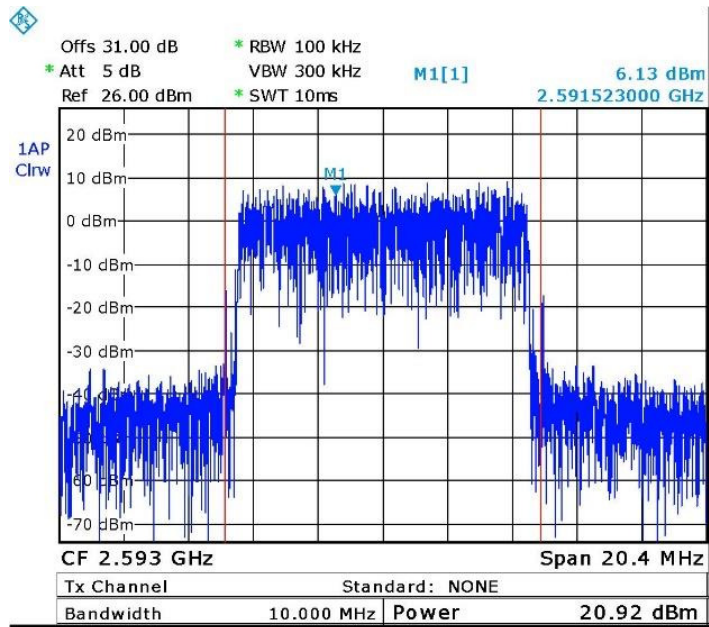
Date: 12.JUL.2016 09:29:02

Figure 14. — 2593.0 MHz -64QAM



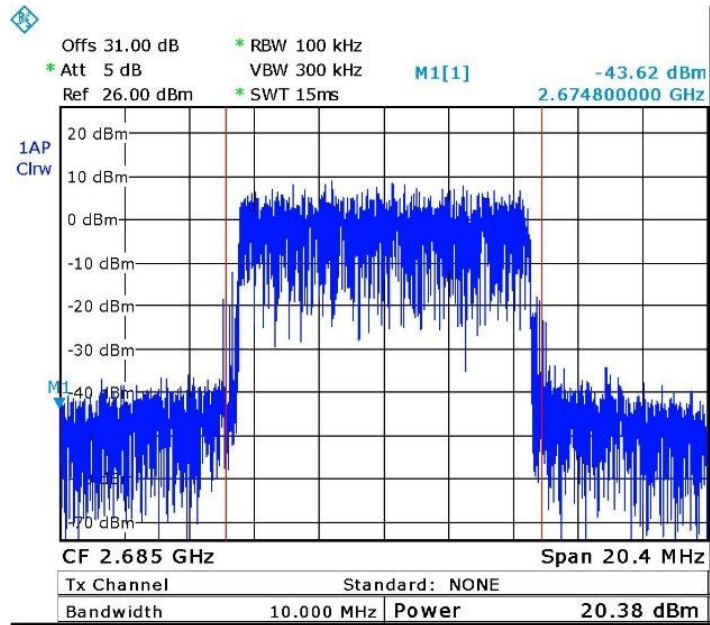
Date: 12.JUL.2016 09:28:31

Figure 15. — 2593.0 MHz – 16QAM



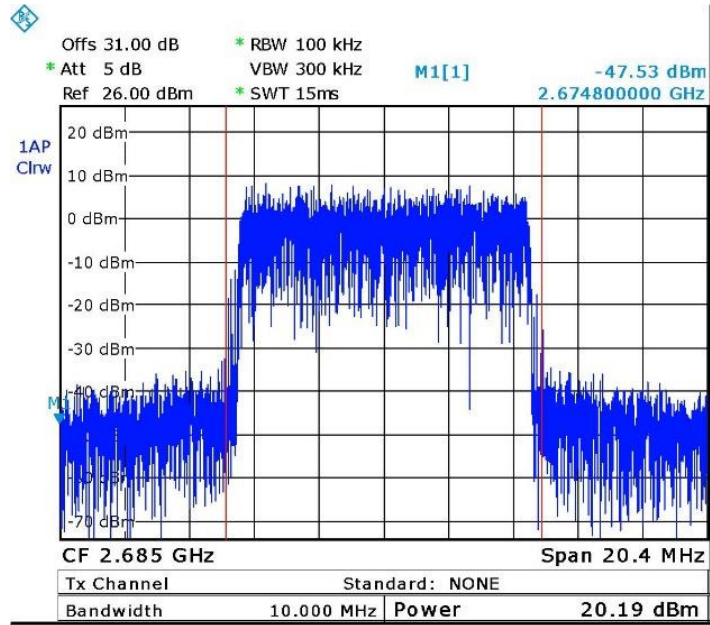
Date: 12.JUL.2016 09:28:49

Figure 16. — 2593.0 MHz- QPSK



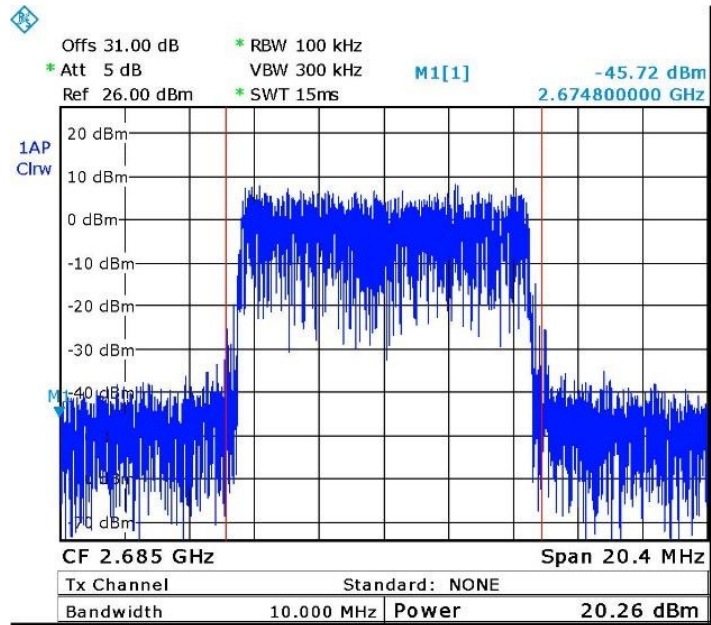
Date: 12.JUL.2016 09:38:09

Figure 17. — 2685.0 MHz -64QAM



Date: 12.JUL.2016 09:39:29

Figure 18. — 2685.0 MHz -16QAM



Date: 12.JUL.2016 09:39:06

Figure 19. — 2685.0 MHz- QPSK



#### 4.5 Test Equipment Used; Peak Output Power

Instrument	Manufacturer	Model	Serial Number	Calibration	
				Last Calibration Date	Next Calibration Date
Spectrum Analyzer	R&S	FSL6	100194	February 29, 2016	March 1, 2017
Vector Signal Generator	Agilent	N5172B	MY51350584	July 1, 2016	July 1, 2017
30 dB Attenuator	MCL	BW-S30W5	533	July 5, 2016	July 5, 2017

Figure 20 Test Equipment Used

## 5. Peak to Average Power Ratio

### 5.1 Test Specification

FCC Part 27, Subpart C, Section: 27.50(h)(1)(i)

### 5.2 Test Procedure

(Temperature (22°C)/ Humidity (35%RH))

Measurements were using CCDF function for each modulation.

### 5.3 Test Limit

In measuring transitions in this band using an average power technique, the PAPR of the transitions may not exceed 13dB.

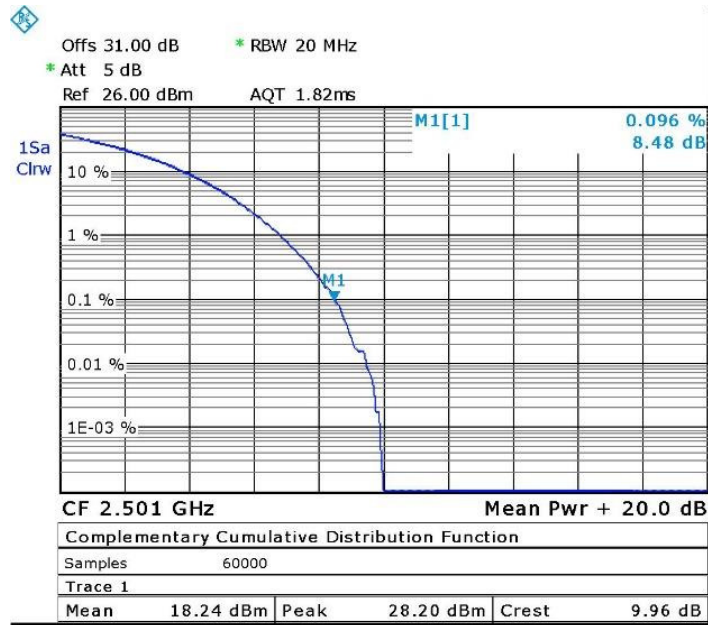
### 5.4 Test Results

Modulation	Operation Frequency	0.1% PAPR	Limit	Margin
	(MHz)	(dB)	(dB)	(dB)
64QAM	2501.0	8.5	13.0	-4.5
	2593.0	8.6	13.0	-4.4
	2685.0	8.2	13.0	-4.8
16QAM	2501.0	8.5	13.0	-4.5
	2593.0	8.4	13.0	-4.6
	2685.0	8.2	13.0	-4.8
QPSK	2501.0	8.5	13.0	-4.5
	2593.0	8.6	13.0	-4.4
	2685.0	8.4	13.0	-4.6

**Figure 21 Test Results Peak to Average Power Ratio**

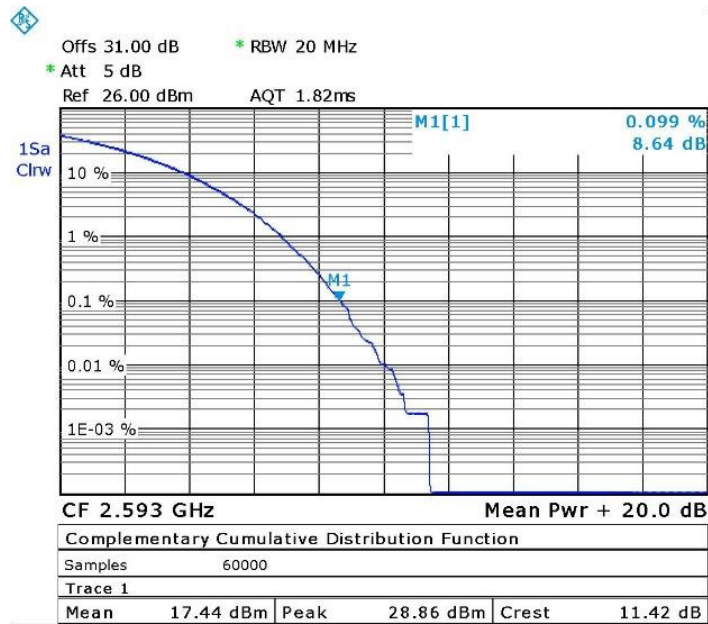
JUDGEMENT: Passed

For additional information see *Figure 22 to Figure 30*.



Date: 12.JUL.2016 10:06:58

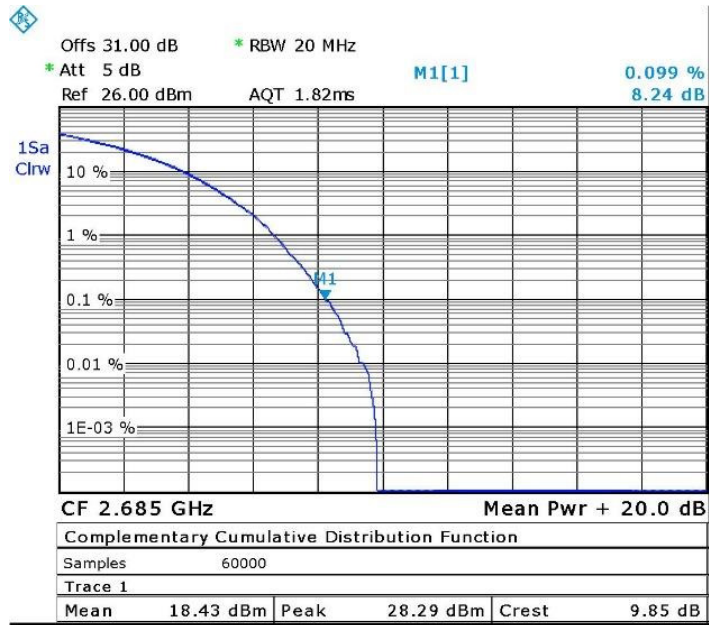
Figure 22. —64QAM, 2501.0 MHz



Date: 12.JUL.2016 10:03:23

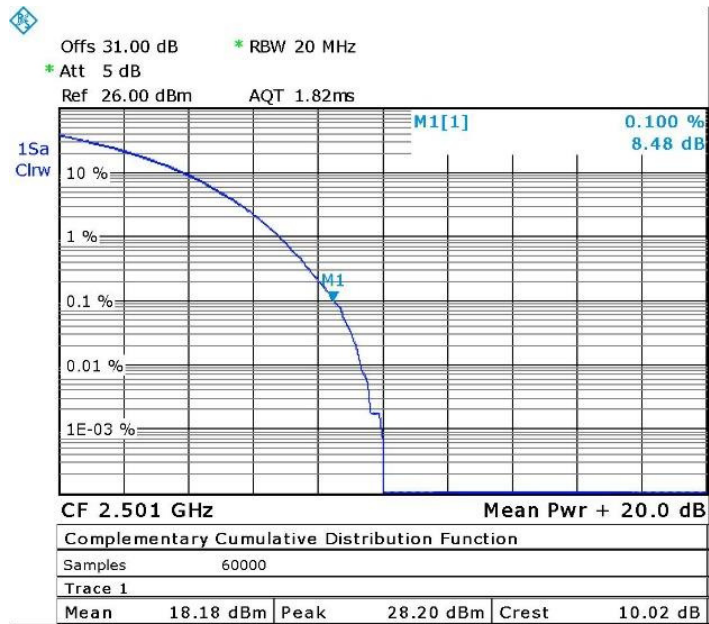
Figure 23. — 64QAM, 2593.0 MHz





Date: 12.JUL.2016 10:00:24

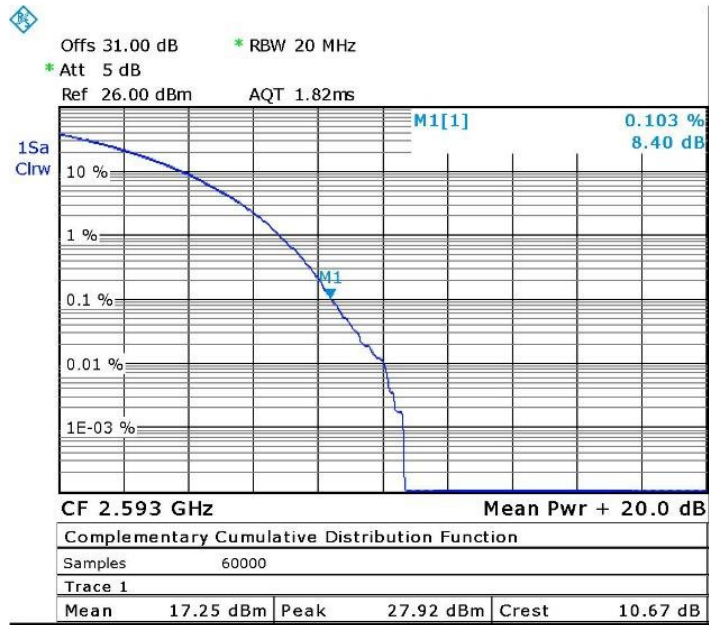
Figure 24. — 64QAM, 2685.0 MHz



Date: 12.JUL.2016 10:05:30

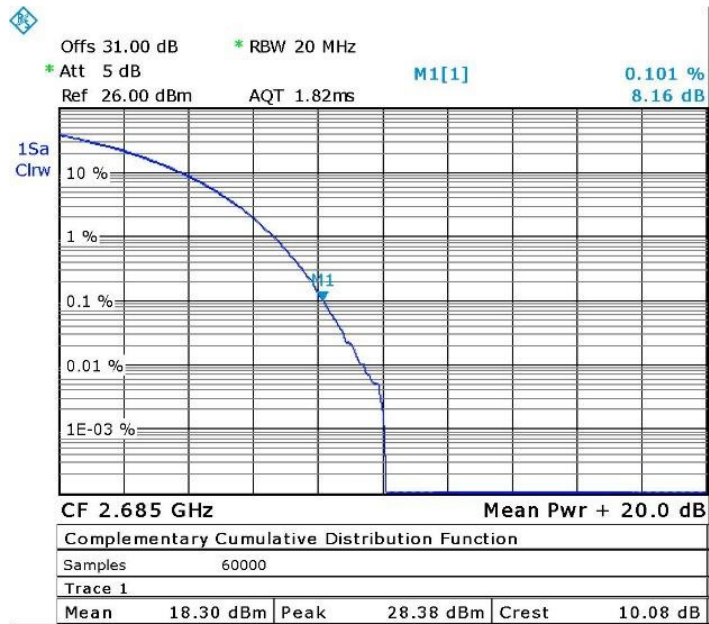
Figure 25. — 16QAM, 2501.0 MHz





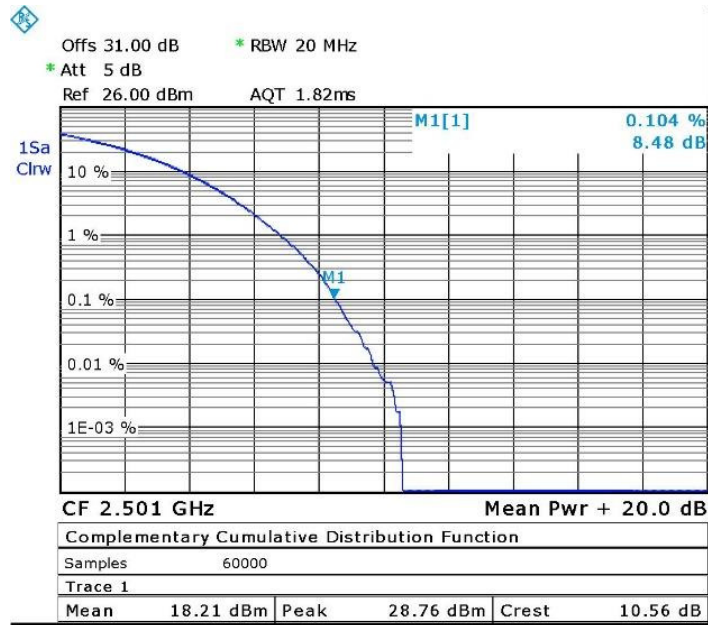
Date: 12.JUL.2016 10:04:44

Figure 26. — 16QAM, 2593.0 MHz



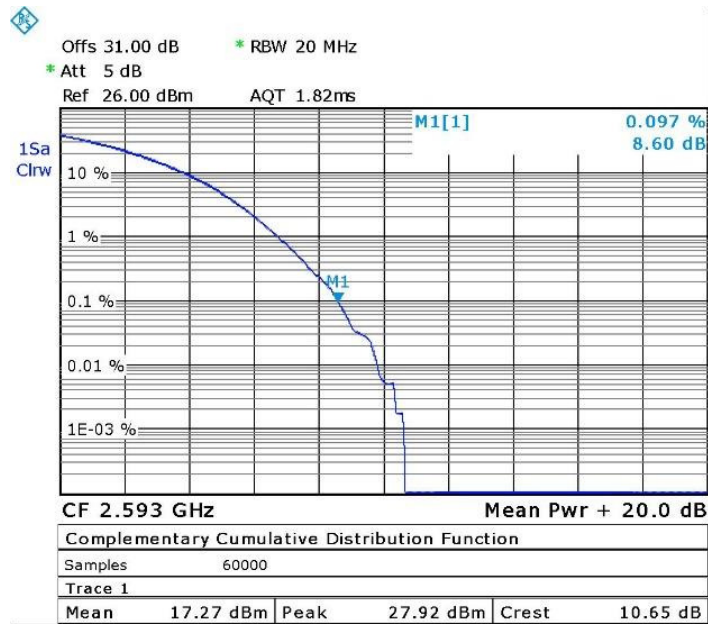
Date: 12.JUL.2016 09:57:42

Figure 27. — 16QAM, 2685.0 MHz



Date: 12.JUL.2016 10:05:51

Figure 28. —QPSK, 2501.0 MHz



Date: 12.JUL.2016 10:04:22

Figure 29. — QPSK, 2593.0 MHz

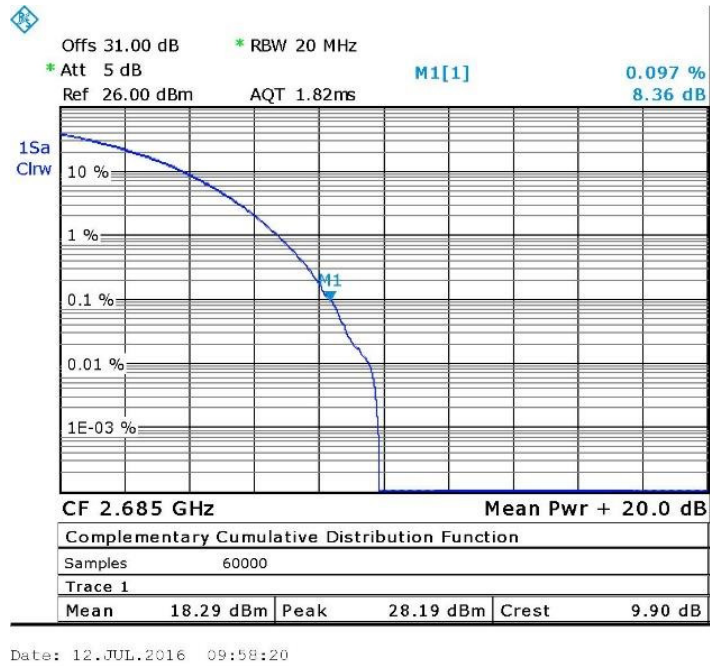


Figure 30. — QPSK, 2685.0 MHz

### 5.5 Test Equipment Used; 0.1% PAPR

Instrument	Manufacturer	Model	Serial Number	Calibration	
				Last Calibration Date	Next Calibration Date
Spectrum Analyzer	R&S	FSL6	100194	February 29, 2016	March 1, 2017
Vector Signal Generator	Agilent	N5172B	MY51350584	July 1, 2016	July 1, 2017
30 dB Attenuator	MCL	BW-S30W5	533	July 5, 2016	July 5, 2017

Figure 31 Test Equipment Used

## 6. Occupied Bandwidth

### 6.1 Test Specification

FCC Part 2, Section 1049

### 6.2 Test Procedure

(Temperature (22°C)/ Humidity (35%RH))

The E.U.T. was set to the applicable test frequency with modulation. The E.U.T. antenna terminal was connected to the spectrum analyzer through an external attenuator and an appropriate coaxial cable. The OBW function (99%) was using for these evaluation.

Occupied bandwidth measured was repeated for each modulation.

### 6.3 Test Limit

N/A

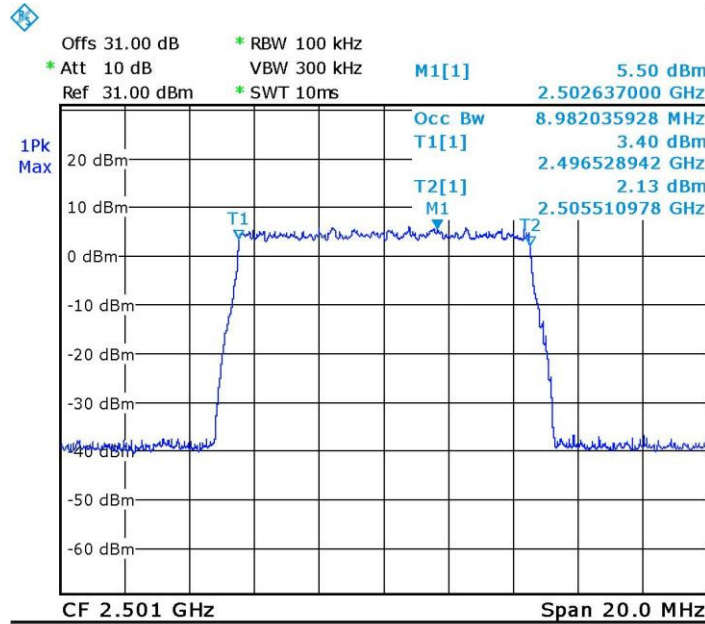
### 6.4 Test Results

Modulation	Port	Operating Frequency	Reading
	(Input/ Output)	(MHz)	(MHz)
64QAM	Input	2501.0	8.9
	Output	2501.0	8.9
	Input	2593.0	8.9
	Output	2593.0	8.9
	Input	2685.0	9.0
	Output	2685.0	9.0
16QAM	Input	2501.0	8.9
	Output	2501.0	8.9
	Input	2593.0	8.9
	Output	2593.0	8.9
	Input	2685.0	8.9
	Output	2685.0	8.9
QPSK	Input	2501.0	8.9
	Output	2501.0	8.9
	Input	2593.0	8.9
	Output	2593.0	8.9
	Input	2685.0	8.9
	Output	2685.0	8.9

Figure 32 Occupied Bandwidth Test Results

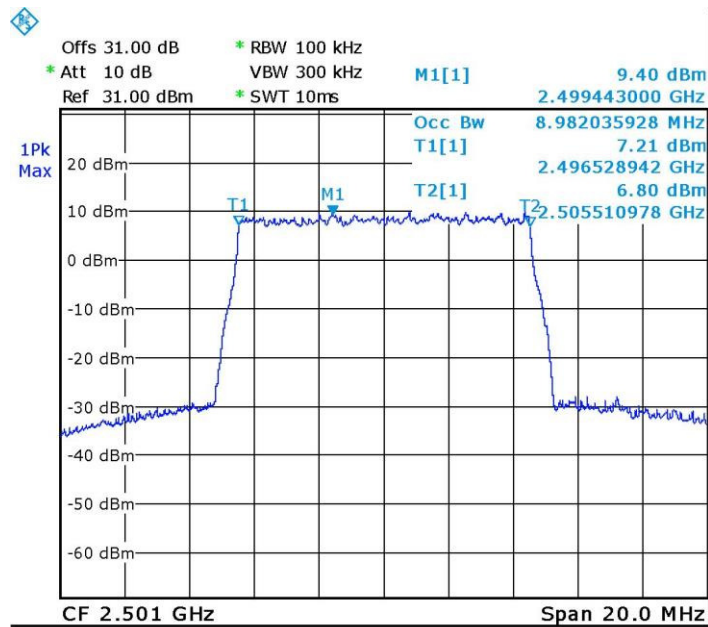
JUDGEMENT: Passed

See additional information in *Figure 33* to *Figure 50*.



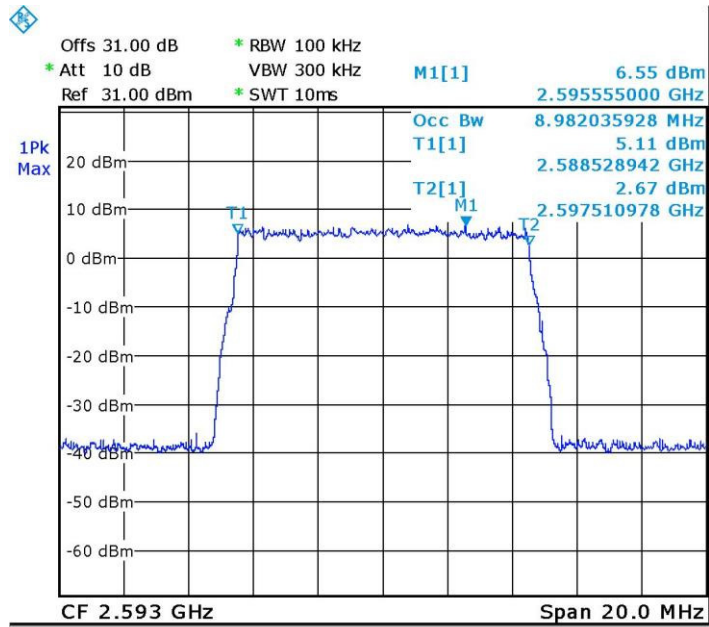
Date: 12.JUL.2016 10:49:10

Figure 33 Occupied Bandwidth INPUT, 2501.0MHz, 64QAM



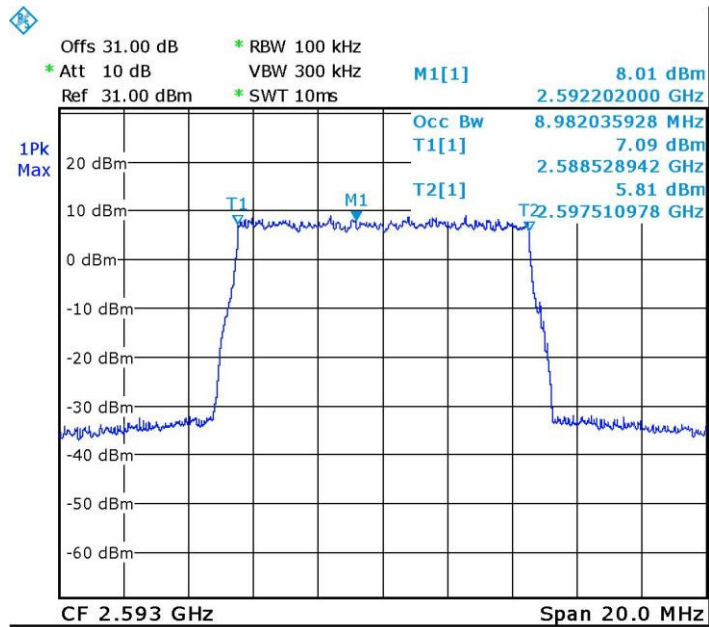
Date: 12.JUL.2016 10:29:39

Figure 34 Occupied Bandwidth OUTPUT, 2501.0MHz, 64QAM



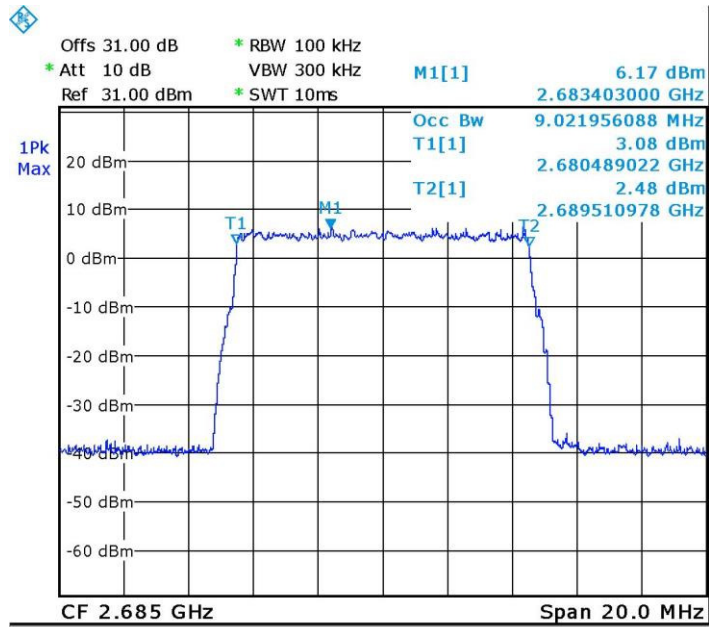
Date: 12.JUL.2016 10:44:18

Figure 35 Occupied Bandwidth INPUT, 2593.0MHz, 64QAM



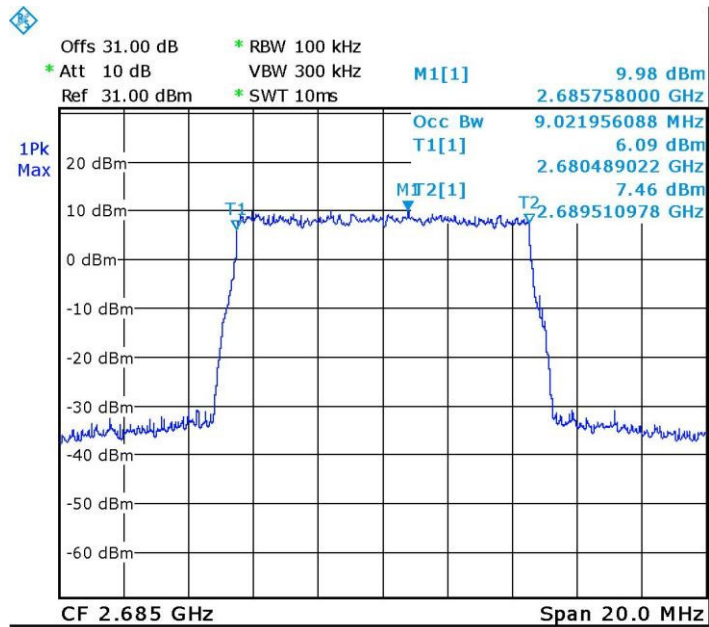
Date: 12.JUL.2016 10:35:09

Figure 36 Occupied Bandwidth OUTPUT, 2593.0MHz, 64QAM



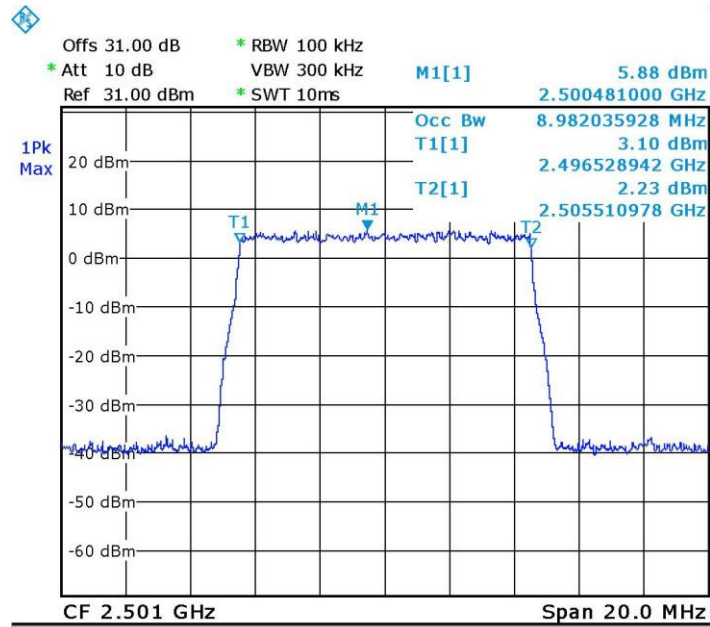
Date: 12.JUL.2016 10:43:23

Figure 37 Occupied Bandwidth INPUT, 2685.0MHz, 64QAM



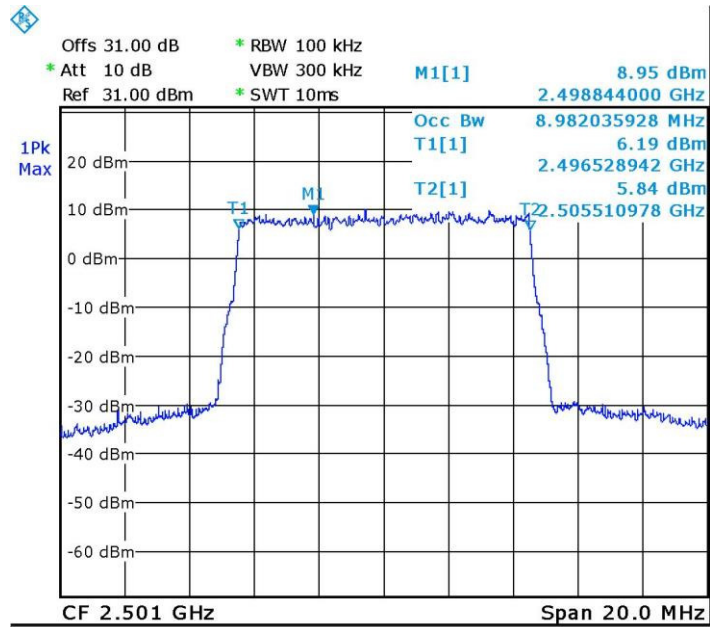
Date: 12.JUL.2016 10:36:27

Figure 38 Occupied Bandwidth OUTPUT, 2685.0MHz, 64QAM



Date: 12.JUL.2016 10:47:24

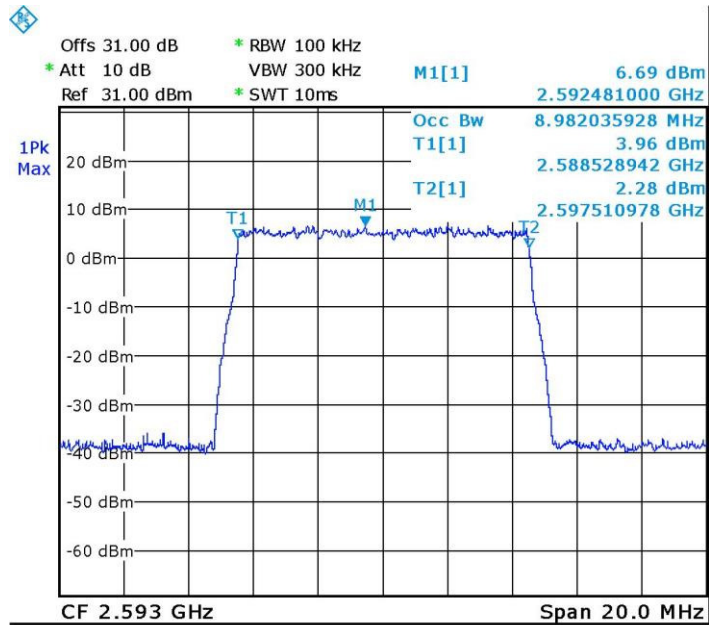
Figure 39 Occupied Bandwidth INPUT, 2501.0MHz, 16QAM



Date: 12.JUL.2016 10:31:26

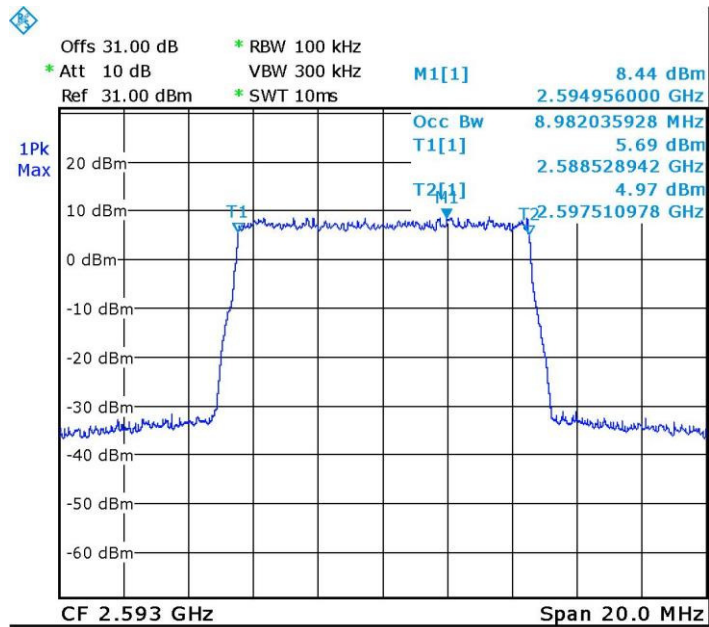
Figure 40 Occupied Bandwidth OUTPUT, 2501.0MHz, 16QAM





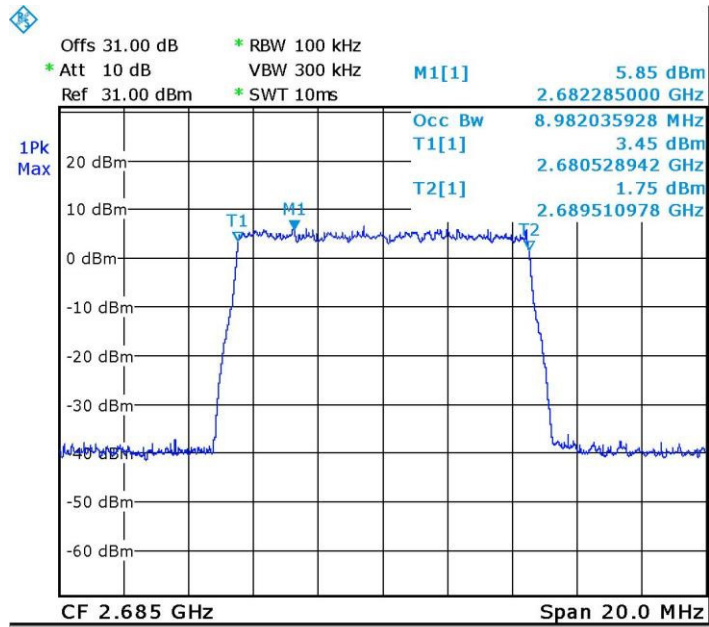
Date: 12.JUL.2016 10:46:22

Figure 41 Occupied Bandwidth INPUT, 2593.0MHz, 16QAM



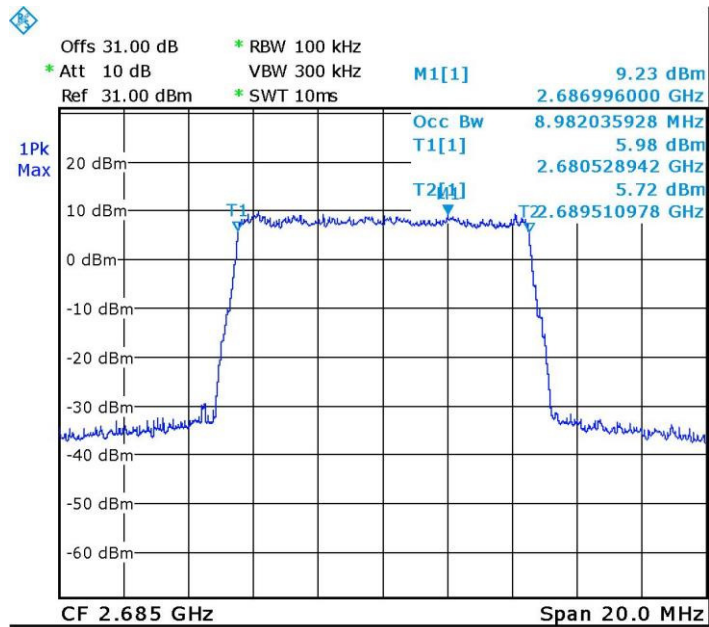
Date: 12.JUL.2016 10:32:53

Figure 42 Occupied Bandwidth OUTPUT, 2593.0MHz, 16QAM



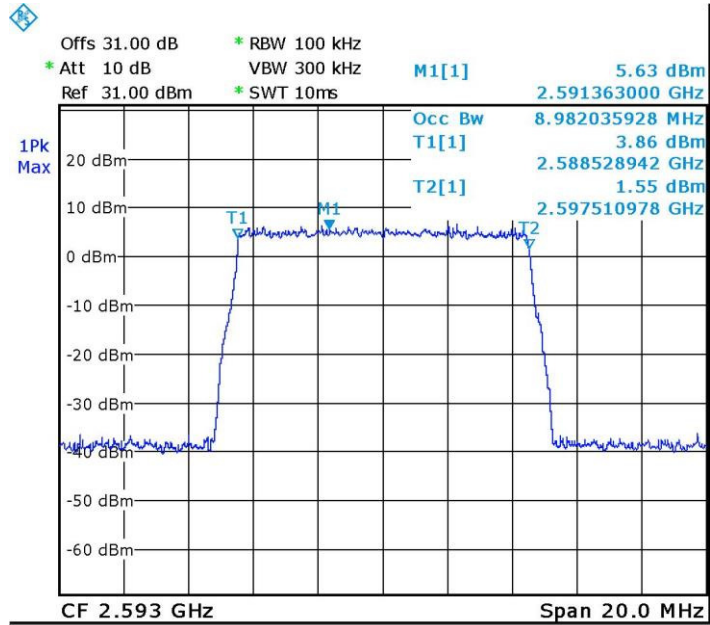
Date: 12.JUL.2016 10:40:32

Figure 43 Occupied Bandwidth INPUT, 2685.0MHz, 16QAM



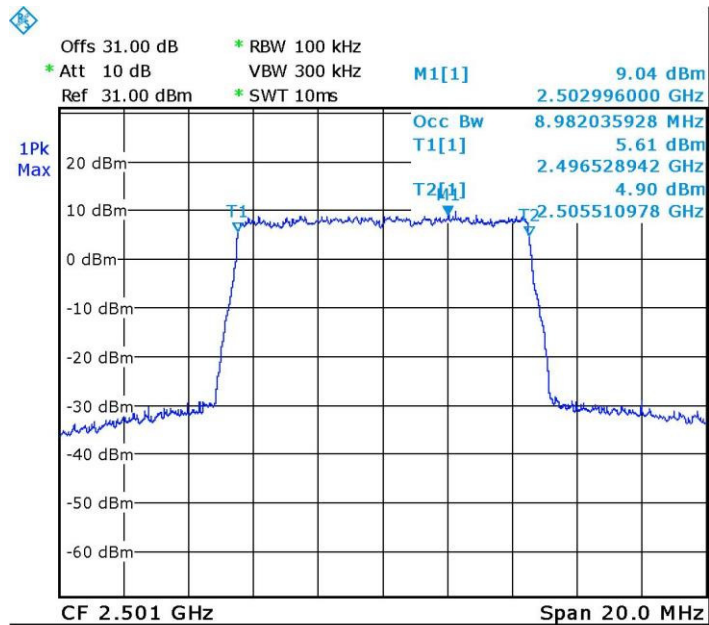
Date: 12.JUL.2016 10:37:28

Figure 44 Occupied Bandwidth OUTPUT, 2685.0MHz, 16QAM



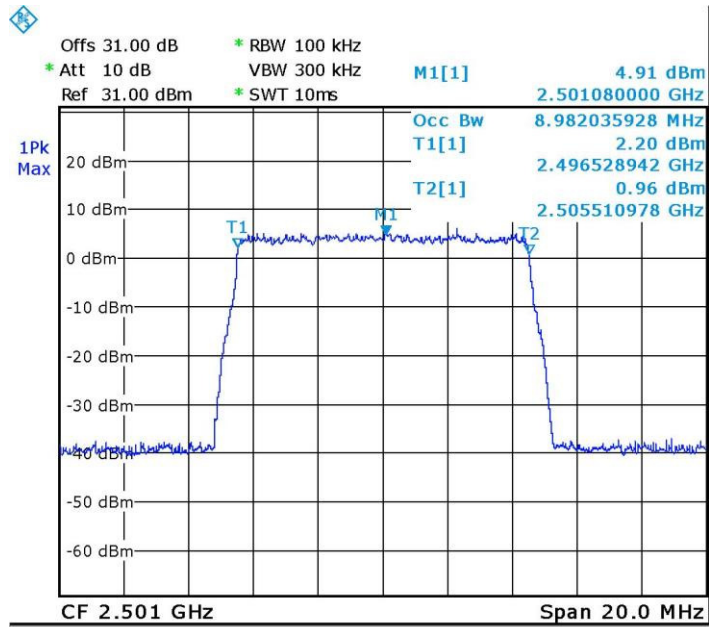
Date: 12.JUL.2016 10:45:31

Figure 45 Occupied Bandwidth INPUT, 2501.0MHz, QPSK



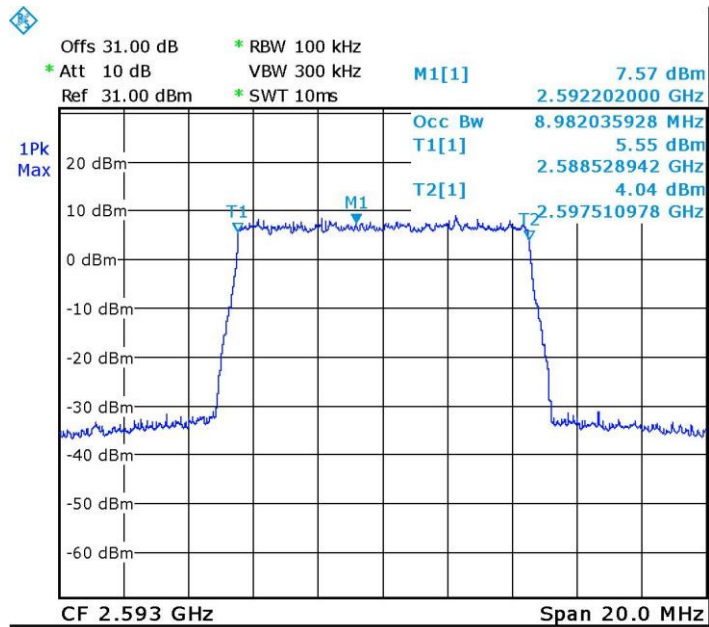
Date: 12.JUL.2016 10:30:59

Figure 46 Occupied Bandwidth OUTPUT, 2501.0MHz, QPSK



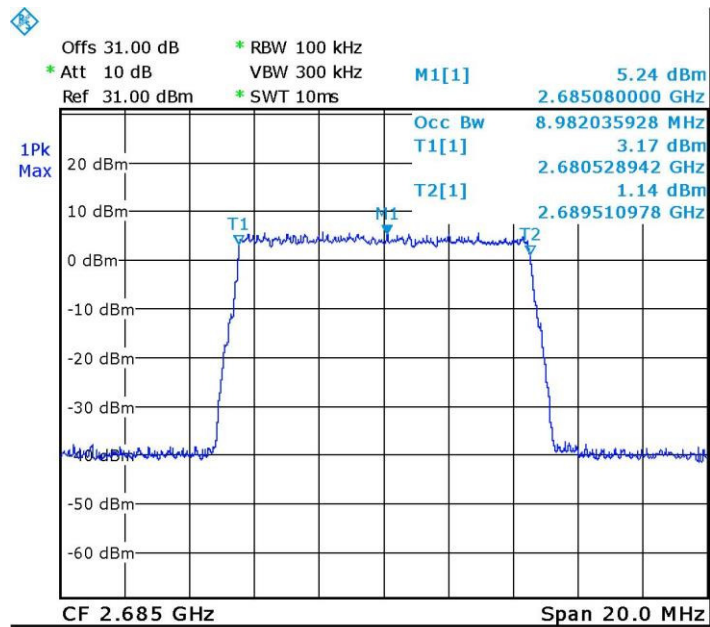
Date: 12.JUL.2016 10:48:00

Figure 47 Occupied Bandwidth INPUT, 2593.0MHz, QPSK



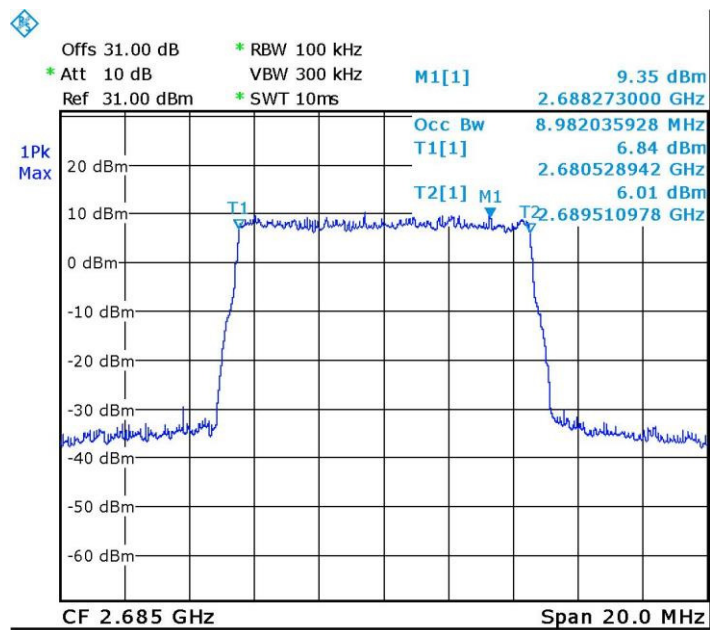
Date: 12.JUL.2016 10:33:28

Figure 48 Occupied Bandwidth OUTPUT, 2593.0MHz, QPSK



Date: 12.JUL.2016 10:41:04

Figure 49 Occupied Bandwidth INPUT, 2685.0MHz, QPSK



Date: 12.JUL.2016 10:37:58

Figure 50 Occupied Bandwidth OUTPUT, 2685.0MHz, QPSK



**6.5 Test Equipment Used; Occupied Bandwidth**

Instrument	Manufacturer	Model	Serial Number	Calibration	
				Last Calibration Date	Next Calibration Date
Spectrum Analyzer	R&S	FSL6	100194	February 29, 2016	March 1, 2017
Vector Signal Generator	Agilent	N5172B	MY51350584	July 1, 2016	July 1, 2017
30 dB Attenuator	MCL	BW-S30W5	533	July 5, 2016	July 5, 2017

**Figure 51 Test Equipment Used**



## 7. Spurious Emissions at Antenna Terminals

### 7.1 Test Specification

FCC Part 27, Subpart C, Section: 53(m)(2)

### 7.2 Test Procedure

(Temperature (22°C)/ Humidity (35%RH))

The E.U.T. antenna terminal was connected to the spectrum analyzer through an external attenuator and an appropriate coaxial cable (max loss 34.0 dB).

The evaluation was performed in the frequency band from 9.0kHz-27.0GHz without band edges tests, and for each modulation separately.

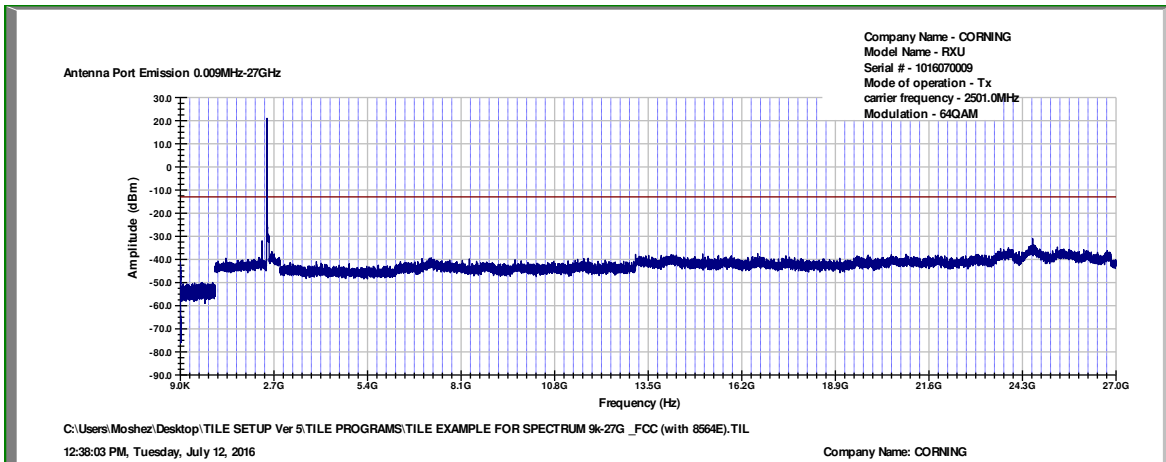
### 7.3 Test Limit

The power of any emission outside of the authorized operating frequency ranges (2496.0-2690.0MHz) must be attenuated below the transmitting power (P) by a factor of at least  $43 + 10 \log (P)$  dB , yielding  $-13\text{dBm}$ .

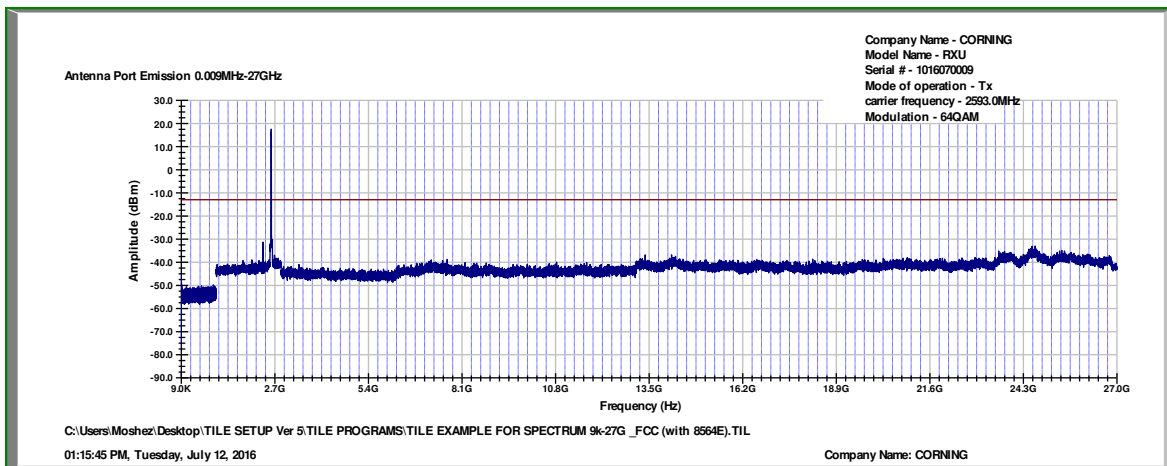
### 7.4 Test Results

JUDGEMENT:                      Passed

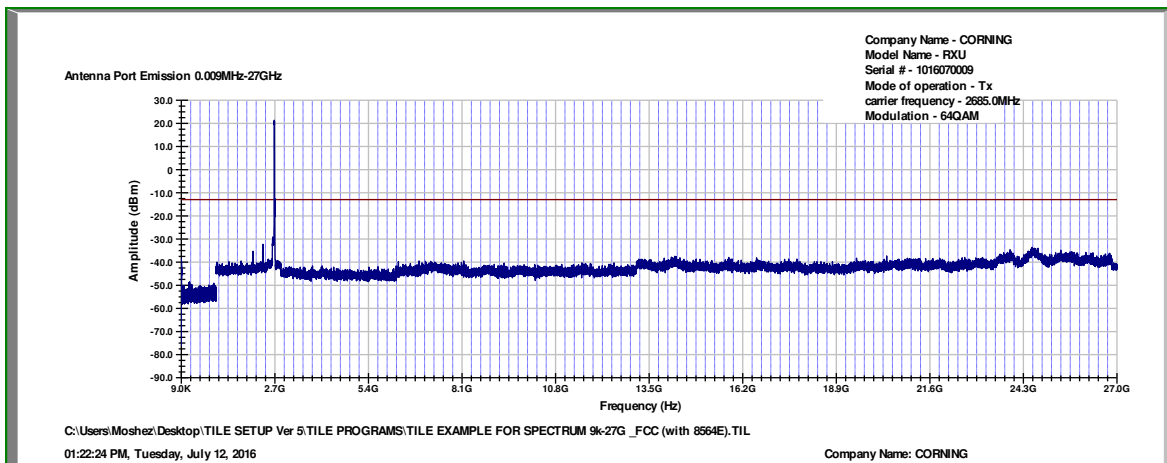
See additional information in *Figure 52* to *Figure 60*.



**Figure 52 Spurious Emissions at Antenna Terminals 64QAM, 2501.0MHz**

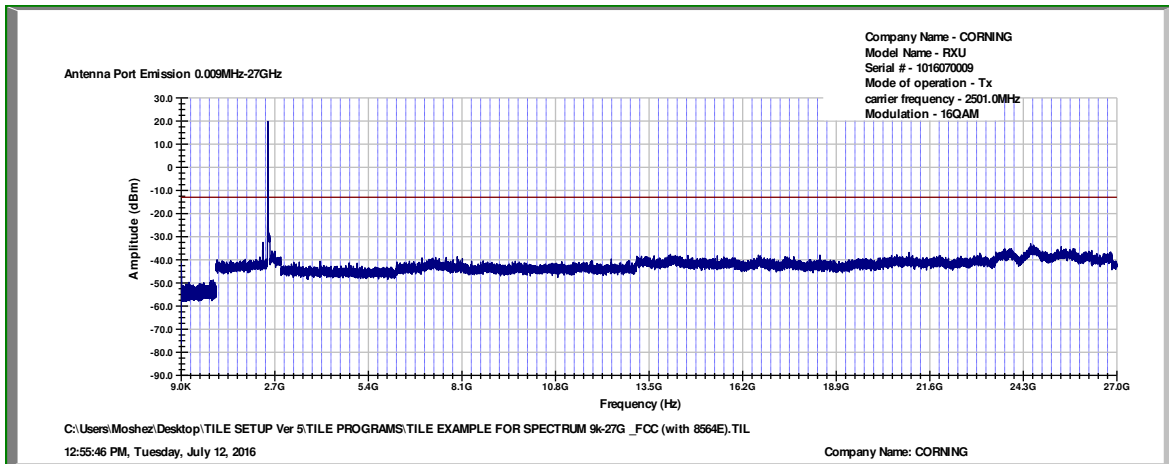


**Figure 53 Spurious Emissions at Antenna Terminals 64QAM, 2593.0MHz**

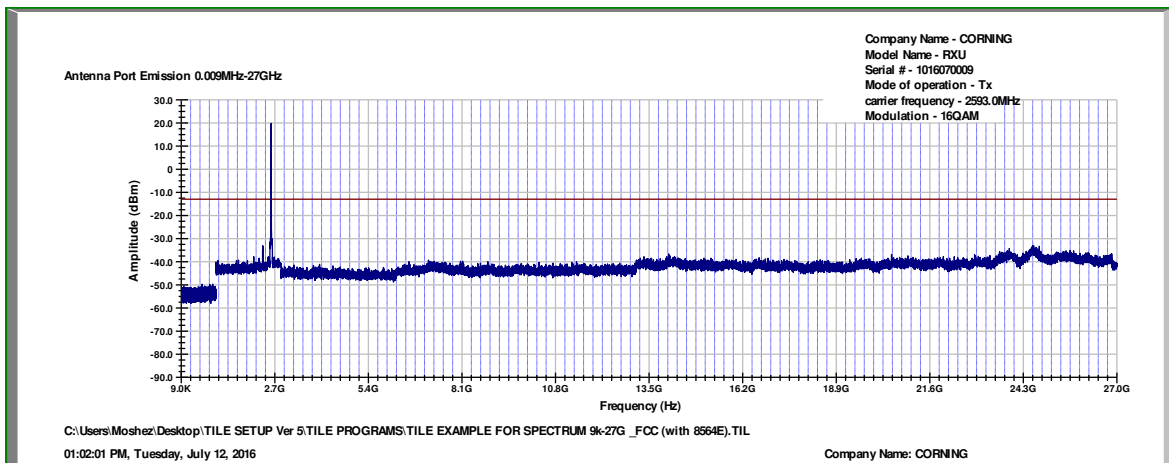


**Figure 54 Spurious Emissions at Antenna Terminals 64QAM, 2685.0MHz**

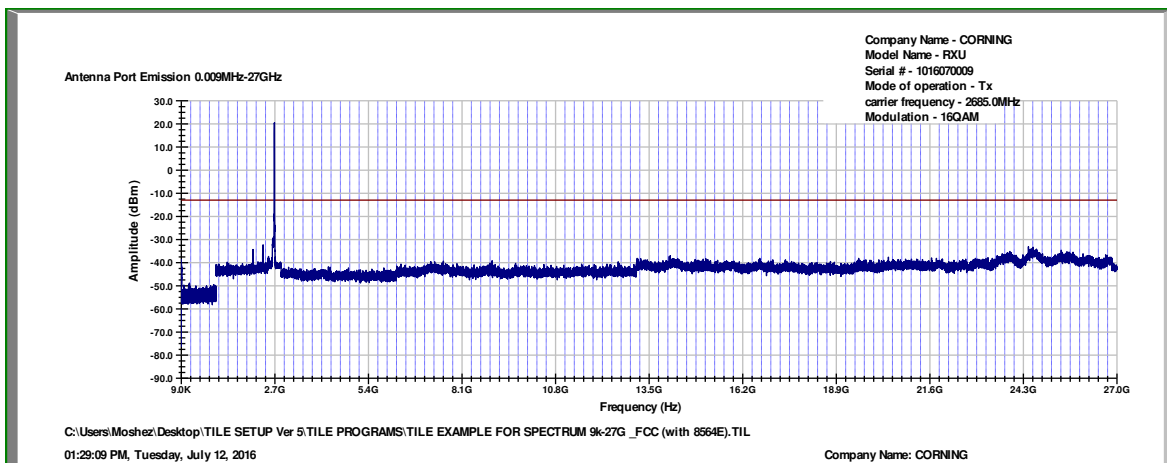




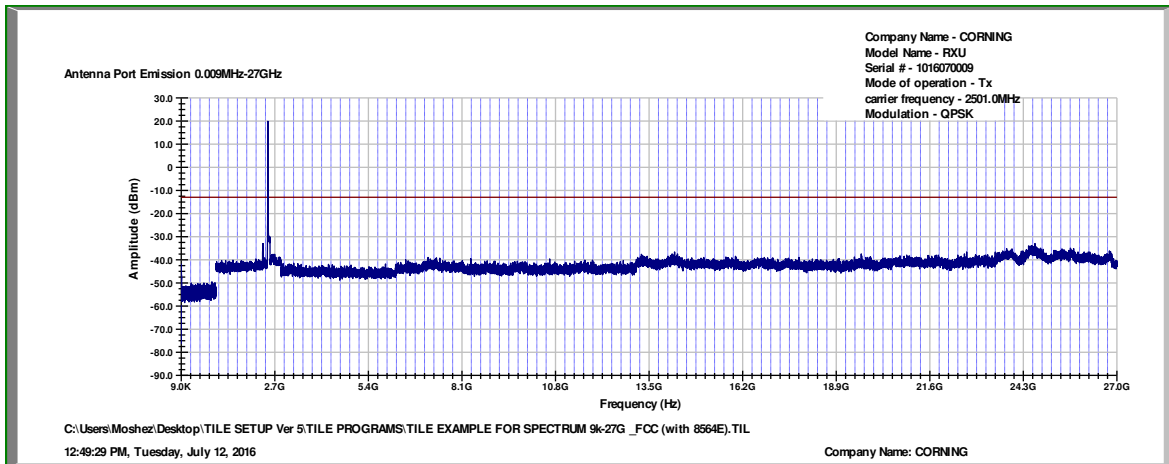
**Figure 55 Spurious Emissions at Antenna Terminals 16QAM, 2501.0MHz**



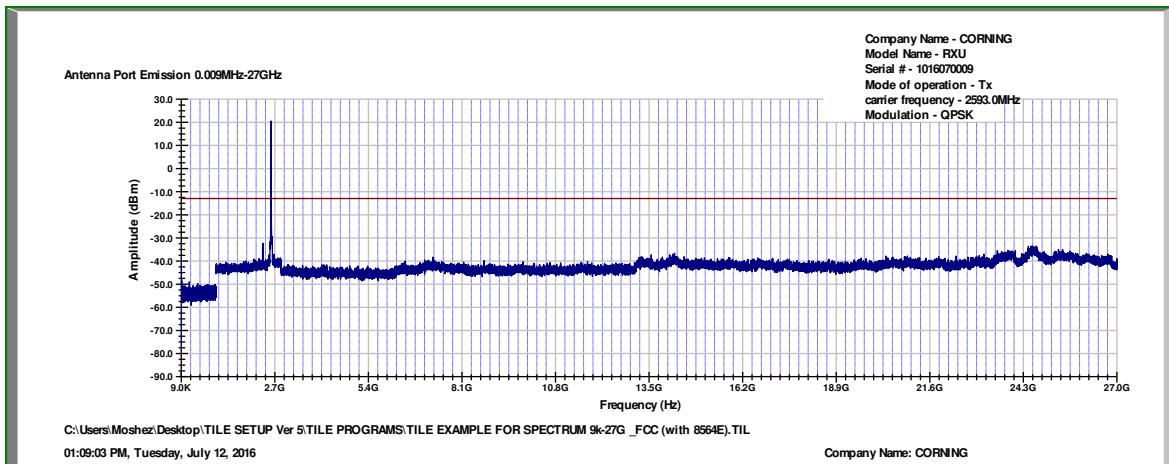
**Figure 56 Spurious Emissions at Antenna Terminals 16QAM, 2593.0MHz**



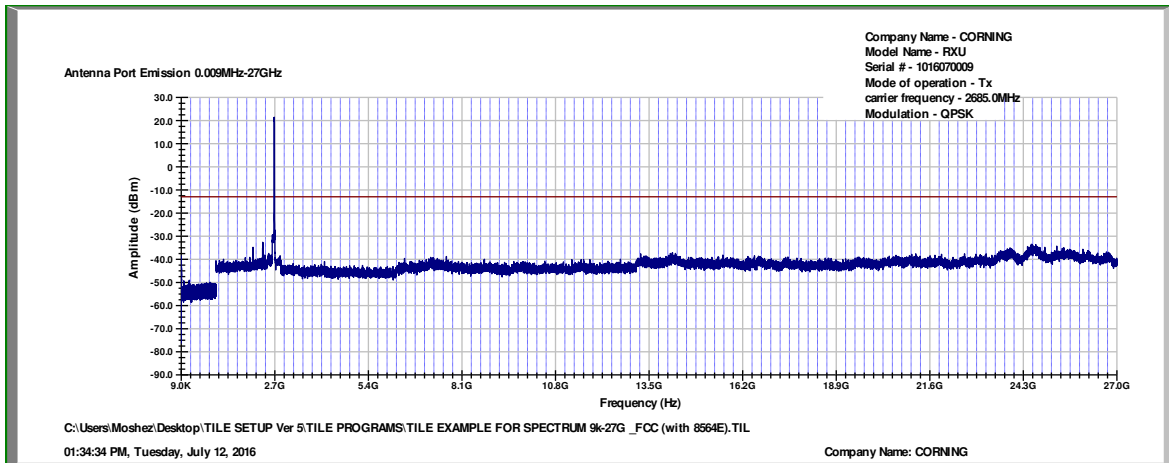
**Figure 57 Spurious Emissions at Antenna Terminals 16QAM, 2685.0MHz**



**Figure 58 Spurious Emissions at Antenna Terminals QPSK, 2501.0MHz**



**Figure 59 Spurious Emissions at Antenna Terminals QPSK, 2593.0MHz**



**Figure 60 Spurious Emissions at Antenna Terminals QPSK, 2685.0MHz**



**7.5 Test Equipment Used; Out of Band Emission at Antenna Terminals**

Instrument	Manufacturer	Model	Serial Number	Calibration	
				Last Calibration Date	Next Calibration Due
EXG Vector Signal Generator	Agilent	N5172B	MY51350584	July 1, 2016	July 1, 2017
Spectrum Analyzer	HP	8564E	3442A00275	March 10, 2016	March 10, 2017
30 dB Attenuator	MCL	BW-S30W5	533	July 5, 2016	July 5, 2017

**Figure 61 Test Equipment Used**

## 8. Band Edge Spectrum

### 8.1 Test Specification

FCC Part 27, Subpart C, Section: 53(m)(2)

### 8.2 Test Procedure

(Temperature (22°C)/ Humidity (35%RH))

The E.U.T. antenna terminal was connected to the spectrum analyzer through an External attenuator and an appropriate coaxial cable (31.0 dB).

The spectrum analyzer RBW was set to 1% from OBW The evaluation was Repeated for all modulations.

### 8.3 Test Limit

The power of any emission outside of the authorized operating frequency ranges must be attenuated below the transmitting power (P) by factor of at least  $43 + 10 \log (P)$  dB , yielding -13dBm.

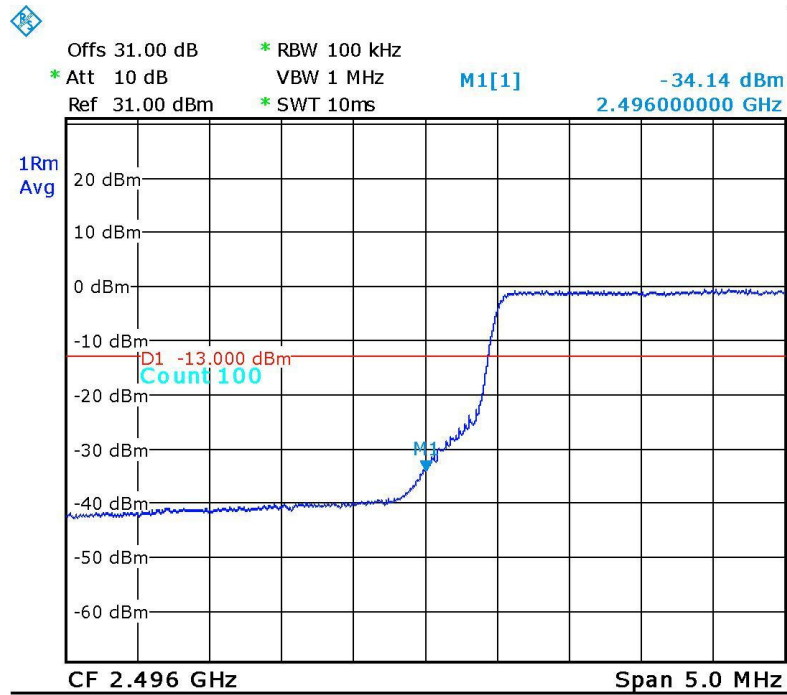
### 8.4 Test Results

Modulation	Operation Frequency	Band Edge Frequency	Reading	Limit	Margin
	(MHz)	(MHz)	(dBm)	(dBm)	(dB)
64QAM	2501.0	2496.0	-34.1	-13.0	-21.1
	2685.0	2690.0	-32.0	-13.0	-19.0
16QAM	2501.0	2496.0	-18.1	-13.0	-5.1
	2685.0	2690.0	-16.6	-13.0	-3.6
QPSK	2501.0	2496.0	-18.2	-13.0	-5.2
	2685.0	2690.0	-15.5	-13.0	-2.5

Figure 62 Band Edge Spectrum Results

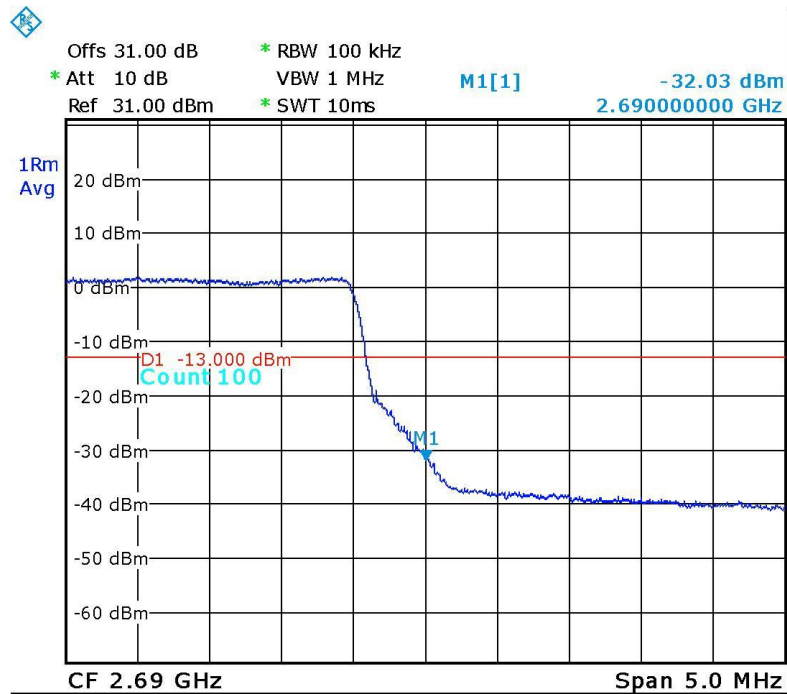
JUDGEMENT: Passed by 2.5dB

See additional information in *Figure 63* to *Figure 68*.



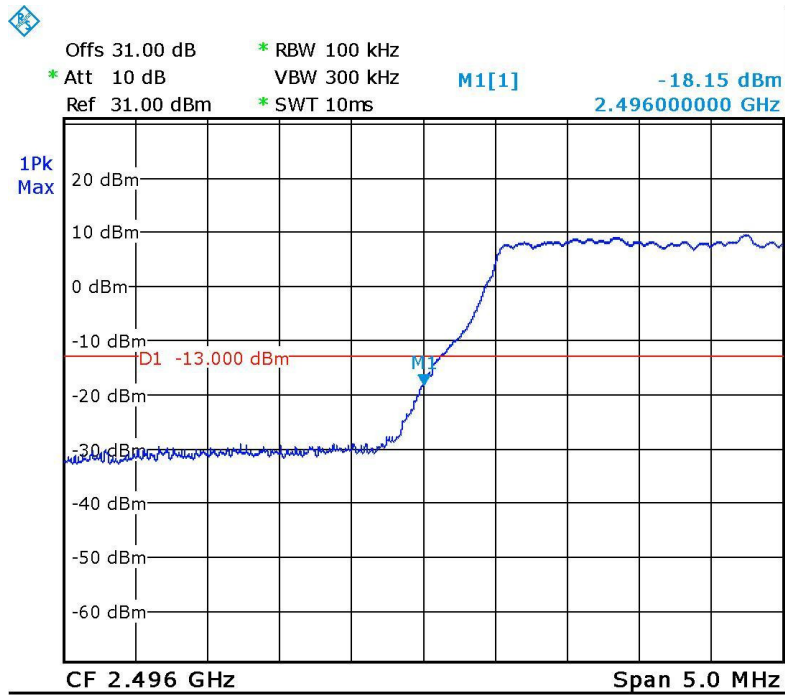
Date: 12.JUL.2016 11:20:42

Figure 63. — Band Edge – Low, 64QAM



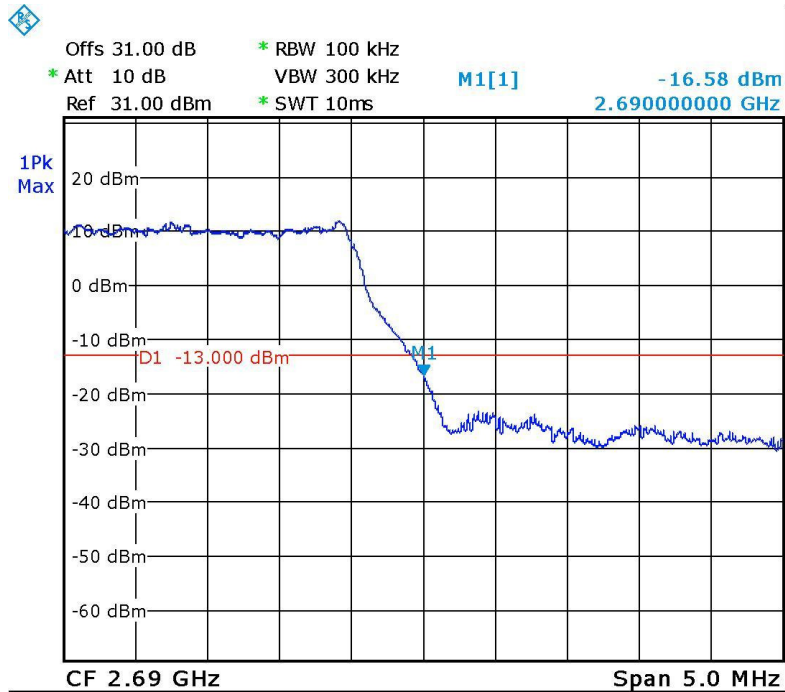
Date: 12.JUL.2016 11:19:07

Figure 64. — Band Edge – High, 64QAM



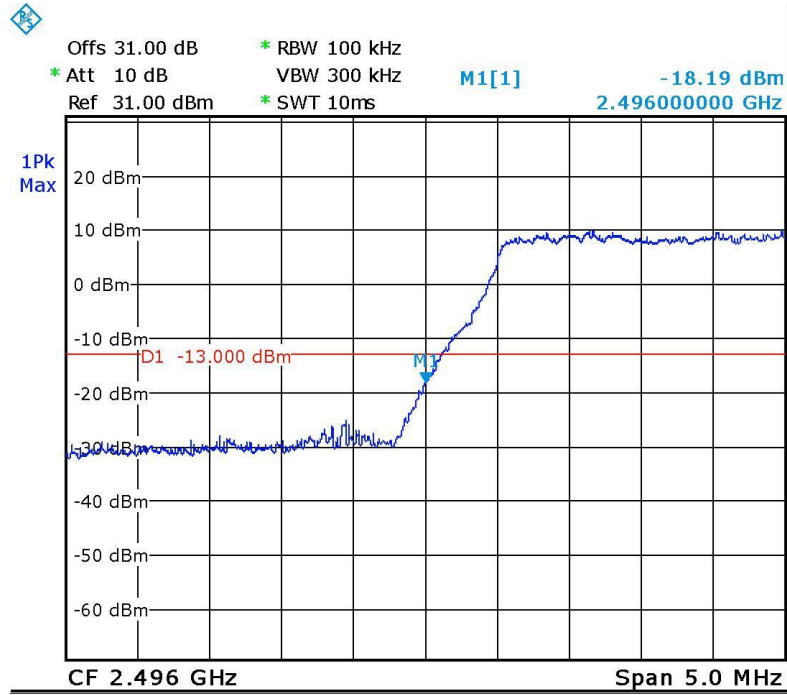
Date: 12.JUL.2016 11:12:45

Figure 65. — Band Edge – Low, 16QAM



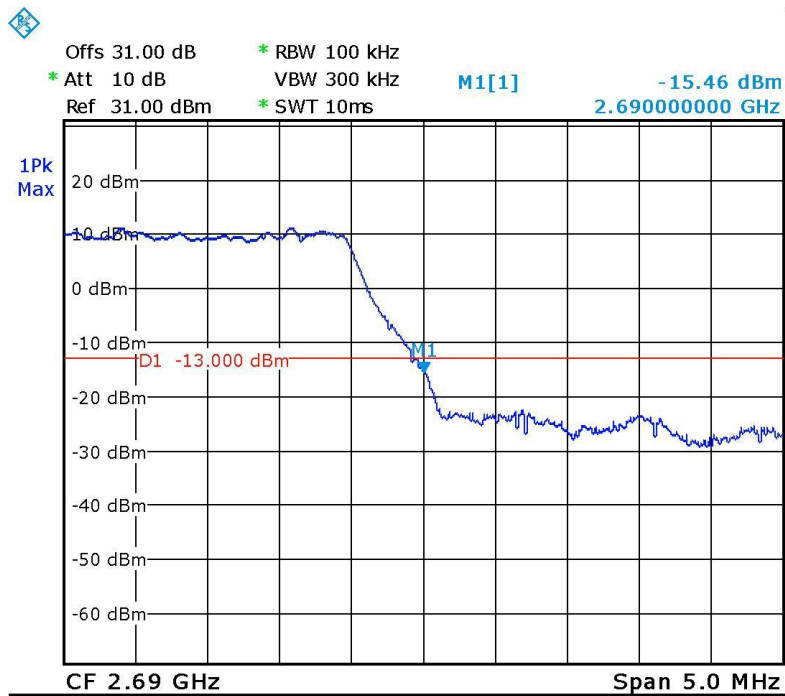
Date: 12.JUL.2016 11:15:04

Figure 66. — Band Edge – High, 16QAM



Date: 12.JUL.2016 11:11:26

Figure 67. — Band Edge – Low, QPSK



Date: 12.JUL.2016 11:16:46

Figure 68. — Band Edge – High, QPSK



### 8.5 Test Equipment Used; Band Edge Spectrum

Instrument	Manufacturer	Model	Serial Number	Calibration	
				Last Calibration Date	Next Calibration Date
Spectrum Analyzer	R&S	FSL6	100194	February 29, 2016	March 1, 2017
Vector Signal Generator	Agilent	N5172B	MY51350584	July 1, 2016	July 1, 2017
30 dB Attenuator	MCL	BW-S30W5	533	July 5, 2016	July 5, 2017

Figure 69 Test Equipment Used



## 9. Spurious Emissions (Radiated)

### 9.1 Test Specification

FCC Part 27.53

### 9.2 Test Procedure

(Temperature (23°C)/ Humidity (54%RH))

The test method was based on ANSI/TIA-603-D: 2010, Section 2.2.12 Unwanted Emissions: Radiated Spurious.

The E.U.T. operation mode and test set-up are as described in Section 2 of this report.

#### **For measurements between 0.009MHz-30.0MHz:**

The E.U.T was tested inside the shielded room at a distance of 3 meters and the E.U.T was placed on a non-metallic table, 1.5 meters above the ground. The frequency range 0.009MHz-30MHz was scanned. The readings were maximized by the turntable azimuth between 0-360°, and the antenna polarization.

The emissions were measured at a distance of 3 meters.

#### **For measurements between 30.0MHz-1.0GHz:**

A preliminary measurement to characterize the E.U.T was performed inside the shielded room at a distance of 3 meters, using peak detection mode and broadband antennas. The preliminary measurements produced a list of the highest emissions. The E.U.T was then transferred to the open site, and placed on a remote-controlled turntable. The E.U.T was placed on a non-metallic table, 1.0 meters above the ground. The frequency range 30.0MHz -1.0GHz was scanned and the list of the highest emissions was verified and updated accordingly.

The readings were maximized by adjusting the antenna height between 1-4 meters, the turntable azimuth between 0-360°, and the antenna polarization.

The emissions were measured at a distance of 3 meters.

#### **For measurements between 1.0GHz-27.0GHz:**

The E.U.T was tested inside the shielded room at a distance of 3 meters and the E.U.T was placed on a non-metallic table, 1.5 meters above the ground. The frequency range 1.0GHz -27.0GHz was scanned. The readings were maximized by the turntable azimuth between 0-360°, and the antenna polarization.

The emissions were measured at a distance of 3 meters.

The E.U.T. was replaced by a substitution antenna (dipole 30MHz-1GHz, Horn Antenna above 1GHz) driven by a signal generator.

The height was readjusted for maximum reading. The signal generator level was adjusted to obtain the same reading on the EMI receiver as in step (a).

The signals observed in step (a) were converted to radiated power using:

$$P_d(\text{dBm}) = P_g(\text{dBm}) - \text{Cable Loss (dB)} + \text{Substitution Antenna Gain (dBd)}$$

$P_d$  = Dipole equivalent power (result).

$P_g$  = Signal generator output level.

A Peak detector was used for this test.



Testing was performed in 3 operational frequencies: low, mid and high.  
Testing was performed with the RF port connected to 50 Ω termination.  
The table below describe only results with the highest radiation.

### 9.3 Test Limit

The power of any emission outside of the authorized operating frequency ranges must be attenuated below the transmitting power (P) by factor of at least  $43 + 10 \log (P)$  dB, yielding -13dBm.

### 9.4 Test Results

Carrier Channel	Freq.	Antenna Pol.	Maximum Peak Level	Signal Generator RF Output	Cable Loss	Antenna Gain	Effective Radiated Power Level	Limit	Margin
(MHz)	(MHz)	(V/H)	(dBμV/m)	(dBm)	(dB)	(dBd)	(dBm)	(dBm)	(dB)
2501.0	5002.0	V	33.4	-69.8	0.5	8.7	-61.6	-13.0	-48.6
	5002.0	H	33.5	-68.6	0.5	8.7	-60.4	-13.0	-47.4
2685.0	5370.0	V	33.7	-69.5	0.5	8.7	-61.3	-13.0	-48.3
	5370.0	H	33.9	-68.3	0.5	8.7	-60.1	-13.0	-47.1
2593.0	5186.0	V	33.8	-69.5	0.5	8.7	-61.3	-13.0	-48.3
	5186.0	H	33.6	-68.6	0.5	8.7	-60.4	-13.0	-47.4

Figure 70 Spurious Emission (Radiated)

JUDGEMENT; Passed by 47.1 dB  
The E.U.T met the requirements of the FCC Part 27, Section 53 specification.



**9.5 Test Instrumentation Used, Radiated Measurements**

Instrument	Manufacturer	Model	Serial Number	Calibration	
				Last Calibration Date	Next Calibration Due
EMI Receiver	HP	85422E	3906A00276	March 3, 2016	March 3, 2017
RF Filter Section	HP	85420E	3705A00248	March 3, 2016	March 3, 2017
EMI Receiver	R&S	ESCI7	100724	February 29, 2016	March 1, 2017
Spectrum Analyzer	HP	8593EM	3536A00120ADI	March 10, 2016	March 10, 2017
Active Loop Antenna	EMCO	6502	9506-2950	November 5, 2015	November 30, 2016
Antenna Biconical	EMCO	3110B	9912-3337	March 24, 2016	March 24, 2018
Antenna Log Periodic	EMCO	3146	9505-4081	April 23, 2016	April 23, 2017
Horn Antenna 1G-18G	ETS	3115	29845	May 19, 2015	May 19, 2018
Horn Antenna 18G-26G	ARA	SWH-28	1007	March 30, 2014	September 30, 2016
Low Noise Amplifier	Narda	LNA-DBS-0411N313	013	March 1, 2015	September 30, 2016
Low Noise Amplifier	Sophia Wireless	LNA 28-B	232	March 1, 2015	September 30, 2016
MXG Vector Signal generator	Agilent	N5182A	MY49060440	July 1, 2016	July 1, 2017
Semi Anechoic Civil Chamber	ETS	S81	SL 11643	N/A	N/A
Antenna Mast	ETS	2070-2	-	N/A	N/A
Turntable	ETS	2087	-	N/A	N/A
Mast & Table Controller	ETS/EMCO	2090	9608-1456	N/A	N/A

**Figure 71 Test Equipment Used**

## 10. Intermodulation Conducted

### 10.1 Test Procedure

(Temperature (22°C)/ Humidity (37%RH))

The E.U.T. antenna terminal was connected to the spectrum analyzer through an external attenuator and an appropriate coaxial cable (max loss = 34.0dB). The spectrum analyzer was set to 1 kHz resolution BW for the frequency range 9.0-150.0 kHz, 10 kHz for the frequency range 150 kHz–1.0 MHz, 100 kHz for the frequency range 1.0 MHz – 30 MHz, and 1MHz for the frequency range 30 MHz - 27GHz.

2 input signals were sent simultaneously to the E.U.T. as follows:

WCS band: 2355.0 MHz, 0 dBm

TDD 2.5G band: 2593.0 MHz, 0 dBm

The frequency range of 9 kHz – 27.0 GHz was scanned for unwanted signals.

### 10.2 Test Limit

The power of any emission outside of the authorized operating frequency ranges must be attenuated below the transmitting power (P) by a factor of at least  $43 + 10 \log (P)$  dB, yielding -13dBm.

### 10.3 Test Results

JUDGEMENT: Passed

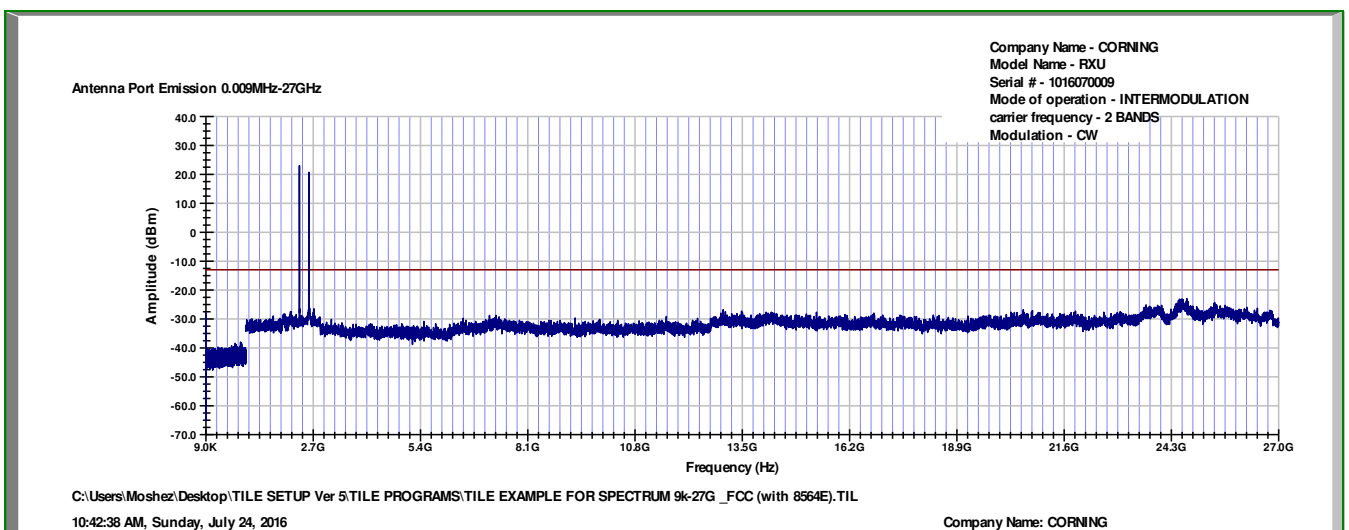


Figure 72 Intermodulation Conducted



### 10.4 Test Equipment Used; Intermodulation Conducted

Instrument	Manufacturer	Model	Serial Number	Calibration	
				Last Calibration Date	Next Calibration Date
Spectrum Analyzer	HP	8564E	3442A00275	March 10, 2016	March 10, 2017
EXG Vector Signal Generator	Agilent	N5172B	TE4384	July 1, 2016	July 1, 2017
EXG Vector Signal Generator	Agilent	N5172B	MY513500584	July 1, 2016	July 1, 2017
30 dB Attenuator	MCL	BW-S30W5	533	July 5, 2016	July 5, 2017

Figure 73 Test Equipment Used

# 11. Intermodulation Radiated

## 11.1 Test Procedure

The test method was based on ANSI/TIA-603-D: 2010, Section 2.2.12 Unwanted Emissions: Radiated Spurious.

### **For measurements between 0.009MHz-30.0MHz:**

The E.U.T was tested inside the shielded room at a distance of 3 meters and the E.U.T was placed on a non-metallic table, 1.5 meters above the ground. The frequency range 0.009MHz-30MHz was scanned. The readings were maximized by the turntable azimuth between 0-360°, and the antenna polarization. The emissions were measured at a distance of 3 meters.

### **For measurements between 30.0MHz-1.0GHz:**

A preliminary measurement to characterize the E.U.T was performed inside the shielded room at a distance of 3 meters, using peak detection mode and broadband antennas. The preliminary measurements produced a list of the highest emissions. The E.U.T was then transferred to the open site, and placed on a remote-controlled turntable. The E.U.T was placed on a non-metallic table, 1.0 meters above the ground. The frequency range 30.0MHz -1.0GHz was scanned and the list of the highest emissions was verified and updated accordingly.

The readings were maximized by adjusting the antenna height between 1-4 meters, the turntable azimuth between 0-360°, and the antenna polarization.

The emissions were measured at a distance of 3 meters.

### **For measurements between 1.0GHz-27.0GHz:**

The E.U.T was tested inside the shielded room at a distance of 3 meters and the E.U.T was placed on a non-metallic table, 1.5 meters above the ground. The frequency range 1.0GHz -27.0GHz was scanned. The readings were maximized by the turntable azimuth between 0-360°, and the antenna polarization. The emissions were measured at a distance of 3 meters.

The E.U.T. was replaced by a substitution antenna (dipole 30MHz-1GHz, Horn Antenna above 1GHz) driven by a signal generator.

The height was readjusted for maximum reading. The signal generator level was adjusted to obtain the same reading on the EMI receiver as in step (a).

The signals observed in step (a) were converted to radiated power using:

$$P_d(\text{dBm}) = P_g(\text{dBm}) - \text{Cable Loss (dB)} + \text{Substitution Antenna Gain (dBd)}$$

$P_d$  = Dipole equivalent power (result).

$P_g$  = Signal generator output level.

A Peak detector was used for this test.

Testing was performed when the RF port was connected to 50  $\Omega$  termination.

The table below describe only results with the highest radiation.

2 input signals were sent simultaneously to the E.U.T. as follows:

WCS band: 2355.0MHz, 0 dBm

TDD 2.5G band: 2593.0MHz, 0 dBm



### 11.2 Test Limit

The power of any emission outside of the authorized operating frequency ranges must be attenuated below the transmitting power (P) by factor of at least  $43 + 10 \log (P)$  dB , yielding -13dBm.

### 11.3 Test Results

Freq.	Antenna Pol.	Maximum Peak Level	Signal Generator RF Output	Cable Loss	Antenna Gain	Effective Radiated Power Level	Limit	Margin
(MHz)	(V/H)	(dBμV/m)	(dBm)	(dB)	(dBd)	(dBm)	(dBm)	(dB)
1403.0	V	38.4	-61.2	0.5	6.0	-55.7	-13.0	-42.7
1403.0	H	38.4	-61.1	0.5	6.0	-55.6	-13.0	-42.6
1641.0	V	38.5	-61.6	0.5	6.0	-56.1	-13.0	-43.1
1641.0	H	38.6	-60.6	0.5	6.0	-55.1	-13.0	-42.1
1879.0	V	39.0	-60.6	0.5	6.0	-55.1	-13.0	-42.1
1879.0	H	38.8	-60.4	0.5	6.0	-54.9	-13.0	-41.9
2117.0	V	39.3	-65.6	0.5	10.0	-56.1	-13.0	-43.1
2117.0	H	39.1	-60.8	0.5	7.0	-54.3	-13.0	-41.3
2831.0	V	40.4	-64.3	0.5	10.0	-54.8	-13.0	-41.8
2831.0	H	40.8	-63.5	0.5	10.0	-54.0	-13.0	-41.0
3069.0	V	42.5	-62.9	0.5	10.0	-53.4	-13.0	-42.7
3069.0	H	42.4	-61.5	0.5	10.0	-52.0	-13.0	-42.6
3307.0	V	45.6	-59.9	0.5	10.0	-50.4	-13.0	-43.1
3307.0	H	45.6	-58.5	0.5	10.0	-49.0	-13.0	-42.1
3545.0	V	47.3	-55.1	0.5	9.5	-46.1	-13.0	-42.1
3545.0	H	47.4	-55.7	0.5	9.5	-46.7	-13.0	-41.9

Figure 74 Intermodulation Radiated Results

JUDGEMENT: Passed



**11.4 Test Instrumentation Used; Radiated Measurements Intermodulation**

Instrument	Manufacturer	Model	Serial Number	Calibration	
				Last Calibration Date	Next Calibration Due
EMI Receiver	HP	85422E	3906A00276	March 3, 2016	March 3, 2017
RF Filter Section	HP	85420E	3705A00248	March 3, 2016	March 3, 2017
EMI Receiver	R&S	ESCI7	100724	February 29, 2016	March 1, 2017
Spectrum Analyzer	HP	8593EM	3536A00120ADI	March 10, 2016	March 10, 2017
Active Loop Antenna	EMCO	6502	9506-2950	November 5, 2015	November 30, 2016
Antenna Biconical	EMCO	3104	2606	March 24, 2016	March 24, 2017
Antenna Log Periodic	EMCO	3146	9505-4081	April 23, 2016	April 23, 2017
Horn Antenna 1G-18G	ETS	3115	29845	May 19, 2015	May 19, 2018
Horn Antenna 18G-26G	ARA	SWH-28	1007	March 30, 2014	September 30, 2016
Low Noise Amplifier	Narda	LNA-DBS-0411N313	013	March 1, 2015	September 30, 2016
Low Noise Amplifier	Sophia Wireless	LNA 28-B	232	March 1, 2015	September 30, 2016
ESG Vector Signal Generator	Agilent	E4438C	MY45094064	July 1, 2016	July 1, 2017
Signal Generator	Agilent	E4432B	GB40050998	July 1, 2016	July 1, 2017
Semi Anechoic Civil Chamber	ETS	S81	SL 11643	N/A	N/A
Antenna Mast	ETS	2070-2	-	N/A	N/A
Turntable	ETS	2087	-	N/A	N/A
Mast & Table Controller	ETS/EMCO	2090	9608-1456	N/A	N/A

**Figure 75 Test Equipment Used**



## 12. Out-of-Band Rejection (TDD)

### 12.1 Test Specification

KDB 935210 D05 v01r01, Section 3.3

### 12.2 Test Procedure

(Temperature (22°C)/ Humidity (37%RH))

The E.U.T. antenna terminal was connected to the spectrum analyzer through an external attenuator and an appropriate coaxial cable (max Loss= 41.5 dB).

The signal and spectrum analyzer frequency range was set to  $\pm 250\%$  of the passband, Dwell time set to approximately 10msec.

RBW was set between 1% to 5% of the E.U.T passband and VBW set to  $\geq 3 * RBW$ .

### 12.3 Test Limit

N/A

### 12.4 Test Results

JUDGEMENT: Passed

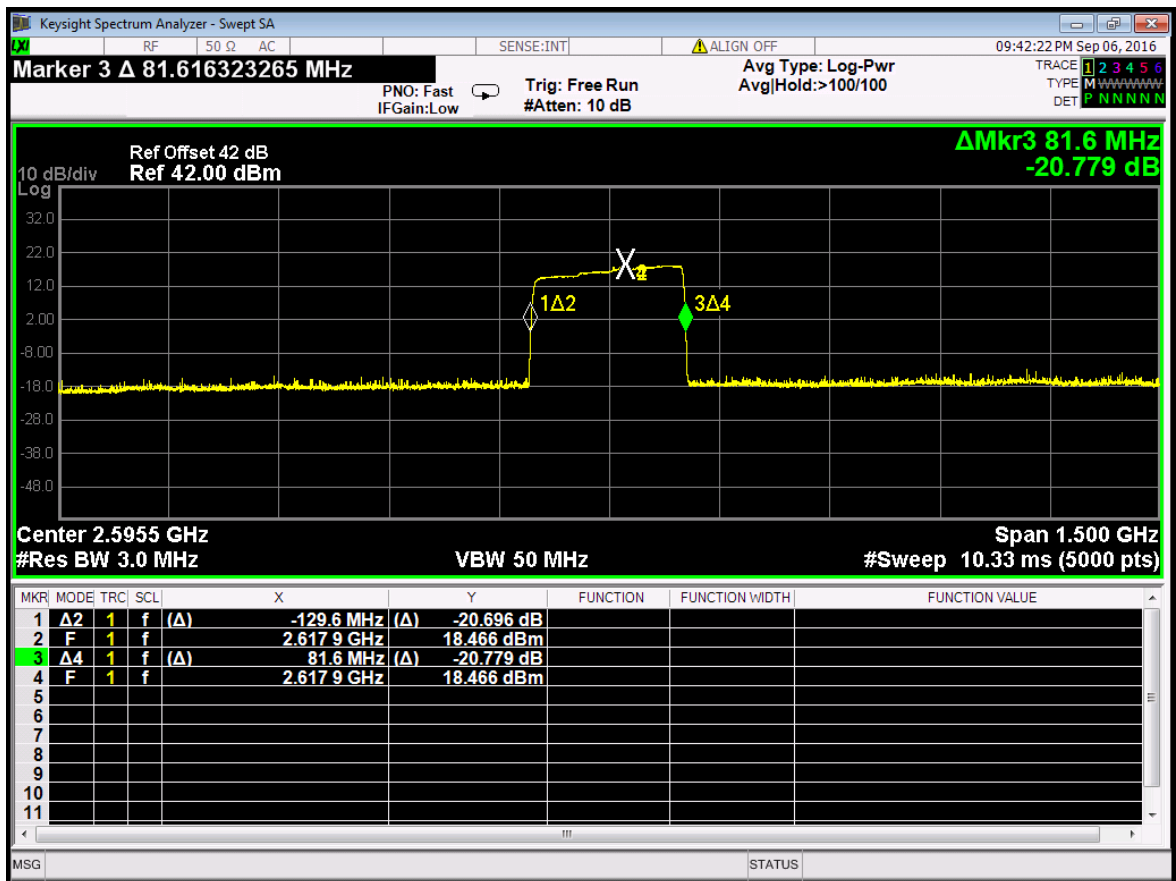


Figure 76. — Out-of-Band Rejection Plot



**12.5 Test Equipment Used; Out-of-Band Rejection**

Instrument	Manufacturer	Model	Serial Number	Calibration	
				Last Calibration Date	Next Calibration Date
EXA Spectrum Analyzer	Agilent	N9010A	MY49061070	July 21, 2016	July 21, 2017
EXG Vector Signal Generator	Agilent	N5172B	MY51350584	July 1, 2016	July 1, 2017
40 dB Attenuator	Weinschel	WA 39-40-33	A1323	April 3, 2016	April 3, 2017

**Figure 77 Test Equipment Used**



## 13. APPENDIX A - CORRECTION FACTORS

### 13.1 Correction factors for RF OATS Cable 35m ITL #1784

Frequency ( MHz)	Cable loss (dB)
10.0	0.3
20.0	0.2
50.0	-0.1
100.0	-0.6
200.0	-1.2
500.0	-2.3
1000.0	-3.6



**13.2 Correction factors for RF OATS Cable 10m  
ITL #1794**

Frequency(MHz)	Cable loss(dB)
10.0	-0.3
20.0	-0.3
50.0	-0.5
100.0	-0.7
200.0	-1.1
500.0	-1.8
1000.0	-2.7



**13.3 Correction factors for**

**Horn Antenna  
Model: SWH-28  
at 1 meter range.**

<b>FREQUENCY (GHz)</b>	<b>AFE (dB /m)</b>	<b>Gain (dB1)</b>
18.0	40.3	16.1
19.0	40.3	16.3
20.0	40.3	16.1
21.0	40.3	16.3
22.0	40.4	16.8
23.0	40.5	16.4
24.0	40.5	16.6
25.0	40.5	16.7
26.0	40.6	16.4



**13.4 Correction factors for Horn ANTENNA**  
**Model: 3115**  
**Antenna serial number: 29845**  
**3 meter range**

f(GHz)	AF(dB/m)	GA(dB)
0.75	25	3
1G	23.5	7
1.5G	26	8
2G	29	7
2.5G	27.5	10
3G	30	10
3.5G	31.5	10
4G	32.5	9.5
4.5G	32.5	10.5
5G	33	10.5
5.5G	35	10.5
6G	36.5	9.5
6.5G	36.5	10
7G	37.5	10
7.5G	37.5	10
8G	37.5	11
8.5G	38	11
9G	37.5	11.5
9.5G	38	11.5
10G	38.5	11.5
10.5G	38.5	12
11G	38.5	12.5
11.5G	38.5	13
12G	38	13.5
12.5G	38.5	13
13G	40	12
13.5G	41	12
14G	40	13
14.5G	39	14
15G	38	15.5
15.5G	37.5	16
16G	37.5	16
16.5G	39	15
17G	40	15
17.5G	42	13.5
18G	42.5	13



**13.5 Correction factors for Log Periodic Antenna  
EMCO, Model 3146,  
Serial #9505-4081**

Frequency [MHz]	AF [dB/m]
200.0	11.47
250.0	12.06
300.0	14.77
400.0	15.77
500.0	18.01
600.0	18.84
700.0	20.93
800.0	21.27
900.0	22.44
1000.0	24.10



**13.6 Correction factors for Biconical Antenna  
EMCO, Model 3110B,  
Serial #9912-3337**

Frequency [MHz]	AF [dB/m]
30.0	14.18
35.0	13.95
40.0	12.84
45.0	11.23
50.0	11.10
60.0	10.39
70.0	9.34
80.0	9.02
90.0	9.31
100.0	8.95
120.0	11.53
140.0	12.20
160.0	12.56
180.0	13.49
200.0	15.27





**13.7 Correction factors for ACTIVE LOOP ANTENNA**  
**Model 6502**  
**S/N 9506-2950**

f(MHz)	MAF(dBs/m)	AF(dB/m)
0.01	-33.1	18.4
0.02	-37.2	14.3
0.03	-38.2	13.3
0.05	-39.8	11.7
0.1	-40.1	11.4
0.2	-40.3	11.2
0.3	-40.3	11.2
0.5	-40.3	11.2
0.7	-40.3	11.2
1	-40.1	11.4
2	-40	11.5
3	-40	11.5
4	-40.1	11.4
5	-40.2	11.3
6	-40.4	11.1
7	-40.4	11.1
8	-40.4	11.1
9	-40.5	11
10	-40.5	11
20	-41.5	10
30	-43.5	8