



DATE: 21 March 2021

I.T.L. (PRODUCT TESTING) LTD. FCC Radio Test Report

Equipment under test:

**ONE - Optical Network Evolution Wireless
Platform**

RAU-5 Remote Antenna Unit

(PCS Section)

Tested by:

M. Zohar

Approved by:

D. Shidlowsky

This report must not be reproduced, except in full, without the written permission of I.T.L. (Product Testing) Ltd.

This report relates only to items tested.



Measurement/Technical Report for Corning Optical Communication Wireless ONE - Optical Network Evolution Wireless Platform

FCC ID: OJF1RAU5

This report concerns: Original Grant:
 Class II change: X
 Class I change:

Equipment type: B21 - Part 20 Industrial Booster (CMRS)

Limits used: 47CFR Parts 2; 24

Measurement procedure used is KDB 935210 D05 v01r03 April 2019 and
ANSI IEEE C63.26-2015

Substitution Method used as in ANSI TIA-603-E-2016

Application for Certification
prepared by:
D. Shidlowky
ITL (Product Testing) Ltd.
1 Bat Sheva St.
Lod 7120101
Israel
e-mail davids@iltglobal.org

Applicant for this device:
(different from "prepared by")
Isaac Nissan
Corning Optical Communication Wireless
8253 1st Street
Vienna, VA 22812
U.S.A.
Tel: +1-703 855-1773
e-mail: NissanI@corning.com



TABLE OF CONTENTS

1	GENERAL INFORMATION -----	4
1.1	Administrative Information	4
1.2	List of Accreditations	5
1.3	Product Description	6
1.4	Test Methodology	6
1.5	Test Facility	6
1.6	Measurement Uncertainty	7
2	SYSTEM TEST CONFIGURATION -----	8
2.1	Justification	8
2.2	EUT Exercise Software	8
2.3	Special Accessories	8
2.4	Equipment Modifications	8
2.5	Configuration of Tested System	9
3	TEST SET-UP PHOTOS -----	10
4	RF POWER OUTPUT -----	13
4.1	Test Specification	13
4.2	Test Procedure	13
4.3	Test Results	13
4.4	Test Equipment Used; RF Power Output	66
5	OCCUPIED BANDWIDTH -----	67
5.1	Test Specification	67
5.2	Test Procedure	67
5.3	Test Limit	67
5.4	Test Results	67
5.5	Test Equipment Used; Occupied Bandwidth	172
6	SPURIOUS EMISSIONS AT ANTENNA TERMINALS -----	173
6.1	Test Specification	173
6.2	Test Procedure	173
6.3	Test Limit	173
6.4	Test Results	173
6.5	Test Equipment Used; Spurious Emissions at Antenna Terminals	262
7	SPURIOUS RADIATED EMISSION -----	263
7.1	Test Specification	263
7.2	Test Procedure	263
7.3	Test Limit	264
7.4	Test Results	264
7.5	Test Instrumentation Used; Radiated Measurements	265
8	APPENDIX A - CORRECTION FACTORS -----	266
8.1	Correction factors for RF OATS Cable 35m	266
8.2	Correction factors for RF OATS Cable 10m	267
8.3	Correction factors for Horn Antenna	268
8.4	Correction factors for Horn Antenna	269
8.5	Correction factors for Log Periodic Antenna	270
8.6	Correction factors for Biconical Antenna	271
8.7	Correction factors for ACTIVE LOOP ANTENNA	272
8.8	Correction Factors for Horn Antenna Model	273



1 General Information

1.1 Administrative Information

Manufacturer:	Corning Optical Communication Wireless
Manufacturer's Address:	8253 1st Street Vienna, VA 22812 U.S.A. Tel: +1-703 855-1773
Manufacturer's Representative:	Isaac Nissan
Equipment Under Test (E.U.T):	ONE - Optical Network Evolution Wireless Platform
Equipment Model No.:	RAU-5 Remote Antenna Unit
Equipment Serial No.:	Not Designated
Date of Receipt of E.U.T:	September 1, 2020
Start of Test:	September 1, 2020
End of Test:	November 12, 2020
Test Laboratory Location:	I.T.L (Product Testing) Ltd. 1 Batsheva St, Lod, Israel, 7116002
Test Specifications:	FCC Parts 2; 24



1.2 List of Accreditations

The EMC laboratory of I.T.L. is accredited by/registered with the following bodies:

1. The American Association for Laboratory Accreditation (A2LA) (U.S.A.), Certificate No. 1152.01.
2. The Federal Communications Commission (FCC) (U.S.A.), FCC Designation Number is IL1005.
3. The Israel Ministry of the Environment (Israel), Registration No. 1104/01.
4. The Voluntary Control Council for Interference by Information Technology Equipment (VCCI) (Japan), Registration Numbers: C-20025, R-2729, T-20028, G-20068.
5. Department of Innovation, Science and Economic Development (ISED) Canada, CAB identifier: IL1002.

I.T.L. Product Testing Ltd. is accredited by the American Association for Laboratory Accreditation (A2LA) and the results shown in this test report have been determined in accordance with I.T.L.'s terms of accreditation unless stated otherwise in the report.



1.3 Product Description

Modular 7 band Enabled Mid Power Neutral Host Solution –
Supported modular frequency bands

700, ESMR+CELL, PCS, AWS, WCS

Integrated 2.5 GHz expansion ready

Composite Output Power

AWS: 34dBm

PCS, WCS: 33dBm

700, ESMR & CELL: 30dBm

Specifications

100% Modularity

NEBS Class 2 Compliant

Small Footprint – 6 Rack Units

Highlights:

Extended ONE platform design Diversity

100% modular component design

Composite output power: 2W

Small Compact Form Factor (6U)

Non-Service Impacting Upgrades

Lower initial deployment costs

1.4 Test Methodology

Both conducted and radiated testing were performed according to the procedures in KDB 935210 D05 v01r03 April 2019 and ANSI/TIA-603-E-2016. Radiated testing was performed at an antenna to EUT distance of 3 meters.

1.5 Test Facility

Both conducted and radiated emissions tests were performed at I.T.L.'s testing facility in Lod, Israel. I.T.L.'s EMC Laboratory is accredited by A2LA, certificate No. 1152.01. Its FCC Designation Number is IL1005 and its ISED CAB identifier: IL1002.



1.6 Measurement Uncertainty

Conducted Emission

Conducted Emission (CISPR 11, EN 55011, CISPR 32, EN 55032, ANSI C63.4)

0.15 – 30 MHz:

Expanded Uncertainty (95% Confidence, K=2):

± 3.44 dB

Radiated Emission

Radiated Emission (CISPR 11, EN 55011, CISPR 22, EN 55022, ANSI C63.4)

for open site:

30-1000MHz:

Expanded Uncertainty (95% Confidence, K=2):

± 4.96 dB

1 GHz to 6 GHz

Expanded Uncertainty (95% Confidence, K=2):

±5.19 dB

>6 GHz

Expanded Uncertainty (95% Confidence, K=2):

±5.51 dB



2 System Test Configuration

2.1 *Justification*

1. The E.U.T was originally FCC certified on 12/26/2014 under FCC ID: OJF1RAU5. It originally supported cellular 3G & 4G technology.
2. A C2PC Grant was issued on 01/05/2017 allowing E.U.T. to operate as part of a booster system with the RXU2325 certified under FCC ID: OJF1RXUN.
3. Currently the manufacturer has made the following C2PC changes:
Enabling the use of 5G technology via software changes only with the same operation bands. No changes have been made to the hardware.
4. The following tests were performed: RF Output Power, Occupied Bandwidth and Spurious Emissions.
5. The EUT meets the requirements of a C2PC.

2.2 *EUT Exercise Software*

The Element Management System SW Version 3.7 build 50 used for commands delivery. These SW are used to enable/disable the EUT transmission.

2.3 *Special Accessories*

No special accessories were needed in order to achieve compliance.

2.4 *Equipment Modifications*

No modifications were necessary in order to achieve compliance.

2.5 Configuration of Tested System

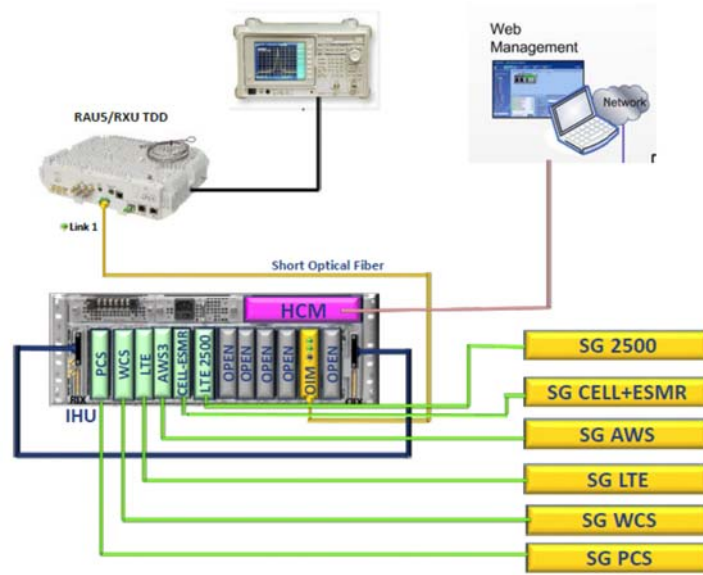

Figure 1. Conducted Test Set-Up

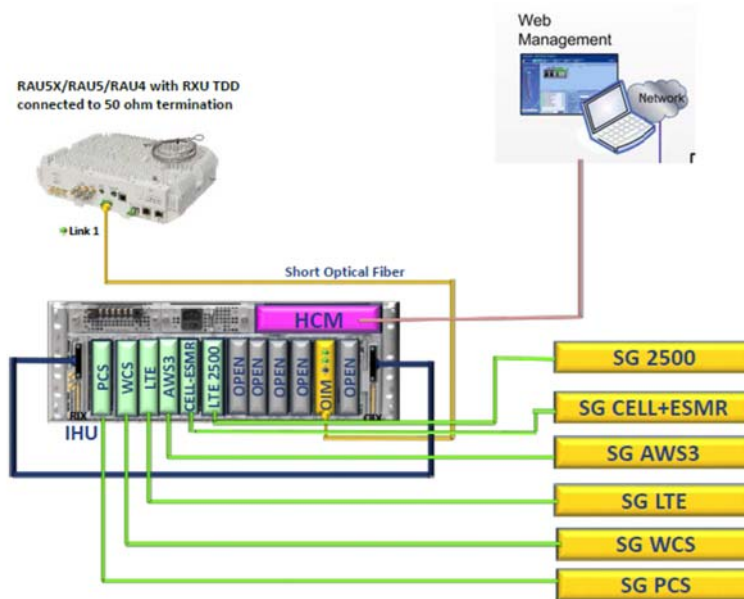

Figure 2. Radiated Test Set-Up

3 Test Set-Up Photos



Figure 3. Conducted Emission From Antenna Port Tests

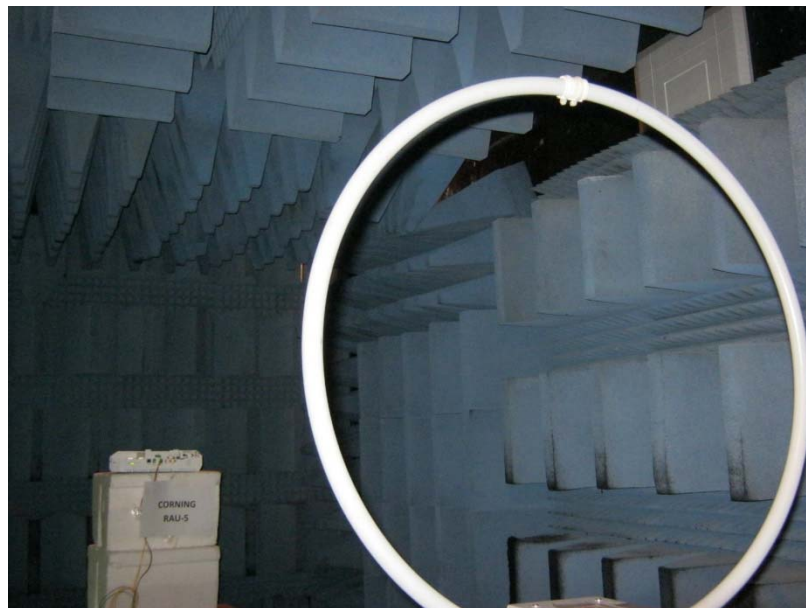

Figure 4. Radiated Emission Test 0.009MHz-30MHz



Figure 5. Radiated Emission Test 30 - 200 MHz



Figure 6. Radiated Emission Test 200 - 1000MHz



Figure 7. Radiated Emission Test 1-18GHz

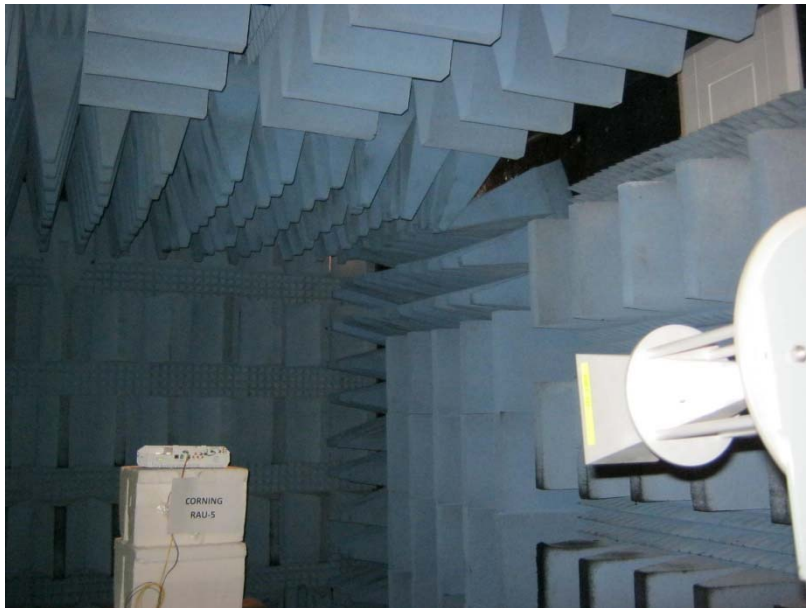

Figure 8. Radiated Emission Test 18-20.0GHz



4 RF Power Output

4.1 Test Specification

Parts 24; Subpart E

4.2 Test Procedure

(Temperature (22°C)/ Humidity (60%RH))

The E.U.T. antenna terminal was connected to the Spectrum Analyzer through an external attenuator and an appropriate coaxial cable (41.0 dB). Special attention was taken to prevent Spectrum Analyzer RF input overload.

4.3 Test Results

JUDGEMENT: Passed

See additional information in *Table 1* to *Table 8* and *Figure 9* to *Figure 272*.



Modulation	Bandwidth (MHz)	Sub Carrier (kHz)	Operation Frequency (MHz)	Reading (dBm)	
16QAM	5	15	1932.5	20.67	
		30	1932.5	20.87	
		15	1962.5	19.35	
		30	1962.5	19.23	
		15	1992.5	19.77	
		30	1992.5	19.61	
	10	15	1935.0	20.22	
			30	1935.0	20.19
			60	1935.0	20.81
		30	1962.5	18.47	
			1962.5	19.98	
			1962.5	19.11	
		60	1990.0	20.27	
			1990.0	20.13	
			1990.0	19.80	
	15	15	1937.5	20.22	
			30	1937.5	19.58
			60	1937.5	20.20
		30	1962.5	19.14	
			1962.5	20.03	
			1962.5	19.07	
		60	1987.5	19.53	
			1987.5	20.43	
			1987.5	20.40	
	20	15	1940.0	19.19	
			30	1940.0	19.77
			60	1940.0	20.07
		30	1962.5	17.54	
			1962.5	20.43	
			1962.5	19.08	
		60	1985.0	18.18	
			1985.0	19.96	
			1985.0	20.30	
	25	15	1942.5	20.32	
			30	1942.5	20.23
			60	1942.5	20.26
		30	1962.5	19.69	
			1962.5	19.72	
			1962.5	19.81	
		60	1982.5	19.89	
			1982.5	19.81	
			1982.5	19.93	

Table 1 RF Power Output 16QAM



Modulation	Bandwidth (MHz)	Sub Carrier (kHz)	Operation Frequency (MHz)	Reading (dBm)
16QAM	40	15	1950.0	18.15
		30	1950.0	19.15
		60	1950.0	20.77
		15	1962.5	17.09
		30	1962.5	19.59
		60	1962.5	20.29
		15	1975.0	17.03
		30	1975.0	20.33
		60	1975.0	20.61
	50	15	1955.0	20.32
		30	1955.0	20.42
		60	1955.0	20.33
		15	1962.5	19.83
		30	1962.5	19.89
		60	1962.5	19.86
		15	1970.0	19.58
		30	1970.0	20.45
		60	1970.0	19.50
	60	30	1960.0	19.58
		60	1960.0	19.79
		30	1962.5	20.39
		60	1962.5	20.54
		30	1965.0	20.16
		60	1965.0	20.27

Table 2 RF Power Output 16QAM



Modulation	Bandwidth (MHz)	Sub Carrier (kHz)	Operation Frequency (MHz)	Reading (dBm)	
64QAM	5	15	1932.5	20.03	
		30	1932.5	20.06	
		15	1962.5	19.95	
		30	1962.5	18.44	
		15	1992.5	19.05	
		30	1992.5	19.05	
	10	10	15	1935.0	19.51
			30	1935.0	20.08
			60	1935.0	19.68
			15	1962.5	19.81
			30	1962.5	19.75
			60	1962.5	19.80
			15	1990.0	19.65
			30	1990.0	19.27
			60	1990.0	19.50
	15	15	15	1937.5	19.63
			30	1937.5	19.60
			60	1937.5	19.24
			15	1962.5	19.83
			30	1962.5	18.89
			60	1962.5	20.08
			15	1987.5	19.38
			30	1987.5	19.30
			60	1987.5	19.50
	20	20	15	1940.0	20.17
			30	1940.0	20.01
			60	1940.0	20.07
			15	1962.5	18.74
			30	1962.5	19.17
			60	1962.5	18.82
			15	1985.0	19.96
			30	1985.0	19.79
			60	1985.0	19.51
	25	25	15	1942.5	19.56
			30	1942.5	19.86
			60	1942.5	19.89
			15	1962.5	18.78
			30	1962.5	19.51
			60	1962.5	19.79
			15	1982.5	19.65
			30	1982.5	19.75
			60	1982.5	19.38

Table 3 RF Power Output 64QAM



Modulation	Bandwidth (MHz)	Sub Carrier (kHz)	Operation Frequency (MHz)	Reading (dBm)
64QAM	40	15	1950.0	20.08
		30	1950.0	18.72
		60	1950.0	19.58
		15	1962.5	19.18
		30	1962.5	19.22
		60	1962.5	18.53
		15	1975.0	19.13
		30	1975.0	18.74
		60	1975.0	18.13
	50	15	1955.0	18.74
		30	1955.0	18.78
		60	1955.0	18.68
		15	1962.5	18.69
		30	1962.5	17.98
		60	1962.5	18.58
		15	1970.0	18.26
		30	1970.0	18.35
		60	1970.0	18.18
	60	30	1960.0	18.91
		60	1960.0	18.96
		30	1962.5	18.87
		60	1962.5	18.95
		30	1965.0	18.74
		60	1965.0	18.55

Table 4 RF Power Output 64QAM



Modulation	Bandwidth (MHz)	Sub Carrier (kHz)	Operation Frequency (MHz)	Reading (dBm)	
256QAM	5	15	1932.5	18.35	
		30	1932.5	19.38	
		15	1962.5	17.96	
		30	1962.5	19.27	
		15	1992.5	18.40	
		30	1992.5	19.67	
	10	10	15	1935.0	19.94
			30	1935.0	20.02
			60	1935.0	19.93
			15	1962.5	18.20
			30	1962.5	19.17
			60	1962.5	17.53
			15	1990.0	18.91
			30	1990.0	18.76
			60	1990.0	18.95
	15	15	15	1937.5	19.75
			30	1937.5	19.31
			60	1937.5	19.49
			15	1962.5	18.21
			30	1962.5	19.02
			60	1962.5	17.93
			15	1987.5	19.80
			30	1987.5	19.60
			60	1987.5	18.19
	20	20	15	1940.0	19.23
			30	1940.0	19.92
			60	1940.0	19.94
			15	1962.5	18.05
			30	1962.5	19.22
			60	1962.5	17.73
			15	1985.0	18.16
			30	1985.0	19.36
			60	1985.0	19.90
	25	25	15	1942.5	19.57
			30	1942.5	19.53
			60	1942.5	19.45
			15	1962.5	19.72
			30	1962.5	19.47
			60	1962.5	17.43
			15	1982.5	19.96
			30	1982.5	19.91
			60	1982.5	19.23

Table 5 RF Power Output 256QAM



Modulation	Bandwidth (MHz)	Sub Carrier (kHz)	Operation Frequency (MHz)	Reading (dBm)
256QAM	40	15	1950.0	19.50
		30	1950.0	19.38
		60	1950.0	19.41
		15	1962.5	18.27
		30	1962.5	19.13
		60	1962.5	18.30
		15	1975.0	19.06
		30	1975.0	19.02
		60	1975.0	18.95
	50	15	1955.0	19.29
		30	1955.0	19.95
		60	1955.0	19.82
		15	1962.5	19.97
		30	1962.5	19.56
		60	1962.5	19.37
		15	1970.0	19.29
		30	1970.0	19.60
		60	1970.0	19.16
	60	30	1960.0	20.06
		60	1960.0	19.85
		30	1962.5	20.03
		60	1962.5	19.72
		30	1965.0	19.84
		60	1965.0	19.86

Table 6 RF Power Output 256QAM



Modulation	Bandwidth (MHz)	Sub Carrier (kHz)	Operation Frequency (MHz)	Reading (dBm)	
QPSK	5	15	1932.5	17.56	
		30	1932.5	20.50	
		15	1962.5	17.95	
		30	1962.5	18.29	
		15	1992.5	18.47	
		30	1992.5	20.32	
	10	10	15	1935.0	20.48
			30	1935.0	20.06
			60	1935.0	20.12
			15	1962.5	18.81
			30	1962.5	19.45
			60	1962.5	18.48
			15	1990.0	19.89
			30	1990.0	19.91
			60	1990.0	19.60
	15	15	15	1937.5	20.54
			30	1937.5	20.31
			60	1937.5	20.15
			15	1962.5	19.00
			30	1962.5	19.56
			60	1962.5	18.69
			15	1987.5	20.09
			30	1987.5	20.11
			60	1987.5	19.17
	20	20	15	1940.0	20.36
			30	1940.0	20.10
			60	1940.0	20.22
			15	1962.5	19.21
			30	1962.5	19.91
			60	1962.5	18.13
			15	1985.0	20.05
			30	1985.0	20.06
			60	1985.0	18.42
	25	25	15	1942.5	19.75
			30	1942.5	19.79
			60	1942.5	20.69
15			1962.5	18.80	
30			1962.5	20.43	
60			1962.5	18.93	
15			1982.5	20.71	
30			1982.5	20.73	
60			1982.5	20.26	

Table 7 RF Power Output QPSK



Modulation	Bandwidth (MHz)	Sub Carrier (kHz)	Operation Frequency (MHz)	Reading (dBm)
QPSK	40	15	1950.0	20.15
		30	1950.0	20.53
		60	1950.0	20.40
		15	1962.5	20.08
		30	1962.5	20.15
		60	1962.5	20.36
		15	1975.0	20.02
		30	1975.0	19.94
		60	1975.0	20.32
	50	15	1955.0	19.87
		30	1955.0	19.70
		60	1955.0	20.28
		15	1962.5	19.87
		30	1962.5	19.70
		60	1962.5	20.28
		15	1970.0	19.55
		30	1970.0	20.50
		60	1970.0	20.00
	60	30	1960.0	19.85
		60	1960.0	19.79
		30	1962.5	19.69
		60	1962.5	19.69
		30	1965.0	19.54
		60	1965.0	19.46

Table 8 RF Power Output QPSK

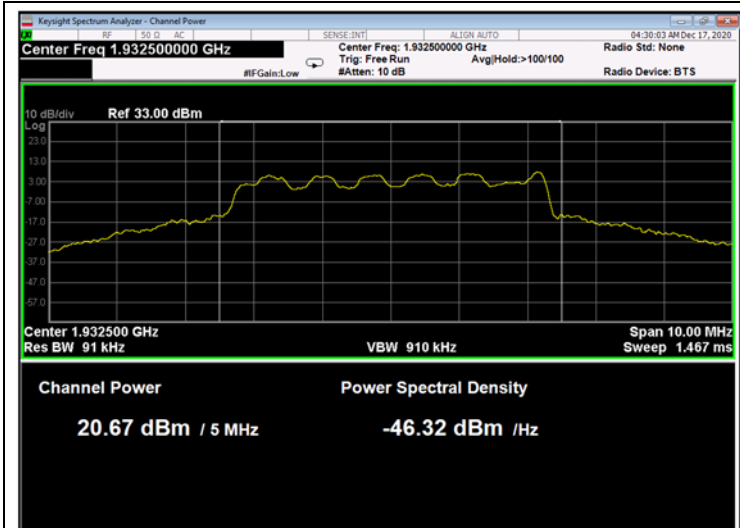

Figure 9: 16QAM 5MHz B.W.; 1932.5MHz, 15kHz

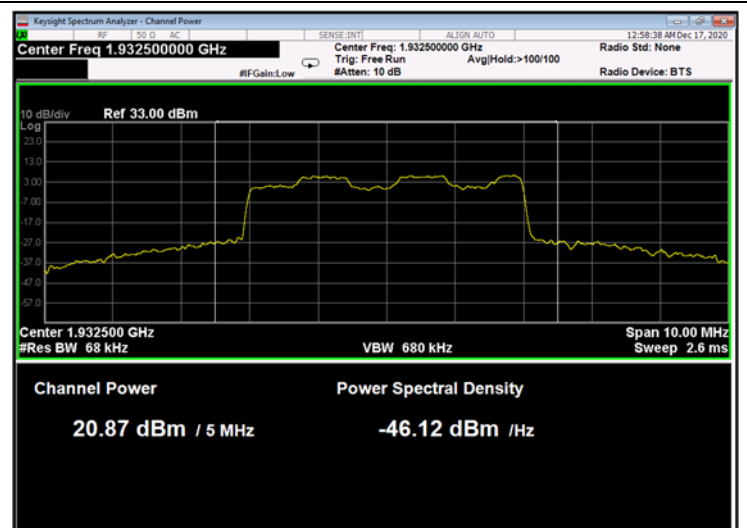

Figure 10: 16QAM 5MHz B.W.; 1932.5MHz, 30kHz

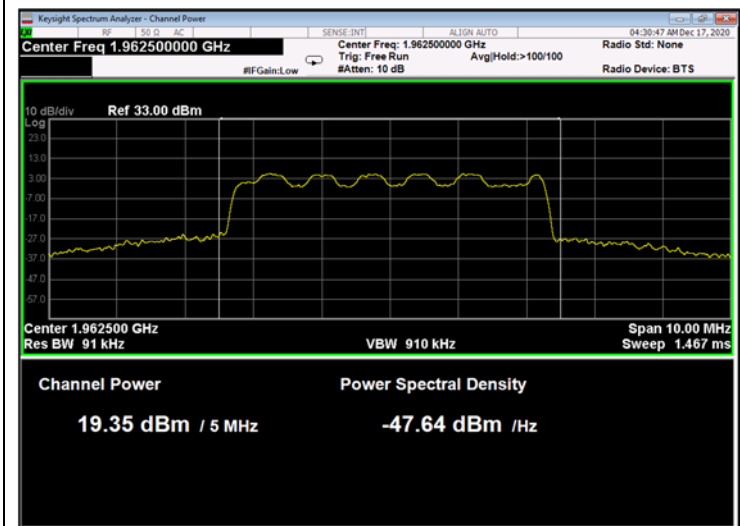

Figure 11: 16QAM 5MHz B.W.; 1962.5MHz, 15kHz

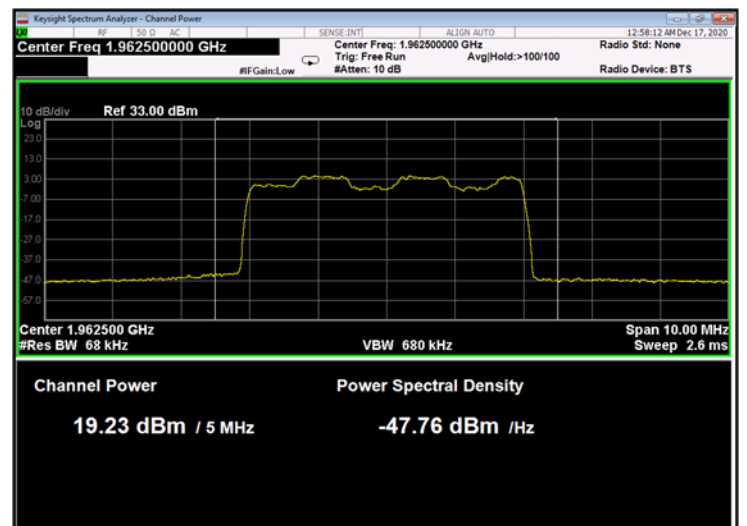

Figure 12: 16QAM 5MHz B.W.; 1962.5MHz, 30kHz

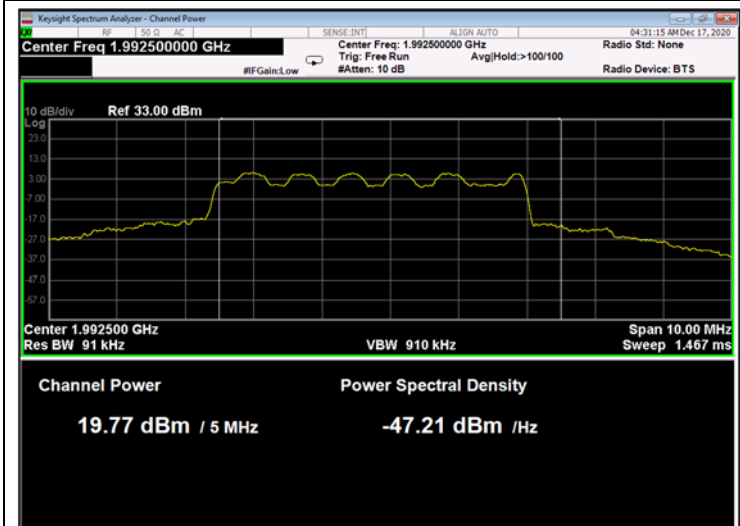

Figure 13: 16QAM 5MHz B.W.; 1992.5MHz, 15kHz

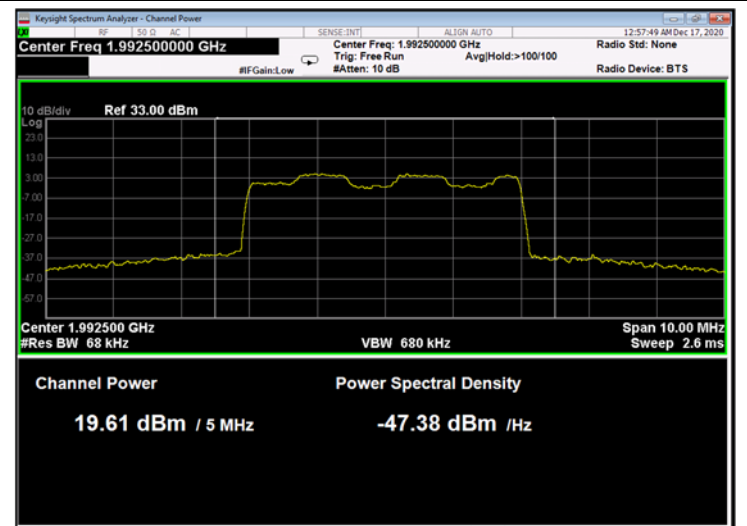

Figure 14: 16QAM 5MHz C.S.; 1992.5MHz, 30kHz

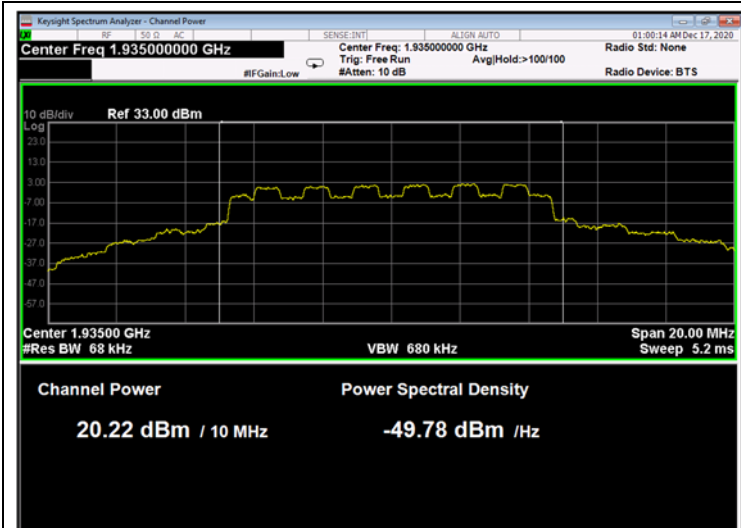

Figure 15: 16QAM 10MHz B.W.; 1935.00MHz, 15kHz

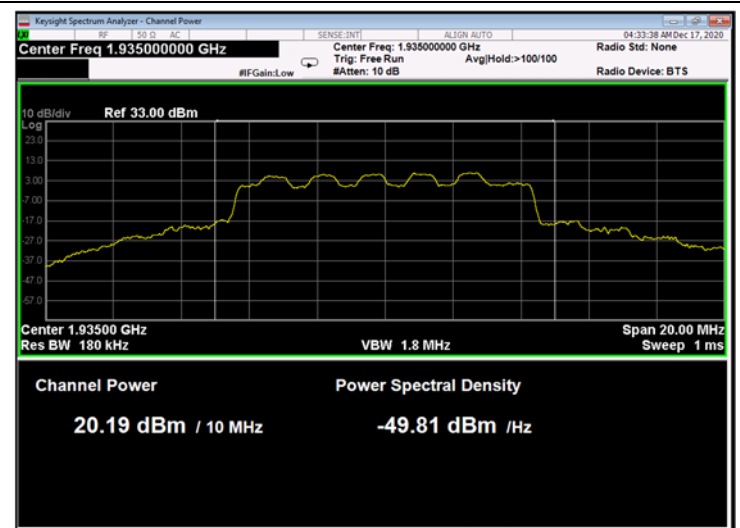

Figure 16: 16QAM 10MHz B.W.; 1935.0MHz, 30kHz

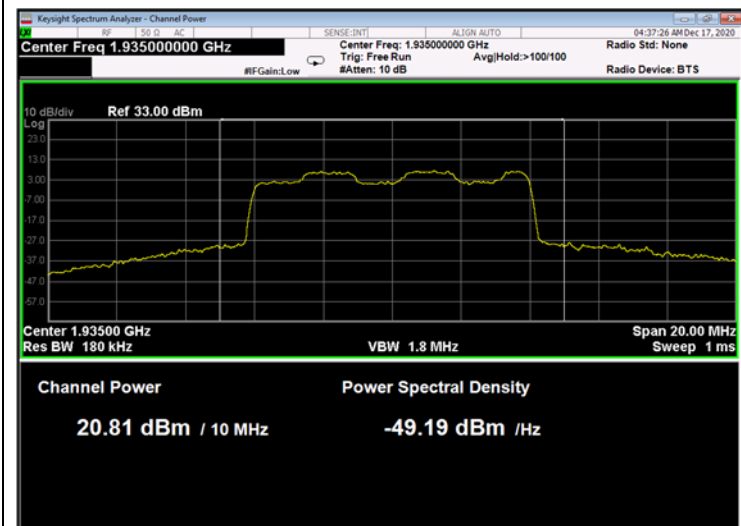

Figure 17: 16QAM 10MHz B.W.; 1935.0MHz, 60kHz

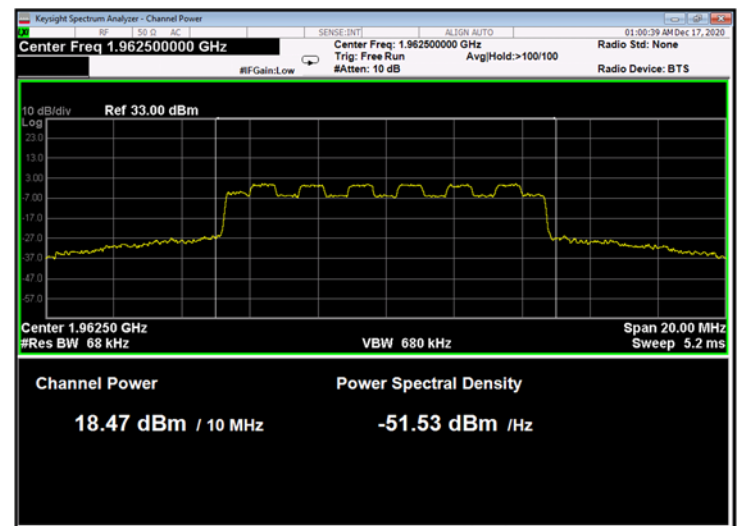

Figure 18: 16QAM 10MHz B.W.; 1962.5MHz, 15kHz

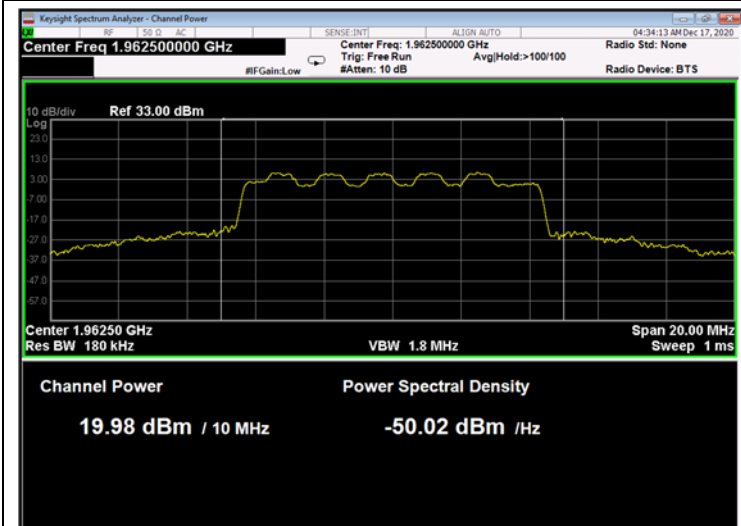

Figure 19: 16QAM 10MHz B.W.; 1962.5MHz, 30kHz

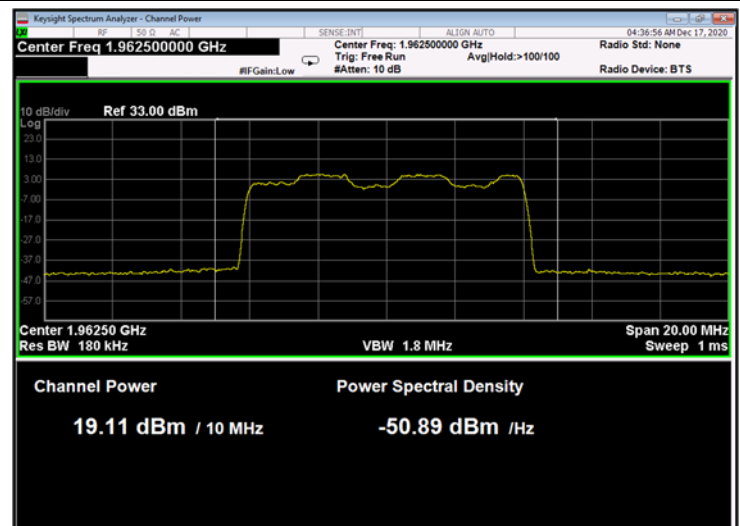

Figure 20: 16QAM 10MHz B.W.; 1962.5MHz, 60kHz

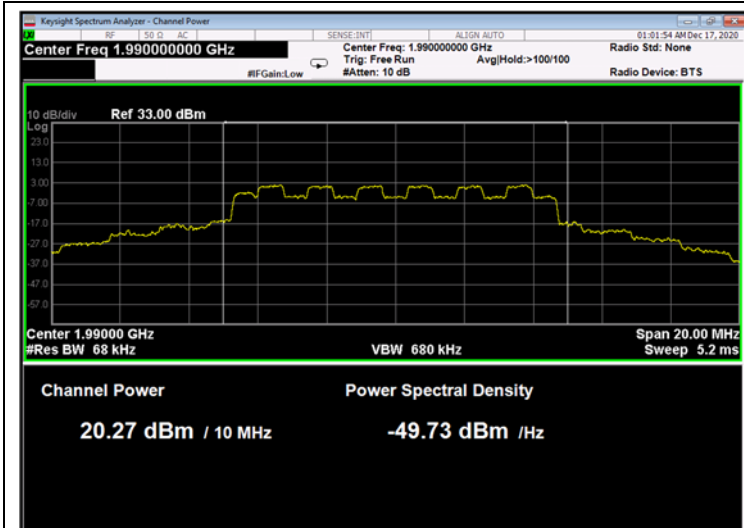

Figure 21: 16QAM 10MHz B.W.; 1990.0MHz, 15kHz

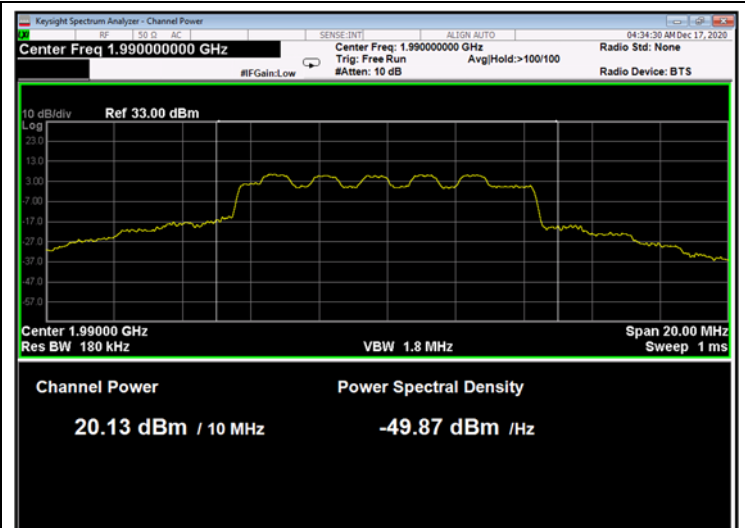

Figure 22: 16QAM 10MHz B.W.; 1990.0MHz, 30kHz

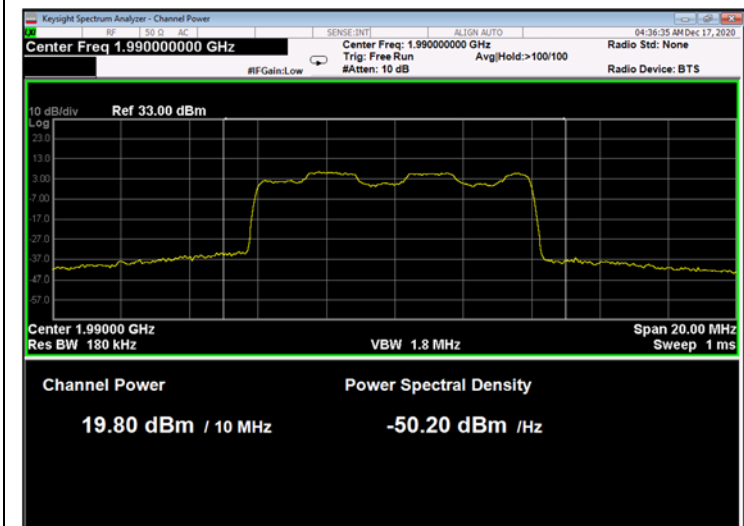

Figure 23: 16QAM 10MHz B.W.; 1990.0MHz, 60kHz

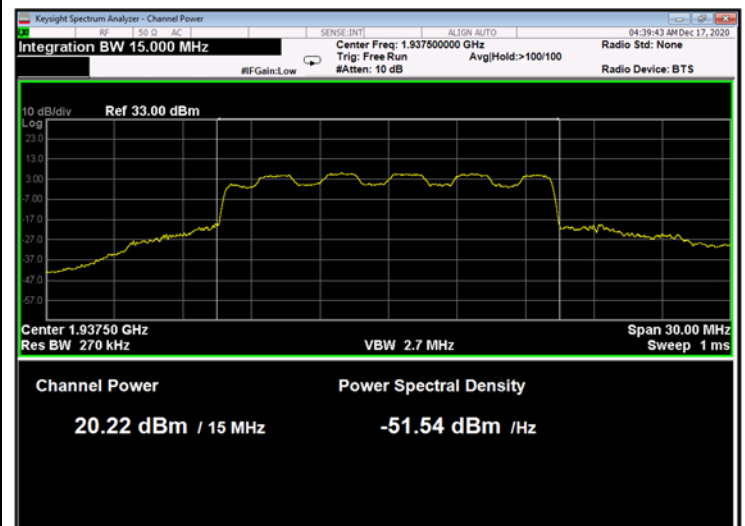

Figure 24: 16QAM 15MHz B.W.; 1937.5MHz, 15kHz

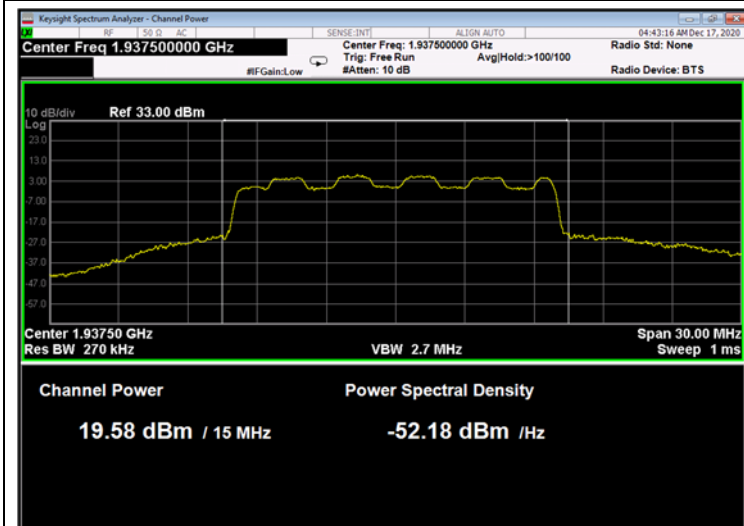

Figure 25: 16QAM 15MHz B.W.; 1937.5MHz, 30kHz

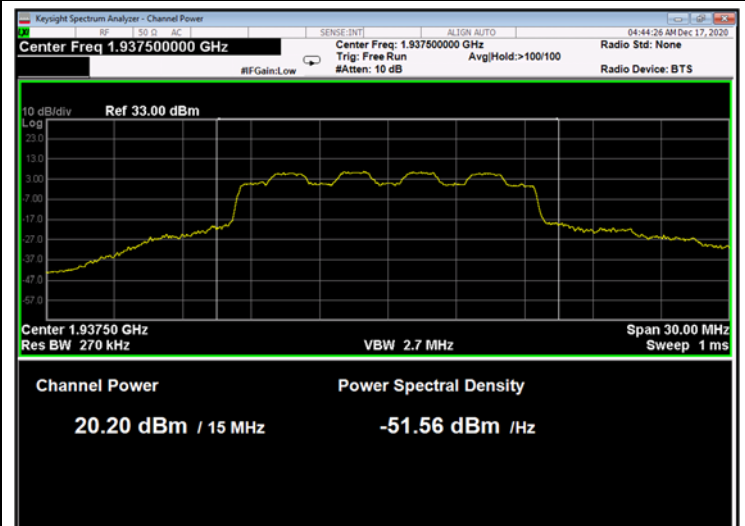

Figure 26: 16QAM 15MHz B.W.; 1937.5MHz, 60kHz

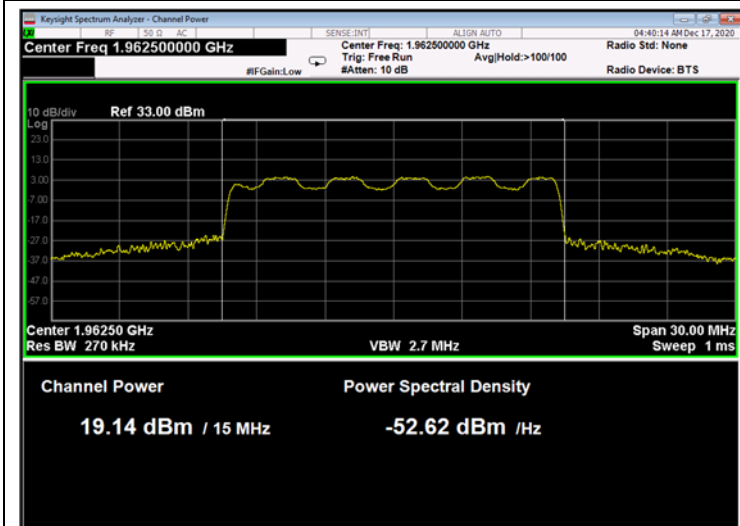

Figure 27: 16QAM 15MHz B.W.; 1962.5MHz, 15kHz

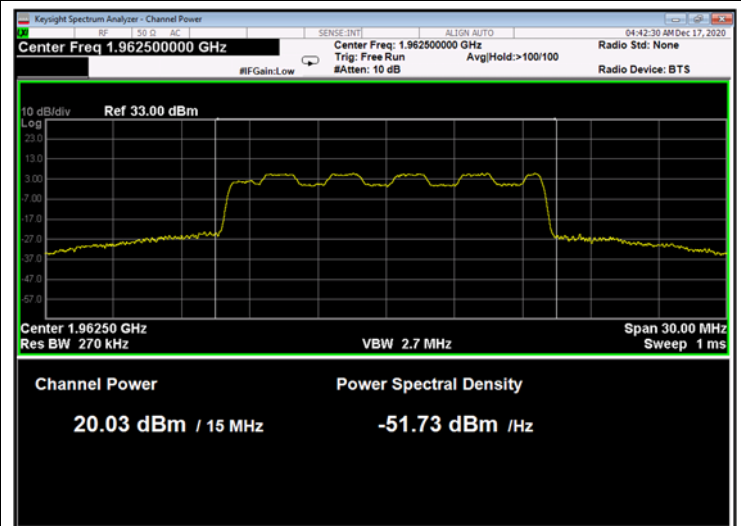

Figure 28: 16QAM 15MHz B.W.; 1962.5MHz, 30kHz

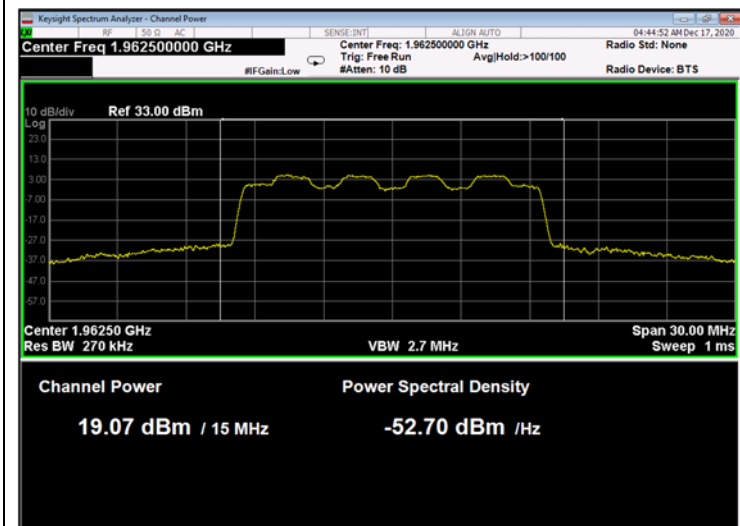

Figure 29: 16QAM 15MHz B.W.; 1962.5MHz, 60kHz

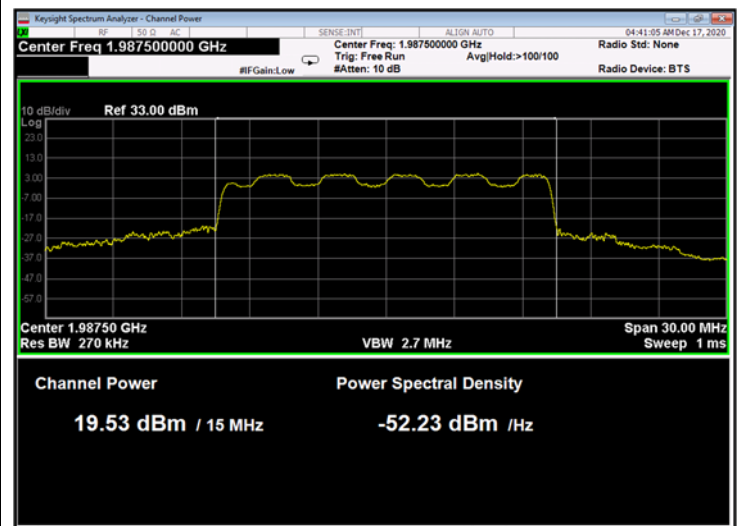

Figure 30: 16QAM 15MHz B.W.; 1987.5MHz, 15kHz

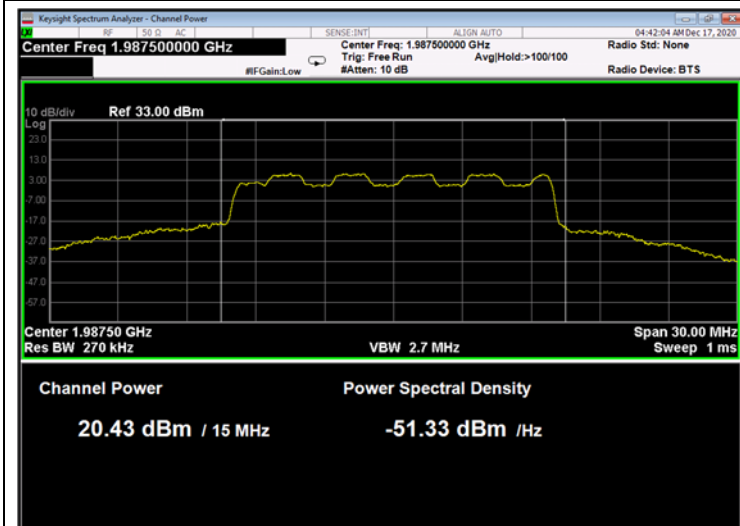

Figure 31: 16QAM 15MHz B.W.; 1987.5MHz, 30kHz

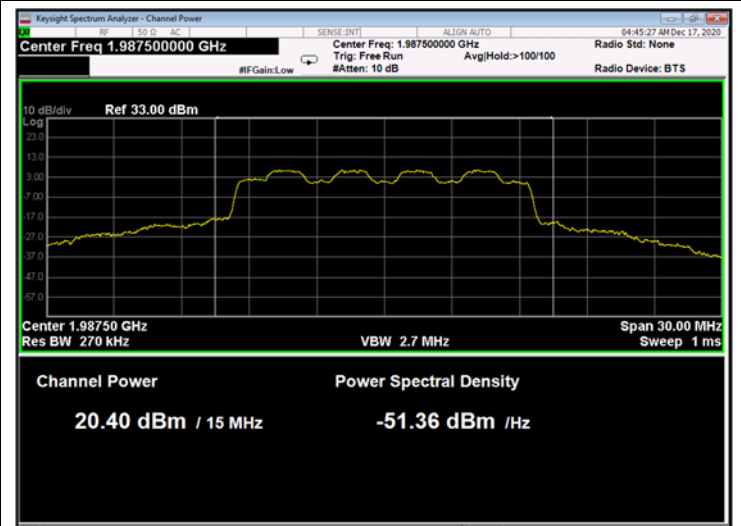

Figure 32: 16QAM 15MHz B.W.; 1987.5MHz, 60kHz

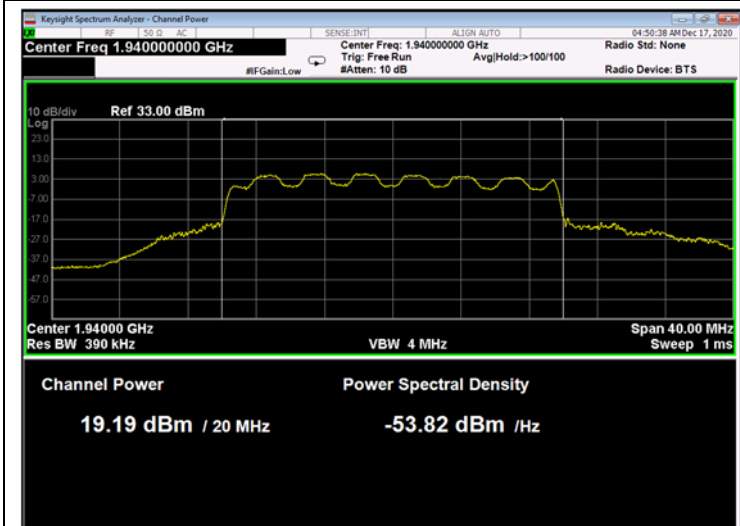

Figure 33: 16QAM 20MHz B.W.; 1940.0MHz, 15kHz

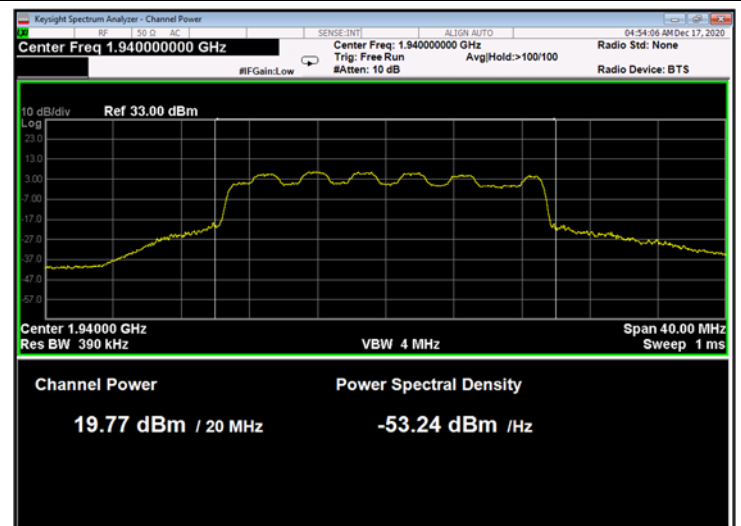

Figure 34: 16QAM 20MHz B.W.; 1940.0MHz, 30kHz

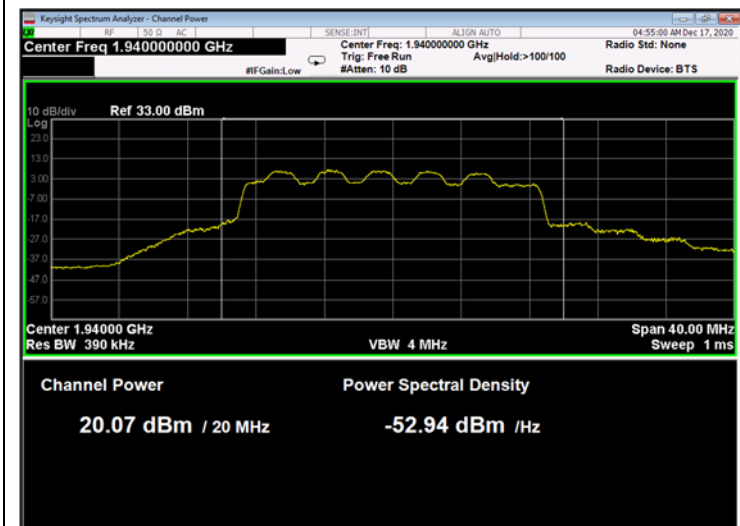

Figure 35: 16QAM 20MHz B.W.; 1940.0MHz, 60kHz

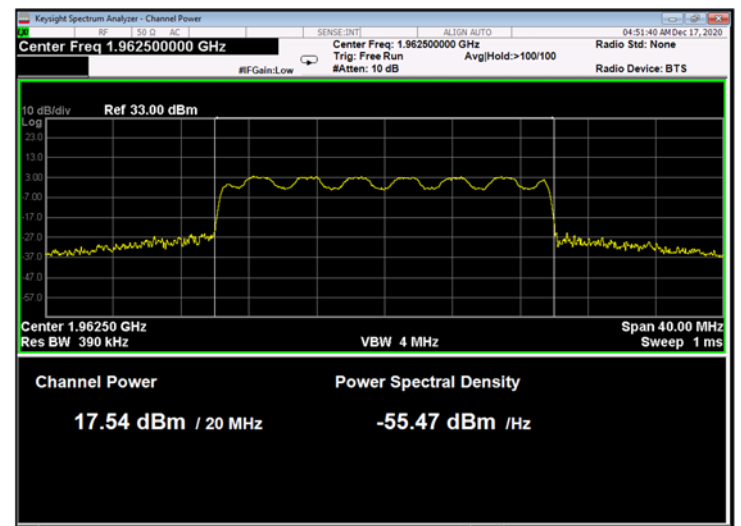

Figure 36: 16QAM 20MHz B.W.; 1962.5MHz, 15kHz

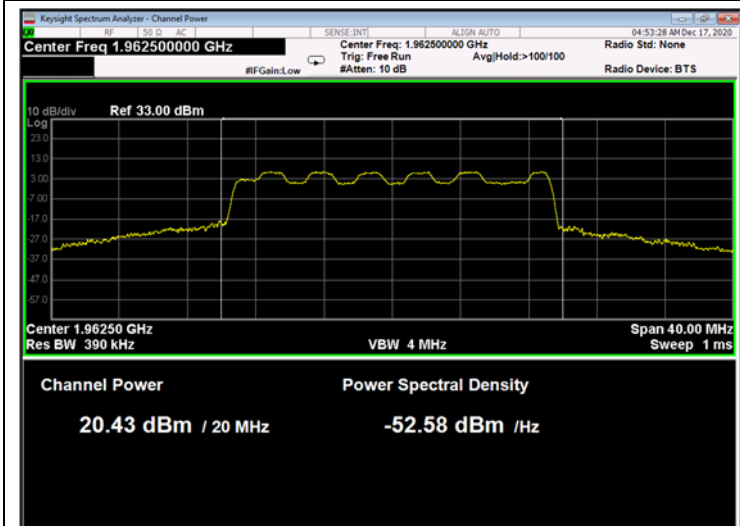

Figure 37: 16QAM 20MHz B.W.; 1962.5MHz, 30kHz

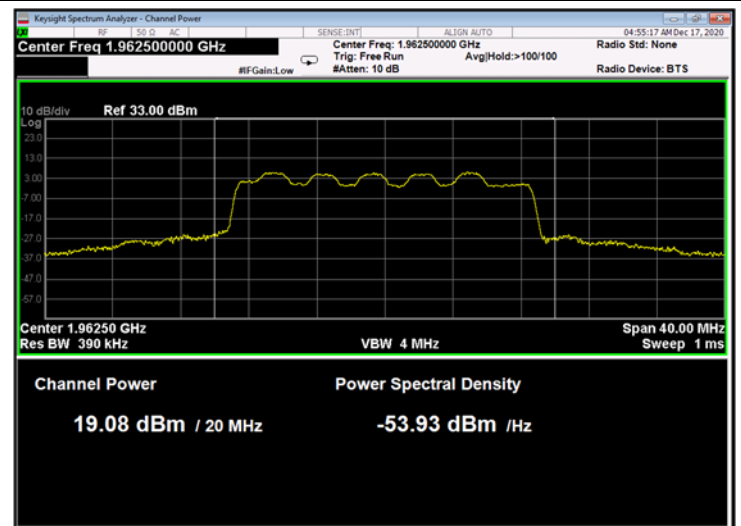

Figure 38: 16QAM 20MHz B.W.; 1962.5MHz, 60kHz

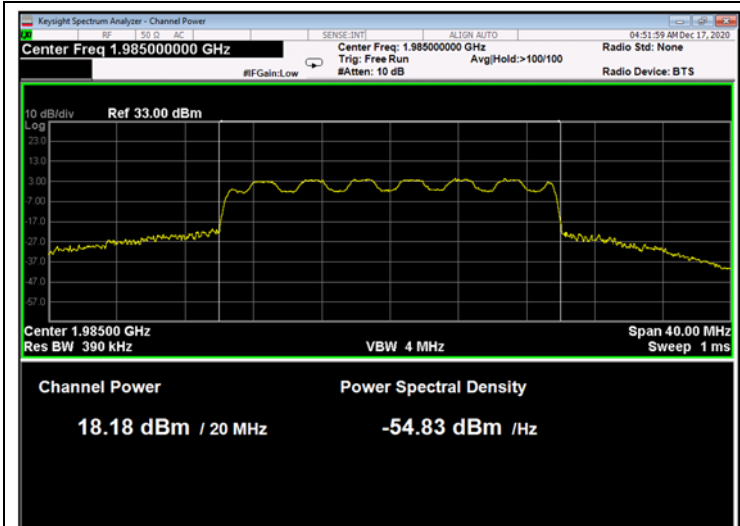

Figure 39: 16QAM 20MHz B.W.; 1985.0MHz, 15kHz

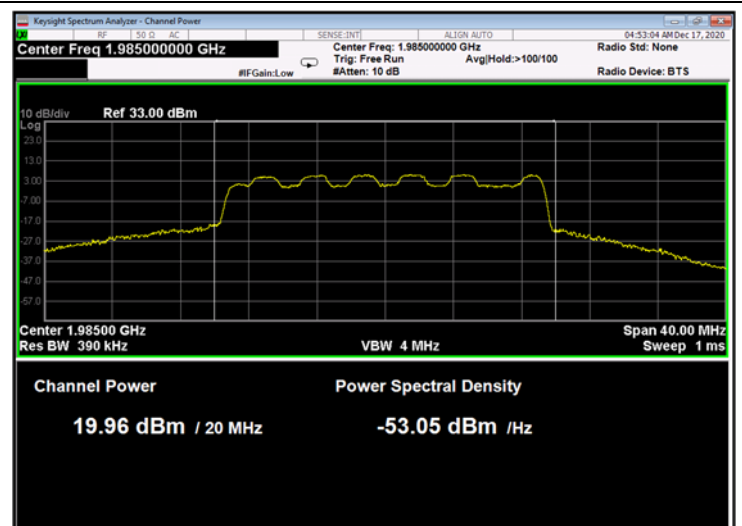

Figure 40: 16QAM 20MHz B.W.; 1985.0MHz, 30kHz

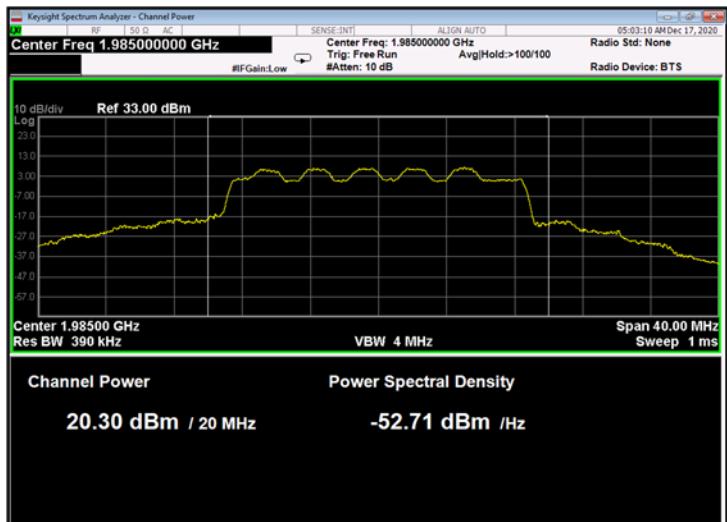

Figure 41: 16QAM 20MHz B.W.; 1985.0MHz, 60kHz

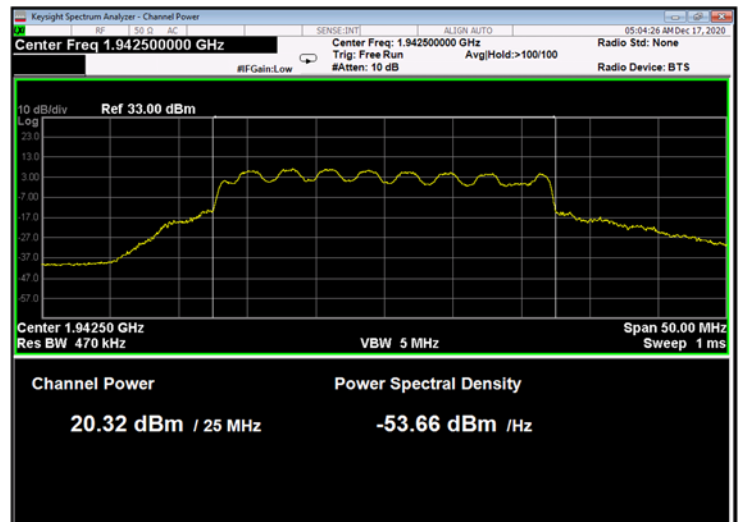

Figure 42: 16QAM 25MHz B.W.; 1942.5MHz, 15kHz

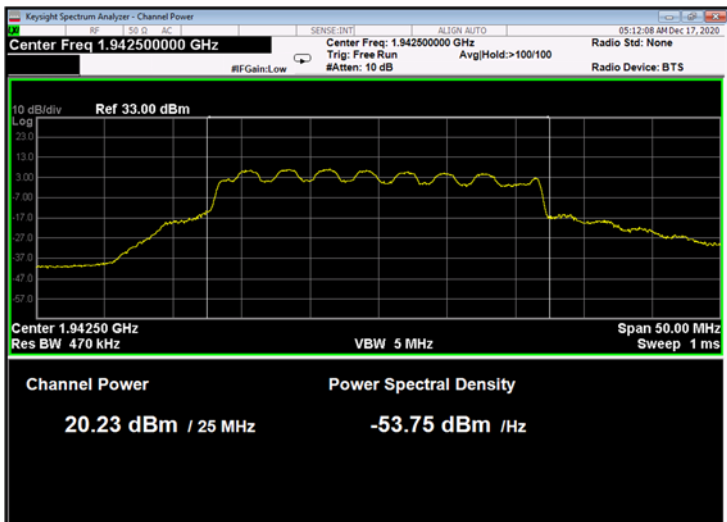

Figure 43: 16QAM 25MHz B.W.; 1942.5MHz, 30kHz

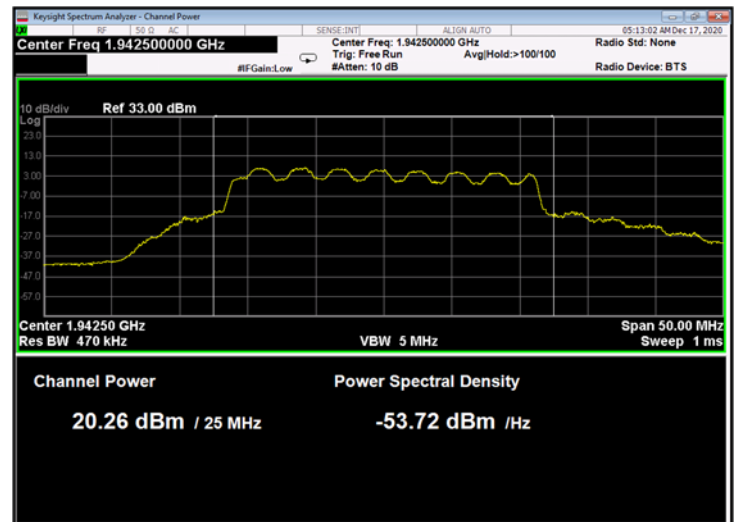

Figure 44: 16QAM 25MHz B.W.; 1942.5MHz, 60kHz

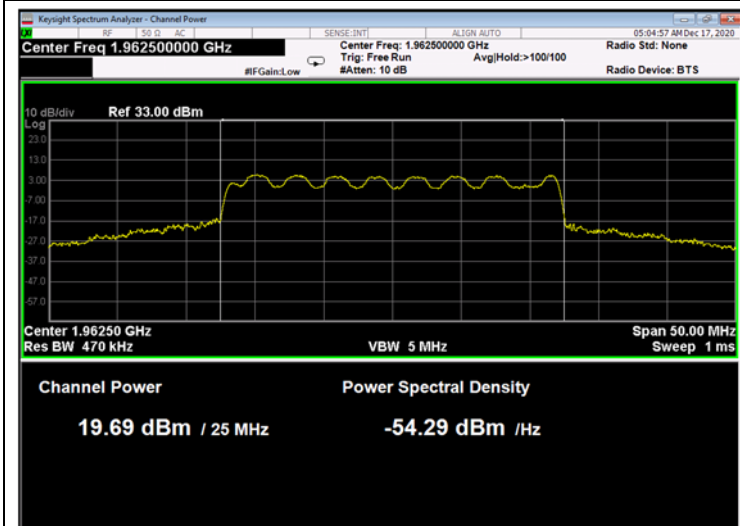

Figure 45: 16QAM 25MHz B.W.; 1962.5MHz, 15kHz

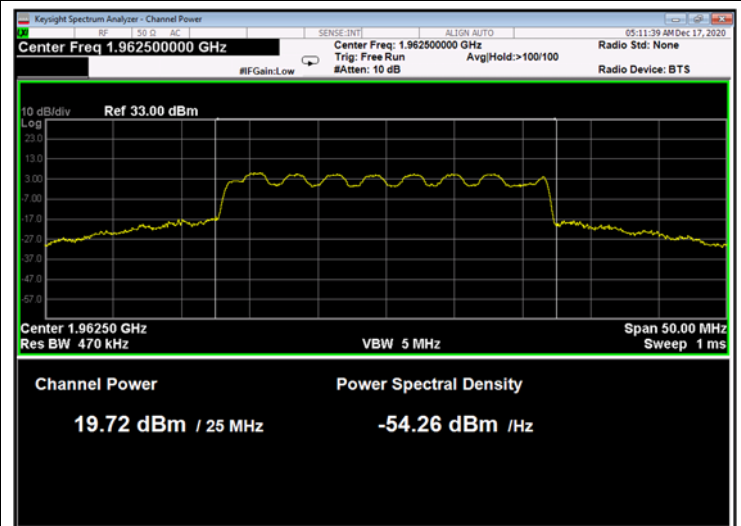

Figure 46: 16QAM 25MHz B.W.; 1962.5MHz, 30kHz

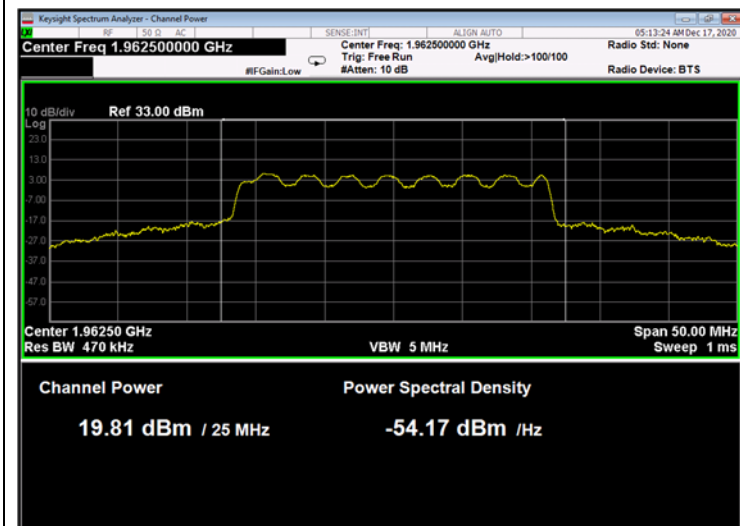

Figure 47: 16QAM 25MHz B.W.; 1962.5MHz, 60kHz

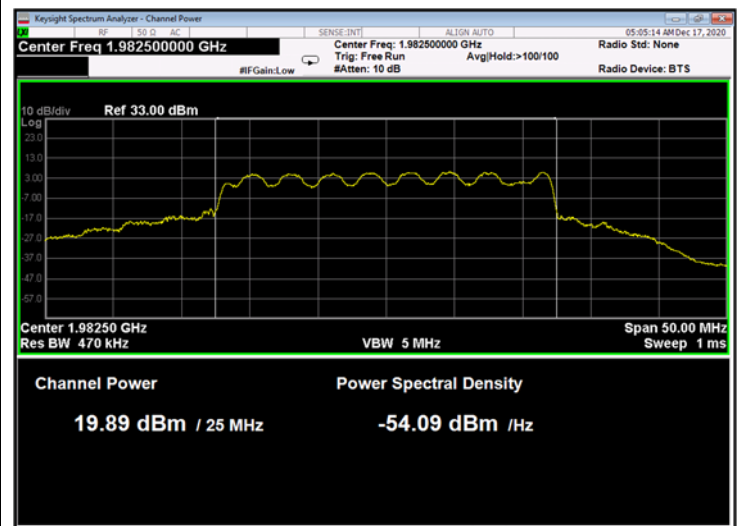

Figure 48: 16QAM 25MHz B.W.; 1982.5MHz, 15kHz

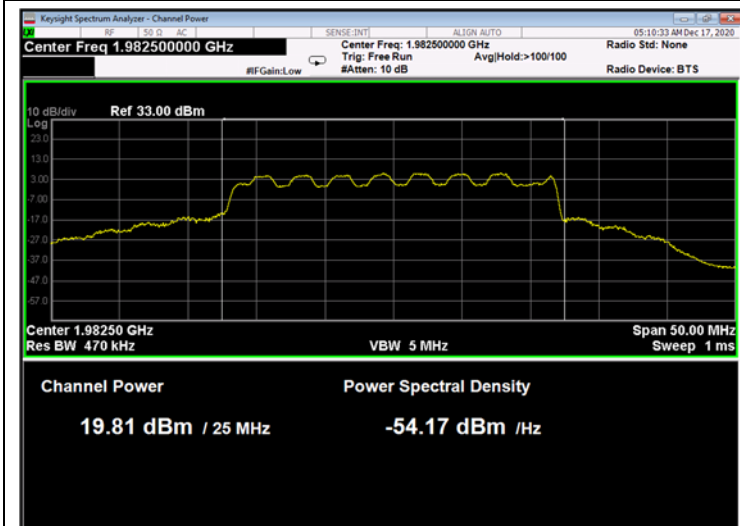

Figure 49: 16QAM 25MHz B.W.; 1982.5MHz, 30kHz

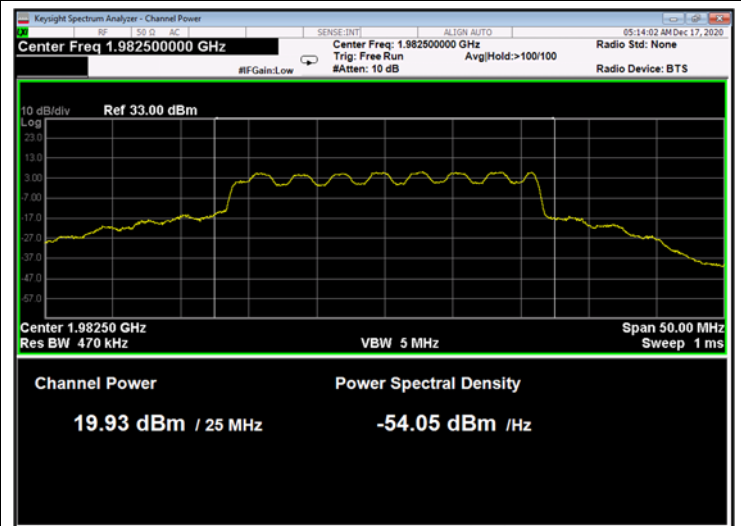

Figure 50: 16QAM 25MHz B.W.; 1982.5MHz, 60kHz

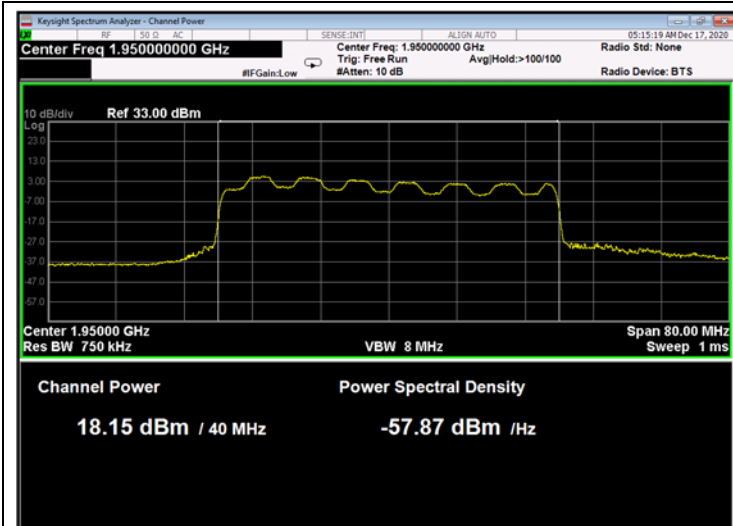

Figure 51: 16QAM 40MHz B.W.; 1950.0MHz, 15kHz

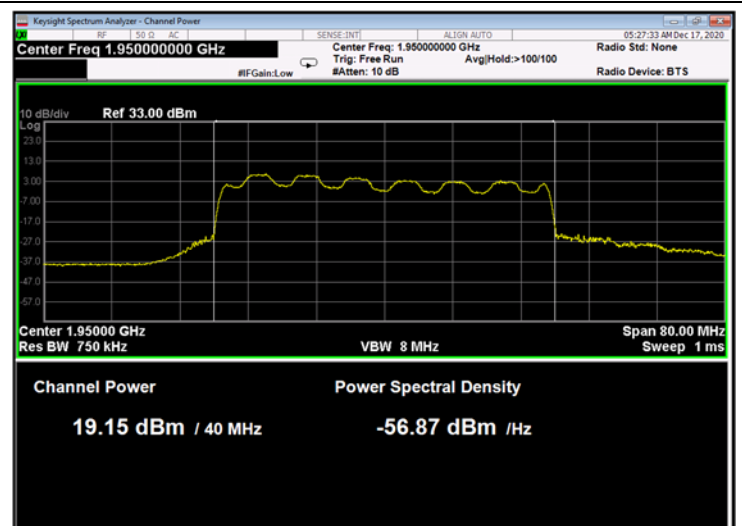

Figure 52: 16QAM 40MHz B.W.; 1950.0MHz, 30kHz

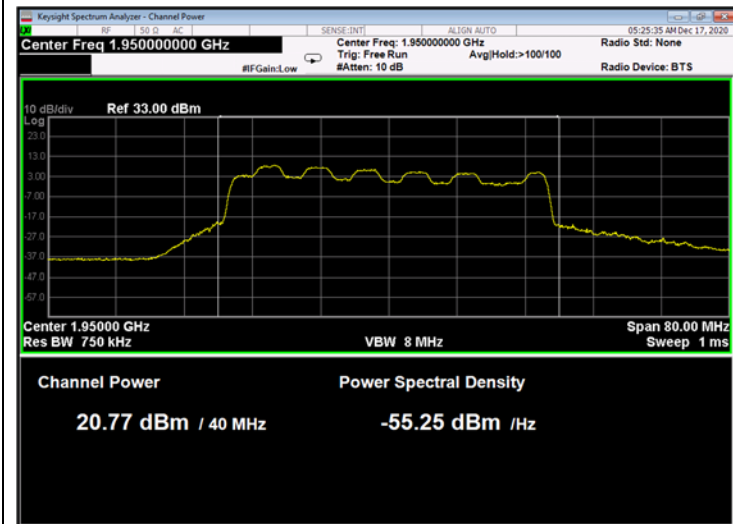

Figure 53: 16QAM 40MHz B.W.; 1950.0MHz, 60kHz

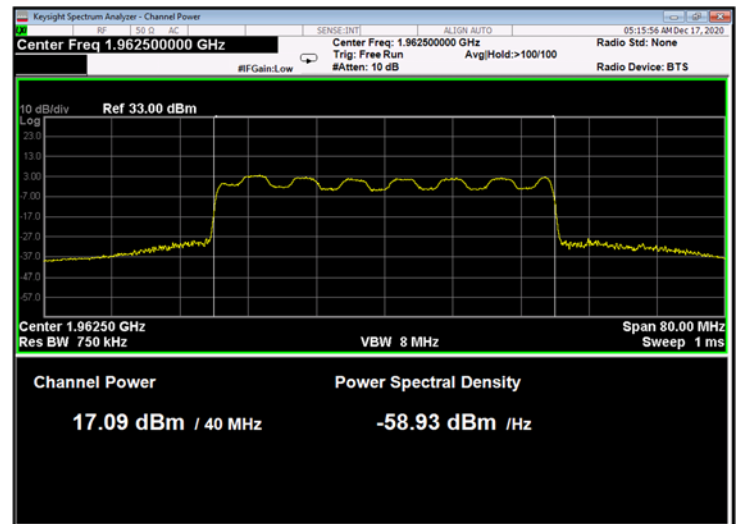

Figure 54: 16QAM 40MHz B.W.; 1962.5MHz, 15kHz

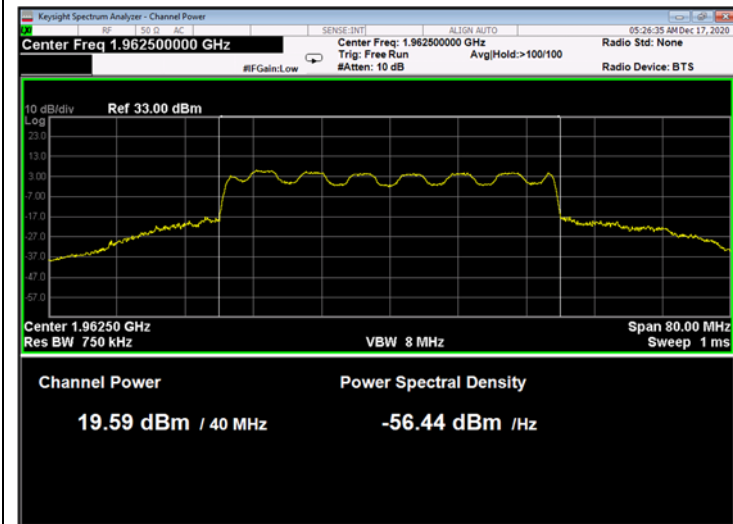

Figure 55: 16QAM 40MHz B.W.; 1962.5MHz, 30kHz

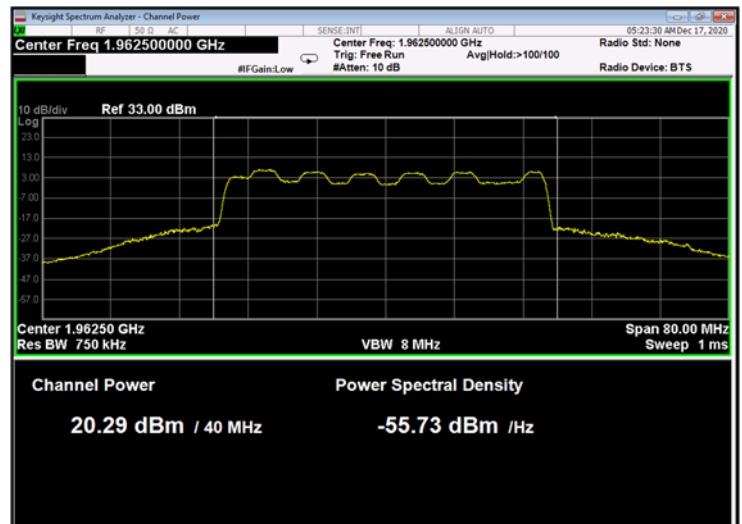

Figure 56: 16QAM 40MHz B.W.; 1962.5MHz, 60kHz

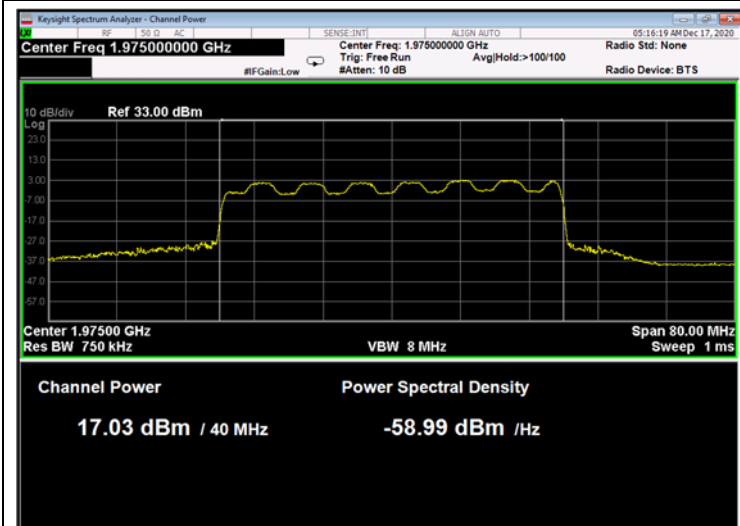

Figure 57: 16QAM 40MHz B.W.; 1975.0MHz, 15kHz

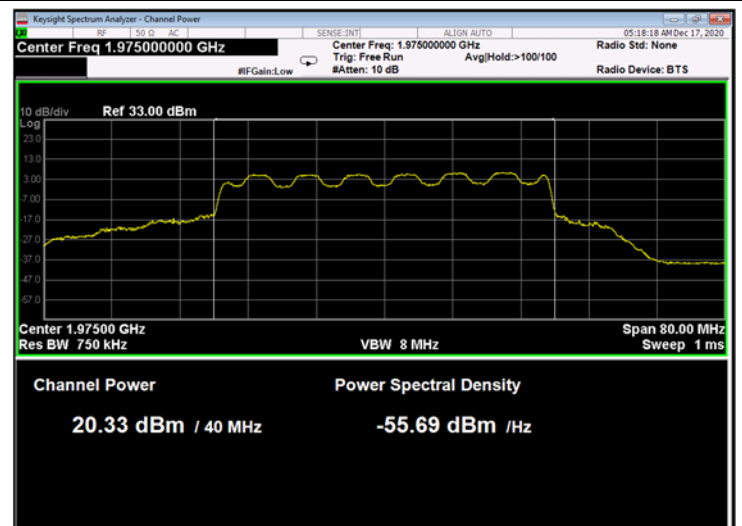

Figure 58: 16QAM 40MHz B.W.; 1975.0MHz, 30kHz

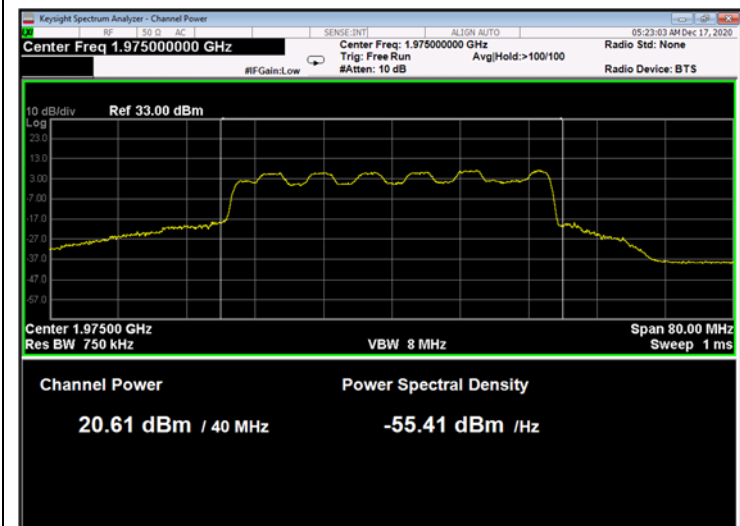

Figure 59: 16QAM 40MHz B.W.; 1975.0MHz, 60kHz

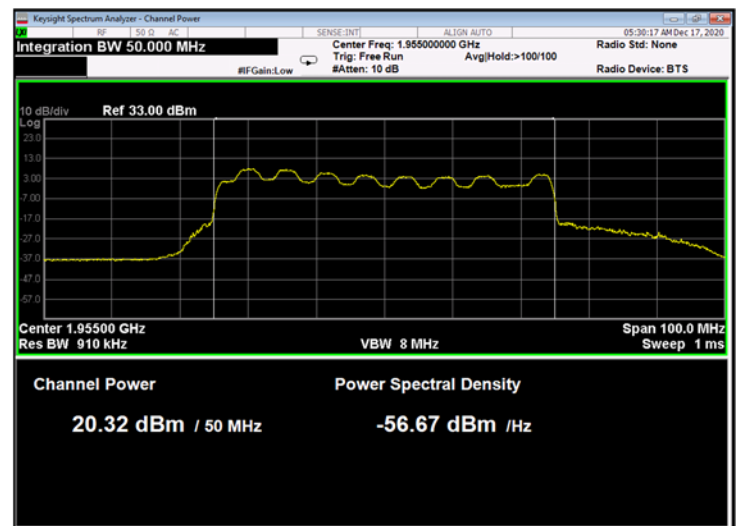

Figure 60: 16QAM 50MHz B.W.; 1955.0MHz, 15kHz

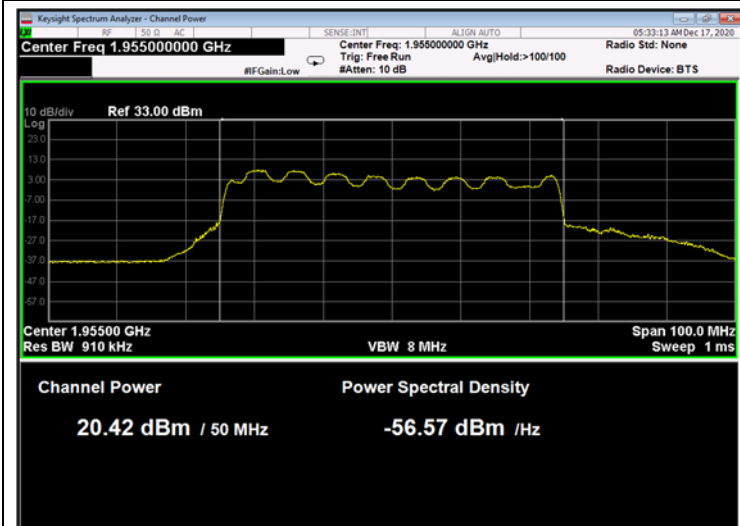

Figure 61: 16QAM 50MHz B.W.; 1955.0MHz, 30kHz

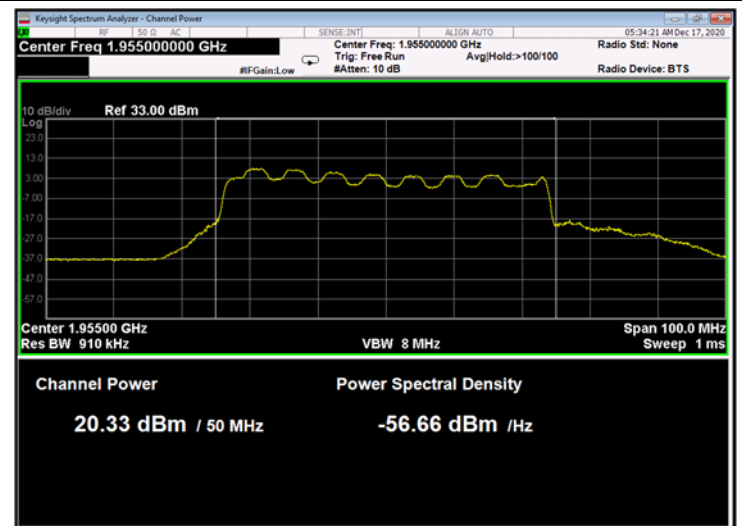

Figure 62: 16QAM 50MHz B.W.; 1955.0MHz, 60kHz

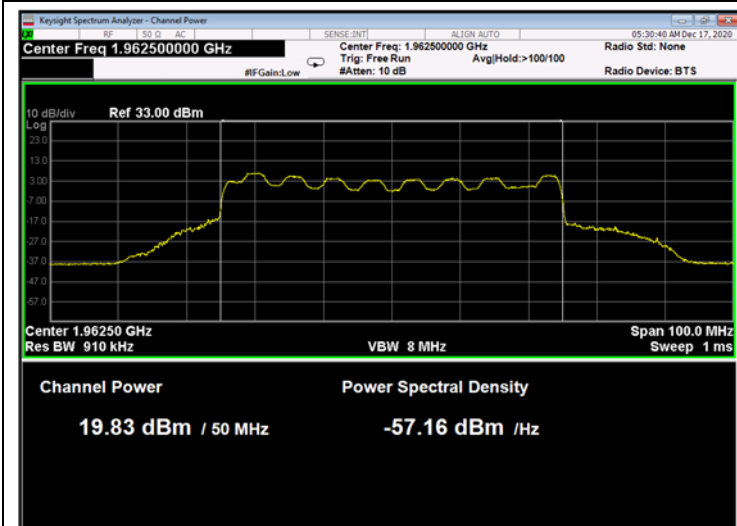

Figure 63: 16QAM 50MHz B.W.; 1962.5MHz, 15kHz

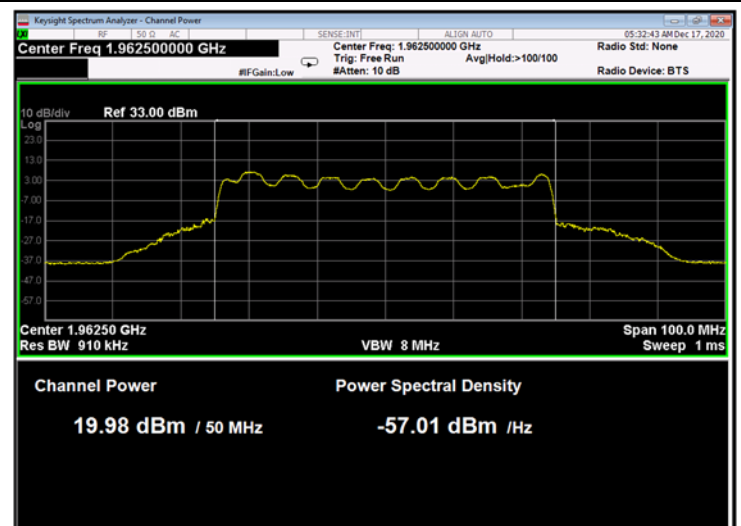

Figure 64: 16QAM 50MHz B.W.; 1962.5MHz, 30kHz

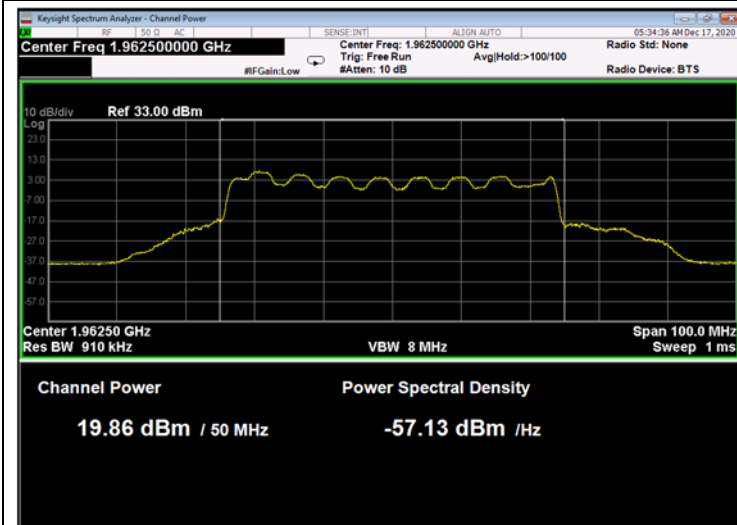

Figure 65: 16QAM 50MHz B.W.; 1962.5MHz, 60kHz

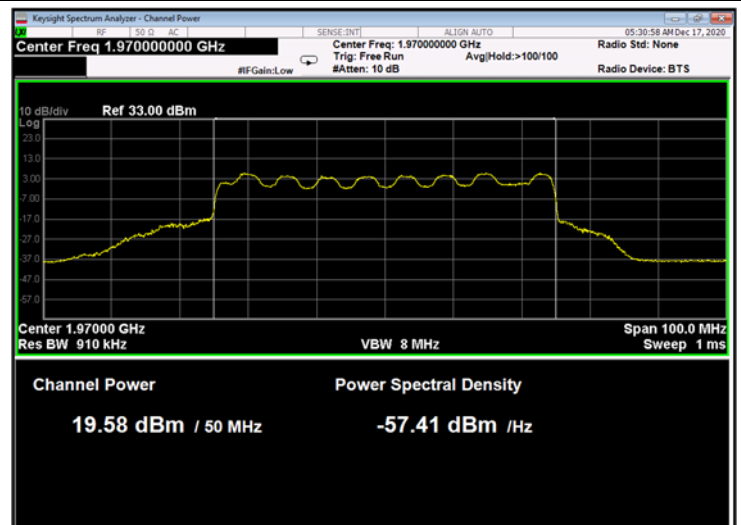

Figure 66: 16QAM 50MHz B.W.; 1970.0MHz, 15kHz

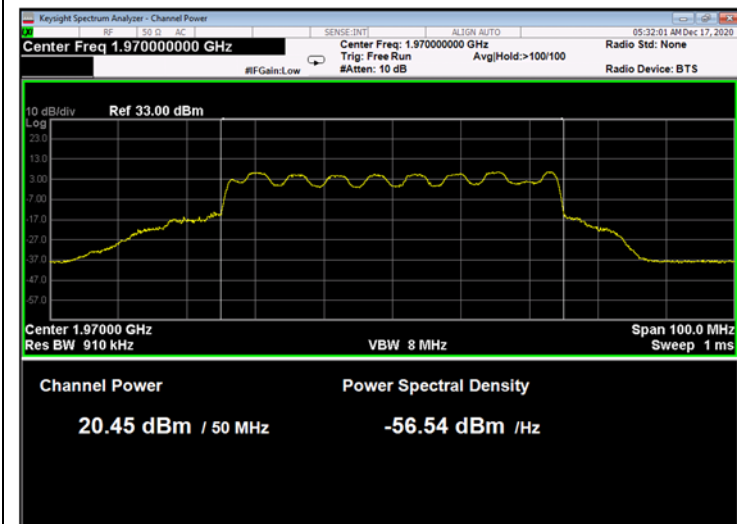

Figure 67: 16QAM 50MHz B.W.; 1970.0MHz, 30kHz

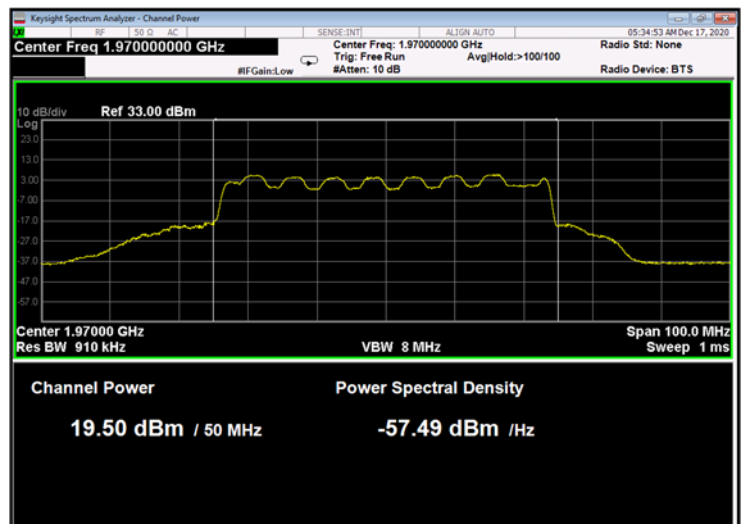

Figure 68: 16QAM 50MHz B.W.; 1970.0MHz, 60kHz

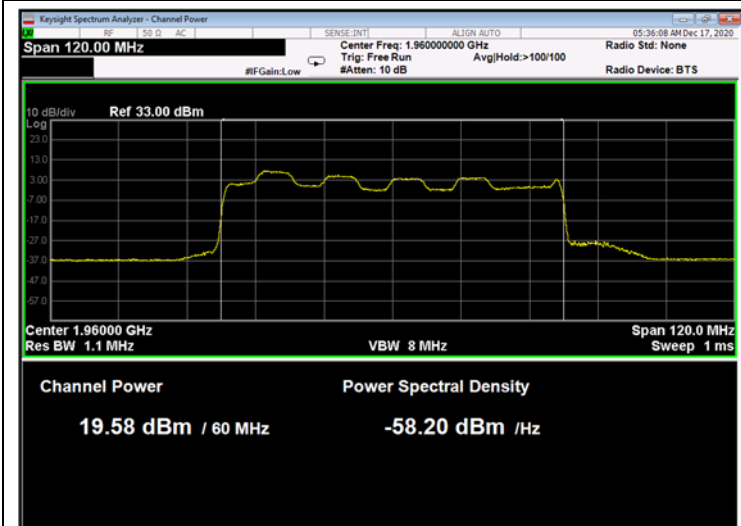

Figure 69: 16QAM 60MHz B.W.; 1960.0MHz, 30kHz

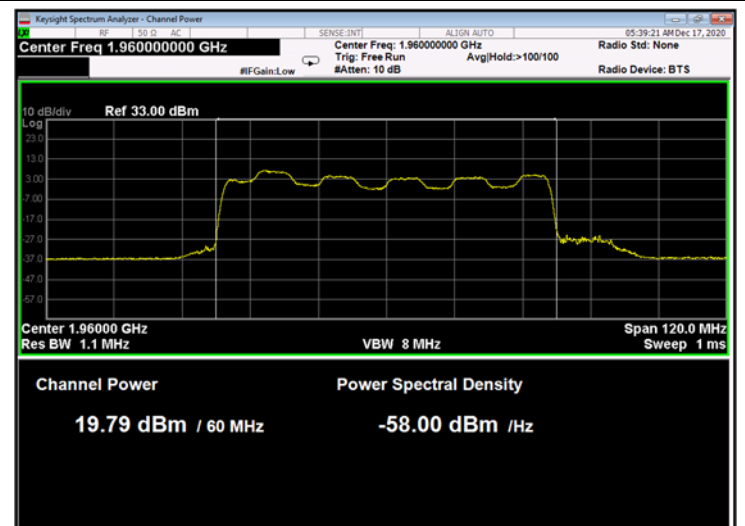

Figure 70: 16QAM 60MHz B.W.; 1960.0MHz, 60kHz

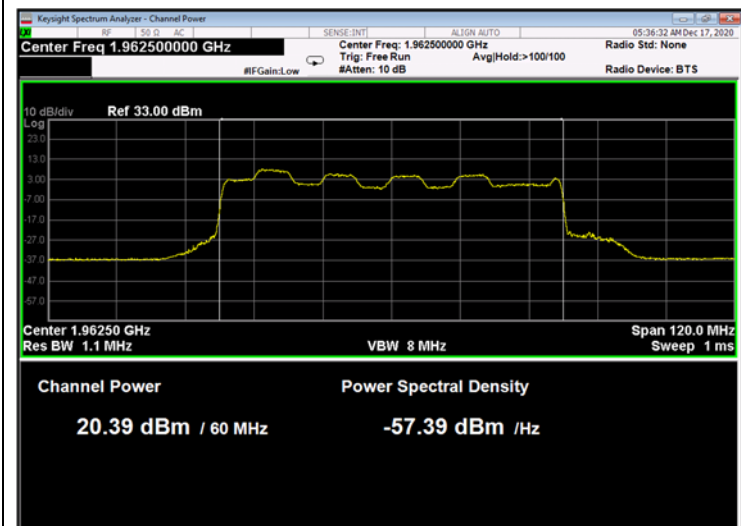

Figure 71: 16QAM 60MHz B.W.; 1962.5MHz, 30kHz

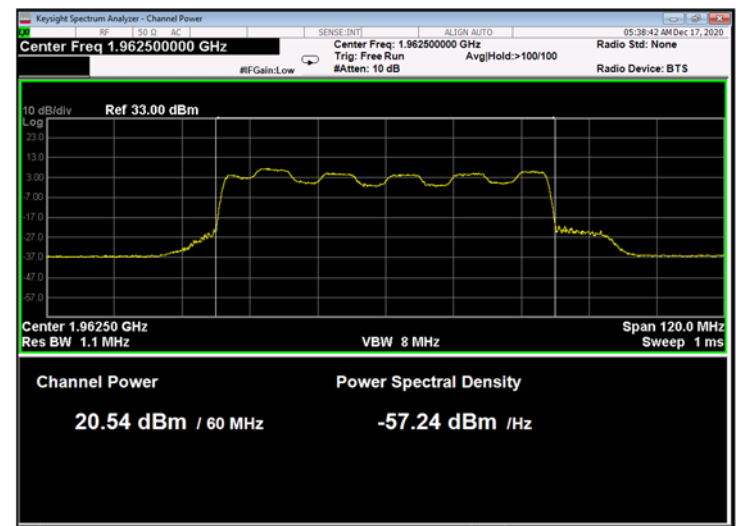

Figure 72: 16QAM 60MHz B.W.; 1962.5MHz, 60kHz

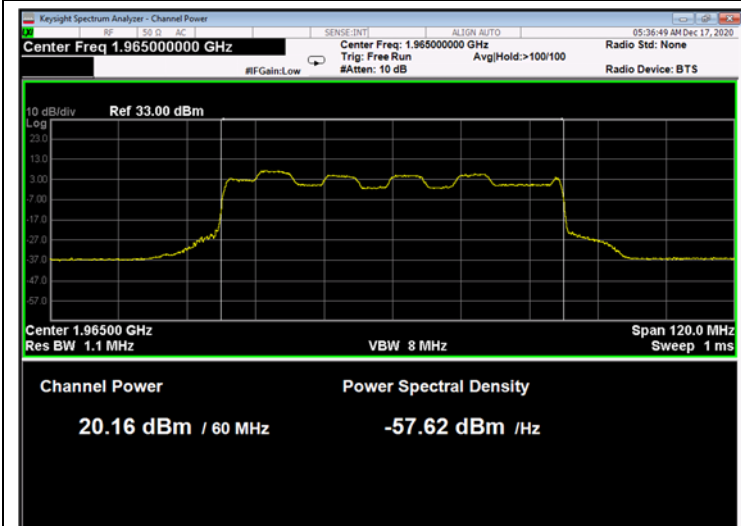

Figure 73: 16QAM 60MHz B.W.; 1965.0MHz, 30kHz

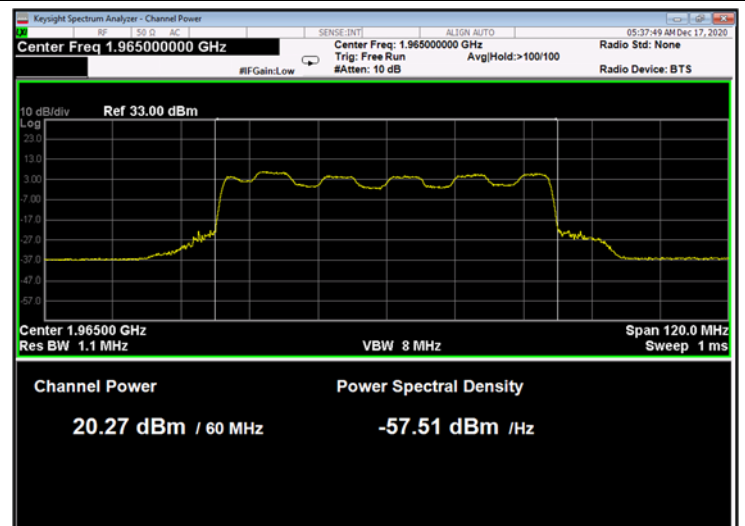

Figure 74: 16QAM 60MHz B.W.; 1965.0MHz, 60kHz

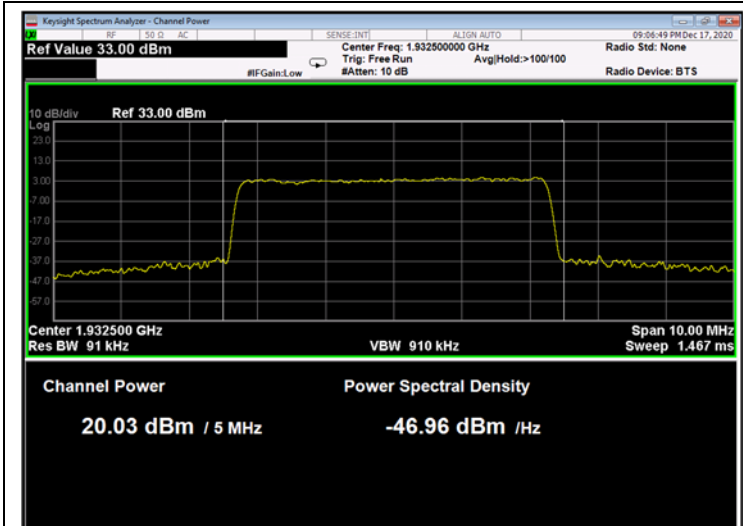

Figure 75: 64QAM 5MHz B.W.; 1932.5MHz, 15kHz

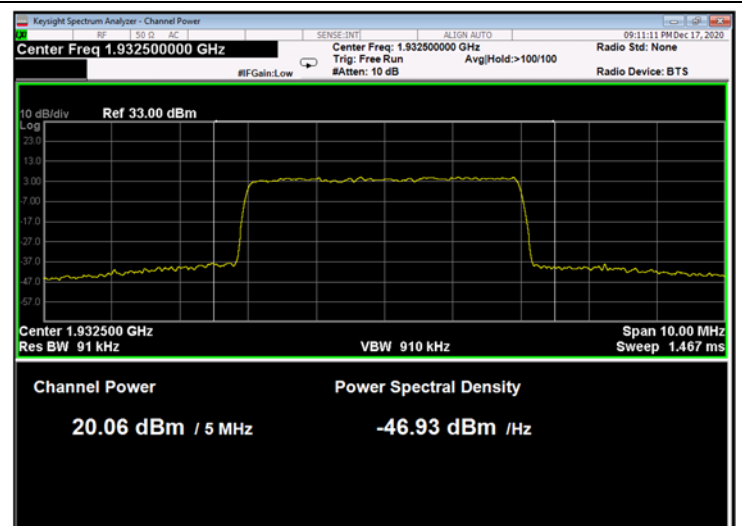

Figure 76: 64QAM 5MHz B.W.; 1932.5MHz, 30kHz

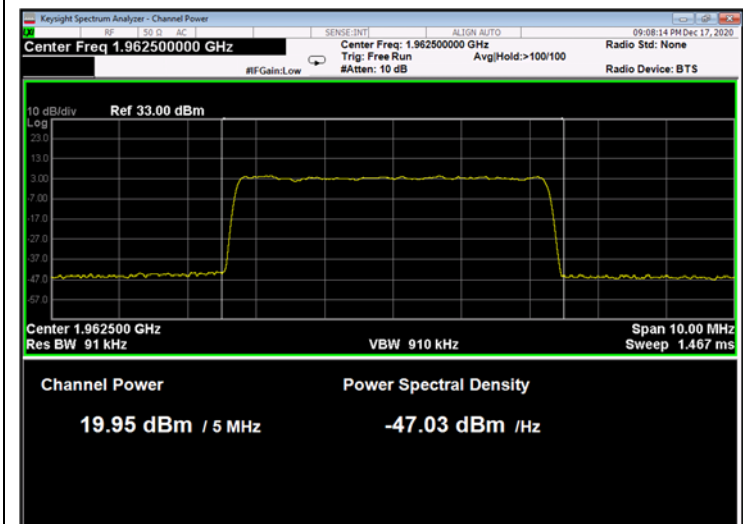

Figure 77: 64QAM 5MHz B.W.; 1962.5MHz, 15kHz

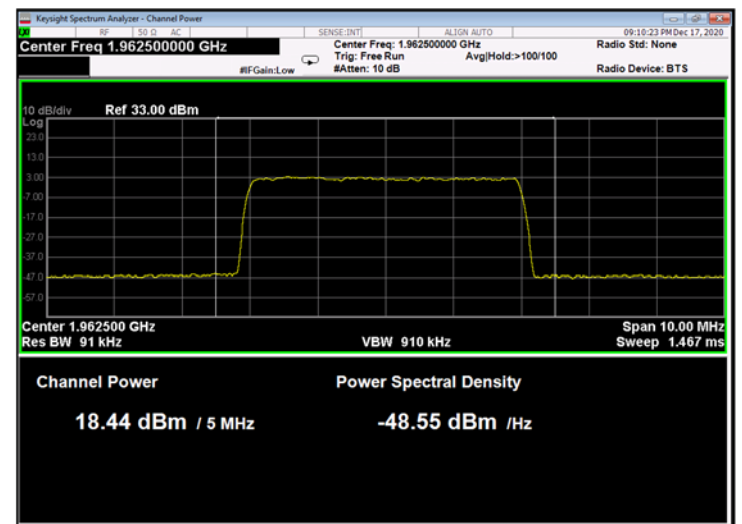

Figure 78: 64QAM 5MHz B.W.; 1962.5MHz, 30kHz

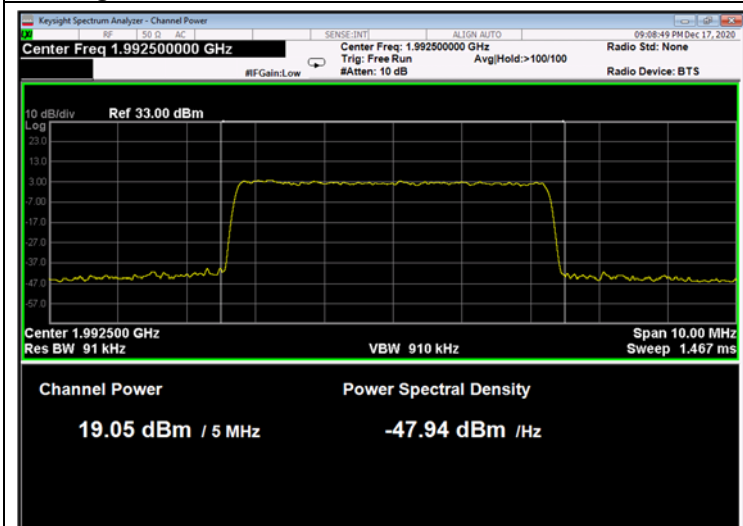

Figure 79: 64QAM 5MHz B.W.; 1992.5MHz, 15kHz

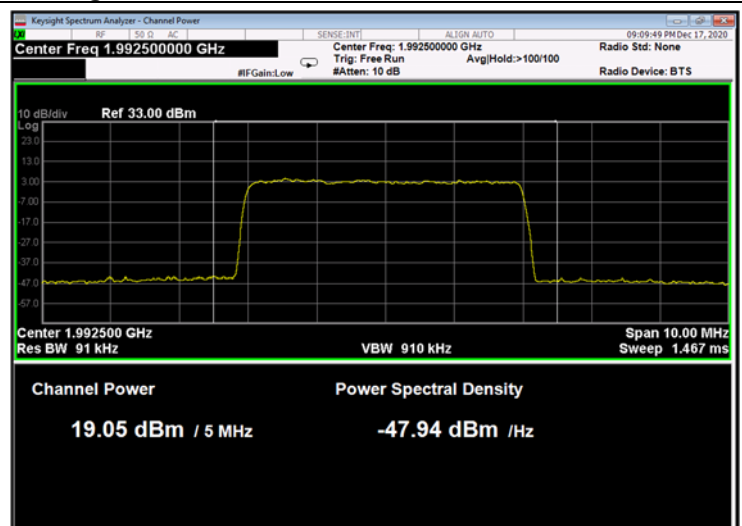

Figure 80: 64QAM 5MHz C.S.; 1992.5MHz, 30kHz

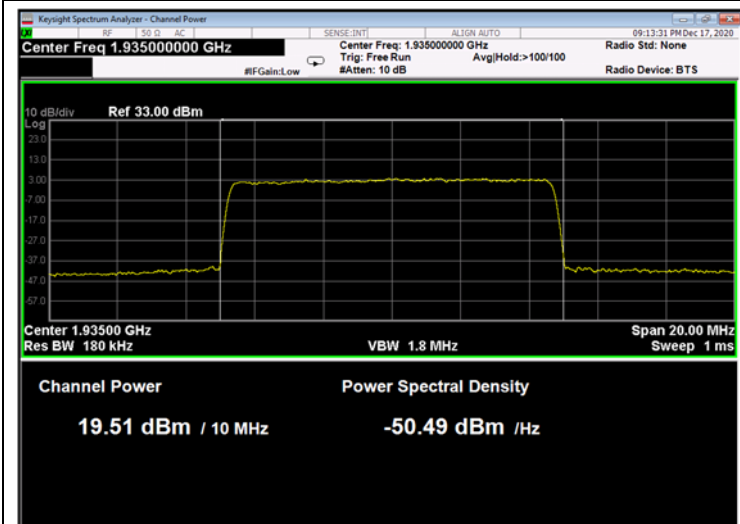

Figure 81: 64QAM 10MHz B.W.; 1935.00MHz, 15kHz

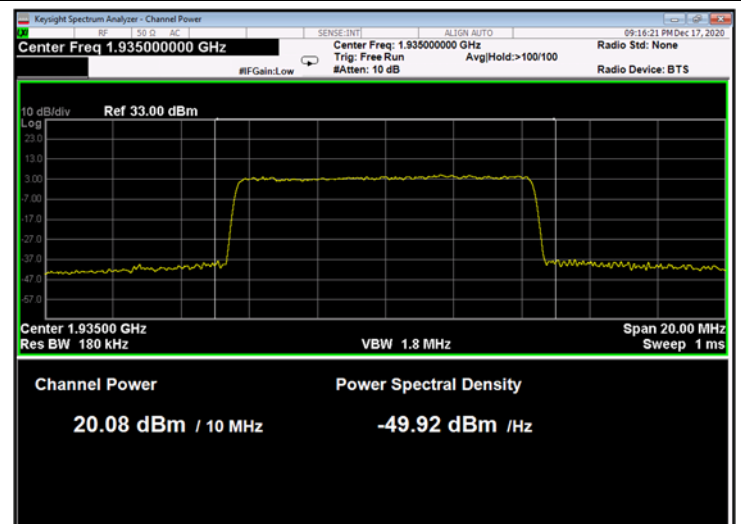

Figure 82: 64QAM 10MHz B.W.; 1935.0MHz, 30kHz

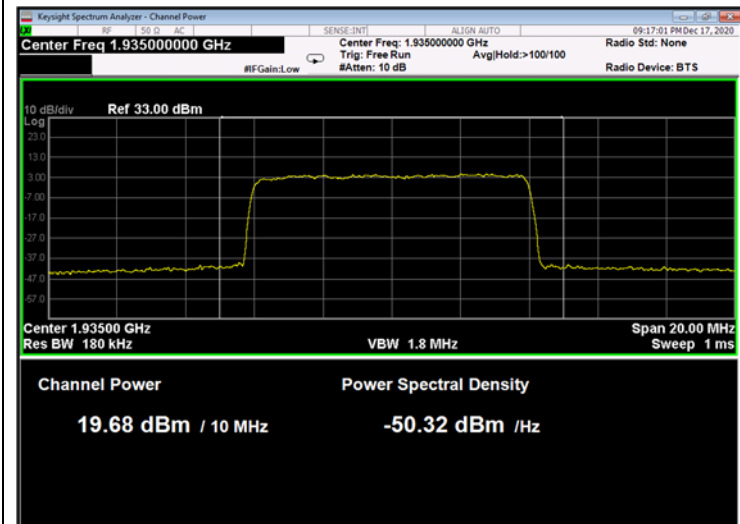

Figure 83: 64QAM 10MHz B.W.; 1935.0MHz, 60kHz

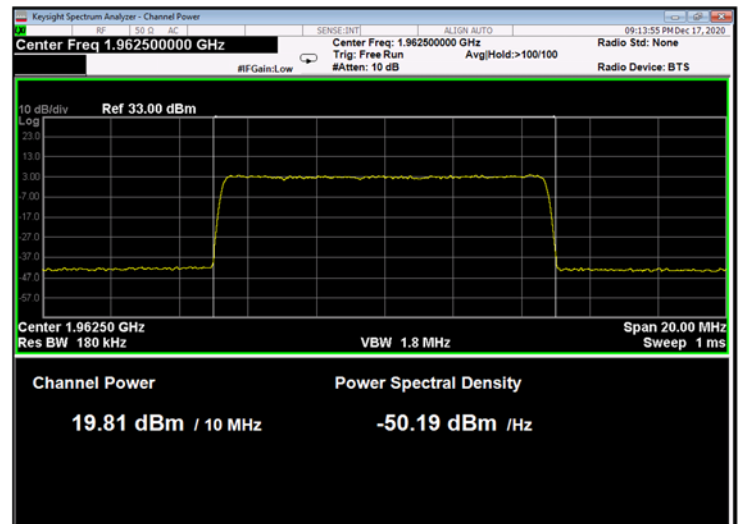

Figure 84: 64QAM 10MHz B.W.; 1962.5MHz, 15kHz

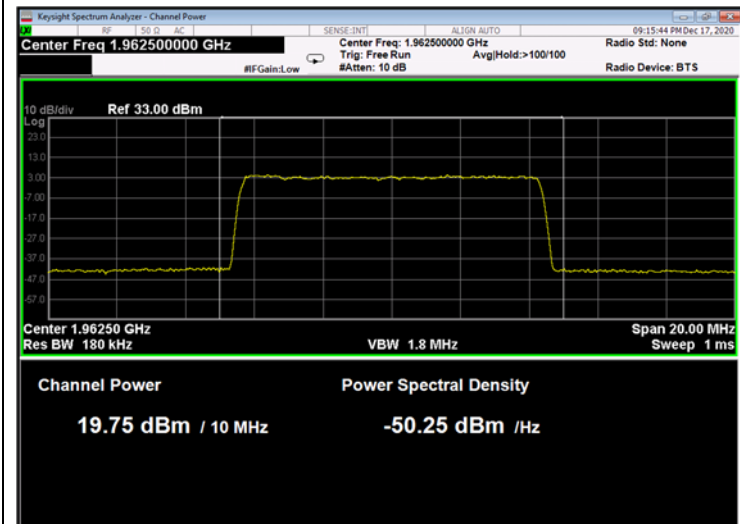

Figure 85: 64QAM 10MHz B.W.; 1962.5MHz, 30kHz

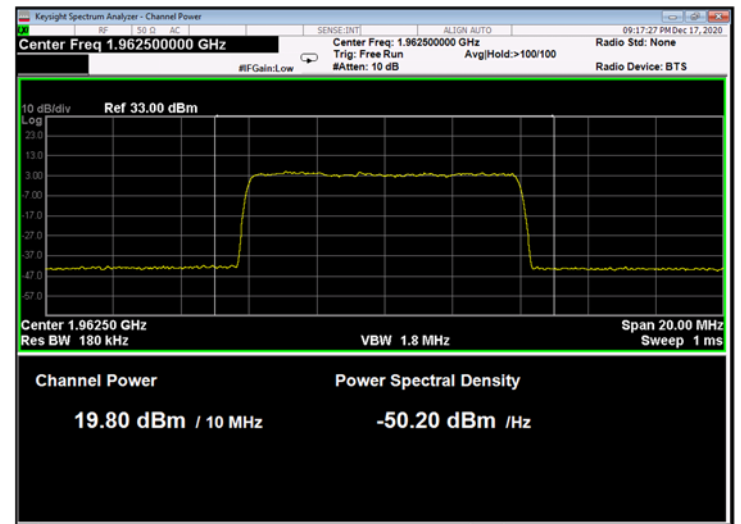

Figure 86: 64QAM 10MHz B.W.; 1962.5MHz, 60kHz