



DATE: 27 December 2016

**I.T.L. (PRODUCT TESTING) LTD.
FCC Radio Test Report
for
Corning Optical Communication
Wireless**

Equipment under test:

ONE - Optical Network Evolution DAS

RAU-5 Remote Antenna Unit

**AWS, CELL/ESMR, LTE, PCS
(PCS Section)**

Tested:

M. Zohar

Approved by:

D. Shidlowky

This report must not be reproduced, except in full, without the written permission of I.T.L. (Product Testing) Ltd.

This report relates only to items tested.



**Measurement/Technical Report for
Corning Optical Communication Wireless
ONE - Optical Network Evolution DAS
(PCS SECTION)
FCC ID: OJF1RAU5**

This report concerns: Original Grant:
Class II change: X
Class I change:

Equipment type: Part 20 Industrial Booster (CMRS)

Limits used: 47CFR Parts 2, 24

Measurement procedure used is KDB 971168 D03 v01 and
KDB 935210 D05 v01r01.

Substitution Method used as in ANSI/TIA-603-D: 2010

Application for Certification
prepared by:
R. Pinchuck
ITL (Product Testing) Ltd.
1 Bat Sheva St.
Lod 7120101
Israel
e-mail rpinchuck@itl.co.il

Applicant for this device:
(different from "prepared by")
Habib Riazi
Corning Optical Communication Wireless
13221 Woodland Park Rd., Suite #400
Herndon, VA. 20171
U.S.A.
Tel: +1-541-758-2880
Fax: +1-703-848-0260
e-mail: RiaziH@corning.com



TABLE OF CONTENTS

1.	GENERAL INFORMATION -----	5
1.1	Administrative Information	5
1.2	List of Accreditations	6
1.3	Product Description	7
1.4	Test Methodology	7
1.5	Test Facility	7
1.6	Measurement Uncertainty.....	7
2.	SYSTEM TEST CONFIGURATION -----	8
2.1	Justification.....	8
2.2	EUT Exercise Software	8
2.3	Special Accessories	8
2.4	Equipment Modifications	8
2.5	Configuration of Tested System	9
3.	TEST SET-UP PHOTOS -----	11
4.	PEAK OUTPUT POWER PCS -----	15
4.1	Test Specification	15
4.2	Test Procedure	15
4.3	Test Limit.....	15
4.4	Test Results	15
4.5	Test Equipment Used; Peak Output Power PCS.....	21
5.	OCCUPIED BANDWIDTH PCS -----	22
5.1	Test Specification	22
5.2	Test Procedure	22
5.3	Test Limit.....	22
5.4	Test Results	22
5.5	Test Equipment Used; Occupied Bandwidth PCS	32
6.	SPURIOUS EMISSIONS AT ANTENNA TERMINALS PCS -----	33
6.1	Test Specification	33
6.2	Test Procedure	33
6.3	Test Limit.....	33
6.4	Test Results	33
6.5	Test Equipment Used; Out of Band Emission at Antenna Terminals PCS.....	37
7.	BAND EDGE SPECTRUM PCS -----	38
7.1	Test Specification	38
7.2	Test Procedure	38
7.3	Test Limit.....	38
7.4	Test Results	38
7.5	Test Equipment Used; Band Edge Spectrum PCS	42
8.	SPURIOUS EMISSIONS (RADIATED) PCS -----	43
8.1	Test Specification	43
8.2	Test Procedure	43
8.3	Test Limit.....	44
8.4	Results Table	44
8.5	Test Instrumentation Used, Radiated Measurements	45
9.	INTERMODULATION CONDUCTED -----	46
9.1	Test Procedure	46
9.2	Test Limit.....	46
9.3	Test Results	46
9.4	Test Equipment Used; Intermodulation Conducted	47



10.	INTERMODULATION RADIATED	48
10.1	Test Procedure	48
10.2	Test Limit	49
10.3	Test Results	49
10.4	Test Instrumentation Used; Radiated Measurements Intermodulation	51
11.	OUT-OF-BAND REJECTION (PCS)	52
11.1	Test Specification	52
11.2	Test Procedure	52
11.3	Test Limit	52
11.4	Test Results	52
11.5	Test Equipment Used; Out-of-Band Rejection	53
12.	APPENDIX A - CORRECTION FACTORS	54
12.1	Correction factors for RF OATS Cable 35m	54
12.2	Correction factors for RF OATS Cable 10m	55
12.3	Correction factors for Horn Antenna	56
12.4	Correction factors for Horn ANTENNA	57
12.5	Correction factors for Log Periodic Antenna	58
12.6	Correction factors for Biconical Antenna	59
12.7	Correction factors for ACTIVE LOOP ANTENNA	60



1. General Information

1.1 Administrative Information

Manufacturer: Corning Optical Communication
Wireless

Manufacturer's Address: 13221 Woodland Park Rd., Suite
#400
Herndon, VA. 20171
U.S.A.
Tel: +1-541-758-2880
Fax: +1-703-848-0260

Manufacturer's Representative: Habib Riazi

Equipment Under Test (E.U.T): ONE - Optical Network Evolution
DAS

Equipment Model No.: RAU-5 Remote Antenna Unit

Equipment Serial No.: 05144900098

Date of Receipt of E.U.T: July 13, 2016

Start of Test: July 17, 2016

End of Test: September 15, 2016

Test Laboratory Location: I.T.L (Product Testing) Ltd.
1 Batsheva St,
Lod,
Israel 7116002

Test Specifications: FCC Parts 2, 24



1.2 List of Accreditations

The EMC laboratory of I.T.L. is accredited by/registered with the following bodies:

1. The American Association for Laboratory Accreditation (A2LA) (U.S.A.), Certificate No. 1152.01.
2. The Federal Communications Commission (FCC) (U.S.A.), FCC Designation Number IL1005.
3. The Israel Ministry of the Environment (Israel), Registration No. 1104/01.
4. The Voluntary Control Council for Interference by Information Technology Equipment (VCCI) (Japan), Registration Numbers: C-3006, R-2729, T-1877, G-245.
5. Industry Canada (Canada), IC File No.: 46405-4025; Site No. IC 4025A-1, IC 4025A-2.

I.T.L. Product Testing Ltd. is accredited by the American Association for Laboratory Accreditation (A2LA) and the results shown in this test report have been determined in accordance with I.T.L.'s terms of accreditation unless stated otherwise in the report.



1.3 Product Description

The Optical Network Platform (ONE™) by Corning provides a flexible in-building RF and network digital coverage solution based on a fiber optic transport backbone.

The fiber-optics infrastructure is easily deployable via a wide range of pre-terminated composite cables and advanced end-to-end equipment. Easy to design, Plug and Play™ connectors, significantly reduce installation cost and deployment time.

The ONE™ solution is an ideal fit for large, high-rise or campus-style deployments. It generates significant CAPEX savings and OPEX savings through the use of user configurable sectorization and an infrastructure that is simple to deploy and efficient in usage.

Dynamic sectorization management allows precise service distribution control to meet changing density needs, and provides further savings by enabling sharing of equipment at various levels for service providers.

Radio source agnostic, remote units can be used as network extenders. Ethernet capability with dedicated fiber link for Wi-Fi offload brings a higher level of granularity and support for devices and applications with very high speed requirements.

1.4 Test Methodology

Both conducted and radiated testing were performed according to the procedures in KDB 971168 D03 v01, KDB 935210 D05 v01r01 and ANSI/TIA-603-D: 2010. Radiated testing was performed at an antenna to EUT distance of 3 meters.

1.5 Test Facility

Both conducted and radiated emissions tests were performed at I.T.L.'s testing facility in Lod, Israel. I.T.L.'s EMC Laboratory is accredited by A2LA, certificate No. 1152.01 and its FCC Designation Number is IL1005.

1.6 Measurement Uncertainty

Conducted Emission (CISPR 11, EN 55011, CISPR 22, EN 55022, ANSI C63.4)

0.15 – 30 MHz:

Expanded Uncertainty (95% Confidence, K=2):

± 3.44 dB

Radiated Emission (CISPR 11, EN 55011, CISPR 22, EN 55022, ANSI C63.4) for open site 30-1000MHz:

Expanded Uncertainty (95% Confidence, K=2):

± 4.98 dB



2. System Test Configuration

2.1 *Justification*

The E.U.T. was originally FCC certified on 12/26/2014 under FCC ID: OJF1RAU5.

The E.U.T. is part of a booster system operated with the RXU certified under FCC ID: OJF1RXU.

No changes have been made to the E.U.T.

The C2PC change is to allow the E.U.T. to operate as part of a booster system with the new RXU2325 certified under FCC ID: OJF1RXUN.

The E.U.T. has been fully tested with the RXU2325 and results presented in the four reports (for bands AWS, CELL/ESMR, PCS & LTE) submitted with this application.

The test setup was configured to closely resemble the standard installation.

The EUT consists of the HEU, the OIU and the RAU-5.

All source signals are represented in the setup by appropriate signal generators.

An “Exercise” SW on the computer was used to enable / disable transmission of the RAU-5, while the EUT output was connected to the spectrum analyzer.

All channels transmitted during the testing.

There is neither an intermediate amplified nor donor antenna in the uplink.

All components included in the UL path are connected by cables.

2.2 *EUT Exercise Software*

HCM_2.2 Build23

ACM_2a00_22_11.bin

RMM_5a00_22_02. bin

OIM_7a03_22_05. bin

RAU5_9a64_22_12.bin

2.3 *Special Accessories*

No special accessories were needed in order to achieve compliance.

2.4 *Equipment Modifications*

No modifications were needed in order to achieve compliance.

2.5 Configuration of Tested System

Product Name	ONE Wireless Platform
Model Name	RAU5
Working voltage	48.0VDC
Mode of operation	Industrial Booster for PCS band
Modulations	WCDMA, LTE(64QAM), GSM
Assigned Frequency Range	1930.0MHz-1995.0MHz
Transmit power	~20.0 dBm
Antenna Gain	12.5dBi
DATA rate	N/A
Modulation BW	0.5MHz(GSM), 10MHz(LTE), 5MHz(WCDMA)

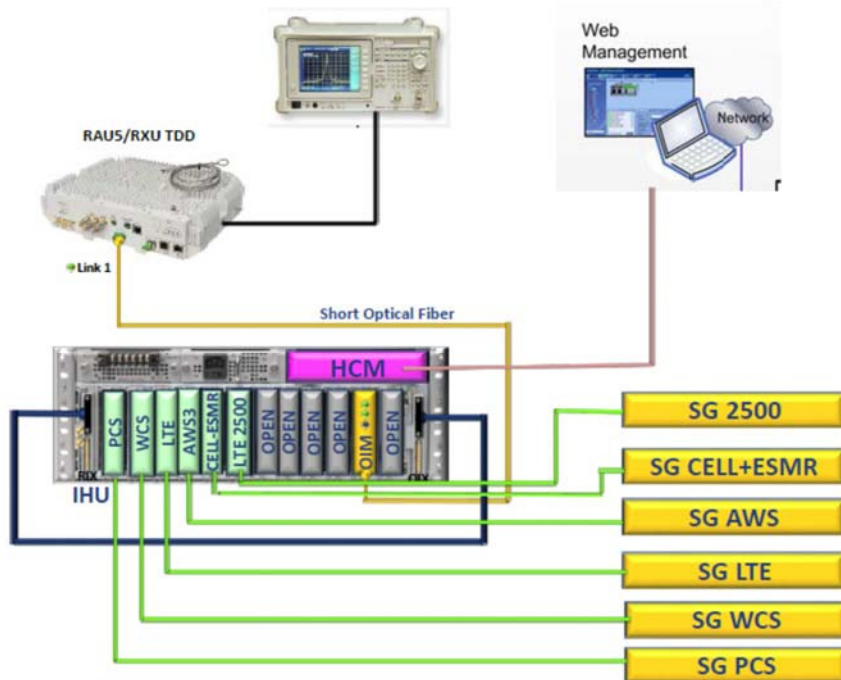

Figure 1. Test Set-Up – Conducted

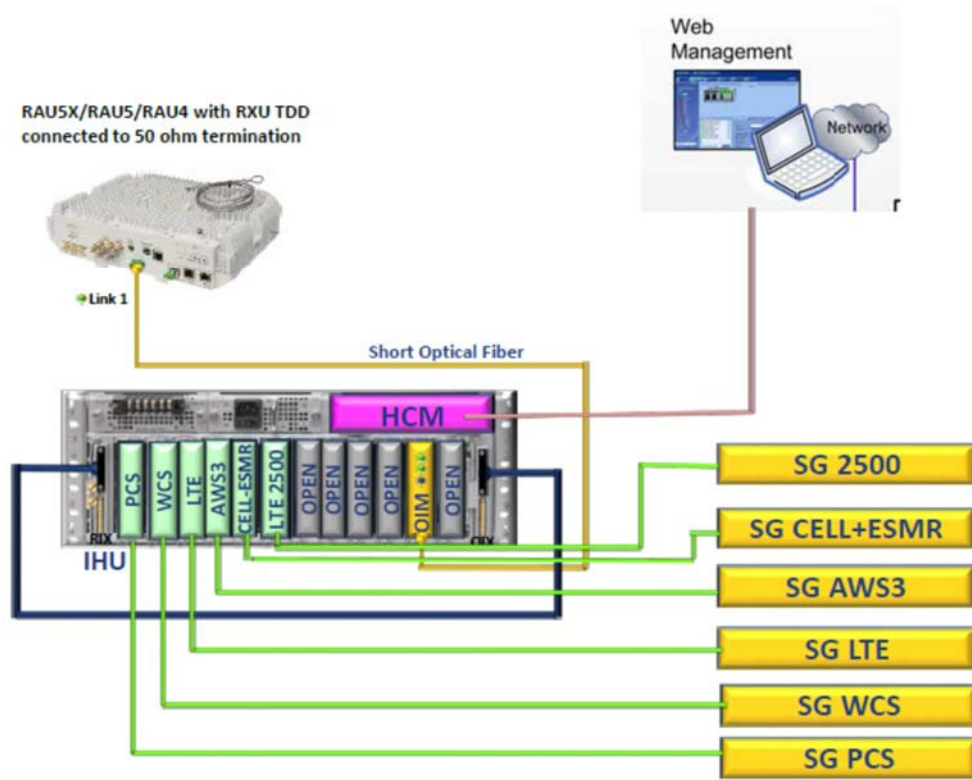

Figure 2. Test Set-Up - Radiated

3. Test Set-Up Photos



Figure 3. Conducted Emission From Antenna Port Tests

t



Figure 4. Radiated Emission Test



Figure 5. Radiated Emission Test

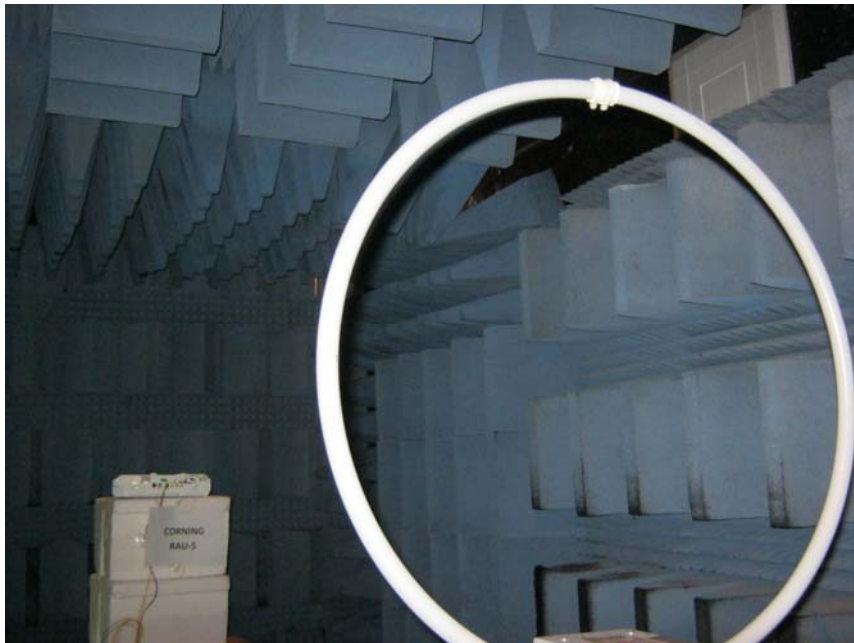

Figure 6. Radiated Emission Test



Figure 7. Radiated Emission Test

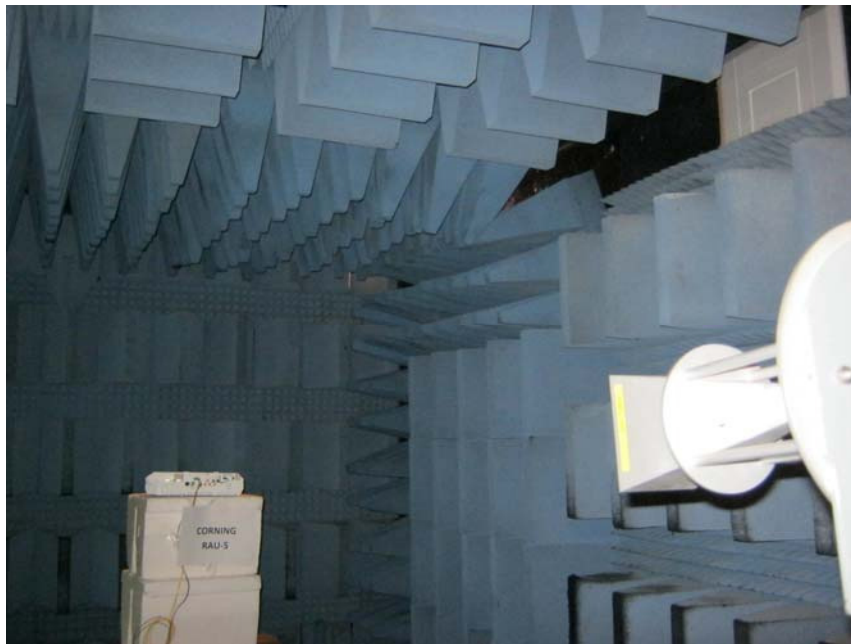

Figure 8. Radiated Emission Test

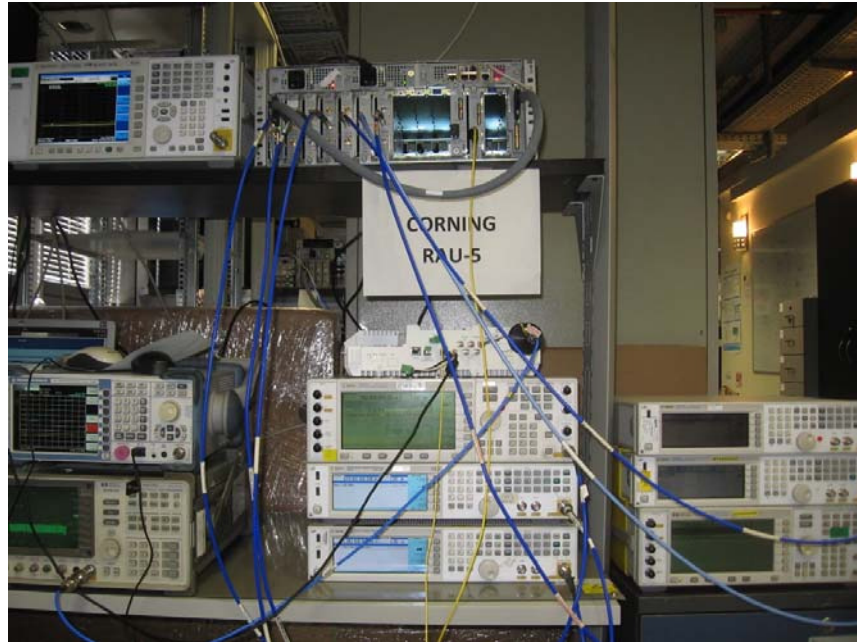

Figure 9. Intermodulated Conducted Emission Test



4. Peak Output Power PCS

4.1 Test Specification

FCC Part 24, Subpart E

4.2 Test Procedure

(Temperature (22°C)/ Humidity (36%RH))

The E.U.T. antenna terminal was connected to the Spectrum Analyzer through an external attenuator and an appropriate coaxial cable (loss = 31.0 dB). The E.U.T. RF output was modulated with W-CDMA, GSM and LTE 64QAM. Special attention was taken to prevent Spectrum Analyzer RF input overload.

4.3 Test Limit

Peak Power Output must not exceed 100 Watts (50dBm).

4.4 Test Results

Modulation	Operation Frequency	Reading	Antenna Gain	EIRP	Limit	Margin
	(MHz)	(dBm)	(dBi)	(dBm)	(dBm)	(dB)
LTE 64QAM	1935.0	20.1	12.5	32.6	50.0	-17.4
	1962.5	21.8	12.5	34.3	50.0	-15.7
	1990.0	20.4	12.5	32.9	50.0	-17.1
GSM	1931.2	20.4	12.5	32.9	50.0	-17.1
	1962.5	21.4	12.5	33.9	50.0	-16.1
	1993.8	21.3	12.5	33.8	50.0	-16.2
W-CDMA	1932.5	20.4	12.5	32.9	50.0	-17.1
	1962.5	20.3	12.5	32.8	50.0	-17.2
	1992.5	21.5	12.5	34.0	50.0	-16.0

Figure 10 Peak Output Power PCS

JUDGEMENT: Passed by 15.7dB

See additional information in *Figure 11 to Figure 19.*

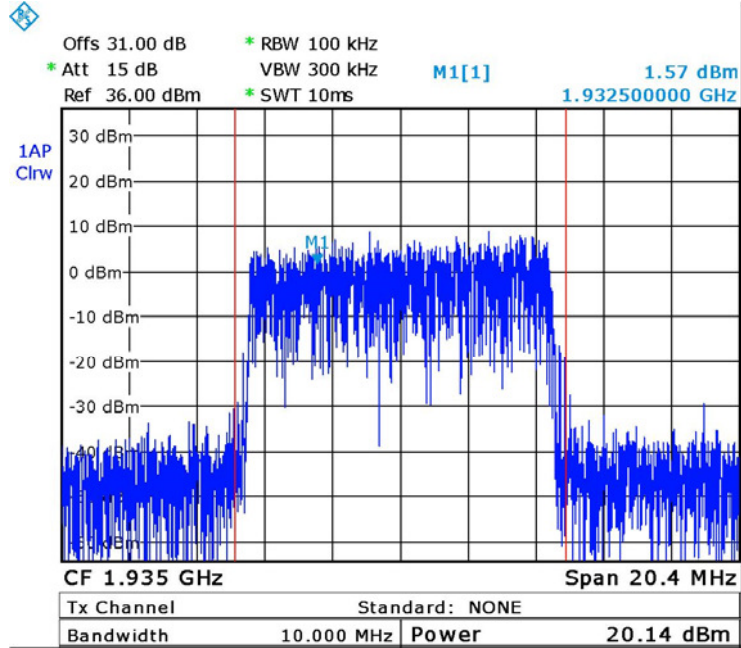

Date: 17.JUL.2016 09:43:30

Figure 11. — LTE 64QAM 1935.0 MHz

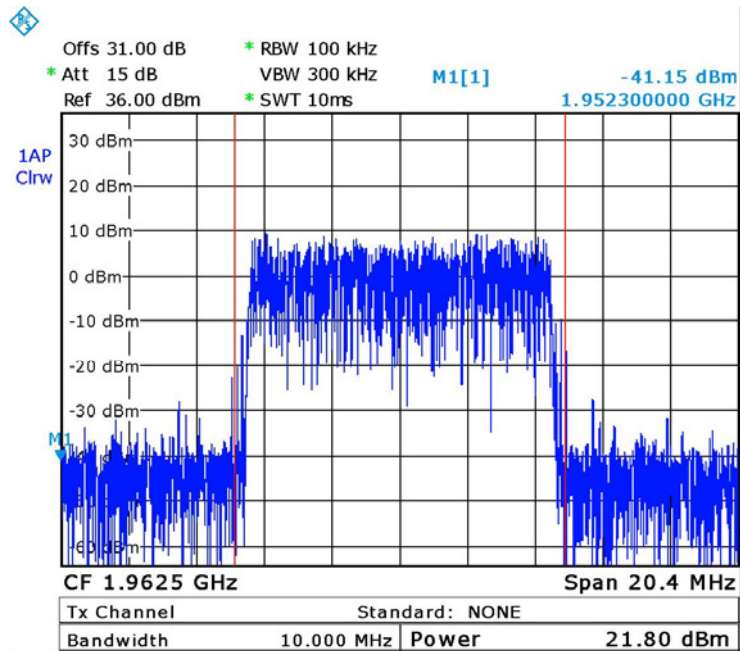

Date: 17.JUL.2016 09:44:38

Figure 12. — LTE 64QAM 1962.5 MHz

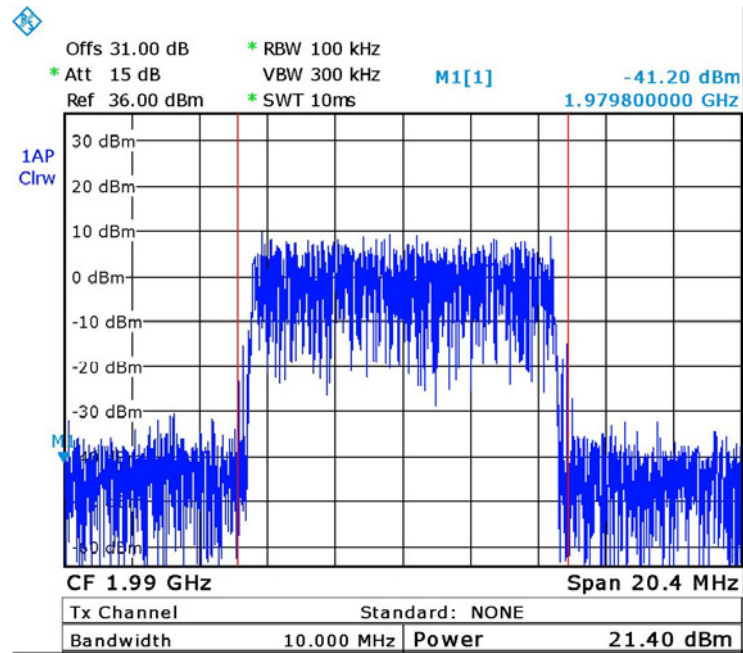

Date: 17.JUL.2016 09:45:17

Figure 13. — LTE 64QAM 1990.0 MHz

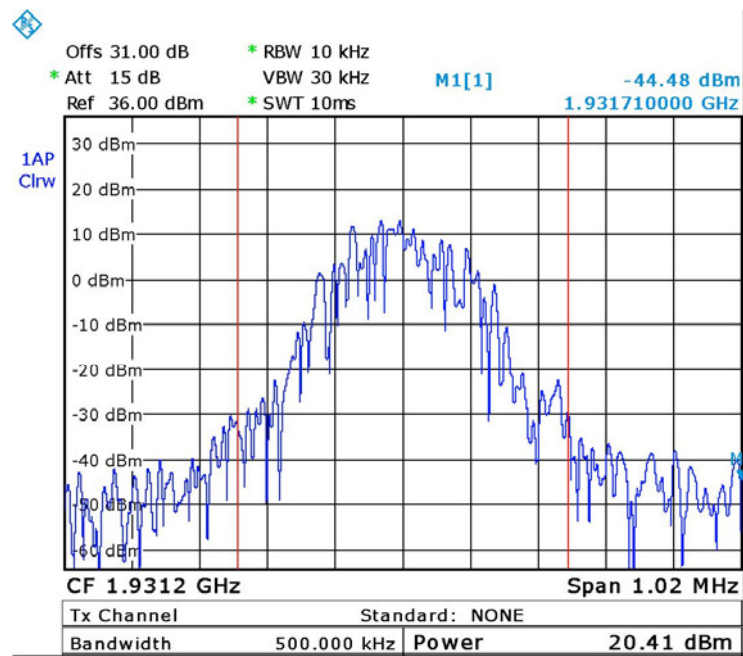

Date: 17.JUL.2016 09:50:27

Figure 14. — GSM - 1931.2 MHz

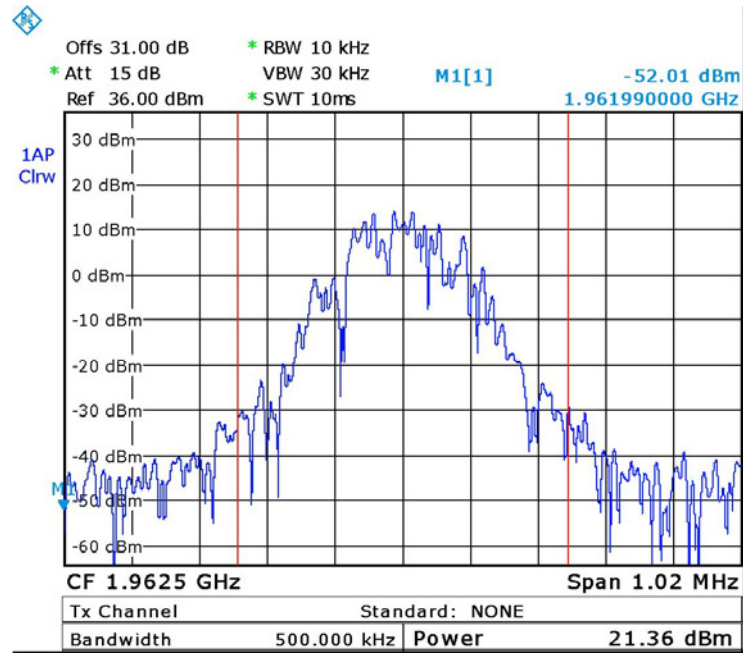

Date: 17.JUL.2016 09:55:43

Figure 15. — GSM -1962.5 MHz

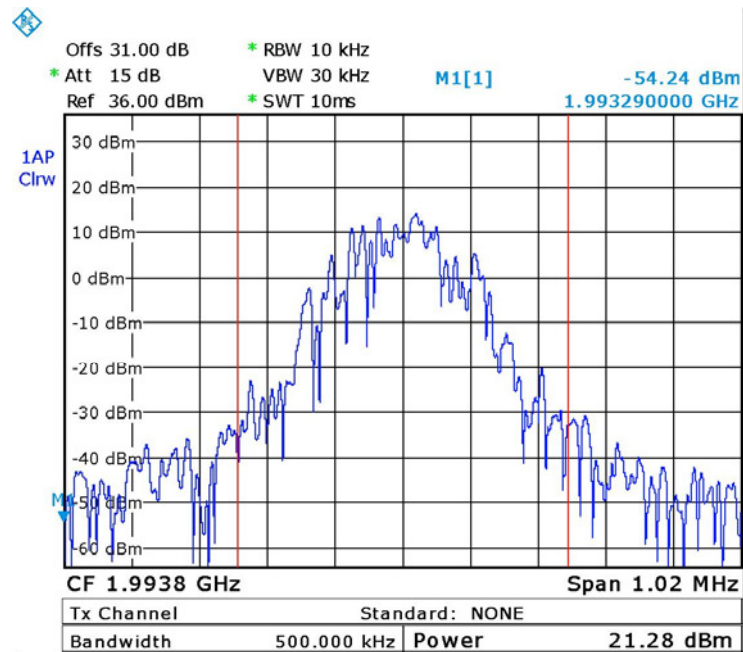

Date: 17.JUL.2016 09:57:24

Figure 16. — GSM -1993.8 MHz

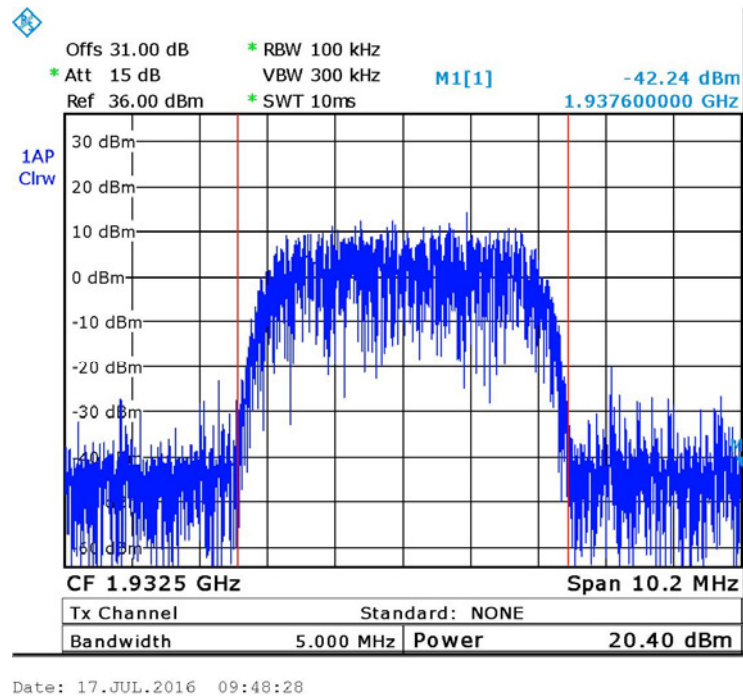

Figure 17. — W-CDMA - 1932.5 MHz

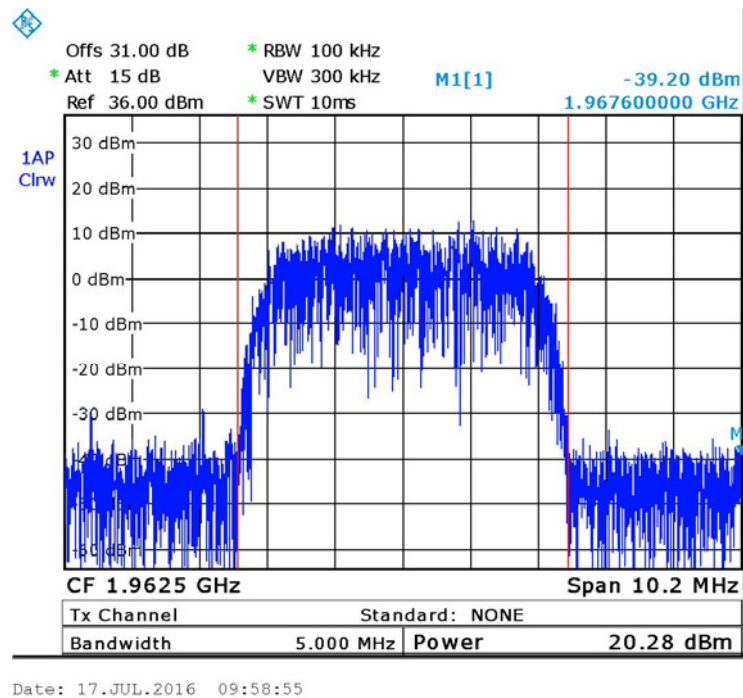
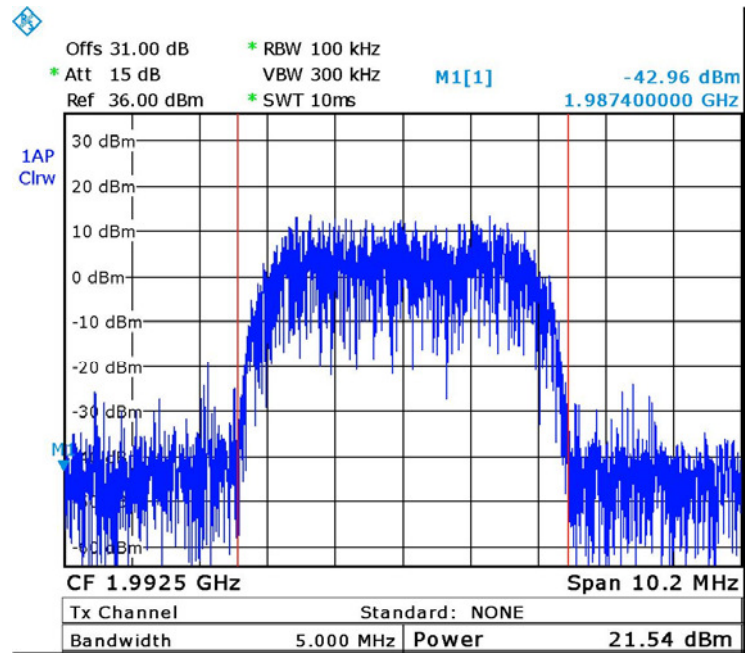

Figure 18. — W-CDMA - 1962.5 MHz



Date: 17.JUL.2016 09:47:16

Figure 19. — W-CDMA - 1992.5 MHz



4.5 Test Equipment Used; Peak Output Power PCS

Instrument	Manufacturer	Model	Serial Number	Calibration	
				Last Calibration Date	Next Calibration Due
Spectrum Analyzer	R&S	FSL6	100194	February 29, 2016	March 1, 2017
Vector Signal Generator	Agilent	N5172B	MY51350584	July 1, 2016	July 1, 2017
30 dB Attenuator	MCL	BW-S30W5	533	July 5, 2016	July 5, 2017

Figure 20 Test Equipment Used

5. Occupied Bandwidth PCS

5.1 Test Specification

FCC Part 2, Section 1049

5.2 Test Procedure

(Temperature (22°C)/ Humidity (38%RH))

The E.U.T. antenna terminal was connected to the spectrum analyzer through an external attenuator and an appropriate coaxial cable (loss=31.0 dB). The spectrum analyzer was set to proper resolution B.W.

OBW function (99%) was employed for this evaluation.

Occupied bandwidth measured was repeated in the input terminal of the E.U.T.

5.3 Test Limit

N/A

5.4 Test Results

Modulation	Port	Operating Frequency	Reading
	(Input/ Output)	(MHz)	(MHz)
LTE 64QAM	Input	1935.0	8.9
	Output	1935.0	8.9
	Input	1962.5	8.9
	Output	1962.5	8.9
	Input	1990.0	8.9
	Output	1990.0	8.9
GSM	Input	1931.2	0.2
	Output	1931.2	0.2
	Input	1962.5	0.2
	Output	1962.5	0.2
	Input	1993.8	0.2
	Output	1993.8	0.2
W-CDMA	Input	1932.5	4.1
	Output	1932.5	4.1
	Input	1962.5	4.1
	Output	1962.5	4.1
	Input	1992.5	4.1
	Output	1992.5	4.1

Figure 21 Occupied Bandwidth PCS

JUDGEMENT: Passed

See additional information in Figure 22 to Figure 39.

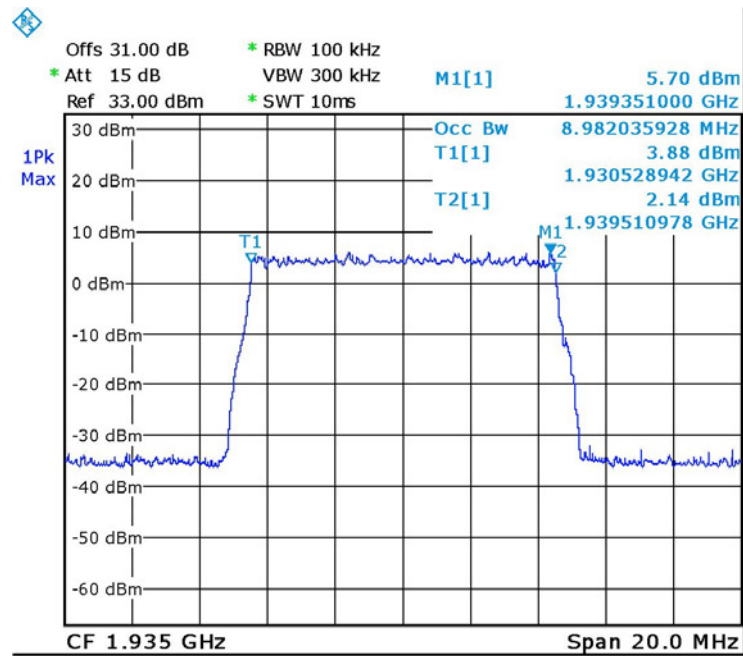

Date: 17.JUL.2016 10:22:19

Figure 22. — LTE 64QAM Input 1935.0 MHz

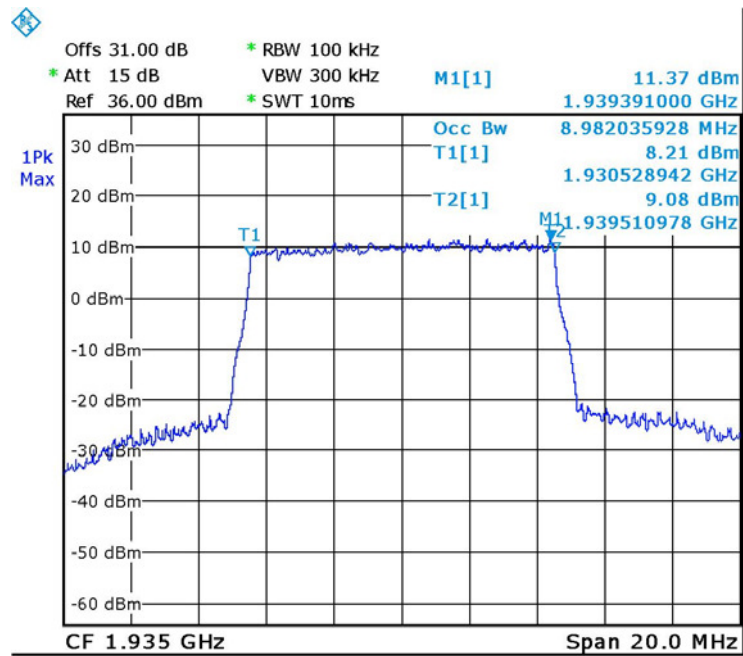

Date: 17.JUL.2016 10:10:34

Figure 23. — LTE 64QAM Output 1935.0 MHz

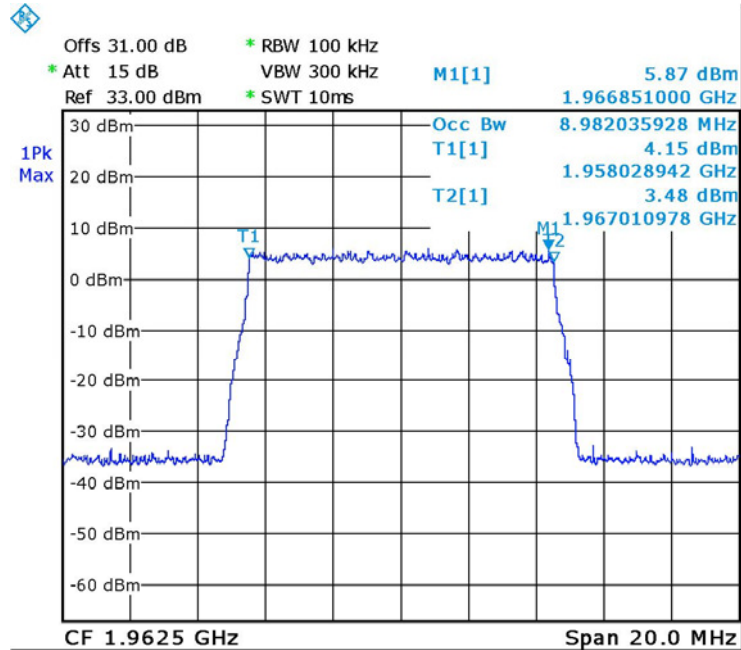

Date: 17.JUL.2016 10:22:49

Figure 24. — LTE 64QAM Input 1962.5 MHz

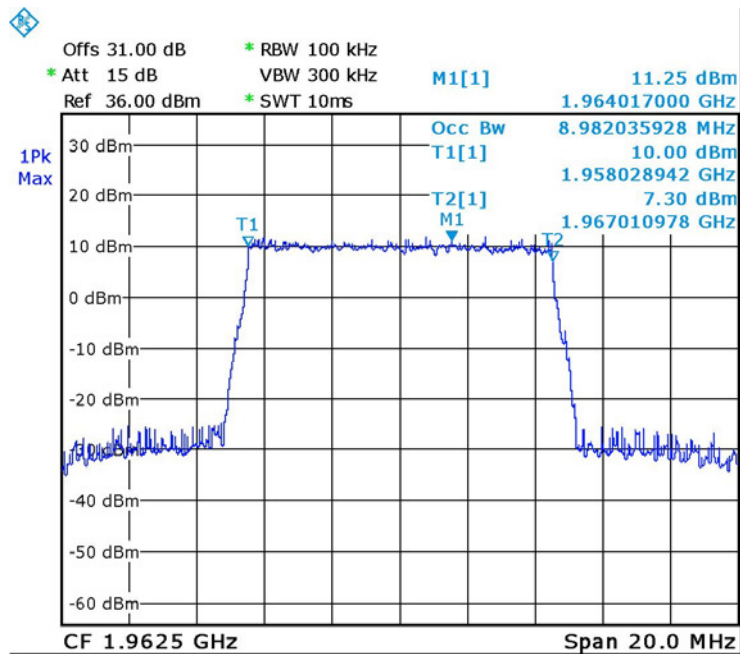

Date: 17.JUL.2016 10:11:12

Figure 25. — LTE 64QAM Output 1962.5 MHz

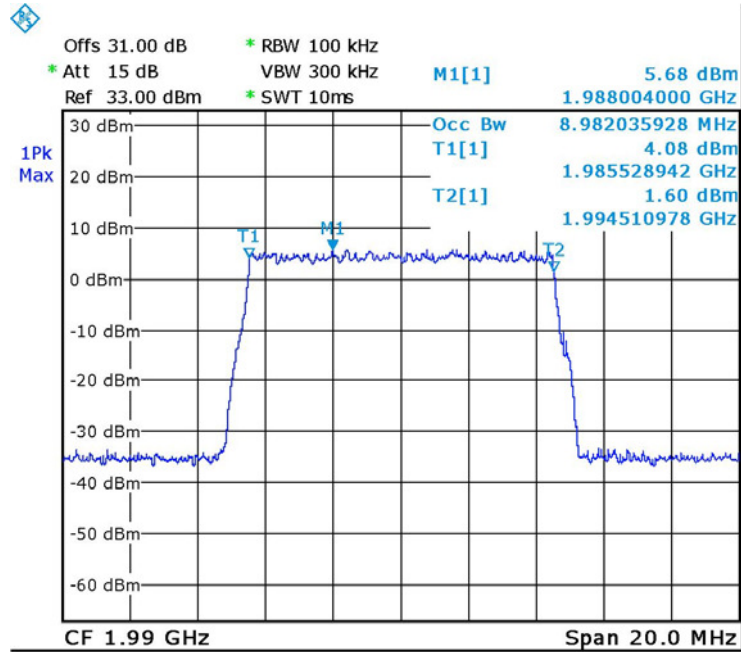

Date: 17.JUL.2016 10:23:25

Figure 26. — LTE 64QAM Input 1990.0 MHz

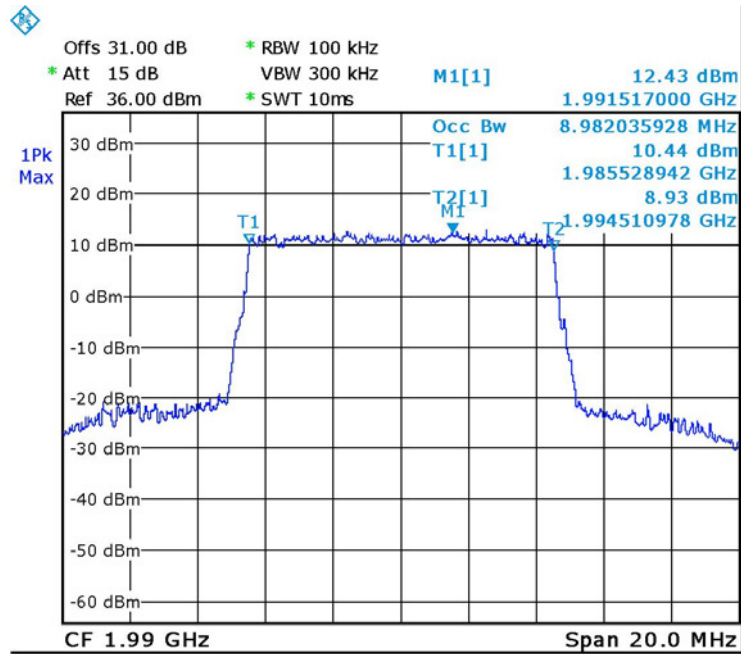

Date: 17.JUL.2016 10:11:53

Figure 27. — LTE 64QAM Output 1990.0 MHz

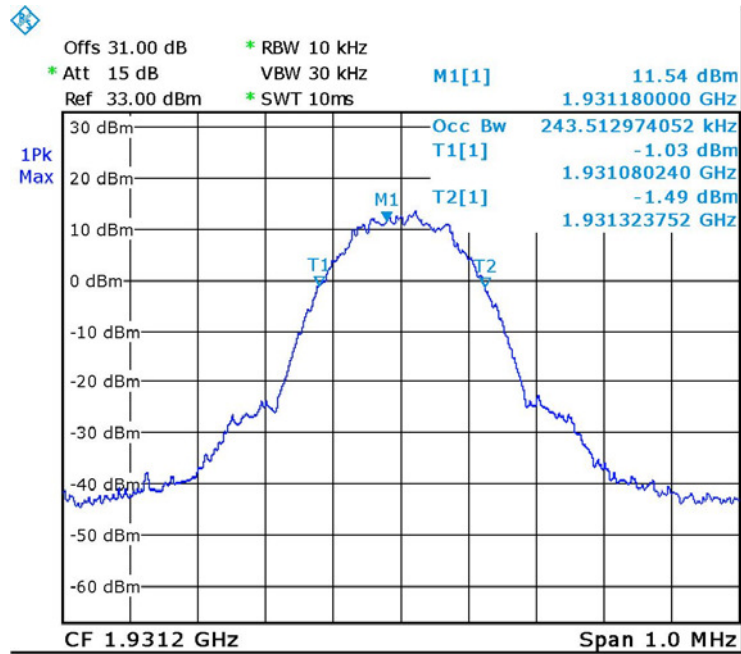

Date: 17.JUL.2016 10:21:12

Figure 28. — GSM - Input 1931.2 MHz

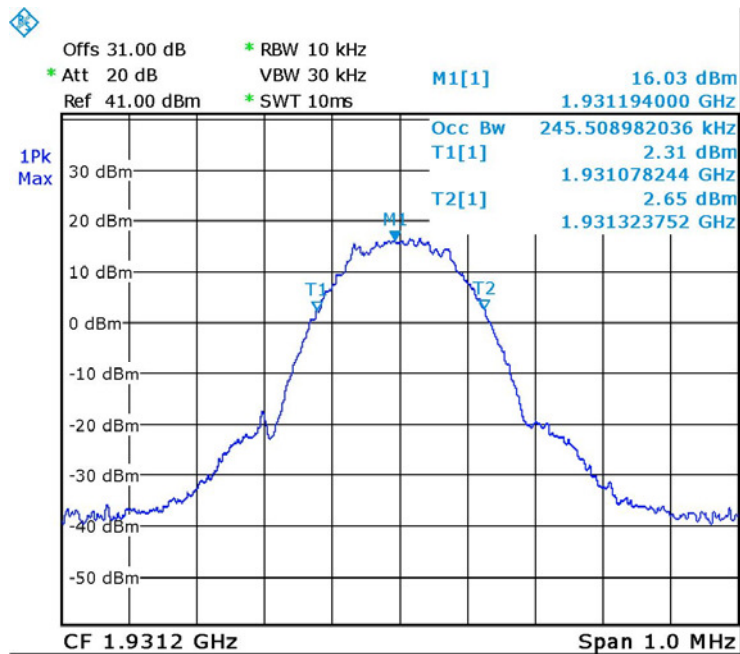

Date: 17.JUL.2016 10:13:59

Figure 29. — GSM - Output 1931.2 MHz

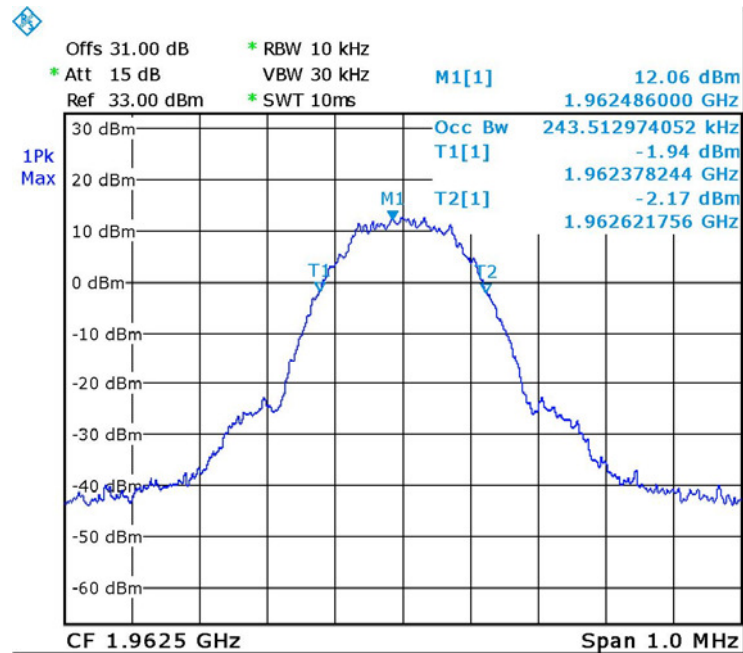

Date: 17.JUL.2016 10:20:41

Figure 30. — GSM - Input 1962.5 MHz

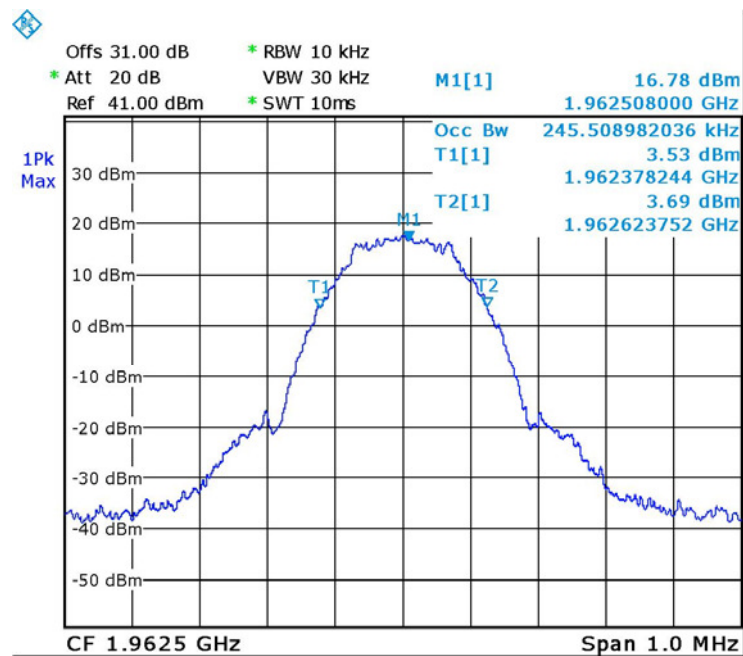

Date: 17.JUL.2016 10:14:37

Figure 31. — GSM - Output 1962.5 MHz

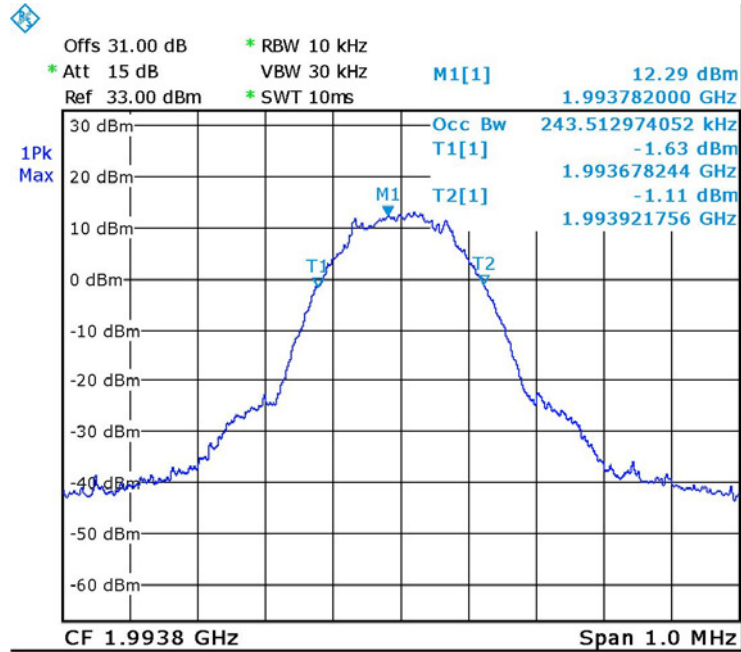

Date: 17.JUL.2016 10:19:59

Figure 32. — GSM - Input 1993.8 MHz

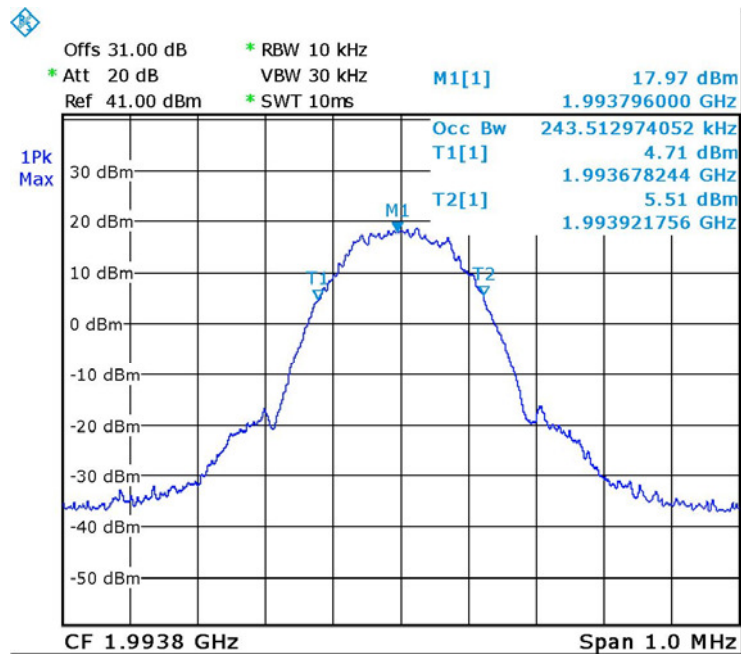

Date: 17.JUL.2016 10:16:54

Figure 33. — GSM - Output 1993.8 MHz

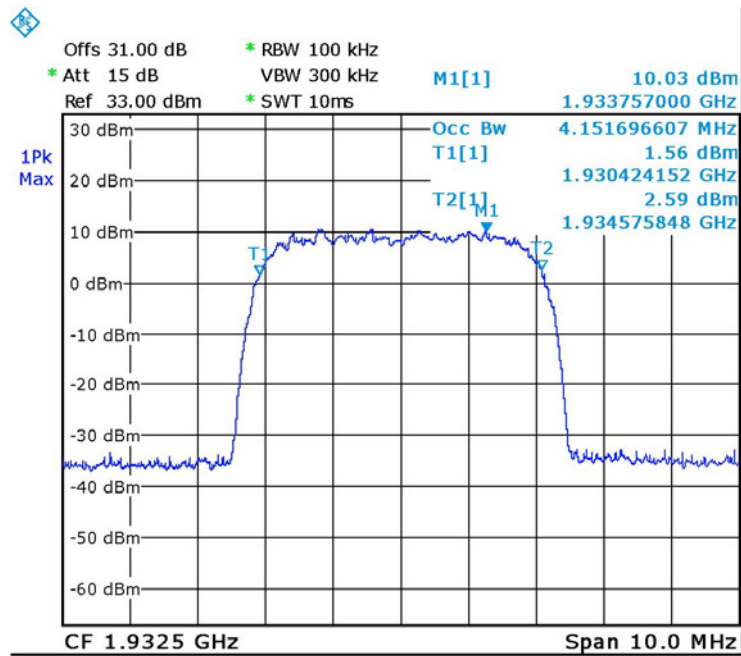

Date: 17.JUL.2016 10:26:26

Figure 34. — W-CDMA - Input 1932.5 MHz

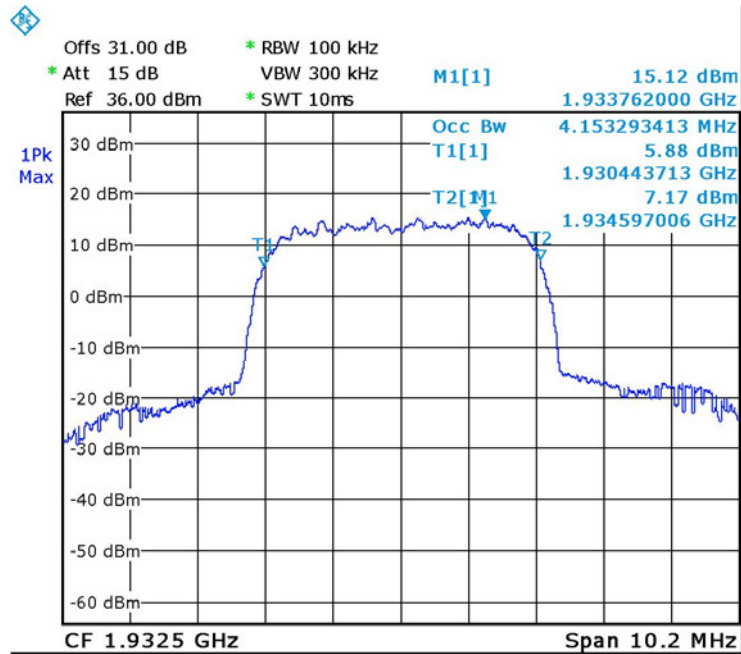

Date: 17.JUL.2016 10:08:40

Figure 35. — W-CDMA - Output 1932.5 MHz

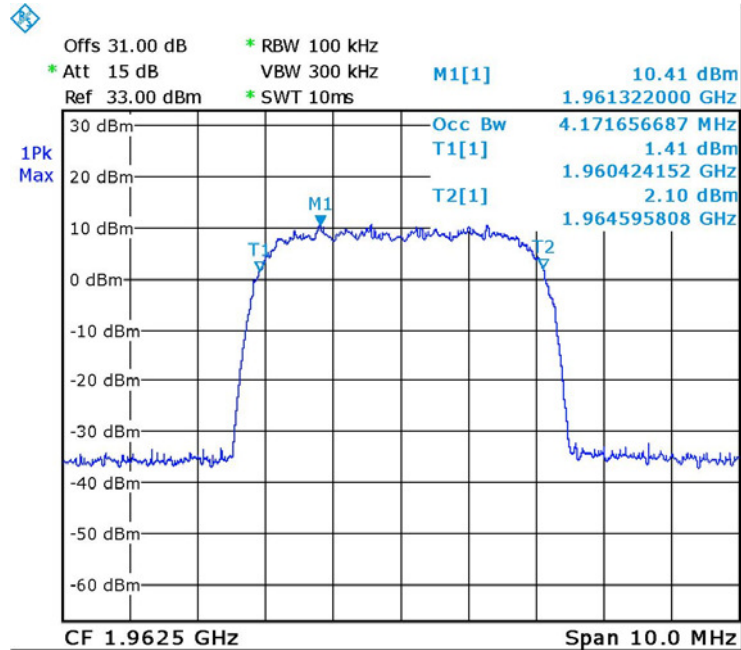

Date: 17.JUL.2016 10:25:42

Figure 36. — W-CDMA - Input 1962.5 MHz

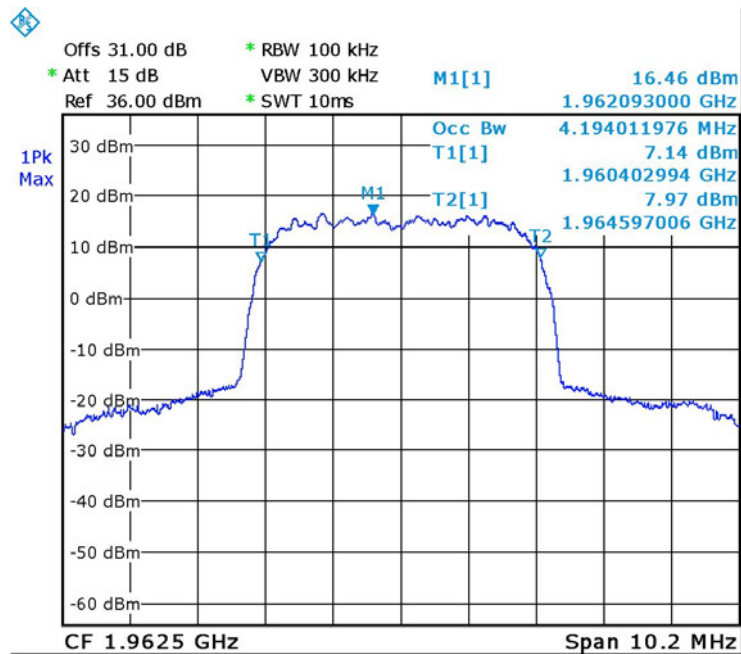

Date: 17.JUL.2016 10:06:03

Figure 37. — W-CDMA - Output 1962.5 MHz

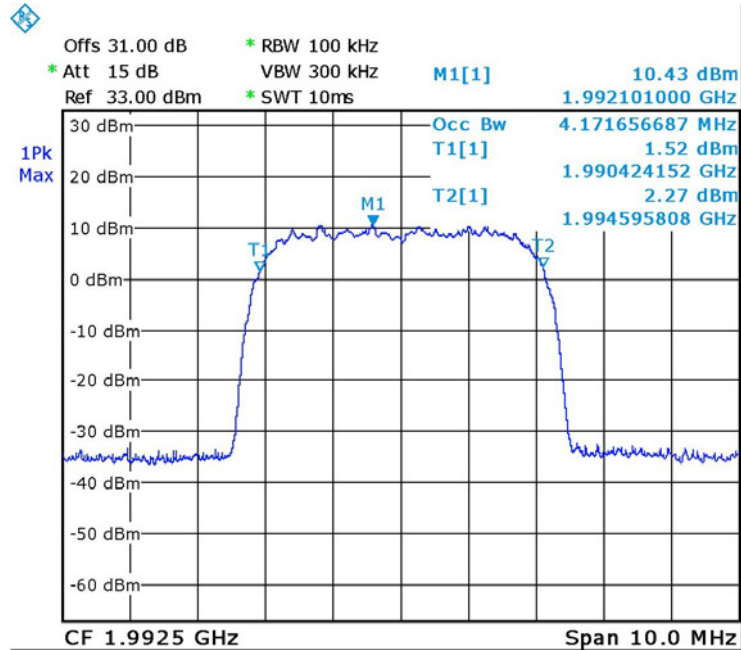

Date: 17.JUL.2016 10:25:11

Figure 38. — W-CDMA - Input 192.5 MHz

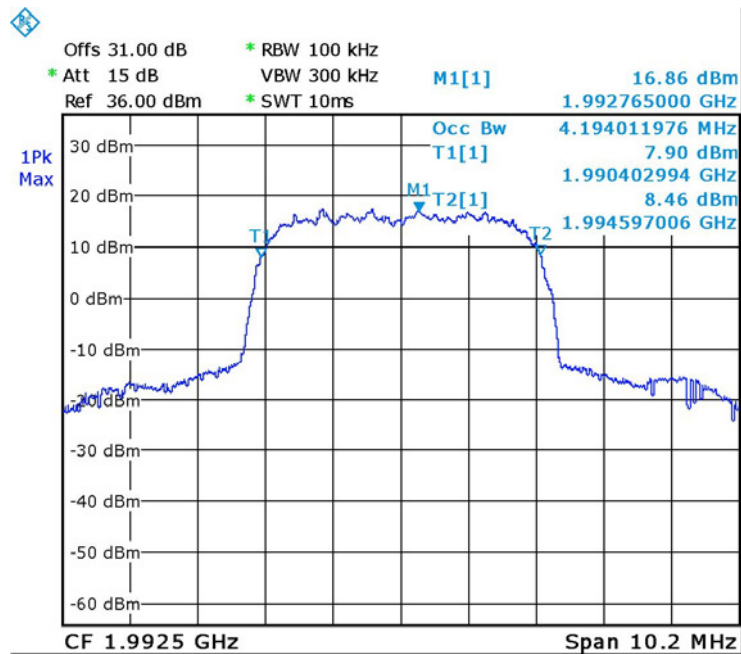

Date: 17.JUL.2016 10:07:38

Figure 39. — W-CDMA - Output 192.5 MHz



5.5 Test Equipment Used; Occupied Bandwidth PCS

Instrument	Manufacturer	Model	Serial Number	Calibration	
				Last Calibration Date	Next Calibration Due
Spectrum Analyzer	R&S	FSL6	100194	February 29, 2016	March 1, 2017
Vector Signal Generator	Agilent	N5172B	MY51350584	July 1, 2016	July 1, 2017
30 dB Attenuator	MCL	BW-S30W5	533	July 5, 2016	July 5, 2017

Figure 40 Test Equipment Used



6. Spurious Emissions at Antenna Terminals PCS

6.1 Test Specification

FCC Part 24, Subpart E, Section 238; FCC Part 2.1051

6.2 Test Procedure

(Temperature (22°C)/ Humidity (36%RH))

The E.U.T. antenna terminal was connected to the spectrum analyzer through an external attenuator and an appropriate coaxial cable (max loss=33.0 dB). The spectrum analyzer was set to 1 kHz resolution BW for the frequency range 9.0-150.0 kHz, 10 kHz for the frequency range 150 kHz-1.0 MHz, 100 kHz for the frequency range 1.0 MHz – 30 MHz, and 1MHz for the frequency range 1.0 GHz - 20.0 GHz.

6.3 Test Limit

The power of any emission outside of the authorized operating frequency ranges(1930-1990 MHz) must be attenuated below the transmitting power (P) by a factor of at least $43 + \log (P)$ dB, yielding -13dBm.

6.4 Test Results

JUDGEMENT: Passed

See additional information in *Figure 41* to *Figure 49*.

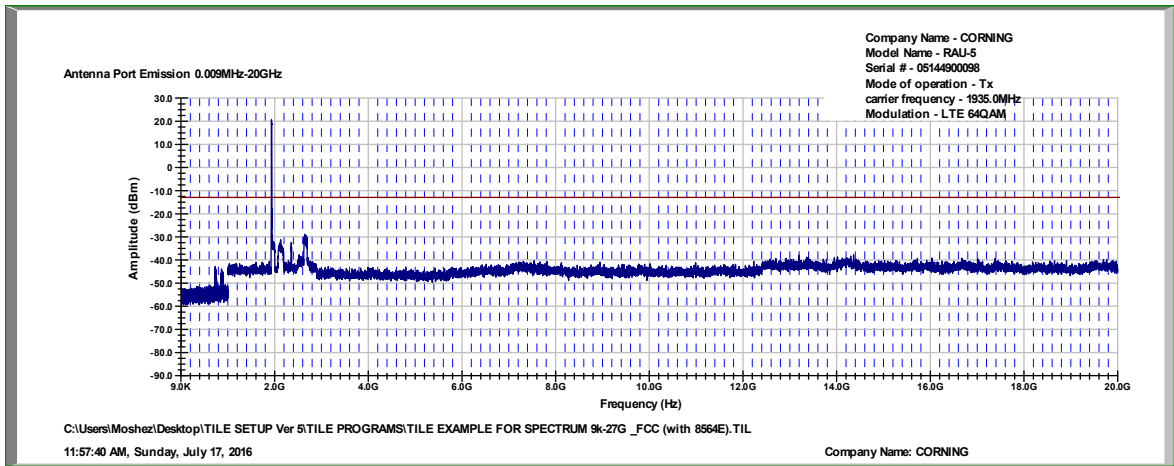

Figure 41. — LTE 64QAM - 1935.0 MHz

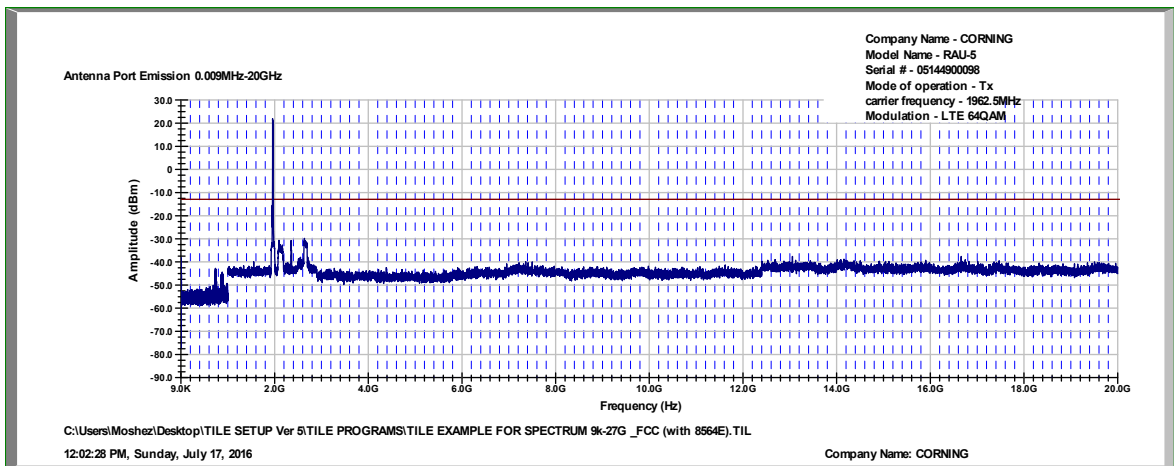

Figure 42. — LTE 64QAM - 1962.5 MHz

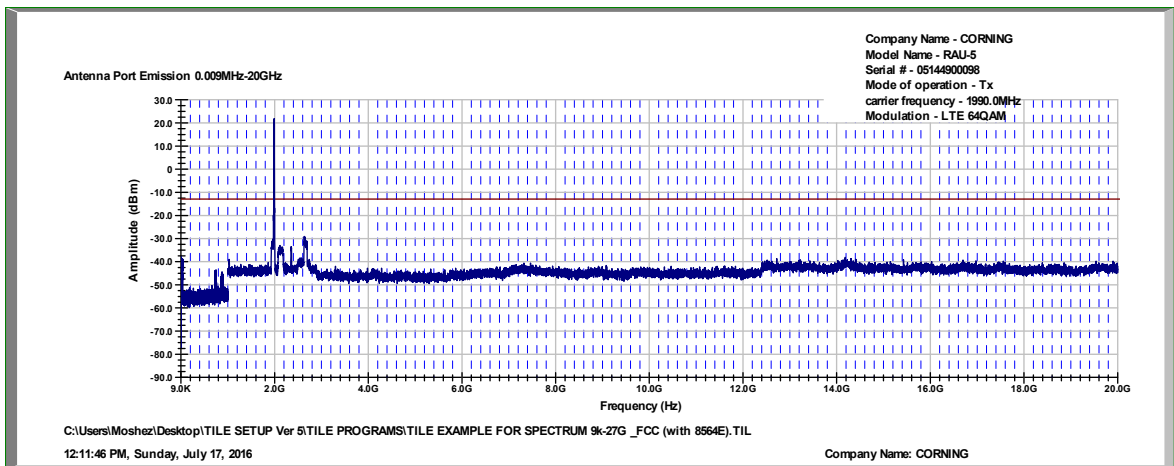

Figure 43. — LTE 64QAM - 1990.0 MHz

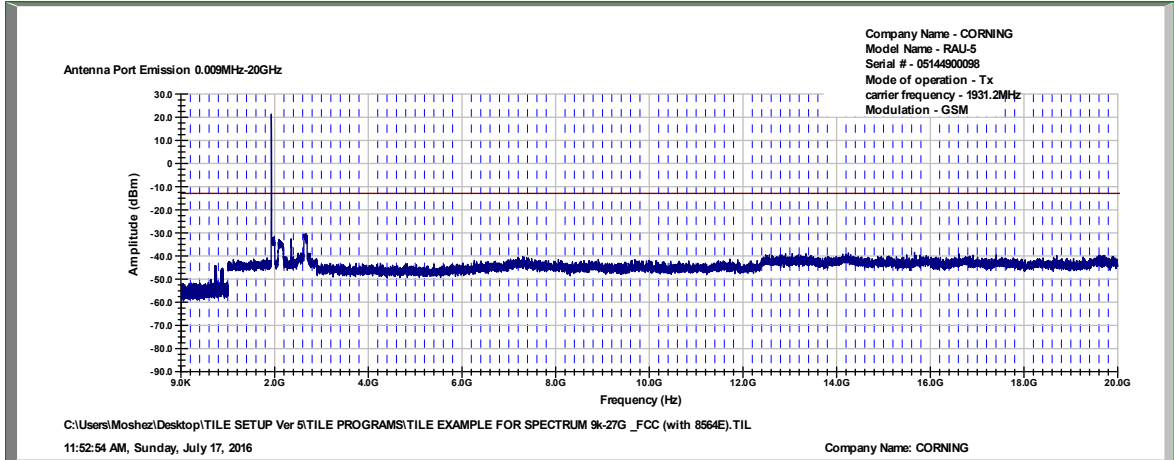

Figure 44. — GSM - 1931.2 MHz

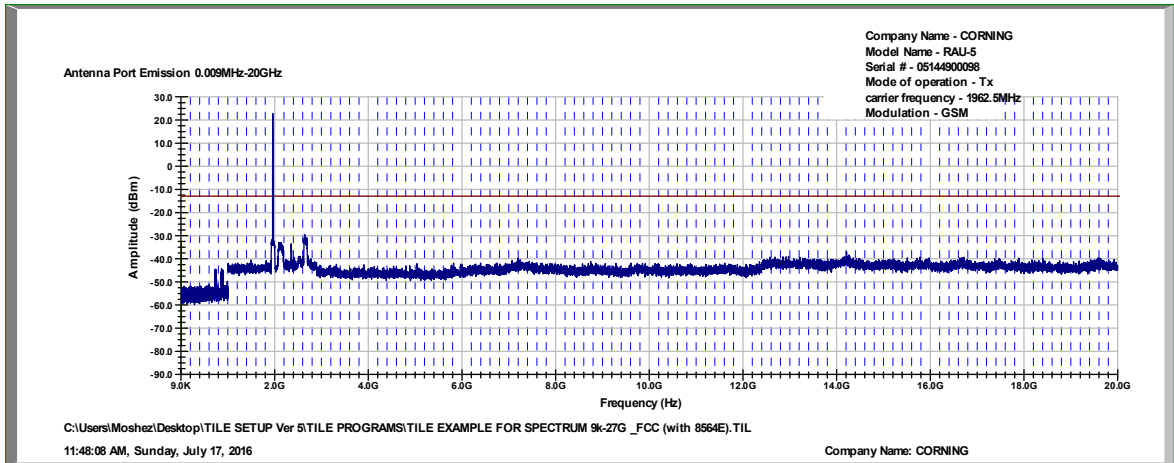

Figure 45. — GSM - 1962.5 MHz

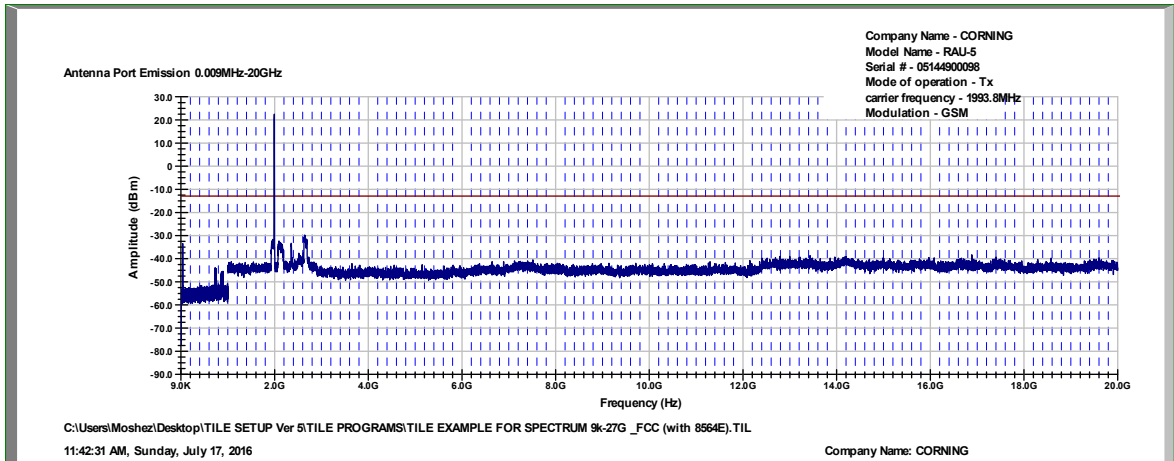

Figure 46. — GSM - 1993.8 MHz

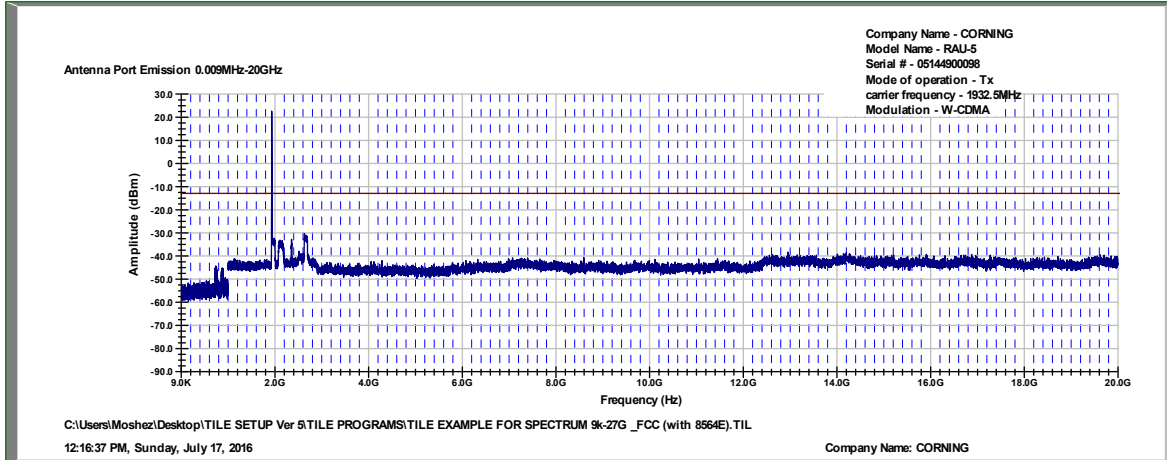

Figure 47. — W-CDMA - 1932.5 MHz

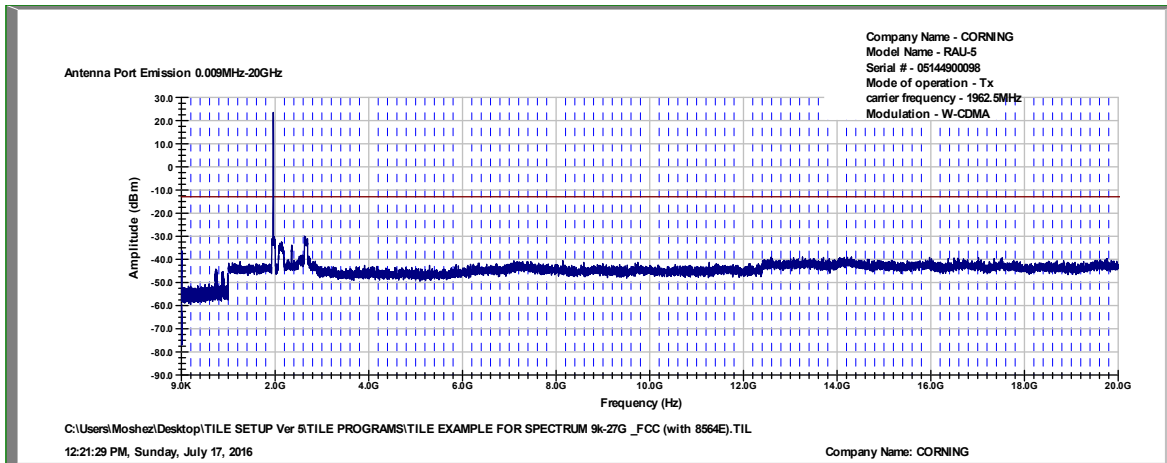

Figure 48. — W-CDMA - 1962.5 MHz

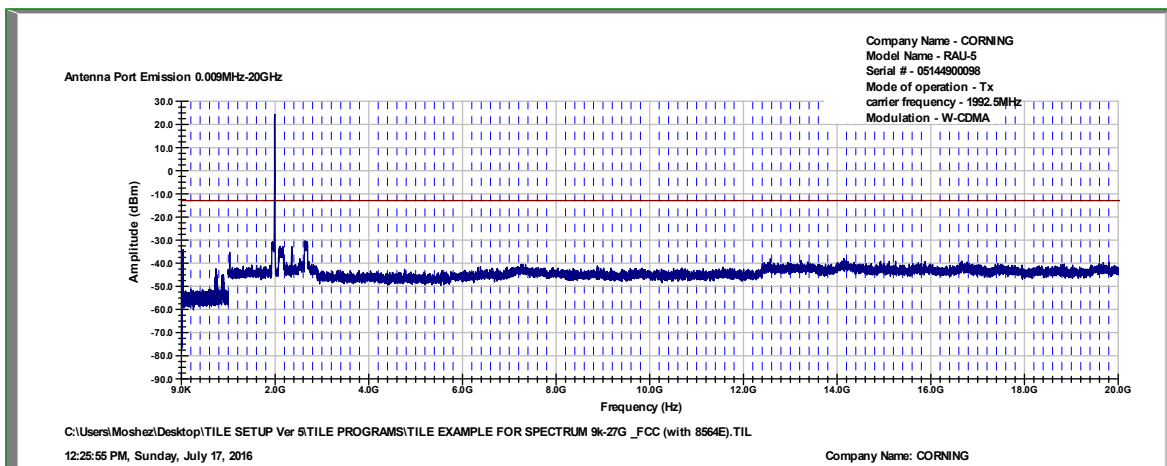

Figure 49. — W-CDMA - 1992.5 MHz



6.5 Test Equipment Used; Out of Band Emission at Antenna Terminals PCS

Instrument	Manufacturer	Model	Serial Number	Calibration	
				Last Calibration Date	Next Calibration Due
EXG Vector Signal Generator	Agilent	N5172B	MY51350584	July 1, 2016	July 1, 2017
Spectrum Analyzer	HP	8592L	3826A01204	March 13, 2016	March 13, 2017
30 dB Attenuator	MCL	BW-S30W5	533	July 5, 2016	July 5, 2017

Figure 50 Test Equipment Used



7. Band Edge Spectrum PCS

7.1 Test Specification

FCC Part 24, Subpart E, Section 238; FCC Part 2.1051

7.2 Test Procedure

(Temperature (22°C)/ Humidity (35%RH))

The E.U.T. antenna terminal was connected to the spectrum analyzer through an external attenuator and an appropriate coaxial cable (31.0 dB).

The spectrum analyzer was set to 100 kHz R.B.W.

7.3 Test Limit

The power of any emission outside of the authorized operating frequency ranges (1930.0-1995.0 MHz) must be attenuated below the transmitting power (P) by a factor of at least $43 + \log(P)$ dB, yielding -13dBm.

7.4 Test Results

Modulation	Operation Frequency	Band Edge Frequency	Reading	Limit	Margin
	(MHz)	(MHz)	(dBm)	(dBm)	(dB)
LTE 64QAM	1935.0	1930.0	-27.4	-13.0	-14.4
	1990.0	1995.0	-24.4	-13.0	-11.4
GSM	1931.2	1930.0	-35.1	-13.0	-22.1
	1993.8	1995.0	-33.1	-13.0	-20.1
W-CDMA	1932.5	1930.0	-18.4	-13.0	-5.4
	1992.5	1995.0	-18.2	-13.0	-5.2

Figure 51 Band Edge Spectrum Results PCS

JUDGEMENT: Passed by 5.2 dB

See additional information in *Figure 52 to Figure 57*.

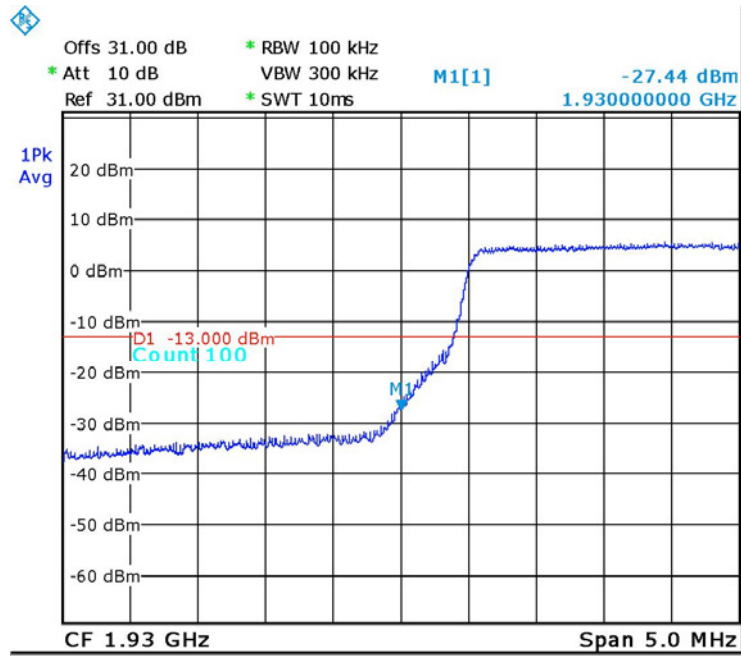

Date: 17.JUL.2016 10:50:45

Figure 52. — LTE 64QAM 1935.0 MHz

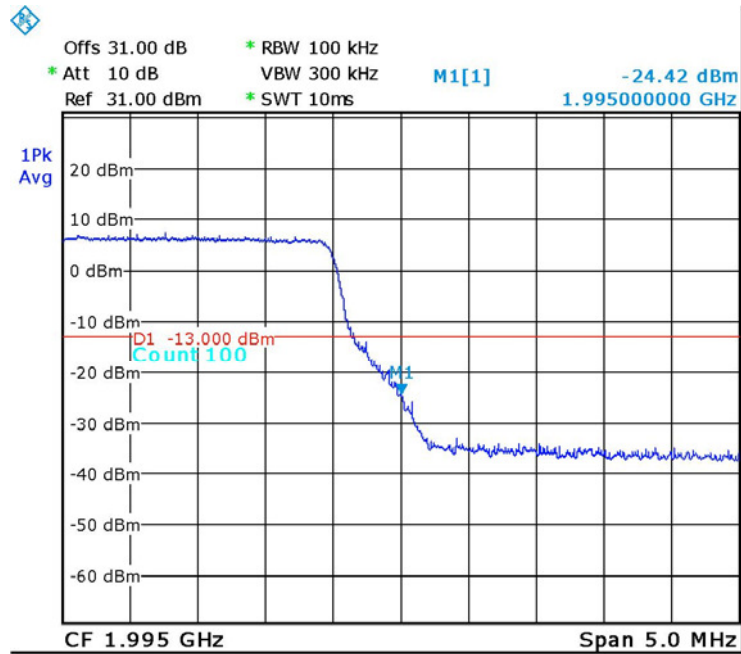

Date: 17.JUL.2016 10:50:12

Figure 53. — LTE 64QAM 1990.0 MHz

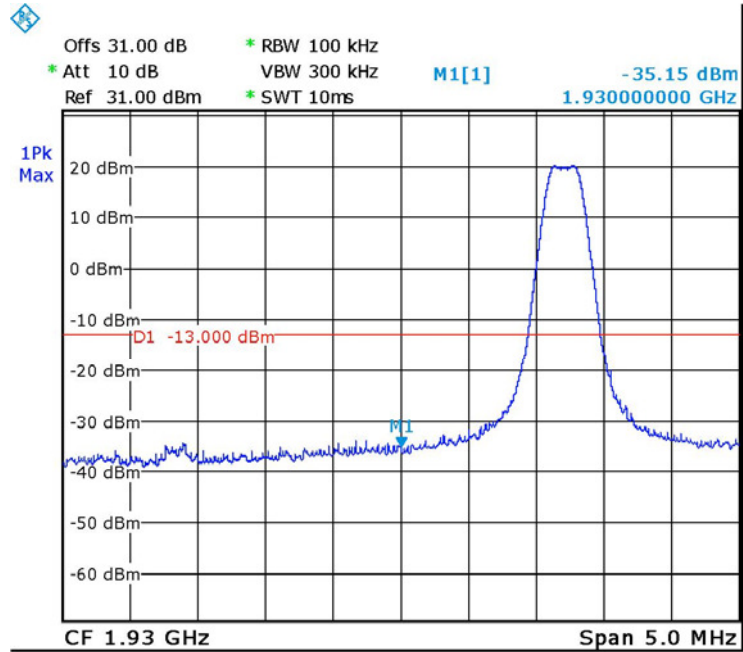

Date: 17.JUL.2016 10:52:08

Figure 54. — GSM - 1931.2 MHz

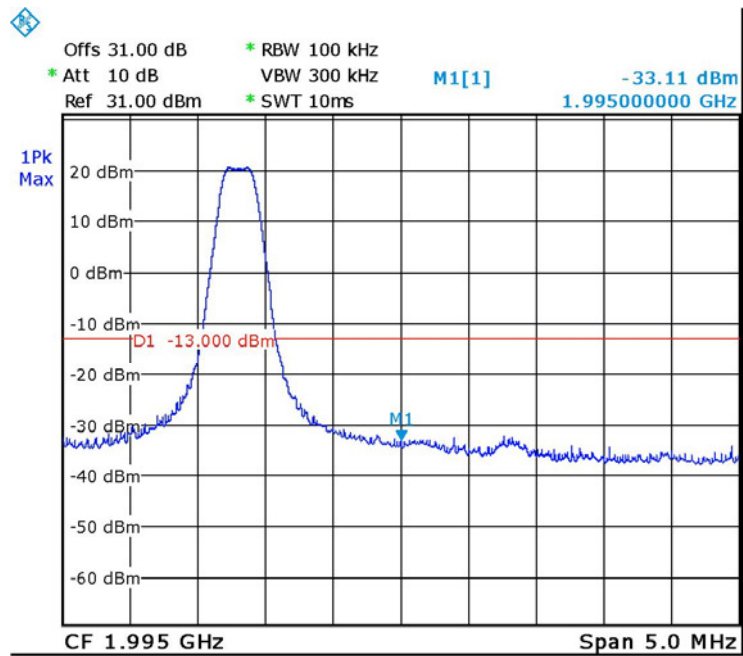

Date: 17.JUL.2016 10:53:13

Figure 55. — GSM - 1993.8 MHz

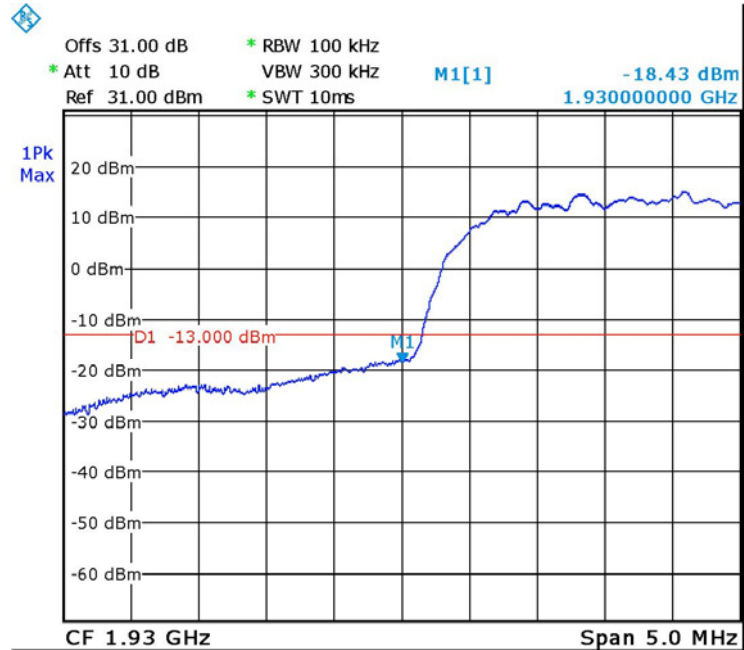

Date: 17.JUL.2016 10:31:33

Figure 56. — W-CDMA - 1932.5 MHz

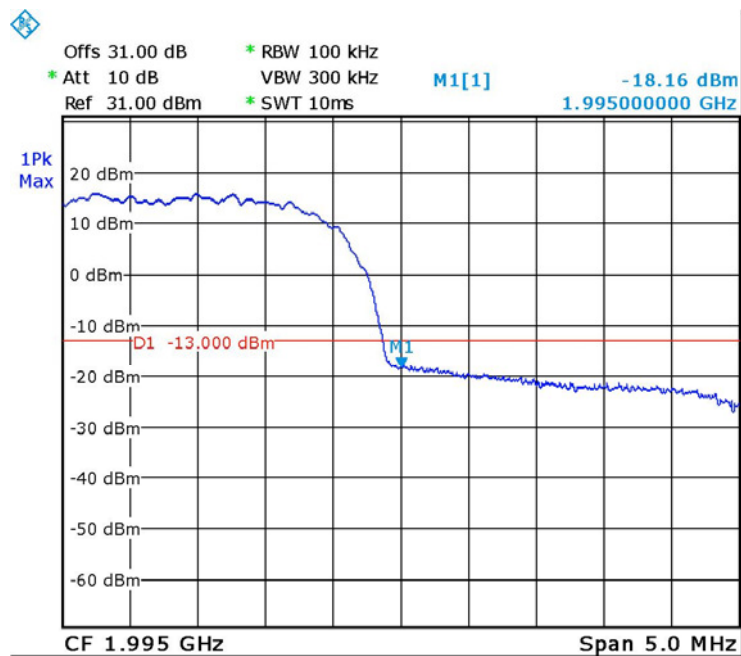

Date: 17.JUL.2016 10:33:17

Figure 57. — W-CDMA - 1992.5 MHz



7.5 Test Equipment Used; Band Edge Spectrum PCS

Instrument	Manufacturer	Model	Serial Number	Calibration	
				Last Calibration Date	Next Calibration Due
Spectrum Analyzer	R&S	FSL6	100194	February 29, 2016	March 1, 2017
Vector Signal Generator	Agilent	N5172B	MY51350584	July 1, 2016	July 1, 2017
30 dB Attenuator	MCL	BW-S30W5	533	July 5, 2016	July 5, 2017

Figure 58 Test Equipment Used



8. Spurious Emissions (Radiated) PCS

8.1 Test Specification

FCC, Part 24, Subpart E Section 238, FCC Part 2.1053

8.2 Test Procedure

(Temperature (23°C)/ Humidity (52%RH))

The test method was based on ANSI/TIA-603-D: 2010, Section 2.2.12 Unwanted Emissions: Radiated Spurious.

For measurements between 0.009MHz-30MHz:

The E.U.T was tested inside the shielded room at a distance of 3 meters and the E.U.T was placed on a non-metallic table, 1.5 meters above the ground. The frequency range 0.009MHz-30MHz was scanned. The readings were maximized by the turntable azimuth between 0-360°, and the antenna polarization. The emissions were measured at a distance of 3 meters.

For measurements between 30.0MHz-1.0GHz:

A preliminary measurement to characterize the E.U.T was performed inside the shielded room at a distance of 3 meters, using peak detection mode and broadband antennas. The preliminary measurements produced a list of the highest emissions. The E.U.T was then transferred to the open site, and placed on a remote-controlled turntable. The E.U.T was placed on a non-metallic table, 0.8 meters above the ground. The frequency range 30.0MHz -1.0GHz was scanned and the list of the highest emissions was verified and updated accordingly.

The readings were maximized by adjusting the antenna height between 1-4 meters, the turntable azimuth between 0-360°, and the antenna polarization.

The emissions were measured at a distance of 3 meters.

For measurements between 1.0GHz-20.0GHz:

The E.U.T was tested inside the shielded room at a distance of 3 meters and the E.U.T was placed on a non-metallic table, 1.5 meters above the ground. The frequency range 1.0GHz -20.0GHz was scanned. The readings were maximized by the turntable azimuth between 0-360°, and the antenna polarization. The emissions were measured at a distance of 3 meters.

The E.U.T. was replaced by a substitution antenna (dipole 30MHz-1GHz, Horn Antenna above 1GHz) driven by a signal generator. The height was readjusted for maximum reading. The signal generator level was adjusted to obtain the same reading on the EMI receiver as in step (a).

The signals observed in step (a) were converted to radiated power using:

$$P_d(\text{dBm}) = P_g(\text{dBm}) - \text{Cable Loss (dB)} + \text{Substitution Antenna Gain (dBd)}$$

P_d = Dipole equivalent power (result).

P_g = Signal generator output level.

A Peak detector was used for this test.

The test was performed in 3 operation frequencies: low, mid and high.

Testing was performed when the RF port was connected to 50 Ω termination.

The table below describe only results with the highest radiation.



8.3 Test Limit

The power of any emission outside of the authorized operating frequency ranges (1930-1995.0MHz) must be attenuated below the transmitting power (P) by a factor of at least $43 + 10 \log (P)$ dB, yielding -13dBm .

8.4 Results Table

Carrier Channel	Freq.	Antenna Pol.	Maximum Peak Level	Signal Generator RF Output	Cable Loss	Antenna Gain	Effective Radiated Power Level	Limit	Margin
(MHz)	(MHz)	(V/H)	(dBμV/m)	(dBm)	(dB)	(dBd)	(dBm)	(dBm)	(dB)
1931.2	3862.4	V	56.1	-43.0	0.5	9.5	-34.0	-13.0	-21.0
	3862.4	H	56.0	-42.6	0.5	9.5	-33.6	-13.0	-20.6
1960.0	3920.0	V	56.1	-43.0	0.5	9.5	-34.0	-13.0	-21.0
	3920.0	H	56.1	-42.6	0.5	9.5	-33.6	-13.0	-20.6
1993.8	3987.6	V	56.3	-43.0	0.5	9.5	-34.0	-13.0	-21.0
	3987.6	H	56.0	-42.6	0.5	9.5	-33.6	-13.0	-20.6

Figure 59 Spurious Emission (Radiated) PCS

JUDGEMENT: Passed by 20.6 dB

The E.U.T met the requirements of the FCC, Part 24, Subpart E, Section 238; FCC Part 2.1053 specifications.



8.5 Test Instrumentation Used, Radiated Measurements

Instrument	Manufacturer	Model	Serial Number	Calibration	
				Last Calibration Date	Next Calibration Due
EMI Receiver	HP	85422E	3906A00276	March 3, 2016	March 3, 2017
RF Filter Section	HP	85420E	3705A00248	March 3, 2016	March 3, 2017
EMI Receiver	R&S	ESCI7	100724	February 29, 2016	March 1, 2017
Spectrum Analyzer	HP	8593EM	3536A00120ADI	March 10, 2016	March 10, 2017
Active Loop Antenna	EMCO	6502	9506-2950	November 5, 2015	November 30, 2016
Antenna Biconical	EMCO	3110B	9912-3337	March 24, 2016	March 24, 2018
Antenna Log Periodic	EMCO	3146	9505-4081	April 23, 2016	April 23, 2017
Horn Antenna 1G-18G	ETS	3115	29845	May 19, 2015	May 19, 2018
Horn Antenna 18G-26G	ARA	SWH-28	1007	March 30, 2014	September 30, 2016
Low Noise Amplifier	Narda	LNA-DBS-0411N313	013	March 1, 2015	September 30, 2016
Low Noise Amplifier	Sophia Wireless	LNA 28-B	232	March 1, 2015	September 30, 2016
MXG Vector Signal Generator	Agilent	N5182A	MY49060440	July 1, 2016	July 1, 2017
Semi Anechoic Civil Chamber	ETS	S81	SL 11643	N/A	N/A
Antenna Mast	ETS	2070-2	-	N/A	N/A
Turntable	ETS	2087	-	N/A	N/A
Mast & Table Controller	ETS/EMCO	2090	9608-1456	N/A	N/A

Figure 60 Test Equipment Used



9. Intermodulation Conducted

9.1 Test Procedure

(Temperature (22°C)/ Humidity (37%RH))

The E.U.T. antenna terminal was connected to the spectrum analyzer through an external attenuator and an appropriate coaxial cable (max loss = 40.0dB). The spectrum analyzer was set to 1 kHz resolution BW for the frequency range 9.0-150.0 kHz, 10 kHz for the frequency range 150 kHz–1.0 MHz, 100 kHz for the frequency range 1.0 MHz – 30 MHz, and 1MHz for the frequency range 30 MHz - 24GHz.

6 input signals were sent simultaneously to the E.U.T. as follows:

LTE band: 742.0 MHz, 0 dBm

CELL&ESMR band: 878.0 MHz, 0 dBm

PCS band: 1962.5 MHz, 0 dBm

AWS band: 2132.5 MHz, 0 dBm

WCS band: 2355.0MHz, 0 dBm

TDD 2.5G band: 2593.0MHz, 0 dBm

The frequency range of 9 kHz – 24.0 GHz was scanned for unwanted signals.

9.2 Test Limit

The power of any emission outside of the authorized operating frequency ranges must be attenuated below the transmitting power (P) by a factor of at least $43 + 10 \log (P)$ dB, yielding -13 dBm.

9.3 Test Results

JUDGEMENT: Passed

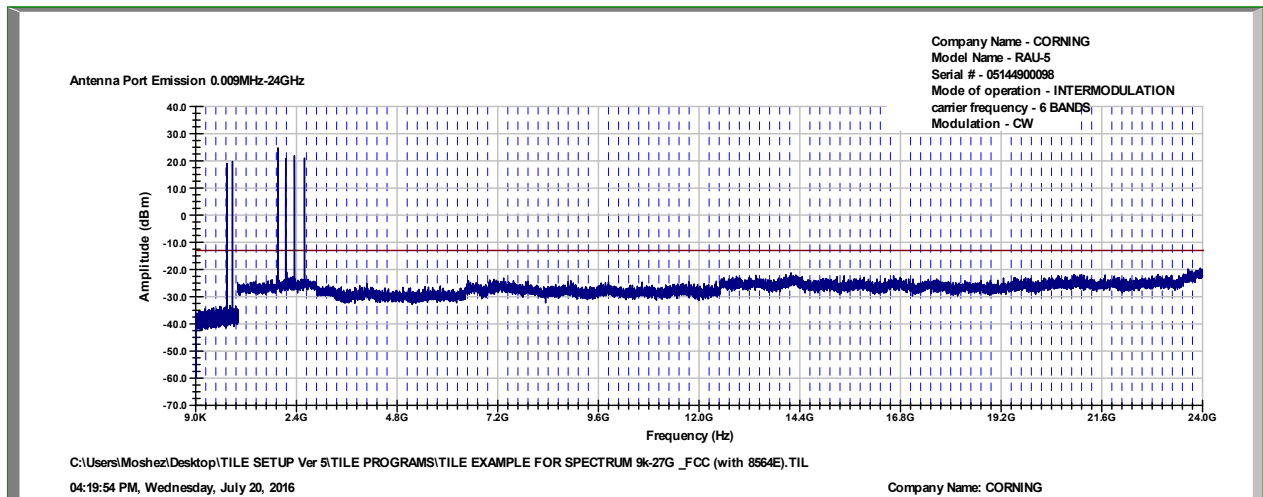

Figure 61 Intermodulation Conducted



9.4 Test Equipment Used; Intermodulation Conducted

Instrument	Manufacturer	Model	Serial Number	Calibration	
				Last Calibration Date	Next Calibration Due
Spectrum Analyzer	HP	8564E	3442A00275	March 10, 2016	March 10, 2017
EXG Vector Signal Generator	Agilent	N5172B	TE4384	July 1, 2016	July 1, 2017
EXG Vector Signal Generator	Agilent	N5172B	MY513500584	July 1, 2016	July 1, 2017
MXG Vector Signal Generator	Agilent	N5182A	MY48180244	July 1, 2016	July 1, 2017
MXG Vector Signal Generator	Agilent	N5182A	MY49060440	July 1, 2016	July 1, 2017
Signal Generator	HP	E4432B	GB40050998	July 1, 2016	July 1, 2017
ESG Vector Signal Generator	Agilent	E4438C	MY45094064	July 1, 2016	July 1, 2017
30 dB Attenuator	MCL	BW-S30W5	533	July 5, 2016	July 5, 2017
6 dB Attenuator	Weinschel Associates	WA 40-6-34	568	July 6, 2016	July 6, 2017

Figure 62 Test Equipment Used



10. Intermodulation Radiated

10.1 Test Procedure

(Temperature (23°C)/ Humidity (47%RH))

The test method was based on ANSI/TIA-603-C: 2004, Section 2.2.12 Unwanted Emissions: Radiated Spurious.

For measurements between 0.009MHz-30MHz:

The E.U.T was tested inside the shielded room at a distance of 3 meters and the E.U.T was placed on a non-metallic table, 1.5 meters above the ground. The frequency range 0.009MHz-30MHz was scanned. The readings were maximized by the turntable azimuth between 0-360°, and the antenna polarization. The emissions were measured at a distance of 3 meters.

For measurements between 30.0MHz-1.0GHz:

A preliminary measurement to characterize the E.U.T was performed inside the shielded room at a distance of 3 meters, using peak detection mode and broadband antennas. The preliminary measurements produced a list of the highest emissions. The E.U.T was then transferred to the open site, and placed on a remote-controlled turntable. The E.U.T was placed on a non-metallic table, 0.8 meters above the ground. The frequency range 30.0MHz -1.0GHz was scanned and the list of the highest emissions was verified and updated accordingly. The readings were maximized by adjusting the antenna height between 1-4 meters, the turntable azimuth between 0-360°, and the antenna polarization. The emissions were measured at a distance of 3 meters.

For measurements between 1.0GHz-24.0GHz:

The E.U.T was tested inside the shielded room at a distance of 3 meters and the E.U.T was placed on a non-metallic table, 1.5 meters above the ground. The frequency range 1.0GHz -24.0GHz was scanned. The readings were maximized by the turntable azimuth between 0-360°, and the antenna polarization. The emissions were measured at a distance of 3 meters.

The E.U.T. was replaced by a substitution antenna (dipole 30MHz-1GHz, Horn Antenna above 1GHz) driven by a signal generator. The height was readjusted for maximum reading. The signal generator level was adjusted to obtain the same reading on the EMI receiver as in step (a).

The signals observed in step (a) were converted to radiated power using:

$$P_d(\text{dBm}) = P_g(\text{dBm}) - \text{Cable Loss (dB)} + \text{Substitution Antenna Gain (dBd)}$$

P_d = Dipole equivalent power (result).

P_g = Signal generator output level.

6 input signals were sent simultaneously to the E.U.T. as follows:

LTE band: 742.0 MHz, 0 dBm

CELL band: 878.0 MHz, 0 dBm

PCS band: 1962.5 MHz, 0 dBm

AWS band: 2132.5 MHz, 0 dBm

WCS band: 2355.0MHz, 0 dBm

TDD 2.5G band: 2593.0MHz, 0 dBm



A Peak detector was used for this test.

The test was performed in 3 operation frequencies: low, mid and high.

Testing was performed when the RF port was connected to 50 Ω termination.

The table below describe only results with the highest radiation.

10.2 Test Limit

The power of any emission outside of the authorized operating frequency ranges (728-758; 869-894; 1930-1990; 2110-2155 MHz; 2350-2360MHz) must be attenuated below the transmitting power (P) by a factor of at least $43 + 10 \log (P)$ dB, yielding -13dBm .

10.3 Test Results

JUDGEMENT: Passed

For additional information see *Figure 63*.



Freq.	Antenna Pol.	Maximum Peak Level	Signal Generator RF Output	Cable Loss	Antenna Gain	Effective Radiated Power Level	Limit	Margin
(MHz)	(V/H)	(dBμV/m)	(dBm)	(dB)	(dBd)	(dBm)	(dBm)	(dB)
1792.5	V	51.9	-48.7	0.5	7.0	-42.2	-13.0	-29.2
1792.5	H	52.5	-47.5	0.5	7.0	-41.0	-13.0	-28.0
2219.0	V	54.6	-46.1	0.5	7.0	-39.6	-13.0	-26.6
2219.0	H	54.5	-45.5	0.5	7.0	-39.0	-13.0	-26.0
3223.5	V	56.1	-48.8	0.5	10.0	-39.3	-13.0	-26.3
3223.5	H	56.1	-48.4	0.5	10.0	-38.9	-13.0	-25.9
3854.0	V	56.3	-42.8	0.5	9.5	-33.8	-13.0	-20.8
3854.0	H	56.4	-42.3	0.5	9.5	-33.3	-13.0	-20.3
3978.5	V	56.3	-42.8	0.5	9.5	-33.8	-13.0	-20.8
3978.5	H	56.3	-42.3	0.5	9.5	-33.3	-13.0	-20.3
4104.0	V	56.3	-42.8	0.5	9.5	-33.8	-13.0	-20.8
4104.0	H	56.2	-42.3	0.5	9.5	-33.3	-13.0	-20.3
4201.0	V	56.4	-42.6	0.5	9.5	-33.6	-13.0	-20.6
4201.0	H	56.5	-42.3	0.5	9.5	-33.3	-13.0	-20.3
4308.0	V	56.2	-42.6	0.5	9.5	-33.6	-13.0	-20.6
4308.0	H	56.4	-42.3	0.5	9.5	-33.3	-13.0	-20.3
4439.0	V	56.3	-42.8	0.5	9.5	-33.8	-13.0	-20.8
4439.0	H	56.4	-42.3	0.5	9.5	-33.3	-13.0	-20.3
5445.0	V	57.1	-46.2	0.5	10.8	-35.9	-13.0	-22.9
5445.0	H	57.0	-45.0	0.5	10.8	-34.7	-13.0	-21.7

Figure 63 Intermodulation Radiated Results



10.4 Test Instrumentation Used; Radiated Measurements Intermodulation

Instrument	Manufacturer	Model	Serial Number	Calibration	
				Last Calibration Date	Next Calibration Due
EMI Receiver	HP	85422E	3906A00276	March 3, 2016	March 3, 2017
RF Filter Section	HP	85420E	3705A00248	March 3, 2016	March 3, 2017
EMI Receiver	R&S	ESCI7	100724	February 29, 2016	March 1, 2017
Spectrum Analyzer	HP	8593EM	3536A00120ADI	March 10, 2016	March 10, 2017
Active Loop Antenna	EMCO	6502	9506-2950	November 5, 2015	November 30, 2016
Antenna Biconical	EMCO	3110B	9912-3337	March 24, 2016	March 24, 2018
Antenna Log Periodic	EMCO	3146	9505-4081	April 23, 2016	April 23, 2017
Horn Antenna 1G-18G	ETS	3115	29845	May 19, 2015	May 19, 2018
Horn Antenna 18G-26G	ARA	SWH-28	1007	March 30, 2014	September 30, 2016
Low Noise Amplifier	Narda	LNA-DBS-0411N313	013	March 1, 2015	September 30, 2016
Low Noise Amplifier	Sophia Wireless	LNA 28-B	232	March 1, 2015	September 30, 2016
Signal Generator	Marconi	2022D	119196015	March 1, 2016	March 1, 2017
Signal Generator	HP	8648C	3623A04126	February 29, 2016	March 1, 2017
Signal Generator	HP	ESG-4000A/E4422A	US36220118	February 29, 2016	March 1, 2017
MXG Vector Signal Generator	Agilent	N5182A	MY49060440	July 1, 2016	July 1, 2017
ESG Vector Signal Generator	Agilent	E4438C	MY45094064	July 1, 2016	July 1, 2017
Signal Generator	Agilent	E4432B	GB40050998	July 1, 2016	July 1, 2017
Semi Anechoic Civil Chamber	ETS	S81	SL 11643	N/A	N/A
Antenna Mast	ETS	2070-2	-	N/A	N/A
Turntable	ETS	2087	-	N/A	N/A
Mast & Table Controller	ETS/EMCO	2090	9608-1456	N/A	N/A

Figure 64 Test Equipment Used



11. Out-of-Band Rejection (PCS)

11.1 Test Specification

KDB 935210 D05 v01r01, Section 3.3

11.2 Test Procedure

(Temperature (21°C)/ Humidity (35%RH))

The E.U.T. antenna terminal was connected to the spectrum analyzer through an external attenuator and an appropriate coaxial cable (max Loss= 31.0 dB).

The signal and spectrum analyzer frequency range was set to $\pm 250\%$ of the passband, Dwell time set to approximately 10msec.

RBW was set between 1% to 5% of the E.U.T passband and VBW set to $\geq 3 \cdot RBW$.

11.3 Test Limit

N/A

11.4 Test Results

JUDGEMENT: Passed

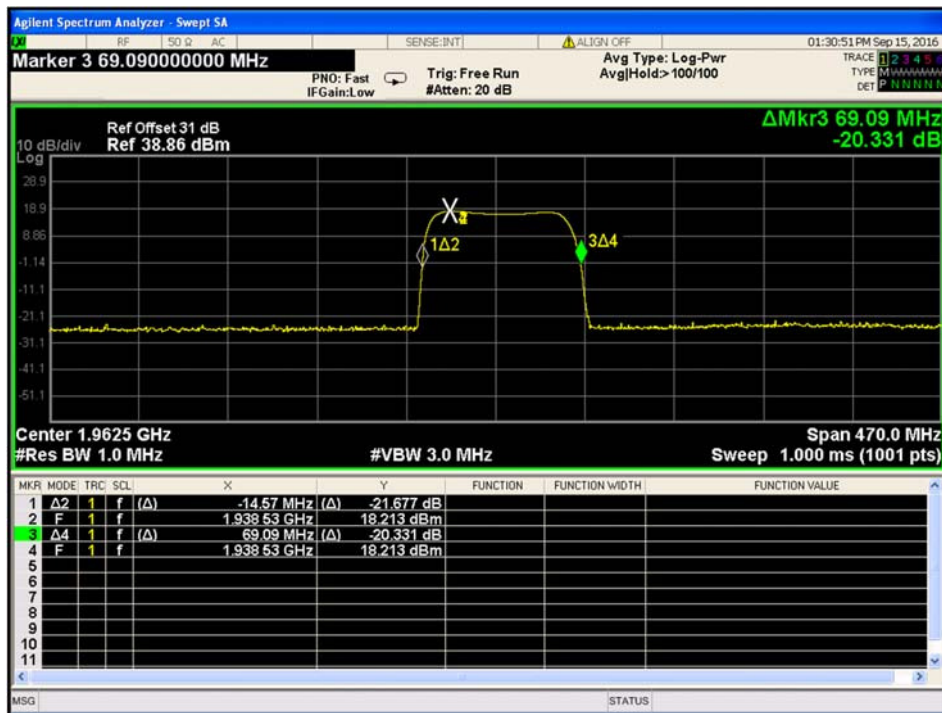

Figure 65. — Out-of-Band Rejection Plot



11.5 Test Equipment Used; Out-of-Band Rejection

Instrument	Manufacturer	Model	Serial Number	Calibration	
				Last Calibration Date	Next Calibration Date
EXA Spectrum Analyzer	Agilent	N9010A	MY48030391	March 16, 2016	March 16, 2018
EXG Vector Signal Generator	Agilent	N5172B	MY49060440	November 11, 2014	November 19, 2017
30 dB Attenuator	MCL	BW-S30W5	533	July 5, 2016	July 15, 2017

Figure 66 Test Equipment Used



12. APPENDIX A - CORRECTION FACTORS

12.1 Correction factors for *RF OATS Cable 35m* *ITL #1784*

Frequency (MHz)	Cable loss (dB)
10.0	0.3
20.0	0.2
50.0	-0.1
100.0	-0.6
200.0	-1.2
500.0	-2.3
1000.0	-3.6



12.2 Correction factors for RF OATS Cable 10m
ITL #1794

Frequency(MHz)	Cable loss(dB)
10.0	-0.3
20.0	-0.3
50.0	-0.5
100.0	-0.7
200.0	-1.1
500.0	-1.8
1000.0	-2.7



12.3 Correction factors for

**Horn Antenna
Model: SWH-28
at 1 meter range.**

FREQUENCY (GHz)	AFE (dB /m)	Gain (dB1)
18.0	40.3	16.1
19.0	40.3	16.3
20.0	40.3	16.1
21.0	40.3	16.3
22.0	40.4	16.8
23.0	40.5	16.4
24.0	40.5	16.6
25.0	40.5	16.7
26.0	40.6	16.4



12.4 Correction factors for Horn ANTENNA
Model: 3115
Antenna serial number: 29845
3 meter range

f(GHz)	AF(dB/m)	GA(dB)
0.75	25	3
1G	23.5	7
1.5G	26	8
2G	29	7
2.5G	27.5	10
3G	30	10
3.5G	31.5	10
4G	32.5	9.5
4.5G	32.5	10.5
5G	33	10.5
5.5G	35	10.5
6G	36.5	9.5
6.5G	36.5	10
7G	37.5	10
7.5G	37.5	10
8G	37.5	11
8.5G	38	11
9G	37.5	11.5
9.5G	38	11.5
10G	38.5	11.5
10.5G	38.5	12
11G	38.5	12.5
11.5G	38.5	13
12G	38	13.5
12.5G	38.5	13
13G	40	12
13.5G	41	12
14G	40	13
14.5G	39	14
15G	38	15.5
15.5G	37.5	16
16G	37.5	16
16.5G	39	15
17G	40	15
17.5G	42	13.5
18G	42.5	13



**12.5 Correction factors for Log Periodic Antenna
EMCO, Model 3146,
Serial #9505-4081**

Frequency [MHz]	AF [dB/m]
200.0	11.47
250.0	12.06
300.0	14.77
400.0	15.77
500.0	18.01
600.0	18.84
700.0	20.93
800.0	21.27
900.0	22.44
1000.0	24.10



**12.6 Correction factors for Biconical Antenna
EMCO, Model 3110B,
Serial #9912-3337**

Frequency [MHz]	AF [dB/m]
30.0	14.18
35.0	13.95
40.0	12.84
45.0	11.23
50.0	11.10
60.0	10.39
70.0	9.34
80.0	9.02
90.0	9.31
100.0	8.95
120.0	11.53
140.0	12.20
160.0	12.56
180.0	13.49
200.0	15.27



12.7 Correction factors for ACTIVE LOOP ANTENNA
Model 6502
S/N 9506-2950

f(MHz)	MAF(dBs/m)	AF(dB/m)
0.01	-33.1	18.4
0.02	-37.2	14.3
0.03	-38.2	13.3
0.05	-39.8	11.7
0.1	-40.1	11.4
0.2	-40.3	11.2
0.3	-40.3	11.2
0.5	-40.3	11.2
0.7	-40.3	11.2
1	-40.1	11.4
2	-40	11.5
3	-40	11.5
4	-40.1	11.4
5	-40.2	11.3
6	-40.4	11.1
7	-40.4	11.1
8	-40.4	11.1
9	-40.5	11
10	-40.5	11
20	-41.5	10
30	-43.5	8