



**DATE: 11 January 2017**

**I.T.L. (PRODUCT TESTING) LTD.  
FCC Radio Test Report**

for

**Corning Optical Communication Wireless**

**Equipment under test:**

**ONE- Optical Network Evolution DAS**

**RAU-4 Remote Antenna Unit  
AWS, CELL, LTE, PCS  
(AWS Section)**

Tested by:

M. Zohar

Approved by:

D. Shidlowsky

This report must not be reproduced, except in full, without the written permission of I.T.L. (Product Testing) Ltd.

This report relates only to items tested.



## Measurement/Technical Report for Corning Optical Communication Wireless

### ONE- Optical Network Evolution DAS RAU-4 Remote Antenna Unit

**FCC ID: OJF1C85P19L70A17**

This report concerns: Original Grant:  
Class II change: X  
Class I change:

Equipment type: Part 20 Industrial Booster (CMRS)

Limits used: 47CFR Parts 2, 27

Measurement procedure used is KDB 971168 D03 v01 and KDB 935210 D05 v01r01.

Substitution Method used as in ANSI/TIA-603-D: 2010.

Application for Certification  
prepared by:  
R. Pinchuck  
ITL (Product Testing) Ltd.  
1 Bat Sheva St.  
Lod 7120101  
Israel  
e-mail [rpinchuck@itl.co.il](mailto:rpinchuck@itl.co.il)

Applicant for this device:  
(different from "prepared by")  
Habib Riazi  
Corning Optical Communication Wireless  
13221 Woodland Park Rd., Suite #400  
Herndon, VA. 20171  
U.S.A.  
Tel: +1-541-758-2880  
Fax: +1-703-848-0260  
e-mail: [RiaziH@corning.com](mailto:RiaziH@corning.com)



# TABLE OF CONTENTS

<b>1.</b>	<b>GENERAL INFORMATION</b> -----	<b>5</b>
1.1	Administrative Information .....	5
1.2	List of Accreditations .....	6
1.3	Product Description .....	7
1.4	Test Methodology .....	7
1.5	Test Facility .....	7
1.6	Measurement Uncertainty.....	7
<b>2.</b>	<b>SYSTEM TEST CONFIGURATION</b> -----	<b>8</b>
2.1	Justification.....	8
2.2	EUT Exercise Software .....	8
2.3	Special Accessories .....	8
2.4	Equipment Modifications .....	8
2.5	Configuration of Tested System .....	9
<b>3.</b>	<b>TEST SET-UP PHOTOS</b> -----	<b>11</b>
<b>4.</b>	<b>RF POWER OUTPUT AWS</b> -----	<b>15</b>
4.1	Test Specification .....	15
4.2	Test Procedure .....	15
4.3	Test Limit.....	15
4.4	Test Results .....	15
4.5	Test Equipment Used; RF Power Output AWS.....	21
<b>5.</b>	<b>OCCUPIED BANDWIDTH AWS</b> -----	<b>22</b>
5.1	Test Specification .....	22
5.2	Test Procedure .....	22
5.3	Test Limit.....	22
5.4	Test Results .....	22
5.5	Test Equipment Used; Occupied Bandwidth.....	32
<b>6.</b>	<b>SPURIOUS EMISSIONS AT ANTENNA TERMINALS AWS</b> -----	<b>33</b>
6.1	Test Specification .....	33
6.2	Test Procedure .....	33
6.3	Test Limit.....	33
6.4	Test Results .....	33
6.5	Test Equipment Used; Spurious Emissions at Antenna Terminals AWS .....	37
<b>7.</b>	<b>BAND EDGE SPECTRUM AWS</b> -----	<b>38</b>
7.1	Test Specification .....	38
7.2	Test Procedure .....	38
7.3	Test Limit.....	38
7.4	Test Results .....	38
7.5	Test Equipment Used; Band Edge Spectrum AWS .....	42
<b>8.</b>	<b>SPURIOUS RADIATED EMISSION AWS</b> -----	<b>43</b>
8.1	Test Specification .....	43
8.2	Test Procedure .....	43
8.3	Test Limit.....	44
8.4	Test Results .....	44
8.5	Test Instrumentation Used, Radiated Measurements AWS.....	45
<b>9.</b>	<b>INTERMODULATION CONDUCTED</b> -----	<b>46</b>
9.1	Test Procedure .....	46
9.2	Test Limit.....	46
9.3	Test Results .....	46
9.4	Test Equipment Used; Intermodulation Conducted .....	47
<b>10.</b>	<b>INTERMODULATION RADIATED</b> -----	<b>48</b>
10.1	Test Procedure .....	48
10.2	Test Limit.....	49
10.3	Test Results .....	49
10.4	Test Instrumentation Used; Radiated Measurements Intermodulation.....	51



<b>11. OUT-OF-BAND REJECTION (AWS)</b> .....	<b>52</b>
11.1 Test Specification .....	52
11.2 Test Procedure .....	52
11.3 Test Limit.....	52
11.4 Test Results .....	52
11.5 Test Equipment Used; Out-of-Band Rejection .....	53
<b>12. APPENDIX A - CORRECTION FACTORS</b> .....	<b>54</b>
12.1 Correction factors for RF OATS Cable 35m.....	54
12.2 Correction factors for RF OATS Cable 10m.....	55
12.3 Correction factors for RF CABLE for Semi Anechoic Chamber .....	56
12.4 Correction factors for Horn Antenna .....	57
12.5 Correction factors for Horn ANTENNA .....	58
12.6 Correction factors for Log Periodic Antenna .....	59
12.7 Correction factors for Biconical Antenna.....	60
12.8 Correction factors for ACTIVE LOOP ANTENNA .....	61



# 1. General Information

## 1.1 Administrative Information

Manufacturer: Corning Optical Communication  
Wireless

Manufacturer's Address: 13221 Woodland Park Rd., Suite #400  
Herndon, VA. 20171  
U.S.A.  
Tel: +1-541-758-2880  
Fax: +1-703-848-0260

Manufacturer's Representative: Habib Riazi

Equipment Under Test (E.U.T): ONE- Optical Network Evolution DAS

Equipment Model No.: RAU-4 Remote Antenna Unit

Equipment Serial No.: 05143500012

Date of Receipt of E.U.T: July 17, 2016

Start of Test: July 18, 2016

End of Test: September 15, 2016

Test Laboratory Location: I.T.L (Product Testing) Ltd.  
1 Batsheva St,  
Lod,  
Israel 7116002

Test Specifications: FCC Parts 2; 27



## **1.2 List of Accreditations**

The EMC laboratory of I.T.L. is accredited by/registered with the following bodies:

1. The American Association for Laboratory Accreditation (A2LA) (U.S.A.), Certificate No. 1152.01.
2. The Federal Communications Commission (FCC) (U.S.A.), FCC Designation Number is IL1005.
3. The Israel Ministry of the Environment (Israel), Registration No. 1104/01.
4. The Voluntary Control Council for Interference by Information Technology Equipment (VCCI) (Japan), Registration Numbers: C-3006, R-2729, T-1877, G-245.
5. Industry Canada (Canada), IC File No.: 46405-4025; Site No. IC 4025A-1, IC 4025A-2.

I.T.L. Product Testing Ltd. is accredited by the American Association for Laboratory Accreditation (A2LA) and the results shown in this test report have been determined in accordance with I.T.L.'s terms of accreditation unless stated otherwise in the report.



### **1.3 Product Description**

The Optical Network Platform (ONE™) by Corning provides a flexible in-building RF and network digital coverage solution based on a fiber optic transport backbone.

The fiber-optics infrastructure is easily deployable via a wide range of pre-terminated composite cables and advanced end-to-end equipment. Easy to design, Plug and Play™ connectors, significantly reduce installation cost and deployment time.

The ONE™ solution is an ideal fit for large, high-rise or campus-style deployments. It generates significant CAPEX savings and OPEX savings through the use of user configurable sectorization and an infrastructure that is simple to deploy and efficient in usage.

Dynamic sectorization management allows precise service distribution control to meet changing density needs, and provides further savings by enabling sharing of equipment at various levels for service providers.

Radio source agnostic, remote units can be used as network extenders. Ethernet capability with dedicated fiber link for Wi-Fi offload brings a higher level of granularity and support for devices and applications with very high speed requirements.

### **1.4 Test Methodology**

Both conducted and radiated testing were performed according to the procedures in KDB 971168 D03 v01, KDB 935210 D05 and ANSI/TIA 603-D: 2010. Radiated testing was performed at an antenna to EUT distance of 3 meters.

### **1.5 Test Facility**

Both conducted and radiated emissions tests were performed at I.T.L.'s testing facility in Lod, Israel. I.T.L.'s EMC Laboratory is accredited by A2LA, certificate No. 1152.01 and its FCC Designation Number is IL1005.

### **1.6 Measurement Uncertainty**

Conducted Emission (CISPR 11, EN 55011, CISPR 22, EN 55022, ANSI C63.4)

0.15 – 30 MHz:

Expanded Uncertainty (95% Confidence, K=2):

± 3.44 dB

Radiated Emission (CISPR 11, EN 55011, CISPR 22, EN 55022, ANSI C63.4) for open site 30-1000MHz:

Expanded Uncertainty (95% Confidence, K=2):

± 4.98 dB



## 2. System Test Configuration

### 2.1 *Justification*

The E.U.T. was originally FCC certified on 9/13/2013 under FCC ID: OJF1C85P19L70A17.

A C2PC Grant was issued on 5/5/2014 to remove the limited waiver issued by the FCC.

The E.U.T. is part of a booster system operated with the RXU certified under FCC ID: OJF1RXU.

No changes have been made to the E.U.T.

The C2PC change is to allow the E.U.T. to operate as part of a booster system with the new RXU2325 certified under FCC ID: OJF1RXUN.

The E.U.T. has been fully tested with the RXU2325 and results presented in the four reports (for bands AWS, CELL, PCS & LTE) submitted with this application.

### 2.2 *EUT Exercise Software*

HCM\_2.2 Build23  
ACM\_2a00\_22\_11.bin  
RMM\_5a00\_22\_02. bin  
OIM\_7a03\_22\_05. bin  
RAU\_8a03\_22\_07

### 2.3 *Special Accessories*

No special accessories were needed in order to achieve compliance.

### 2.4 *Equipment Modifications*

No modifications were necessary in order to achieve compliance.



## 2.5 Configuration of Tested System

Product Name	ONE Wireless Platform
Model Name	RAU-4
Working voltage	48.0VDC
Mode of operation	Industrial Booster for AWS band
Modulations	WCDMA, LTE(64QAM), GSM
Assigned Frequency Range	2110.0MHz-2155.0MHz
Transmit power	~18.0dBm
Antenna Gain	12.5dBi
DATA rate	N/A
Modulation BW	0.5MHz(GSM), 5MHz(WCDMA); 10MHz(LTE)

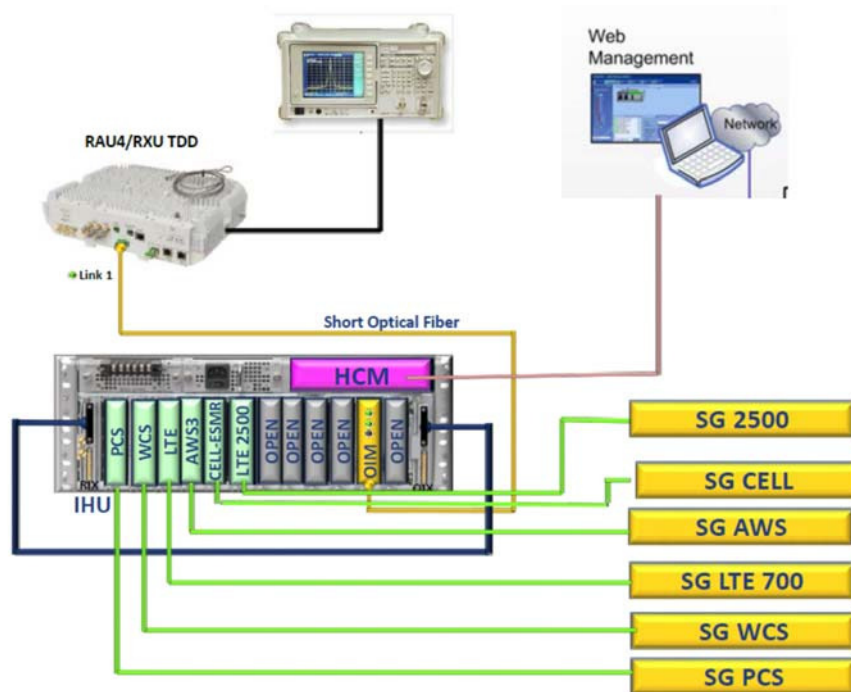

Figure 1. Conducted Test Set-Up

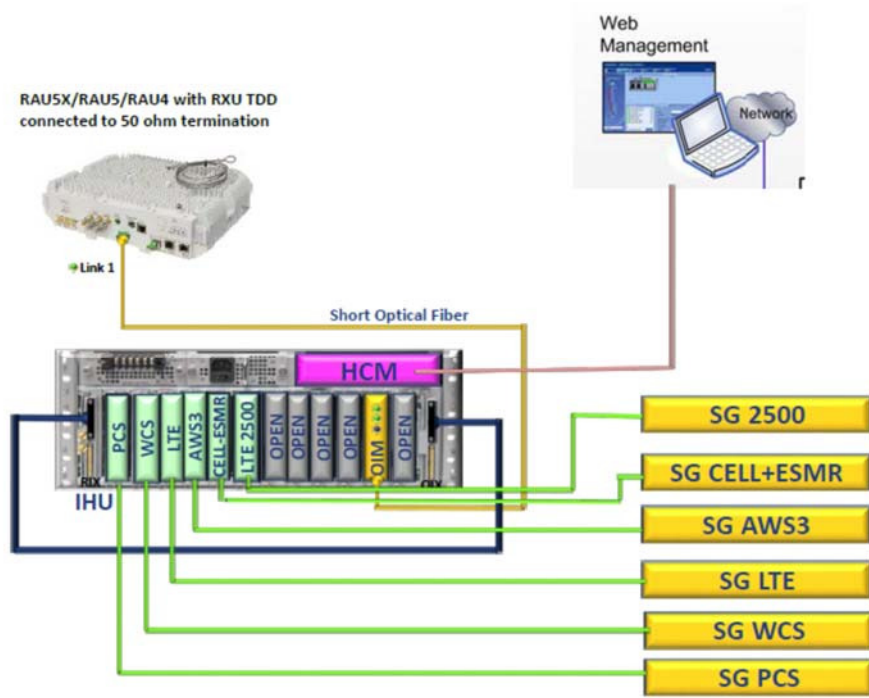

Figure 2. Radiated Test Set-Up

### 3. Test Set-Up Photos

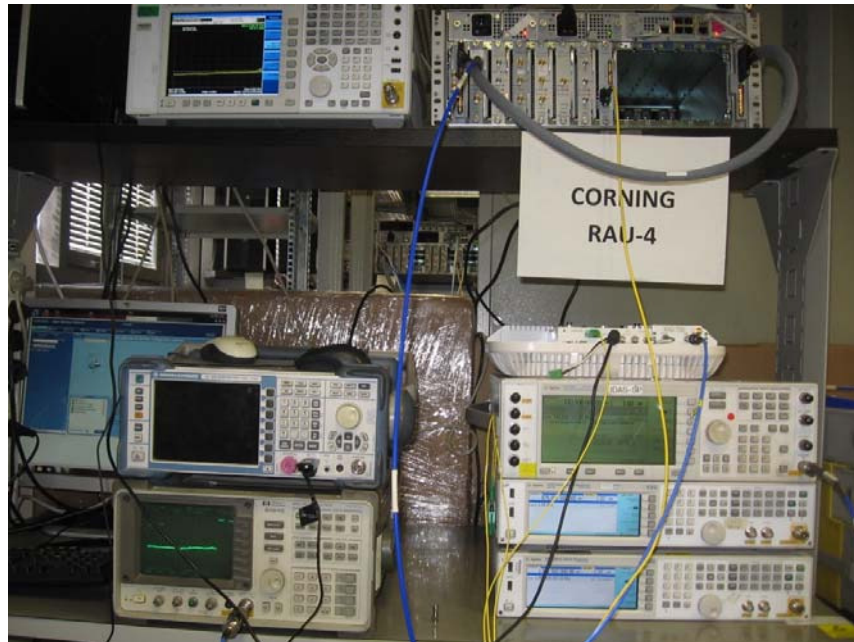

Figure 3. Conducted Emission from Antenna Ports Test



Figure 4. Radiated Emission Test



**Figure 5. Radiated Emission Test**

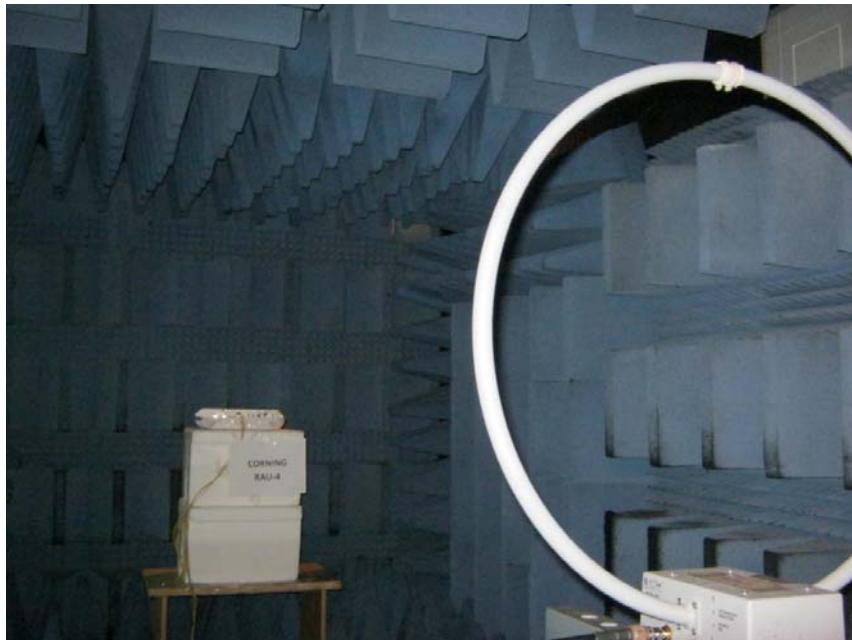

**Figure 6. Radiated Emission Test**



**Figure 7. Radiated Emission Test**



**Figure 8. Radiated Emission Test**

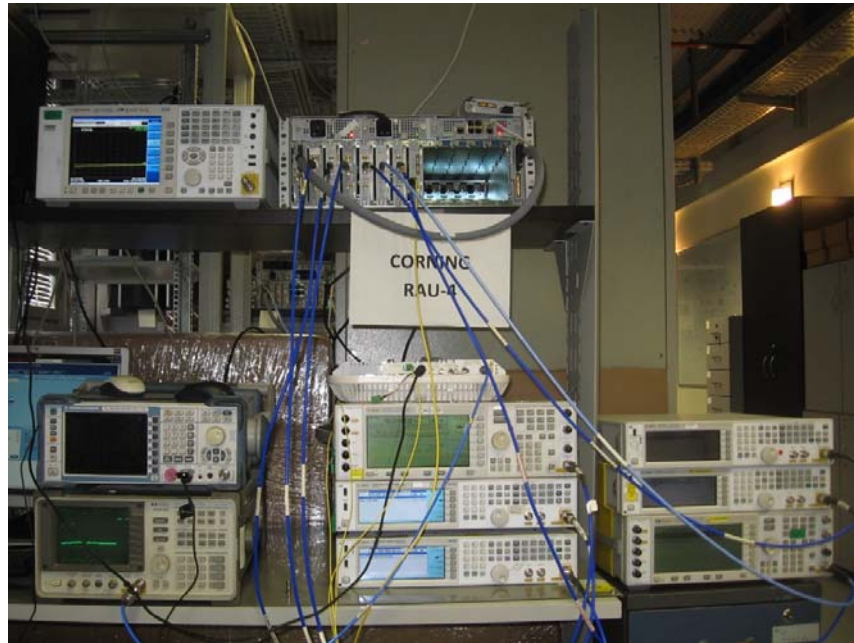

**Figure 9. Intermodulation Conducted Test**



## 4. RF Power Output AWS

### 4.1 Test Specification

FCC Part 27, Subpart C, Section 27.50(d)

### 4.2 Test Procedure

(Temperature (23°C)/ Humidity (39%RH))

The E.U.T. antenna terminal was connected to the Spectrum Analyzer through an external attenuator (31.0 dB) and an appropriate coaxial cable. Special attention was taken to prevent Spectrum Analyzer RF input overload.

### 4.3 Test Limit

The power limit is 1640W (62.1 dBm)

### 4.4 Test Results

Modulation	Operation Frequency	Reading	Antenna Gain	EIRP	Limit	Margin
	(MHz)	(dBm)	(dBi)	(dBm)	(dBm)	(dB)
GSM	2111.2	19.8	12.5	32.3	62.1	-29.8
	2132.5	18.8	12.5	31.3	62.1	-30.8
	2153.8	18.6	12.5	31.1	62.1	-31.0
LTE 64QAM	2115.0	18.9	12.5	31.4	62.1	-30.7
	2132.5	19.5	12.5	32.0	62.1	-30.1
	2150.0	19.6	12.5	32.1	62.1	-30.0
WCDMA	2112.5	19.1	12.5	31.6	62.1	-30.5
	2132.5	19.3	12.5	31.8	62.1	-30.3
	2152.5	19.4	12.5	31.9	62.1	-30.2

Figure 10 RF Power Output AWS

See additional information in *Figure 11* to *Figure 19*.

JUDGEMENT: Passed

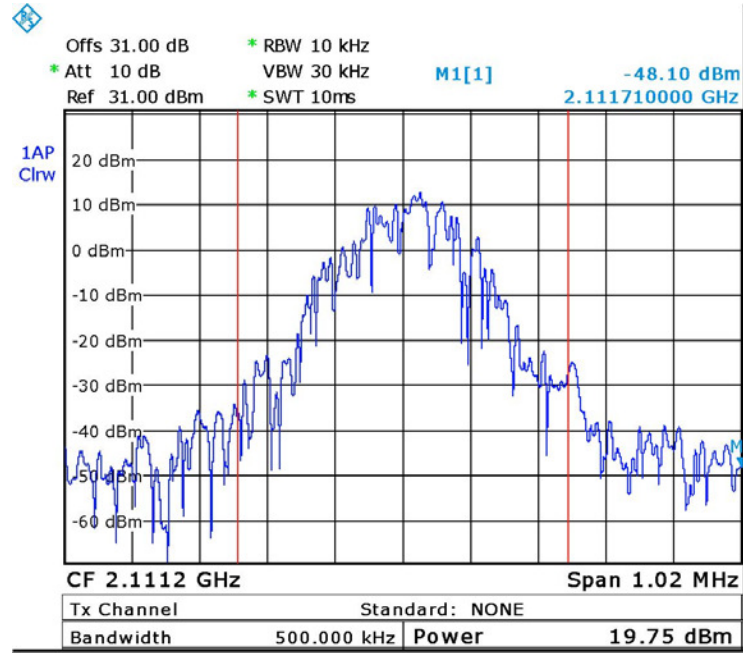

Date: 18.JUL.2016 09:19:33

Figure 11. — GSM (2111.2 MHz)

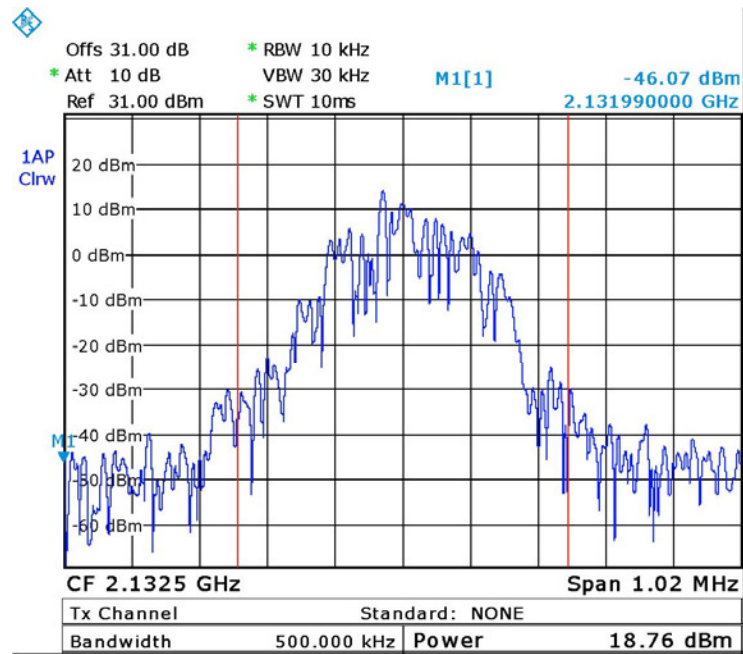

Date: 18.JUL.2016 09:22:06

Figure 12. — GSM (2132.50MHz)



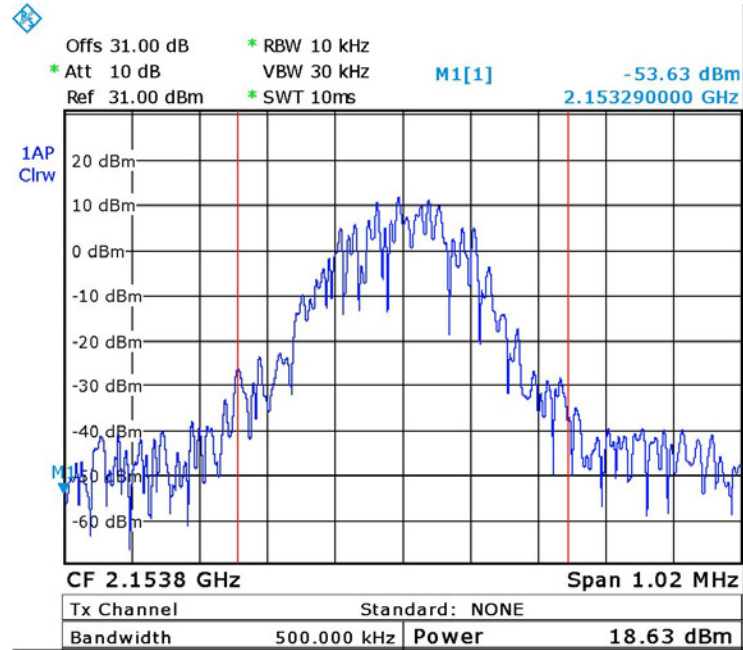

Date: 18.JUL.2016 09:23:25

Figure 13. — GSM (2153.8 MHz)

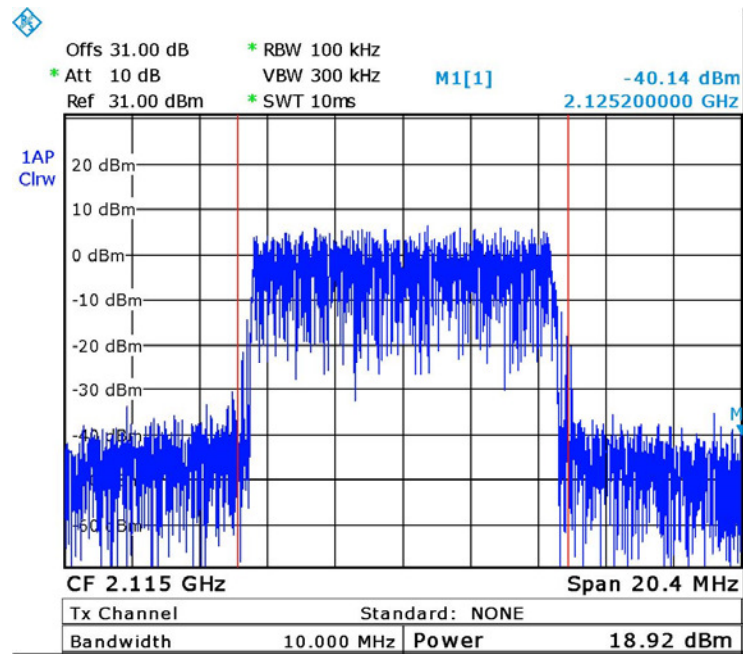

Date: 18.JUL.2016 09:13:04

Figure 14. — LTE 64QAM (2115.0 MHz)

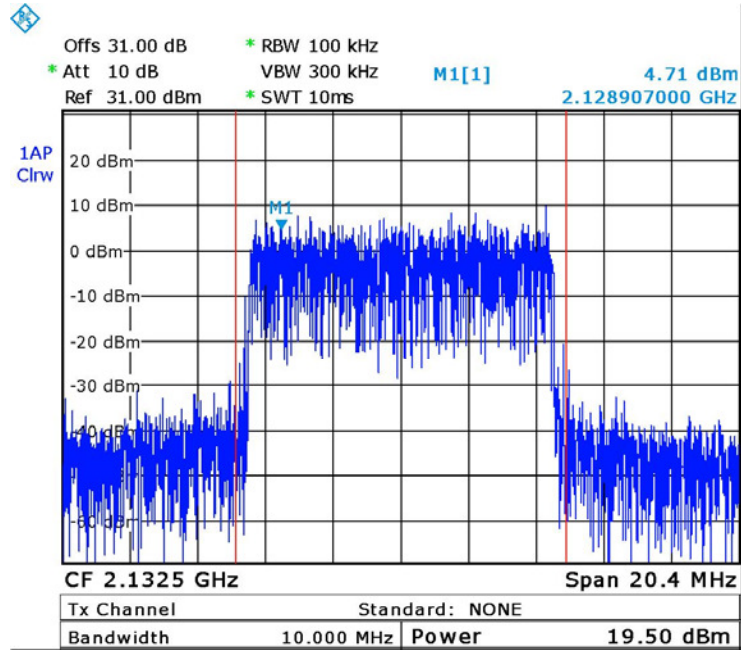

Date: 18.JUL.2016 09:12:19

Figure 15. — LTE 64QAM (2132.50MHz)

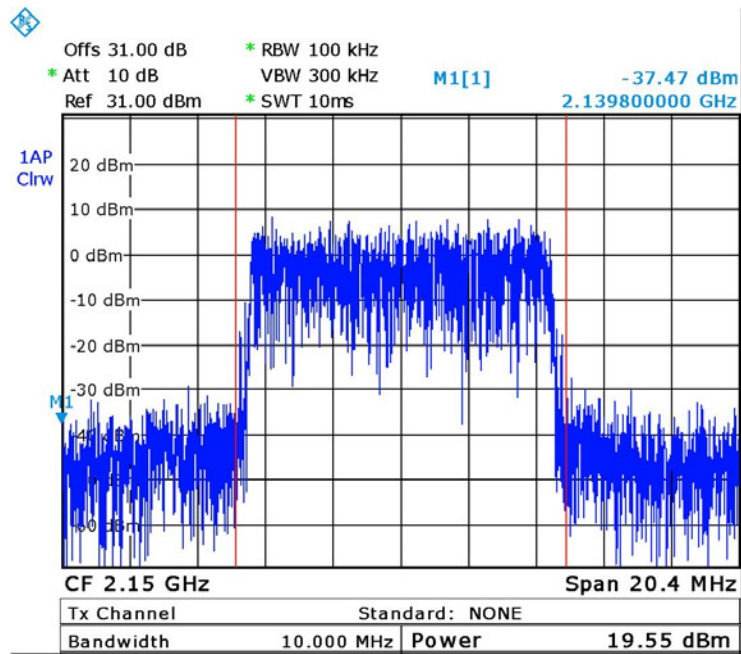

Date: 18.JUL.2016 09:13:38

Figure 16. — LTE 64QAM (2150.0MHz)

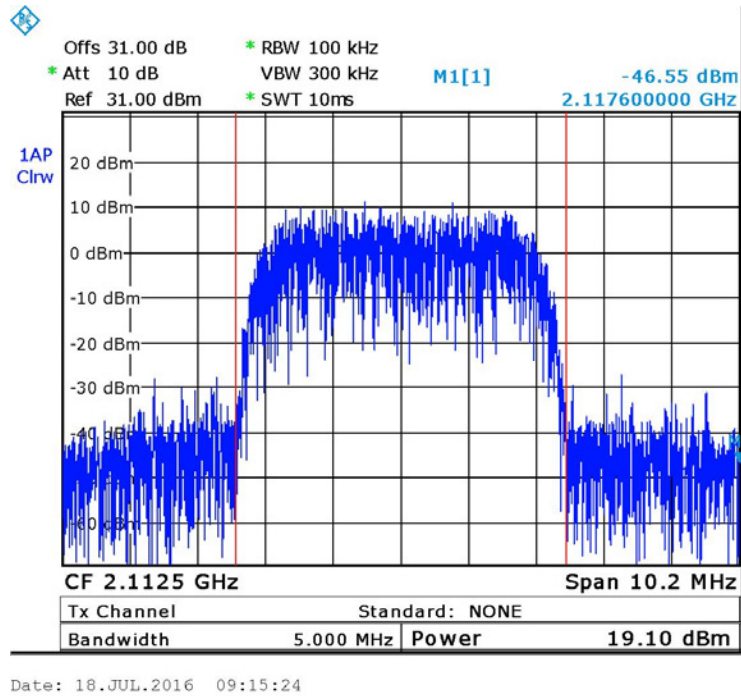

Figure 17. — W-CDMA (2112.5 MHz)

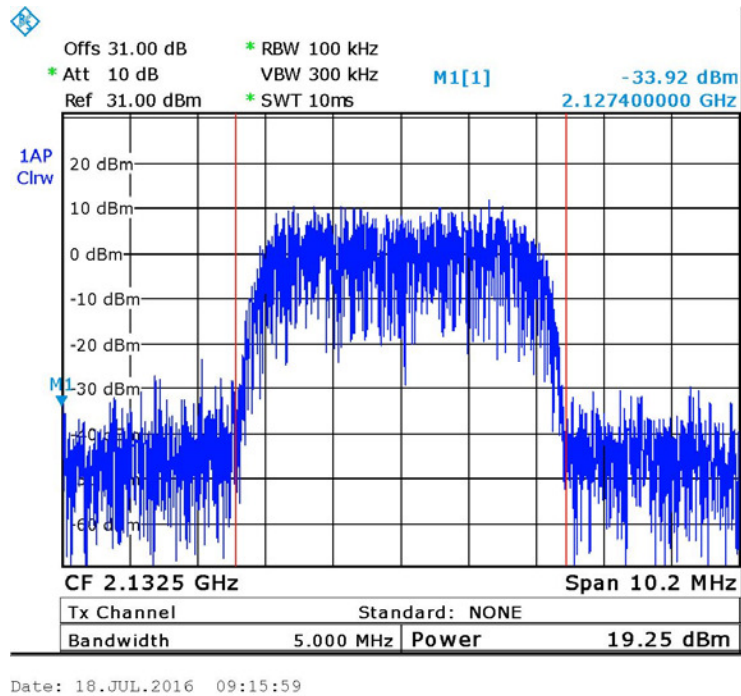
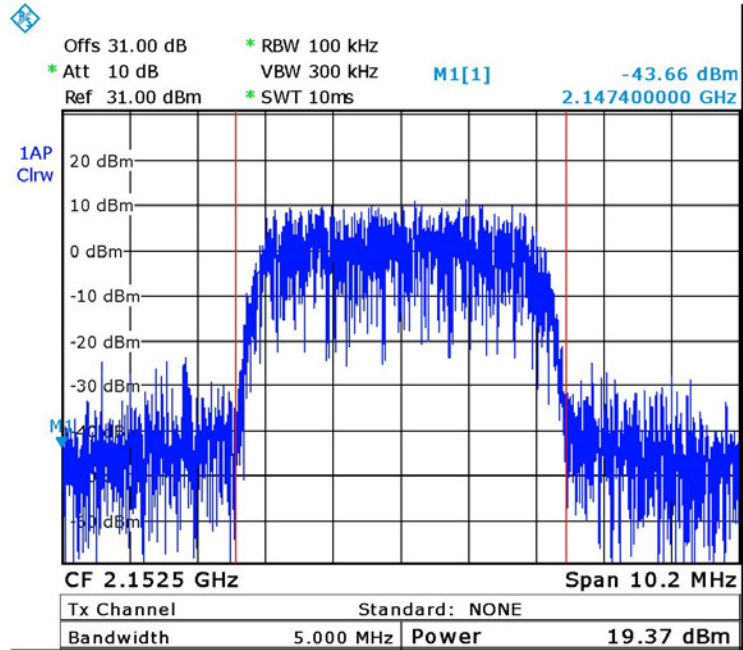

Figure 18. — W-CDMA (2132.5 MHz)



Date: 18.JUL.2016 09:16:33

Figure 19. — W-CDMA (2152.5MHz)



#### 4.5 Test Equipment Used; RF Power Output AWS

Instrument	Manufacturer	Model	Serial Number	Calibration	
				Last Calibration Date	Next Calibration Due
Spectrum Analyzer	R&S	FSL6	100194	February 29, 2016	March 1, 2017
Vector Signal Generator	Agilent	N5172B	MY51350584	July 1, 2016	July 1, 2017
30 dB Attenuator	MCL	BW-S30W5	533	July 5, 2016	July 5, 2017

Figure 20 Test Equipment Used

## 5. Occupied Bandwidth AWS

### 5.1 Test Specification

FCC Part 2, Section 1049

### 5.2 Test Procedure

(Temperature (22°C)/ Humidity (37%RH))

The E.U.T. antenna terminal was connected to the spectrum analyzer through an external attenuator and an appropriate coaxial cable (loss=31.0 dB).

The spectrum analyzer was set to proper resolution B.W.

OBW function (99%) was employed for these evaluation

Occupied bandwidth measured was repeated in the input terminal of the E.U.T.

### 5.3 Test Limit

N/A

### 5.4 Test Results

Modulation	Port	Operating Frequency	Reading
	(Input/ Output)	(MHz)	(MHz)
LTE 64QAM	Input	2115.0	9.0
	Output	2115.0	9.0
	Input	2132.5	8.9
	Output	2132.5	8.9
	Input	2150.0	8.9
	Output	2150.0	8.9
GSM	Input	2111.2	0.2
	Output	2111.2	0.2
	Input	2132.5	0.2
	Output	2132.5	0.2
	Input	2153.8	0.2
	Output	2153.8	0.2
W-CDMA	Input	2112.5	4.1
	Output	2112.5	4.1
	Input	2132.5	4.2
	Output	2132.5	4.2
	Input	2152.5	4.1
	Output	2152.5	4.1

Figure 21 Occupied Bandwidth AWS

JUDGEMENT: Passed

See additional information in *Figure 22* to *Figure 39*.

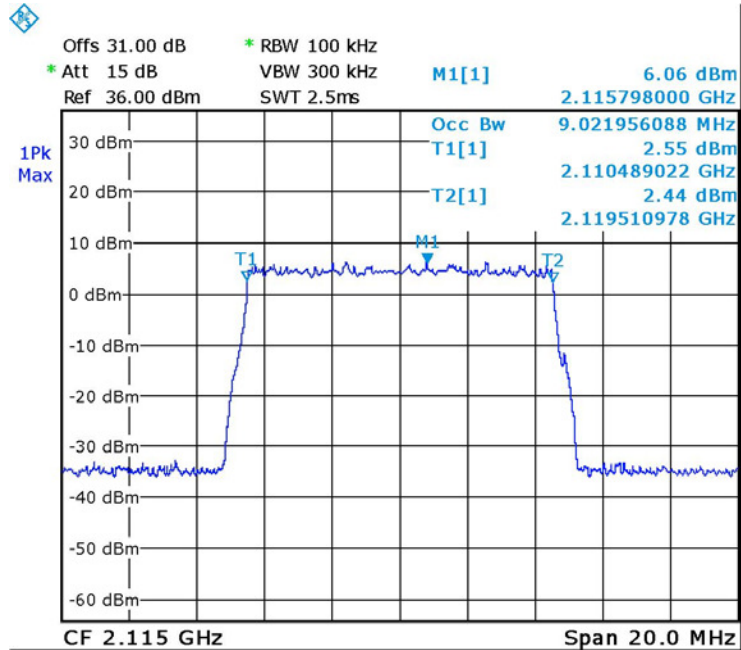

Date: 18.JUL.2016 09:51:47

Figure 22. — LTE 64QAM (2115.0 MHz) IN

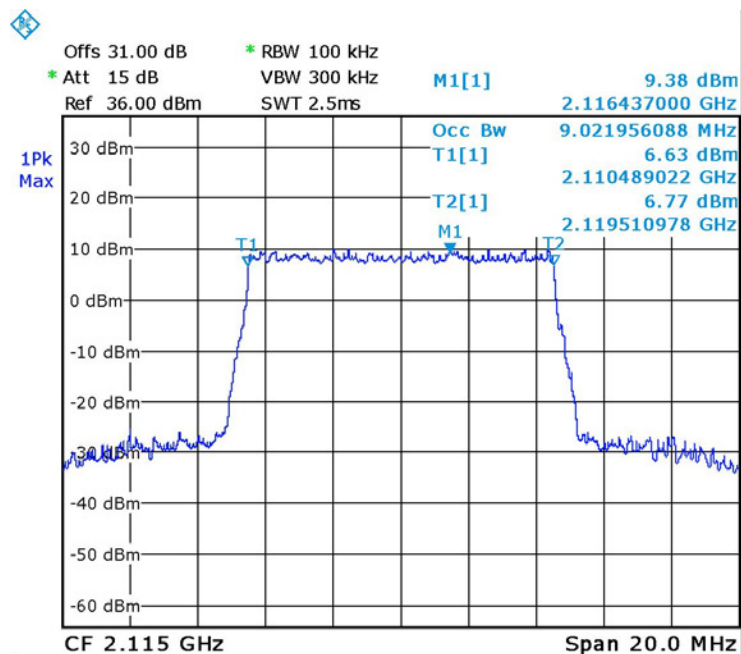

Date: 18.JUL.2016 09:48:44

Figure 23. — LTE 64QAM (2115.0 MHz) OUT

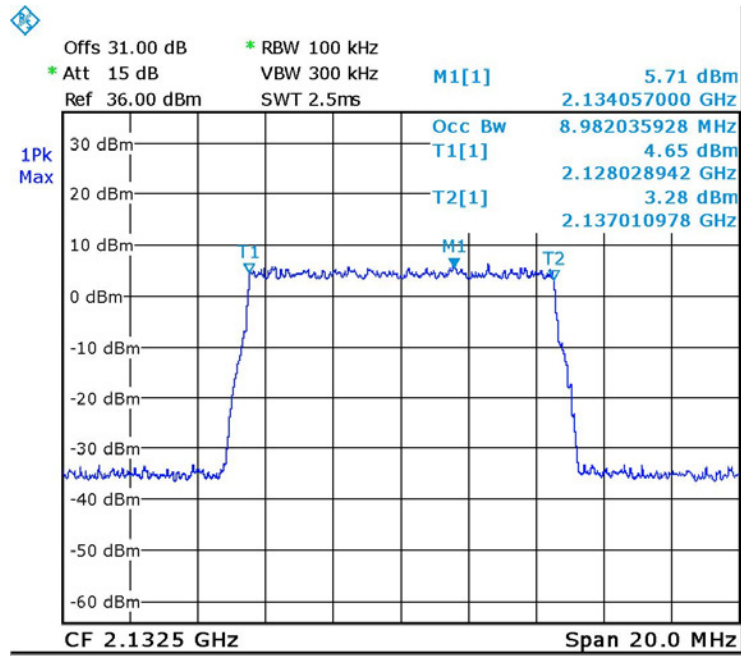

Date: 18.JUL.2016 09:52:47

Figure 24. — LTE 64QAM (2132.5MHz) IN

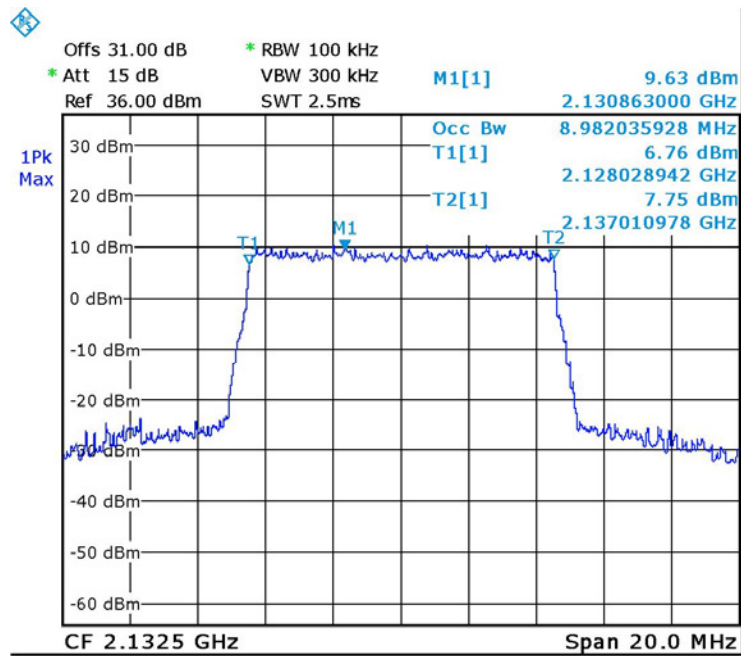

Date: 18.JUL.2016 09:47:55

Figure 25. — LTE 64QAM (2132.5MHz) OUT



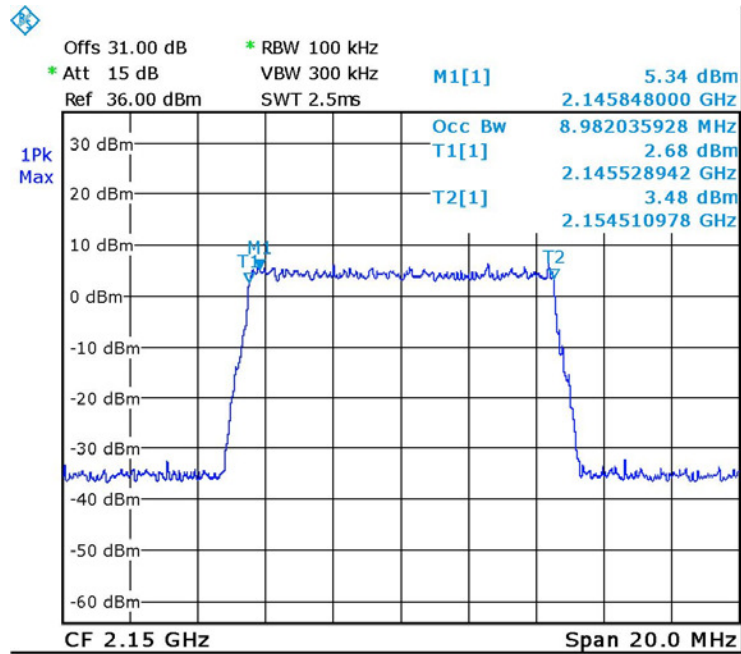

Date: 18.JUL.2016 09:56:15

Figure 26. — LTE 64QAM (2150.0 MHz) IN

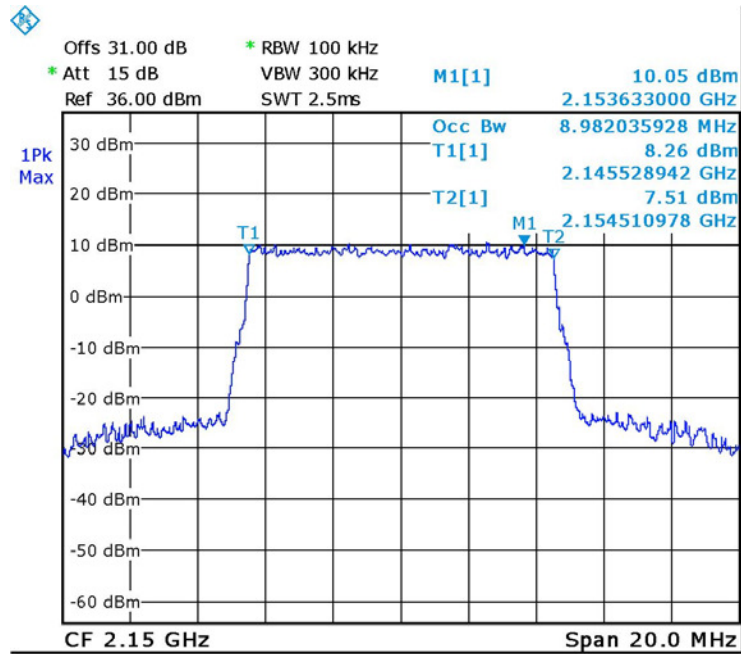

Date: 18.JUL.2016 09:47:16

Figure 27. — LTE 64QAM (2150.0 MHz) OUT

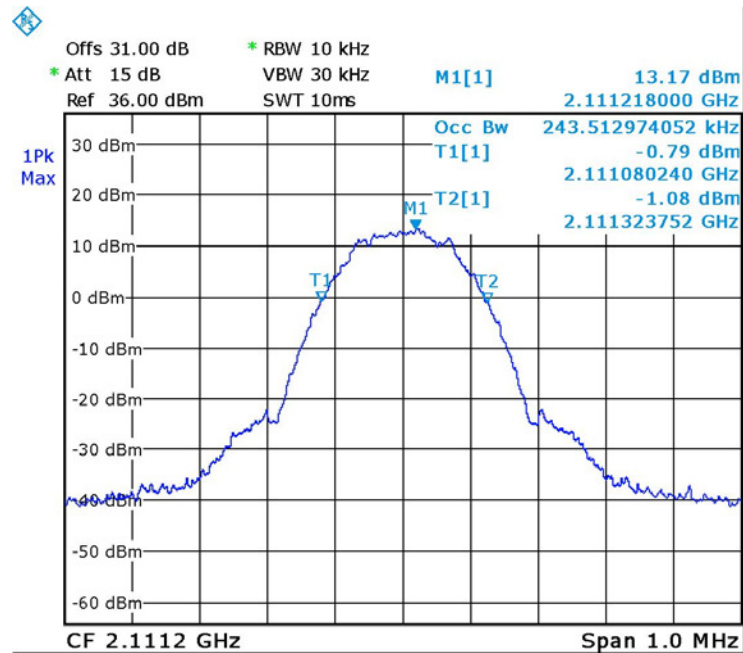

Date: 18.JUL.2016 10:04:31

Figure 28. — GSM (2111.2 MHz) IN

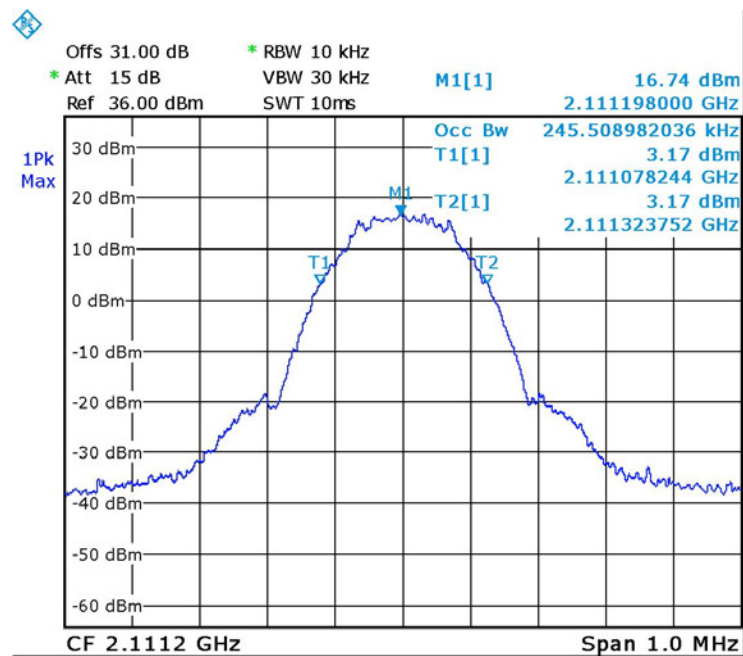

Date: 18.JUL.2016 09:37:20

Figure 29. — GSM (2111.2 MHz) OUT

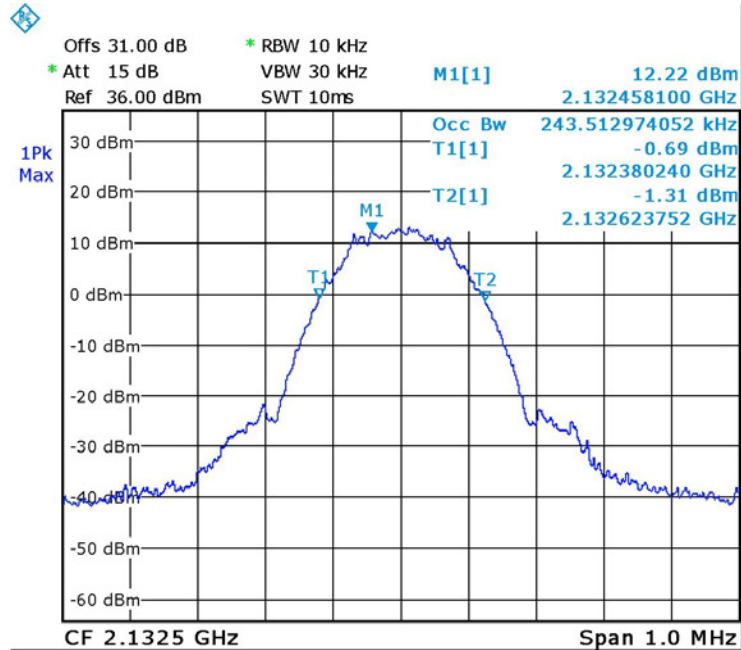

Date: 18.JUL.2016 10:02:58

Figure 30. — GSM (2132.5MHz) IN

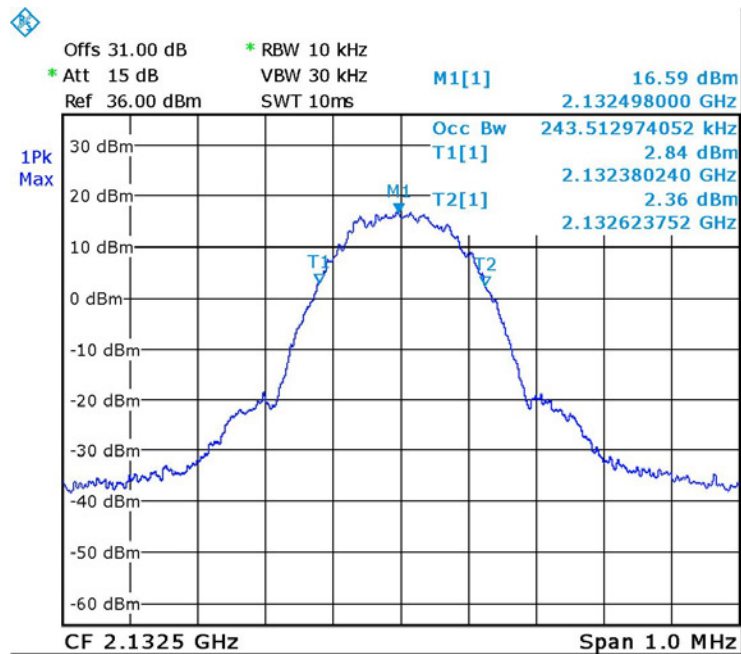

Date: 18.JUL.2016 09:36:21

Figure 31. — GSM (2132.5MHz) OUT

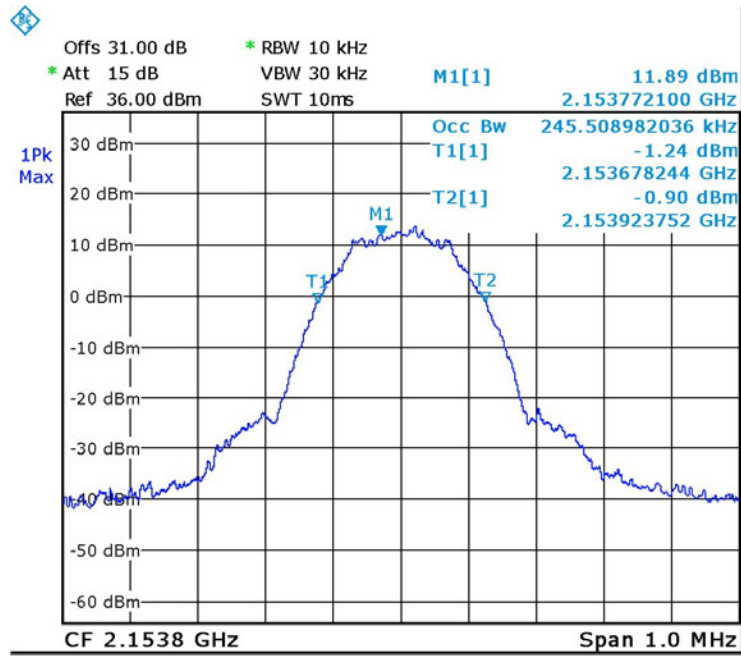

Date: 18.JUL.2016 10:02:23

Figure 32. — GSM (2153.8 MHz) IN

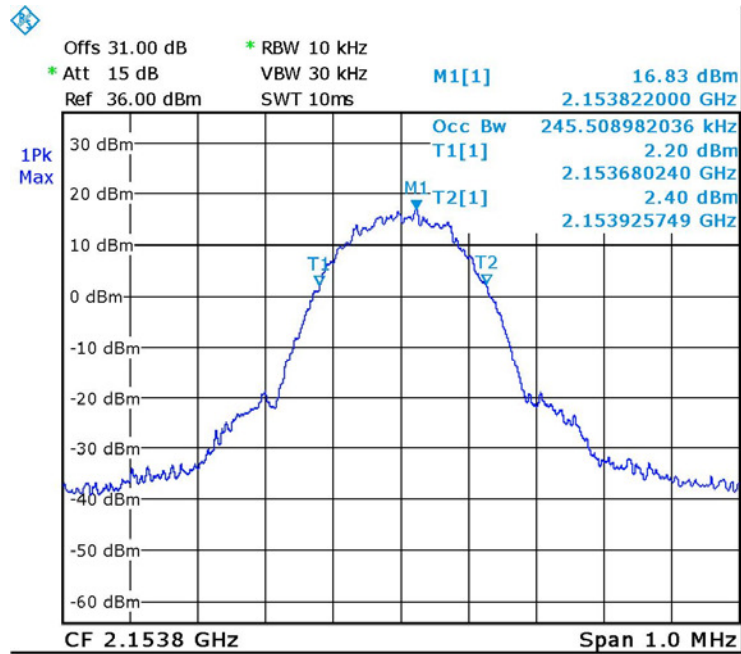

Date: 18.JUL.2016 09:35:09

Figure 33. — GSM (2153.8 MHz) OUT

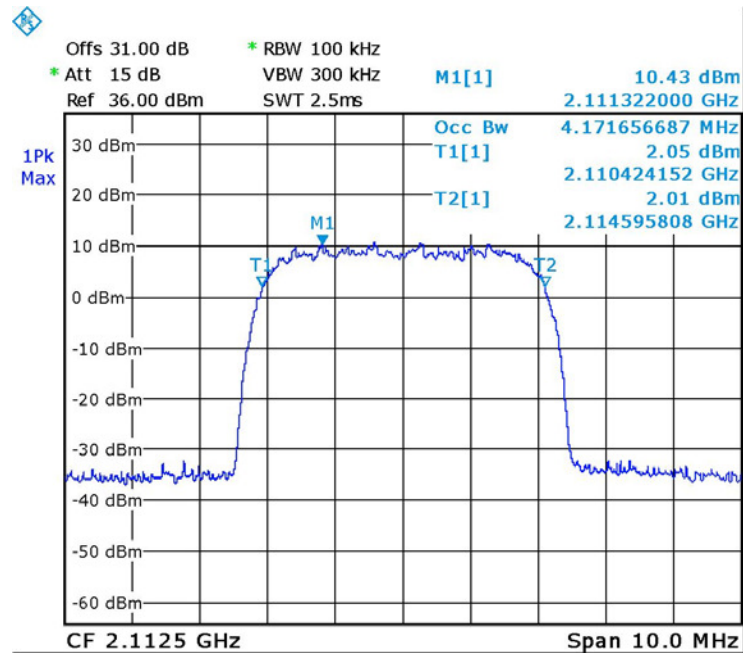

Date: 18.JUL.2016 09:57:54

Figure 34. — W-CDMA (2112.5 MHz) IN

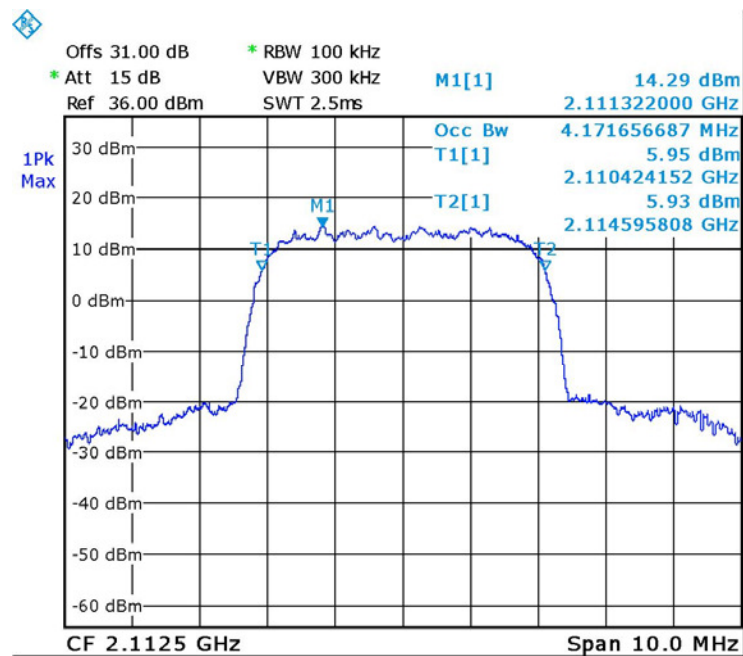

Date: 18.JUL.2016 09:40:06

Figure 35. — W-CDMA (2112.5 MHz) OUT

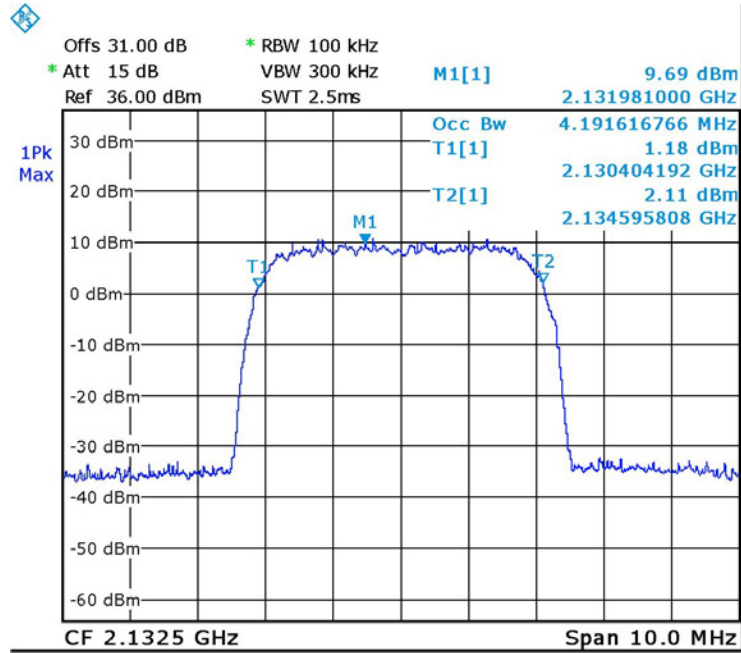

Date: 18.JUL.2016 09:58:29

Figure 36. — W-CDMA (2132.5MHz) IN

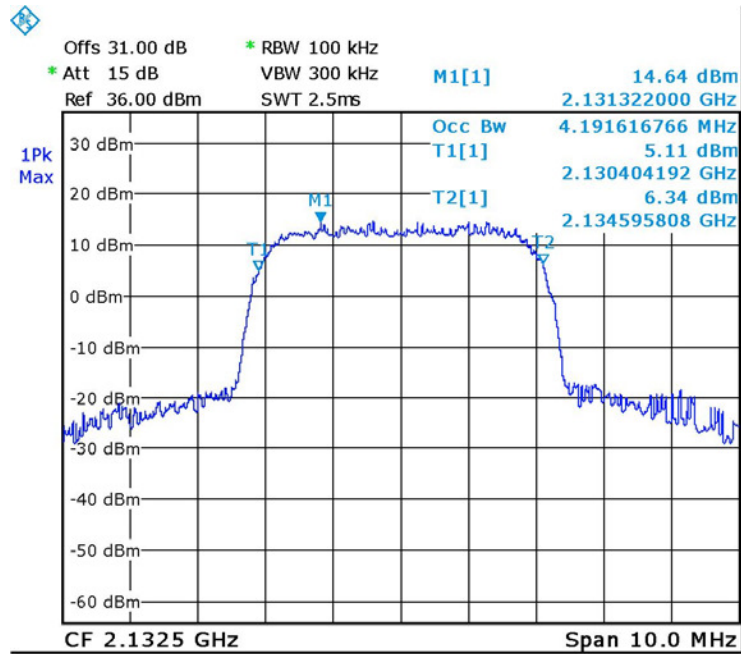

Date: 18.JUL.2016 09:40:39

Figure 37. — W-CDMA (2132.5MHz) OUT

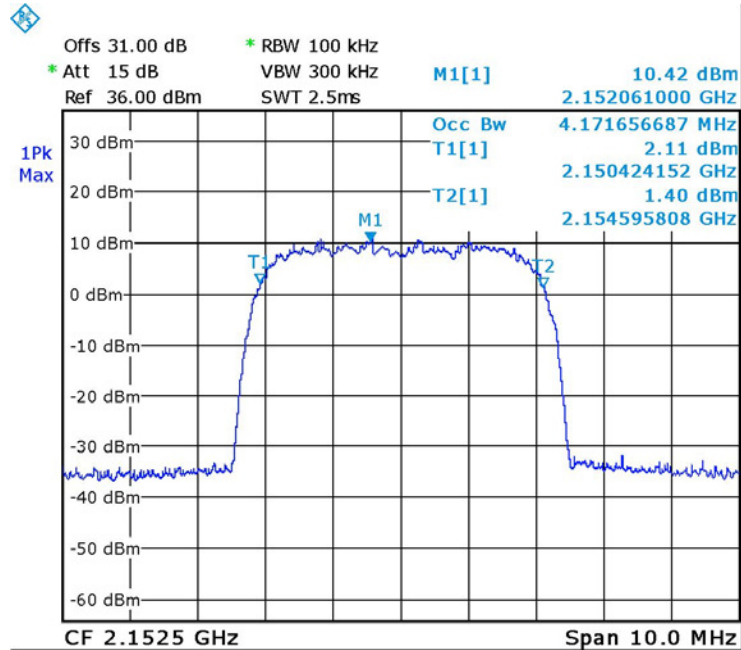

Date: 18.JUL.2016 09:59:30

Figure 38. — W-CDMA (2152.5 MHz) IN

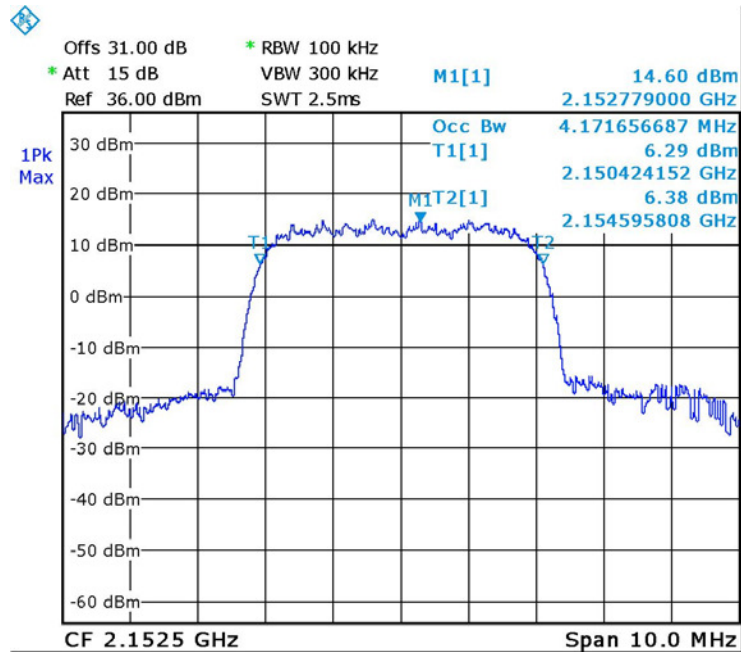

Date: 18.JUL.2016 09:41:36

Figure 39. — W-CDMA (2152.5 MHz) OUT



**5.5 Test Equipment Used; Occupied Bandwidth**

Instrument	Manufacturer	Model	Serial Number	Calibration	
				Last Calibration Date	Next Calibration Due
Spectrum Analyzer	R&S	FSL6	100194	February 29, 2016	March 1, 2017
Vector Signal Generator	Agilent	N5172B	MY51350584	July 1, 2016	July 1, 2017
30 dB Attenuator	MCL	BW-S30W5	533	July 5, 2016	July 5, 2017

**Figure 40 Test Equipment Used**





## 6. Spurious Emissions at Antenna Terminals AWS

### 6.1 Test Specification

FCC Part 27, Subpart C, Section: 27.53 (h)

### 6.2 Test Procedure

(Temperature (22°C)/ Humidity (35%RH))

The E.U.T. antenna terminal was connected to the spectrum analyzer through an external attenuator and an appropriate coaxial cable (max loss =34.0 dB). The spectrum analyzer was set to 1 kHz resolution BW for the frequency range 9.0-150.0 kHz, 10.0 kHz for the frequency range 150.0 kHz–1.0 MHz, 100.0 kHz for the frequency range 1.0 MHz – 30.0 MHz, and 1.0MHz for the frequency range 30.0 MHz - 22.0 GHz.

### 6.3 Test Limit

The power of any emission outside of the authorized operating frequency ranges (2110-2155MHz) must be attenuated below the transmitting power (P) by a factor of at least  $43 + \log (P)$  dB, yielding  $-13\text{dBm}$ .

### 6.4 Test Results

JUDGEMENT: Passed

See additional information in *Figure 41* to *Figure 49*.

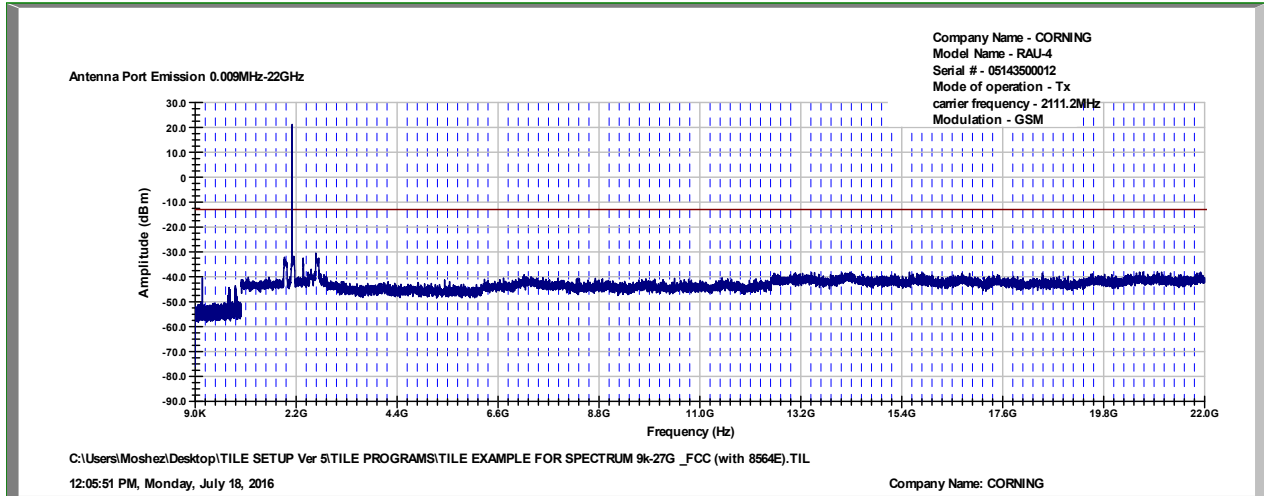

Figure 41 Spurious Emissions at Antenna Terminals GSM, 2111.2MHz

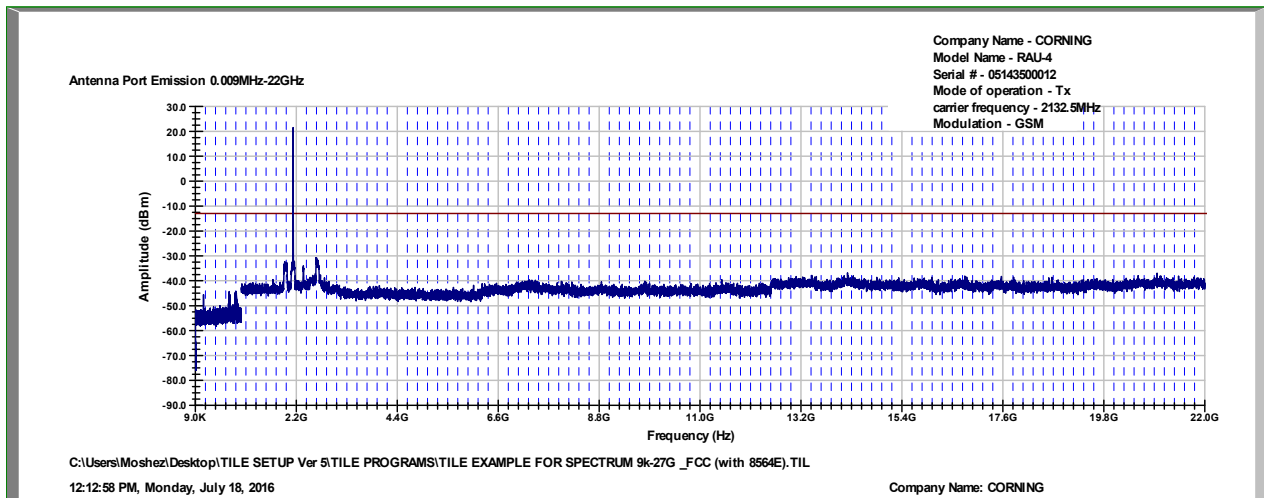

Figure 42 Spurious Emissions at Antenna Terminals GSM, 2132.5MHz

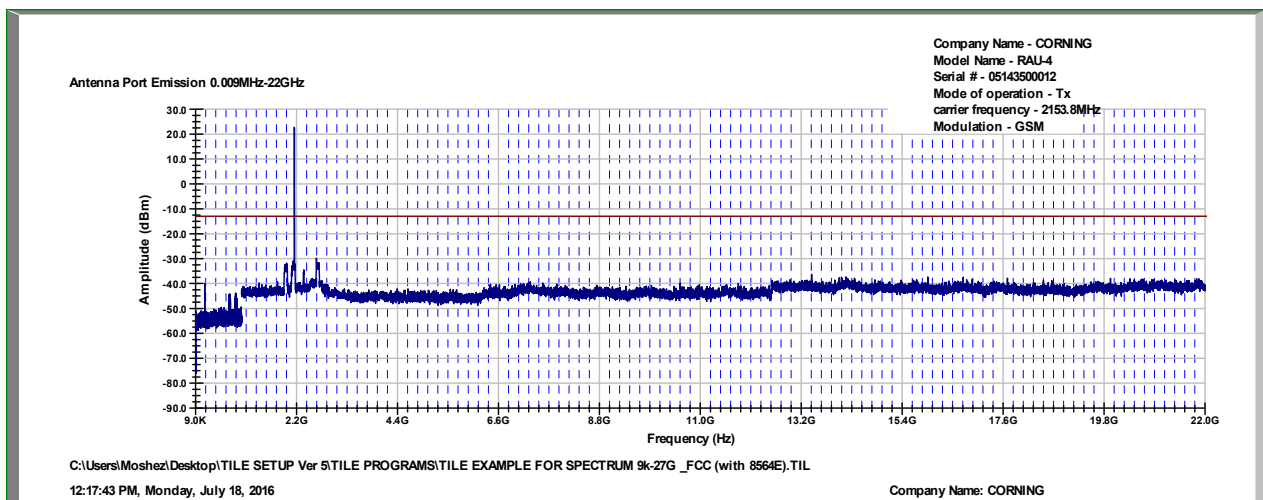

Figure 43 Spurious Emissions at Antenna Terminals GSM, 2153.8MHz

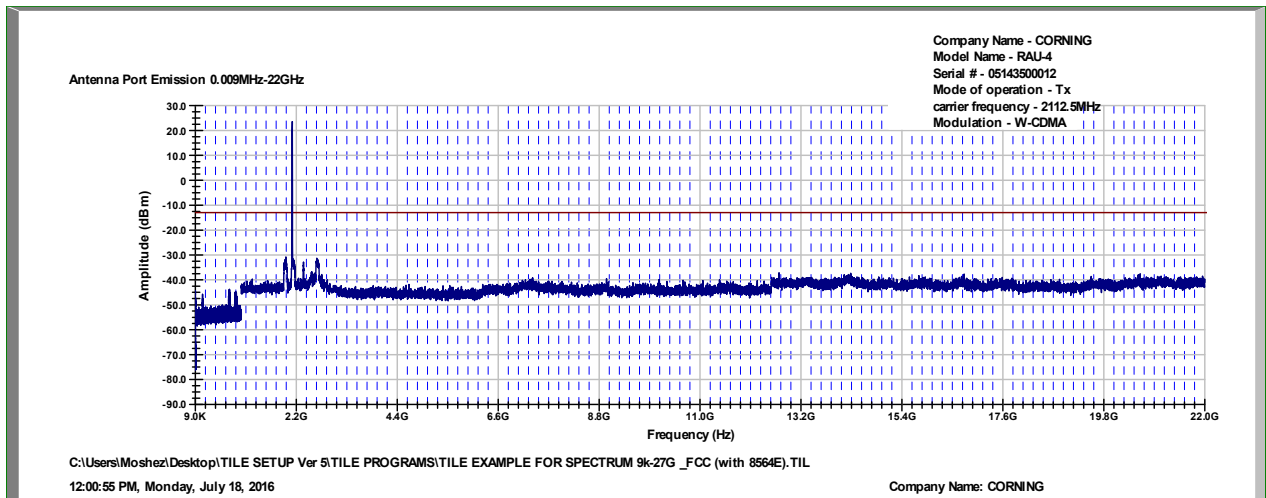

Figure 44 Spurious Emissions at Antenna Terminals WCDMA, 2112.5MHz

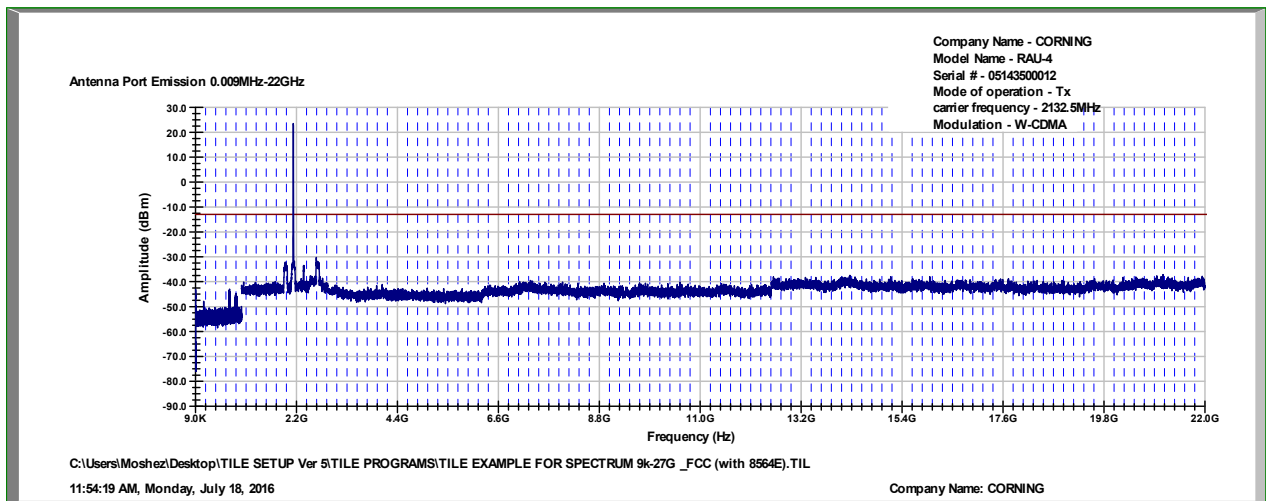

Figure 45 Spurious Emissions at Antenna Terminals WCDMA, 2132.5MHz

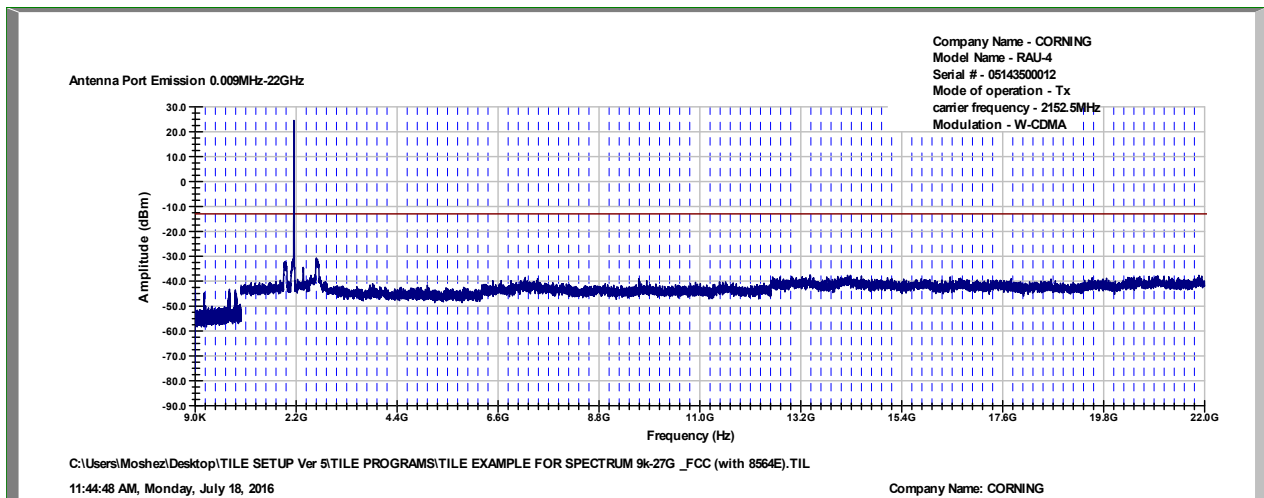

Figure 46 Spurious Emissions at Antenna Terminals WCDMA, 2152.5MHz

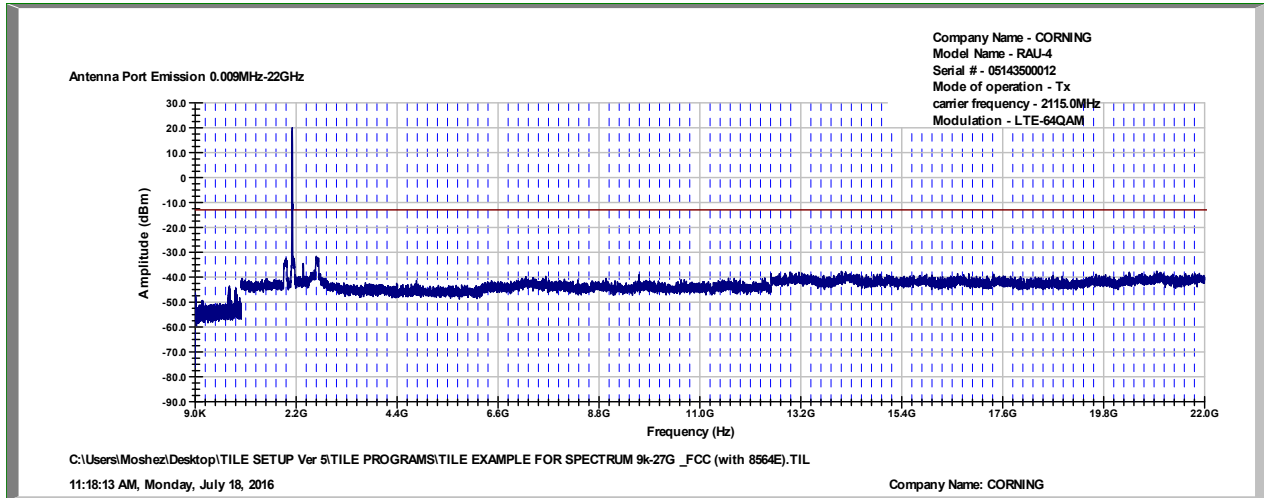

Figure 47 Spurious Emissions at Antenna Terminals LTE, 2115.0MHz

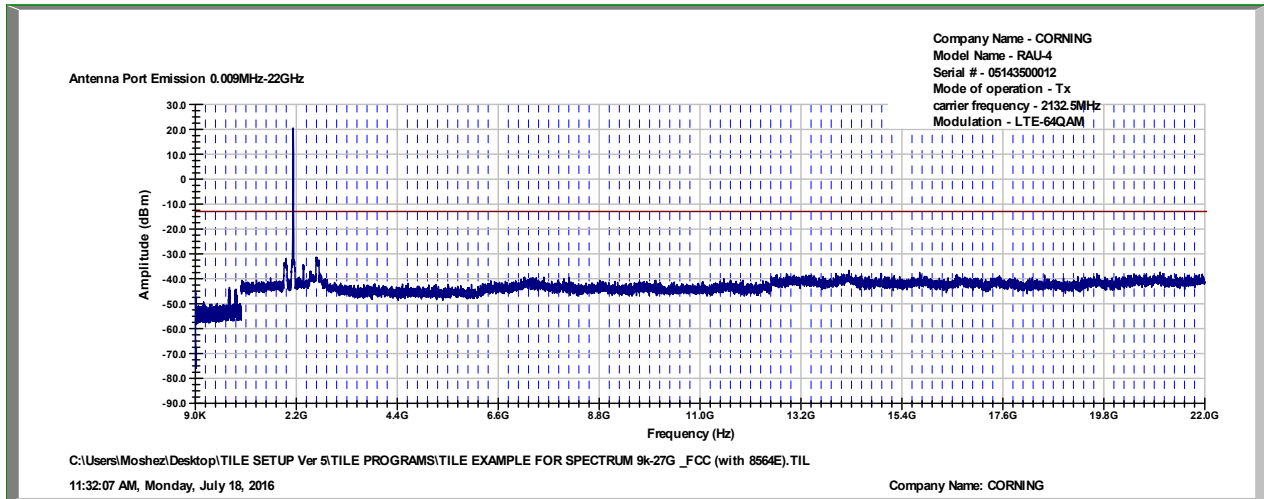

Figure 48 Spurious Emissions at Antenna Terminals LTE, 2132.5MHz

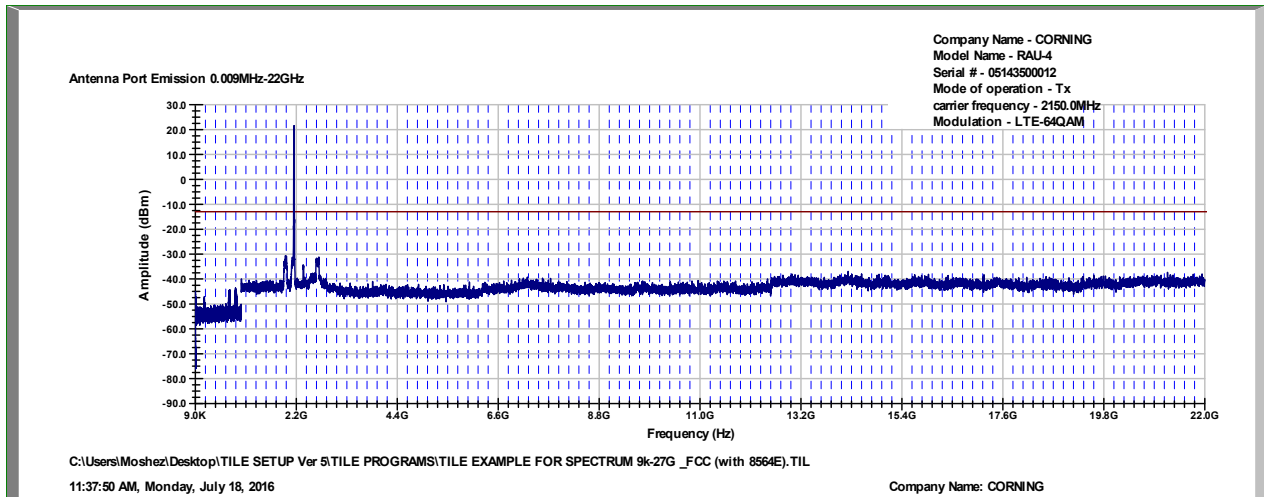

Figure 49 Spurious Emissions at Antenna Terminals LTE, 2150.0MHz



### 6.5 Test Equipment Used; Spurious Emissions at Antenna Terminals AWS

Instrument	Manufacturer	Model	Serial Number	Calibration	
				Last Calibration Date	Next Calibration Due
EXG Vector Signal Generator	Agilent	N5172B	MY51350584	July 1, 2016	July 1, 2017
Spectrum Analyzer	HP	8592L	3826A01204	March 13, 2016	March 13, 2017
30 dB Attenuator	MCL	BW-S30W5	533	July 5, 2016	July 5, 2017

Figure 50 Test Equipment Used

## 7. Band Edge Spectrum AWS

### 7.1 Test Specification

FCC Part 27, Subpart C, Section 27.53 (h)

### 7.2 Test Procedure

(Temperature (22°C)/ Humidity (35%RH))

The E.U.T. antenna terminal was connected to the spectrum analyzer through an external attenuator and an appropriate coaxial cable (loss = 31.0 dB).

RBW was setting to 100kHz.

### 7.3 Test Limit

The power of any emission outside of the authorized operating frequency ranges (2110-2155MHz) must be attenuated below the transmitting power (P) by a factor of at least  $43 + \log(P)$  dB, yielding -13dBm.

### 7.4 Test Results

Modulation	Operation Frequency	Band Edge Frequency	Reading	Limit	Margin
	(MHz)	(MHz)	(dBm)	(dBm)	(dB)
LTE 64QAM	2115.0	2110.0	-27.5	-13.0	-14.5
	2150.0	2155.0	-26.1	-13.0	-13.1
GSM	2111.2	2110.0	-32.9	-13.0	-19.9
	2153.8	2155.0	-31.0	-13.0	-18.0
W-CDMA	2112.5	2110.0	-19.7	-13.0	-6.7
	2152.5	2155.0	-15.8	-13.0	-2.8

**Figure 51 Band Edge Spectrum Results AWS**

JUDGEMENT: Passed by 2.8 dB

See additional information in *Figure 52 to Figure 57*.

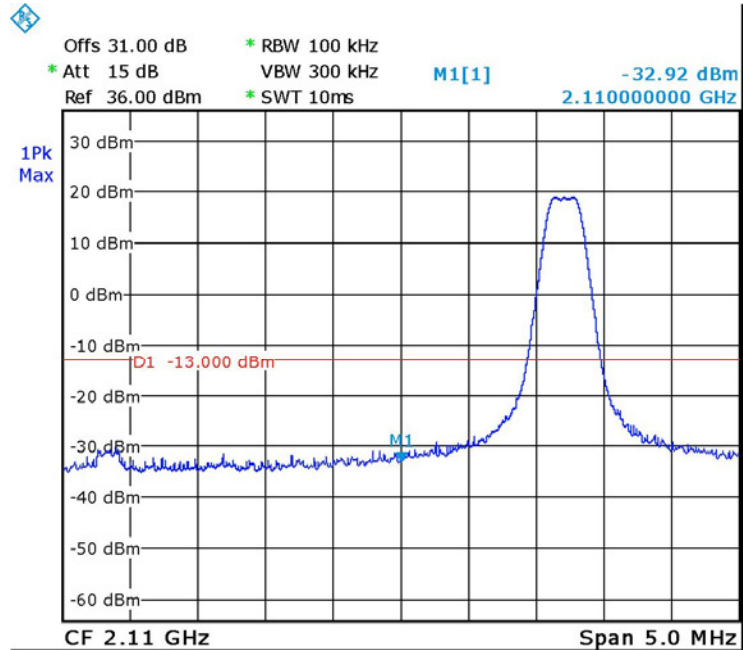

Date: 18.JUL.2016 10:26:33

Figure 52. — GSM 2111.2 MHz

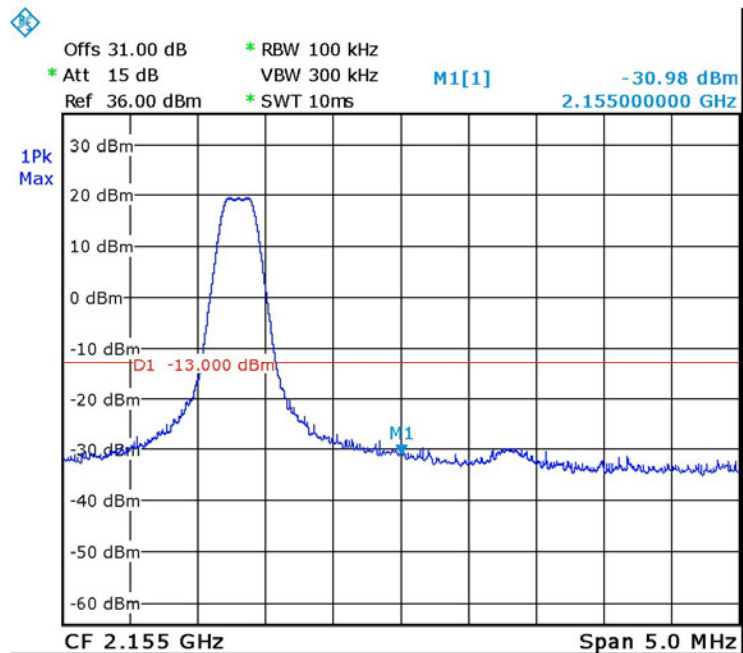

Date: 18.JUL.2016 10:27:37

Figure 53. — GSM 2153.8 MHz

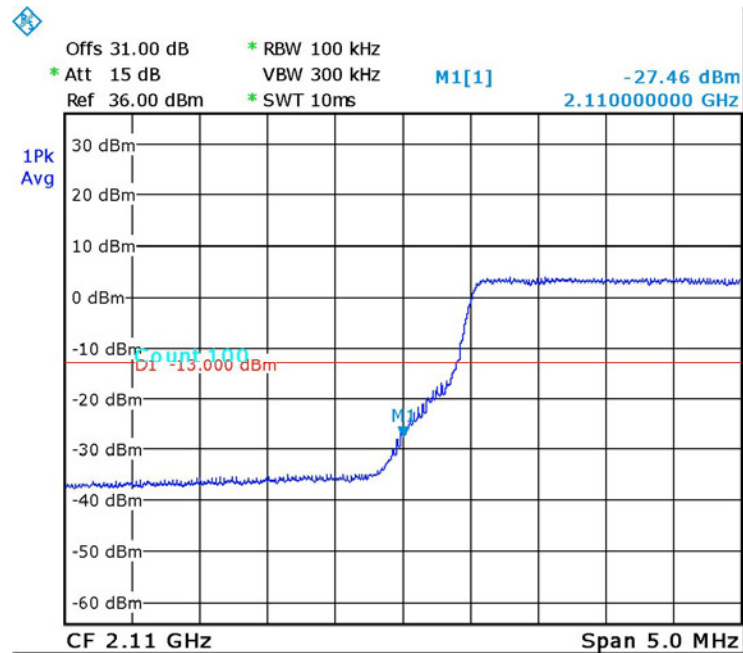

Date: 18.JUL.2016 10:34:38

Figure 54. — LTE 64QAM 2115.0 MHz

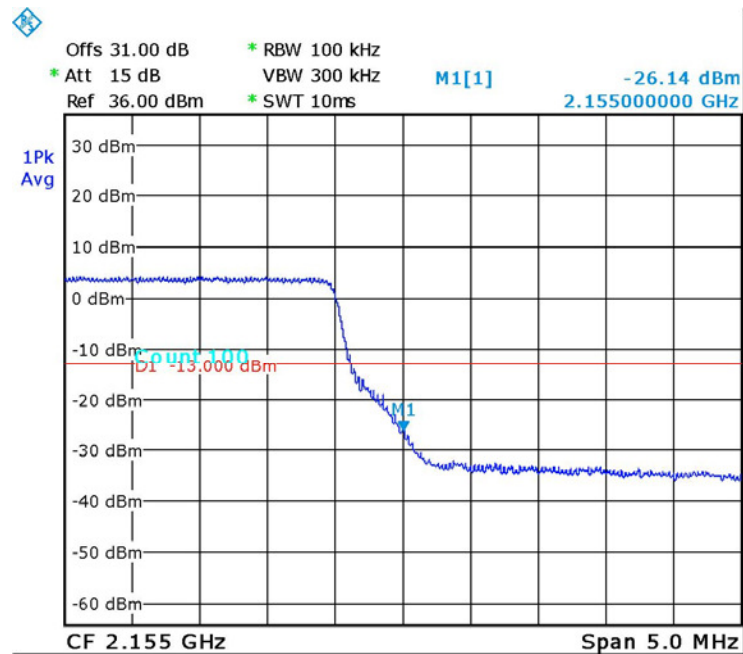

Date: 18.JUL.2016 10:33:57

Figure 55. — LTE 64QAM 2150.0 MHz



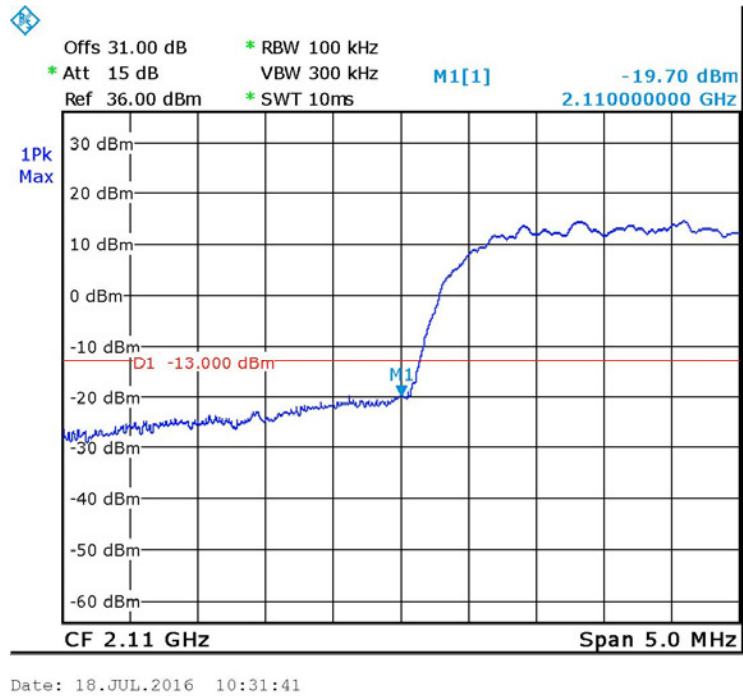

Figure 56. — W-CDMA 2112.5 MHz

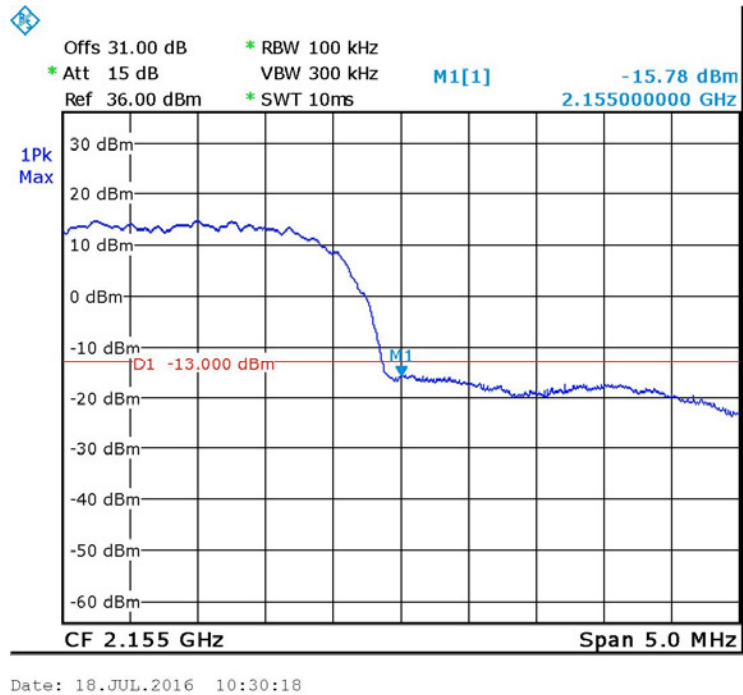

Figure 57. — W-CDMA 2152.5 MHz



**7.5 Test Equipment Used; Band Edge Spectrum AWS**

Instrument	Manufacturer	Model	Serial Number	Calibration	
				Last Calibration Date	Next Calibration Due
Spectrum Analyzer	R&S	FSL6	100194	February 29, 2016	March 1, 2017
Vector Signal Generator	Agilent	N5172B	MY51350584	July 1, 2016	July 1, 2017
30 dB Attenuator	MCL	BW-S30W5	533	July 5, 2016	July 5, 2017

**Figure 58 Test Equipment Used**



## 8. Spurious Radiated Emission AWS

### 8.1 Test Specification

FCC, Part 27, Subpart C, Section 27.53 (h)

### 8.2 Test Procedure

(Temperature (24°C)/ Humidity (50%RH))

The test method was based on ANSI/TIA-603-D: 2010, Section 2.2.12

Unwanted Emissions: Radiated Spurious.

The E.U.T. operation mode and test set-up are as described in Section 2 of this report.

#### **For measurements between 0.009MHz-30MHz:**

The E.U.T was tested inside the shielded room at a distance of 3 meters and the E.U.T was placed on a non-metallic table, 1.5 meters above the ground. The frequency range 0.009MHz-30MHz was scanned. The readings were maximized by the turntable azimuth between 0-360°, and the antenna polarization. The emissions were measured at a distance of 3 meters.

#### **For measurements between 30.0MHz-1.0GHz:**

A preliminary measurement to characterize the E.U.T was performed inside the shielded room at a distance of 3 meters, using peak detection mode and broadband antennas. The preliminary measurements produced a list of the highest emissions. The E.U.T was then transferred to the open site, and placed on a remote-controlled turntable. The E.U.T was placed on a non-metallic table, 0.8 meters above the ground. The frequency range 30.0MHz -1.0GHz was scanned and the list of the highest emissions was verified and updated accordingly.

The readings were maximized by adjusting the antenna height between 1-4 meters, the turntable azimuth between 0-360°, and the antenna polarization. The emissions were measured at a distance of 3 meters.

#### **For measurements between 1.0GHz-22.0GHz:**

The E.U.T was tested inside the shielded room at a distance of 3 meters and the E.U.T was placed on a non-metallic table, 1.5 meters above the ground. The frequency range 1.0GHz -22.0GHz was scanned. The readings were maximized by the turntable azimuth between 0-360°, and the antenna polarization. The emissions were measured at a distance of 3 meters.

The E.U.T. was replaced by a substitution antenna (dipole 30MHz-1GHz, Horn Antenna above 1GHz) driven by a signal generator. The height was readjusted for maximum reading. The signal generator level was adjusted to obtain the same reading on the EMI receiver as in step (a).

The signals observed in step (a) were converted to radiated power using:

$$P_d(\text{dBm}) = P_g(\text{dBm}) - \text{Cable Loss (dB)} + \text{Substitution Antenna Gain (dBd)}$$

$P_d$  = Dipole equivalent power (result).

$P_g$  = Signal generator output level.



A Peak detector was used for this test.

The test was performed in 3 operation frequencies: low, mid and high.

Testing was performed when the RF port was connected to 50 Ω termination.

The table below describe only results with the highest radiation.

### 8.3 Test Limit

The power of any emission outside of the authorized operating frequency ranges (2110-2180 MHz) must be attenuated below the transmitting power (P) by a factor of at least  $43 + 10 \log (P)$  dB, yielding -13dBm

### 8.4 Test Results

Carrier Channel	Freq.	Antenna Pol.	Maximum Peak Level	Signal Generator RF Output	Cable Loss	Antenna Gain	Effective Radiated Power Level	Limit	Margin
(MHz)	(MHz)	(V/H)	(dBμV/m)	(dBm)	(dB)	(dBd)	(dBm)	(dBm)	(dB)
2111.2	4222.4	V	57.0	-48.0	0.5	9.5	-39.0	-13.0	-26.0
	4222.4	H	56.8	-48.0	0.5	9.5	-39.0	-13.0	-26.0
2132.5	4265.0	V	57.0	-48.0	0.5	9.5	-39.0	-13.0	-26.0
	4265.0	H	57.1	-48.0	0.5	9.5	-39.0	-13.0	-26.0
2153.8	4307.6	V	57.1	-48.0	0.5	9.5	-39.0	-13.0	-26.0
	4307.6	H	57.3	-47.5	0.5	9.5	-38.5	-13.0	-25.5

Figure 59 Spurious Radiated Emission AWS

The E.U.T met the requirements of the FCC, Part 27, Subpart C, Section 27.53 (h) specifications.

JUDGEMENT: Passed by 25.5dB



**8.5 Test Instrumentation Used, Radiated Measurements AWS**

Instrument	Manufacturer	Model	Serial Number	Calibration	
				Last Calibration Date	Next Calibration Due
EMI Receiver	HP	85422E	3906A00276	March 3, 2016	March 3, 2017
RF Filter Section	HP	85420E	3705A00248	March 3, 2016	March 3, 2017
EMI Receiver	R&S	ESCI7	100724	February 29, 2016	March 1, 2017
Spectrum Analyzer	HP	8593EM	3536A00120ADI	March 10, 2016	March 10, 2017
Active Loop Antenna	EMCO	6502	9506-2950	November 5, 2015	November 30, 2016
Antenna Biconical	EMCO	3110B	9912-3337	March 24, 2016	March 24, 2018
Antenna Log Periodic	EMCO	3146	9505-4081	April 23, 2016	April 23, 2017
Horn Antenna 1G-18G	ETS	3115	29845	May 19, 2015	May 19, 2018
Horn Antenna 18G-26G	ARA	SWH-28	1007	March 30, 2014	September 30, 2016
Low Noise Amplifier	Narda	LNA-DBS-0411N313	013	March 1, 2015	September 30, 2016
Low Noise Amplifier	Sophia Wireless	LNA 28-B	232	March 1, 2015	September 30, 2016
MXG Vector Signal Generator	Agilent	N5182A	MY49060440	July 1, 2016	July 1, 2017
Semi Anechoic Civil Chamber	ETS	S81	SL 11643	N/A	N/A
Antenna Mast	ETS	2070-2	-	N/A	N/A
Turntable	ETS	2087	-	N/A	N/A
Mast & Table Controller	ETS/EMCO	2090	9608-1456	N/A	N/A

**Figure 60 Test Equipment Used**



## 9. Intermodulation Conducted

### 9.1 Test Procedure

(Temperature (22°C)/ Humidity (37%RH))

The E.U.T. antenna terminal was connected to the spectrum analyzer through an external attenuator and an appropriate coaxial cable (max loss = 34.0dB). The spectrum analyzer was set to 1 kHz resolution BW for the frequency range 9.0-150.0 kHz, 10 kHz for the frequency range 150 kHz-1.0 MHz, 100 kHz for the frequency range 1.0 MHz – 30 MHz, and 1MHz for the frequency range 30 MHz - 24GHz.

6 input signals were sent simultaneously to the E.U.T. as follows:

LTE band: 742.0 MHz, 0 dBm

CELL band: 878.0 MHz, 0 dBm

PCS band: 1962.5 MHz, 0 dBm

AWS band: 2132.5 MHz, 0 dBm

WCS band: 2355.0MHz, 0 dBm

TDD 2.5G band: 2593.0 MHz, 0 dBm

The frequency range of 9 kHz – 24.0 GHz was scanned for unwanted signals.

### 9.2 Test Limit

The power of any emission outside of the authorized operating frequency ranges must be attenuated below the transmitting power (P) by a factor of at least  $43 + 10 \log (P)$  dB, yielding -13dBm.

### 9.3 Test Results

JUDGEMENT: Passed

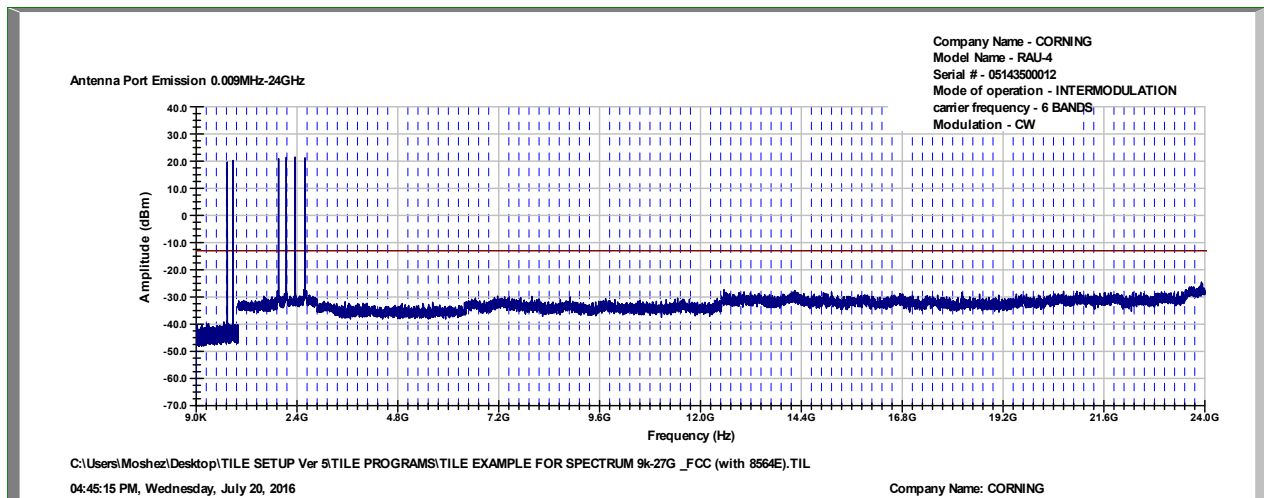

Figure 61 Intermodulation Conducted



**9.4 Test Equipment Used; Intermodulation Conducted**

Instrument	Manufacturer	Model	Serial Number	Calibration	
				Last Calibration Date	Next Calibration Due
Spectrum Analyzer	HP	8564E	3442A00275	March 10, 2016	March 10, 2017
EXG Vector Signal Generator	Agilent	N5172B	TE4384	July 1, 2016	July 1, 2017
EXG Vector Signal Generator	Agilent	N5172B	MY513500584	July 1, 2016	July 1, 2017
MXG Vector Signal Generator	Agilent	N5182A	MY48180244	July 1, 2016	July 1, 2017
MXG Vector Signal Generator	Agilent	N5182A	MY49060440	July 1, 2016	July 1, 2017
Signal Generator	HP	E4432B	GB40050998	July 1, 2016	July 1, 2017
ESG Vector Signal Generator	Agilent	E4438C	MY45094064	July 1, 2016	July 1, 2017
30 dB Attenuator	MCL	BW-S30W5	533	July 5, 2016	July 5, 2017
6 dB Attenuator	Weinschel Associates	WA 40-6-34	568	July 6, 2016	July 6, 2017

**Figure 62 Test Equipment Used**



## 10. Intermodulation Radiated

### 10.1 Test Procedure

(Temperature (24°C)/ Humidity (50%RH))

The test method was based on ANSI/TIA-603- D: 2010, Section 2.2.12 Unwanted Emissions: Radiated Spurious.

#### **For measurements between 0.009MHz-30MHz:**

The E.U.T was tested inside the shielded room at a distance of 3 meters and the E.U.T was placed on a non-metallic table, 1.5 meters above the ground. The frequency range 0.009MHz-30MHz was scanned. The readings were maximized by the turntable azimuth between 0-360°, and the antenna polarization.

The emissions were measured at a distance of 3 meters.

#### **For measurements between 30.0MHz-1.0GHz:**

A preliminary measurement to characterize the E.U.T was performed inside the shielded room at a distance of 3 meters, using peak detection mode and broadband antennas. The preliminary measurements produced a list of the highest emissions. The E.U.T was then transferred to the open site, and placed on a remote-controlled turntable. The E.U.T was placed on a non-metallic table, 0.8 meters above the ground. The frequency range 30.0MHz -1.0GHz was scanned and the list of the highest emissions was verified and updated accordingly.

The readings were maximized by adjusting the antenna height between 1-4 meters, the turntable azimuth between 0-360°, and the antenna polarization.

The emissions were measured at a distance of 3 meters.

#### **For measurements between 1.0GHz-24.0GHz:**

The E.U.T was tested inside the shielded room at a distance of 3 meters and the E.U.T was placed on a non-metallic table, 1.5 meters above the ground. The frequency range 1.0GHz -24.0GHz was scanned. The readings were maximized by the turntable azimuth between 0-360°, and the antenna polarization.

The emissions were measured at a distance of 3 meters.

The E.U.T. was replaced by a substitution antenna (dipole 30MHz-1GHz, Horn Antenna above 1GHz) driven by a signal generator.

The height was readjusted for maximum reading. The signal generator level was adjusted to obtain the same reading on the EMI receiver as in step (a).

The signals observed in step (a) were converted to radiated power using:

$$P_d(\text{dBm}) = P_g(\text{dBm}) - \text{Cable Loss (dB)} + \text{Substitution Antenna Gain (dBd)}$$

$P_d$  = Dipole equivalent power (result).

$P_g$  = Signal generator output level.





6 input signals were sent simultaneously to the E.U.T. as follows:

LTE band: 742.0 MHz, 0 dBm

CELL band: 878.0 MHz, 0 dBm

PCS band: 1962.5 MHz, 0 dBm

AWS band: 2132.5 MHz, 0 dBm

WCS band: 2355.0MHz, 0 dBm

TDD 2.5G band: 2593.0MHz, 0 dBm

A Peak detector was used for this test.

The test was performed in 3 operation frequencies: low, mid and high.

Testing was performed when the RF port was connected to 50  $\Omega$  termination.

The table below describe only results with the highest radiation.

### **10.2 Test Limit**

The power of any emission outside of the authorized operating frequency ranges (728-758; 869-894; 1930-1990; 2110-2155 MHz;2350-2360MHz) must be attenuated below the transmitting power (P) by a factor of at least  $43 + 10 \log (P)$  dB, yielding  $-13$ dBm.

### **10.3 Test Results**

JUDGEMENT:                      Passed

For additional information see Figure 63.



Freq.	Antenna Pol.	Maximum Peak Level	Signal Generator RF Output	Cable Loss	Antenna Gain	Effective Radiated Power Level	Limit	Margin
(MHz)	(V/H)	(dB $\mu$ V/m)	(dBm)	(dB)	(dBd)	(dBm)	(dBm)	(dB)
1792.5	V	53.2	-49.6	0.5	7.0	-43.1	-13.0	-30.1
1792.5	H	53.0	-49.8	0.5	7.0	-43.3	-13.0	-30.3
2219.0	V	54.1	-48.6	0.5	7.0	-42.1	-13.0	-29.1
2219.0	H	54.0	-48.8	0.5	7.0	-42.3	-13.0	-29.3
3223.5	V	54.2	-50.6	0.5	10.0	-41.1	-13.0	-28.1
3223.5	H	54.4	-50.0	0.5	10.0	-40.5	-13.0	-27.5
3854.0	V	54.3	-50.5	0.5	9.5	-41.5	-13.0	-28.5
3854.0	H	54.3	-50.5	0.5	9.5	-41.5	-13.0	-28.5
3978.5	V	54.3	-50.7	0.5	9.5	-41.7	-13.0	-28.7
3978.5	H	54.5	-50.5	0.5	9.5	-41.5	-13.0	-28.5
4104.0	V	54.3	-50.7	0.5	9.5	-41.7	-13.0	-28.7
4104.0	H	54.7	-50.5	0.5	9.5	-41.5	-13.0	-28.5
4201.0	V	54.5	-50.7	0.5	9.5	-41.7	-13.0	-28.7
4201.0	H	54.5	-50.5	0.5	9.5	-41.5	-13.0	-28.5
4308.0	V	54.5	-50.4	0.5	9.5	-41.4	-13.0	-28.4
4308.0	H	54.5	-50.5	0.5	9.5	-41.5	-13.0	-28.5
4439.0	V	54.5	-50.4	0.5	9.5	-41.4	-13.0	-28.4
4439.0	H	54.5	-50.5	0.5	9.5	-41.5	-13.0	-28.5
5445.0	V	54.9	-50.0	0.5	10.5	-40.0	-13.0	-27
5445.0	H	54.8	-49.5	0.5	10.8	-39.2	-13.0	-26.2

Figure 63 Intermodulation Radiated Results



**10.4 Test Instrumentation Used; Radiated Measurements Intermodulation**

Instrument	Manufacturer	Model	Serial Number	Calibration	
				Last Calibration Date	Next Calibration Due
EMI Receiver	HP	85422E	3906A00276	March 3, 2016	March 3, 2017
RF Filter Section	HP	85420E	3705A00248	March 3, 2016	March 3, 2017
EMI Receiver	R&S	ESCI7	100724	February 29, 2016	March 1, 2017
Spectrum Analyzer	HP	8593EM	3536A00120ADI	March 10, 2016	March 10, 2017
Active Loop Antenna	EMCO	6502	9506-2950	November 5, 2015	November 30, 2016
Antenna Biconical	EMCO	3110B	9912-3337	March 24, 2016	March 24, 2018
Antenna Log Periodic	EMCO	3146	9505-4081	April 23, 2016	April 23, 2017
Horn Antenna 1G-18G	ETS	3115	29845	May 19, 2015	May 19, 2018
Horn Antenna 18G-26G	ARA	SWH-28	1007	March 30, 2014	September 30, 2016
Low Noise Amplifier	Narda	LNA-DBS-0411N313	013	March 1, 2015	September 30, 2016
Low Noise Amplifier	Sophia Wireless	LNA 28-B	232	March 1, 2015	September 30, 2016
Signal Generator	Marconi	2022D	119196015	March 1, 2016	March 1, 2017
Signal Generator	HP	8648C	3623A04126	February 29, 2016	March 1, 2017
Signal Generator	HP	ESG-4000A/E442 2A	US36220118	February 29, 2016	March 1, 2017
MXG Vector Signal Generator	Agilent	N5182A	MY49060440	July 1, 2016	July 1, 2017
ESG Vector Signal Generator	Agilent	E4438C	MY45094064	July 1, 2016	July 1, 2017
Signal Generator	Agilent	E4432B	GB40050998	July 1, 2016	July 1, 2017
Semi Anechoic Civil Chamber	ETS	S81	SL 11643	N/A	N/A
Antenna Mast	ETS	2070-2	-	N/A	N/A
Turntable	ETS	2087	-	N/A	N/A
Mast & Table Controller	ETS/EMCO	2090	9608-1456	N/A	N/A

**Figure 64 Test Equipment Used**



# 11. Out-of-Band Rejection (AWS)

## 11.1 Test Specification

KDB 935210 D05 v01r01, Section 3.3

## 11.2 Test Procedure

(Temperature (21°C)/ Humidity (35%RH))

The E.U.T. antenna terminal was connected to the spectrum analyzer through an external attenuator and an appropriate coaxial cable (max Loss= 31.0 dB).

The signal and spectrum analyzer frequency range was set to  $\pm 250\%$  of the passband, Dwell time set to approximately 10msec.

RBW was set between 1% to 5% of the E.U.T passband and VBW set to  $\geq 3 * RBW$ .

## 11.3 Test Limit

N/A

## 11.4 Test Results

JUDGEMENT: Passed

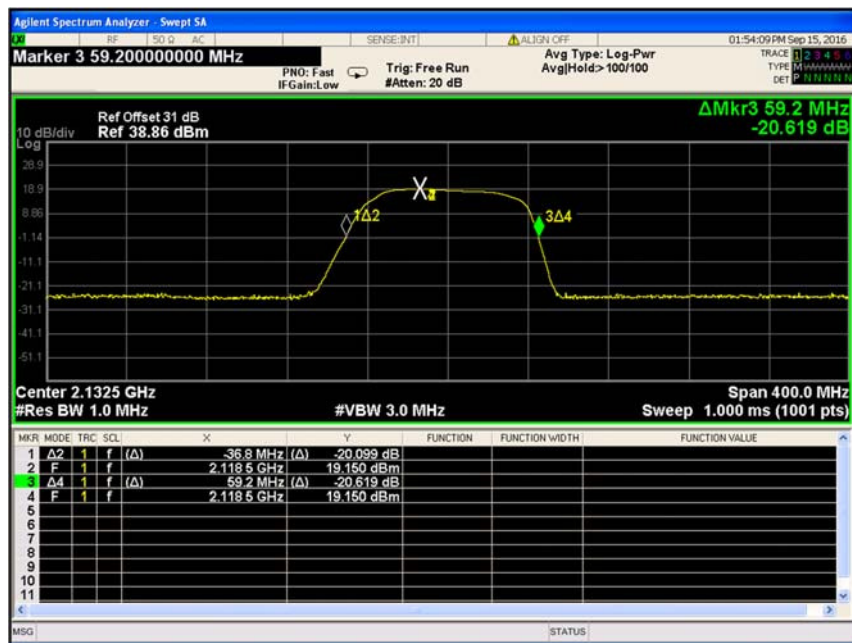

Figure 65. — Out-of-Band Rejection Plot



### 11.5 Test Equipment Used; Out-of-Band Rejection

Instrument	Manufacturer	Model	Serial Number	Calibration	
				Last Calibration Date	Next Calibration Date
EXA Spectrum Analyzer	Agilent	N9010A	MY48030391	March 16, 2016	March 16, 2018
EXG Vector Signal Generator	Agilent	N5172B	MY49060440	November 11, 2014	November 19, 2017
30 dB Attenuator	MCL	BW-S30W5	533	July 5, 2016	July 15, 2017

Figure 66 Test Equipment Used



## 12. APPENDIX A - CORRECTION FACTORS

### 12.1 Correction factors for *RF OATS Cable 35m* *ITL #1784*

Frequency ( MHz)	Cable loss (dB)
10.0	0.3
20.0	0.2
50.0	-0.1
100.0	-0.6
200.0	-1.2
500.0	-2.3
1000.0	-3.6



**12.2 Correction factors for RF OATS Cable 10m**

**ITL #1794**

Frequency(MHz)	Cable loss(dB)
10.0	-0.3
20.0	-0.3
50.0	-0.5
100.0	-0.7
200.0	-1.1
500.0	-1.8
1000.0	-2.7



### 12.3 Correction factors for RF CABLE for Semi Anechoic Chamber

ITL # 1841

FREQ (MHz)	LOSS (dB)
1000.0	1.5
2000.0	2.1
3000.0	2.7
4000.0	3.1
5000.0	3.5
6000.0	4.1
7000.0	4.6
8000.0	4.9
9000.0	5.7
10000.0	5.7
11000.0	6.1
12000.0	6.1
13000.0	6.2
14000.0	6.7
15000.0	7.4
16000.0	7.5
17000.0	7.9
18000.0	8.1
19000.0	8.8
20000.0	9.1

**NOTES:**

1. The cable is manufactured by Commscope
2. The cable type is 0623 WBC-400, serial # G020132 and 10m long





**12.4 Correction factors for Horn Antenna**

**Model: SWH-28  
at 1 meter range.**

<b>FREQUENCY (GHz)</b>	<b>AFE (dB /m)</b>	<b>Gain (dB1)</b>
18.0	40.3	16.1
19.0	40.3	16.3
20.0	40.3	16.1
21.0	40.3	16.3
22.0	40.4	16.8
23.0	40.5	16.4
24.0	40.5	16.6
25.0	40.5	16.7
26.0	40.6	16.4



**12.5 Correction factors for Horn ANTENNA**  
**Model: 3115**  
**Antenna serial number: 29845**  
**3 meter range**

f(GHz)	AF(dB/m)	GA(dB)
0.75	25	3
1G	23.5	7
1.5G	26	8
2G	29	7
2.5G	27.5	10
3G	30	10
3.5G	31.5	10
4G	32.5	9.5
4.5G	32.5	10.5
5G	33	10.5
5.5G	35	10.5
6G	36.5	9.5
6.5G	36.5	10
7G	37.5	10
7.5G	37.5	10
8G	37.5	11
8.5G	38	11
9G	37.5	11.5
9.5G	38	11.5
10G	38.5	11.5
10.5G	38.5	12
11G	38.5	12.5
11.5G	38.5	13
12G	38	13.5
12.5G	38.5	13
13G	40	12
13.5G	41	12
14G	40	13
14.5G	39	14
15G	38	15.5
15.5G	37.5	16
16G	37.5	16
16.5G	39	15
17G	40	15
17.5G	42	13.5
18G	42.5	13



**12.6 Correction factors for Log Periodic Antenna  
EMCO, Model 3146,  
Serial #9505-4081**

Frequency [MHz]	AF [dB/m]
200.0	11.47
250.0	12.06
300.0	14.77
400.0	15.77
500.0	18.01
600.0	18.84
700.0	20.93
800.0	21.27
900.0	22.44
1000.0	24.10



**12.7 Correction factors for Biconical Antenna  
EMCO, Model 3110B,  
Serial #9912-3337**

Frequency [MHz]	AF [dB/m]
30.0	14.18
35.0	13.95
40.0	12.84
45.0	11.23
50.0	11.10
60.0	10.39
70.0	9.34
80.0	9.02
90.0	9.31
100.0	8.95
120.0	11.53
140.0	12.20
160.0	12.56
180.0	13.49
200.0	15.27



**12.8 Correction factors for ACTIVE LOOP ANTENNA**  
**Model 6502**  
**S/N 9506-2950**

f(MHz)	MAF(dBs/m)	AF(dB/m)
0.01	-33.1	18.4
0.02	-37.2	14.3
0.03	-38.2	13.3
0.05	-39.8	11.7
0.1	-40.1	11.4
0.2	-40.3	11.2
0.3	-40.3	11.2
0.5	-40.3	11.2
0.7	-40.3	11.2
1	-40.1	11.4
2	-40	11.5
3	-40	11.5
4	-40.1	11.4
5	-40.2	11.3
6	-40.4	11.1
7	-40.4	11.1
8	-40.4	11.1
9	-40.5	11
10	-40.5	11
20	-41.5	10
30	-43.5	8