

### 7.2.3 Band Edge & Intermodulation

Test Date: 2012-05-02

Test Requirement: FCC part 22.917(b) & FCC part 27.53(h)

22.917(b) Measurement procedure. Compliance with these rules is based on the use of measurement instrumentation employing a resolution bandwidth of 100 kHz or greater. In the 1 MHz bands immediately outside and adjacent to the frequency block a resolution bandwidth of at least one percent of the emission bandwidth of the fundamental emission of the transmitter may be employed. A narrower resolution bandwidth is permitted in all cases to improve measurement accuracy provided the measured power is integrated over the full required measurement bandwidth ( i.e. 100 kHz or 1 percent of emission bandwidth, as specified). The emission bandwidth is defined as the width of the signal between two points, one below the carrier center frequency and one above the carrier center frequency, outside of which all emissions are attenuated at least 26 dB below the transmitter power.

27.53(h) Compliance with this provision is based on the use of measurement instrumentation employing a resolution bandwidth of 1 megahertz or greater. However, in the 1 megahertz bands immediately outside and adjacent to the licensee's frequency block, a resolution bandwidth of at least one percent of the emission bandwidth of the fundamental emission of the transmitter may be employed. The emission bandwidth is defined as the width of the signal between two points, one below the carrier center frequency and one above the carrier center frequency, outside of which all emissions are attenuated at least 26 dB below the transmitter power.

Test Method: FCC part 2.1051&2-11-04/EAB/RF

EUT Operation:

Status: Drive the EUT to maximum output power.

Conditions: Normal conditions

Application: Cellular Band RF output ports

Test Configuration:

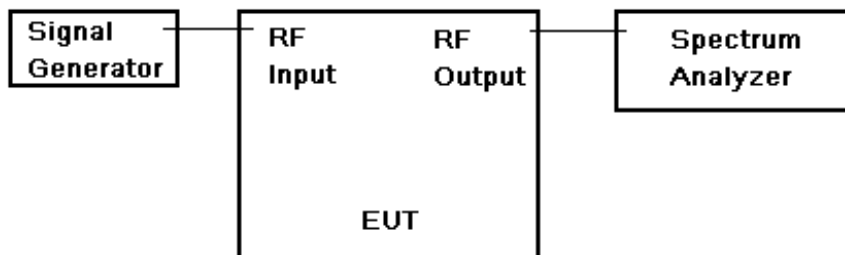
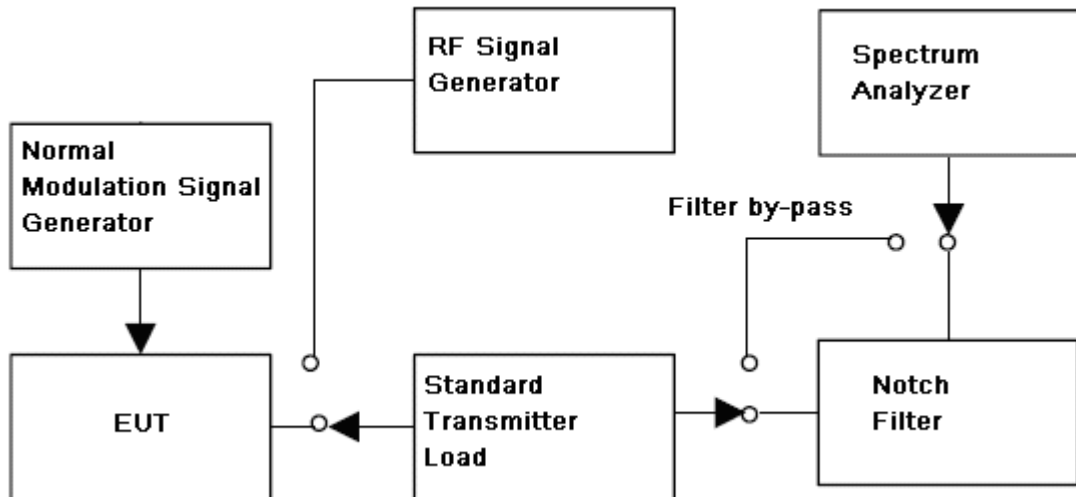

Fig.3. Band edge and Intermodulation test configuration



Test Procedure:

Conducted Emissions test procedure:

- a) Connect the equipment as illustrated, with the notch filter by-passed, when the output power is over the max value of the Spectrum Analyzer, add the attenuator to avoid destroying the facility.
- b) Set the center frequency of the spectrum analyzer to the assigned transmitter frequency, key the transmitter, and set the level of the carrier to the full scale reference line.
- c) do not apply any tone to modulate the EUT.
- d) Adjust the spectrum analyzer for the following settings:
  - 1) Resolution Bandwidth, (base the standard, apply the different set), here is 100KHz for frequency band less than 1GHz, 1MHz for frequency over 1GHz;
  - 2) Video Bandwidth refer to standard requirement.
- e) Adjust the center frequency of the spectrum analyzer for incremental coverage of the range from:
  - 1) the lowest radio frequency generated in the equipment, it can be 9KHz base the test method, here select 30MHz as lowest frequency start point;
  - 2) the highest radion frequency shall higher than 10 times of carrier frequency;
- f) Record the frequencies and levels of spurious emissions from step e)

Remark:

The notch filter is used for avoid the EUT fundamental carrier output power making the spectrum overload and the harmonic spurious brought by it.

When the EUT fundamental carrier is not enough to make the status, the notch filter could be not used.



Intermodulation

Test Procedure:

1. Connect the equipment as illustrated;
2. Test the background noise level with all the test facilities;
3. Keep one transmitting path, all other connectors shall be connected by normal power or RF leads;
4. Select the attenuator to avoid the test receiver or spectrum analyzer being destroyed;
5. Keep the EUT continuously transmitting in max power;
6. Keep two signals are same in modulation type and level;
7. Measure the 3 order intermodulated product by the EUT( the sum of the two unwanted signal should be rated power);
8. Correct for all losses in the RF path;
9. Read the conducted spurious emissioins of the EUT antenna port.

Remark:

- At maximum drive level, for each modulation: one test with three tones, or two tests (high-, low-band edge) with two tones
- Limit usually is -13dBm conducted.
- Not needed for Single Channel systems.



7.2.3.1 Measurement Record:

1. Test for CDMA:

1.1 one signal input downlink(869MHz to 894MHz)– Lower Edge

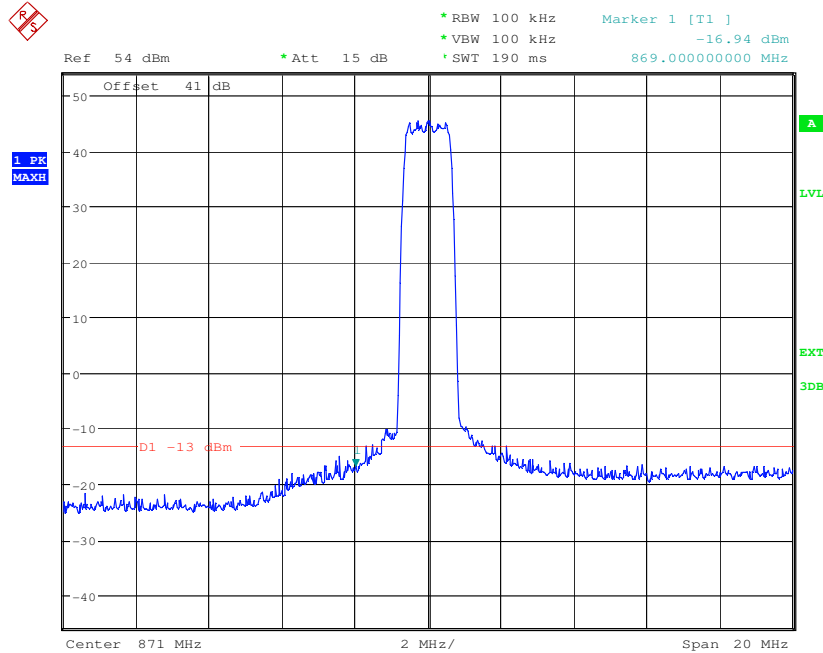

1.2 one signal input downlink(869MHz to 894MHz)– Upper Edge

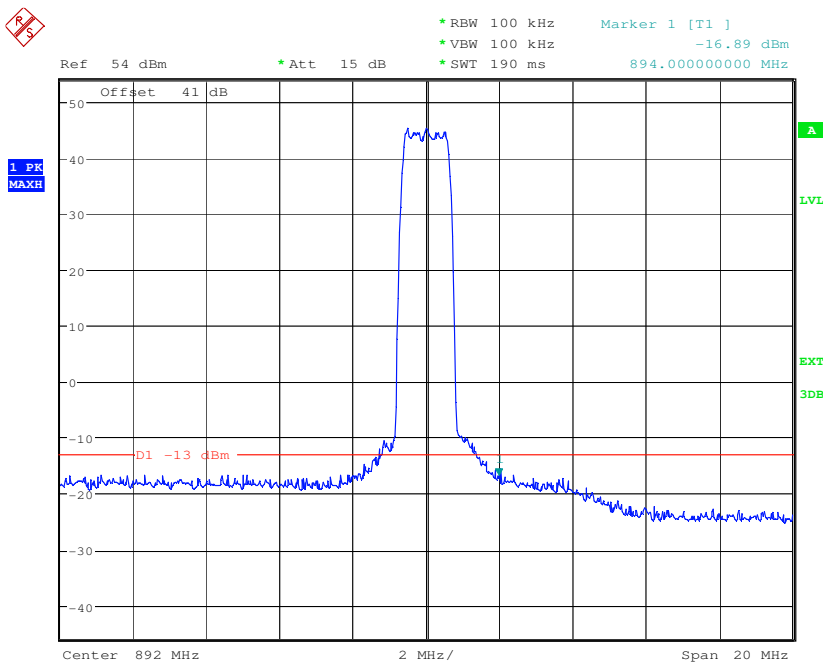



1.3 two signal input downlink(869MHz to 894MHz)—Lower Edge

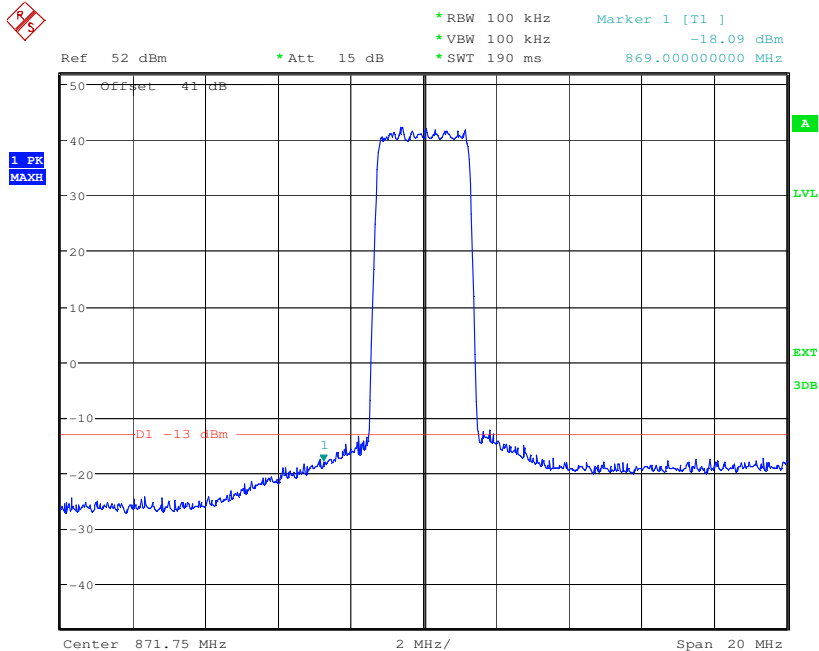

1.4 two signal input downlink(869MHz to 894MHz)—Upper Edge

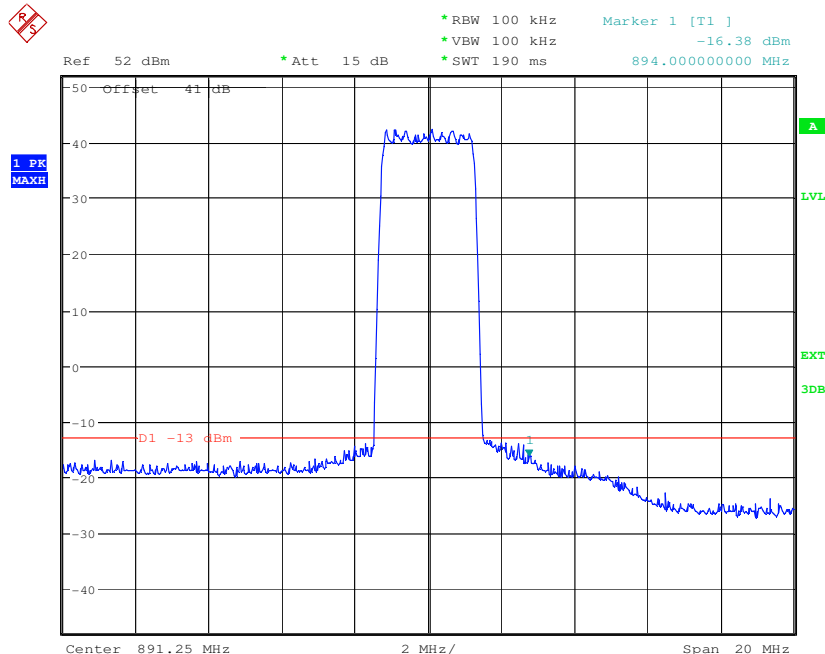



## 2. Test for WCDMA:

### 2.1 one signal input downlink(869MHz to 894MHz)– Lower Edge

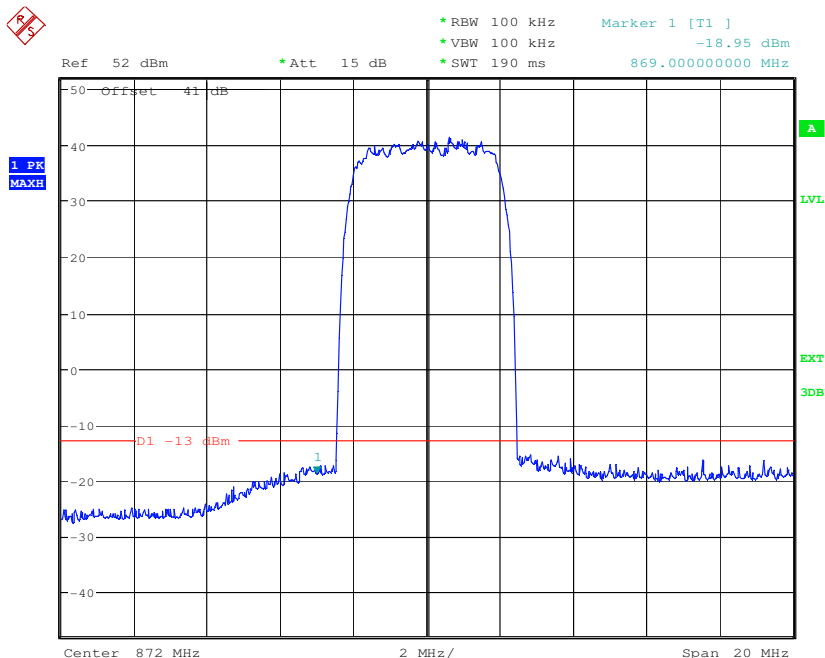

### 2.2 one signal input downlink(869MHz to 894MHz)– Upper Edge

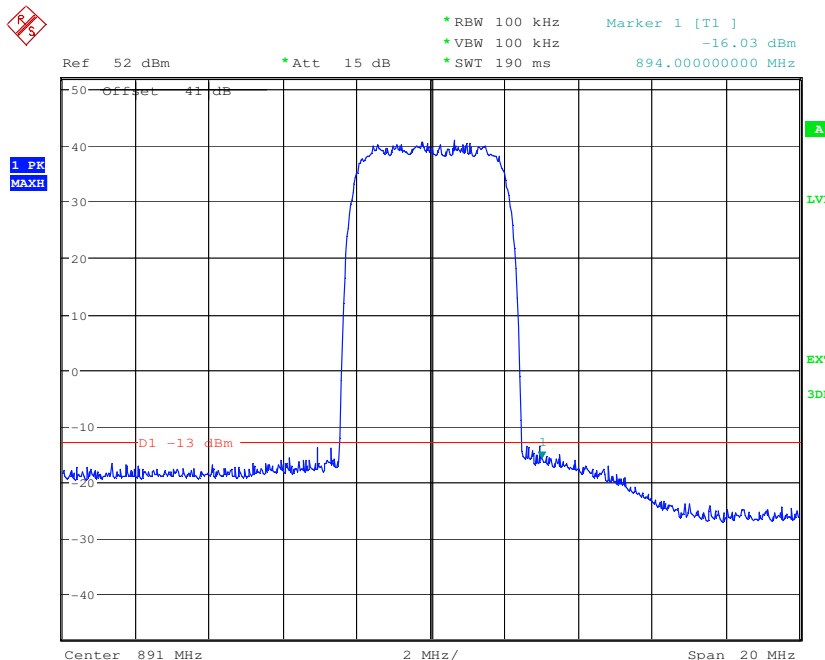



2.3 two signal input downlink(869MHz to 894MHz)—Lower Edge

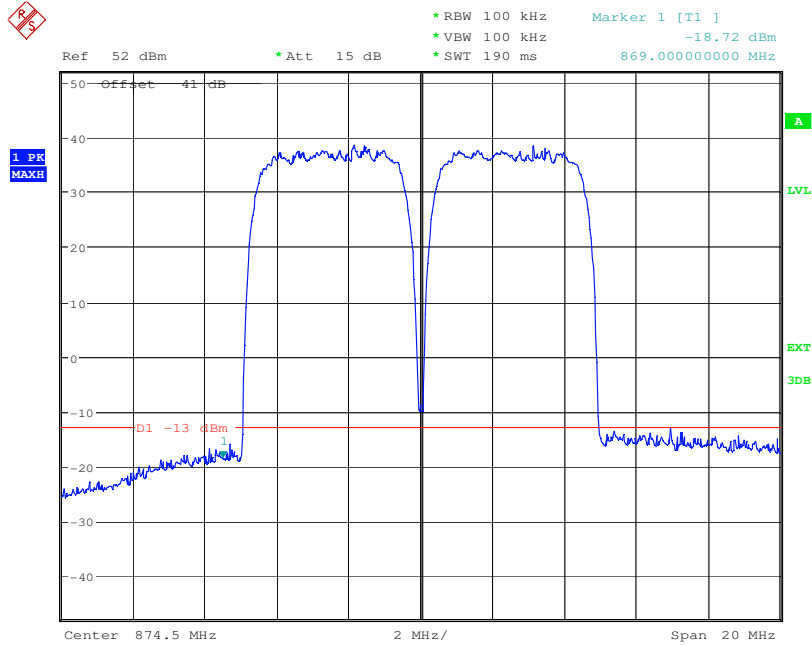

2.4 two signal input downlink(869MHz to 894MHz)—Upper Edge

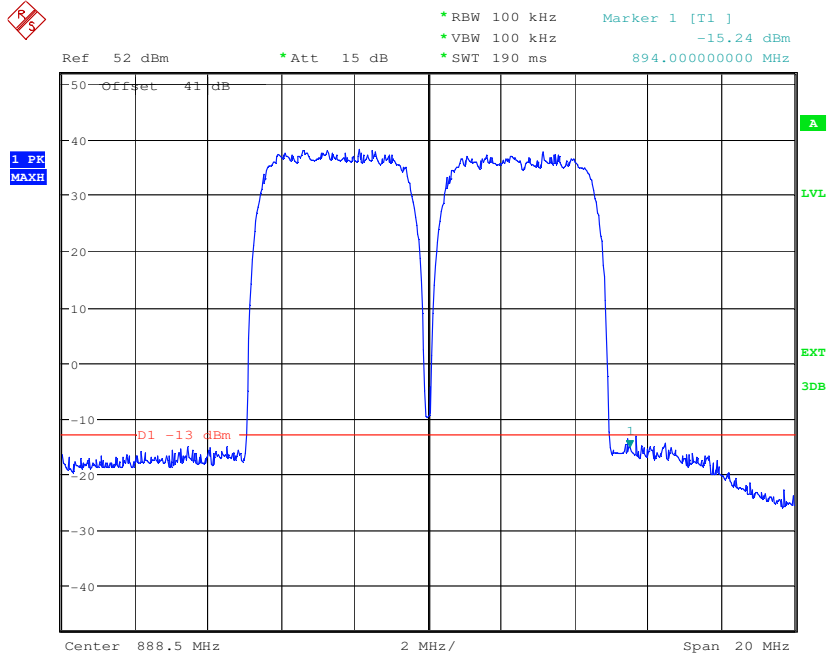



2.5 one signal input downlink(2110MHz to 2155MHz)– Lower Edge

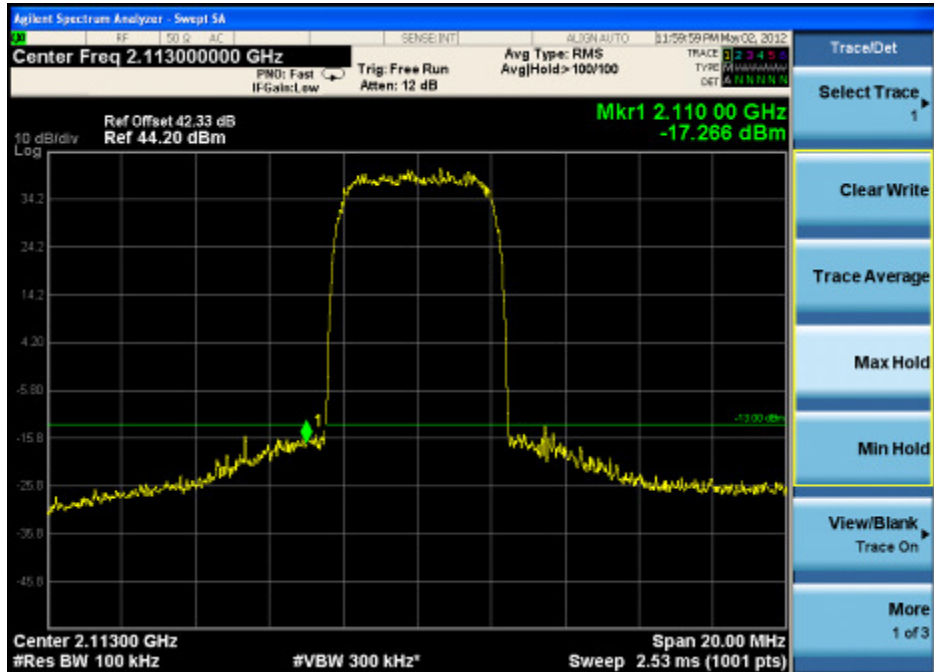

2.6 one signal input downlink(2110MHz to 2155MHz)– Upper Edge

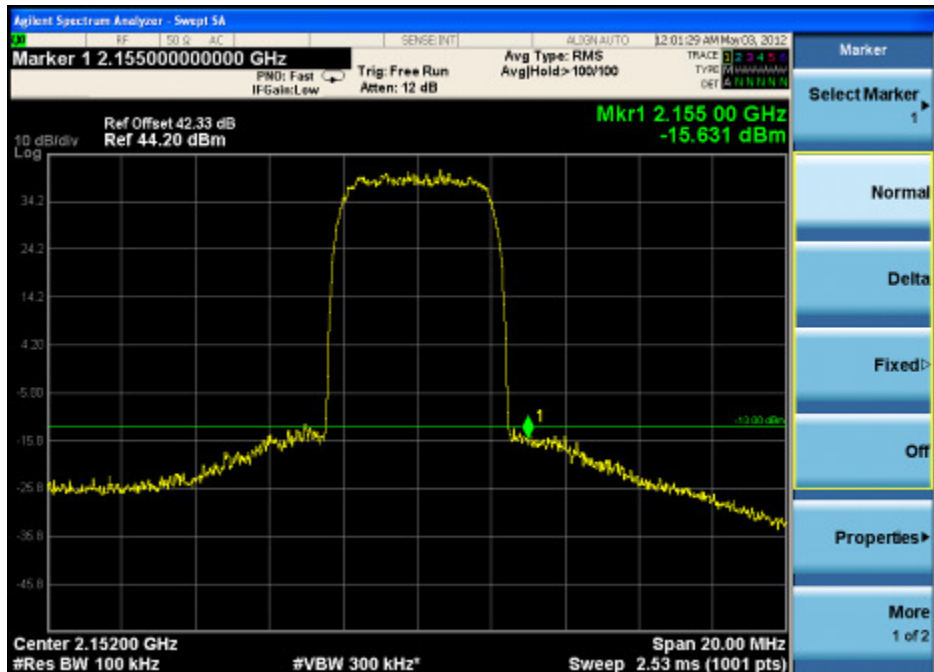



2.7 two signal input downlink(2110MHz to 2155MHz)—Lower Edge

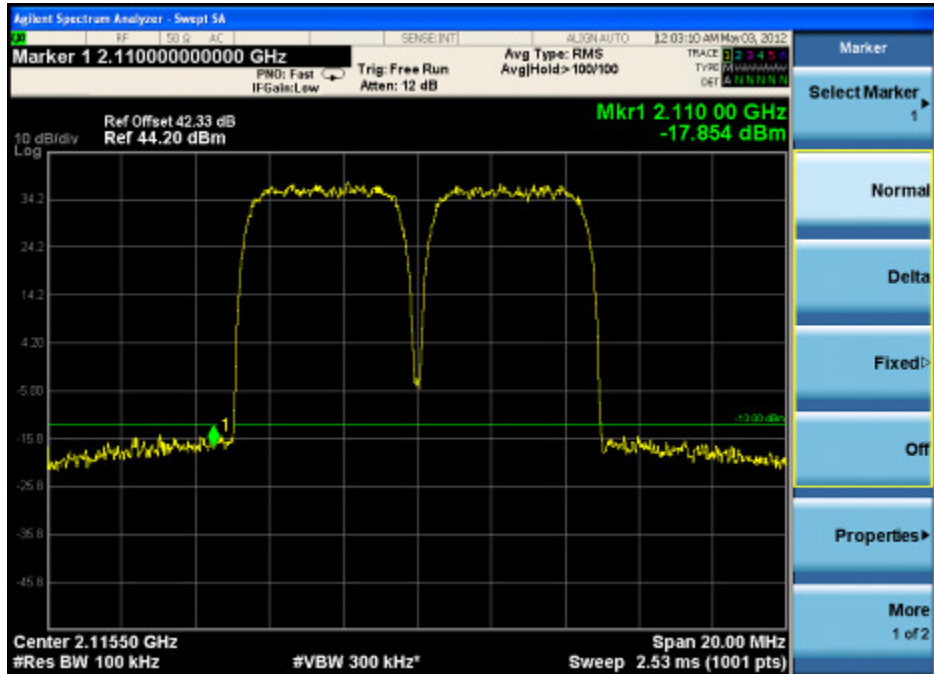

2.8 two signal input downlink(2110MHz to 2155MHz)—Upper Edge

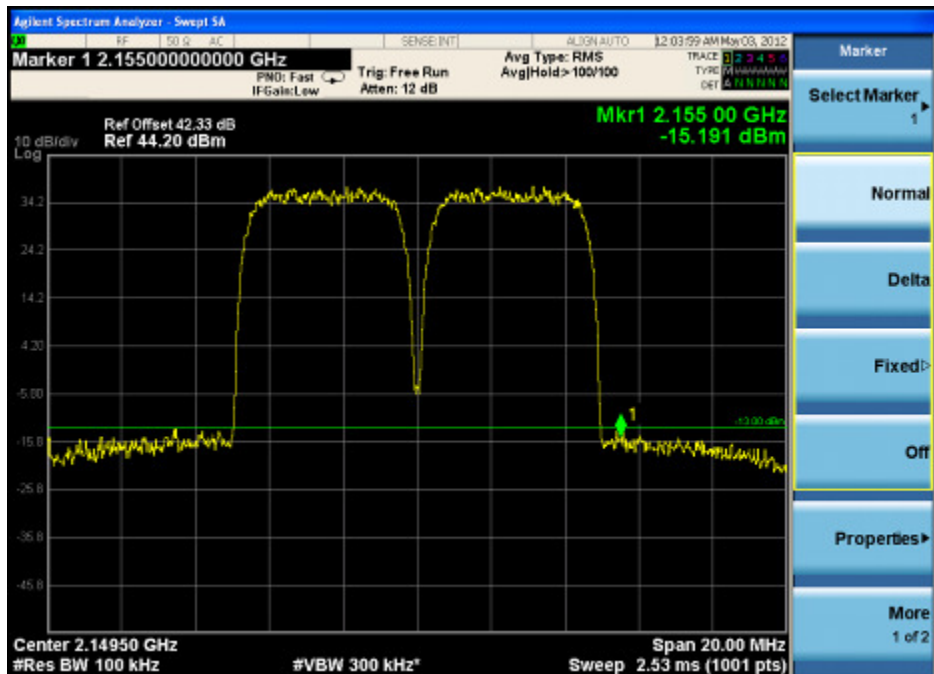



### 3. Test for GSM:

#### 3.1 one signal input downlink(869MHz to 894MHz)– Lower Edge

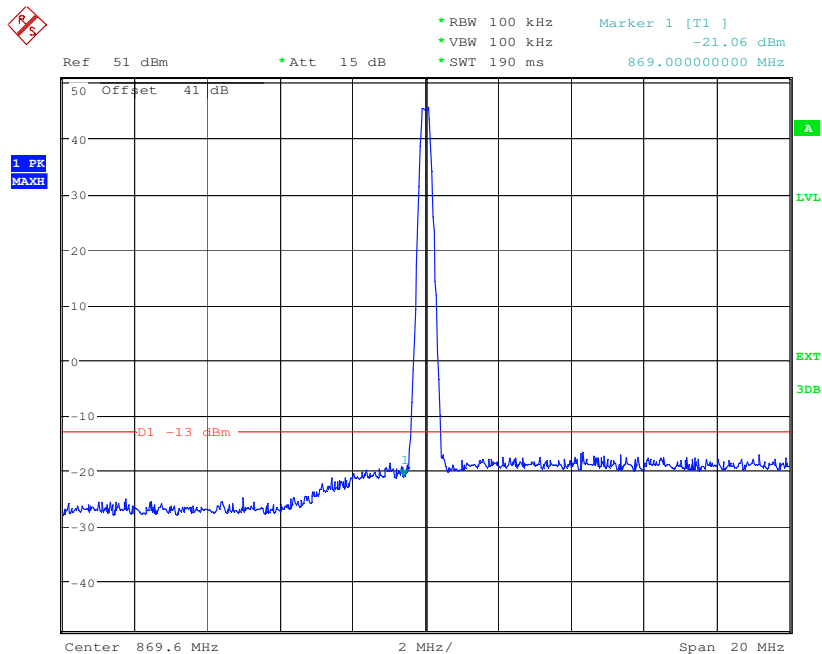

#### 3.2 one signal input downlink(869MHz to 894MHz)– Upper Edge

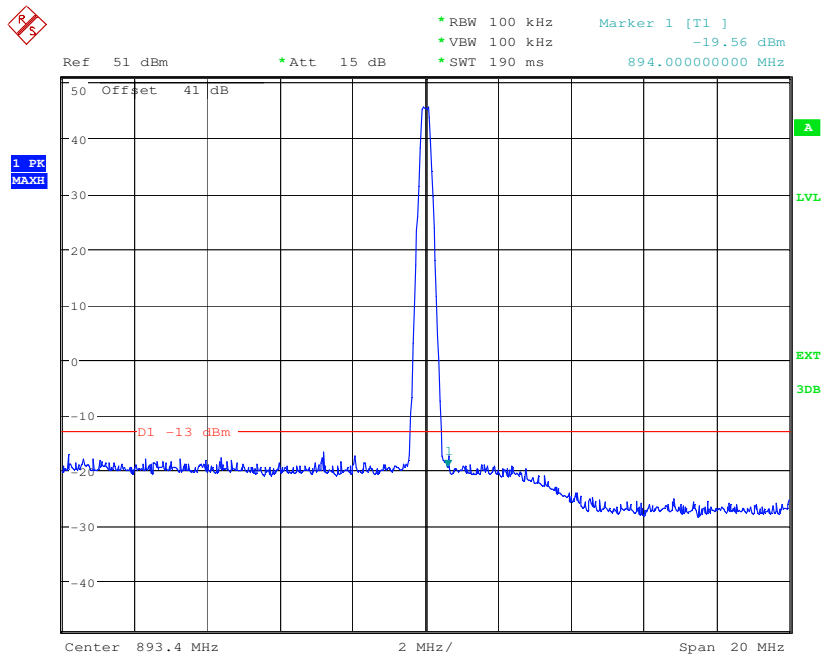



3.3 two signal input downlink(869MHz to 894MHz)—Lower Edge

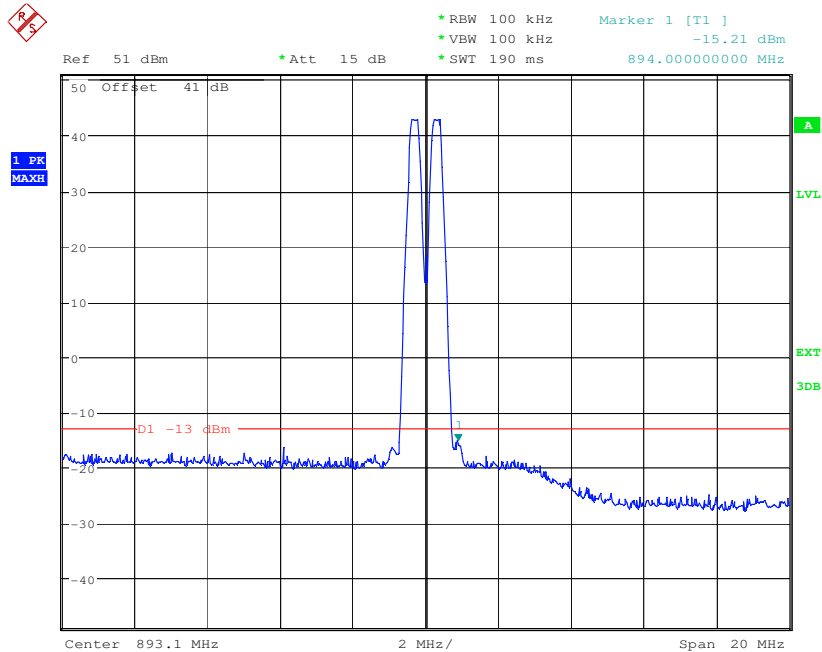

3.4 two signal input downlink(869MHz to 894MHz)—Upper Edge

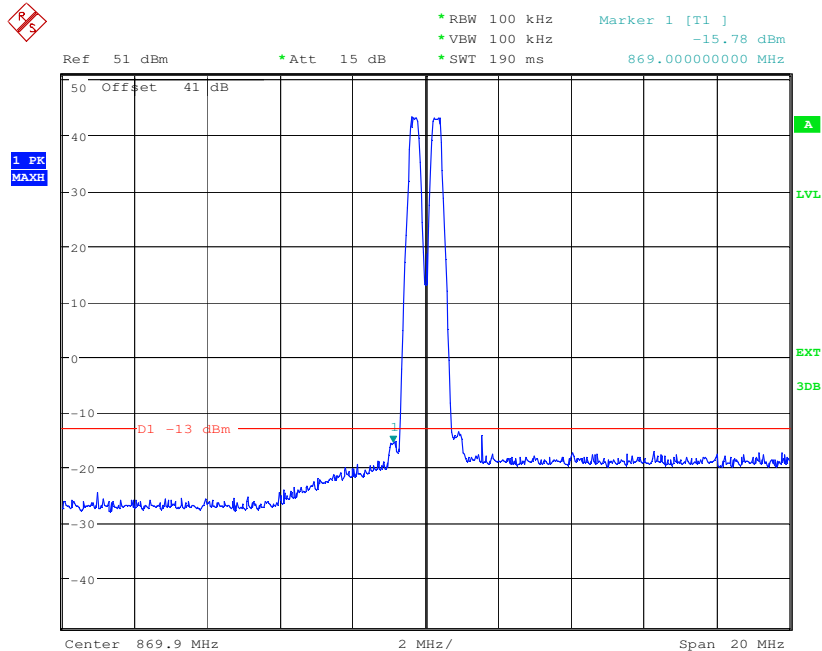

4. Test for LTE:

4.1 one signal input downlink(728MHz to 757MHz)– Lower Edge

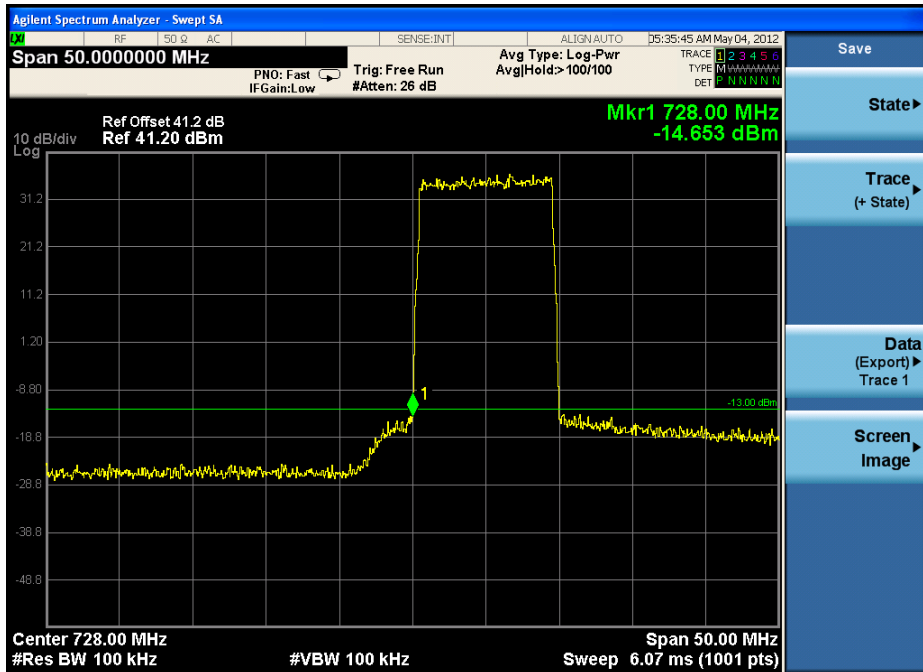

4.2 one signal input downlink(728MHz to 757MHz)– Upper Edge

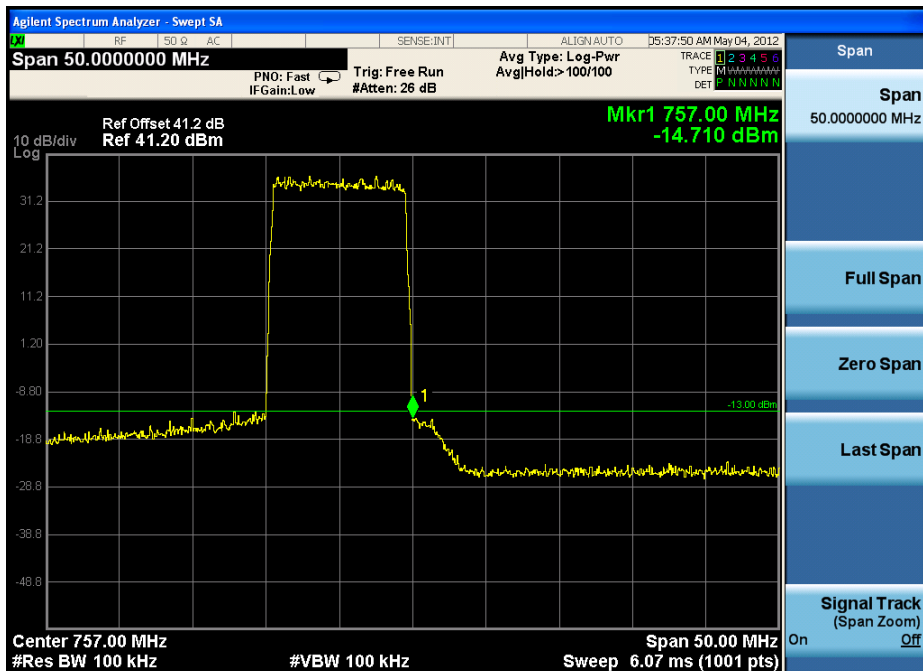



4.3 two signal input downlink(728MHz to 757MHz)Lower Edge

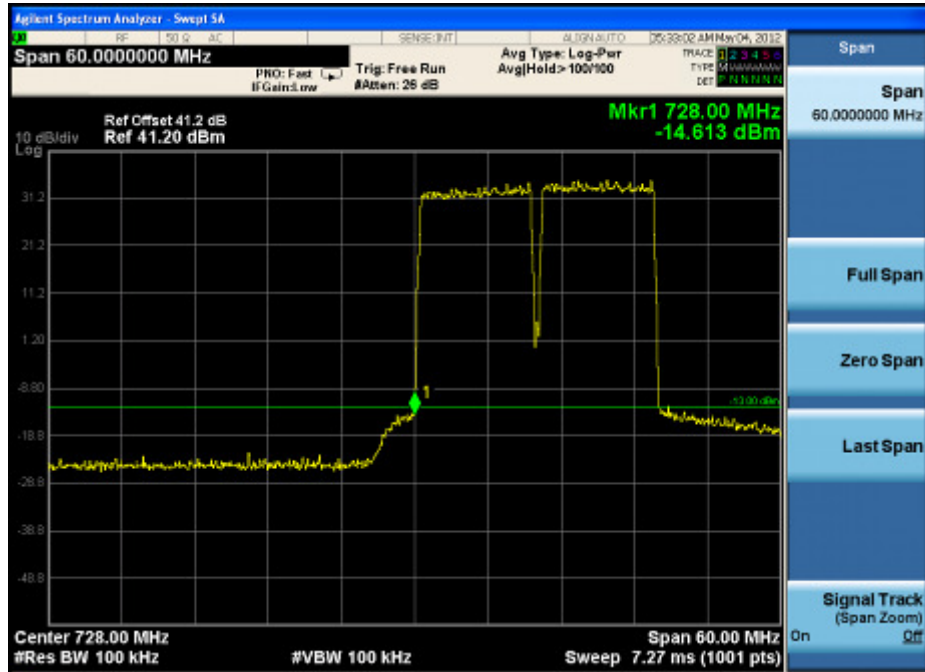

4.4 two signal input downlink(728MHz to 757MHz)—Upper Edge

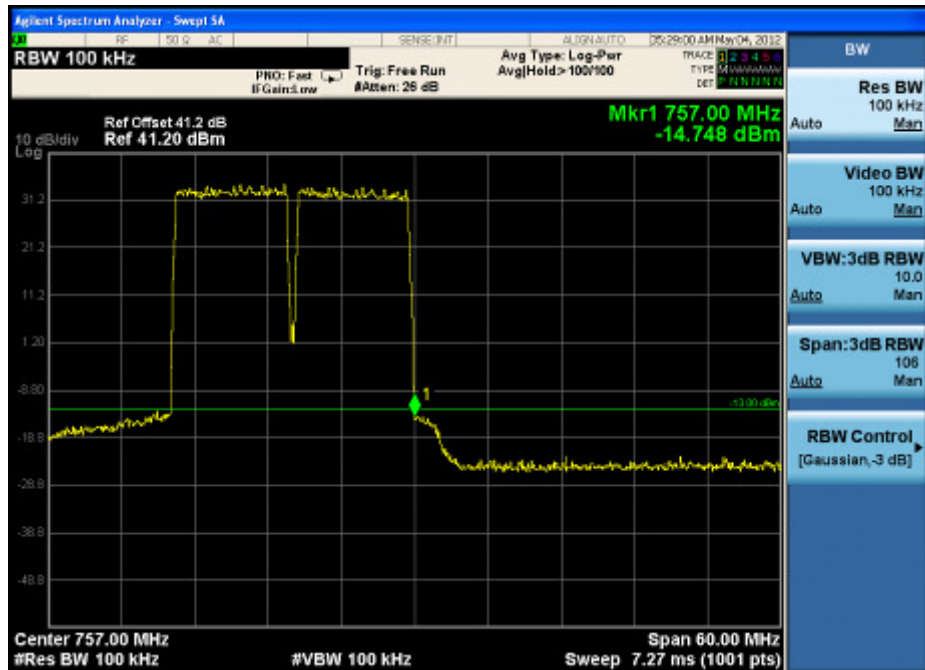



4.5 one signal input downlink(869MHz to 894MHz)– Lower Edge

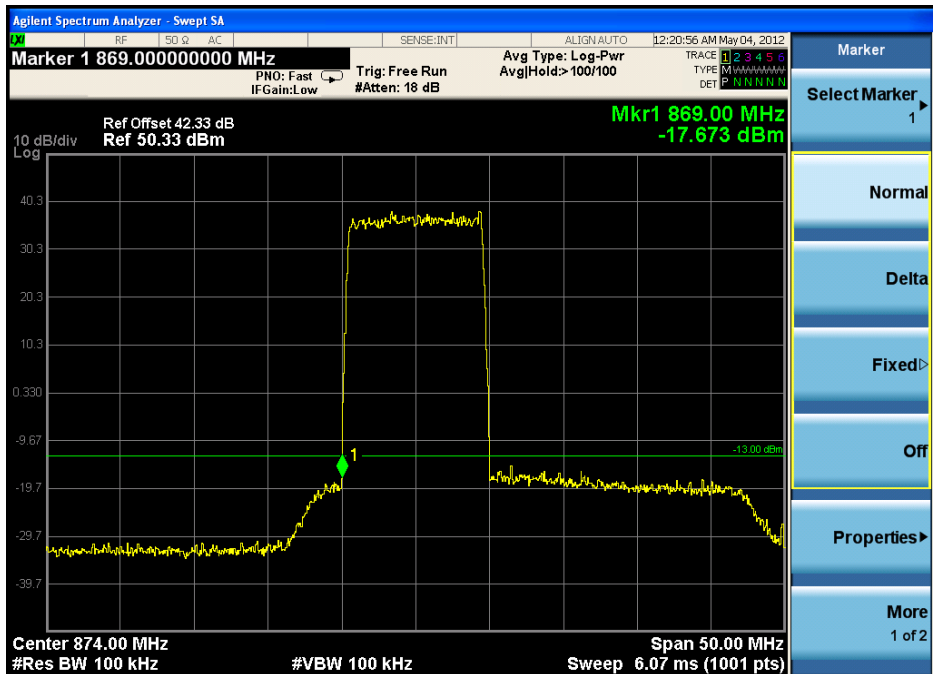

4.6 one signal input downlink(869MHz to 894MHz)– Upper Edge

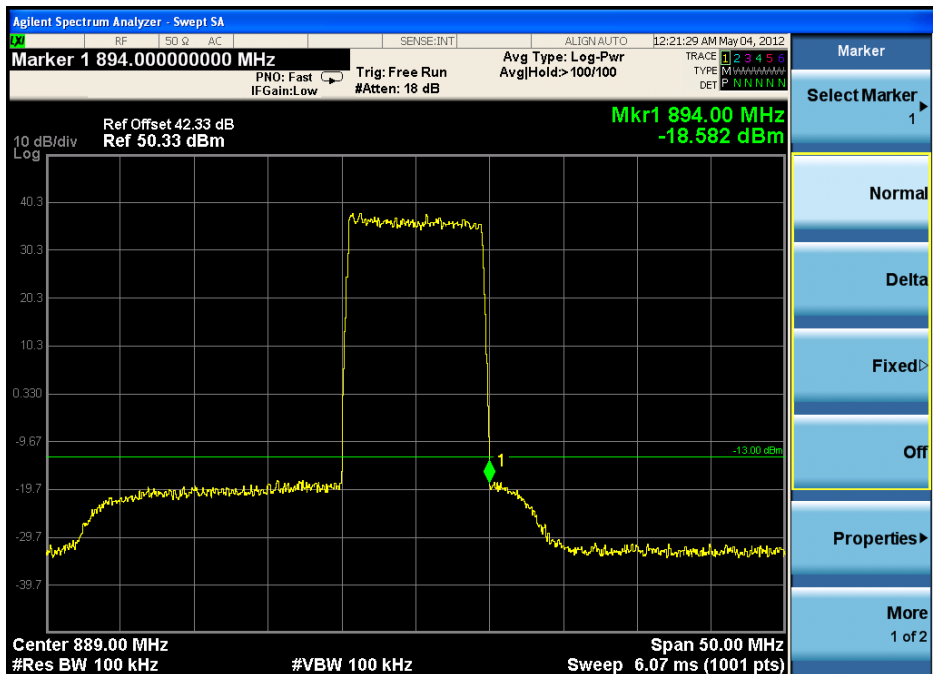



4.7 two signal input downlink(869MHz to 894MHz)Lower Edge

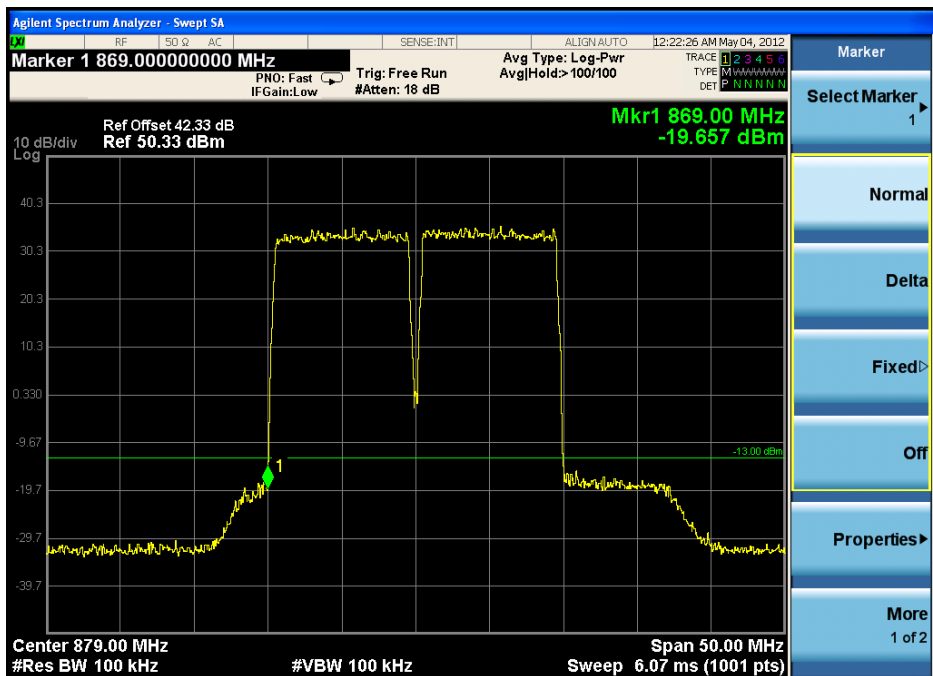

4.8 two signal input downlink(869MHz to 894MHz)—Upper Edge

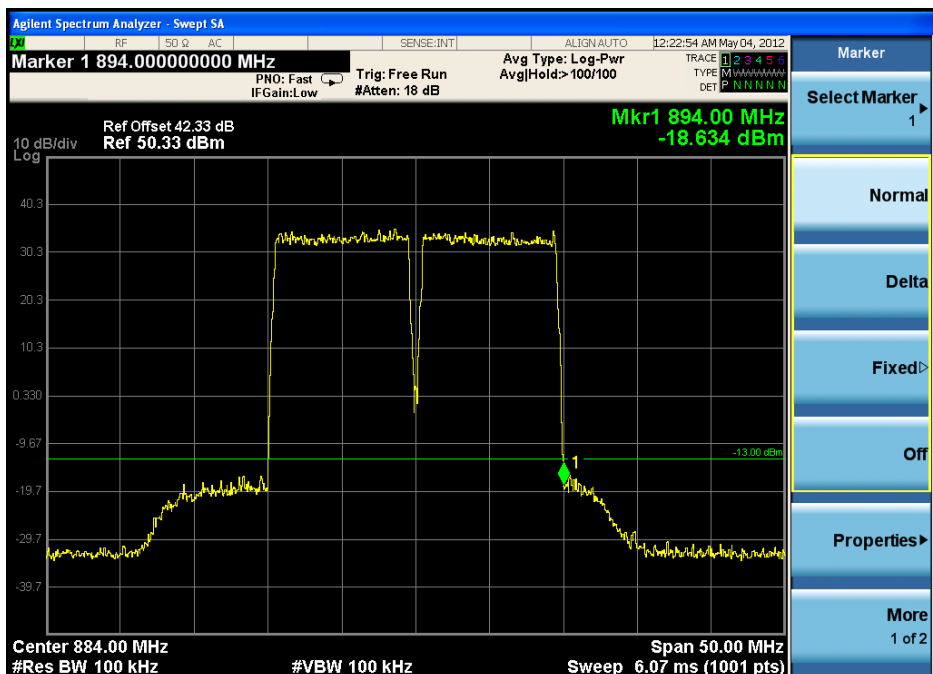



4.9 one signal input downlink(2110MHz to 2155MHz)– Lower Edge

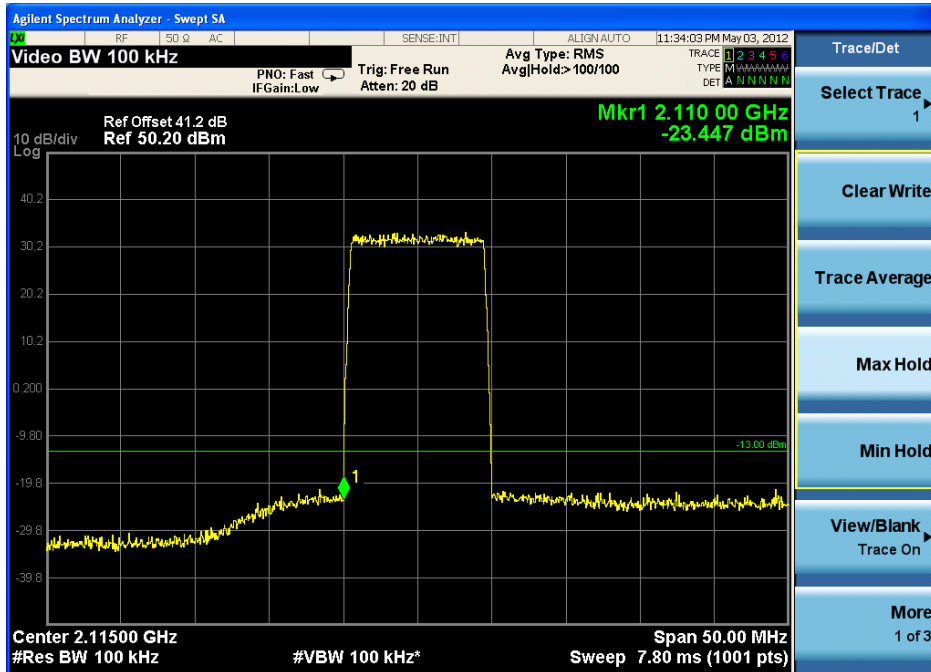

4.10 one signal input downlink(2110MHz to 2155MHz)– Upper Edge

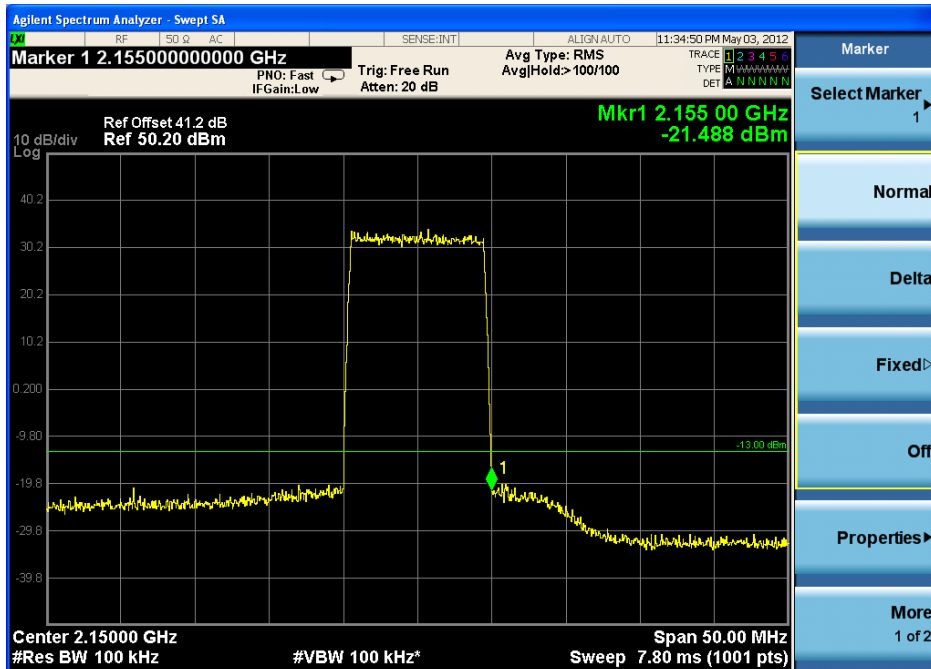





4.11 two signal input downlink(2110MHz to 2155MHz)Lower Edge

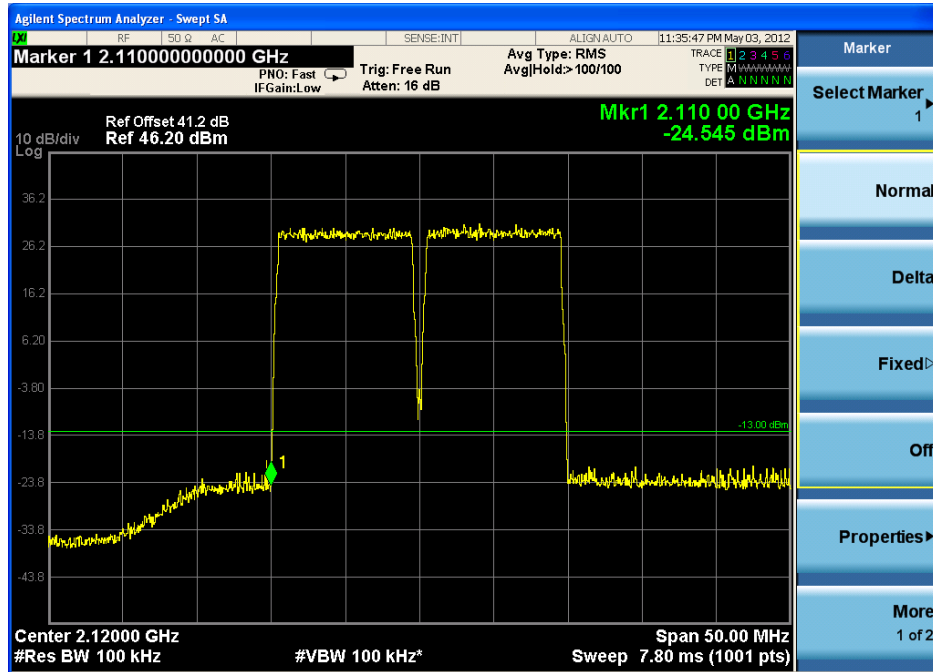

4.12 two signal input downlink(2110MHz to 2155MHz)—Upper Edge

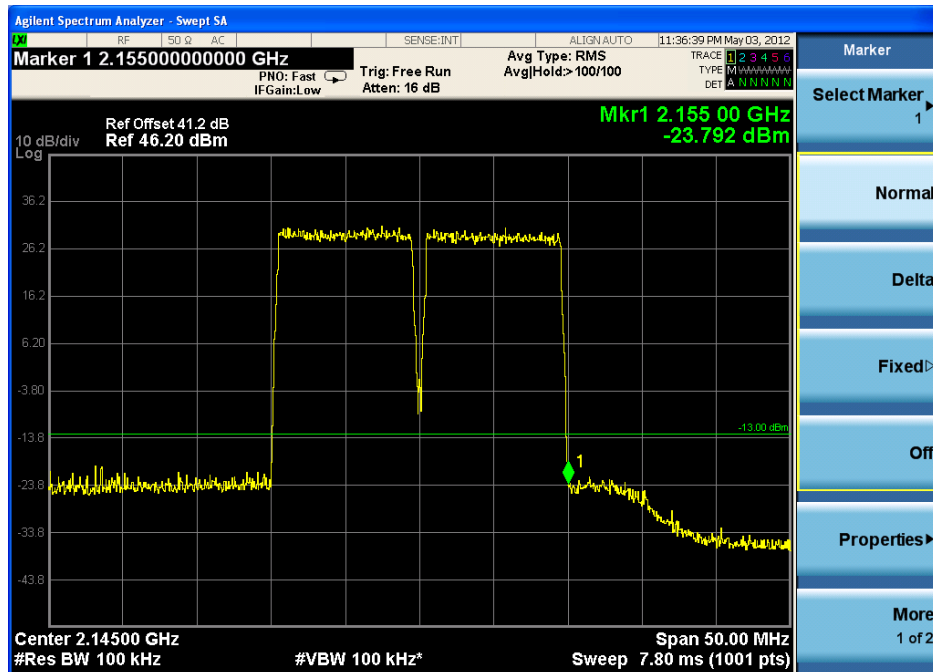



Remark:

For the test in two signal input or intermodulation, test input signal f1 and f2 will consider as follows conditions:

- 1) EUT frequency band span and the amount of channels;
- 2) f1 is the frequency lower, f2 is the frequency higher,  $\Delta f$  is the channel spacing;
- 3) in lower edge test, f1 is the lower edge frequency +1 channel frequency, and f2 is +2 channel frequency;
- 4) in higher edge test, f1 is the higher edge frequency -2 channel frequency, and f2 is -1 channel frequency;
- 5) according to the amplifier characteristic, the 3<sup>rd</sup> product will appear when two signals input;
- 6) base the 3<sup>rd</sup> product frequency  $F1=2f1-f2$  and  $F2=2f2-f1$ , when the f1 and f2 frequency select above,
  - a) in lower edge test,  $F1=2f1-(f1+\Delta f)=f1-\Delta f$ =lower edge frequency;
  - b) in higher edge test,  $F2=2f2-(f2-\Delta f)=f2+\Delta f$ =higher edge frequency.

### 7.2.4 Radiated Spurious Emissions

Test Date: 2012-05-09

Test Requirement: FCC part 22.917(a) & FCC part 27.53(h)  
 22.917(a) Out of band emissions. The power of any emission outside of the authorized operating frequency ranges must be attenuated below the transmitting power (P) by a factor of at least  $43 + 10 \log(P)$  dB.

27.53(h) For operations in the 1710–1755 MHz and 2110–2155 MHz bands, the power of any emission outside a licensee's frequency block shall be attenuated below the transmitter power (P) by at least  $43 + 10 \log_{10}(P)$  dB.

Test Method: FCC part 2.1053  
 ANSI/TIA-603-C-2004

EUT Operation:  
 Status: Drive the EUT to maximum output power.  
 Conditions: Normal conditions  
 Application: Enclosure

Test Configuration:

30MHz to 1GHz emissions:

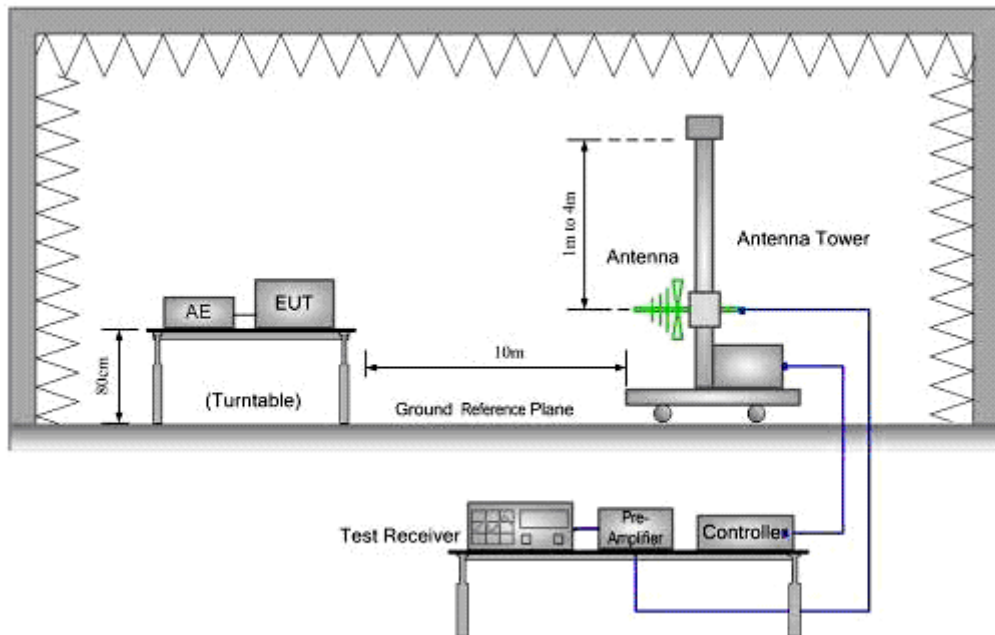

1GHz to 40GHz emissions:

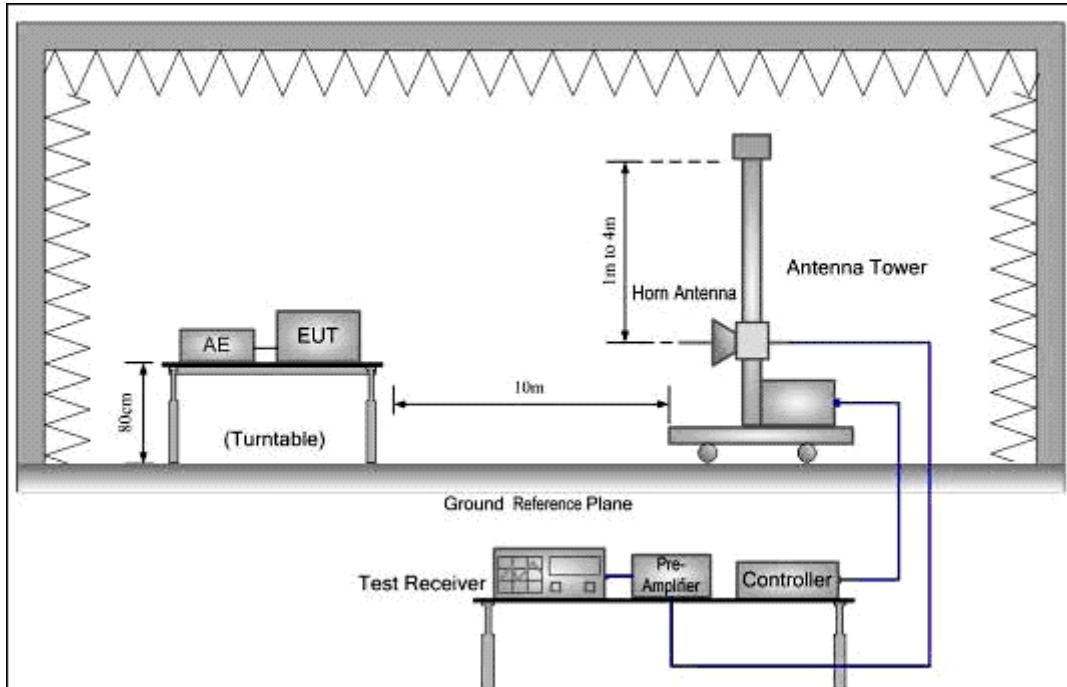

Test Procedure:

1. Test the background noise level with all the test facilities;
2. Keep one transmitting path, all other connectors shall be connected by normal power or RF leads;
3. Select the suitable RF notch filter to avoid the test receiver or spectrum analyzer produce unwanted spurious emissions;
4. Keep the EUT continuously transmitting in max power;
5. Read the radiated emissions of the EUT enclosure.

Radiated Emissions Test Procedure:

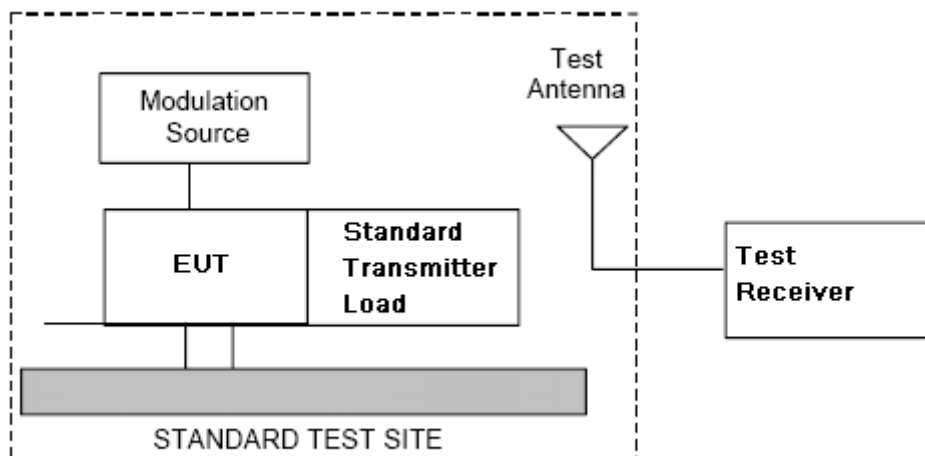

- a) Connect the equipment as illustrated.
- b) Adjust the spectrum analyzer for the following settings:
  - 1) Resolution Bandwidth = 100 kHz for spurious emissions below 1 GHz, and 1 MHz for spurious emissions above 1GHz.
  - 2) Video Bandwidth = 300 kHz for spurious emissions below 1 GHz, and 3 MHz for spurious emissions above 1 GHz.
  - 3) Sweep Speed slow enough to maintain measurement calibration.
  - 4) Detector Mode = Positive Peak.
- c) Place the transmitter to be tested on the turntable in the standard test site, The transmitter is transmitting into a nonradiating load that is placed on the turntable. The RF cable to this load should be of minimum length.
- d) Measurements shall be made from 30MHz to 10 times of fundamental carrier, except for the region close to the carrier equal to  $\pm$  the carrier bandwidth.
- e) Key the transmitter without modulation or normal modulation base the standard.
- f) For each spurious frequency, raise and lower the test antenna from 1 m to 4 m to obtain a maximum reading on the spectrum analyzer with the test antenna at horizontal polarity. Then the turntable should be rotated 360° to determine the maximum reading. Repeat this procedure to obtain the highest possible reading. Record this maximum reading.
- g) Repeat step f) for each spurious frequency with the test antenna polarized vertically.

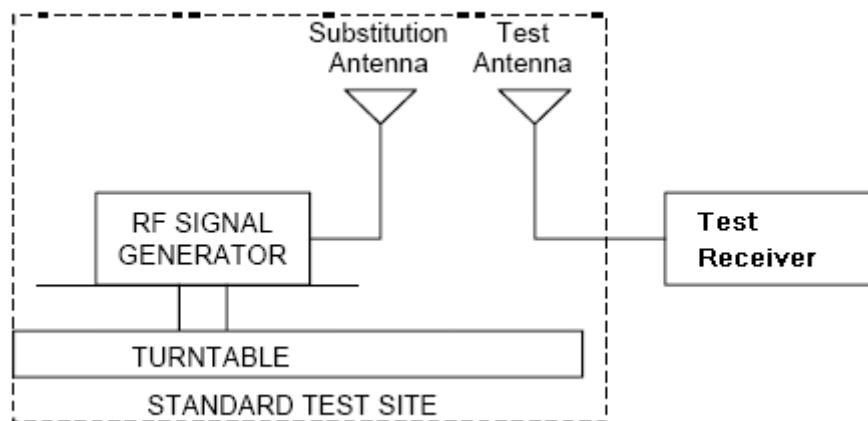



- h) Reconnect the equipment as illustrated.
- i) Keep the spectrum analyzer adjusted as in step b).
- j) Remove the transmitter and replace it with a substitution antenna (the antenna should be half-wavelength for each frequency involved). The center of the substitution antenna should be approximately at the same location as the center of the transmitter. At the lower frequencies, where the substitution antenna is very long, this will be impossible to achieve when the antenna is polarized vertically. In such case the lower end of the antenna should be 0.3 m above the ground.
- k) Feed the substitution antenna at the transmitter end with a signal generator connected to the antenna by means of a nonradiating cable. With the antennas at both ends horizontally polarized, and with the signal generator tuned to a particular spurious frequency, raise and lower the test antenna to obtain a maximum reading at the spectrum analyzer. Adjust the level of the signal generator output until the previously recorded maximum reading for this set of conditions is obtained. This should be done carefully repeating the adjustment of the test antenna and generator output.
- l) Repeat step k) with both antennas vertically polarized for each spurious frequency.
- m) Calculate power in dBm into a reference ideal half-wave dipole antenna by reducing the readings obtained in steps k) and l) by the power loss in the cable between the generator and the antenna, and further corrected for the gain of the substitution antenna used relative to an ideal half-wave dipole

antenna by the following formula:

$$Pd(\text{dBm}) = Pg(\text{dBm}) - \text{cable loss (dB)} + \text{antenna gain (dB)}$$

where:

$Pd$  is the dipole equivalent power and

$Pg$  is the generator output power into the substitution antenna.

NOTE: It is permissible to use other antennas provided they can be referenced to a dipole.

NOTE: Effective radiated power (e.r.p) refers to the radiation of a half wave tuned dipole instead of an isotropic antenna. There is a constant difference of 2.15 dB between e.i.r.p. and e.r.p.

$$e.r.p (\text{dBm}) = e.i.r.p. (\text{dBm}) - 2.15$$



#### **7.2.4.1 Measurement Record:**

No emissions were detected within 20dB below the limit for the Downlink direction.

#### **Remark:**

The cabinet radiation was measured with the equipment transmitting a CW signal into a non-radiating 50 Ohm load at maximum output power on a signal frequency .

Measured were performed in the lowest, middle and highest frequency for : the Downlink.

The spectrum was searched from 30MHz to 26GHz (10th Harmonic) for downlink;

### 7.2.5 Occupied Bandwidth

Test Date: 2012-05-02 to 2012-05-03

Test Requirement: 2-11-04/EAB/RF

Test Method: FCC part 2.1049, 2-11-04/EAB/RF

The spectral shape of the output should look similar to input for all modulations.

EUT Operation:

Status: Drive the EUT to maximum output power. .

Conditions: Normal conditions

Application: Cellular Band RF output ports

Test Configuration:

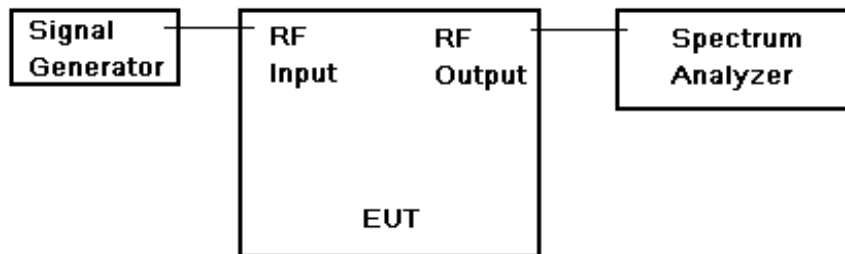

Fig.2. Conducted Spurious Emissions test configuration

- Test Procedure:
- a) Set the spectrum analyzer RBW 300 Hz or  $>1\% & < 2\%$  emission bandwidth of carrier.
  - b) Capture the trace of input signal;
  - c) Connect the equipment as illustrated;
  - d) Capture the trace of output signal;





7.2.5.1 Measurement Record:

1. Test for CDMA:

1.1 Downlink:869MHz to 894MHz(lowest frequency) – Input

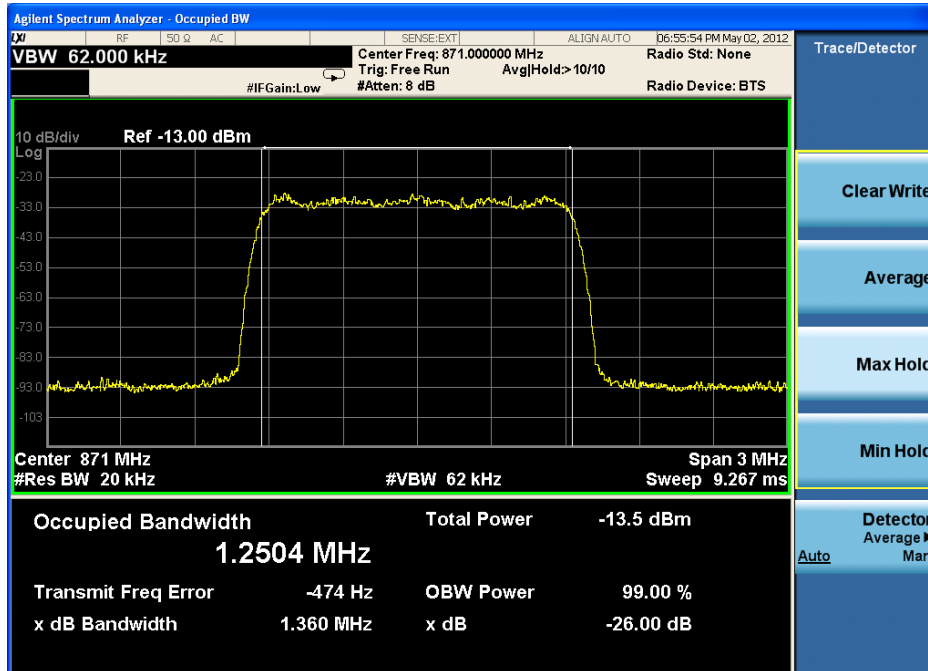

1.2 Downlink:869MHz to 894MHz (lowest frequency)-- Output

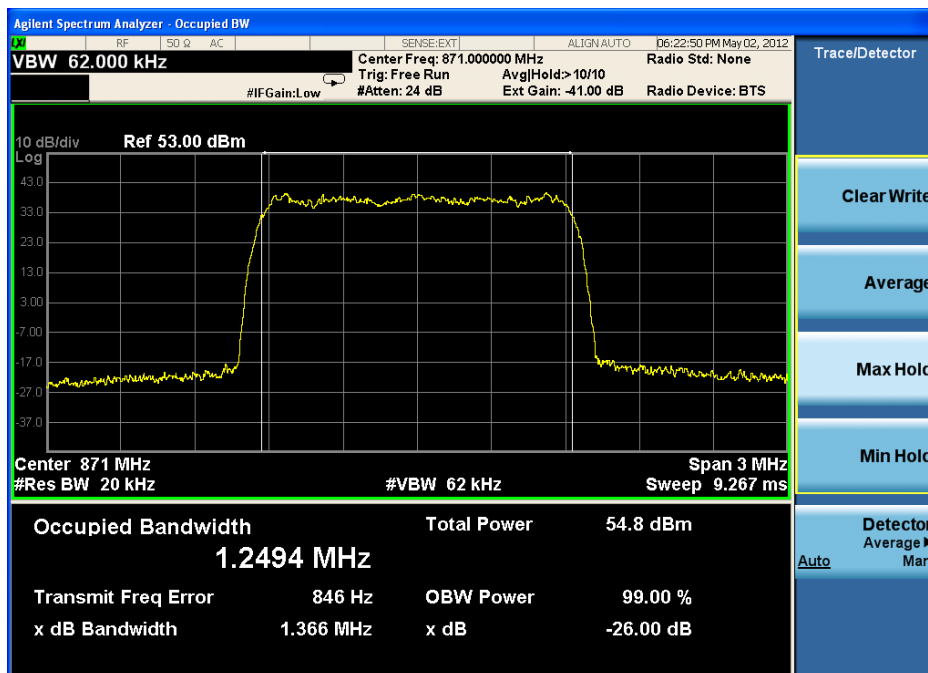



1.3 Downlink:869MHz to 894MHz (middle frequency)-- Input

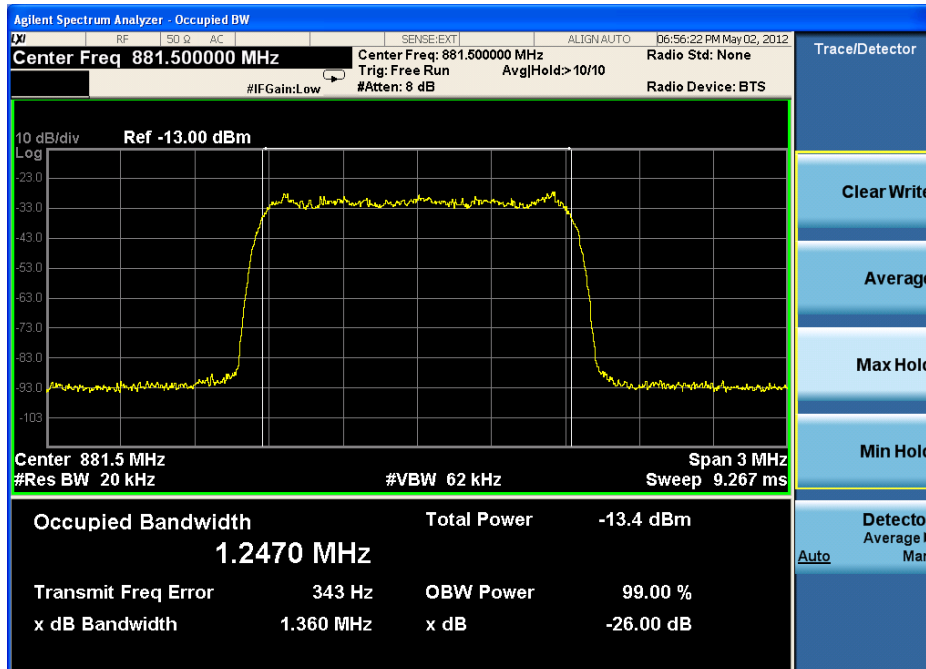

1.4 Downlink:869MHz to 894MHz (middle frequency)-- Output

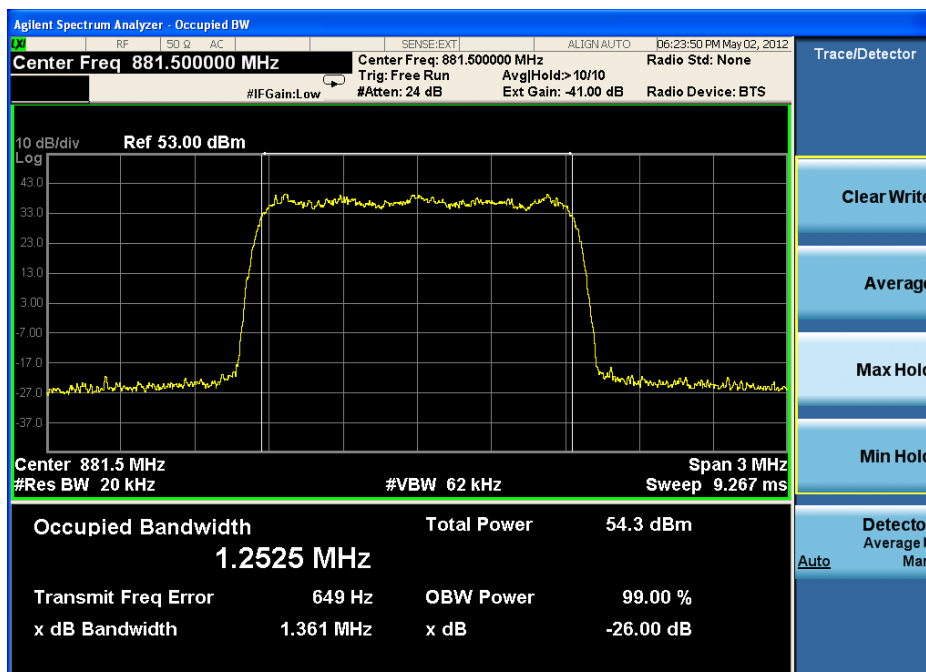



1.5 Downlink:869MHz to 894MHz (highest frequency)—Input

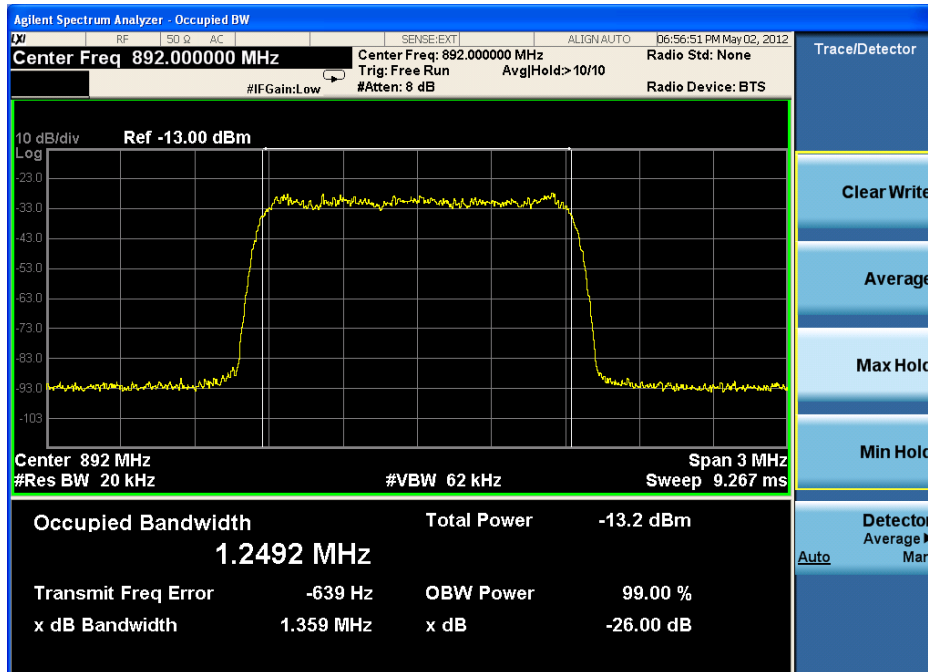

1.6 Downlink:869MHz to 894MHz (highest frequency)--Output

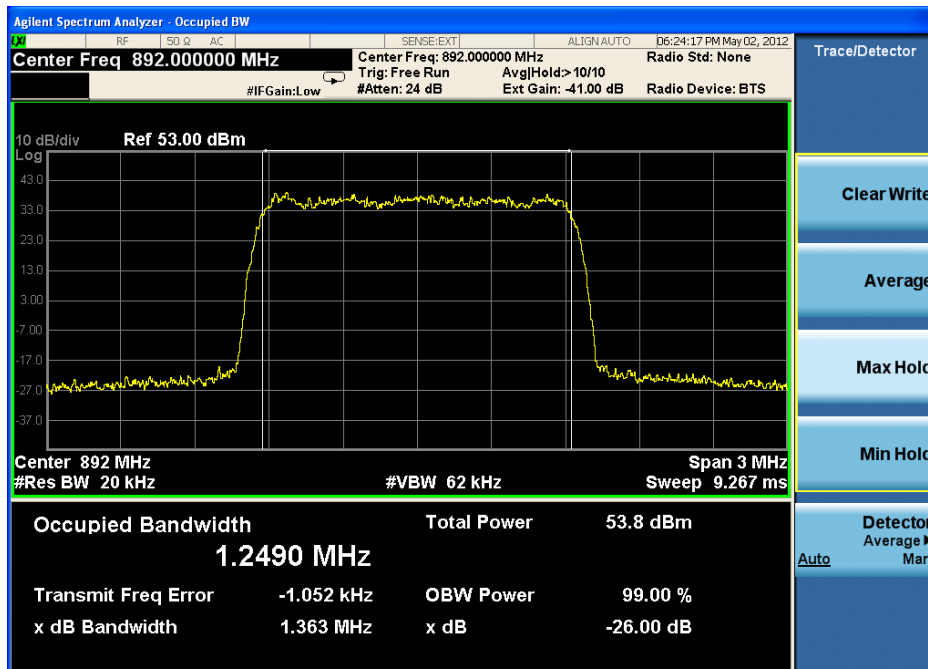



2. Test for WCDMA:

2.1 Downlink:869MHz to 894MHz (lowest frequency) -- Input

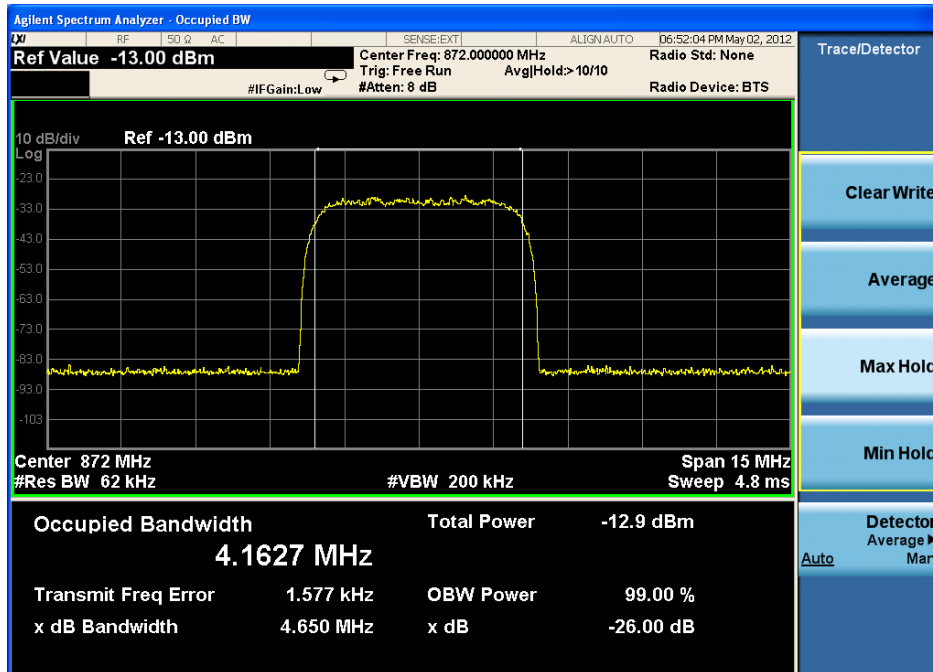

2.2 Downlink:869MHz to 894MHz (lowest frequency)-- Output

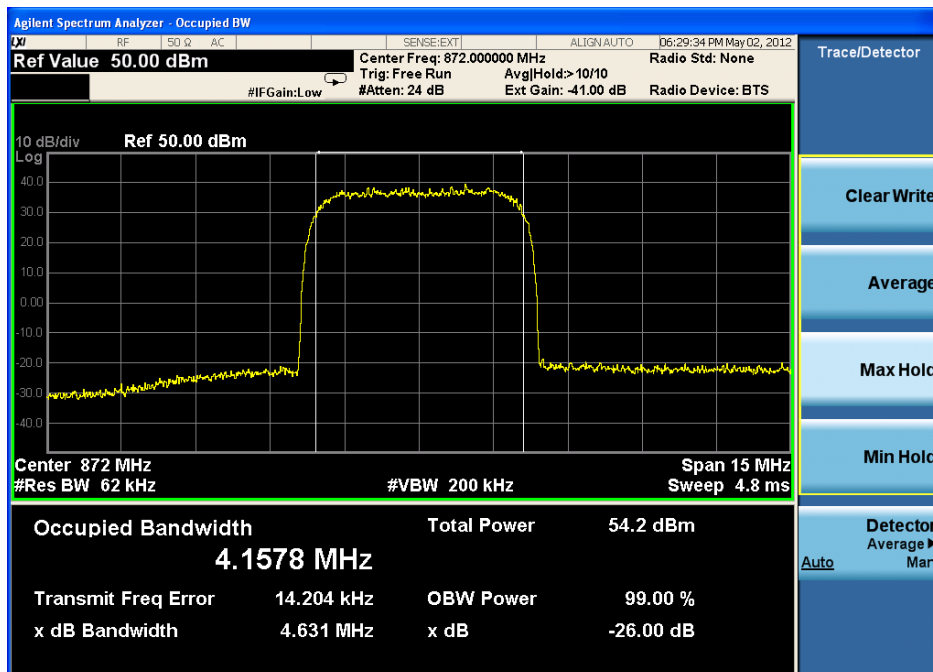



2.3 Downlink:869MHz to 894MHz (middle frequency)-- Input

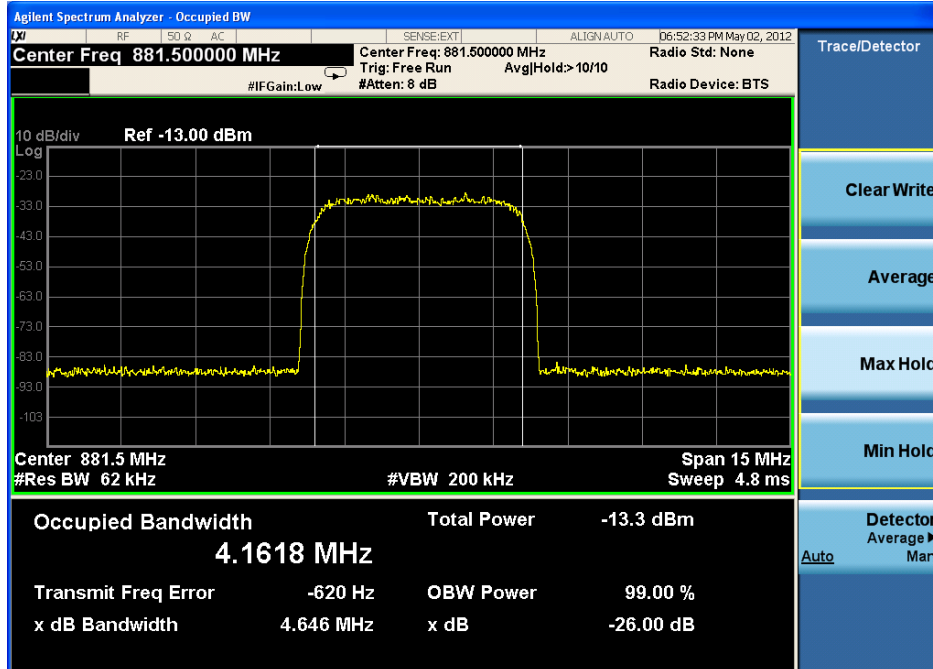

2.4 Downlink:869MHz to 894MHz (middle frequency)-- Output

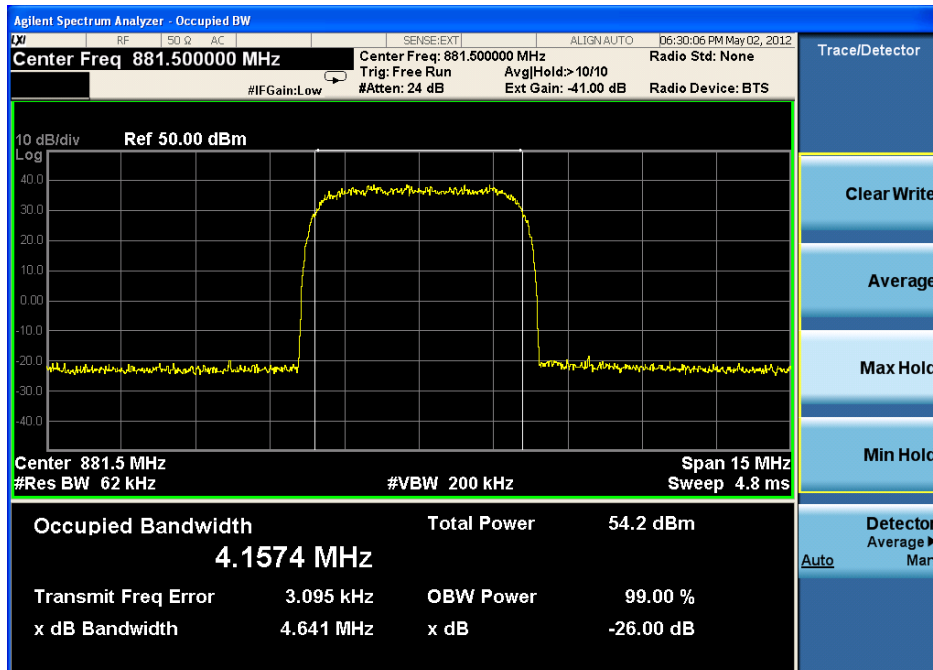



2.5 Downlink:869MHz to 894MHz (highest frequency)—Input

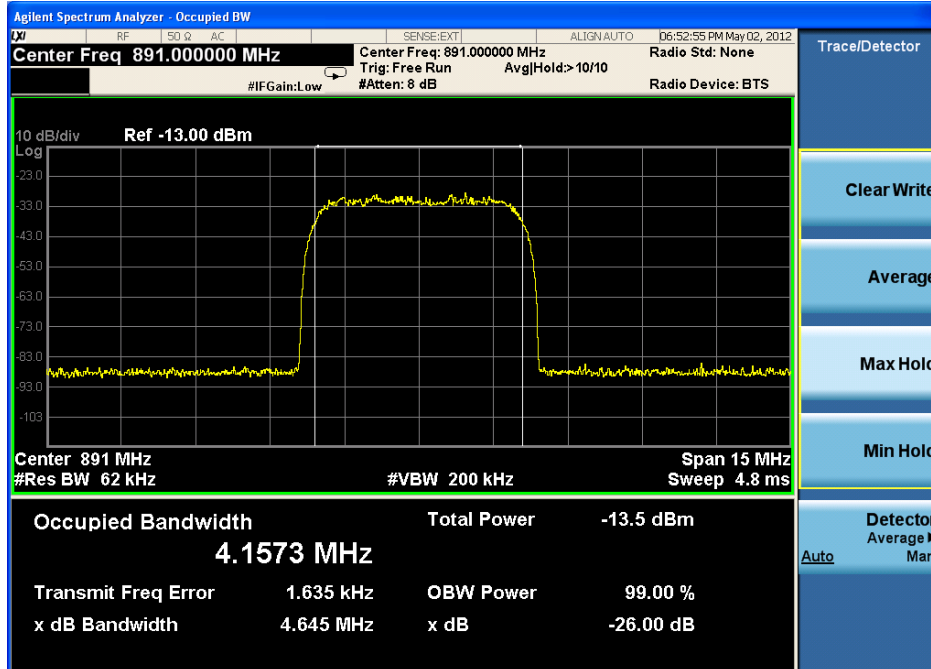

2.6 Downlink:869MHz to 894MHz (highest frequency)--Output

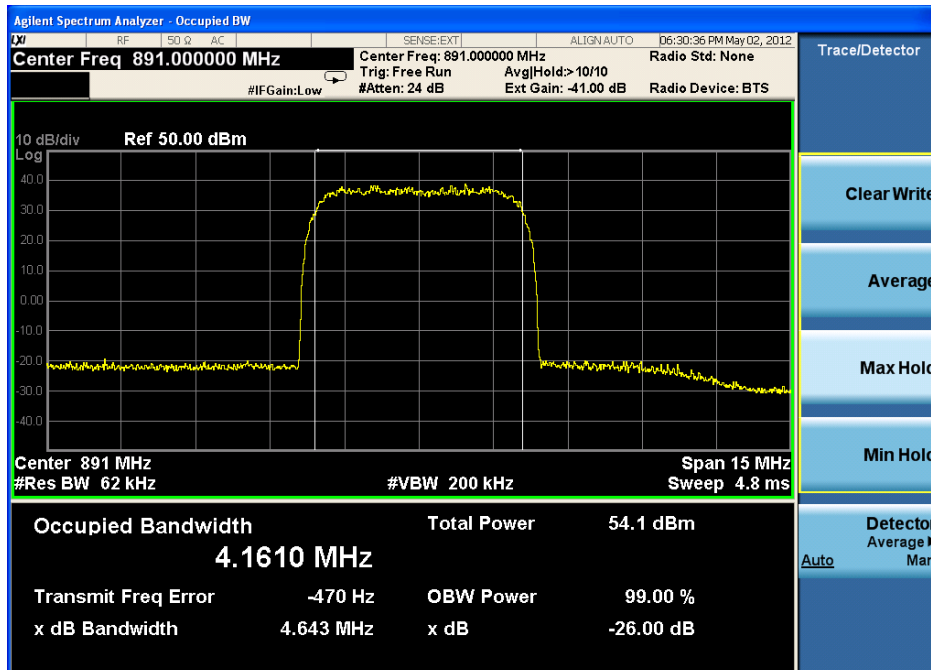



2.7 Downlink:2110MHz to 2155MHz (lowest frequency) -- Input

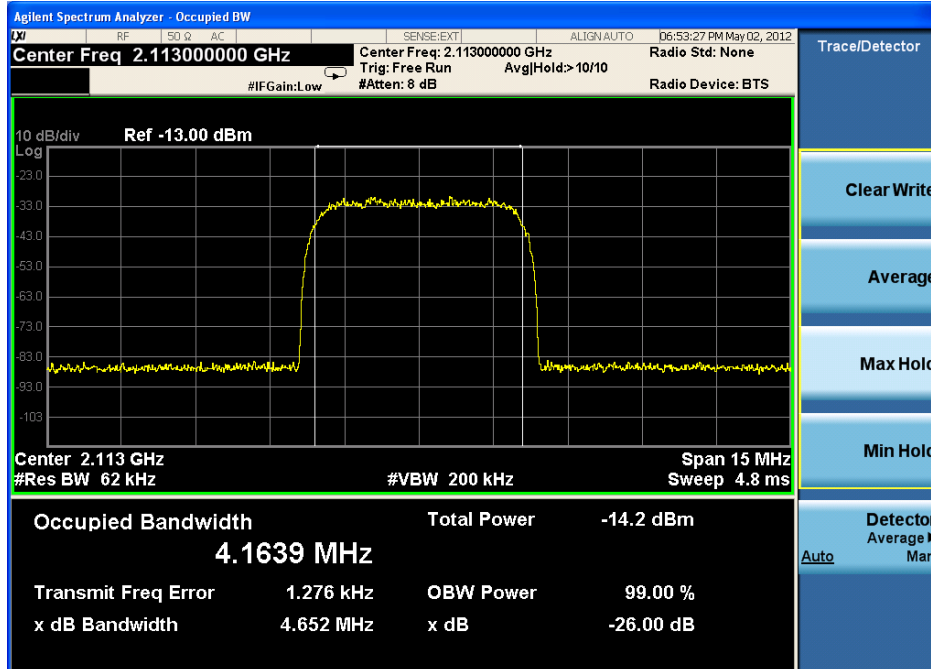

2.8 Downlink: 2110MHz to 2155MHz (lowest frequency)-- Output

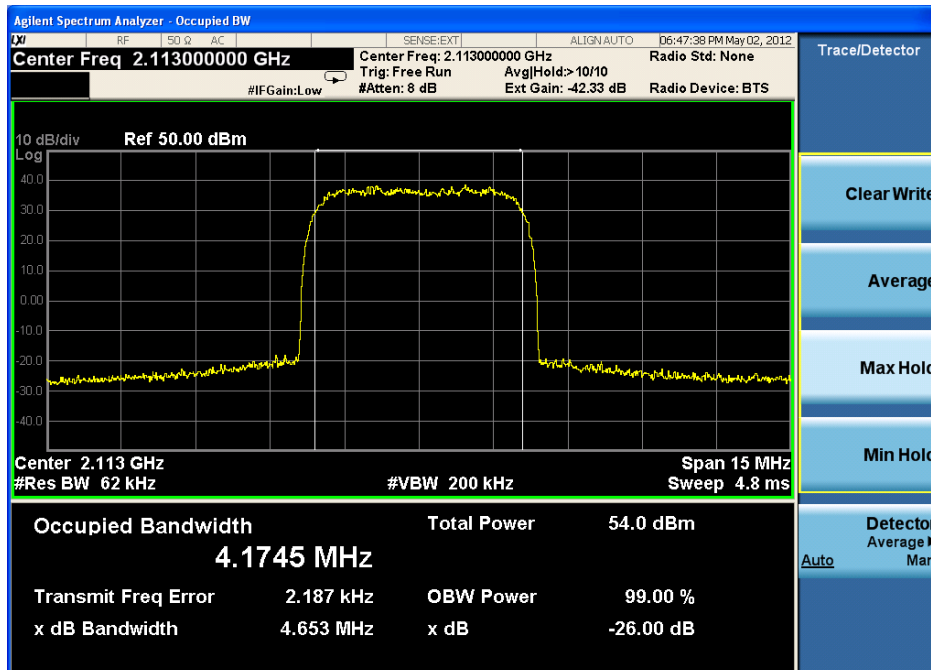



2.9 Downlink: 2110MHz to 2155MHz (middle frequency)-- Input

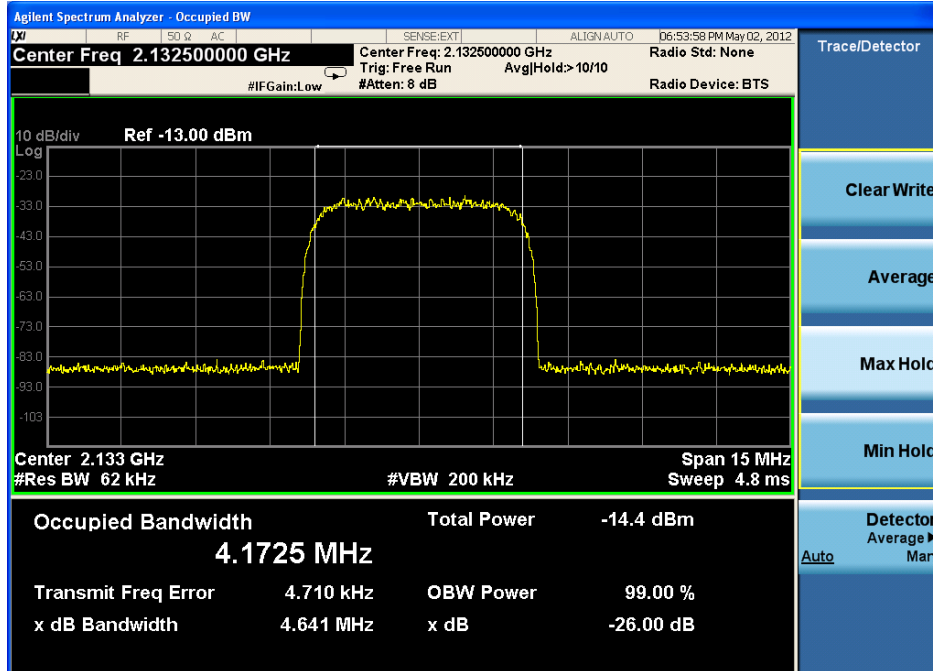

2.10 Downlink: 2110MHz to 2155MHz (middle frequency)-- Output

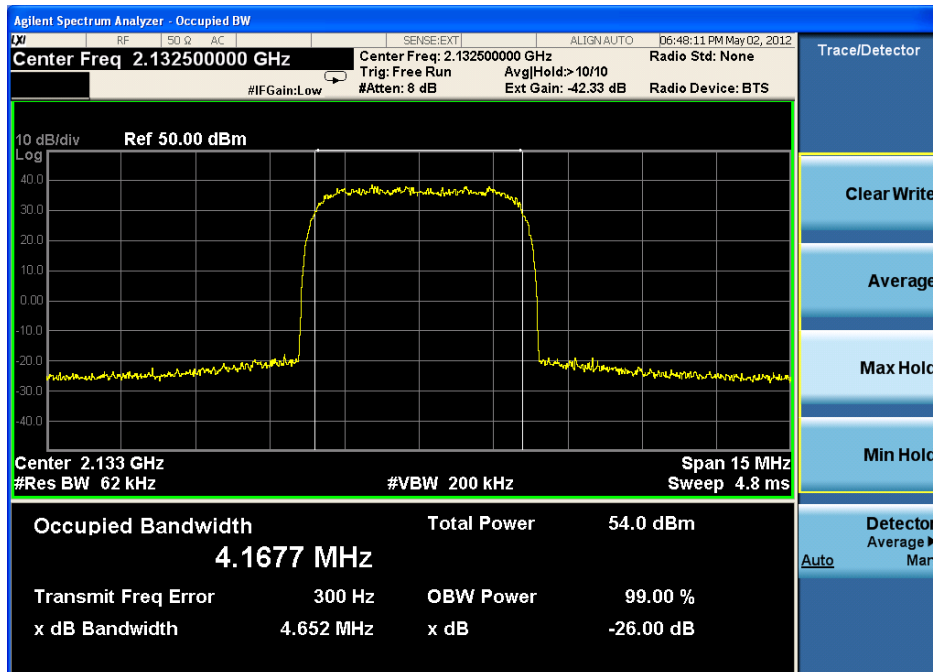





2.11 Downlink: 2110MHz to 2155MHz (highest frequency)—Input

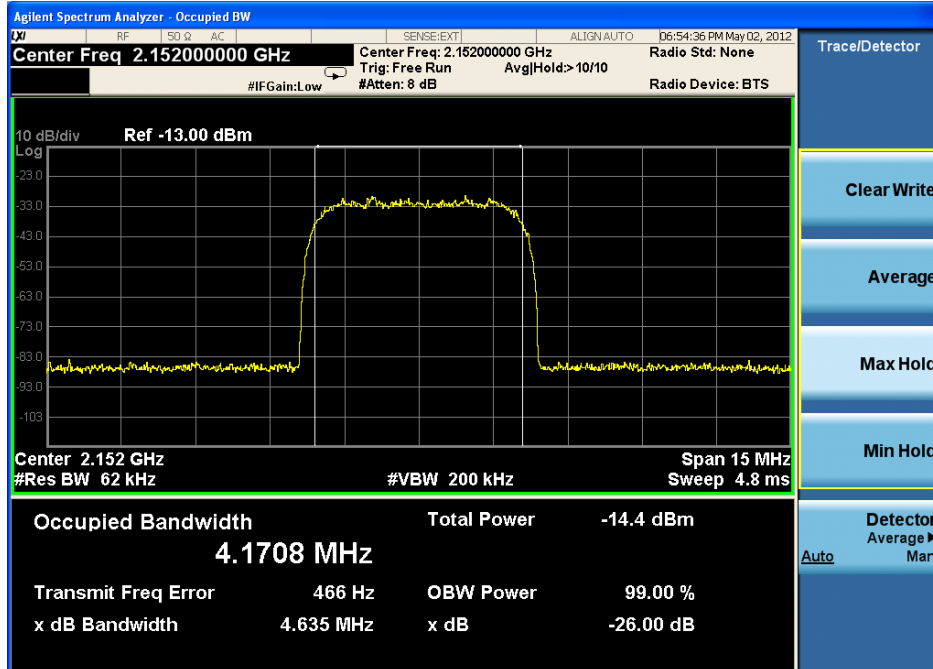

2.12 Downlink: 2110MHz to 2155MHz (highest frequency)--Output

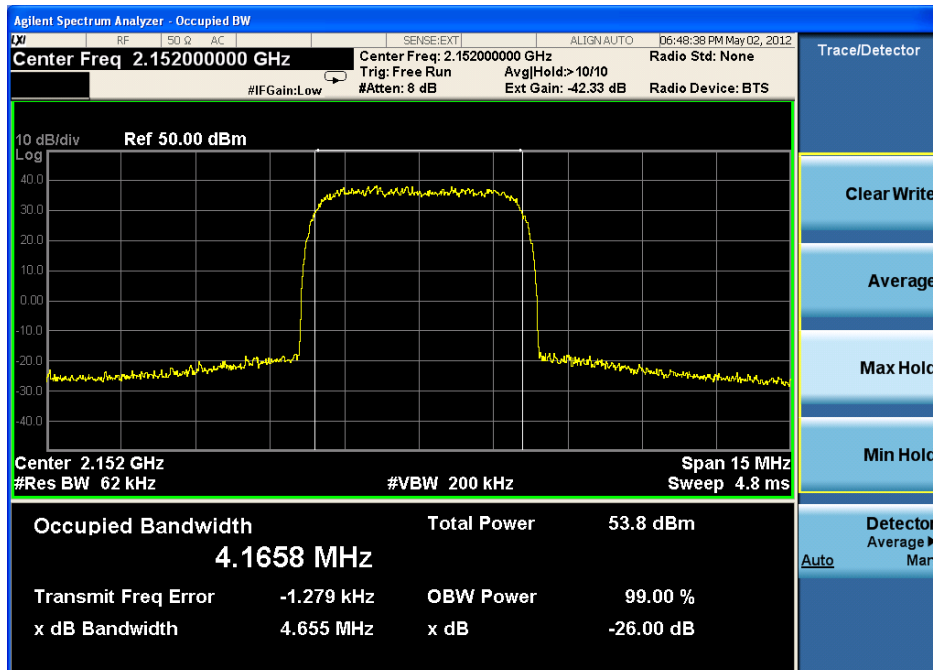



### 3.Test for GSM:

#### 3.1 Downlink:869MHz to 894MHz (lowest frequency) -- Input

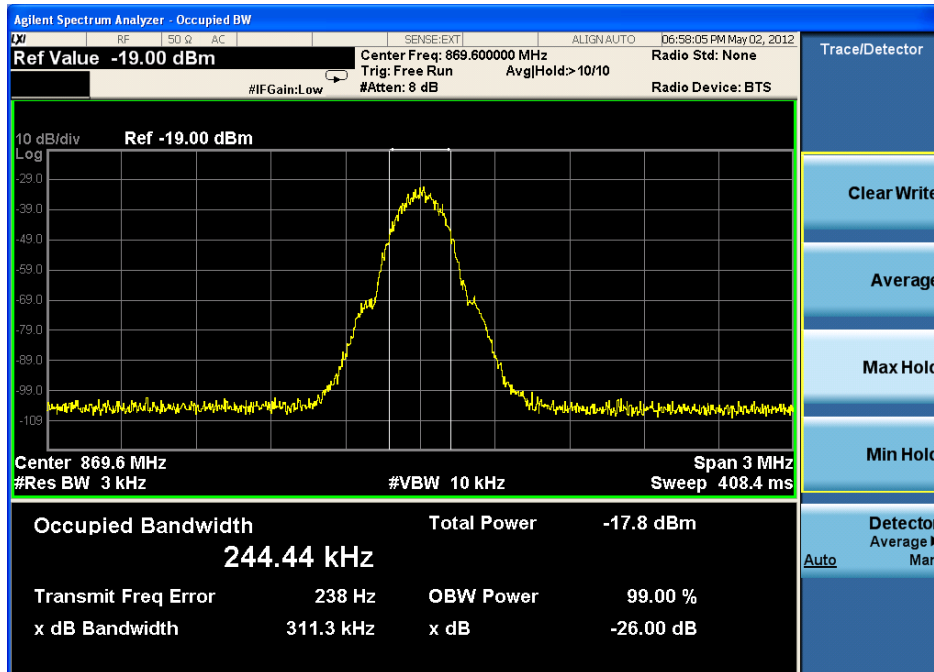

#### 3.2 Downlink:869MHz to 894MHz (lowest frequency)-- Output

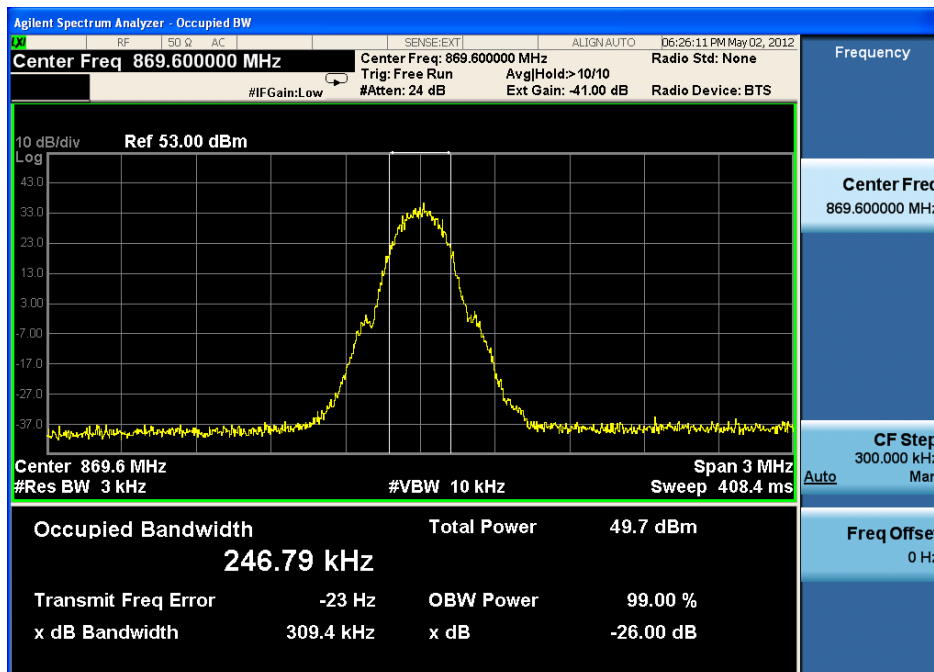



3.3 Downlink:869MHz to 894MHz (middle frequency)-- Input

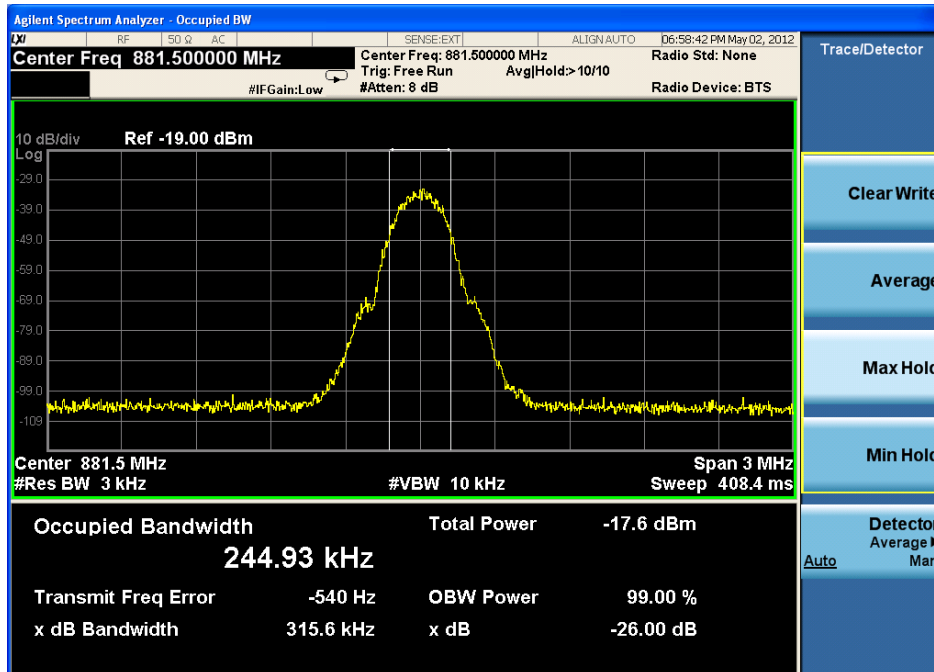

3.4 Downlink:869MHz to 894MHz (middle frequency)-- Output

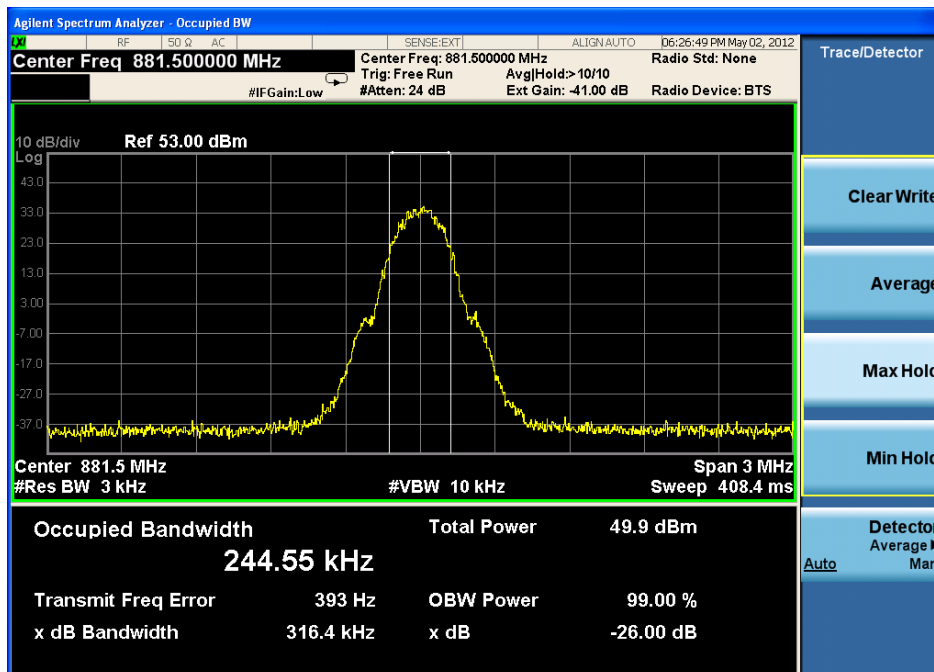



3.5 Downlink:869MHz to 894MHz (highest frequency)—Input

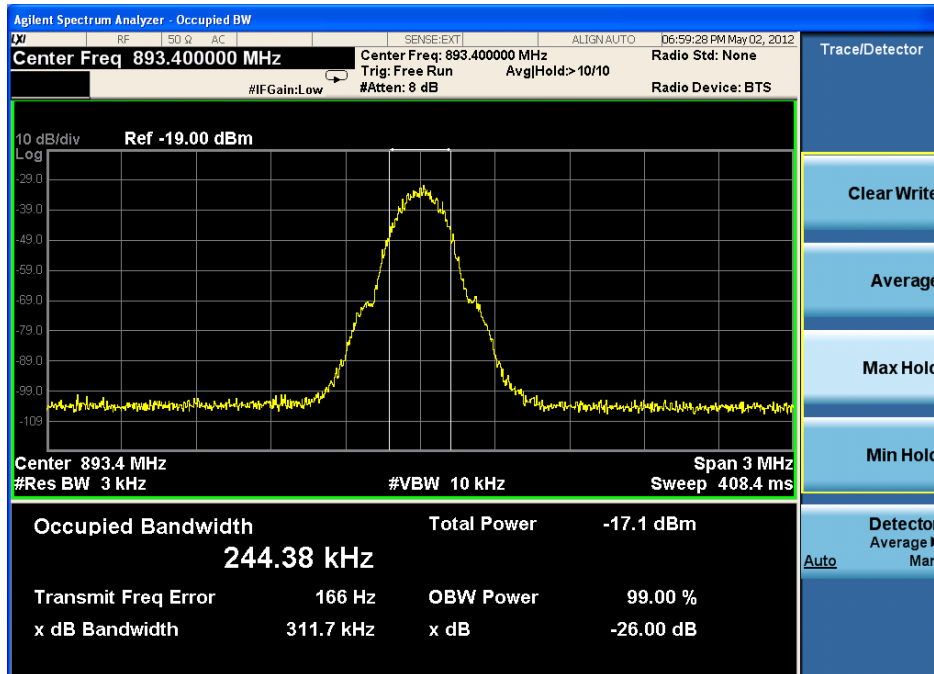

3.6 Downlink:869MHz to 894MHz (highest frequency)--Output

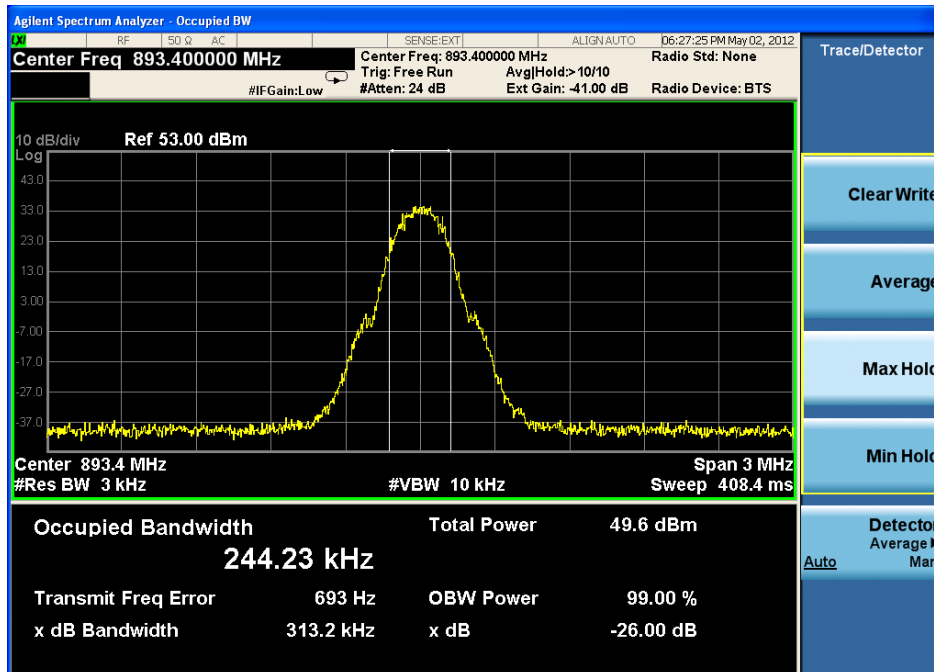



4. Test for LTE:

4.1 Downlink: 728MHz to 757MHz (lowest frequency) -- Input

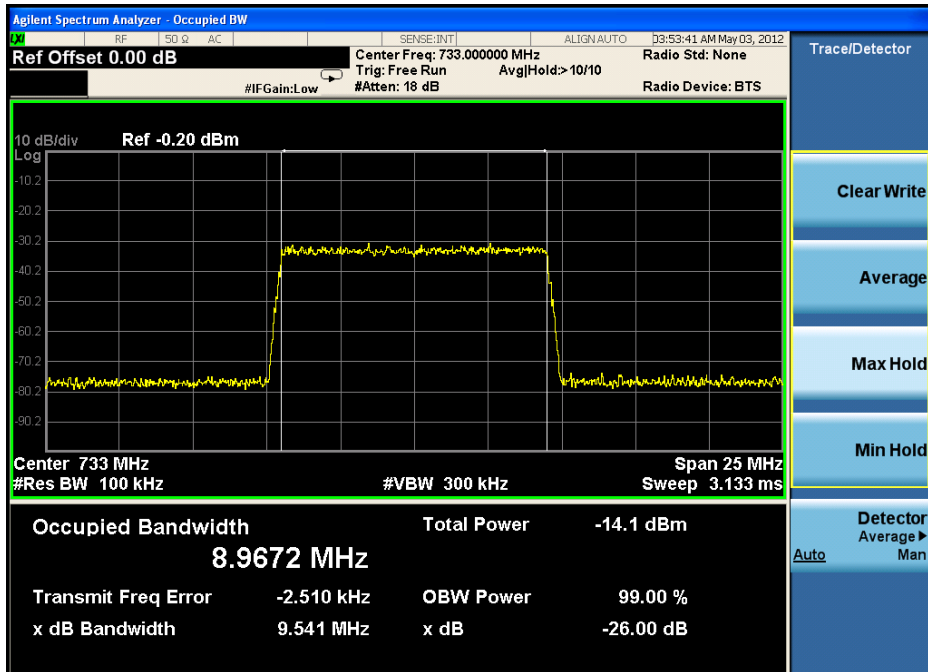

4.2 Downlink: 728MHz to 757MHz (lowest frequency)-- Output

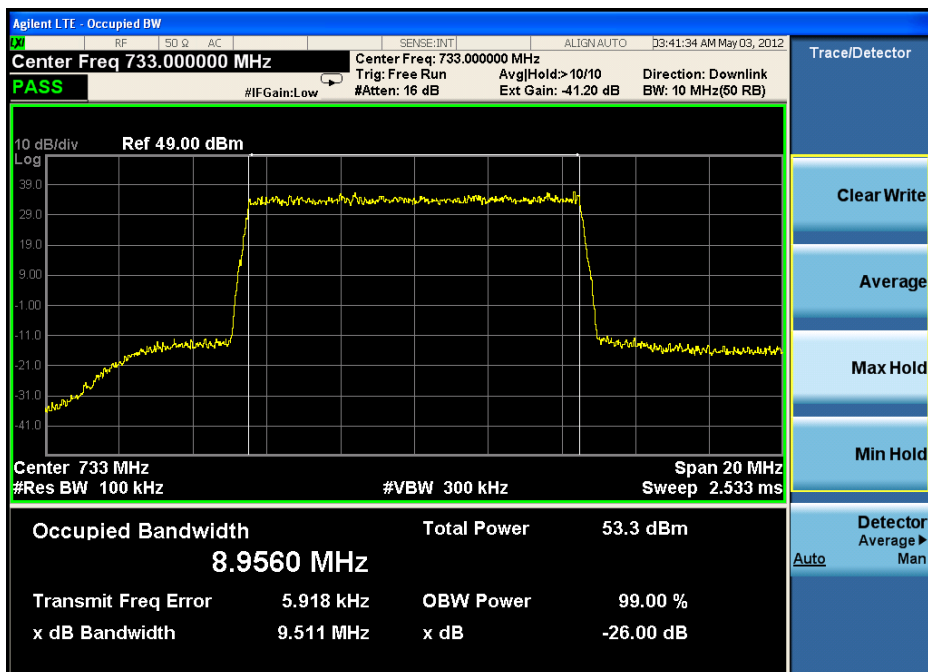



4.3 Downlink: 728MHz to 757MHz (middle frequency)-- Input

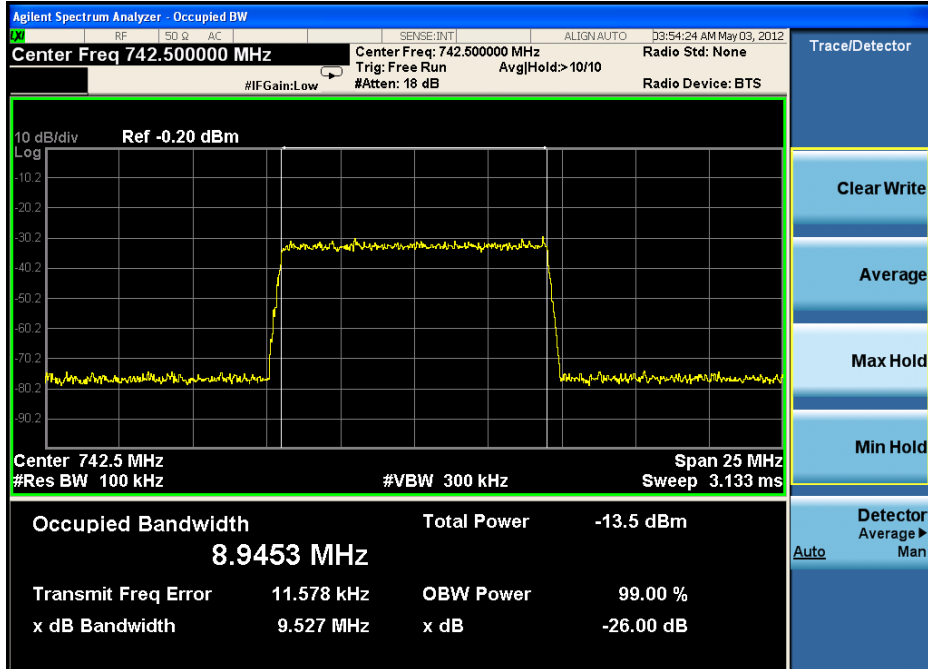

4.4 Downlink: 728MHz to 757MHz (middle frequency)-- Output

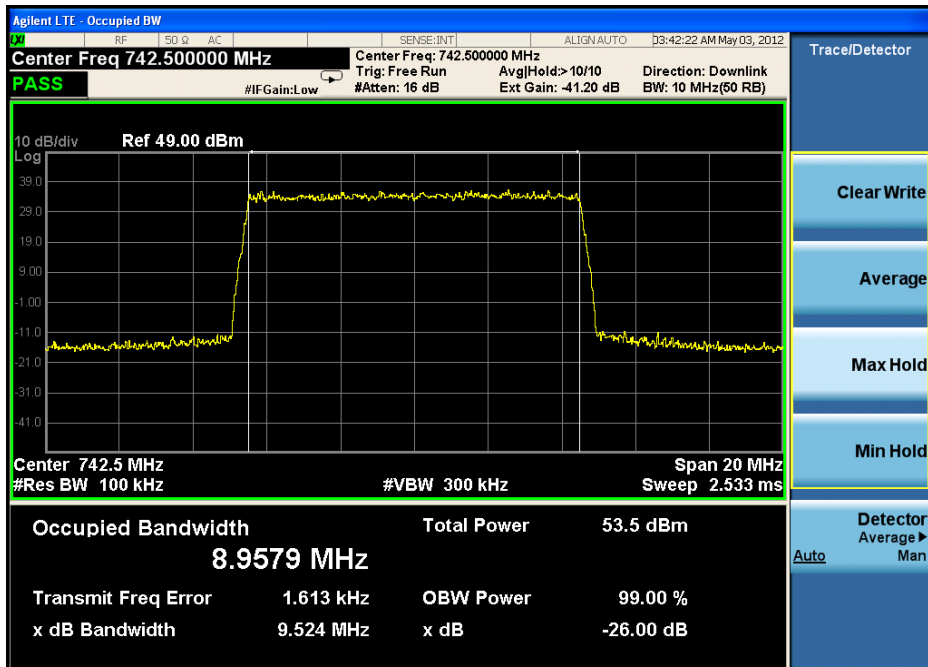



4.5 Downlink: 728MHz to 757MHz (highest frequency)—Input

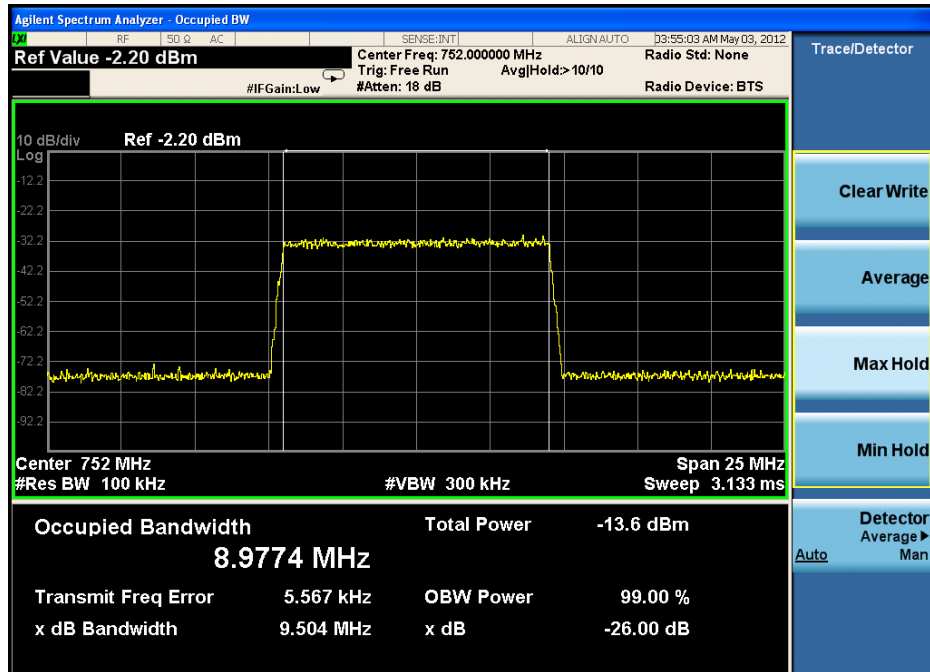

4.6 Downlink: 728MHz to 757MHz (highest frequency)--Output

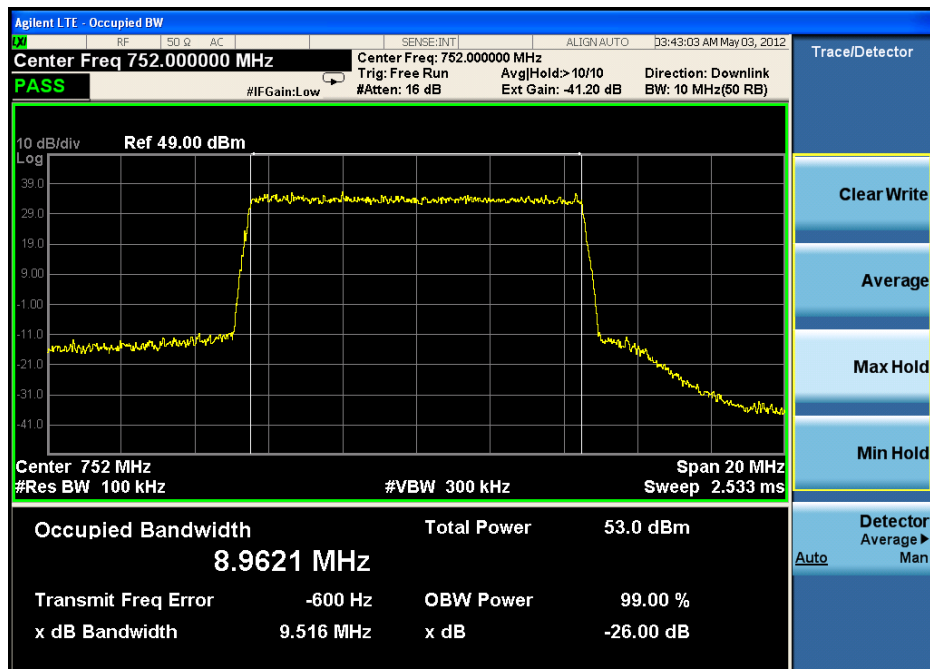



4.7 Downlink:869MHz to 894MHz (lowest frequency) -- Input

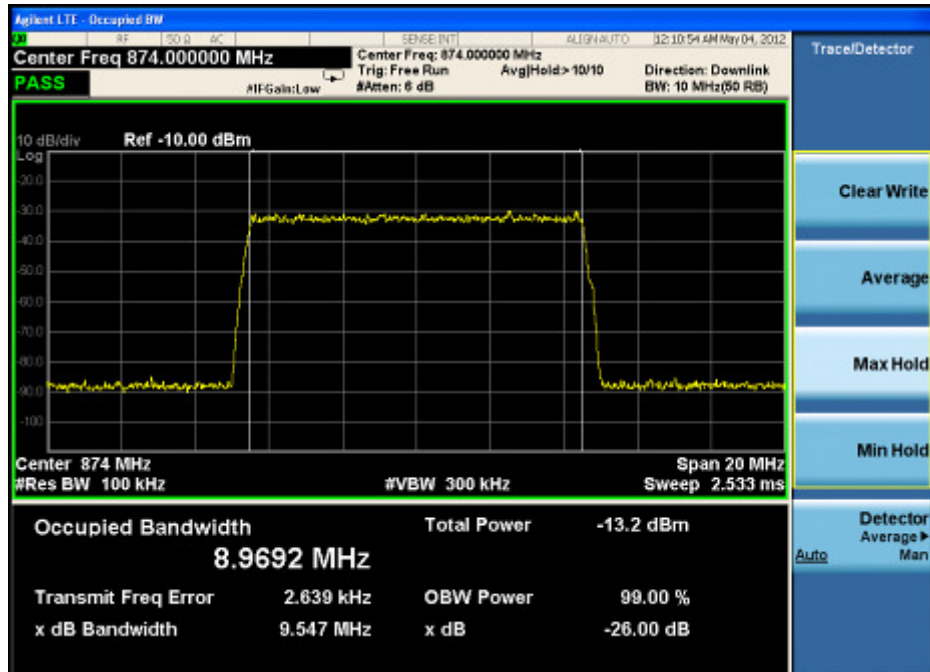

4.8 Downlink: 869MHz to 894MHz (lowest frequency)-- Output

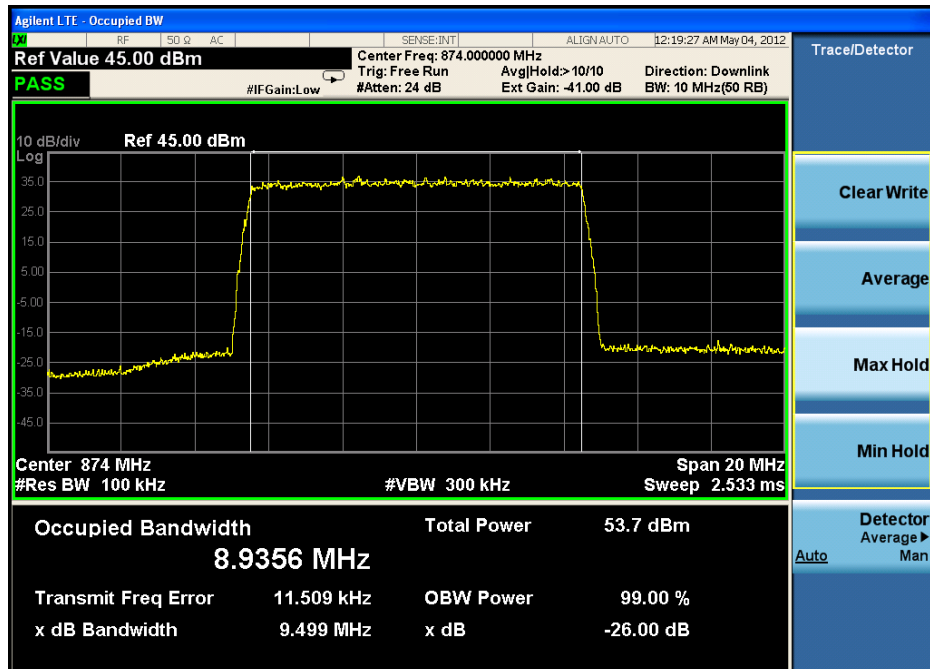





4.9 Downlink: 869MHz to 894MHz (middle frequency)-- Input

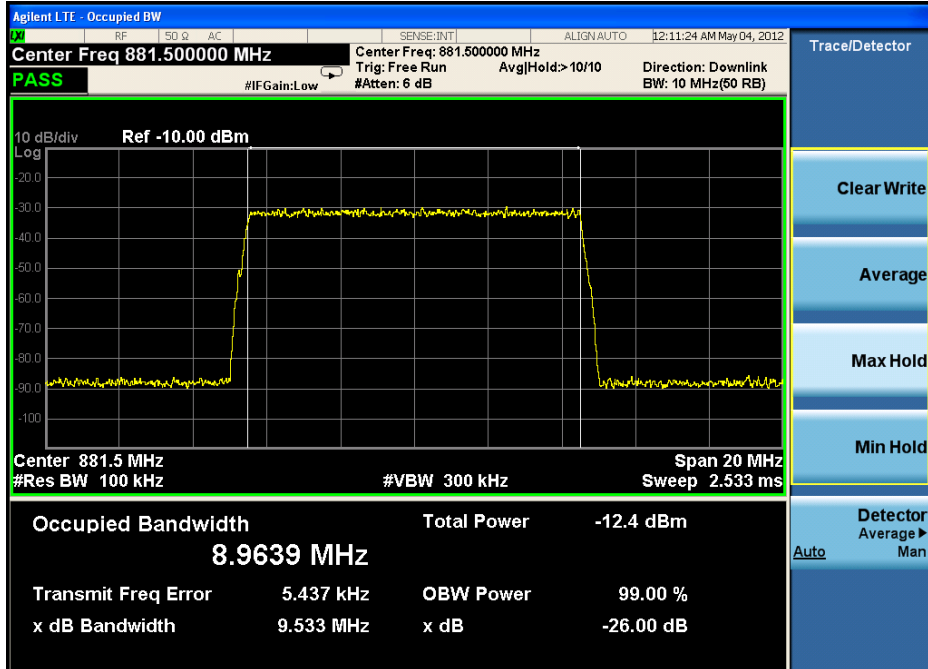

4.10 Downlink: 869MHz to 894MHz (middle frequency)-- Output

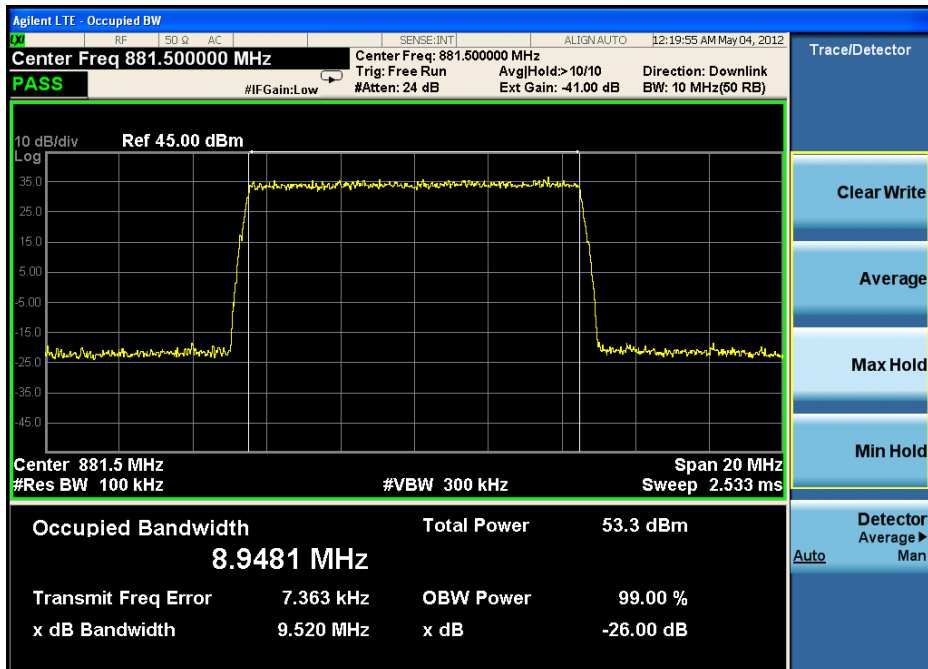



4.11 Downlink: 869MHz to 894MHz (highest frequency)—Input

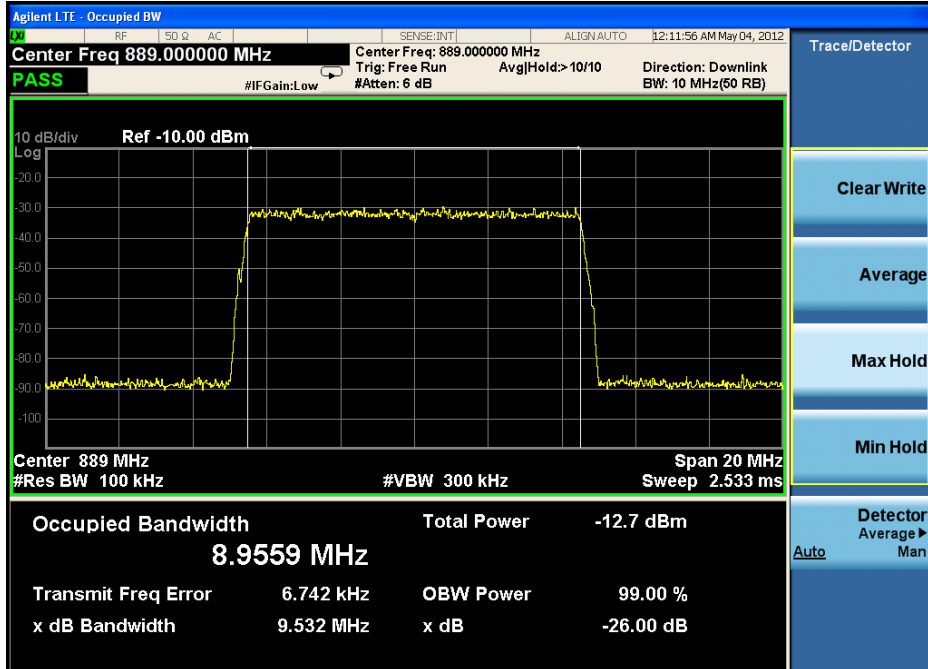

4.12 Downlink: 869MHz to 894MHz (highest frequency)--Output

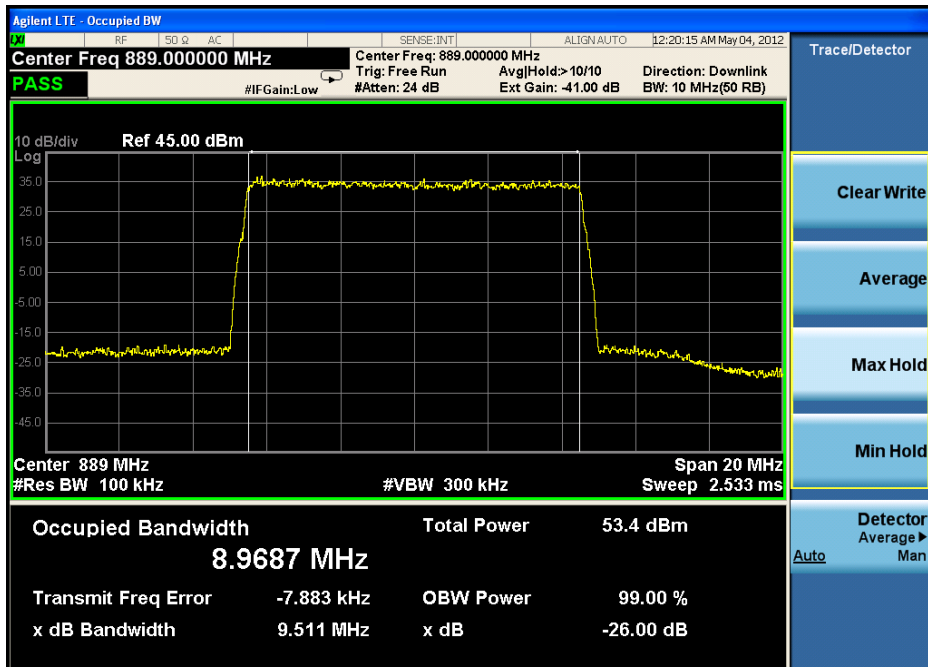



4.13 Downlink:2110MHz to 2155MHz (lowest frequency) -- Input

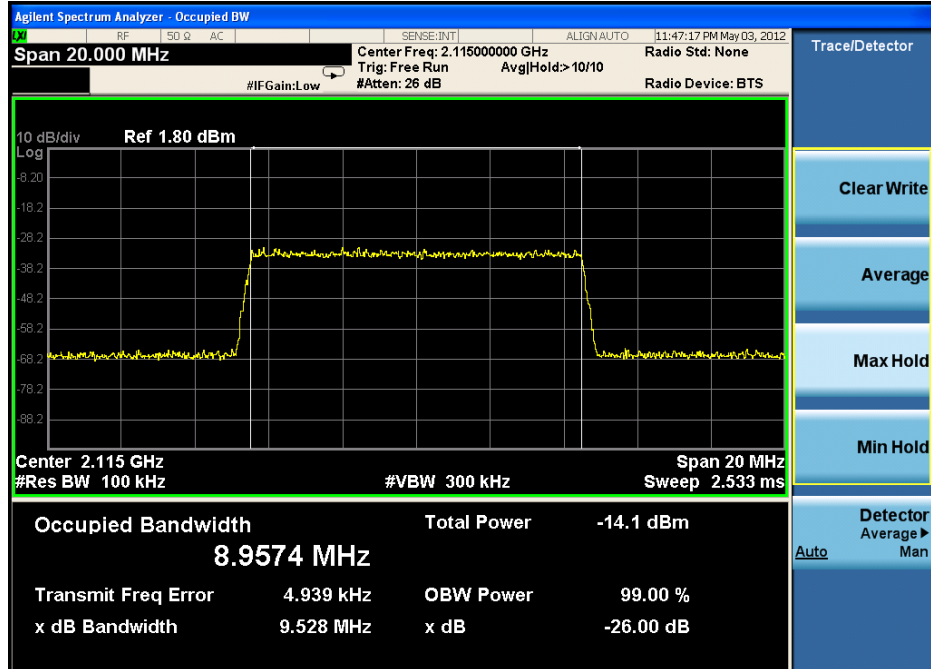

4.14 Downlink: 2110MHz to 2155MHz (lowest frequency)-- Output

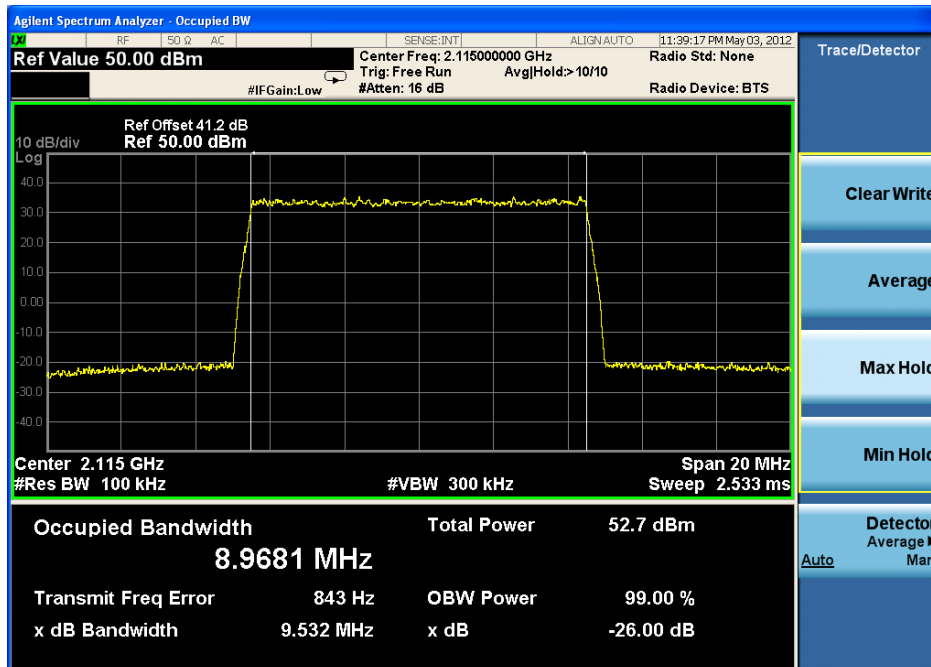



4.15 Downlink: 2110MHz to 2155MHz (middle frequency)-- Input

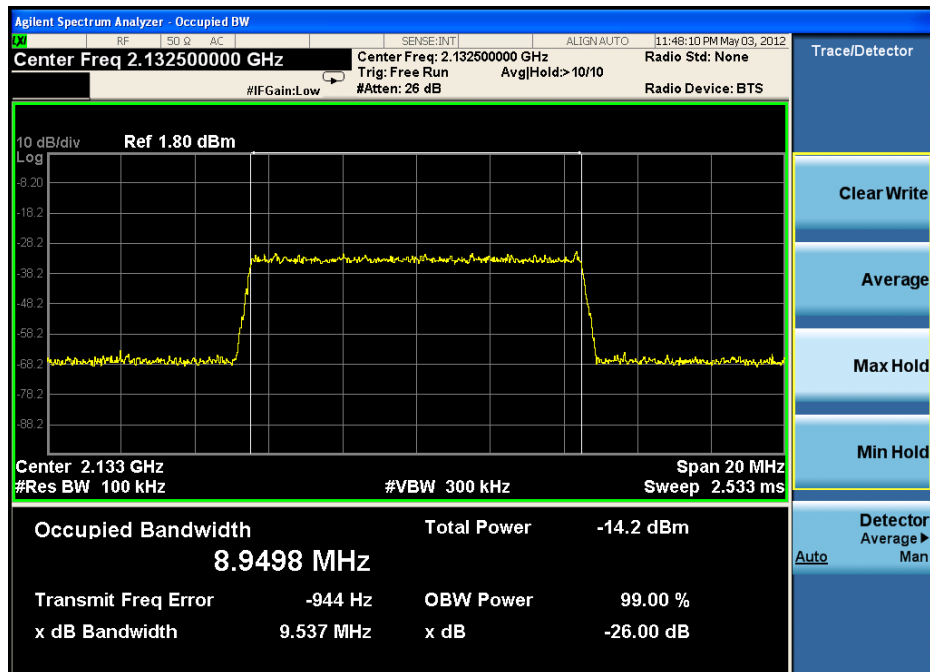

4.16 Downlink: 2110MHz to 2155MHz (middle frequency)-- Output

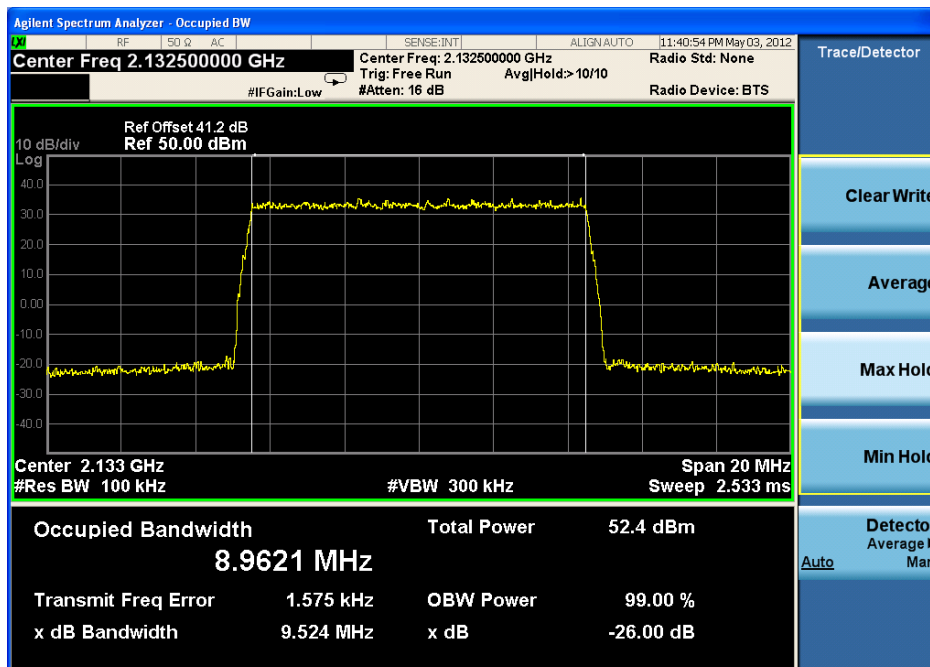



4.17 Downlink: 2110MHz to 2155MHz (highest frequency)—Input

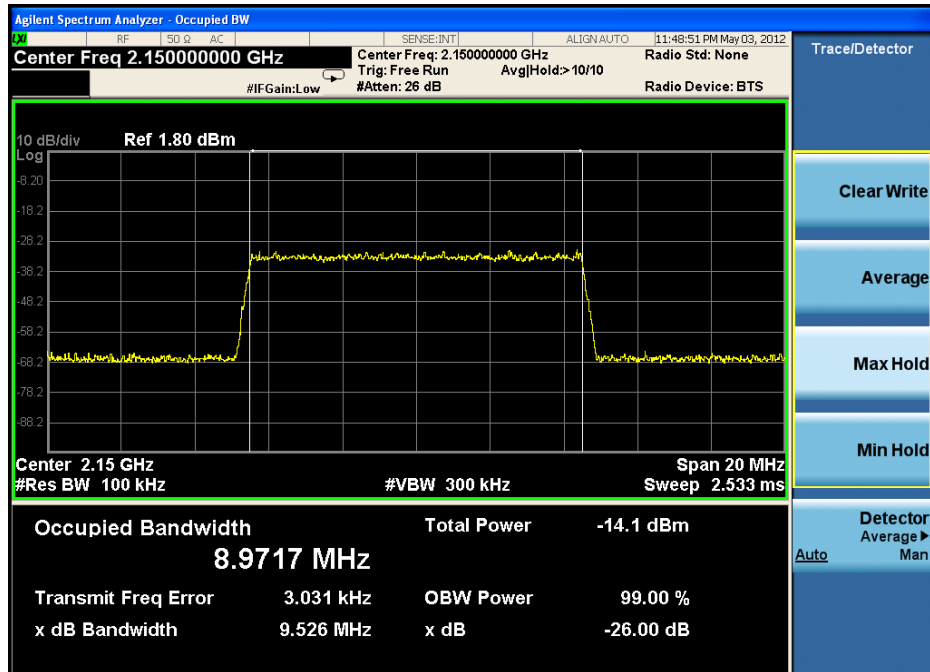

4.18 Downlink: 2110MHz to 2155MHz (highest frequency)--Output

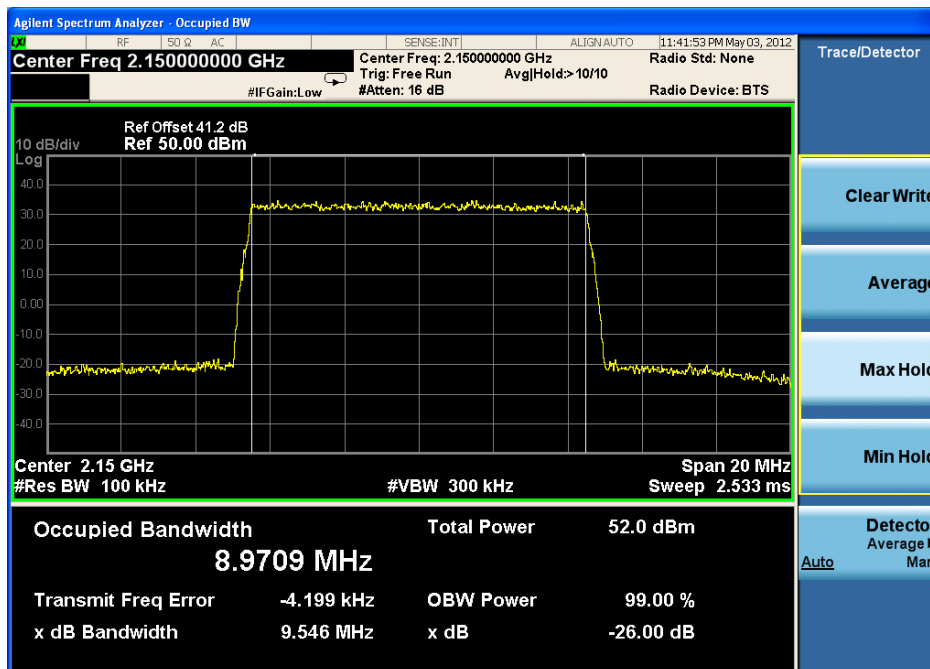

### 7.2.6 Out of Band Rejection

Test Date: 2012-05-02  
 Test Requirement: 2-11-04/EAB/RF  
 Test for rejection of out of band signals. Filter freq. response plots are acceptable.  
 Test Method: 2-11-04/EAB/RF  
 EUT Operation:  
 Status: Drive the EUT to maximum output power. .  
 Conditions: Normal conditions  
 Application: Cellular Band RF output ports  
 Test Configuration:

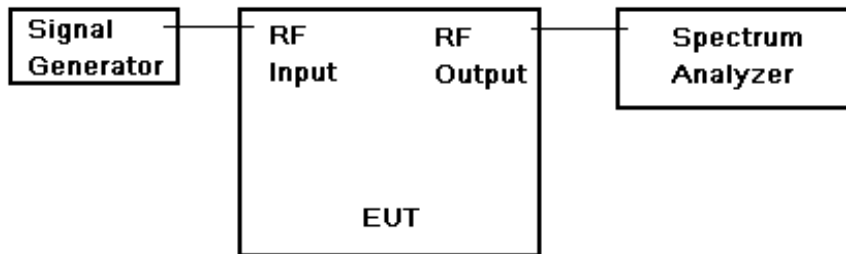

Fig.4. Out of Band rejection test configuration

- Test Procedure:
1. Connect the equipment as illustrated;
  2. Test the background noise level with all the test facilities;
  3. Keep one transmitting path, all other connectors shall be connected by normal power or RF leads;
  4. Select the attenuator to avoid the test receiver or spectrum analyzer being destroyed;
  5. Keep the EUT continuously transmitting in max power;
  6. Signal generator sweep from the frequency more lower than the product frequency to the frequency more higher than it, find the product band filter characteristic;
- CW signal rather than typical signal is acceptable (for FM).
  - Multiple band filter will need test each other.



7.2.6.1 Measurement Record:

1.Test for Downlink:869MHz to 894MHz

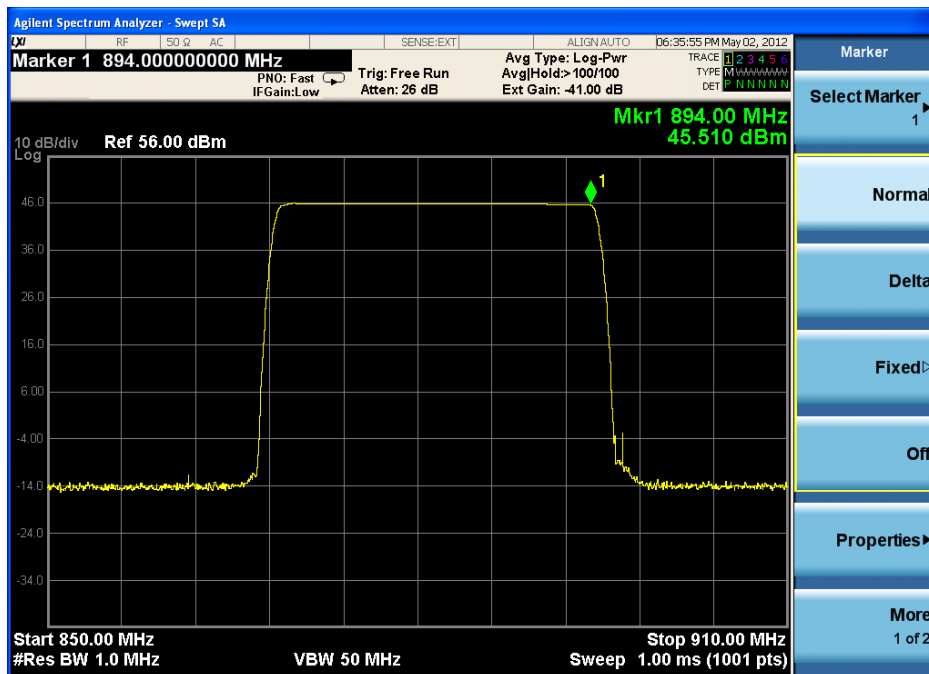
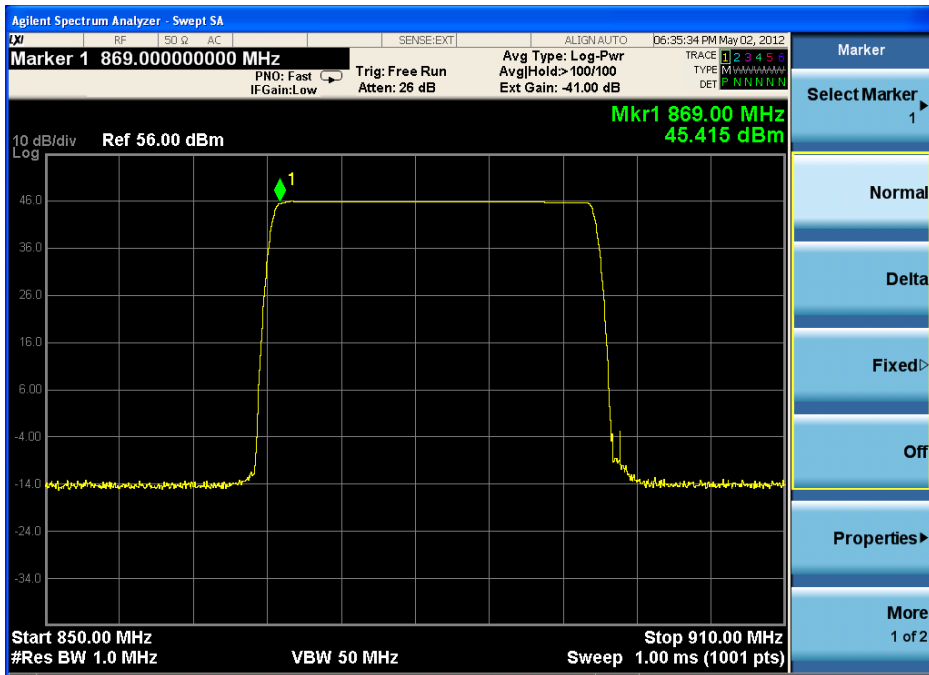



2. Test for Downlink:728MHz to 757MHz

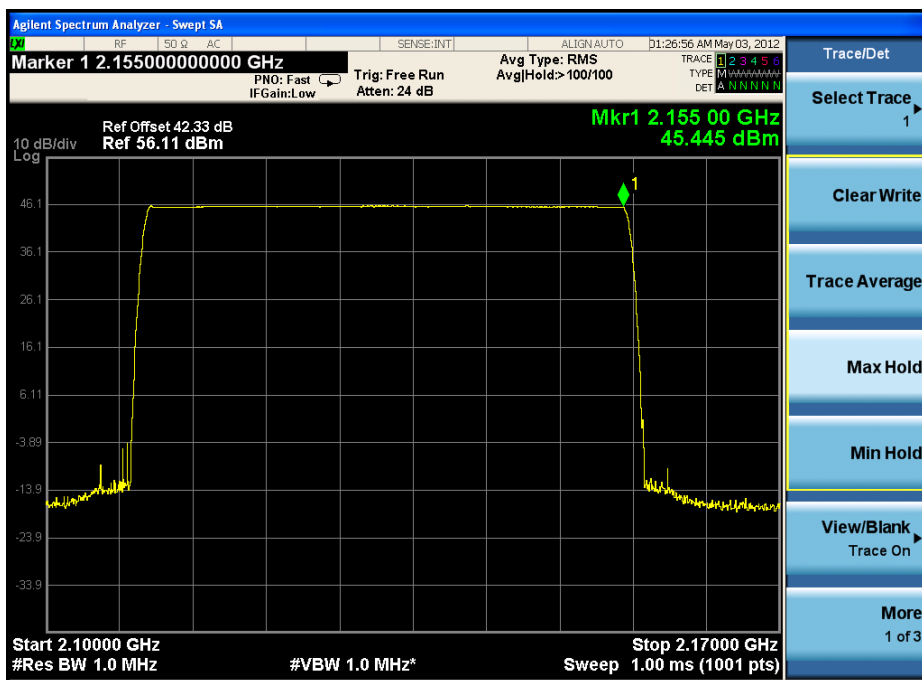
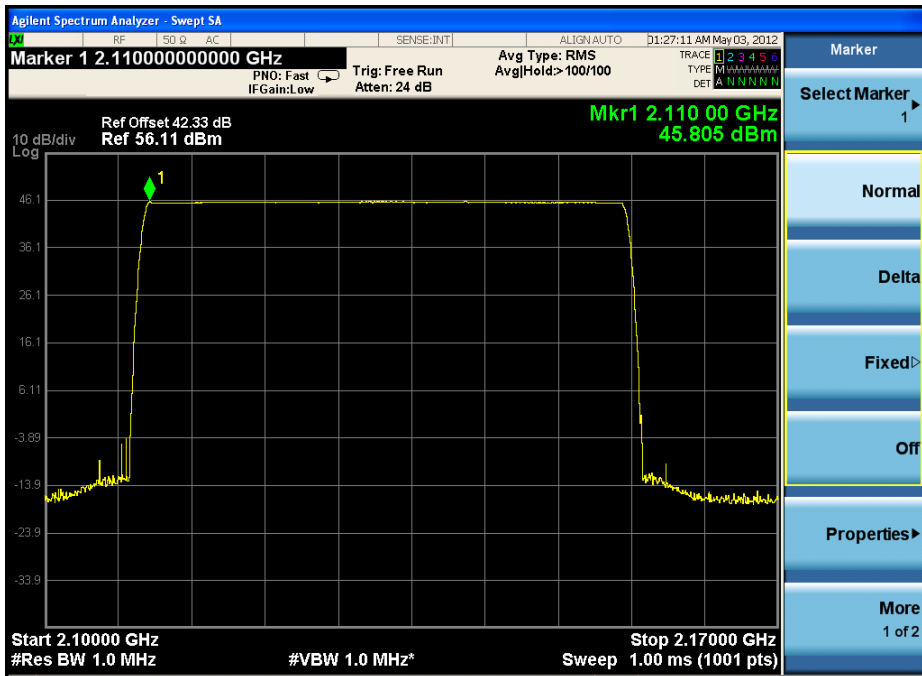





3. Test for Downlink:2110MHz to 2155MHz

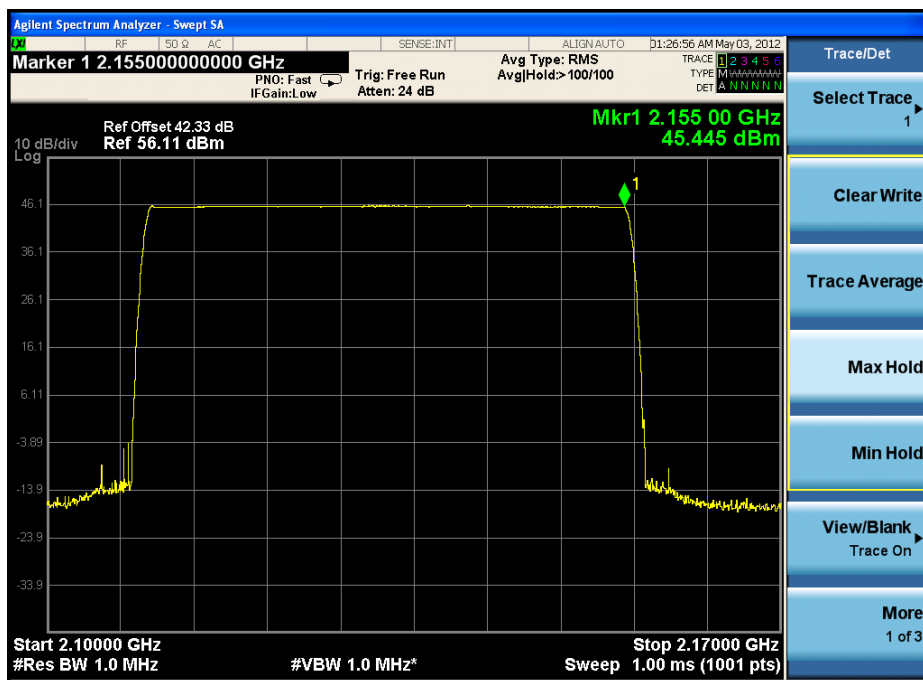



### 7.2.7 Frequency Stability

Test Date: 2012-05-04

Test Requirement: FCC part 22.355 & FCC part 27.54

The frequency stability shall be sufficient to ensure that the fundamental emissions stay within the authorized bands of operation.

Test Method: FCC part 2.1055

EUT Operation:

Status: Drive the EUT to maximum output power.

Conditions: Temperature conditions, voltage conditions

Application: Cellular Band RF output ports

Test Procedure:

1. Temperature conditions:

- a) The RF output port of the EUT was connected to Frequency Meter;
- b) Set the working Frequency in the middle channel;
- c) record the 20°C and nominal voltage frequency value as reference point;
- d) vary the temperature from -40°C to 50°C with step 10°C
- e) when reach a temperature point, keep the temperature balance at least 1 hour to make the product working in this status;
- f) read the frequency at the relative temperature.

2. Voltage conditions:

- a) record the 20°C and nominal voltage frequency value as reference point;
- b) vary the voltage from -15% nominal voltage to +15% voltage;
- c) read the frequency at the relative voltage.



7.2.7.1 Measurement Record:

Frequency Stability vs temperature:

1.Test for Downlink: 728~757MHz (middle channel 742.5MHz)

Temperature(°C)	Frequency(MHz)	Tolerance(ppm)
50	742.5000032	0.001481
40	742.5000031	0.001347
30	742.5000033	0.001617
20	742.5000021	Reference
10	742.5000034	0.001751
0	742.5000030	0.001212
-10	742.5000035	0.001886
-20	742.5000033	0.001617
-30	742.5000032	0.001481
-40	742.5000031	0.001347

2.Test for Downlink: 869~894MHz (middle channel 881.5MHz)

Temperature(°C)	Frequency(MHz)	Tolerance(ppm)
50	881.5000047	0.001475
40	881.5000046	0.001361
30	881.5000046	0.001361
20	881.5000034	Reference
10	881.5000045	0.001248
0	881.5000044	0.001134
-10	881.5000048	0.001592
-20	881.5000047	0.001476
-30	881.5000052	0.002042
-40	881.5000039	0.000567

3.Test for Downlink: 2110~2155MHz (middle channel 2132.5MHz)

Temperature(°C)	Frequency(MHz)	Tolerance(ppm)
50	2132.5000053	0.000281
40	2132.5000051	0.000188
30	2132.5000049	0.000094
20	2132.5000047	Reference
10	2132.5000052	0.000234
0	2132.5000055	0.000375
-10	2132.5000051	0.000188
-20	2132.5000053	0.000281
-30	2132.5000049	0.000093
-40	2132.5000048	0.000047



Frequency Stability vs voltage:

**4. Test for Downlink: 728~757MHz (middle channel 742.5MHz)**

Voltage(V AC)	Frequency(MHz)	Tolerance(ppm)
102 (120*0.85)	742.5000032	0.001481
120	742.5000021	Reference
138 (120*1.15)	742.5000028	0.000942

**5. Test for Downlink: 869~894MHz (middle channel 881.5MHz)**

Voltage(V AC)	Frequency(MHz)	Tolerance(ppm)
102 (120*0.85)	881.5000043	0.001021
120	881.5000034	Reference
138 (120*1.15)	881.5000046	0.001361

**6. Test for Downlink: 2110~2155MHz (middle channel 2132.5MHz)**

Voltage(V AC)	Frequency(MHz)	Tolerance(ppm)
102 (120*0.85)	2132.5000054	0.000328
120	2132.5000047	Reference
138 (120*1.15)	2132.5000052	0.000234

**--The End of Report--**