



ERMO 482X3 PRO

External Microwave Protection
Barrier
Installation Handbook

Edition 1.2

INDEX

1	DESCRIPTION	2
1.1	DESCRIPTION	2
1.2	BLOCK DIAGRAM	3
2	INSTALLATION	4
2.1	PRELIMINARY INFORMATION	4
2.2	NUMBER OF SECTIONS	4
2.3	GROUND CONDITIONS	5
2.4	PRESENCE OF OBSTACLES	5
2.5	AMPLITUDE OF THE SENSITIVE BEAM	6
2.6	LENGTH OF THE DEAD ZONES NEAR THE EQUIPMENT	8
2.7	HOW TO CALCULATE THE SIZE OF THE BEAM AND DEAD ZONES	9
2.8	MICROWAVE WORKING PLANE	10
2.9	WALL INSTALLATION	13
3	CONNECTIONS	14
3.1	TERMINAL BLOCKS, CONNECTORS AND CIRCUITS FUNCTIONS	14
3.1.1	<i>Transmitter Circuit</i>	14
3.1.2	<i>Receiver Circuit</i>	17
3.2	EQUIPMENT CONNECTION TO THE POWER SUPPLY	20
3.2.1	<i>Connection to the Power Supply</i>	20
3.2.2	<i>Connection of stand-by Battery</i>	20
3.3	CONNECTION TO THE CONTROL PANEL	21
3.3.1	<i>Alarm contacts: Alarm, Tamper, Fault</i>	21
3.3.2	<i>Synchronism connection</i>	22
3.3.3	<i>Stand-by connection</i>	22
3.3.4	<i>Test connection</i>	22
3.3.5	<i>Balanced Line connection</i>	22
3.4	SERIAL LINE RS-485	24
3.4.1	<i>RS - 485 / 232 / USB Network Connection Interface</i>	24
3.4.2	<i>RS -485 Serial Line connections</i>	24
3.4.3	<i>Network Configuration and Signal Repeaters</i>	24
4	ADJUSTMENT AND TESTING	26
4.1	ADJUSTMENT AND TESTING	26
4.1.1	<i>Transmitter Setting-up</i>	26
4.1.2	<i>Receiver Setting-up</i>	28
4.2	ADJUSTMENT AND TESTING WITH SOFTWARE	33
5	MAINTENANCE AND ASSISTANCE	34
5.1	TROUBLESHOOTING	34
5.2	MAINTENANCE KITS	34
6	CHARACTERISTICS	35
6.1	TECHNICAL CHARACTERISTICS	35
6.2	FUNCTIONAL CHARACTERISTICS	36
	TEST SHEET	0
	TEST SHEET	1

1 DESCRIPTION

1.1 Description

The ERMO 482X3 PRO equipment is a digital microwave barrier of CIAS, for internal and external volumetric protection. Such a system can detect the presence of somebody or something moving within the sensitive field present between a transmitter (Tx) and a receiver (Rx).

The received signal is processed in digital way and analysed with “Fuzzy” logic in order to obtain maximum performances and a minimum of false alarm rate.

The ERMO 482X3 PRO equipment is available with the following field range:

- ERMO 482X3 PRO 050 Range 50 meters
- ERMO 482X3 PRO 080 Range 80 meters
- ERMO 482X3 PRO 120 Range 120 meters
- ERMO 482X3 PRO 200 Range 200 meters
- ERMO 482X3 PRO 250 Range 250 meters
- ERMO 482X3 PRO 500 Range 500 meters

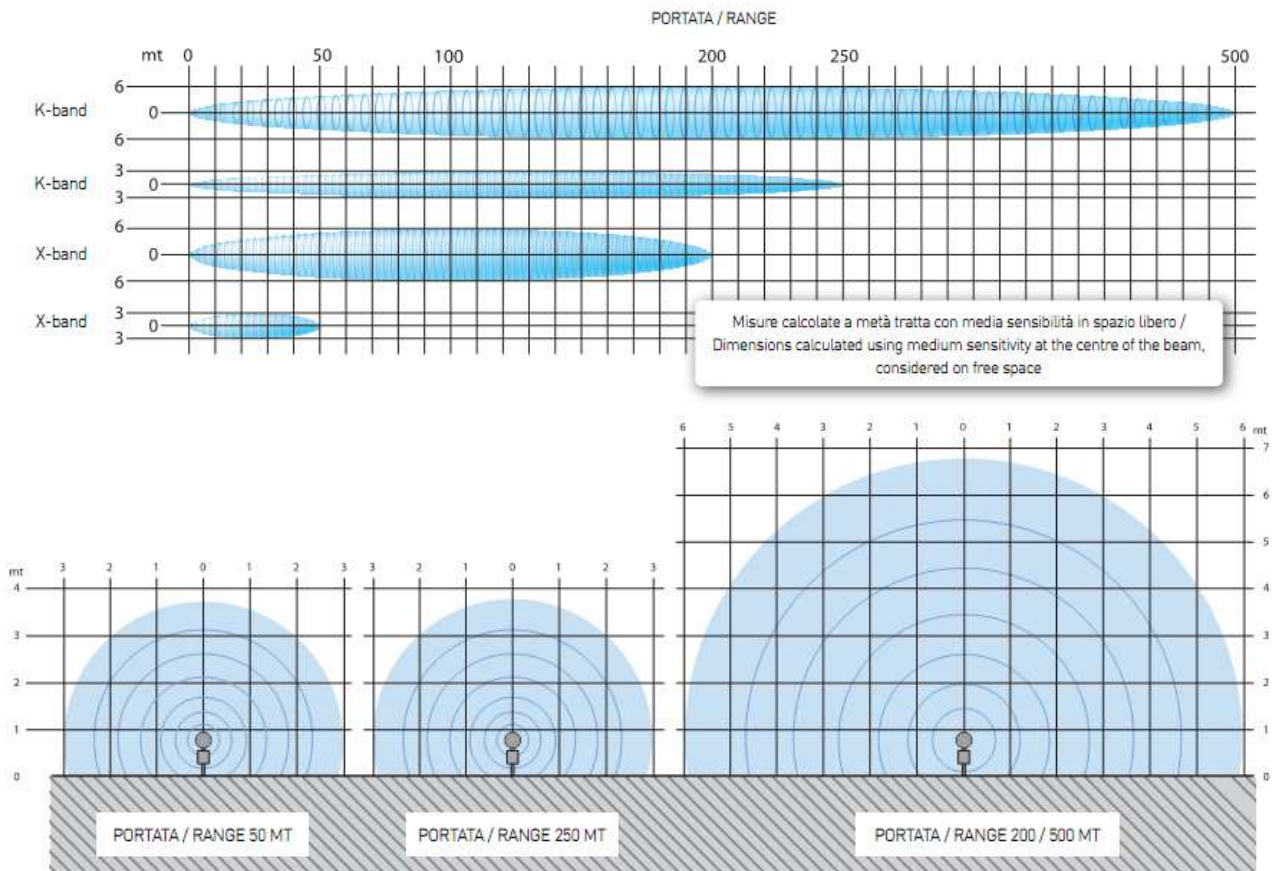

1.2 Block Diagram

In the following diagrams are showed the functional block of the complete ERMO 482X3 Pro (Transmitter and Receiver).

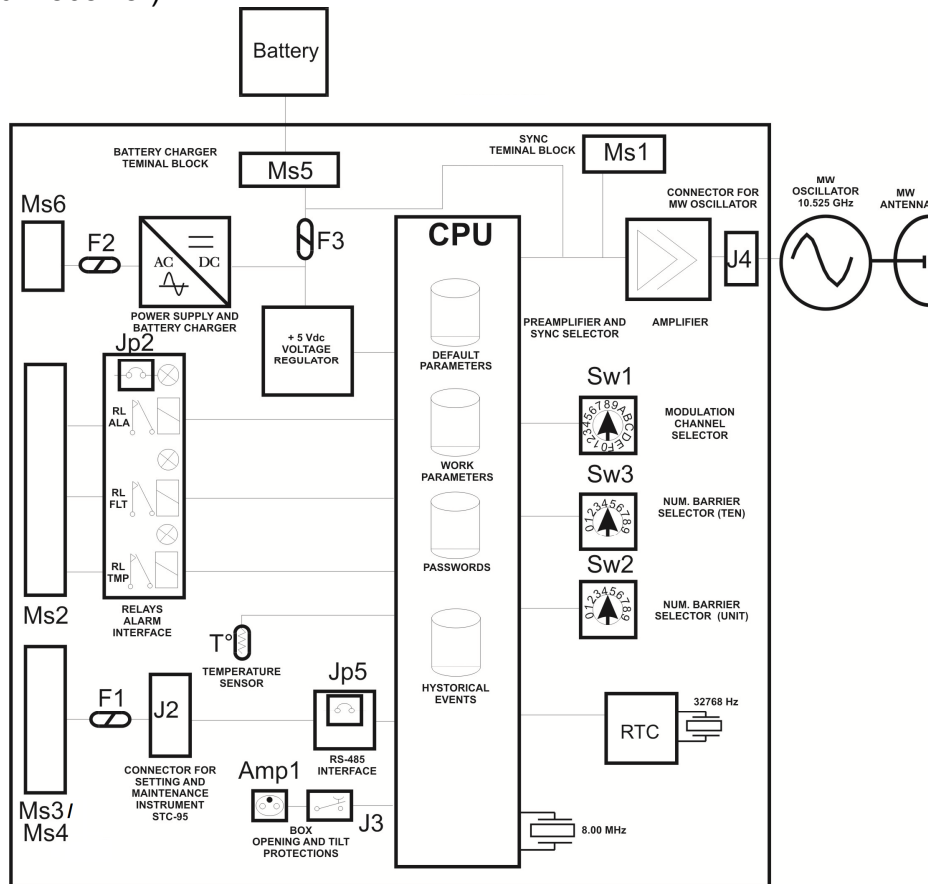

ERMO 482X3 PRO Transmitter Block Diagram

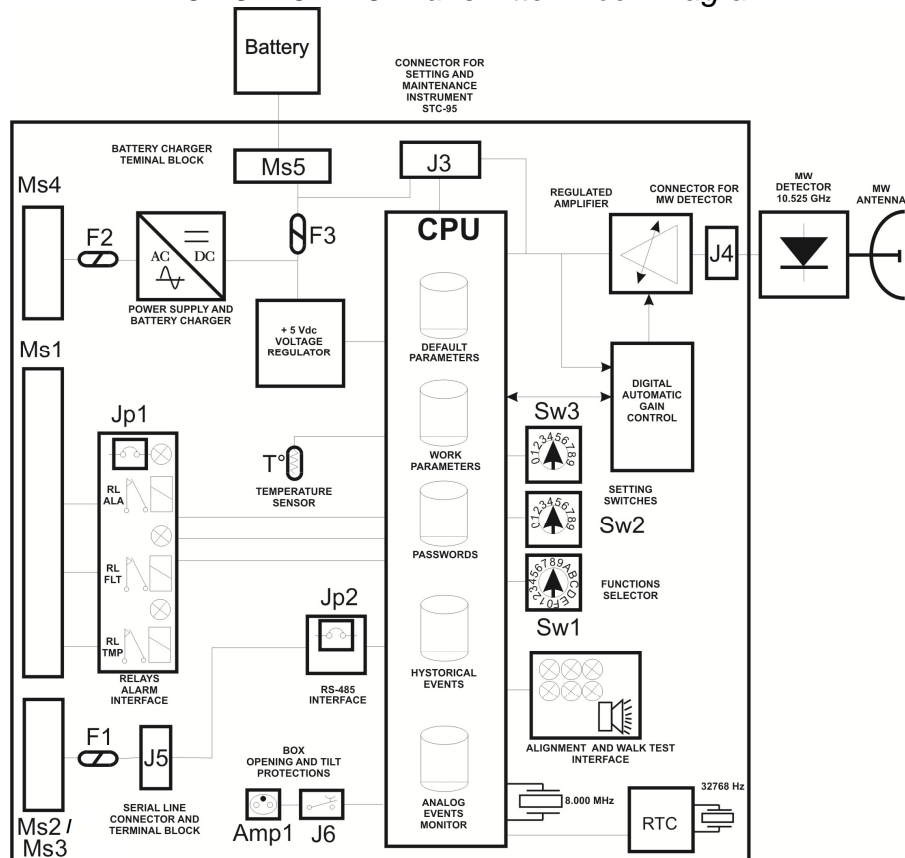

ERMO 482X3 PRO Receiver Block Diagram

2 INSTALLATION

2.1 Preliminary Information

Due to the various types of ERMO 482X3 PRO barrier, there are some different kinds of installation and fixing unit types related to user requirements.

2.2 Number of Sections

Having to design protection with volumetric barriers of a closed perimeter, besides having to split the perimeter within a certain number of sections that take into account the management need of the entire plant, it must be remembered that it is always preferable to install an **even number of sections**. This consideration is bound to the fact that the likely reciprocal interferences between adjacent sections are annulled should at the vertices (**cross**) of the polygon, resulting from the installation of the various sections, be installed **two equipment with the same name, two transmitters or two receivers**. It is evident that this might occur only if the number of sections is even. Should it not be possible to have an even number of sections then some careful considerations must be made on interferences that might likely occur in order to find the vertex point where retained best to place the transmitter near the receiver. The following pictures show some typical cases for which the most correct solution is given (see figure 1).

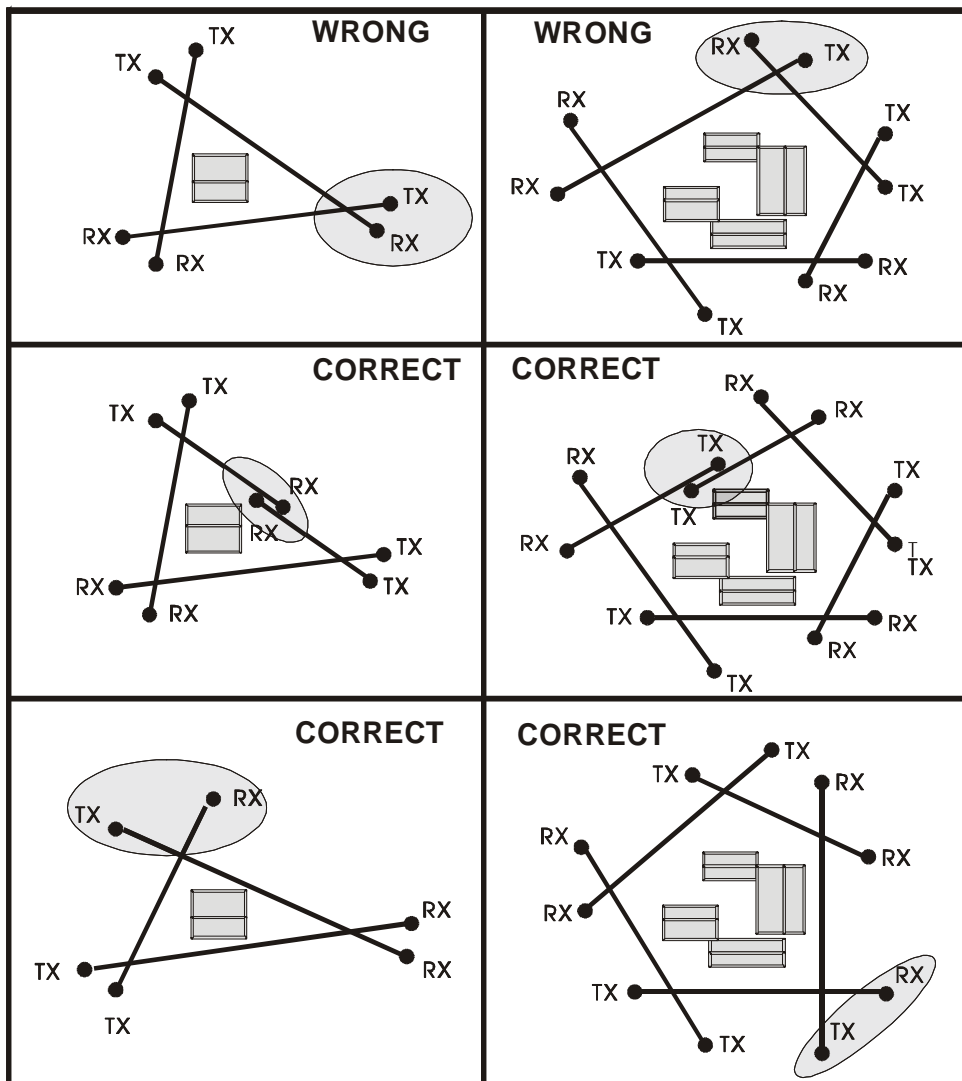

Figure 1

2.3 Ground conditions

It is inadvisable to install the equipment along sections with tall grass (more than 10 cm), ponds, longitudinal waterways, and all those types of grounds whose structure is rapidly mutable.

2.4 Presence of Obstacles

The **fences**, are generally **metallic** therefore highly reflecting hence causing various problems, for this reasons some precautions are suggested:

- first of all, make sure that the fence has been properly **fixed** in order that the wind does not move;
- if it is possible the microwave beam should **not** be placed in **parallel** to a metallic fence, is necessary to create a corner with it;
- metal fences placed behind the equipment night cause distortions to the sensitive beam especially, and might cause movement detection in unexpected spots, with subsequent likely generation of false alarms;
- in case of Mw barrier should be installed in a corridor between two metallic fences, the width of the **corridor** should be not less to **5 m**; if less contact CIAS technical assistance

Along the section, within the area of the protection field, are allowed pipes, poles or similar (e.g., lamp posts) as long as their dimensions, with respect to the protection beam, are not too excessive. **The trees, hedges, bushes in general**, need **very great attention** if near or within the protection beams. These obstacles vary in size and position, in fact they grow and they can be moved by the wind. Therefore, it is absolutely inadvisable to tolerate the presence of the cited obstacles within the protection sections.

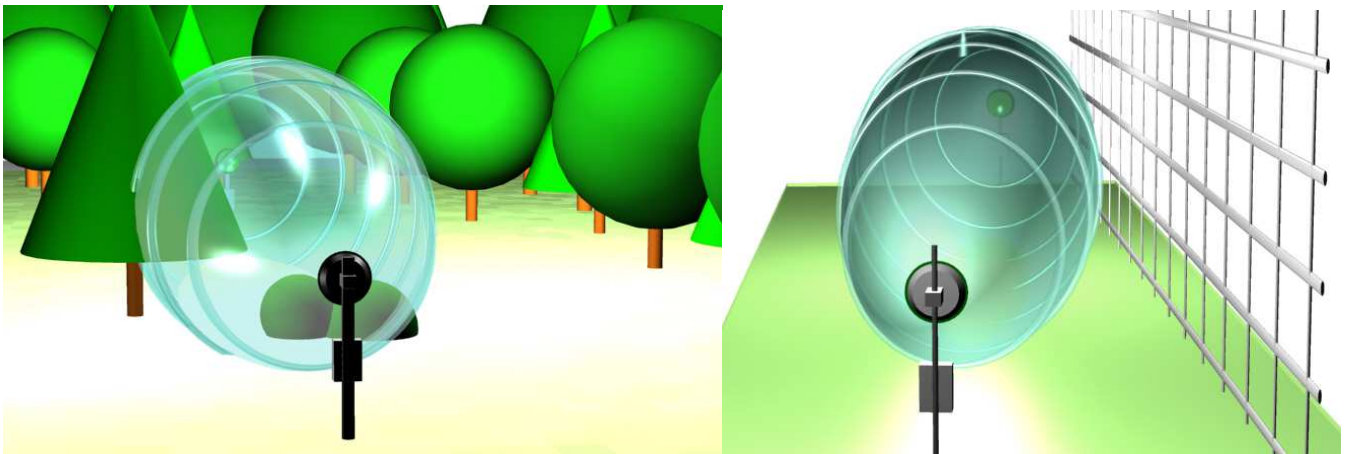

Figure 2

It is possible to tolerate the presence of these elements near the protection sections only if their growth is limited through routine maintenance, and if their movement is stopped through containment barriers. Various **Obstacles** might be present along the protection sections. For them there is the need to make the same considerations and take the same necessary precautions adopted for the above cases. This cause of **Dead zones** not protected and **Hypersensitive zones** which cause false alarm.

2.5 Amplitude of the Sensitive Beam

The amplitude of the **Sensitive Beam depends** on the distance between the transmitter and the receiver, on the **antenna type** and on the **sensitivity** adjustment set. The figures below state the diameter half-way of the sensitive beam section (based on the length of the section) in case of maximum and minimum sensitivity (see next figures).

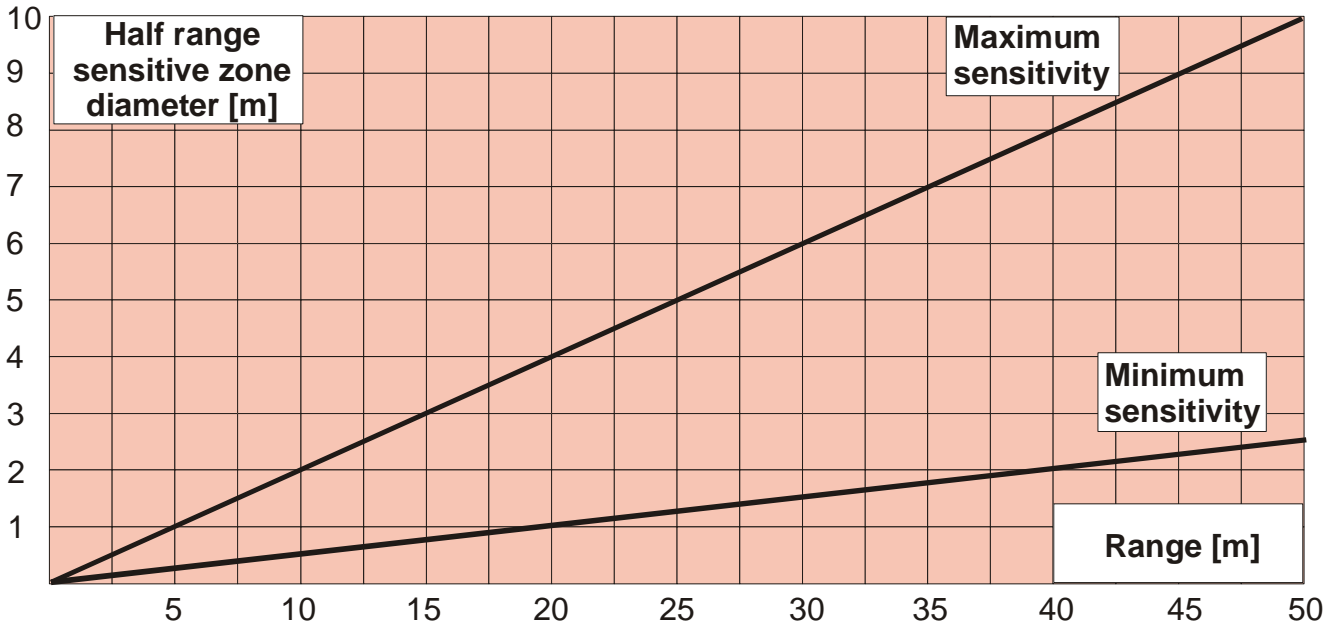

Figure 3 Diameter of sensitive beam at the half-section length (ERMO 482X3 PRO 50)

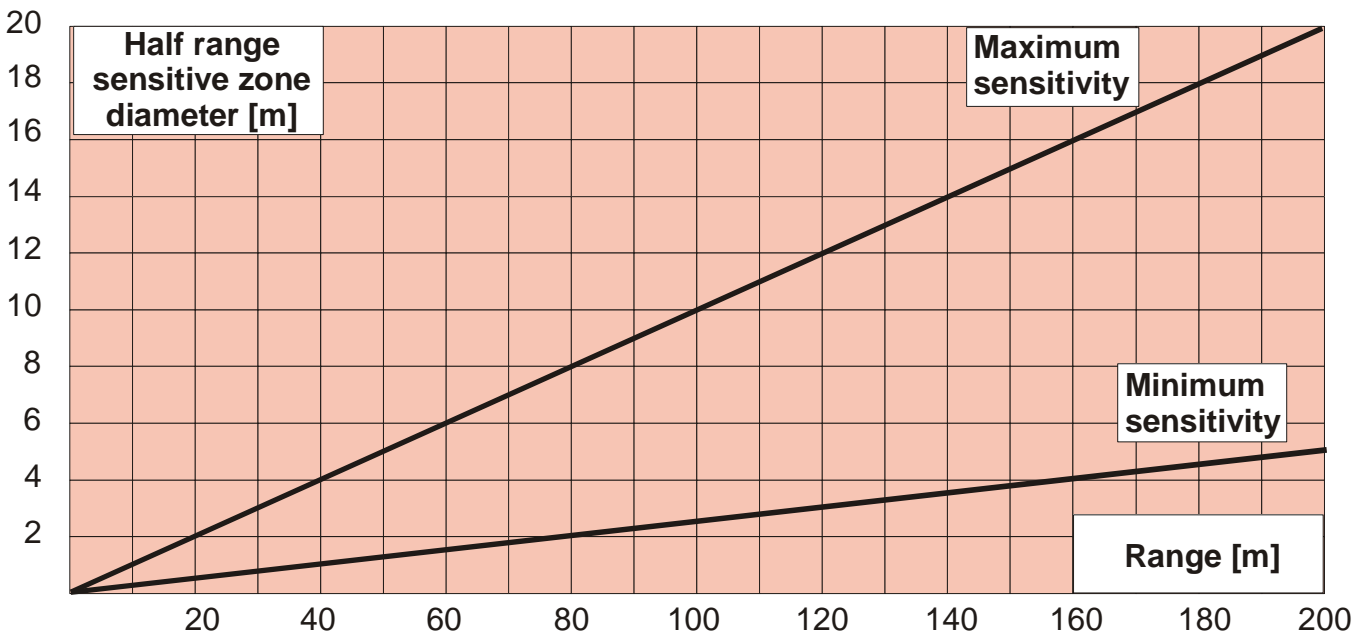

Figure 4 Diameter of sensitive beam at the half-section length (ERMO 482X3 PRO 80-120-200)

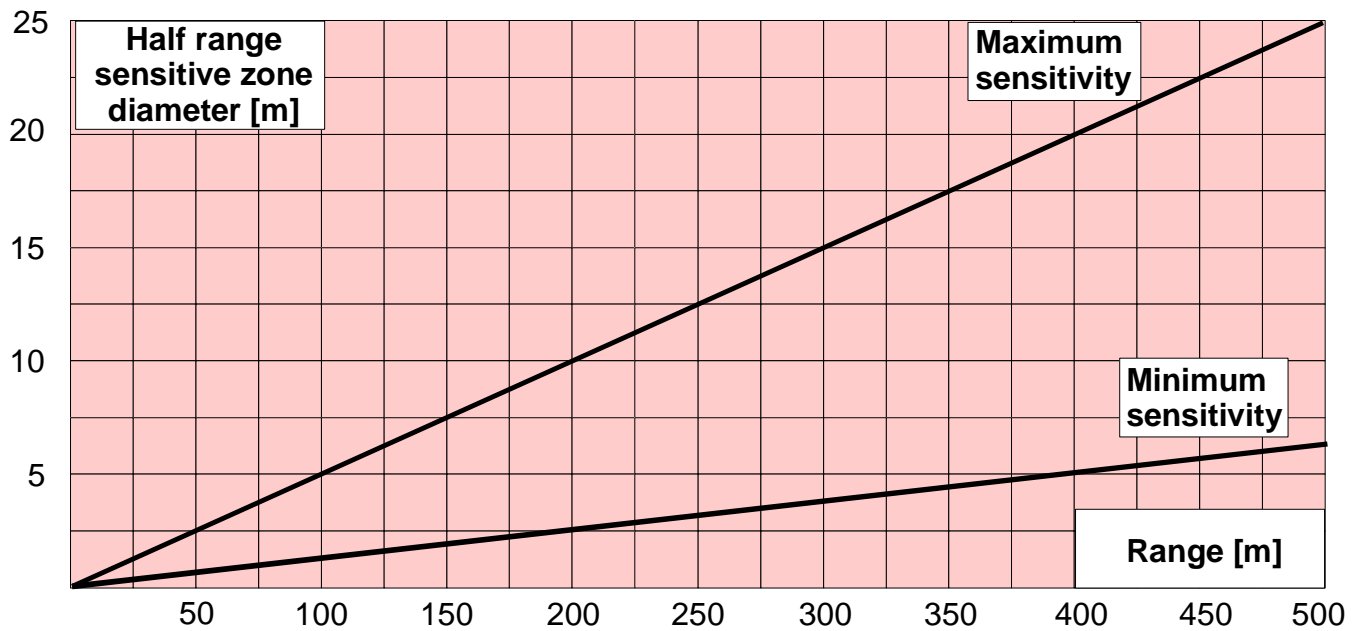

Figure 5 Diameter of sensitive beam at the half-section length (ERMO 482X3 PRO / 250-500)

Remark: that for the ERMO 482X3 PRO equipment, the sensitivity regulation to be considered to obtaining the dimensions of the sensitivity beam at half- section length, is that of the pre-alarm threshold. **The higher the pre-alarm threshold the lower the sensitivity, and vice versa.**

It's important to keep in mind that the **pre-alarm threshold** determines **the beginning of the intelligent analysis**: all signals below this threshold, are considered noise, and anyway of low importance. All the signals higher this threshold are analyzed following Fuzzy rules.

The prealarm and alarm thresholds, are settable both with software WAVE-TEST2 and with rotary switches on board on each receiver. Default setting corresponds to a medium sensitivity fightable for most of the cases.

2.6 Length of the Dead Zones near the equipment

The length of the **Dead Zones** near the equipment is based on the distance of the equipment from ground, on the sensitivity set on the receiver and on the type of antenna used.

With regard to the considerations stated above, and based on plant requirements, the equipment must be installed at a certain height from ground. **In mean plant the height must be 80 cm. from the ground and the centre of the equipment (90cm for 50-250-500m barriers).** With medium sensitivity setting, the suggested **crossing** overlap is **5m.**, for the 80-120-200m. **12,5m** for 250-500m barriers versions and **3,5m.** for the 50m. version.

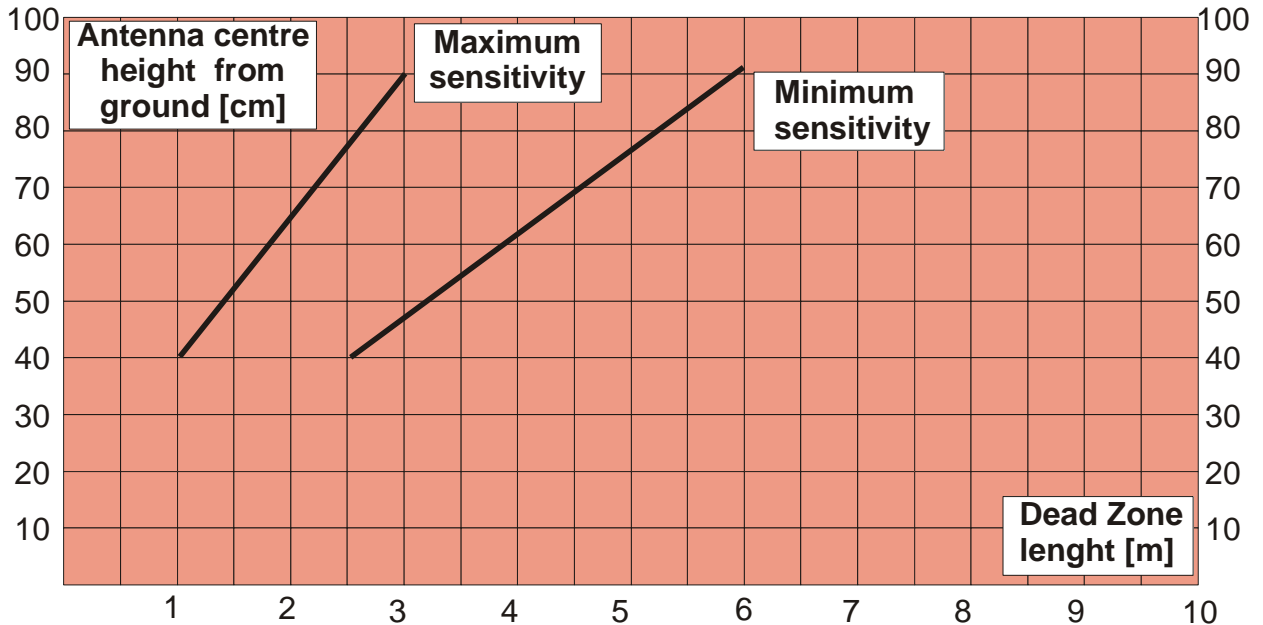

Figure 6 ERMO 482X3 PRO 50: Dead zone length near the equipment versus installation height.

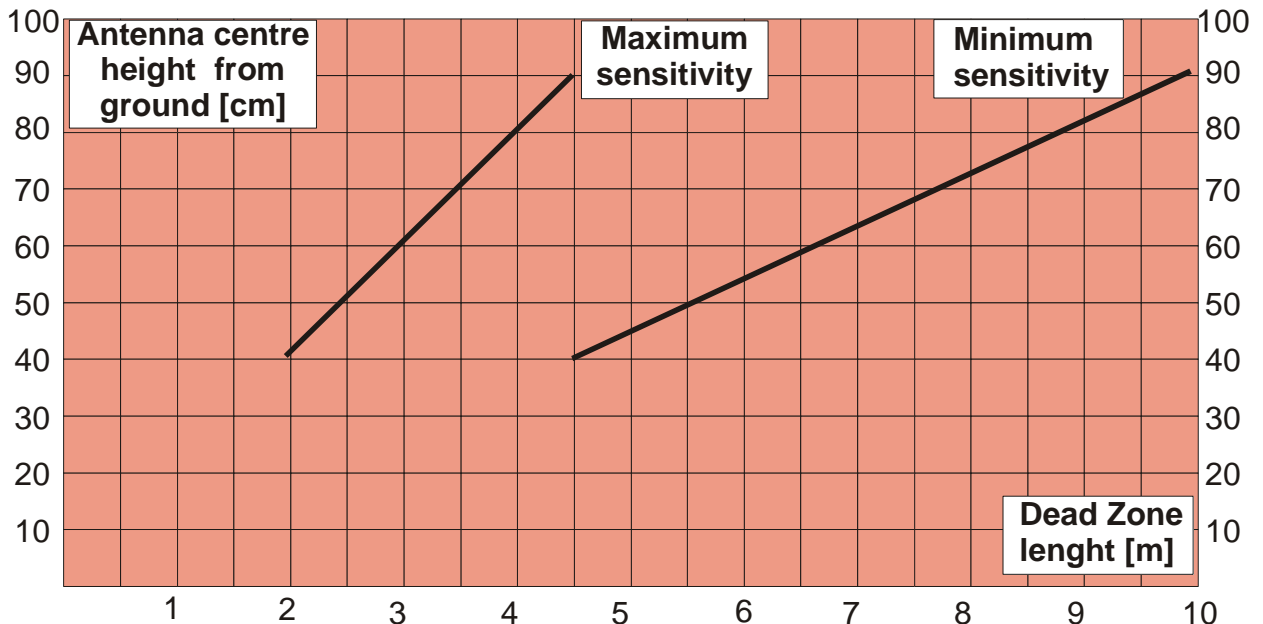

Figure 7 ERMO 482X3 PRO 80-120-200: Dead zone length near the equipment versus installation height.

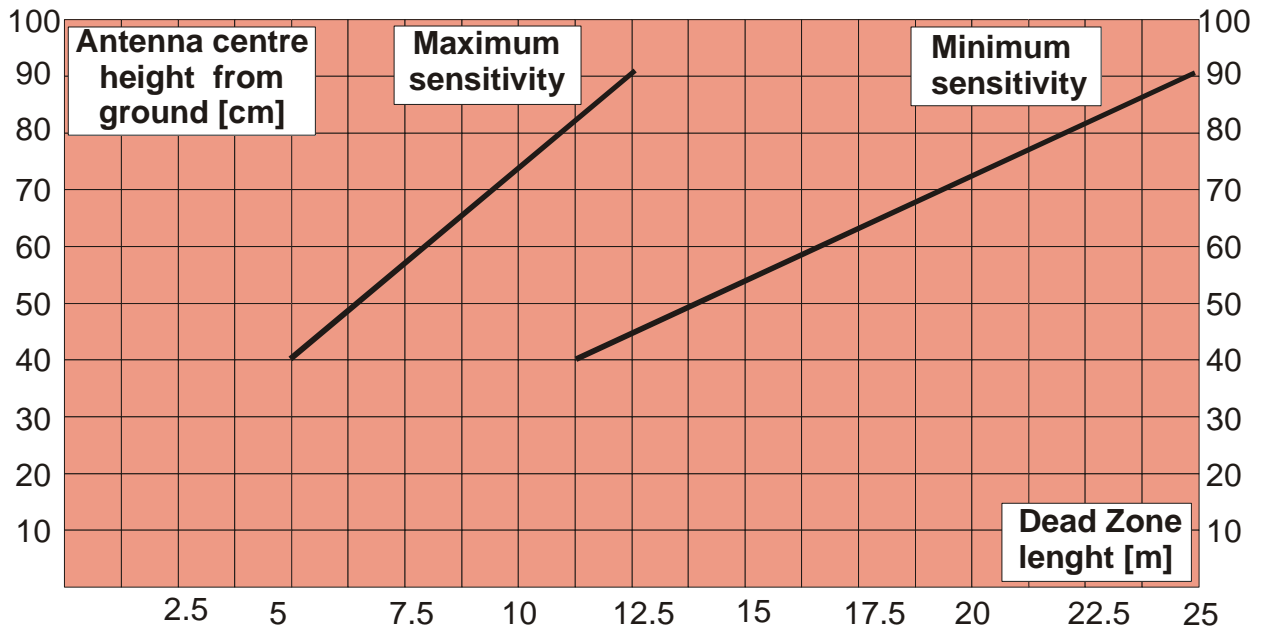
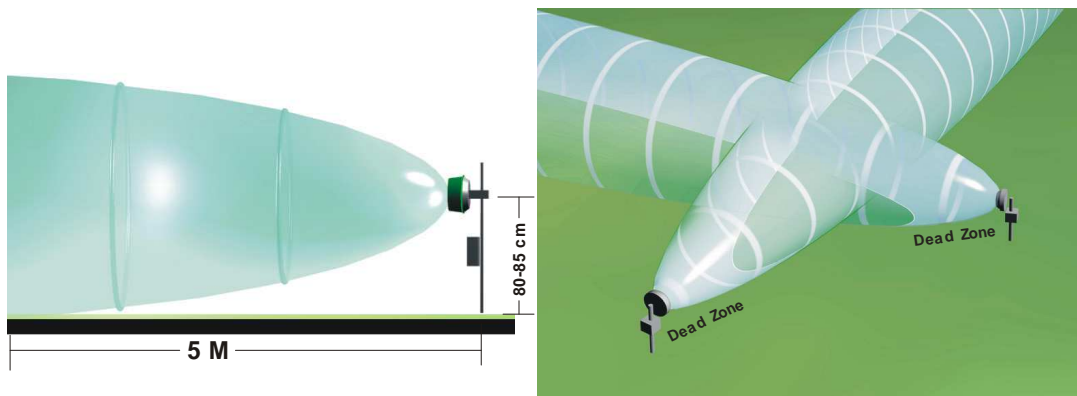
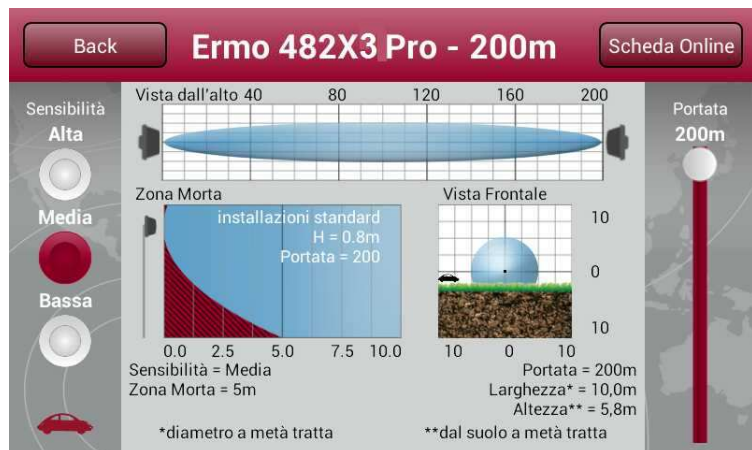

Figure 8 ERMO 482X3 PRO 250-500: Dead zone length near the equipment versus installation height.



2.7 How to calculate the size of the beam and dead zones

In order to calculate theoretically the dimension of the microwave beam and the dead zones generated with respect to the variable distance between TX and RX, CIAS has created a simple application called **CIAS Volumeter** available for free on our website: www.cias.it or on App Store to the following link: <https://itunes.apple.com/it/app/cias-volumeter/id409397666?mt=8> or on Google play to the following link: <https://play.google.com/store/apps/details?id=it.mi.action.ciasvolumeter>



2.8 Microwave working plane

The working plane is the surface which supports the microwave beam, granting the proper functioning of the barrier.

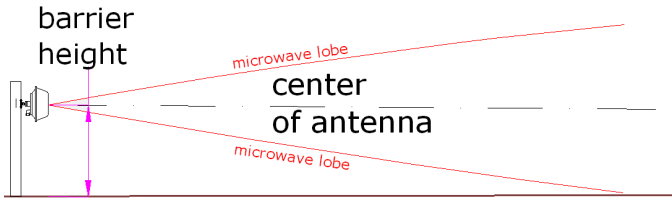

Microwave working plane

Distance between the center of the antenna and the working plane is called **height of the barrier** and must be chosen depending on the type of ground surface (asphalt, concrete, self-locking, grass, etc.).

- The working plane **MUST** necessarily be one.
- Near a wall or metallic fence it could happen that the microwave "consider" two planes, i.e. the wall/fence and the ground.
- The correct height is obtained through the incorporated alignment tools.
- Microwave field stability is required.

1° Example

Pole on the same level of microwave working plane

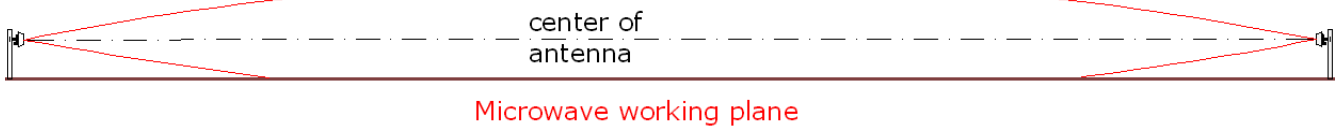

This is the simplest solution for installation, because the working plane is flat and the poles are at the same height.

2° Example (on a flowerbed or on a sidewalk)

Pole on a different level from the microwave working plane

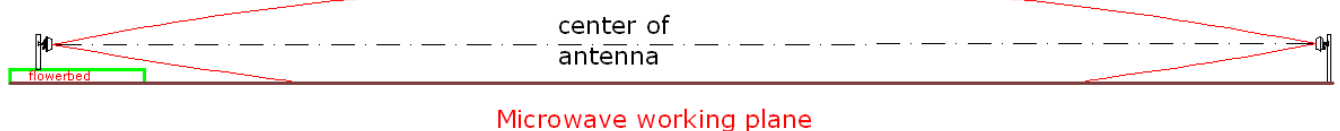

The head is mounted on a flowerbed at a higher level to facilitate, for example, the installation of a pole. The microwave lobe will then work on a different working plane.

3° Example (changing slope)

Pole on a different level from the microwave working plane

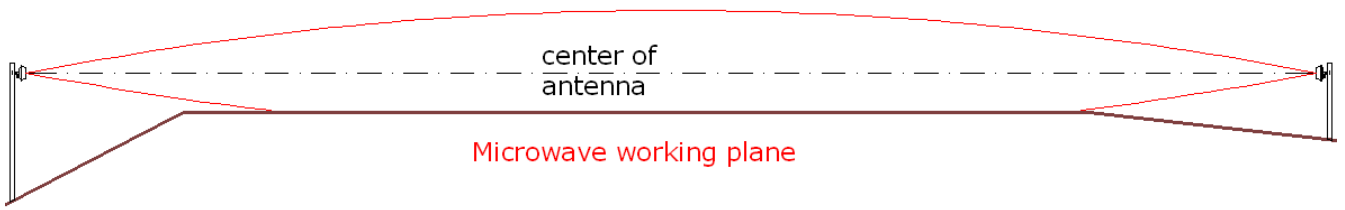

The head is installed on a changing slope or a valley; the microwave lobe will then work on a different working plane.

4° Example (changing slope, **suggested installation**)

Pole on a different level from the working plane, for installation on not-aligned working planes.

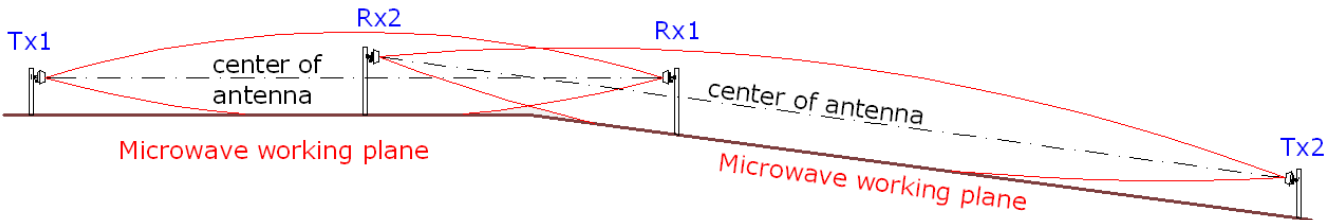

Tx1 is on a different working plane from Rx1 placed instead on the working plane of barrier 2.

5° Example (changing slope, **suggested installation**)

Pole on a different level from the working plane, for installation on not-aligned working planes.

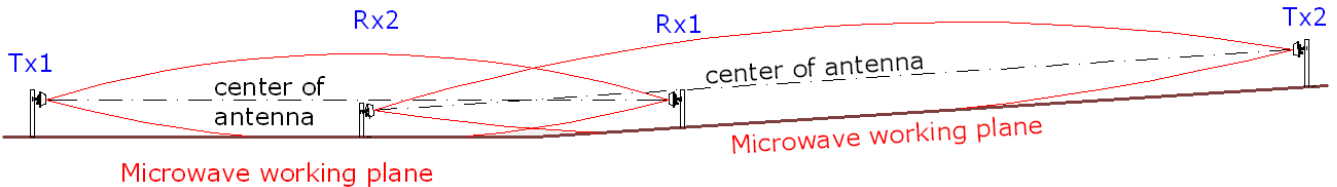

Tx1 is on a different working plane from Rx1 placed instead on the working plane of barrier 2.

6° Example (changing slope, installation not suggested)

Pole on a different level from the working plane, for installation on not-aligned working planes.

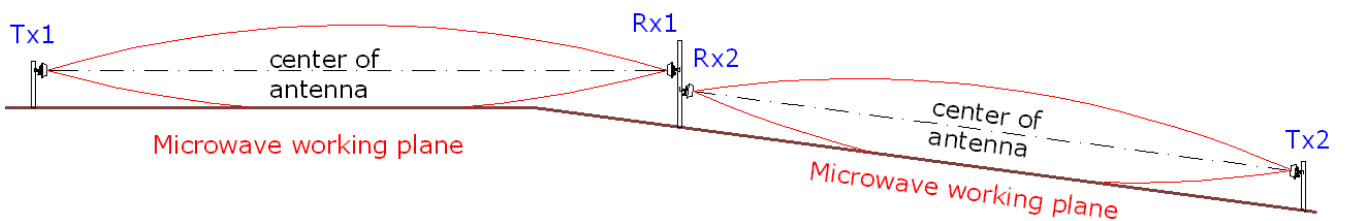

You can use a single pole, but resulting dead zones must be protected with two sensors.

7° Example (Change of slope in steps, not aligned working planes)

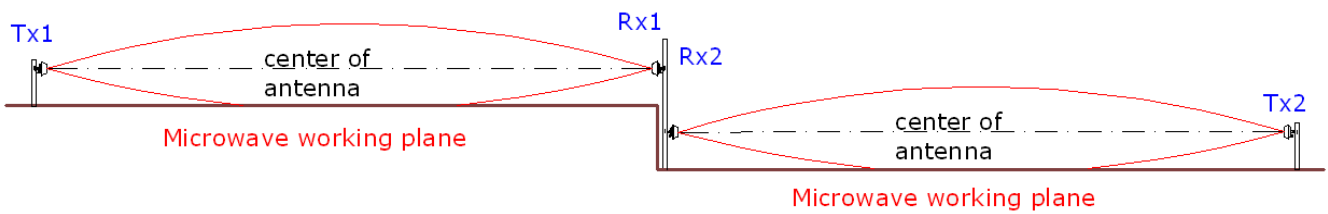

Barrier 1 is located on a different working plane than barrier 2.

In this case, since the change of slope is a step, you must install two separate barriers and consider two different working planes, always protecting dead zones resulting between Rx1 and Rx2 with two additional sensors.

8° Example (Strong dip in the ground)

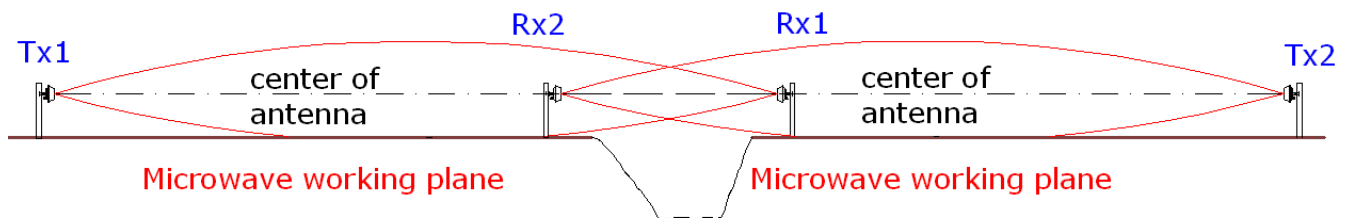

The strong dip in the ground creates a considerable dead zone that has to be protected with an additional sensor.

2.9 Wall installation

Besides perimeter protection, another possible application for MW barriers is wall installation for protection of windows, doors, front gates, driveways to villas, warehouses, and in general all those kind of facilities or facades for which that kind of protection is suitable.

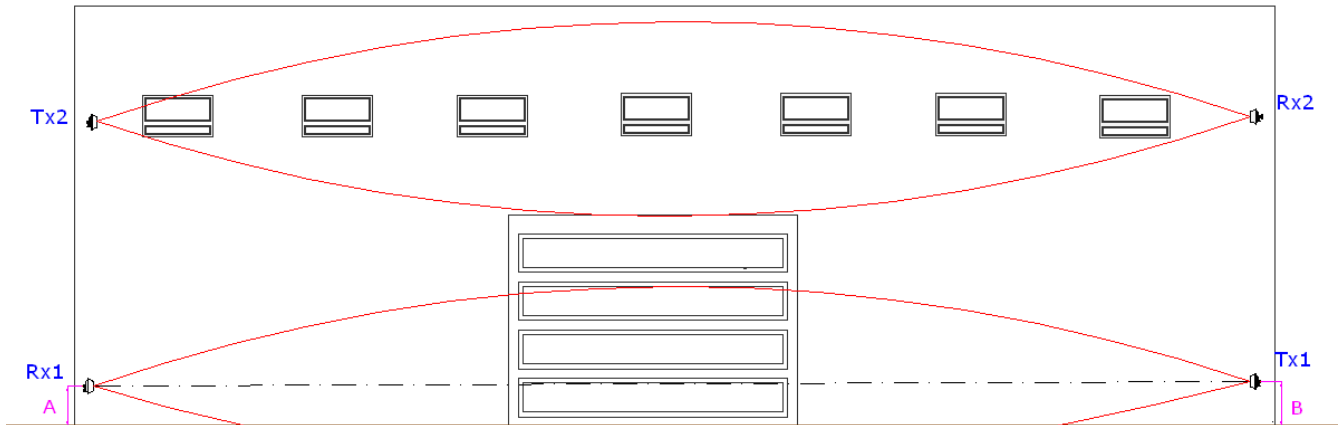

The facade/wall becomes the working plane for the barrier: take care to have just one working plane.

Take care of the following before installation:

- Use the right bracket according to distance
- Choose the right height according to kind of application (protection of windows or walls)
- Place the barrier taking into consideration the volume of its beam and relevant dead zone
- Check if the surface of the wall is free or with any obstacles (columns, drainpipes, gutters, window sills or else)
- Check on vegetation along the whole segment

We recommend to contact CIAS SERVICE. We'll be glad to provide you all required support and the relevant guide for wall installation.

3 CONNECTIONS

3.1 Terminal Blocks, Connectors and Circuits Functions

3.1.1 Transmitter Circuit

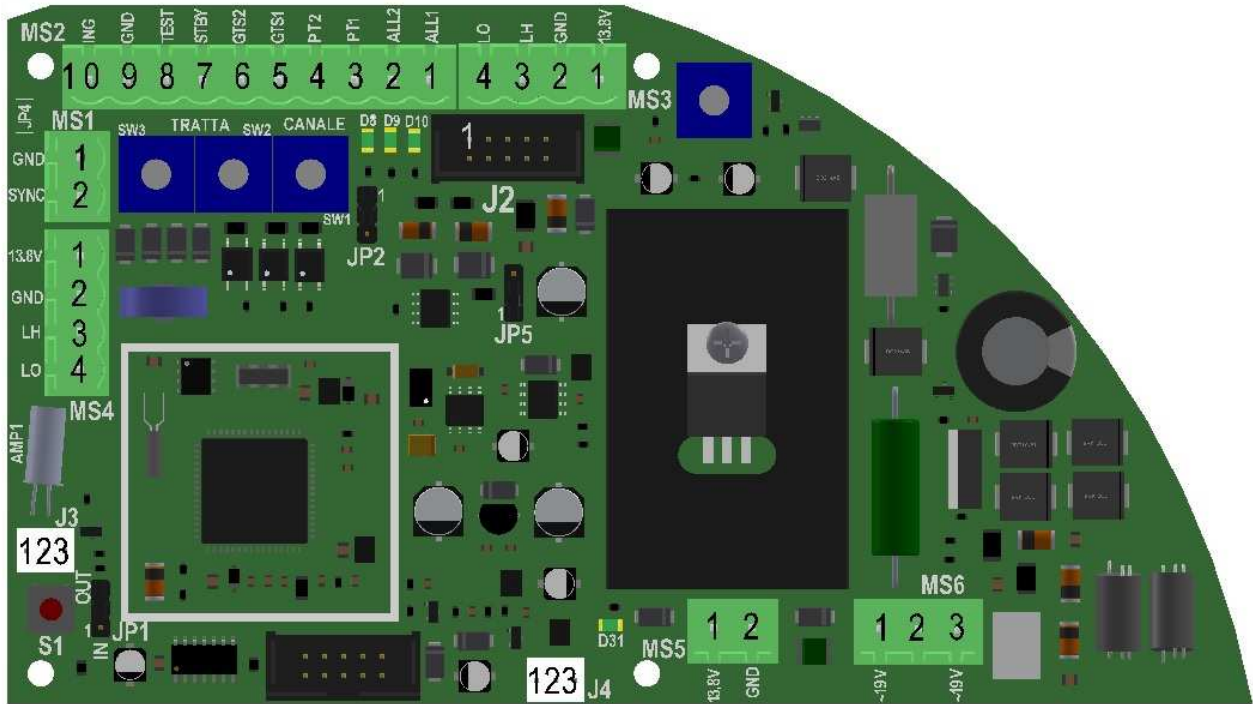

Figure 9 Layout of connectors, jumpers, LEDs and presetting in transmitter board

The following tables shows the connector pin functions present on ERMO 482X3 PRO Transmitter

TRANSMITTER TERMINAL BLOCK MS1		
Term	Symbol	Function
1	GND	Ground connection for sync cable
2	SYNC	Sync In/Out connection to perform Slave/Master operation setting JP1

TRANSMITTER TERMINAL BLOCK MS2		
Term	Symbol	Function
1	ALL 1	Alarm relay contact (Normally Closed)
2	ALL 2	Alarm relay contact (Normally Closed)
3	PT 1	Tamper relay contact (Normally Closed) + bulb contact (AMP1)
4	PT 2	Tamper relay contact (Normally Closed) + bulb contact (AMP1)
5	GST 1	Fault relay contact (Normally Closed)
6	GST 2	Fault relay contact (Normally Closed)
7	ST BY	Auxiliary input for Stand-By command (Norm. Open from GND)
8	TEST	Auxiliary input for Test command (Norm. Open from GND)
9	GND	Ground auxiliary connection
10	ING	Balanced Line Input for external device (detector)

TRANSMITTER TERMINAL BLOCK MS3 and MS4		
Term	Symbol	Function
1	+13,8	DC Power Supply (13,8 V \equiv)
2	GND	Ground connection for Data and Power Supply
3	LH	+ RS 485 (High Line)
4	LO	- RS 485 (Low Line)

TRANSMITTER TERMINAL BLOCK MS5		
Term	Symbol	Function
1	13,8V	+13,8 VDC Connection for Battery (Protection Fuse F3 = 1,1A)
2	GND	Ground connection for Battery

TRANSMITTER TERMINAL BLOCK MS6		
Term	Symbol	Function
1	19 V~	Mains ac power supply input (19 V~) or (24V \equiv)
2	N.C.	Not Connected
3	19 V~	Mains ac power supply input (19 V~) or (24V \equiv)

TRANSMITTER CONNECTOR J2		
10 pin Connector for direct PC Serial Line connection (Wave-Test2 SW)		
Term	Symbol	Function
1/2	N.C.	Not Connected
3	+13,8	Power Supply (13,8 V \equiv) Converter interface RS-485/232
4	N.C.	Not Connected
5	LO	Low Line for RS 485
6	N.C.	Not Connected
7	LH	High Line for RS 485
8	N.C.	Not Connected
9	GND	Ground
10	N.C.	Not Connected

TRANSMITTER CONNECTOR J3		
Micro switch Connector for Radome Tamper		
Term	Symbol	Function
1	GND	Ground connection for Tamper
2	ING	Tamper Input
3	GND	Ground connection for Tamper

TRANSMITTER CONNECTOR J4		
Connector for MW oscillator (DRO)		
Term	Symbol	Function
1	GND	Ground connection for MW oscillator
2	DRO	Modulation Frequency connection for MW oscillator
3	GND	Ground connection for MW oscillator

TRANSMITTER CHANNELS SWITCH	
Symbol	Function
SW1	Hexadecimal Modulation Channel Selector

TRANSMITTER NUMBER OF BARRIER SWITCHES SW2 SW3	
Symbol	Function
SW2	Barrier Number selector (units column)
SW3	Barrier Number selector (tens column)

TRANSMITTER LEDS		
Symbol	Function	Default
D8	Fault indication (OFF by means of Jp2)	ON
D9	Tamper indication (OFF by means of Jp2)	ON
D10	Alarm indication (OFF by means of Jp2)	ON
D31	Main presence indication	ON

TRANSMITTER JUMPERS		
Symbol	Function	Default
Jp1	Internal Modulation signal (Jp1 position 2/3 Tx-Master, Sync-Out) or External Modulation signal (Jp1 position 1/2 Tx Slave, Sync-In)	OUT
Jp2	Exclusion for fault, tamper and alarm indication Leds (Jp2 position 2/3 leds OFF)	ON
Jp4	Enable / Disable Balanced Line Input (Closed = Input disabled)	OFF
Jp5	RS485 Line termination (Jp5 position 2/3 line terminated)	OFF

3.1.2 Receiver Circuit

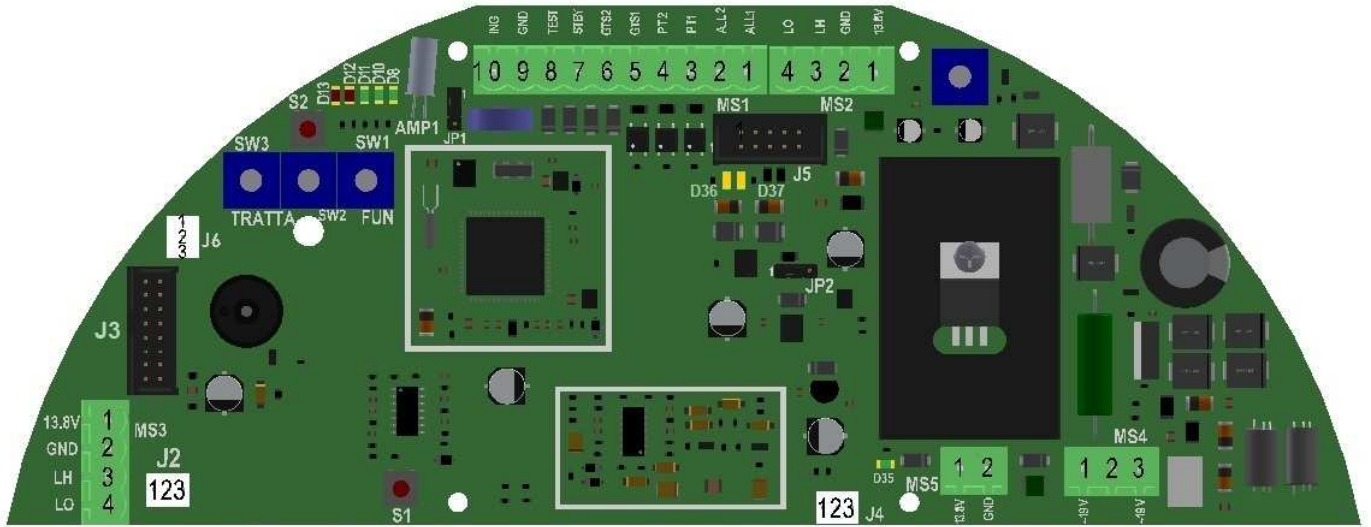

Figure 10 Layout of connectors, jumpers, LED and presetting in receiver board

The following tables shows the connector pin functions present on ERMO 482X3 PRO Receiver board.

RECEIVER TERMINAL BLOCK MS4		
Tem	Symbol	Function
1	19 V~	Mains ac power supply input (19 V~) or (24V \equiv)
2	N.C.	Not Connected
3	19 V~	Mains ac power supply input (19 V~) or (24V \equiv)

RECEIVER TERMINAL BLOCK MS1		
Term	Symbol	Function
1	ALL 1	Alarm relay contact (Normally Closed)
2	ALL 2	Alarm relay contact (Normally Closed)
3	PT 1	Tamper relay contact (Normally Closed) + bulb contact
4	PT 2	Tamper relay contact (Normally Closed) + bulb contact
5	GST 1	Fault relay contact (Normally Closed)
6	GST 2	Fault relay contact (Normally Closed)
7	ST BY	Auxiliary input for Stand-By command (Norm. Open from GND)
8	TEST	Auxiliary input for Test command (Norm. Open from GND)
9	GND	Ground auxiliary connection
10	ING	Balanced Line Input for external device (detector)

RECEIVER TERMINAL BLOCK MS5		
Term	Symbol	Function
1	+13,8	+13,8 VDC Connection for Battery (Protection Fuse F3 = 1,1A)
2	GND	Ground connection for Battery

RECEIVER TERMINAL BLOCK MS2 and MS3		
Term	Symbol	Function
1	+13,8	DC Power Supply (13,8 V \equiv)
2	GND	Ground connection for Data and Power Supply
3	LH	+ RS 485 (High Line)
4	LO	- RS 485 (Low Line)

RECEIVER CONNECTOR J4 Connector for MW detector		
Term	Symbol	Function
1	GND	Ground connection for MW oscillator
2	DET	Connection for MW detector
3	GND	Ground connection for MW oscillator

RECEIVER CONNECTOR J3		
Term	Symbol	Function
1/2/3/5/7/8/10/ 11/12/13/15/16	N.C.	Not Connected
4	-	GND
6	+	Power Supply (13,8 V \equiv)
9	0,2V	200 mVpp Square Wave
14	VRAG	Automatic Gain Control Voltage

RECEIVER CONNECTOR J6 Micro switch Connector for Radome Tamper		
Term	Symbol	Function
1	GND	Ground connection for Tamper
2	ING	Tamper input
3	GND	Ground connection for Tamper

RECEIVER CONNECTOR J5 10 pin Connector for direct PC Serial Line connection (Wave-Test2 SW)		
Term	Symbol	Function
1/2	N.C.	Not Connected
3	+13,8	Power Supply (13,8 V \equiv) converter interface RS-485/232
4	N.C.	Not Connected
5	LO	Low Line for RS 485
6	N.C.	Not Connected
7	LH	High Line for RS 485
8	N.C.	Not Connected
9	GND	Ground
10	N.C.	Not Connected

RECEIVER JUMPERS		
Symbol	Function	Default
Jp1	Leds OFF from D8 to D13 (Jp1 position 1/2 = Leds ON)	ON
Jp2	RS 485 Line termination (Jp2 position 2/3 line terminated)	OFF

RECEIVER LEDS		
Symbol	Function	Default
D11	Fault indication + Alignment and setting functions	ON
D10	Tamper indication + Alignment and setting functions	ON
D8	Alarm indication + Alignment and setting functions	ON
D12	Alignment and setting functions	OFF
D13	Alignment and setting functions	OFF
D35	Main presence indication	ON
D36	Transmission communication indication	-
D37	Reception communication indication	-

SET -UP BUTTON FOR ALIENEMENT AND SETTING	
Symbol	Function
S2	Button to accept data in alignment operation and to write parameter in setting operations

RECEIVER FUNCTION SWITCH SW1	
Symbol	Function
SW1	<p><i>16 positions functions rotary switch:</i></p> <ul style="list-style-type: none"> Position 1 = Barrier alignment Position 2 = acquisition, of the installation values (Channel number and AGC Voltage) Position 3 = Prealarm thresholds Read/Write Position 4 = Alarm thresholds Read/Write + Walk-Test Position 5 = Masking thresholds Read/Write Position 6 = Upper Prealarm thresholds Read/Write (FSTD) Position 7 = Upper Alarm thresholds Read/Write (FSTD) Position 8 = Barrier number Read/Write Position 9 = Monitor thresholds Read/Write Position A = Upper Monitor thresholds Read/Write Position B = Battery Efficiency Test Read/Write Position C = Save Prealarm Event Position D = Not Used Position E = Not Used Position F = Balanced Line Active/Inactive Position 0 = Alignment procedures ending

PARAMETERS AND BARRIER NUMBER READING AND SETTING SWITCHES SW2- SW3	
Symbol	Function
SW2	Decimal rotary switch to read or to set parameters during the alignment operations (units column)
SW3	Decimal rotary switch to read or to set parameters during the alignment operations (tens column)

3.2 Equipment Connection to the Power Supply

Even if the equipment is Direct Current powered (13,8 V \equiv), they still operate properly, but it is advisable to power it by Alternating Current (19 V \sim) or (24 V \equiv).

3.2.1 Connection to the Power Supply

The connection between the equipment and the transformer must be as short as possible (less than 4 meters), and the section of the conductor must not be less than 1.5 mm². The connection between the transformer and the 230 V \sim mains will be as that of the previous one. The power supply cables connecting transformer with equipment, must be of shielded type with shield connected to ground. The connection between unit and the power supply must be realised with cables of correct section, the cables section must be computed keeping in account connection length and unit current absorption. For the power supply connection (Alternating Current) 19V \sim , to make connect term 1/3 on the terminal strep MS6 (for Tx circuit) or MS4 (for Rx circuit).

The protection fuse is F2 and it is a 1.85 A resettable fuse.

Use only safety **transformers** with the following characteristics:

- primary voltage: 230 V \sim
- secondary voltage 19 V \sim
- minimum power 30 VA

Remark: use only safety transformers (example Certified EN 60950)

Make sure to connect the body of the transformer to hearth tap.

The transformer connection to the main (230 V \sim), must be carried out through one circuit breaker having the following characteristics:

- bipolar with minimum distance between contacts equal to 3 mm
- provided in the fix part of cabling
- easily accessible

However laws and standards concerning installations of devices permanently connected to the main (230 V \sim), must be strictly respected (in Italy Law 46/90 and standard CEI 64-8).

3.2.2 Connection of stand-by Battery

Into each equipment heads there is the housing for an optional rechargeable back-up lead Battery 12 V \equiv – 2 Ah (optional). The battery is charged by the internal power supply, through the red and black faston and wires connected to the terminals 1 and 2 of the terminal block MS5 of the Rx and Tx circuit. The provided protection fuse (against overload and/or battery polarity inversion) is a 1.1 A resettable fuse. The back-up lead battery allows to the barrier head (TX or RX), at least 12 hours of perfect working, in case of mains missing.

Remark 1: Package, of the optional standby battery, must have a flame class equal or better than HB (UL 94 Standard). **We recommend to use quality batteries and programmed maintenance every six months.**

Remark 2: The terminals block MS5 where the battery is connected must be only used to connect the battery.

The microprocessor controls the presence of the battery, the battery charge and performs the test of the battery's goodness.

Both the Tx and Rx boards have an automatic control of the standby battery status. This check takes place every Monday at 8:30 am for both boards but, in the Tx, only if the standby battery is present while in the RX you can enable or disable it through the function switch SW1. At the end of the test, if the battery should be exhausted, it will no longer be recharged.

3.3 Connection to the Control Panel

3.3.1 Alarm contacts: Alarm, Tamper, Fault

On transmitter and receiver PCB are present 3 relays. These Relays are static with dry contacts normally closed. By means of these contacts it's possible to communicate to the control panel the following conditions:

- **ALARM, TAMPER, FAULT**

There are also 3 inputs to activate the following functions:

- **Test (TX and RX)**
- **Stand-by (TX and RX)**
- **Synchronism (only TX)**

The output contacts for alarm, tamper and fault, both on transmitter and receiver, are made by Static Relays with maximum current of 100 mA.

Remark: in closed condition the resistance of these contact is about 40 ohm.
The connections to control panel must be made by means of shielded cables.
The relays are activated for the following reasons:

- ALARM RELAYS

- 1- Stopped target alarm on receiver (**Remark1**)
- 2- Intrusion alarm on receiver
- 3- Receiver masking condition alarm
- 4- Alarm of external detector connected at Auxiliary Balanced Line
- 5- Successful result of test procedure operation on receiver
- 6- Insufficient received signal ($V_{RAG} > 5,5V$)
- 7- Channel alarm (**Remark2**)

- TAMPER RELAYS

- 1- Cover removing (radome) (TX and RX)
- 2- Tilt Bulb position (TX and RX)
- 3- Tampering of external detector connected at Auxiliary Balanced Line
- 4- Cut of Auxiliary Balanced Line
- 5- Short circuit of Auxiliary Balanced Line.

- FAULT RELAYS

- 1- Battery voltage low ($< +11V_{DC}$)
- 2- Battery voltage high ($> +14.8V_{DC}$)
- 3- Temperature low ($< -35^{\circ}C$ internal)
- 4- Temperature high ($> +75^{\circ}C$ internal)
- 5- Fault of external detector connected at Auxiliary Balanced Line
- 6- RF (radio frequency) or BF (low frequency) Oscillator fault on Transmitter
- 7- Mains missing or power supply fault (more then 3 hours)
- 8- Battery test activated and backup battery not installed

Remark 1: if the intrusion signal, after overcoming the pre-alarm threshold, stays for 40 sec between pre-alarm and alarm threshold, the barrier gives a "Stopped target alarm" event, and the alarm output is activate (the contact become opened).

Remark 2: if transmitter is set-up on channel F, the alarm won't be given.

3.3.2 Synchronism connection

For the Synchronism operation between two Transmitters, it is necessary to interconnect the terminals 2 “**SYNC**” and 1 “**GND**” of terminal block MS1 of both Transmitters.

It is also necessary to select one Transmitter as “**Master**” and the other as “**Slave**”, by means of jumper Jp1.

- Jp1 = “**IN**” position, the terminal 1 of MS1 is the input for an external synchronism signal, so the Transmitter is “**Slave**”.
- Jp1 = “**OUT**” position, the terminal 1 of MS1 is the output for the synchronism signal internally produced, so the Transmitter is “**Master**”

Remark: the cable connecting the two transmitters, must be as short as possible and not more than 10 meters. If cables longer than 10 meters are required, it is necessary to use the synchronism repetition circuit mod. SYNC 01.

3.3.3 Stand-by connection

For the Stand-by function activation, it is necessary connect to ground the terminal 7 “**STBY**” of MS1 terminal block for the receiver circuit and connect to ground the terminal 7 “**STBY**” of MS2 terminal block for the transmitter circuit.

Remark: the Stand-by operation, doesn't inhibit the barrier functionality, but deactivate the record of events into “historical file” (TX and RX) and in the monitor file (RX).

3.3.4 Test connection

The Test function will be activated connecting to ground the terminal 8 “**TEST**” of the terminal block MS2 on Transmitter circuit. If the test procedure is successful done, the alarm relays on Receiver circuit will be activated later 10 second.

Remark: for high risk protection it's necessary a Periodic Test for the equipments. Performing tests, the control panel will be able to detect tamper action.

3.3.5 Balanced Line connection

Either on transmitter and receiver PCB is provided a Balanced input were it's possible to connect an external detector and manage its activity trough each head (TX or RX). To activate this function on the TX PCB, it's necessary to open Jp4 tinny jumper. To activate this function on the RX PCB, it's necessary to end the alignment procedure, leaving the function selector SW1 in position F. The balanced inputs are provided at terminals 10 (ING) and 9 (GND) on terminal block MS2 of the transmitter PCB, and MS1 of the receiver PCB. By these inputs it's possible to manage the following conditions of external detectors:

- rest condition of external detector
- alarm condition of external detector
- tamper condition of external detector
- fault condition of external detector

In addition it's possible to manage the following conditions:

- Line cut condition of the wires connecting the external detector at TX or RX PCB
- Short Circuit condition of the wires connecting the external detector at TX or RX PCB

To manage all these conditions it's necessary to use weighting resistors connected like that showed in the following picture.

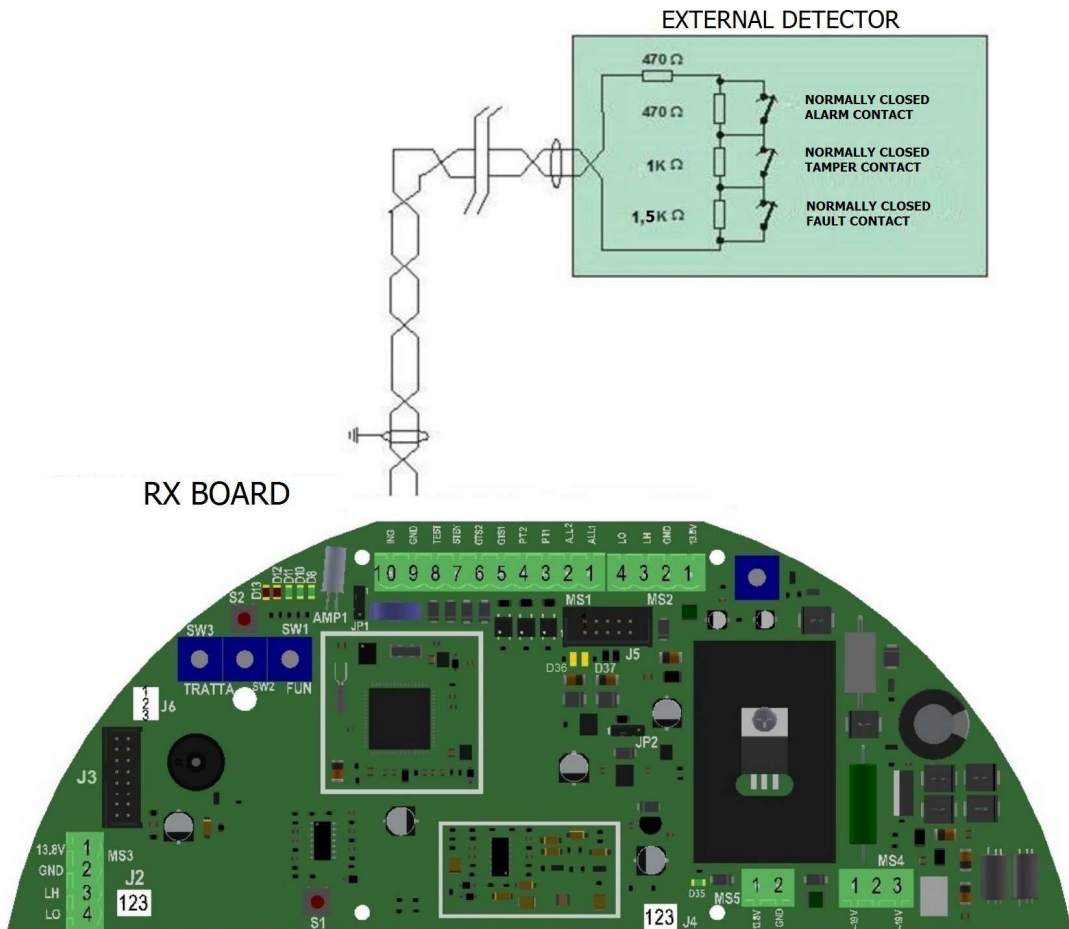

In the following table are indicated the voltage values present at balanced inputs for the possible, detector and line, conditions. It is possible to read this values, also by means of WAVE-TEST2 SW in the “Analogue values” window. **(PC in local or remote connection)**

CONDITIONS	INPUT VOLTAGE [V dc]		
	Min.	Average	Max.
LINE CUT	4.5	-	5
FAULT	3.5	4	4.5
TAMPER	2.5	3	3.5
ALARM	1.5	2	2.5
REST	0.5	1	1.5
LINE SHORT CIRCUIT	0	-	0.5

3.4 Serial Line RS-485

3.4.1 RS - 485 / 232 / USB Network Connection Interface

A standard RS 485 serial interface is provided on both transmitter and receiver of the ERMO 482X3 PRO barrier. The communication parameters are the following:

Mode: Asynchronous - Half-Duplex
 Baud rate: 9600 b/s
 Character length: 8 bit
 Parity control: No Parity
 Stop bit: 1

3.4.2 RS -485 Serial Line connections

The way of laying down the cable must be “multidrop” type (BUS), and the derivations for units connection as short as possible. It is possible to use others cabling configurations like: full Star type, mixed, Star and BUS type. Connect to the terminal 4 “LO” (“RS 485 –“ negative data line); to the terminal 3 “LH” (“RS 485+” positive data line) and to the terminal 2 “GND” (data ground line) of the terminal block MS2/MS3 for the Receiver PCB and MS3/MS4 for the Transmitter PCB. To connect a PC on serial line is necessary to use a serial line converter RS 485/232, to connect a PC with a USB port you must use the USB-RS485 conversion included in WAVE-TEST2 sw.

Cable for connection of all the heads Rx and Tx To the maintenance P. C. with WAVE-TEST2 Software				
Connector interface MS3/MS4 (Tx), MS2/MS3 (Rx)	Connector 25 pin	Terminal block converter USB-RS485		
N°	N°		Symbol	Function
1	12		+13,8	Power supply (13,8 VDC) per for 485/232 converter
2	9	1	GND	Ground data and power supply for 485/232 converter
3	10	2	LH 485	High Line for RS 485
4	11	3	LO 485	Low Line for RS 485

3.4.3 Network Configuration and Signal Repeaters

The interconnection cable concerning barrier management through a remote P.C. must be suitable for a RS485 serial data line, i.e., it must be a **low capacity cable with 3 twisted and shielded leads (70 pF/mt.)** for example “Belden 9842”. The limit distances of the RS 485 connection is 1200 meters. For longer distances use one or more interface Regenerators (BUS REP). The way of laying down the cable must be of BUS type, and the derivations for units connection as short as possible. It is possible to lay down the cable in different manner: full stellar; mixed, stellar and BUS type, using Repeaters / Regenerators and interface multipliers BUS REP (see figures pag.62). The total number of units (Tx and Rx) that can be connected to the line are 32, for an higher number of units, it is necessary the use of one or more line regenerator RS 485, this is true also in case of cable length lower than 1200 metres. Screen connection continuity must be guaranteed to properly protect the cited line from induced noise. To this concern the screen will have to be GROUNDED only in one point, i.e., near the power supply unit. The power supply voltage to the RS485 / RS 232 interface converter must be delivered by a local power supply unit, which will have to be placed near the converter proper for the central COM-BS connection, the serial line coming from the barriers can be used directly without any conversion.

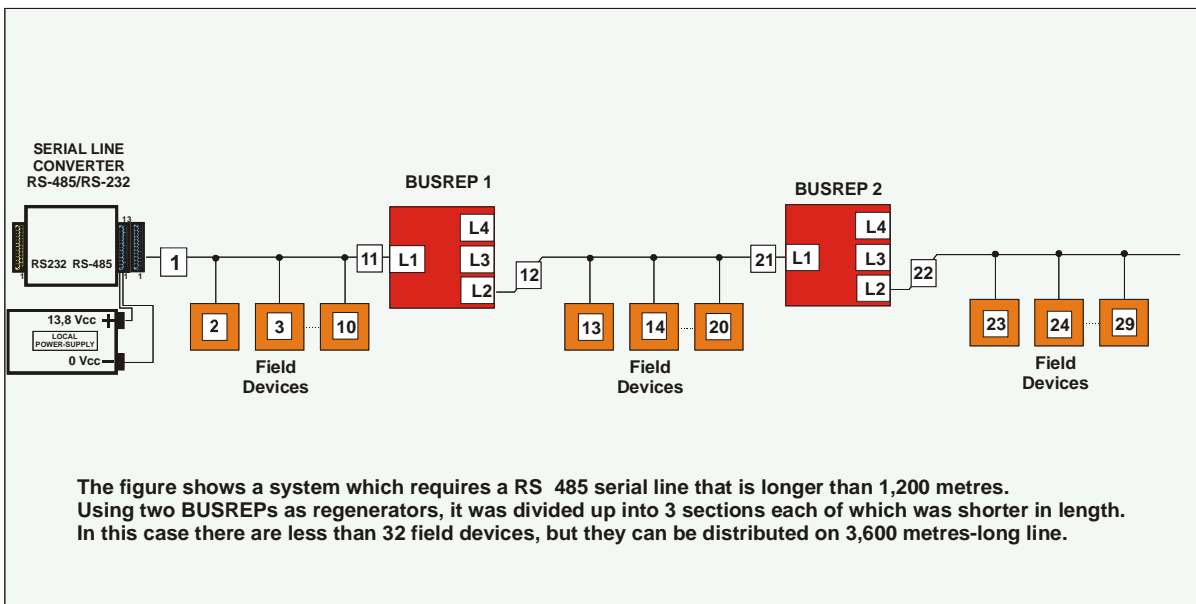
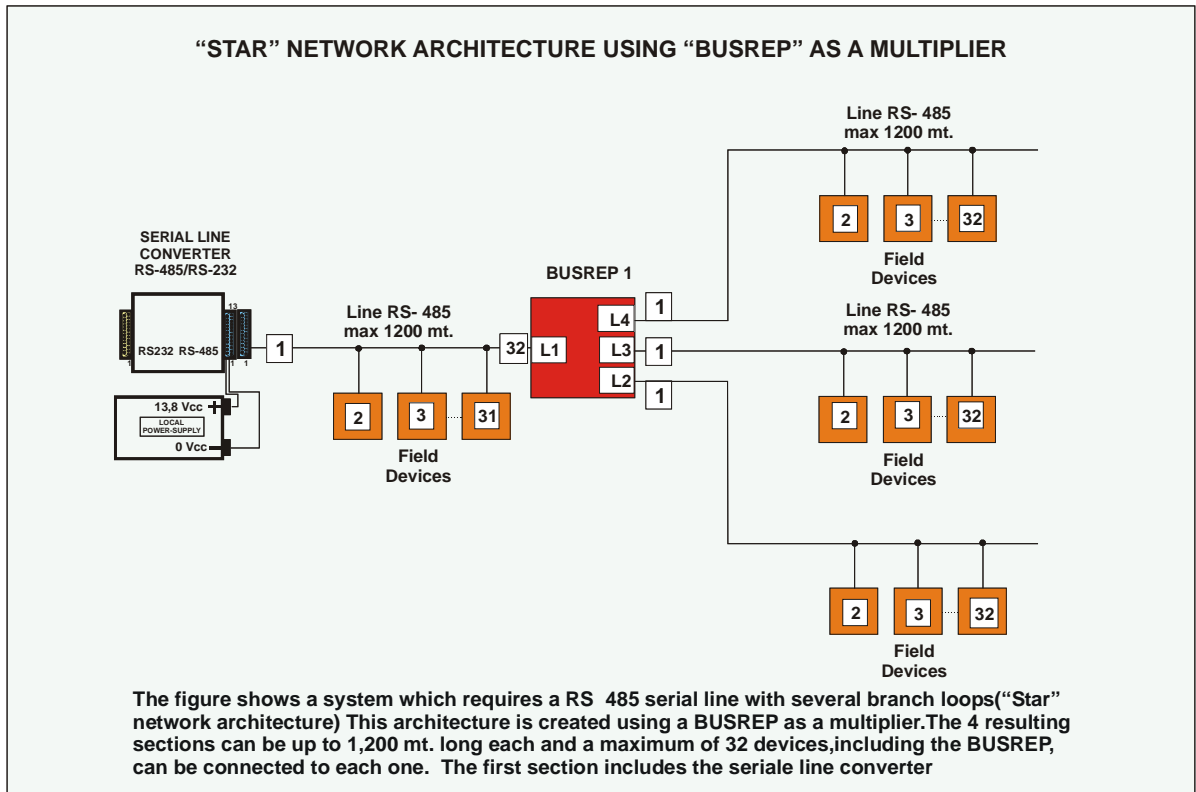

4 ADJUSTMENT AND TESTING

4.1 Adjustment and Testing

A built in electronic alignment, parameter set and test tool, is provided in the receiver head of the ERMO 482X3 PRO barrier. This is a very useful system both for installation and periodical maintenance.

4.1.1 Transmitter Setting-up

To remove the radome unscrew the 6 screws until they turn loose, then release them out gently without remove them completely. Rotate the radome anticlockwise (about 20°) and release it. To close the MW head, fit the radome to it keeping the central logo rotated 20° anticlockwise. Rotate the radome clockwise till the central logo is correctly positioned and then tight the 6 screws.

- Check the a.c. power voltage (19 V~) or d.c. (24 V=) at terminals 1 and 3 on terminal block MS6 (Fig. 9).
- Disconnect the battery and check on the “faston” the d.c. power supply voltage presence (13.6V=).
- Reconnect the “faston” to the battery paying attention to the polarity:
Red wire (terminal 1 of MS5) to positive terminal
Black wire (terminal 2 of MS5) to negative terminal.

Remark: any battery polarity reversal, temporary interrupt the resettable fuse (F3). The equipment will operate properly, after positioning the “faston” correctly.

- Select, one of the 16 modulation channel available, by the hexadecimal switch (within 0 and F). To increase the resistance to tampering actions, it is a good rule to preset different channels for the different barriers installed in the same site. The use of different channel doesn't affect the detection ability of the barrier. By setting up the rotator switch on F Channel, if condition of channel alarm occurs it will not generate any alarm event.

Remark: if one RX receives MW signal from its own transmitter and from another interfering transmitter (for example due to reflections or any other field reason), it is necessary to synchronize the two transmitters, selecting one as Master and the other as Slave. In this case the modulation channel, for the slave transmitter, is the same selected on the Master regardless its own selection.

- It's possible to address each transmitter head in two ways:

1) Local numbering– no change possible from remote.

Assigning (writing) the barrier number:

- Select a number from 1 to 99 on the proper decimal switches SW2 (units) and SW3 (tens). The value 00 means barrier 100.

If decimal switches SW2 (units) and SW3 (tens) should be positioned on 00, for the first time it's necessary to push the button S1 after setting up a barrier number different from 00.

Reading the barrier number:

- It's enough to read the setting up of rotary switches SW2 and SW3.

2) Assigning the barrier number locally, with possibility of changing from remote.

Writing the barrier number:

- Rotate the decimal switch SW2 on position 0, rotate the decimal switch SW3 on position 0.
- Push the button S1.
- Set a new value (from 1 to 99) means of the two switches SW2 (units) and SW3 (tens),
- Close the micro switch "Tamper". In this phase leds of Fault (D8) and Tamper (D9) turn on for 3 seconds, confirming the acquisition of the new value, after that they will turn off for 3 seconds, to go back at their normal functioning. Open up the micro switch "Tamper"

NB: if you wish to prevent possibility of changes from remote of number of barrier number set, push S1 Reset button.

Reading the barrier number:

- Rotate the decimal switch SW2 on position 0, rotate the decimal switch SW3 on position 0.
- Press and then release the S1 reset button,
- Rotate the decimal switch SW2 (units) until the green led D9 becomes on
- Rotate the decimal switch SW3 (tens) until the green led D8 becomes on

The reading values will be included between 01 and 99 and will correspond to the actual barrier number.

NB: in case you should decide NOT to change the number just visualized, it's necessary to close the radome without changing position of decimal switches SW2 and SW3.

- Prepare one of the 16 modulation channels available turning the hexadecimal rotary switch "SW1" in a position between 0 and F. The use of a modulation channel rather than another does not alter the operation of the barrier, however, it is good practice prepare different channels for different barriers of a plant, in order to increase sabotage qualities. By setting the switch on channel F, if the barrier is in channel alarm condition it would not generate the alarm event.

Remark. potentially interfering barriers, due the MW signal of one which can be intercepted on the other (i.e. for installation reasons), it will be necessary to synchronize the transmitters by ensuring that one (Master) provide to the other (slave) the synchronization signal. In this case the modulation frequency of the transmitter slave does not depend on the position of its switch, but only by the synchronization signal.

- Close the radome. To do this operation place the Radome near the back cover, keeping the central logo rotated anticlockwise of 20°. Before to close the head ensure that the tilt switch is vertically positioned. Then fit the front cover to the back cover and rotate it clockwise until the central logo will be correctly positioned and tighten the screws.

4.1.2 Receiver Setting-up

- To remove the radome unscrew the 6 screws until they turn loose, then release them out gently without remove them completely. Rotate the radome anticlockwise (about 20°) and release it. To close the MW head, fit the radome to it keeping the central logo rotated 20° anticlockwise. Rotate the radome clockwise till the central logo is correctly positioned and then tight the 6 screws.
- Check the a.c. power voltage (19 V~) or d.c. (24 V=) at terminals 1 and 3 on terminal block MS4 (Fig. 10).
- Disconnect the battery and check on the “faston” the d.c. power supply voltage presence (13.6Vdc).
- Reconnect the “faston” to the battery paying attention to the polarity:
Red wire (terminal 1 of MS5) to positive terminal
Black wire (terminal 2 of MS5) to negative terminal.

Remark: any battery polarity reversal, temporary interrupt the resettable fuse (F3). The equipment will operate properly, after positioning the “faston” correctly.

- To make the barrier alignment and parameters setting of the barrier using the built in tool, make a preliminary visual mechanical alignment see the following instructions:
 - a. Be sure that the tamper switch is activated (Open circuit)
 - b. Select by the “function switch” **SW1 position 1**. The electronic alignment phase is activated.
 - c. Push S2 button. This action adjust the signal level and freeze, after some seconds, the Automatic Gain Control. In that condition red leds D13 and D12 will be ON and green leds D6, D 7, D8 will be OFF, and the buzzer BZ1 will produce a pulsed sound, this means that the field signal has reached the proper working level.
 - d. Unscrew lightly the bracket screws and move the horizontal alignment of the receiver, looking for the maximum received signal.
 - e. If, during the alignment, one or more green leds become ON means that the received signal level is increased compared with the previous. In this case also the pulse frequency of the sound produced by the on board buzzer, increase. Push again the button S2 and when the green leds become OFF (proper working level), move horizontally in the same direction. If during the movement for the alignment, instead of become ON the green leds, become OFF one or more red leds, and the pulse frequency of the sound produced by the buzzer, decrease, means that the received signal level is decreased compared with the previous, so it is necessary to move back in the other horizontal direction and look for a better received signal. If there is not a new maximum level, means that the present horizontal alignment is the best.
 - f. Unscrew lightly the bracket screws of the transmitter and move the horizontal alignment, looking for the maximum received signal on the receiver head like indicated in the previous point “e”.
 - g. Once the best alignment is reached (maximum signal available), screw strongly the bracket screws, both on transmitter and receiver, to block the horizontal movement.
 - h. Unblock the vertical movement of the receiver and move it slightly upward. Push S3 button and then move the head downward looking for the maximum signal like indicated in the previous point “e”.

- i. Unblock the vertical movement of the transmitter and repeat the operation described for the receiver vertical alignment. Once the best vertical alignment is reached (maximum signal available), block the vertical movement both on transmitter and receiver.
- j. Select by the “function switch” **SW1 position 2**. The acquisition, of the installation values, phase is activated. The installation values are the AGC voltage (V RAG) and the modulation channel number. To complete the phase it is necessary to be sure that nothing change the MW field state (for example the installer himself), then push the button **S2** and wait few seconds. When only the three green leds become ON, the phase is successfully completed. If also the two red leds become ON means that the barrier will works but the signal received was bed (too much noise or something interfering in the MW field). Push again the button S2 been sure that nothing interferes. If only the three red leds become ON the phase is completely aborted, it is necessary to repeat the alignment phase, starting from the previous point “e”, being sure that no obstacles are present in the MW field.

- k. Select by the “function switch” **SW1 position 3**. The **prealarm thresholds** adjusting phase is activated. The two prealarm thresholds are set under and over the rest field value. The analysis process begin when the field value, overcomes one of them. If the field value remain between the prealarm and the alarm threshold continuously for about 40 seconds, a prealarm event is generated and the alarm relay is activated.

To **read** the present prealarm threshold value operate as follow:

- Rotate decimal switch **SW3** (tens column) until the first red led (**D13**) becomes ON.
- Rotate decimal switch **SW2** (units column) until the second red led (**D12**) becomes ON.

The reading values will be included between 05 and 80 (**default value 15**)

Decreasing the threshold value the sensitivity increase like the beam dimension.

To **modify** the present value increasing the sensitivity it is necessary to set, by means of the two switches SW3 and SW2 a lower value and then push the button S2. To decrease the sensitivity, it is necessary to set by means of the two switches SW3 and SW2, a higher value and then push the button S2.

- l. Select by the “function switch” **SW1 position 4**. The **alarm thresholds** adjusting phase and the **walk test** phase are activated. The two alarm thresholds are set under and over the rest field value. They are higher compared with the corresponding prealarm threshold, and are used to evaluate, at the end of the analysis process, if the field value change is enough to generate an alarm event.

To **read** the present alarm threshold value operate as follow:

- Rotate decimal switch **SW3** (tens column) until the first red led (**D13**) becomes ON.
- Rotate decimal switch **SW2** (units column) until the second red led (**D12**) becomes ON.

The reading values will be included between 05 and 80 (**default value 30**)

Decreasing the threshold value the sensitivity increase like the beam dimension.

To **modify** the present value increasing the sensitivity it is necessary to set, by means of the two switches SW3 and SW2, a lower value and then push the button S2. To decrease the sensitivity, it is necessary to set, by means of the two switches SW3 and SW2, a higher value and then push the button **S2**. During this phase (**SW1 position 4**) it is also possible to make the walk test. The barrier works using the present thresholds, and any change in MW field strength received (for example due to an intruder moving in the sensible beam), causes the activation of a pulsed sound produced by the on board buzzer. The pulse frequency is proportional to the level change of the received microwave signal. If the pulse frequency increases it means that, the level change of the received microwave signal, is increased and therefore, it means, that the intruder is penetrated, deeply, in the protection beam. If at the end of the analysis process, an alarm event is generated, the sound of the buzzer become continuous (not pulsed). This allow to check the actual dimension of the protection beam an also to verify if something movable in the protected area, like not well fixed fences, can produce some trouble.

- m. Select by the “function switch” **SW1 position 5**. The **masking thresholds** adjusting phase is activated. The two masking thresholds are set under and over the installation absolute field value (VRAG) memorized during the phase 2 (see previous point j). They are used to check if the changes of the absolute microwave field received are so large to decrease or cancel the detection ability of the barrier. A thick layer of snow can produce this kind of changes, but someone can produce them intentionally, in order to mask the receiver.
To **read** the present masking threshold value operate as follow:
- Rotate decimal switch **SW3** (tens column) until the first red led (**D13**) becomes ON.
 - Rotate decimal switch **SW2** (units column) until the second red led (**D12**) becomes ON.
- The reading values will be included between 05 and 80 (**default value 60**)
Decreasing the threshold value the sensitivity of the anti-masking evaluation increase. To **modify** the present value increasing the sensitivity (smaller changes produce masking alarm) it is necessary to set, by means of the two switches SW3 and SW2, a lower value and then push the button S2. To decrease the sensitivity (bigger changes produce masking alarm), it is necessary to set, by the two switches SW3 and SW2, a higher value and then push the button S2.
- n. Select by the “function switch” **SW1 position 6**. The **higher prealarm threshold** adjusting phase is activated. During the phase k the two prealarm thresholds are positioned at the same value. Increasing the value of the higher prealarm threshold, it is possible to activate the **Fuzzy Side Target Discrimination (FSTD)**, system. This unique system present in ERMO 482X3 PRO barriers, allows to filter or completely reject, signals generated from something moving on both side of protection beam, for example: not well fixed fences or bushes. The resulting beam has an ellipsoidal shape.
To **read** the present higher prealarm threshold value operate as follow:
- Rotate decimal switch **SW3** (tens column) until the first red led (**D13**) becomes ON .
 - Rotate decimal switch **SW2** (units column) until the second red led (**D12**) becomes ON .
- The reading values will be included between 05 and 80 (**default value 15**), and is the same set at point k.
Increasing the higher prealarm threshold value the side sensitivity decrease like the side beam dimension. To decrease the side sensitivity, it is necessary to set by means of the two switches SW3 and SW2, a higher value and then push the button S2.
- o. Select by the “function switch” **SW1 position 7**. The **higher alarm threshold** adjusting phase is activated. As at previous point “n”, to activate the Fuzzy Side Target Discrimination (FSTD) system, it is necessary increase also the higher alarm threshold (generally the same quantity changed in previous point)
To **read** the present higher prealarm threshold value operate as follow:
- Rotate decimal switch **SW3** (tens column) until the first red led (**D13**) becomes ON .
 - Rotate decimal switch **SW2** (units column) until the second red led (**D12**) becomes ON .
- The reading values will be included between 05 and 80 (**default value 30**).
Increasing the higher alarm threshold value the side sensitivity decrease like the side beam dimension. To decrease the side sensitivity, it is necessary to set by means of the two switches SW3 and SW2, a higher value and then push the button S2.
- p. Select by the “function switch” **SW1 position 8**. The **barrier number** setting phase is activated. To communicate by the standard RS 485 serial interface provided on receiver of the ERMO 482X3 PRO barrier, it is possible to select one different barrier number for each receiver installed in the specific site. This allows to communicate through the same bus with the different barriers.

To **read** the present barrier number selected operate as follow:

- Rotate decimal switch **SW3** (tens column) until the first red led (**D13**) becomes ON.
- Rotate decimal switch **SW2** (units column) until the second red led (**D12**) becomes ON.

The reading values will be included between 01 and 99. The value 00 means barrier 100, this is the default value, used when a fatal error occurs and the default parameters are automatically used. To modify the present barrier number it is necessary to set, by means of the two switches SW3 and SW2 a new value and then push the button S2.

- q. Select by the “function switch” **SW1 position 9**. The **monitor threshold** adjusting phase is activated. The two monitor thresholds are set under and over the rest field value. They are necessary to determine the start “save event” phase in the file of the monitor receiver. When one of these two thresholds is exceeded by the variation of the received signal, the recording starts.

To **read** the present monitor threshold value operate as follow:

- Rotate decimal switch **SW3** (tens column) until the first red led (**D13**) becomes ON.
 - Rotate decimal switch **SW2** (units column) until the second red led (**D12**) becomes ON.
- The reading values will be included between 05 and 80 (**default value 15**).

To **modify** the present monitor threshold value operate as follow:

- Rotate decimal switch **SW3** (tens column) and **SW2** (units column) to the desired value
- push the button S2.

- r. Select by the “function switch” **SW1 position A**. The **higher monitor threshold** adjusting phase is activated. Such as the points n. and o., for the correct operation of the "FSTD" system, also the higher monitor threshold must be set to a higher value than that set in step q.

To **read** the present higher monitor threshold value operate as follow:

- Rotate decimal switch **SW3** (tens column) until the first red led (**D13**) becomes ON.
 - Rotate decimal switch **SW2** (units column) until the second red led (**D12**) becomes ON.
- The reading values will be included between 05 and 80 (**default value 15**).

To **modify** the present higher monitor threshold value operate as follow:

- Rotate decimal switch **SW3** (tens column) and **SW2** (units column) to the desired value
- Push the button S2.

- s. Select by the “function switch” **SW1 position B**. The enable/disable standby battery status test phase is activated (paragraph 3.2.2).

To **read** the present standby battery status test value operate as follow:

- Rotate decimal switch **SW3** (tens column) on position 0 (the first red led **D13** becomes ON).
- Rotate decimal switch **SW2** (units column) on position 0 or 1: if the second red led (**D12**) becomes ON at position 0 then the test is disable, otherwise (position 1) the test is active. **Default value 00 (test disable)**.

To **activate** the standby battery status test operate as follow:

- Rotate decimal switch **SW3** (tens column) on position 0
- Rotate decimal switch **SW2** (units column) on position 1
- Push the button S2.

To **disable** the standby battery status test operate as follow:

- Rotate decimal switch **SW3** (tens column) on position 0
- Rotate decimal switch **SW2** (units column) on position 0
- Push the button S2.

- t. Select by the “function switch” **SW1 position C**. The enable/disable “Save Prealarm Event” phase is activated.
To **read** the present “Save Prealarm Event” value operate as follow:
- Rotate decimal switch **SW3** (tens column) on position 0 (the first red led **D13** becomes ON).
 - Rotate decimal switch **SW2** (units column) on position 0 or 1: if the second red led (**D12**) becomes ON at position 0 then the prealarm event will be not saved, otherwise (position 1) the prealarm event will be saved. **Default value 00**.
- To **activate** the “Save Prealarm Event” operate as follow:
- Rotate decimal switch **SW3** (tens column) on position 0
 - Rotate decimal switch **SW2** (units column) on position 1
 - Push the button S2.
- To **disable** the “Save Prealarm Event” operate as follow:
- Rotate decimal switch **SW3** (tens column) on position 0
 - Rotate decimal switch **SW2** (units column) on position 0
 - Push the button S2.
- u. Select by the “function switch” **SW1 position F**. The enable/disable balanced line phase is activated (paragraph 3.3.5).
To **read** the present balanced line value operate as follow:
- Rotate decimal switch **SW3** (tens column) on position 0 (the first red led **D13** becomes ON).
 - Rotate decimal switch **SW2** (units column) on position 0 or 1: if the second red led (**D12**) becomes ON at position 0 then the balanced line is disable, otherwise (position 1) the balanced line is active. **Default value 00 (balanced line disable)**.
- To **activate** the Balanced Line operate as follow:
- Rotate decimal switch **SW3** (tens column) on position 0
 - Rotate decimal switch **SW2** (units column) on position 1
 - Push the button S2.
- To **disable** the Balanced Line operate as follow:
- Rotate decimal switch **SW3** (tens column) on position 0
 - Rotate decimal switch **SW2** (units column) on position 0
 - Push the button S2.
- v. To ensure that all changed parameters are saved and they will be not lost even if you turn off the receiver, Select by the “function switch” **SW1 position 0** and press S2.
- The alignment procedure is closed when the radome will be closed and the tilt switch results in vertical position.

4.2 Adjustment and Testing with Software

Use a PC with **WAVE-TEST2 CIAS** program so as to view and manage all the software parameters of the barrier, including the analogue levels of the thresholds and of the received signal. The connections and/or software functions management procedures are specified in this program's technical documentation.

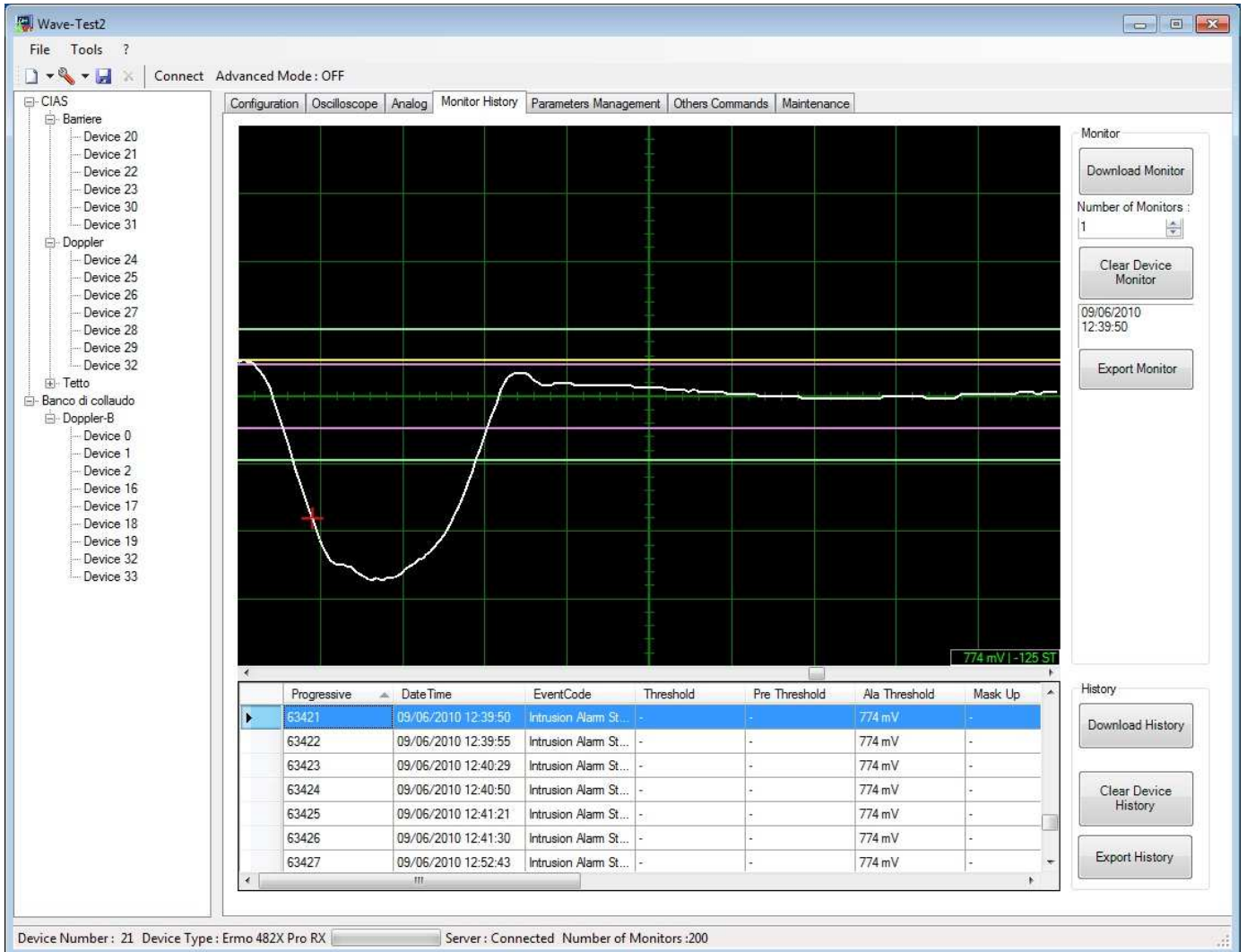

5 MAINTENANCE AND ASSISTANCE

5.1 Troubleshooting

In case of false alarm, check the parameters recorded during the **Installation** phase (on attached **Test Sheet**), if there are divergences with permitted limits check again the related points in chapter "Adjustment and Testing (4)"

Defect	Possible Cause	Possible Solution
Main Power supply LED off Tx and/or Rx	Power Supply 19 V~ or 24V \equiv missing	Check out the Primary and Secondary power supply of the Transformer
	Connections broken	Adjust the connections
	Power Supply circuit broken	Change the Electronic board
Fault Led OFF	Power too high or too low	Check the battery voltage and the power supply
	Temperature too high or too low	Check the temperature of the barrier
	Tx Oscillator Fault	Change the Oscillator
	Tx or Rx failures	Change the Electronic board
Alarm Led OFF	Movement or obstacles in the protected field	Check out that the protected field is free from obstacles and free from objects and/or person moving.
	Barrier not properly aligned	Re do the alignment procedure as described in points: a,b,c,d,e,f,g,h,i of charter 4.1.2
	Wrong channel selections	Do again the Channel acknowledge procedure as described in point j of charter 4.1.2
	Alarm of sensor connected on the balanced line input.	Check out the sensor connected to the balanced line input. If no sensors are connected, disable balanced line. (For TX close JP4, for RX see chapter 4.1.2, point u)
High AGC Voltage	Barrier not properly aligned	Re do the alignment procedure as described in points: a,b,c,d,e,f,g,h,i of charter 4.1.2
	obstacles in the protected field	Remove obstacles
	Too low signal transmitted	Check the transmitter
	Rx circuit fault	Change the Rx circuit
	Rx MW part fault	Change the RX MW part
Tamper Led OFF	Micro switch open	Check the micro switch position
	Tilt bulb in wrong position	Check the position of the tilt bulb
Fault Led Off only on TX circuit	BF Oscillator Fault	Change the TX circuit
	MW oscillator Fault	Change the MW part

5.2 Maintenance kits

The **Maintenance Kits** are composed by circuits equipped with microwave cavities, their substitution is very easy:

Unlock the only one fixing screw and install the new circuit into related plastic guides present on the bottom box.

The circuit and cavity substitution, on both transmitter and receiver heads, doesn't change the heads alignment, and so no new alignment is required.

6 CHARACTERISTICS

6.1 Technical characteristics

TECHNICAL CHARACTERISTICS	Min	Nom	Max	Note
Frequency / PNM:				-
F1 / ERMO482X3PROF1	10,5 GHz		10,6 GHz	
F2 / ERMO482X3PROF2	9,5 GHz		9,975 GHz	
F3 / ERMO482X3PROF3	9,2 GHz		9,5 GHz	
F4 / ERMO482X3PROF4	10,5 GHz	10,525 GHz	10,6 GHz	
F5 / ERMO482X3PROF5	24 GHz		24,25 GHz	
Maximum Power to emitting:				
F1			500 mW	e.i.r.p.
F2			25 mW	e.i.r.p.
F3			25 mW	e.i.r.p.
F4			500 mW	e.i.r.p.
F5			100 mW	e.i.r.p.
Modulation	-	-	-	on/off
Duty-cycle	-	50/50	-	-
Number of channels	-	-	16	-
Range:				
ERMO 482X3 PRO 050	-	50 m	-	-
ERMO 482X3 PRO 080	-	80 m	-	-
ERMO 482X3 PRO 120	-	120 m	-	-
ERMO 482X3 PRO 200	-	200 m	-	-
ERMO 482X3 PRO 250	-	250 m	-	-
ERMO 482X3 PRO 500	-	500 m	-	-
Power supply (V ~)	17 V~	19 V~	21 V~	-
Power supply (V ≡)	11,5 V≡	13,8 V≡	16 V≡	-
Current absorption TX in surveillance (mA ~)	175	183	190	-
Current absorption TX in alarm (mA ~)	130	139	145	-
Current absorption RX in surveillance (mA ~)	130	137	145	-
Current absorption RX in alarm (mA ~)	120	125	130	-
Current absorption TX in surveillance (mA ≡)	80	84	90	-
Current absorption TX in alarm (mA ≡)	60	61	65	-
Current absorption RX in surveillance (mA ≡)	60	63	65	-
Current absorption RX in alarm (mA ≡)	50	56	60	-
Intrusion alarm contact (TX+RX)	-	-	100mA	C-NC
Radome removal contact (TX+RX)	-	-	100mA	C-NC
Fault contact (TX+RX)	-	-	100mA	C-NC
Leds:				
Intrusion alarm (TX+RX) Green LED ON	-	-	-	Not active
Radome removal (TX+RX) Green LED ON	-	-	-	Not active
Fault alarm (TX+RX) Green LED ON	-	-	-	Not active
Threshold adjustment	-	-	-	On board + SW
Housing for battery	-	-	-	12V / 2Ah
Weight without battery (TX)	-	2930 g	-	-
Weight without battery (RX)	-	2990 g	-	-
Diameter	-	-	305 mm	-
Deep, brackets included	-	-	350 mm	-
Working temperature	-35 °C	-	+70 °C	-
Performance level	3°	-	-	-
Box protection level	IP66	-	-	-

6.2 Functional Characteristics

1)	Analysis	Signal processing according to behaviour model.
2)	Analysis	Modulation channel frequency processing (16 channels)
3)	Analysis	Absolute received signal value processing, To guarantee the S/N optimal value (Low level signal).
4)	Analysis	Absolute received signal value processing, for fault detection, behaviour deterioration, masking.
5)	Analysis	Signal trend to select various cases of AGC behaviour.
6)	Analysis	DC Power supply voltage processing (battery charger), High or Low.
7)	Analysis	AC Power supply voltage processing, Presence or Absence.
8)	Analysis	Ambient temperature processing, detection of permitted working range
9)	Analysis	Tampering of Tx and Rx heads.
10)	Availability	Stand-by input control, for monitor adjustment and historical inhibition, living always active the alarm status generation.
11)	Availability	Test input control, to procure on receiver the alarm relay activation in case of positive result.
12)	Availability	Auxiliary balanced line allowing connection of additional sensor. Over two connection conductors between sensor and Tx or Rx head. The capability is to discriminate the following events: alarm, tamper, fault , line cutting, line short circuit
13)	Activation	Three static relay output for alarm, tamper, fault on receiver and transmitter.
14)	Activation	Three signalling LED for alarm, tamper, fault on receiver and transmitter
15)	Activation	Synchronism signal output of transmitter for the other transmitters synchronization
16)	Activation	Synchronism signal input on transmitter for the local transmitter synchronization
17)	Availability	Output terminal block for the battery 12V / 2 Ah connection in case of mains absence.
18)	Availability	16 positions switch for modulation channel frequency choice. During the installation phase the receiver identifies and store automatically which channel must be used during working phase.
19)	Availability	"Supercap" on transmitter and receiver for data storage, also in case of power supply completely OFF
20)	Availability	Calendar watch on transmitter and receiver, for the event storage timing. Both for analogue events monitoring and historical events record.
21)	Availability	Historical event records on transmitter and receiver, for the last 256 events (RX) 128 (TX) occurred, with the value (if any), data, time and event types indication. The data acquisition can be done with WAVE-TEST2 software, the data will be stored in historical files (for read and print).
22)	Availability	Up to 100 event records (2.5 seconds each) stored in receiver memory, related to detected analogue signal if higher then user preset value (called monitor threshold).
23)	Availability	A default parameters set, for transmitter and receiver, to use whenever absent or if the self diagnosis detects a wrong parameter.
24)	Availability	connector on transmitter and receiver, for external measures
25)	Availability	P. C. connector on transmitter and receiver, for serial line RS485 connection, used with software WAVE-TEST2 for tests, settings and management of barrier.



TEST SHEET

ERMO 482X3 PRO TX

SERIAL NUMBER: _____

Customer _____

Address _____

Barrier N° _____

MEASURED VALUES ON THE TRASMITTER

MEASUREMENTS		STANDARD VALUES	MEASURED VALUES	
			INSTALLATION	MAINTENANCE
1	SUPPLY VOLTAGE, MEASURED BETWEEN PINS 1-2 OF MS5 WITH BATTERY DISCONNECTED. (*)	13,6 VDC ± 10%		
2	MASTER/SLAVE SELECTION	-	<input type="checkbox"/> MASTER <input type="checkbox"/> SLAVE	<input type="checkbox"/> MASTER <input type="checkbox"/> SLAVE
3	MODULATION CHANNEL SELECTED	-	<input type="checkbox"/> Ch 0 <input type="checkbox"/> Ch 8 <input type="checkbox"/> Ch 1 <input type="checkbox"/> Ch 9 <input type="checkbox"/> Ch 2 <input type="checkbox"/> Ch A <input type="checkbox"/> Ch 3 <input type="checkbox"/> Ch B <input type="checkbox"/> Ch 4 <input type="checkbox"/> Ch C <input type="checkbox"/> Ch 5 <input type="checkbox"/> Ch D <input type="checkbox"/> Ch 6 <input type="checkbox"/> Ch E <input type="checkbox"/> Ch 7 <input type="checkbox"/> Ch F	<input type="checkbox"/> Ch 0 <input type="checkbox"/> Ch 8 <input type="checkbox"/> Ch 1 <input type="checkbox"/> Ch 9 <input type="checkbox"/> Ch 2 <input type="checkbox"/> Ch A <input type="checkbox"/> Ch 3 <input type="checkbox"/> Ch B <input type="checkbox"/> Ch 4 <input type="checkbox"/> Ch C <input type="checkbox"/> Ch 5 <input type="checkbox"/> Ch D <input type="checkbox"/> Ch 6 <input type="checkbox"/> Ch E <input type="checkbox"/> Ch 7 <input type="checkbox"/> Ch F

(*) It is possible to make the measure also by the STC 95

INSTALLER COMMENTS

Installation date _____

Installer Signature _____

CUT HERE



TEST SHEET

ERMO 482X3 PRO RX

SERIAL NUMBER: _____

Customer _____

Address _____

Barrier N° _____

MEASURED VALUES ON THE RECEIVER

MEASUREMENTS		STANDARD VALUES	MEASURED VALUES	
			INSTALLATION	MAINTENANCE
1	SUPPLY VOLTAGE, MEASURED BETWEEN PINS 1-2 OF MS5 WITH BATTERY DISCONNECTED. (*)	13,6 VDC ± 10%		
2	AGC VOLTAGE MEASURED BETWEEN PIN 14 OF J3 AND GND. (*)	1,5 ÷ 5 VDC		
3	MODULATION CHANNEL USED	-	<input type="checkbox"/> Ch 0 <input type="checkbox"/> Ch 8 <input type="checkbox"/> Ch 1 <input type="checkbox"/> Ch 9 <input type="checkbox"/> Ch 2 <input type="checkbox"/> Ch A <input type="checkbox"/> Ch 3 <input type="checkbox"/> Ch B <input type="checkbox"/> Ch 4 <input type="checkbox"/> Ch C <input type="checkbox"/> Ch 5 <input type="checkbox"/> Ch D <input type="checkbox"/> Ch 6 <input type="checkbox"/> Ch E <input type="checkbox"/> Ch 7 <input type="checkbox"/> Ch F	<input type="checkbox"/> Ch 0 <input type="checkbox"/> Ch 8 <input type="checkbox"/> Ch 1 <input type="checkbox"/> Ch 9 <input type="checkbox"/> Ch 2 <input type="checkbox"/> Ch A <input type="checkbox"/> Ch 3 <input type="checkbox"/> Ch B <input type="checkbox"/> Ch 4 <input type="checkbox"/> Ch C <input type="checkbox"/> Ch 5 <input type="checkbox"/> Ch D <input type="checkbox"/> Ch 6 <input type="checkbox"/> Ch E <input type="checkbox"/> Ch 7 <input type="checkbox"/> Ch F

(*) It is possible to make the measure also by the STC 95

INSTALLER COMMENTS

Installation date _____

Installer Signature _____

CUT HERE



This device complies with Part 15 of the FCC Rules [and with Industry Canada licence-exempt RSS standard(s)].

Operation is subject to the following two conditions.

- (1) This device may not cause harmful interference, and*
- (2) This device must accept any interference received, including interference that may cause undesired operation.*

Le présent appareil est conforme aux CNR d'Industrie Canada applicables aux appareils radio exempts de licence. L'exploitation est autorisée aux deux conditions suivantes:

- (1) l'appareil ne doit pas produire de brouillage, et*
- (2) l'utilisateur de l'appareil doit accepter tout brouillage radioélectrique subi, même si le brouillage est susceptible d'en compromettre le fonctionnement.*

NOTICE: *Changes or modifications made to this equipment not expressly approved by **CIAS Elettronica** may void the FCC authorization to operate this equipment.*

NOTE: *This equipment has been tested and found to comply with the limits for a Class B digital device, pursuant to Part 15 of the FCC Rules. These limits are designed to provide reasonable protection against harmful interference in a residential installation. This equipment generates, uses and can radiate radio frequency energy and, if not installed and used in accordance with the instructions, may cause harmful interference to radio communications. However, there is no guarantee that interference will not occur in a particular installation. If this equipment does cause harmful interference to radio or television reception, which can be determined by turning the equipment off and on, the user is encouraged to try to correct the interference by one or more of the following measures:*

- Reorient or relocate the receiving antenna.*
- Increase the separation between the equipment and receiver.*
- Connect the equipment into an outlet on a circuit different from that to which the receiver is connected.*
- Consult the dealer or an experienced radio/TV technician for help.*

IMPORTANT NOTE:

Radiofrequency radiation exposure Information:

This equipment complies with FCC radiation exposure limits set forth for an uncontrolled environment. This equipment should be installed and operated with minimum distance of 20 cm between the radiator and your body.

This transmitter must not be co-located or operating in conjunction with any other antenna or transmitter.

© Copyright CIAS Elettronica S.r.l.

Stampato in Italia / Printed in Italy

CIAS Elettronica S.r.l.

Direzione, Ufficio Amministrativo, Ufficio Commerciale, Laboratorio di Ricerca e Sviluppo

Direction, Administrative Office, Sales Office, Research and Development Laboratory

20158 Milano, via Durando n. 38

Tel. +39 02 376716.1

Fax +39 02 39311225

Web-site: www.cias.it

E-mail: info@cias.it

Stabilimento / Factory

23887 Olgiate Molgora (LC), Via Don Sturzo n. 17