

---

## **Document Title**

A7130 Data Sheet, 2.4GHz FSK/GFSK Transceiver with 4Mbps data rate

## **Revision History**

<b><u>Rev. No.</u></b>	<b><u>History</u></b>	<b><u>Issue Date</u></b>	<b><u>Remark</u></b>
0.0	Initial issue.	Dec, 2009	Objective
0.1	Update ch8 and the application circuit.	July, 2011	Preliminary,
0.2	Modify the tape reel information and the add Shenzhen office address.	July, 2011	Preliminary,
0.3	Add Ch20 WOR and Ch21 AES128.	Aug., 2011	Preliminary,
0.4	Add section 16.4.3 FIFO extension and Ch21 AES128. Update sleep current, Xtal start up time and PDL formula, TMOE timing, WTR Timing, and Ch14.	Apr., 2012	Preliminary,,
0.5	Remove 3Mbps data rate Add descriptions for HECF, FECF and CRCF clear method in 9.2.1	Aug.,2012	Preliminary
0.6	Add suggestion in WOR function	Oct. 2012	Preliminary

AMICCOM CONFIDENTIAL

### **Important Notice:**

AMICCOM reserves the right to make changes to its products or to discontinue any integrated circuit product or service without notice. AMICCOM integrated circuit products are not designed, intended, authorized, or warranted to be suitable for use in life-support applications, devices or systems or other critical applications. Use of AMICCOM products in such applications is understood to be fully at the risk of the customer.

**Table of Contents**

1. General Description..... 5

2. Typical Applications ..... 5

3. Feature ..... 5

4. Pin Configurations ..... 6

5. Pin Description (I: input; O: output, I/O: input or output)..... 7

6. Chip Block Diagram..... 8

7. Absolute Maximum Ratings..... 9

8. Electrical Specification ..... 10

9. Control Register ..... 12

    9.1 Control register table..... 12

    9.2 Control register description ..... 15

        9.2.1 Mode Register (Address: 00h)..... 15

        9.2.2 Mode Control Register (Address: 01h)..... 15

        9.2.3 Calibration Control Register (Address: 02h)..... 16

        9.2.4 FIFO Register I (Address: 03h)..... 16

        9.2.5 FIFO Register II (Address: 04h)..... 16

        9.2.6 FIFO DATA Register (Address: 05h)..... 16

        9.2.7 ID DATA Register (Address: 06h)..... 16

        9.2.8 RC OSC Register I (Address: 07h)..... 17

        9.2.9 RC OSC Register II (Address: 08h)..... 17

        9.2.10 RC OSC Register III (Address: 09h)..... 17

        9.2.11 CKO Pin Control Register (Address: 0Ah)..... 17

        9.2.12 GIO1 Pin Control Register I (Address: 0Bh)..... 18

        9.2.13 GIO2 Pin Control Register II (Address: 0Ch)..... 20

        9.2.14 Clock Register (Address: 0Dh)..... 21

        9.2.15 PLL Register I (Address: 0Eh)..... 21

        9.2.16 PLL Register II (Address: 0Fh)..... 21

        9.2.17 PLL Register III (Address: 10h)..... 22

        9.2.18 PLL Register IV (Address: 11h)..... 22

        9.2.19 PLL Register V (Address: 12h)..... 22

        9.2.20 Channel Group Register I (Address: 13h)..... 22

        9.2.21 Channel Group Register II (Address: 14h)..... 22

        9.2.22 TX Register I (Address: 15h)..... 23

        9.2.23 TX Register II (Address: 16h)..... 23

        9.2.24 Delay Register I (Address: 17h)..... 23

        9.2.25 Delay Register II (Address: 18h)..... 24

        9.2.26 RX Register (Address: 19h)..... 24

        9.2.27 RX Gain Register I (Address: 1Ah)..... 25

        9.2.28 RX Gain Register II (Address: 1Bh)..... 25

        9.2.29 RX Gain Register III (Address: 1Ch)..... 25

        9.2.30 RX Gain Register IV (Address: 1Dh)..... 26

        9.2.31 RSSI Threshold Register (Address: 1Eh)..... 26

        9.2.32 ADC Control Register (Address: 1Fh)..... 26

        9.2.33 Code Register I (Address: 20h)..... 26

        9.2.34 Code Register II (Address: 21h)..... 27

        9.2.35 Code Register III (Address: 22h)..... 27

        9.2.36 IF Calibration Register I (Address: 23h)..... 27

        9.2.37 IF Calibration Register II (Address: 24h)..... 28

        9.2.38 VCO current Calibration Register (Address: 25h)..... 28

        9.2.39 VCO band Calibration Register I (Address: 26h)..... 28

        9.2.40 VCO band Calibration Register II (Address: 27h)..... 29

        9.2.41 VCO Deviation Calibration Register I (Address: 28h)..... 29

        9.2.42 VCO Deviation Calibration Register II (Address: 29h)..... 29

        9.2.43 DASP0 (Address: 2Ah, Page 0 by AGT[3:0]=0)..... 30

        9.2.43 DASP1 (Address: 2Ah, Page 1 by AGT[3:0]=1)..... 30

9.2.43 DASP2 (Address: 2Ah, Page 2 by AGT[3:0]=2)	30
9.2.43 DASP3 (Address: 2Ah, Page 3 by AGT[3:0]=3)	31
9.2.43 DASP4 (Address: 2Ah, Page 4 by AGT[3:0]=4)	31
9.2.43 DASP5 (Address: 2Ah, Page 5 by AGT[3:0]=5)	31
9.2.43 DASP6 (Address: 2Ah, Page 6 by AGT[3:0]=6)	31
9.2.43 DASP7 (Address: 2Ah, Page 7 by AGT[3:0]=7)	31
9.2.44 VCO Modulation Delay Register (Address: 2Bh)	31
9.2.45 Battery detect Register (Address: 2Ch)	32
9.2.46 TX test Register (Address: 2Dh)	32
9.2.47 Rx DEM test Register I (Address: 2Eh)	32
9.2.48 Rx DEM test Register II (Address: 2Fh)	33
9.2.49 Charge Pump Current Register I (Address: 30h)	33
9.2.50 Charge Pump Current Register II (Address: 31h)	33
9.2.51 Crystal test Register (Address: 32h)	33
9.2.52 PLL test Register (Address:33h)	34
9.2.53 VCO test Register I (Address:34h)	34
9.2.54 RF Analog Test Register (Address: 35h)	34
9.2.55 AES Key data Register (Address: 36h)	35
9.2.56 Channel Select Register (Address: 37h)	35
9.2.57 ROMP0 (Address: 38h, Page 0 by AGT[3:0]=0)	35
9.2.57 ROMP1 (Address: 38h, Page 1 by AGT[3:0]=1)	35
9.2.57 ROMP2 (Address: 38h, Page 2 by AGT[3:0]=2)	36
9.2.57 ROMP3 (Address: 38h, Page 3 by AGT[3:0]=3)	36
9.2.57 ROMP4 (Address: 38h, Page 4 by AGT[3:0]=4)	36
9.2.58 Data Rate Clock Register (Address: 39h)	36
9.2.59 FCR Register (Address: 3Ah)	36
9.2.60 ARD Register (Address: 3Bh)	37
9.2.61 AFEP Register (Address: 3Ch)	37
9.2.62 FCB Register (Address: 3Dh)	37
9.2.63 KEYC Register (Address: 3Eh)	38
9.2.64 USID Register (Address: 3Fh)	38
10. SPI	39
10.1 SPI Format	40
10.2 SPI Timing Characteristic	40
10.3 SPI Timing Chart	41
10.3.1 Timing Chart of 3-wire SPI	41
10.3.2 Timing Chart of 4-wire SPI	41
10.4 Strobe Commands	42
10.4.1 Strobe Command - Sleep Mode	42
10.4.2 Strobe Command - Idle Mode	42
10.4.3 Strobe Command - Standby Mode	43
10.4.4 Strobe Command - PLL Mode	43
10.4.5 Strobe Command - RX Mode	44
10.4.6 Strobe Command - TX Mode	44
10.4.7 Strobe Command – FIFO Write Pointer Reset	44
10.4.8 Strobe Command – FIFO Read Pointer Reset	45
10.4.9 Strobe Command – Deep Sleep Mode	45
10.5 Reset Command	46
10.6 ID Accessing Command	46
10.6.1 ID Write Command	46
10.6.2 ID Read Command	47
10.7 FIFO Accessing Command	47
10.7.1 TX FIFO Write Command	47
10.7.2 Rx FIFO Read Command	48
11. State machine	49
11.1 Key states	49
11.2 FIFO mode	50
11.3 Direct mode	51
12. Crystal Oscillator	54
12.1 Use External Crystal	54

12.2 Use External Clock .....	54
13. System Clock .....	55
13.2 Data Rate Setting .....	55
14. Transceiver LO Frequency .....	56
14.1 LO Frequency Setting .....	56
14.2 IF Side Band Select .....	57
14.2.1 Auto IF Exchange .....	58
14.2.2 Fast Exchange .....	59
14.3 Auto Frequency Compensation .....	60
15. Calibration .....	60
15.1 Calibration Procedure .....	60
16. FIFO (First In First Out) .....	61
16.1 TX Packet Format in FIFO mode .....	61
16.1.1 Basic FIFO mode .....	61
16.1.2 Advanced FIFO mode .....	61
16.2 Bit Stream Process in FIFO mode .....	62
16.3 Transmission Time .....	63
16.4 Usage of TX and RX FIFO .....	63
16.4.1 Easy FIFO .....	64
16.4.2 Segment FIFO .....	65
16.4.3 FIFO Extension .....	67
17. ADC (Analog to Digital Converter) .....	71
17.1 RSSI Measurement .....	71
18. Battery Detect .....	73
19. Auto-ack and auto-resend .....	74
19.1 Basic FIFO plus auto-ack auto-resend .....	74
19.2 Advanced FIFO plus auto-ack and auto-resend .....	74
19.3 WTR Behavior during auto-ack and auto-resend .....	76
19.6 Examples of auto-ack and auto-resend .....	77
20. RC Oscillator .....	79
20.1 WOR Function .....	79
20.2 TWOR Function .....	80
21. AES128 Security Packet .....	80
22. Application circuit .....	81
22.1 MD7130-A01 .....	81
22.2 MD7130-F07 .....	82
23. Abbreviations .....	83
24. Ordering Information .....	83
25. Package Information .....	84
26. Top Marking Information .....	85
27. Reflow Profile .....	86
28. Tape Reel Information .....	87
29. Product Status .....	89

## 1. General Description

A7130 is a high performance and low cost 2.4GHz ISM band wireless transceiver. This device integrates both high sensitivity receiver (-88dBm @4Mbps) and programmable power amplifier 5dBm. Based on Data Rate Register (39h), user can configure on-air data rates to 4Mbps.

A7130 supports fast settling time (90 us) for frequency hopping system. For packet handling, A7130 has built-in separated 64-bytes TX/RX FIFO (could be logically extended to 4K bytes) for data buffering and burst transmission, auto-ack and auto-resend, CRC for error packet filtering, FEC for 1-bit data correction per code word, RSSI for clear channel assessment, thermal sensor for monitoring relative temperature, WOR (Wake on RX) function to support periodically wake up from sleep mode to RX mode and listen for incoming packets without MCU interaction, data whitening for data encryption / decryption. In addition, A7130 has built-in AES128 co-processor (Advanced Encryption Standard) for advanced data encryption and decryption which consists of the transformation of a 128-bit block into an encrypted 128-bit block. Those functions are very easy to use while developing a wireless system. All features are integrated in a small QFN 4X4 20 pins package.

A7130's **control registers** are accessed via 3-wire or 4-wire SPI interfaces such as TX/RF FIFO, ID register, RSSI value, frequency hopping to chip calibration procedures. Another one, via SPI as well, is the unique **Strobe command**, A7130 can be controlled from power saving mode (deep sleep, sleep, idle, standby), PLL mode, TX mode and RX mode. The other connections between A7130 and MCU are GIO1 and GIO2 (multi-function GPIO) to output A7130's status so that MCU could use either polling or interrupt scheme for radio control. Overall, this device is very easy-to-use for developing a wireless application with a MCU.

## 2. Typical Applications

- 2.4GHz video baby monitor
- 2.4GHz PC peripherals
- HiFi quality wireless audio streaming
- 2408 ~ 2468 MHz ISM system
- Wireless metering and building automation
- Wireless toys and game controllers

## 3. Feature

- Small size (QFN4 X4, 20 pins).
- Frequency band: 2408 ~ 2468MHz.
- FSK or GFSK modulation
- Low current consumption: RX 27mA (4Mbps), TX 29mA (at 5dBm output power).
- Deep sleep current (0.1 uA).
- Sleep current (2.5 uA).
- On chip regulator, support input voltage 2.0 ~ 3.6 V.
- Data rate 4Mbps.
- Programmable TX power level from 5 dBm.
- Ultra High sensitivity:
  - ◆ -88dBm at 4Mbps on-air data rate.
- Fast settling time (90 us) synthesizer for frequency hopping system.
- On chip low power RC oscillator for WOR (Wake on RX) function.
- Built-in AES128 co-processor
- AGC (Auto Gain Control) for the wide RSSI dynamic range.
- AFC (Auto Frequency Compensation) for frequency drift due to temperature.
- Support low cost crystal (16 / 18 MHz).
- Low Battery Detector indication.
- Easy to use.
  - ◆ Support 3-wire or 4-wire SPI.
  - ◆ Unique Strobe command via SPI.
  - ◆ ONE register setting for new channel frequency.
  - ◆ CRC Error Packet Filtering.
  - ◆ Auto-acknowledgement and auto-resend.
  - ◆ Dynamic FIFO length.
  - ◆ 8-bits RSSI measurement for clear channel indication.
  - ◆ Auto Calibrations.

- ◆ Auto IF function.
- ◆ Auto FEC by (7, 4) Hamming code (1 bit error correction / code word).
- ◆ Separated 64 bytes RX and TX FIFO.
- ◆ Easy FIFO / Segment FIFO / FIFO Extension (up to 4K bytes).
- ◆ Support FIFO mode frame sync to MCU.
- ◆ Support direct mode with recovery clock output to MCU.

## 4. Pin Configurations

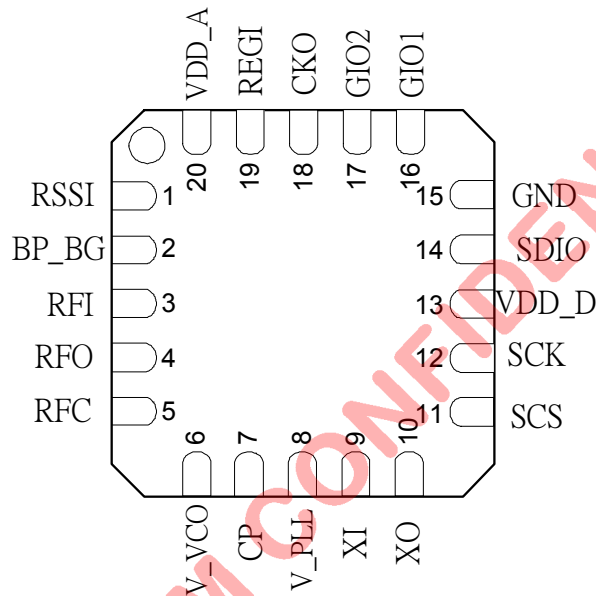

Fig 4-1. A7130 QFN 4x4 Package Top View

**5. Pin Description (I: input; O: output, I/O: input or output)**

Pin No.	Symbol	I/O	Function Description
1	RSSI	O	Connected to a bypass capacitor for RSSI.
2	BP_BG	O	Connected to a bypass capacitor for internal Regulator bias point.
3	RFI	I	LNA input. Connected to matching circuit.
4	RFO	O	PA input. Connected to matching circuit.
5	RFC	I	RF Choke input. Connected to matching circuit.
6	V_VCO	I	VCO supply voltage input.
7	CP	O	Charge-pump. Connected to loop filter.
8	V_PLL	I	PLL supply voltage input.
9	XI	I	Crystal oscillator input.
10	XO	O	Crystal oscillator output.
11	SCS	I	SPI chip select.
12	SCK	I	SPI clock input pin.
13	VDD_D	I	Connected to a bypass capacitor to supply voltage for digital part.
14	SDIO	I/O	SPI read/write data.
15	GND	G G	round
16	GIO1	I/O	Multi-function GIO1 / 4-wire SPI data output.
17	GIO2	I/O	Multi-function GIO2 / 4-wire SPI data output.
18	CKO	O	Multi-function clock output.
19	REGI	I	Regulator input ( <b>External Power Input</b> )
20	VDD_A	O	Internal Regulator output to supply V_VCO (pin 6), V_PLL (pin 8) and RFC (pin 5).
	<b>Back side plate</b>	G	Ground. Back side plate shall be well-solder to ground; otherwise, it will impact RF performance.

**6. Chip Block Diagram**

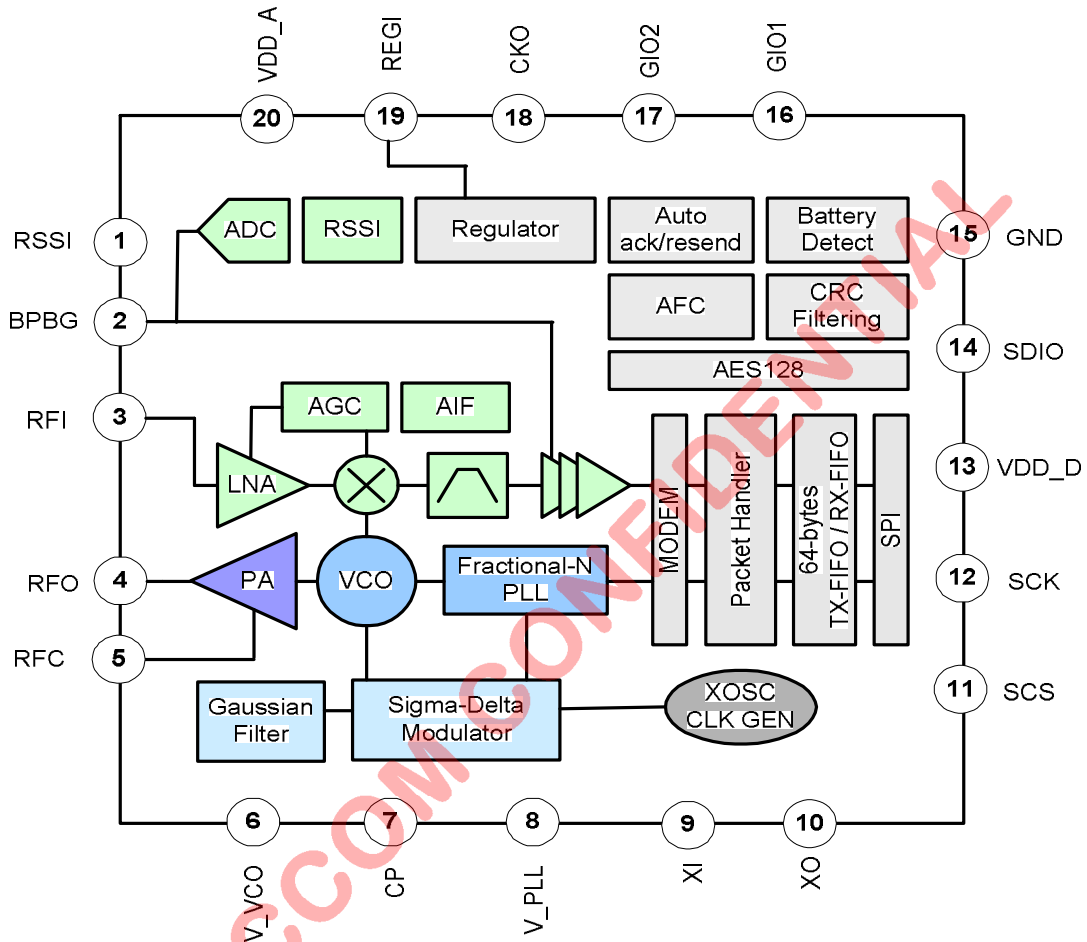

Fig 6-1. A7130 Block Diagram



**7. Absolute Maximum Ratings**

Parameter	With respect to	Rating	Unit
Supply voltage range (VDD)	GND	-0.3 ~ 3.6	V
Digital IO pins range	GND	-0.3 ~ VDD+0.3	V
Voltage on the analog pins range	GND	-0.3 ~ 2.1	V
Input RF level		10	dBm
Storage Temperature range		-55 ~ 125	°C
ESD Rating	HBM	± 2K	V
	MM	± 100	V

\*Stresses above those listed under "Absolute Maximum Rating" may cause permanent damage to the device. These are stress ratings only; functional operation of the device at these or any other conditions above those indicated in the operational sections of this specification is not implied. Exposure to absolute-maximum-rated conditions for extended periods may affect device reliability.

\*Device is ESD sensitive. Use appropriate ESD precautions. HBM (Human Body Mode) is tested under MIL-STD-883F Method 3015.7. MM (Machine Mode) is tested under JEDEC EIA/JESD22-A115-A.

\*Device is Moisture Sensitivity Level III (MSL 3).



AMICCOM CONFIDENTIAL

## 8. Electrical Specification

(Ta=25°C, VDD=3.3V, FXTAL =16MHz, with Match circuit and low pass filter, On Chip Regulator = 1.8V, unless otherwise noted.)

Parameter	Description	Min.	Type	Max.	Unit
<b>General</b>					
Operating Temperature		-40		85	°C
Supply Voltage (VDD)	with internal regulator	2.0	3.3	3.6	V
Current Consumption	Deep Sleep mode* <sup>1</sup> (No registers retention)		0.1		μA
Current Consumption (DBL =0 at 0Fh, bit7)	Sleep mode (WOR off) * <sup>1</sup>		2.5		μA
	Sleep mode (WOR on) * <sup>1</sup>		3.5		μA
	Idle Mode (Regulator on) * <sup>1</sup>		0.3		mA
	Standby Mode (XOSC on, CLK Gen. on)		2.7		mA
	PLL mode		12.5		mA
	RX Mode (4Mbps)		27		mA
	TX Mode (5dBm)		29		mA
	TX Mode (3dBm)		24		mA
	TX Mode (0dBm)		20		mA
	TX Mode ( -5dBm)		18		mA
TX Mode ( -17dBm)		16		mA	
<b>PLL block</b>					
Crystal start up time* <sup>2</sup> (3225 SMD type)	Idle to standby (Xtal osc. is stable at 20ppm)		1		ms
	Idle to standby (Xtal osc. is stable at 10ppm)		2		ms
Crystal frequency	Data rate: 4Mbps		16		MHz
Crystal tolerance	Data rate: 4M/bps		±50		ppm
Crystal ESR				80	ohm
VCO Operation Frequency		2408		2468	MHz
PLL phase noise	Offset 10k		75		dBc
	Offset 500K		90		
	Offset 1M		100		
PLL settling time* <sup>3</sup>	Loop filter based on app. circuit. (Standby to PLL)		30		μS
<b>Transmitter</b>					
Output power range		-17	0	5	dBm
Out Band Spurious Emission * <sup>4</sup>	30MHz~1GHz			-36	dBm
	1GHz~12.75GHz			-30	dBm
	1.8GHz~ 1.9GHz			-47	dBm
	5.15GHz~ 5.3GHz			-47	dBm
Frequency deviation* <sup>5</sup>	Data rate 4Mbps		±1M		Hz
Data rate			4M		bps
TX ready time* <sup>6</sup>	Standby to TX		90		μS
<b>Receiver</b>					
Receiver sensitivity @ BER = 0.1%	Data rate 4Mbps		-88		dBm
	Data rate 4Mbps (GFSK)		-85		

IF Filter bandwidth	IFS = [11], 4Mbps		4.8M		Hz
IF center frequency	IFS = [11], 4Mbps		4M		Hz
Interference *7 (4Mbps , IF = 4MHz)	Co-Channel (C/I <sub>0</sub> )		11		dB
	±4MHz Adjacent Channel		0		dB
	±8MHz Adjacent Channel		- 10		dB
	±12MHz Adjacent Channel		- 20		dB
	±16MHz Adjacent Channel		- 30		dB
	Image (C/I <sub>IM</sub> )		- 10		dB
Maximum Operating Input Power	@RF input (BER=0.1%)			5	dBm
RX Spurious Emission *4	30MHz~1GHz			-57	dBm
	1GHz~12.75GHz			-47	
RSSI Range	AGC = 0	-95		-50	dBm
	AGC = 1	-95		-20	dBm
RX Ready Time			80		μs
<b>Regulator</b>					
Regulator settling time	Pin 2 connected to 470pF. (Sleep to idle).		0.5		ms
Band-gap reference voltage			1.28		V
Regulator output voltage		1.79	1.8	2.3	V
<b>Digital IO DC characteristics</b>					
High Level Input Voltage (V <sub>IH</sub> )		0.8*VDD		VDD	V
Low Level Input Voltage (V <sub>IL</sub> )		0		0.2*VDD	V
High Level Output Voltage (V <sub>OH</sub> )	@I <sub>OH</sub> = -0.5mA	VDD-0.4		VDD	V
Low Level Output Voltage (V <sub>OL</sub> )	@I <sub>OL</sub> = 0.5mA	0		0.4	V

- Note 1: When digital I/O pins are configured as input, those pins shall NOT be floating but pull either high or low (SCS shall be pulled high only); otherwise, leakage current will be induced.
- Note 2: Xtal settling time is depend on Xtal package type, Xtal ESR and Xtal Cm.
- Note 3: Refer to Delay Register I (17h) to set PDL (PLL settling delay).
- Note 4: With external RF filter that provides minimum 17dB of attenuation in the band: 30MHz ~ 2GHz and 3GHz ~12.75GHz.
- Note 5: Refer to TX Register II (16h) to set FD [7:0].
- Note 6: Refer to Delay Register I (17h) to set PDL and TDL.
- Note 7: The wanted signal is set above sensitivity level +3dB. The modulation data of wanted signal and interferer are PN9 and PN15, respectively.

## 9. Control Register

A7130 contains 69 control registers. MCU can access those control registers via 3-wire (SCS, SCK, SDIO) or 4-wire (SCS, SCK, SDIO, GIO1/GIO2) SPI interface (max. 15 Mbps). Please refer to Chapter 10 for SPI timing. In general, most of control registers are just need to configure the recommended values based on A7130 reference code.

### 9.1 Control register table

Address / Name	R/W	Bit 7	Bit 6	Bit 5	Bit 4	Bit 3	Bit 2	Bit 1	Bit 0
00h Mode	W	RESETN	RESETN	RESETN	RESETN	RESETN	RESETN	RESETN	RESETN
	R	HECF	FECF	CRCF	CER	XER	PLLER	TRSR	TRER
01h Mode control	W	DDPC	ARSSI	AIF	DFCD	WORE	FMT	FMS	ADCM
	R	DDPC	ARSSI	AIF	CD	WORE	FMT	FMS	ADCM
02h Calc	R/W	--	--	--	VCC	VBC	VDC	FBC	RSSC
03h FIFO I	W	--	--	--	--	FEP11	FEP10	FEP9	FEP8
	R	--	--	--	--	LENF11	LENF10	LENF9	LENF8
	W	FEP7	FEP6	FEP5	FEP4	FEP3	FEP2	FEP1	FEP0
	R	LENF7	LENF6	LENF5	LENF4	LENF3	LENF2	LENF1	LENF0
04h FIFO II	W	FPM1	FPM0	PSA5	PSA4	PSA3	PSA2	PSA1	PSA0
05h FIFO Data	R/W	FIFO7	FIFO6	FIFO5	FIFO4	FIFO3	FIFO2	FIFO1	FIFO0
06h ID Data	R/W	ID7	ID6	ID5	ID4	ID3	ID2	ID1	ID0
07h RC OSC I	W	WOR_SL7	WOR_SL6	WOR_SL5	WOR_SL4	WOR_SL3	WOR_SL2	WOR_SL1	WOR_SL0
	R	RCOC7	RCOC6	RCOC5	RCOC4	RCOC3	RCOC2	RCOC1	RCOC0
08h RC OSC II	W	WOR_SL9	WOR_SL8	WOR_AC5	WOR_AC4	WOR_AC3	WOR_AC2	WOR_AC1	WOR_AC0
09h RC OSC III	W	RTCS	RCOT2	RCOT1/ RTCC1	RCOT0/ RTCC0	CALWC	RCOSC_E	TSEL	TWORE
	R	--	--	--	--	CALWR	--	--	--
0Ah CKO Pin	W	ECKOE	CKOS3	CKOS2	CKOS1	CKOS0	CKOI	CKOE	SCKI
0Bh GPIO1 Pin I	W	VKM	VPM	GIO1S3	GIO1S2	GIO1S1	GIO1S0	GIO1I	GIO1OE
0Ch GPIO2 Pin II	W	BBCKS1	BBCKS0	GIO2S3	GIO2S2	GIO2S1	GIO2S0	GIO2I	GIO2OE
0Dh Clock	W	CGC1	CGC0	GRC3	GRC2	GRC1	GRC0	CGS	XS
	R	IFS1	IFS0	GRC3	GRC2	GRC1	GRC0	--	--
0Eh PLL I	R/W	CHN7	CHN6	CHN5	CHN4	CHN3	CHN2	CHN1	CHN0
0Fh PLL II	W	DBL	RRC1	RRC0	CHR3	CHR2	CHR1	CHR0	BIP8
	R	DBL	RRC1	RRC0	CHR3	CHR2	CHR1	CHR0	IP8
10h PLL III	W	BIP7	BIP6	BIP5	BIP4	BIP3	BIP2	BIP1	BIP0
	R	IP7	IP6	IP5	IP4	IP3	IP2	IP1	IP0
11h PLL IV	W	BFP15	BFP14	BFP13	BFP12	BFP11	BFP10	BFP9	BFP8
	R FS	YN-FP15	AC14-FP14	AC13-FP13	AC12-FP12	AC11-FP11	AC10-FP10	AC9-FP9	AC8-FP8
12h PLL V	W	BFP7	BFP6	BFP5	BFP4	BFP3	BFP2	BFP1	BFP0
	R	AC7-FP7	AC6-FP6	AC5-FP5	AC4-FP4	AC3-FP3	AC2-FP2	AC1-FP1	AC0-FP0
13h Channel Group I	R/W	CHGL7	CHGL6	CHGL5	CHGL4	CHGL3	CHGL2	CHGL1	CHGL0
14h Channel Group II	R/W	CHGH7	CHGH6	CHGH5	CHGH4	CHGH3	CHGH2	CHGH1	CHGH0
15h TX I	W	GDR	GF	TMDE	TXDI	TME	FDP2	FDP1	FDP0

16h TX II	W	FD7	FD6	FD5	FD4	FD3	FD2	FD1	FD0
17h Delay I	W	DPR2	DPR1	DPR0	TDL1	TDL0	PDL2	PDL1	PDL0
18h Delay II	W	WSEL2	WSEL1	WSEL0	RSSC_D1	RSSC_D0	RS_DLY2	RS_DLY1	RS_DLY0
19h RX	W	LNAGE	AGCE	RXSM1	RXSM0	AFCE	RXDI	DMG	ULS
1Ah RX Gain I	W	PRS	MIC	IGC1	IGC0	MGC1	MGC0	LGC1	LGC0
	R	--	MICR	IGCR1	IGCR0	MGCR1	MGCR0	LGCR1	LGCR0
1Bh RX Gain II	W	RSAGC1	RSAGC0	VTL2	VTL1	VTL0	VTH2	VTH1	VTH0
	R	RH7	RH6	RH5	RH4	RH3	RH2	RH1	RH0
1Ch RX Gain III	W	--	RDU	IFS1	IFS0	RSM1	RSM0	ERSSM	RSS
	R	RL7	RL6	RL5	RL4	RL3	RL2	RL1	RL0
1Dh RX Gain IV	W	LIMC	IFBC1	IFBC0	IFAS	MHC1	MHC0	LHC1	LHC0
1Eh RSSI Threshold	W	RTH7	RTH6	RTH5	RTH4	RTH3	RTH2	RTH1	RTH0
	R	ADC7	ADC6	ADC5	ADC4	ADC3	ADC2	ADC1	ADC0
1Fh ADC Control	W	AVSEL1	AVSEL0	MVSEL1	MVSEL0	RADC	FSARS	XADS	CDM
20h Code I	W	MCS	WHTS	FECS	CRCS	IDL1	IDL0	PML1	PML0
21h Code II	W	MSCRC	EDRL	HECS	ETH2	ETH1	ETH0	PMD1	PMD0
22h Code III	W	CRCINV	WS6	WS5	WS4	WS3	WS2	WS1	WS0
23h IF Calibration I	W	HFR	CKGS1	CKGS0	MFBS	MFB3	MFB2	MFB1	MFB0
	R	--	--	--	FBCF	FB3	FB2	FB1	FB0
24h IF Calibration II	W	PWORS	TRT2	TRT1	TRT0	ASMV2	ASMV1	ASMV0	AMVS
	R	--	--	--	FCD4	FCD3	FCD2	FCD1	FCD0
25h VCO current Calibration	W	ROSCS	RSIS	VCRLS	MVCS	VCOC3	VCOC2	VCOC1	VCOC0
	R	--	--	--	VCCF	VCB3	VCB2	VCB1	VCB0
26h VCO band Calibration I	W	DCD1	DCD0	DAGS	CWS	MVBS	MVB2	MVB1	MVB0
	R	-	-	-	-	VBCF	VB2	VB1	VB0
27h VCO band Calibration II	W	MDAG7	MDAG6	MDAG5	MDAG4	MDAG3	MDAG2	MDAG1	MDAG0
	R	ADAG7	ADAG6	ADAG5	ADAG4	ADAG3	ADAG2	ADAG1	ADAG0
28h VCO deviation Calibration I	W	DEVS3	DEVS2	DEVS1	DEVS0	DAMR_M	VMTE_M	VMS_M	MSEL
	R	DEVA7	DEVA6	DEVA5	DEVA4	DEVA3	DEVA2	DEVA1	DEVA0
29h VCO deviation Calibration II	W	MVDS	MDEV6	MDEV5	MDEV4	MDEV3	MDEV2	MDEV1	MDEV0
	R	ADEV7	ADEV6	ADEV5	ADEV4	ADEV3	ADEV2	ADEV1	ADEV0
2Ah DASP0	W	QLIM	RFSP	INTRC (CSXTL5)	CSXTL4	CSXTL3	CSXTL2	CSXTL1	CSXTL0
DASP1	W	STS	CELS	RGS	RGC1	RGC0	VRPL1	VRPL0	INTPRC
DASP2	W	VTRB3	VTRB2	VTRB1	VTRB0	VMRB3	VMRB2	VMRB1	VMRB0
DASP3	W	DCV7	DCV6	DCV5	DCV4	DCV3	DCV2	DCV1	DCV0
DASP4	W	VMG7	VMG6	VMG5	VMG4	VMG3	VMG2	VMG1	VMG0
	R	VMG7	VMG6	VMG5	VMG4	VMG3	VMG2	VMG1	VMG0
DASP5	W	--	--	PKT1	PKT0	PKS	PKIS1	PKIS0	IFPK
DASP6	W	--	HPLS	HRS	PACTL	IWS	CNT	MXD	LXD

2Bh VCO modulation Delay	W	DMV1	DMV0	DEVFD2	DEVFD1	DEVFD0	DEVD2	DEVD1	DEVD0
2Ch Battery detect	W	LVR	RGV1	RGV0	QDS	BVT2	BVT1	BVT0	BD_E
	R	--	RGV1	RGV0	BDF	BVT2	BVT1	BVT0	BD_E
2Dh TX test	W	RMP1	RMP0	TXCS	PAC1	PAC0	TBG2	TBG1	TBG0
2Eh Rx DEM test I	W	DMT	DCM1	DCM0	MLP1	MLP0	SLF2	SLF1	SLF0
2Fh Rx DEM test II	W	DCH1	DCH0	DCL2	DCL1	DCL0	RAW	CDTM1	CDTM0
30h Charge Pump Current I	W	CPM3	CPM2	CPM1	CPM0	CPT3	CPT2	CPT1	CPT0
31h Charge Pump Current II	W	CPTX3	CPTX2	CPTX1	CPTX0	CPRX3	CPRX2	CPRX1	CPRX0
32h Crystal test	W	CDPM	CPS	CPH	CPCS	DBD	XCC	XCP1	XCP0
33h PLL test	W	MDEN	OLM	PRIC1	PRIC0	PRRC1	PRRC0	SDPW	NSDO
34h VCO test	W	DEVGD2	DEVGD1	DEVGD0	TLB1	TLB0	RLB1	RLB0	VBS
35h RF Analog test	W	AGT3	AGT2	AGT1	AGT0	RFT3	RFT2	RFT1	RFT0
36h Key Data	W/R	KEY7	KEY6	KEY5	KEY4	KEY3	KEY2	KEY1	KEY0
37h Channel Select	W	CHI3	CHI2	CHI1	CHI0	CHD3	CHD2	CHD1	CHD0
38h ROM_P0	W	MPOR	EPRG	MIGS	MRGS	MRSS	MTMS	MADS	MBGS
ROMP1	W	APG	MPA1	MPA0	FBG4	FBG3	FBG2	FBG1	FBG0
ROMP2	W	PTM1	PTM0	CTR5	CTR4	CTR3	CTR2	CTR1	CTR0
ROMP3	W	--	--	CRS2	CRS1	CRS0	CTS2	CTS1	CTS0
ROMP4	W	--	STMP	STM5	STM4	STM3	STM2	STM1	STM0
39h Data Rate CLK	W	SDR7	SDR6	SDR5	SDR4	SDR3	SDR2	SDR1	SDR0
3Ah FCR	W	FCL1	FCL0	ARC3	ARC2	ARC1	ARC0	EACKS	EARTS
	R	ARTEF	VPOAK	RCR3	RCR2	RCR1	RCR0	EACKS	EARTS
3Bh ARD	W	ARD7	ARD6	ARD5	ARD4	ARD3	ARD2	ARD1	ARD0
3Ch AFEP	W	EACKF	SPSS	ACKFEP5	ACKFEP4	ACKFEP3	ACKFEP2	ACKFEP1	ACKFEP0
	R	--	--	EARTS	EARTS	EARTS	TXSID2	TXSID1	TXSID0
3Dh FCB	W/R	F7	F6	F5	F4	F3	F2	F1	F0
3Eh KEYC	W	MEDCS	AFIDS	ARTMS	MIDS	AESS	--	AKFS	EDCRS
3Fh USID	W	RND7	RND6	RND5	RND4	RND3	RND2	RND1	RND0

Legend: -- = unimplemented

## 9.2 Control register description

### 9.2.1 Mode Register (Address: 00h)

Name	R/W	Bit 7	Bit 6	Bit 5	Bit 4	Bit 3	Bit 2	Bit 1	Bit 0
Mode	R	HECF	FECF	CRCF	CER	XER	PLLER	TRSR	TRER
	W	RESETN	RESETN	RESETN	RESETN	RESETN	RESETN	RESETN	RESETN

**RESETN:** Write to this register by 0x00 to issue reset command, then it is auto clear

**HECF:** Head Control Flag. (HECF will be clear after issue a strobe command.)

HEC is CRC-8 result for the optional Packet Header (Please refer to chapter 16 for details)

[0]: HEC pass. [1]: HEC error.

**FECF:** FEC flag. (FECF will be clear after issue any strobe command.)

[0]: FEC pass. [1]: FEC error.

**CRCF:** CRC flag. (CRCF will be clear after issue any strobe command.)

[0]: CRC pass. [1]: CRC error.

**CER:** RF chip enable status.

[0]: RF chip is disabled. [1]: RF chip is enabled.

**XER:** Internal crystal oscillator enabled status.

[0]: Crystal oscillator is disabled. [1]: Crystal oscillator is enabled.

**PLLE:** PLL enabled status.

[0]: PLL is disabled. [1]: PLL is enabled.

**TRER:** TRX state enabled status.

[0]: TRX is disabled. [1]: TRX is enabled.

**TRSR:** TRX Status Register.

[0]: RX state. [1]: TX state.

Serviceable if TRER=1 (TRX is enable).

### 9.2.2 Mode Control Register (Address: 01h)

Name	R/W	Bit 7	Bit 6	Bit 5	Bit 4	Bit 3	Bit 2	Bit 1	Bit 0
Mode Control I	R	DDPC	ARSSI	AIF	DFCD	WORE	FMT	FMS	ADCM
	W	DDPC	ARSSI	AIF	CD	WORE	FMT	FMS	ADCM

**DDPC (Direct mode data pin control):** Direct mode modem data can be accessed via SDIO pin.

[0]: Disable. [1]: Enable.

**ARSSI:** Auto RSSI measurement while entering RX mode.

[0]: Disable. [1]: Enable.

**AIF (Auto IF Offset):** RF LO frequency will auto offset one IF frequency while entering RX mode.

[0]: Disable. [1]: Enable.

**CD:** Carrier detector (Read only).

[0]: Input power below threshold. [1]: Input power above threshold.

**DFCD:** Data Filter by CD : The received packet would be filtered if the input power level is below RTH (1Eh).

[0]: Disable. [1]: Enable.

**WORE:** WOR (Wake On RX) Function Enable.

[0]: Disable. [1]: Enable.

**FMT:** Reserved for internal usage only. Shall be set to [0].

**FMS:** Direct/FIFO mode select.

[0]: Direct mode. [1]: FIFO mode.

**ADCM:** ADC measurement enable (Auto clear when done).

[0]: Disable measurement or measurement finished. [1]: Enable measurement.

Refer to chapter 17 for details.

**9.2.3 Calibration Control Register (Address: 02h)**

Name	R/W	Bit 7	Bit 6	Bit 5	Bit 4	Bit 3	Bit 2	Bit 1	Bit 0
Mode Control II	R/W	--	--	--	VCC	VBC	VDC	FBC	RSSC

**VCC: VCO Current calibration enable (Auto clear when done).**

[0]: Disable. [1]: Enable.

**VBC: VCO Bank calibration enable (Auto clear when done).**

[0]: Disable. [1]: Enable.

**VDC: VCO Deviation calibration enable (Auto clear when done).**

[0]: Disable. [1]: Enable.

**FBC: IF Filter Bank calibration enable (Auto clear when done).**

[0]: Disable. [1]: Enable.

**RSSC: RSSI calibration enable (Auto clear when done).**

[0]: Disable. [1]: Enable.

**9.2.4 FIFO Register I (Address: 03h)**

Name	R/W	Bit 15	Bit 14	Bit 13	Bit 12	Bit 11	Bit 10	Bit 9	Bit 8
FIFO I	W	--	--	--	--	FEP11	FEP10	FEP9	FEP8
	R	--	--	--	--	LENF11	LENF10	LENF9	LENF8
	W	FEP7	FEP6	FEP5	FEP4	FEP3	FEP2	FEP1	FEP0
	R	LENF7	LENF6	LENF5	LENF4	LENF3	LENF2	LENF1	LENF0

**FEP [11:0]: FIFO End Pointer for TX FIFO and Rx FIFO.**

Data Sequence is FEP[7:0] and FEP[15:8].

Please refer to chapter 16 for details.

**LENF [11:0]: Received FIFO Length for dynamic FIFO function. (Ready Only)**

When EDRL =1, that means dynamic FIFO is enabled, MCU can read LENF [11:0] to know the RX FIFO length of the coming packet. Please refer to chapter 16 for details.

**9.2.5 FIFO Register II (Address: 04h)**

Name	R/W	Bit 7	Bit 6	Bit 5	Bit 4	Bit 3	Bit 2	Bit 1	Bit 0
FIFO II	W	FPM1	FPM0	PSA5	PSA4	PSA3	PSA2	PSA1	PSA0

**FPM [1:0]: FIFO Pointer Margin**

**PSA [5:0]: Used for Segment FIFO.**

Refer to chapter 16 for details.

**9.2.6 FIFO DATA Register (Address: 05h)**

Bit	R/W	Bit 7	Bit 6	Bit 5	Bit 4	Bit 3	Bit 2	Bit 1	Bit 0
Name	W	TX-FIFO[7:0]							
	R/W	RX-FIFO[7:0]							

**FIFO [7:0]: TX FIFO / RX FIFO**

TX FIFO and RX FIFO share the same address (05h).

TX FIFO and RX FIFO are separated physical **64 Bytes**.

Refer to chapter 16 for details.

**9.2.7 ID DATA Register (Address: 06h)**

Name	R/W	Bit 7	Bit 6	Bit 5	Bit 4	Bit 3	Bit 2	Bit 1	Bit 0
ID DATA	R/W	ID7	ID6	ID5	ID4	ID3	ID2	ID1	ID0

**ID [7:0]: ID data.**

When this address is accessed, ID Data is input or output sequential (ID Byte 0,1, 2 and 3) corresponding to Write or Read.



Recommend to set ID Byte 0 = 5xh or Axx.  
Refer to section 10.6 for details.

### 9.2.8 RC OSC Register I (Address: 07h)

Name	R/W	Bit 7	Bit 6	Bit 5	Bit 4	Bit 3	Bit 2	Bit 1	Bit 0
RC OSC I	R	RCOC7	RCOC6	RCOC5	RCOC4	RCOC3	RCOC2	RCOC1	RCOC0
	W	WOR_SL7	WOR_SL6	WOR_SL5	WOR_SL4	WOR_SL3	WOR_SL2	WOR_SL1	WOR_SL0

**RCOC [7:0]: Reserved for internal usage (read only).**

### 9.2.9 RC OSC Register II (Address: 08h)

Name	R/W	Bit 7	Bit 6	Bit 5	Bit 4	Bit 3	Bit 2	Bit 1	Bit 0
RC OSC II	W	WOR_SL9	WOR_SL8	WOR_AC5	WOR_AC4	WOR_AC3	WOR_AC2	WOR_AC1	WOR_AC0

**WOR\_AC [5:0]: 6-bits WOR Active Timer for WOR and TWOR Function**

**WOR\_SL [9:0]: 10-bits WOR Sleep Timer for WOR and TWOR Function.**  
WOR\_SL [9:0] are from address (07h) and (08h),

Active period = (WOR\_AC+1) x (1/4092).  
Sleep period = (WOR\_SL+1) x (1/32) x (1/4092).

### 9.2.10 RC OSC Register III (Address: 09h)

Name	R/W	Bit 7	Bit 6	Bit 5	Bit 4	Bit 3	Bit 2	Bit 1	Bit 0
RC OSC III	W	RTCS	RCO T2	RCOT1/ RTCC1	RCOT0/ RTCC0	CALWC	RCOSC_E	TSEL	TWORE
	R	--	--	--	--	CALWR	--	--	--

**RTCS: internal Oscillator selection in sleep mode. Recommend RTCS= [0].**  
[0]: RC oscillator. [1]: RTC oscillator.

**RCOT[2:0]: Reserved for internal used. Recommend RCOT= [000].**

**RCOT[1:0]: RCOSC current select for RC oscillator calibration.**  
[00]: 240nA [01]: 280nA [10]: 320nA [11]: 360nA

**TSEL: Timer select for TWOR function.**  
[0]: Use WOR\_AC. [1]: Use WOR\_SL.

**CALWC: RC Oscillator Calibration Enable.**  
[0]: Disable. [1]: Enable.

**CALWR: RC Oscillator Calibration ending indication.**  
[0]: ending. [1]: Not ending.

**RCOSC\_E: RC-oscillator enable.**  
[0]: Disable. [1]: Enable.

**TSEL: Timer Duty select for TWOR function.**  
[0]: Use WOR\_AC. [1]: Use WOR\_SL.

**TWORE: Enable TWOR function.**  
[0]: WOR mode. [1]: TWOR mode.

### 9.2.11 CKO Pin Control Register (Address: 0Ah)

Name	R/W	Bit 7	Bit 6	Bit 5	Bit 4	Bit 3	Bit 2	Bit 1	Bit 0
CKO Pin Control	W	ECKOE	CKOS3	CKOS2	CKOS1	CKOS0	CKOI	CKOE	SCKI

**ECKOE: CKO pin Output Enable.**  
[0]: Disable. [1]: Enable.

**CKOS [3:0]: CKO pin output select.**

- [0000]: DCK (TX data clock) in TX mode, RCK (RX recovery clock) in RX mode.
- [0001]: DCK (TX data clock) in TX mode, RCK (RX recovery clock) in RX mode.
- [0010]: FPF (FIFO pointer flag).
- [0011]: EOP, EOVCB, EOFBC, EOVCB, EOVCB, RSSC\_OK. (Internal usage only).
- [0100]: External clock output=  $F_{SYCK} / 2$ .
- [0101]: External clock output / 2=  $F_{SYCK} / 4$ .
- [0110]: RXD
- [0111]: FSYNC.
- [1000]: WCK.
- [1001]: PF8M.(8Mhz, internal usage)
- [1010]: ROSC.
- [1011]: MXDEC(SLF[0]=1:~OKADCN, SLF[1]=0: DEC , internal usage)
- [1100]: BDF (Battery Detect flag).
- [1101]:  $F_{SYCK} ..$
- [1110]: VPOAK.
- [1111]: WRTC (internal usage)

**CKOI: CKO pin output signal invert.**

[0]: Non-inverted output. [1]: Inverted output.

**CKOE: CKO pin Output Enable.**

[0]: High Z. [1]: Enable.

**SCKI: SPI clock input invert.**

[0]: Non-inverted input. [1]: Inverted input.

**9.2.12 GIO1 Pin Control Register I (Address: 0Bh)**

Name	R/W	Bit 7	Bit 6	Bit 5	Bit 4	Bit 3	Bit 2	Bit 1	Bit 0
GIO1 Pin Control I	W	VKM	VPM	GIO1S3	GIO1S2	GIO1S1	GIO1S0	GIO1I G	O1OE

**VKM: Valid packet mode select.**

[0]: by event. [1]: by pulse.

**VPM: Valid Pulse width select.**

[0]: 20u. [1]: 40u.

**TX Mode (disable auto-resend, EAR=0).**

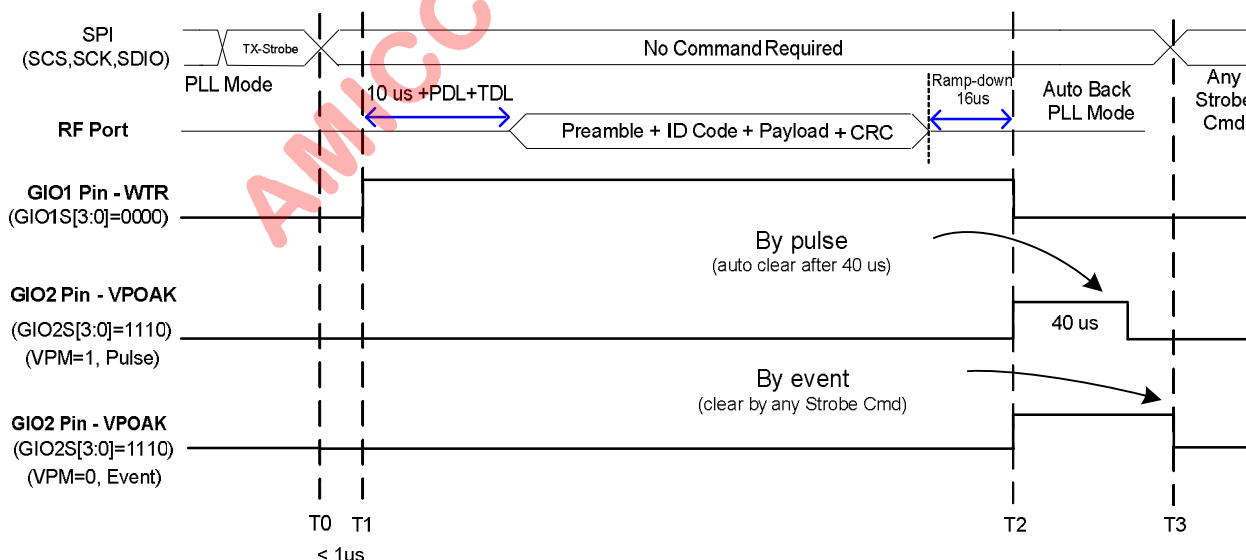

## RX Mode (disable Auto-ack, EAK =0).

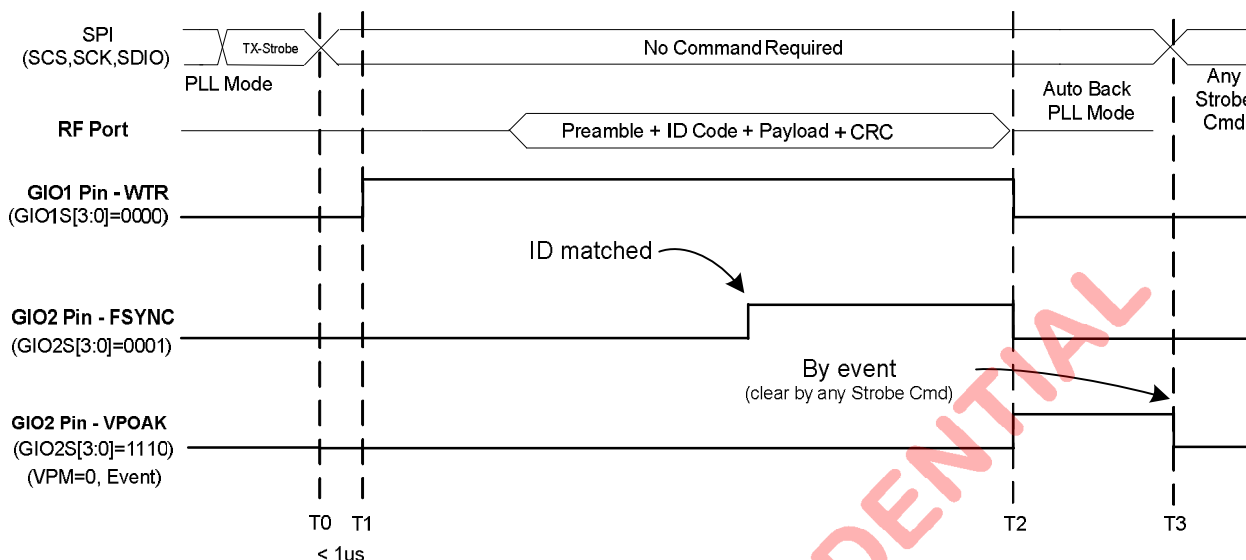

Note1, If auto-resend is enabled (EAR = 1), WTR behavior is different while it is output to GIO1 and GIO2.

Note2, If auto-ack is enabled (EAK = 1), WTR behavior is different while it is output to GIO1 and GIO2.

Note3, VPOAK's behavior is controlled by VPM (0Bh) and VPW (0Bh).

Refer to chapter 19 for details

## GIO1S [3:0]: GIO1 pin function select.

GIO1S [3:0]	TX state	RX state
[0000]	WTR (Wait until TX or RX finished)	
[0001]	EOAC (end of access code)	FSYNC (frame sync)
[0010]	TME0 (TX modulation enable)	CD (carrier detect)
[0011]	Preamble Detect Output (PMD0)	
[0100]	If RCOSC_E = 1, output TWOR. If RCOSC_E = 0, output CWTR signal. (internal usage)	
[0101]	In phase demodulator input (DMII) or VT[0] (internal usage)	
[0110]	SDO ( 4 wires SPI data out)	
[0111]	TRXD In/Out (Direct mode)	
[1000]	RXD (Direct mode)	
[1001]	TXD (Direct mode)	
[1010]	PDN_RX	
[1011]	External FSYNC input in RX direct mode (internal usage)	
[1100]	MXINC (SLF[0]=1:EOADC.SLF[1]=0:INC.) (internal usage)	
[1101]	FPF	
[1110]	VPOAK (Valid Packet or Auto ACK OK Output)	
[1111]	FMTDO (internal usage)	

If GIO1S = [0100] and RCOSC\_E = 0, CWTR is an internal signal to monitor TX/RX cycles of auto-ack and auto-resend. If GIO1S = [1011] and direct mode is selected, the internal frame sync function will be disabled. In such case, A7130 supports to accept an external frame sync signal from MCU to feed to GIO1 pin to determine the timing of fixing DC estimation voltage of demodulator.

## GIO1I: GIO1 pin output signal invert.

[0]: Non-inverted output. [1]: Inverted output.

## GIO1OE: GIO1 pin output enable.

[0]: High Z. [1]: Enable.

9.2.13 GIO2 Pin Control Register II (Address: 0Ch)

Name	R/W	Bit 7	Bit 6	Bit 5	Bit 4	Bit 3	Bit 2	Bit 1	Bit 0
GIO2 Pin Control II	W	BBCKS1	BBCKS0	GIO2S3	GIO2S2	GIO2S1	GIO2S0	GIO2I G	O2OE

**BBCKS [1:0]:** Clock select for digital block. Recommend BBCKS = [00].  
**[00]:** F<sub>SYCK</sub>. **[01]:** F<sub>SYCK</sub> / 2. **[10]:** F<sub>SYCK</sub> / 4. **[11]:** F<sub>SYCK</sub> / 8.

**GIO2S [3:0]:** GIO2 pin function select.

GIO2S	TX state	RX state
[0000]	WTR (Wait until TX or RX finished)	
[0001]	EOAC (end of access code)	FSYNC (frame sync)
[0010]	TME0 (TX modulation enable)	CD (carrier detect)
[0011]	Preamble Detect Output (PMDO)	
[0100]	If RCOSC_E =1, output TWOR. If RCOSC_E =0, output CWTR signal. (internal usage)	
[0101]	Quadrature phase demodulator input (DMIQ) (internal usage)	
[0110]	SDO (4 wires SPI data out)	
[0111]	TRXD In/Out (Direct mode)	
[1000]	RXD (Direct mode)	
[1001]	TXD (Direct mode)	
[1010]	PDN_TX	
[1011]	ROMOK(ROM Program OK) (internal usage)	
[1100]	BDF (Battery Detect Flag)	
[1101]	FPF	
[1110]	VPOAK (Valid Packet or Auto ACK OK Output)	
[1111]	DCK (internal usage)	

If GIO2S = [0100] and RCOSC\_E = 0, CWTR is an internal signal to monitor TX/RX cycles of auto-ack and auto-resend.

**GIO2I:** GIO2 pin output signal invert.

**[0]:** Non-inverted output. **[1]:** Inverted output.

**GIO2OE:** GIO2 pin Output Enable.

**[0]:** High Z. **[1]:** Enable.

In TX mode

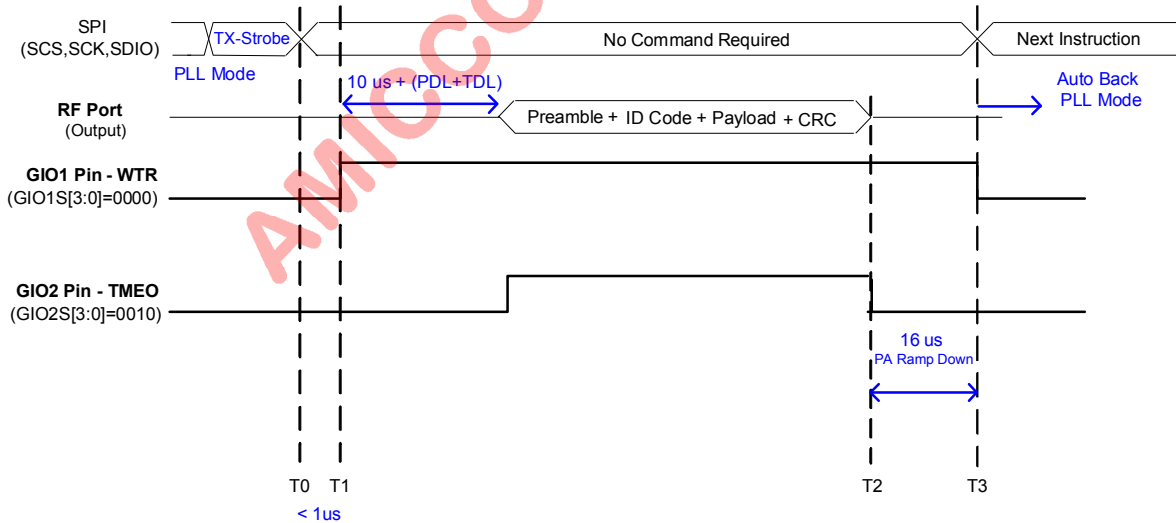

In RX mode

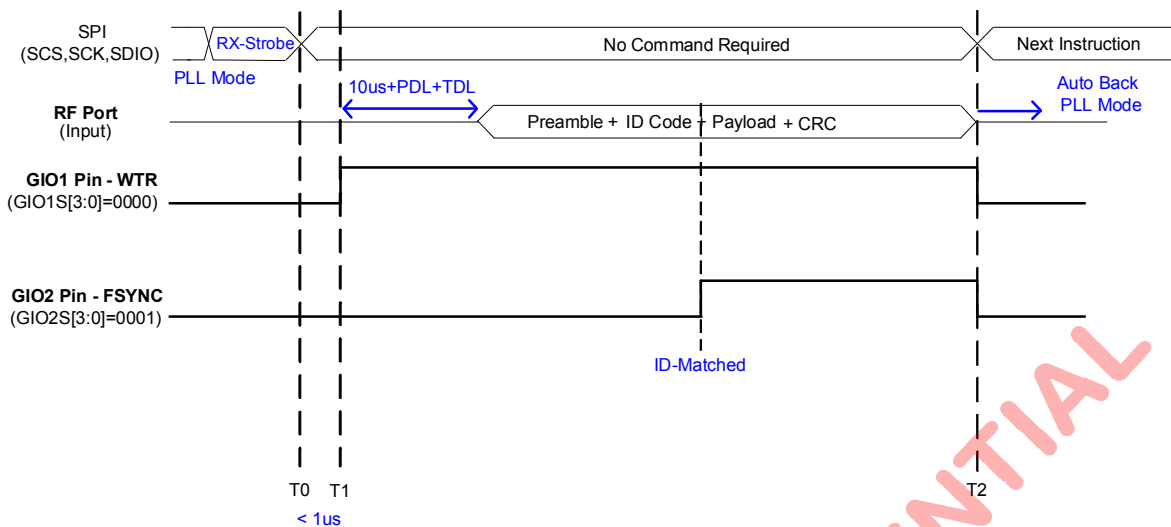

### 9.2.14 Clock Register (Address: 0Dh)

Name	R/W	Bit 7	Bit 6	Bit 5	Bit 4	Bit 3	Bit 2	Bit 1	Bit 0
Clock	W	CGC1	CGC0	GRC3	GRC2	GRC1	GRC0	CGS	XS
	R	IFS1	IFS0	GRC3	GRC2	GRC1	GRC0	--	--

**CGC [1:0]:** Clock Gen. Current select. Shall be set to [10].

**GRC [3:0]:** Clock generation reference counter. Recommend GRC = [0111] for 16MHz Xtal.

GRC [3:0] is used to let below formula be true when CGS = 1.

$$F_{XTAL} \times (DBL+1) / (GRC+1) = 2MHz.$$

**CGS:** Clock generator enable. Recommend CGS = [1]

[0]: Disable. [1]: Enable.

**XS:** Crystal oscillator select. Recommend XS = [1]

[0]: External clock. [1]: Crystal.

**IFS [1:0]:** IF band selection. (Ready only)

### 9.2.15 PLL Register I (Address: 0Eh)

Name	R/W	Bit 7	Bit 6	Bit 5	Bit 4	Bit 3	Bit 2	Bit 1	Bit 0
PLL I	R/W	CHN7	CHN6	CHN5	CHN4	CHN3	CHN2	CHN1	CHN0

**CHN [7:0]:** LO channel number select.

Refer to chapter 14 for details.

### 9.2.16 PLL Register II (Address: 0Fh)

Name	R/W	Bit 7	Bit 6	Bit 5	Bit 4	Bit 3	Bit 2	Bit 1	Bit 0
PLL II	R	DBL	RRC1	RRC0	CHR3	CHR2	CHR1	CHR0	IP8
	W	DBL	RRC1	RRC0	CHR3	CHR2	CHR1	CHR0	BIP8

**DBL:** Crystal frequency doublers selection.

[0]: Disable.  $F_{XREF} = F_{XTAL}$ .

[1]: Enable.  $F_{XREF} = 2 * F_{XTAL}$ .

In FIFO mode, recommend to set DBL = 0.

In Direct mode, recommend to set DBL = 1.

Please refer to A7130 reference code for details.

**RRC [1:0]:** RF PLL reference counter setting. Recommend RRC = [00].

The PLL comparison frequency,  $F_{PPD} = F_{CRYSTAL} * (DBL+1) / (RRC+1)$ .

**CHR [3:0]: PLL channel step setting.**

In FIFO mode, recommend to set CHR [3:0] = [0111].

In Direct mode, recommend to set CHR [3:0] = [1111].

Please refer to chapter 14 and A7130 reference code for details.

**9.2.17 PLL Register III (Address: 10h)**

Name	R/W	Bit 7	Bit 6	Bit 5	Bit 4	Bit 3	Bit 2	Bit 1	Bit 0
PLL III	R	IP7	IP6	IP5	IP4	IP3	IP2	IP1	IP0
	W	BIP7	BIP6	BIP5	BIP4	BIP3	BIP2	BIP1	BIP0

**BIP [8:0]: LO base frequency integer part setting. (0Fh and 10h)**

In FIFO mode, recommend to set BIP [8:0] = [0x096].

In Direct mode, recommend to set BIP [8:0] = [0x04B].

Please refer to chapter 14 and A7130 reference code for details.

**IP [8:0]: LO frequency integer part value.**

IP [8:0] are from address (0Fh) and (10h),

Refer to chapter 14 for details.

**9.2.18 PLL Register IV (Address: 11h)**

Name	R/W	Bit 7	Bit 6	Bit 5	Bit 4	Bit 3	Bit 2	Bit 1	Bit 0
PLL IV	R	RAC15	RAC14	RAC13	RAC12	RAC11	RAC10	RAC9	RAC8
	W	BFP15	BFP14	BFP13	BFP12	BFP11	BFP10	BFP9	BFP8

**9.2.19 PLL Register V (Address: 12h)**

Name	R/W	Bit 7	Bit 6	Bit 5	Bit 4	Bit 3	Bit 2	Bit 1	Bit 0
PLL V	R	RAC7	RAC6	RAC5	RAC4	RAC3	RAC2	RAC1	RAC0
	W	BFP7	BFP6	BFP5	BFP4	BFP3	BFP2	BFP1	BFP0

**BFP [15:0]: LO base frequency fractional part setting. (11h and 12h)**

In FIFO mode, recommend to set BFP [15:0] = [0x0004].

In Direct mode, recommend to set BFP [15:0] = [0x0002].

Please refer to chapter 14 and A7130 reference code for details.

**RAC [15:0]: Auto Frequency compensation value if AFC (19h) =1.**

	RAC [15:0]	Note
AFC = 1	PLLFF [15:0]	LO Freq. compensation value
AFC = 0	{SYNCF, AC [14:0]}	

**9.2.20 Channel Group Register I (Address: 13h)**

Name	R/W	Bit 7	Bit 6	Bit 5	Bit 4	Bit 3	Bit 2	Bit 1	Bit 0
CHGI	R/W	CHGL7	CHGL6	CHGL5	CHGL4	CHGL3	CHGL2	CHGL1	CHGL0

**CHGL [7:0]: PLL channel group low boundary setting for auto-calibration. Recommended CHGL[7:0] = 0x3C.**

Refer to A7130 reference code for details.

**9.2.21 Channel Group Register II (Address: 14h)**

Name	R/W	Bit 7	Bit 6	Bit 5	Bit 4	Bit 3	Bit 2	Bit 1	Bit 0
CHGII	R/W	CHGH7	CHGH6	CHGH5	CHGH4	CHGH3	CHGH2	CHGH1	CHGH0

**CHGH [7:0]: PLL channel group high boundary setting for auto-calibration. Recommended CHGH[7:0] = 0x78.**

Refer to A7130 reference code for details.

**PLL calibration frequency is divided into 3 groups by CHGL and CHGH:**

	Channel
Group1	0 ~ CHGL-1
Group2	CHGL ~ CHGH-1

Group3	CHGH ~ 255
--------	------------

### 9.2.22 TX Register I (Address: 15h)

Name	R/W	Bit 7	Bit 6	Bit 5	Bit 4	Bit 3	Bit 2	Bit 1	Bit 0
TX I	W	GDR	GF	TMDE	TXDI	TME	FDP2	FDP1	FDP0

**GDR: Gaussian Filter Over Sampling Rate Select. Recommend GDR = [1].**

[0]: BT= 0.7 [1]: BT= 0.5

**GF: Gaussian Filter Select.**

[0]: Disable. [1]: Enable.

**TMDE: TX modulation enable for VCO modulation. Recommend TMDE = [1].**

[0]: Disable. [1]: Enable.

**TXDI: TX data invert. Recommend TXDI = [0].**

[0]: Non-invert. [1]: Invert.

**TME: TX modulation enable. Recommend TME = [1].**

[0]: Disable. [1]: Enable.

**FDP [2:0]: Frequency deviation power setting. Recommend FDP = [110].**

In FIFO mode, recommend to set FDP [2:0] = [111].

In Direct mode, recommend to set FDP [2:0] = [110].

Please refer to chapter 14 and A7130 reference code for details.

### 9.2.23 TX Register II (Address: 16h)

Name	R/W	Bit 7	Bit 6	Bit 5	Bit 4	Bit 3	Bit 2	Bit 1	Bit 0
TXI	W	FD7	FD6	FD5	FD4	FD3	FD2	FD1	FD0

**FD [7:0]: Frequency deviation setting.**

$$F_{DEV} = (F_{PFD} / 2^{16}) \times FD[7:0] \times 2^{(FDP-1)}$$

Where  $F_{PFD} = F_{XTAL} * (DBL+1) / (RRC [1:0]+1)$ , PLL comparison frequency.

Data Rate	FDP[2:0]	FD[7:0]	Fdev
4Mbps FIFO mode	111	0x40	1MHz
4Mbps Direct mode	110	0x40	1MHz

### 9.2.24 Delay Register I (Address: 17h)

Name	R/W	Bit 7	Bit 6	Bit 5	Bit 4	Bit 3	Bit 2	Bit 1	Bit 0
Delay	W	DPR2	DPR1	DPR0	TDL1	TDL0	PDL2	PDL1	PDL0

**DPR [2:0]: Delay scale. Recommend DPR = [000].**

**TDL [1:0]: Delay for TX settling from WPLL to TX.**

TDL Delay= 20 \* (TDL [1:0]+1)\*(DPR [2:0]+1) us.

DPR [2:0]	TDL [1:0]	WPLL to TX	Note
000	00	20 us	
000	01	40 us	
000	10	60 us	Recommend
000	11	80 us	

**PDL [2:0]: Delay for TX settling from PLL to WPLL.**

PDL Delay= 10 + {20 \* (PDL [2:0]+1)\*(DPR [2:0]+1)} us.

DPR [2:0]	PDL [2:0]	PLL to WPLL (LO freq changed)	Note
000	000	30 us	Recommend
000	001	50 us	

000	010	70 us	
000	011	90 us	
000	100	110 us	

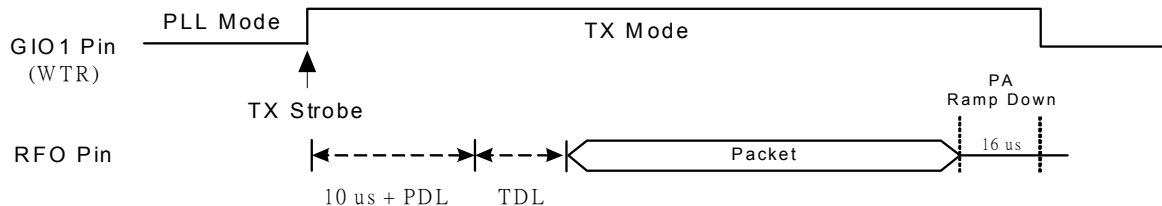

### 9.2.25 Delay Register II (Address: 18h)

Name	R/W	Bit 7	Bit 6	Bit 5	Bit 4	Bit 3	Bit 2	Bit 1	Bit 0
Delay	W	WSEL2	WSEL1	WSEL0	RSSC_D1	RSSC_D0	RS_DLY2	RS_DLY1	RS_DLY0

**WSEL [2:0]: XTAL settling delay setting (200us ~ 2.5ms). Recommend WSEL = [011].**

[000]: 200us. [001]: 400us. [010]: 600us. [011]: 800us.  
 [100]: 1ms. [101]: 1.5ms. [110]: 2ms. [111]: 2.5ms.

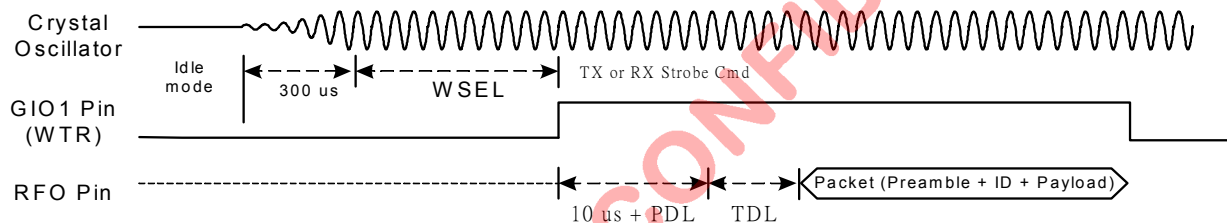

**RSSC\_D [1:0]: RSSI calibration switching time (10us ~ 40us). Recommend RSSC\_D = [00].**

[00]: 10us. [01]: 20us. [10]: 30us. [11]: 40us.

**RS\_DLY [2:0]: RSSI measurement delay (10us ~ 80us). Recommend RS\_DLY = [000].**

[000]: 10us. [001]: 20us. [010]: 30us. [011]: 40us.  
 [100]: 50us. [101]: 60us. [110]: 70us. [111]: 80us.

### 9.2.26 RX Register (Address: 19h)

Name	R/W	Bit 7	Bit 6	Bit 5	Bit 4	Bit 3	Bit 2	Bit 1	Bit 0
RX	W	LNAGE	AGCE	RXSM1	RXSM0	AFCE	RXDI	DMG	ULS

**LNAGE: Auto LNA Gain Control Select.**

[0]: Disable. [1]: Enable.

**AGCE: Auto Front end Gain Control Select.**

[0]: Disable. [1]: Enable.

**RXSM1: RX clock recovery circuit moving average filter length. Recommend RXSM1 = [1].**

[0]: 4 bits. [1]: 8 bits.

**RXSM0: Demodulator LPF Bandwidth Select. Recommend RXSM0 = [1].**

[0]: 2\*IF. [1]: 1\*IF.

**AFCE: Frequency compensation select.**

[0]: Disable. [1]: Enable.

**RXDI: RX data output invert. Recommend RXDI = [0].**

[0]: Non-inverted output. [1]: Inverted output.

**DMG: Demodulator Gain Select. Recommend DMG = [1].**

[0]: x 1. [1]: x 3.



**ULS: RX Up/Low side band select. Recommend ULS = [0].**

[0]: Up side band, [1]: Low side band.

Refer to section 14.2 for details.

### 9.2.27 RX Gain Register I (Address: 1Ah)

Name	R/W	Bit 7	Bit 6	Bit 5	Bit 4	Bit 3	Bit 2	Bit 1	Bit 0
RX Gain I	W	PRS	MIC	IGC1	IGC0	MGC1	MGC0	LGC1	LGC0
	R	--	MICR	IGCR1	IGCR0	MGCR1	MGCR0	LGCR1	LGCR0

**PRS: Limiter amplifier discharge manual select. Recommend PRS = [0].**

**MIC: Mixer buffer gain setting. Recommend MIC = [1].**

[0]: 0dB. [1]: 6dB.

**IGC [1:0]: IFA Attenuation Select. Recommend IGC = [10].**

[00]: 0dB. [01]: 6dB. [10]: 12dB. [11]: 18dB.

**MGC [1:0]: Mixer Gain Attenuation select. Recommend MGC = [11].**

[00]: 0dB. [01]: 6dB. [10]: 12dB. [11]: 18dB.

**LGC [1:0]: LNA Gain Attenuation select. Recommend LGC = [11].**

[00]: 0dB. [01]: 6dB. [10]: 12dB. [11]: 18dB.

### 9.2.28 RX Gain Register II (Address: 1Bh)

Name	R/W	Bit 7	Bit 6	Bit 5	Bit 4	Bit 3	Bit 2	Bit 1	Bit 0
RX Gain II	R	RH7	RH6	RH5	RH4	RH3	RH2	RH1	RH0
	W	RSAGC1	RSAGC0	VTL2	VTL1	VTL0	VTH2	VTH1	VTH0

**RSAGC [1:0]: AGC clock select. Recommend RSAGC = [11].**

[00]: IF / 8. [01]: IF / 4. [10]: IF / 2. [11]: IF.

**VTL [2:0]: VCO tuning voltage lower threshold level setting. Recommend VTL = [000].**

[000]: 0.1V. [001]: 0.2V. [010]: 0.3V. [011]: 0.4V.

[100]: 0.5V. [101]: 0.6V. [110]: 0.7V. [111]: 0.8V.

**VTH [2:0]: VCO tuning voltage upper threshold level setting. Recommend VTH = [010].**

[000]: VDD\_A – 0.6V. [001]: VDD\_A – 0.7V. [010]: VDD\_A – 0.8V. [011]: VDD\_A – 0.9V.

[100]: VDD\_A – 1.0V. [101]: VDD\_A – 1.1V. [110]: VDD\_A – 1.2V. [111]: VDD\_A – 1.3V.

Remark: VDD\_A is on chip analog regulator output voltage where is set to 1.8V.

**RH [7:0]: RSSI Calibration High Threshold. (Read only)**

### 9.2.29 RX Gain Register III (Address: 1Ch)

Name	R/W	Bit 7	Bit 6	Bit 5	Bit 4	Bit 3	Bit 2	Bit 1	Bit 0
RX Gain III	R	RL7	RL6	RL5	RL4	RL3	RL2	RL1	RL0
	W	--	RDU	IFS1	IFS0	RSM1	RSM0	ERSSM	RSS

**RDU: Clock Generator Select. Recommend RDU = [0].**

[0]: 128MHZ [1]: 96MHZ.

**IFS [1:0]: IF Frequency Select.**

[00]: reserved. [01]: reserved. [10]: reserved [11]: 4MHZ.

**RSM [1:0]: RSSI Margin = RTH – RTL. Recommend RSM = [11].**

[00]: 5. [01]: 10. [10]: 15. [11]: 20.

Refer to chapter 17 for details.

**ERSSM: Ending Mode Select in RSSI Measurement. Recommend ERSSM = [0].**

[0]: RSSI ending by RX. [1]: RSSI ending by SYNC\_Ok.

**RSS: RSSI measurement select. (XADS=0, RSS=0, default mode is thermal sensor.)**

[0]: Disable. [1]: Enable (recommend).

RL [7:0]: RSSI Calibration Low Threshold. (Ready only)

### 9.2.30 RX Gain Register IV (Address: 1Dh)

Name	R/W	Bit 7	Bit 6	Bit 5	Bit 4	Bit 3	Bit 2	Bit 1	Bit 0
RX Gain III	W	LIMC	IFBC1	IFBC0	IFAS	MHC1	MHC0	LHC1	LHC0

**LIMC: IF limiter current select. Recommend LIMC = [1].**  
 [0]: 0.3mA. [1]: 0.6mA.

**IFBC [1:0]: IF BPF current Select. Recommend IFBC = [11].**  
 [00]: 0.75 mA.. [01]: 1.4mA. [10]: 2.1mA. [11]: 3.5mA.

**IFAS: IF Amp current select. Recommend IFAS = [0].**  
 [0]: 0.3mA. [1]: 0.6mA.

**MHC: Mixer Current Select. Recommend MHC = [01].**  
 [00]: 0.6mA. [01]: 1.2mA. [10]: reserved. [11]: reserved.

**LHC[1:0]: LNA Current Select. Recommend LHC = [11].**  
 [00]: 0.5mA. [01]: 1mA. [10]: 1.5mA. [11]: 2mA.

### 9.2.31 RSSI Threshold Register (Address: 1Eh)

Name	R/W	Bit 7	Bit 6	Bit 5	Bit 4	Bit 3	Bit 2	Bit 1	Bit 0
RSSI Threshold	R	ADC7	ADC6	ADC5	ADC4	ADC3	ADC2	ADC1	ADC0
	W	RTH7	RTH6	RTH5	RTH4	RTH3	RTH2	RTH1	RTH0

**RTH [7:0]: Carrier detect threshold.**

Refer to Chapter 17 for details.

CD (Carrier Detect)=1 when  $RSSI \geq RT H$ .

CD (Carrier Detect)=0 when  $RSSI < RTL$ .

**ADC [7:0]: ADC output value for RSSI measurement.**

ADC input voltage=  $1.2 * ADC [7:0] / 256 V$ .

### 9.2.32 ADC Control Register (Address: 1Fh)

Name	R/W	Bit 7	Bit 6	Bit 5	Bit 4	Bit 3	Bit 2	Bit 1	Bit 0
ADC Control	W	AVSEL1	AVSEL0	MVSEL1	MVSEL0	RADC	FSARS	XADS	CDM

**AVSEL [1:0]: ADC average times (for Carrier / temperature sensor / external ADC). Recommend AVSEL = [11].**  
 [00]: No average. [01]: Average 2 times. [10]: Average 4 times. [11]: Average 8 times.

**MVSEL [1:0]: ADC average times (for VCO calibration and RSSI). Recommend MVSEL = [11].**  
 [00]: Average 8 times. [01]: Average 16 times. [10]: Average 32 times. [11]: Average 64 times.

**RADC: ADC Read Out Average Mode. Recommend RADC = [0].**

[0]: by AVSEL.

[1]: by MVSEL.

**FSARS: ADC clock select. Recommend FSARS = [0].**

[0]: 4MHz. [1]: 8MHz.

**XADS: External ADC Input Signal Select.**

[0]: Disable. [1]: Enable.

**CDM: RSSI measurement mode. Recommend CDM = [1].**

[0]: Single mode. [1]: Continuous mode.

### 9.2.33 Code Register I (Address: 20h)

Name	R/W	Bit 7	Bit 6	Bit 5	Bit 4	Bit 3	Bit 2	Bit 1	Bit 0
Code I	W	MCS	WHTS	FECS	CRCS	IDL1	IDL0	PML1	PML0

**MSC: Manchester Enable.**

[0]: Disable. [1]: Enable.

**WHTS: Data Whitening (Data Encryption) Select.**

[0]: Disable. [1]: Enable (The data is whitening by multiplying PN7).

**FECS: FEC Select.**

[0]: Disable. [1]: Enable (The FEC is (7, 4) Hamming code).

**CRCS: CRC Select. Recommend CRCS = [1].**

[0]: Disable. [1]: Enable.

**IDL [1:0]: ID Code Length Select. Recommend IDL= [01].**

[00]: 2 bytes. [01]: 4 bytes. [10]: 6 bytes. [11]: 8 bytes.

**PML [1:0]: Preamble Length Select. Recommend PML= [11].**

[00]: 1 byte. [01]: 2 bytes. [10]: 3 bytes. [11]: 4 bytes.

**9.2.34 Code Register II (Address: 21h)**

Name	R/W	Bit 7	Bit 6	Bit 5	Bit 4	Bit 3	Bit 2	Bit 1	Bit 0
Code II	W	MSCRC	EDRL	HECS	ETH2	ETH1	ETH0	PMD1	PMD0

**MSCRC: Mask CRC (CRC Data Filtering Enable). Recommend MSCRC = [1].**

[0]: Disable. [1]: Enable.

**EDRL: Enable FIFO Dynamic Length**

[0]: Disable. [1]: Enable.

Please refer to chapter 16 for details.

**HECS: HEC Header CRC-8 select.**

[0]: Disable. [1]: Enable.

Please refer to chapter 16 for details.

**ETH [2:0]: Received ID Code Error Tolerance. Recommend ETH = [001].**

[000]: 0 bit, [001]: 1 bit. [010]: 2 bit. [011]: 3 bit. [100]: 4 bit, [101]: 5 bit. [110]: 6 bit. [111]: 7 bit.

**PMD [1:0]: Preamble pattern detection length. Recommend PMD = [10].**

[00]: 0bit. [01]: 4bits. [10]: 8bits. [11]: 16bits.

**9.2.35 Code Register III (Address: 22h)**

Name	R/W	Bit 7	Bit 6	Bit 5	Bit 4	Bit 3	Bit 2	Bit 1	Bit 0
Code III	W	CRCINV	WS6	WS5	WS4	WS3	WS2	WS1	WS0

**CRCINV: CRC Inverted Select.**

[0]: Non-inverted. [1]: inverted.

**WS [6:0]: Data Whitening seed setting (data encryption key).**

The data is whitened by multiplying with PN7.

Please refer to chapter 16 for details.

**9.2.36 IF Calibration Register I (Address: 23h)**

Name	R/W	Bit 7	Bit 6	Bit 5	Bit 4	Bit 3	Bit 2	Bit 1	Bit 0
IF Calibration I	R	--	--	--	FBCF	FB3	FB2	FB1	FB0
	W	HFR	CKGS1	CKGS0	MFBS	MFB3	MFB2	MFB1	MFB0

**HFR: Half Rate setting. Recommend HFR = [0].**

[0]: Clk gen. by 32 x Data Rate. [1]: Clk gen. by 16 x Data Rate.

**CKGS[1:0]: Clock gen. data rate manual setting. Recommend CKGS = [11].**

[00]: reserved. [01]: reserved. [10]: reserved. [11]: 4MHZ.

When RDU=0, CKGS[1:0] = IFS[1:0]

When RDU=1, CKGS[1:0] = Manual setting.

**MFBS: IF filter calibration value select. Recommend MFBS = [0].**

[0]: Auto calibration value. [1]: Manual calibration value.

**MFB [3:0]: IF filter manual calibration value.**

**FBCF: IF filter auto calibration flag (read only).**

[0]: Pass. [1]: Fail.

**FB [3:0]: IF filter calibration value (read only).**

MFBS= 0: Auto calibration value (AFB),

MFBS= 1: Manual calibration value (MFB).

### 9.2.37 IF Calibration Register II (Address: 24h)

Name	R/W	Bit 7	Bit 6	Bit 5	Bit 4	Bit 3	Bit 2	Bit 1	Bit 0
IF Calibration II	R	--	--		FCD4	FCD3	FCD2	FCD1	FCD0
	W	PWORS	TRT2	TRT1	TRT0	ASMV2	ASMV1	ASMV0	AMVS

**PWORS: TX high power setting. Recommend PWORS = [1].**

[0]: Disable. [1]: Enable.

**TRT [2:0]: TX Ramp down discharge current select. Recommend TRT = [111].**

**AMSV [2:0]: TX Ramp up Timing Select. Recommend AMSV = [111].**

[000]: 2us, [001]: 4us. [010]: 6us. [011]: 8us. [100]: 10us, [101]: 12us. [110]: 14us. [111]: 16us.

Real case of TX ramping up is AMSV [2:0] multiplied by 2<sup>(RMP[1:0])</sup>

**AMVS: TX Ramp Up Enable. Recommend AMVS = [1].**

[0]: Disable. [1]: Enable.

**FCD [4:0]: IF filter calibration deviation from goal (read only).**

### 9.2.38 VCO current Calibration Register (Address: 25h)

Name	R/W	Bit 7	Bit 6	Bit 5	Bit 4	Bit 3	Bit 2	Bit 1	Bit 0
VCO current Calibration	R	--	--	--	VCCF	VCB3	VCB2	VCB1	VCB0
	W	ROSCS	RSIS	VCRLS	MVCS	VCOC3	VCOC2	VCOC1	VCOC0

**ROSCS: WOR RC select. Recommend ROSCS = [1]**

**RSIS: WOR current select. Recommend RSIS = [0]**

**VCRLS: VCO Current Resistor Select. Recommend VCRLS = [0]**

[0]: low current select. [1]: high current select.

**MVCS: VCO current calibration value select. Recommend MVCS = [0].**

[0]: Auto calibration value. [1]: Manual calibration value.

**VCOC [3:0]: VCO current manual calibration value.**

**VCCF: VCO Current Auto Calibration Flag (read only).**

[0]: Pass. [1]: Fail.

**VCB [3:0]: VCO current calibration value (read only).**

MVCS= 0: Auto calibration value (VCB).

MVCS= 1: Manual calibration value (VCOC).

### 9.2.39 VCO band Calibration Register I (Address: 26h)

Name	R/W	Bit 7	Bit 6	Bit 5	Bit 4	Bit 3	Bit 2	Bit 1	Bit 0
VCO Single band Calibration I	R	--	--	--	--	VBCF	VB2	VB1	VB0
	W	DCD1	DCD0	DAGS	CWS	MVBS	MVB2	MVB1	MVB0

**DCD [1:0]: VCO Deviation Calibration Delay. Recommend DCD = [11].**

Delay time = PDL (Delay Register I, 17h) × ( DDC + 1 ).

**DAGS: DAG Calibration Value Select. Recommend DAGS = [0].**

[0]: Auto calibration value. [1]: Manual calibration value.

**CWS: Clock Disable for VCO Modulation. Recommend CWS = [1].**  
 [0]: Enable. [1]: Disable.

**MVBS: VCO bank calibration value select. Recommend MVBS = [0].**  
 [0]: Auto calibration value. [1]: Manual calibration value.

**MVB [2:0]: VCO band manual calibration value.**

**VBCF: VCO band auto calibration flag (read only).**  
 [0]: Pass. [1]: Fail.

**VB [2:0]: VCO bank calibration value (read only).**  
 MVBS= 0: Auto calibration value (AVB).  
 MVBS= 1: Manual calibration value (MVB).

### 9.2.40 VCO band Calibration Register II (Address: 27h)

Name	R/W	Bit 7	Bit 6	Bit 5	Bit 4	Bit 3	Bit 2	Bit 1	Bit 0
VCO Single band Calibration II	W	DAGM7	DAGM6	DAGM5	DAGM4	DAGM3	DAGM2	DAGM1	DAGM0
	R	DAGB7	DAGB6	DAGB5	DAGB4	DAGB3	DAGB2	DAGB1	DAGB0

**DAGM [7:0]: DAG Manual Setting Value.**

**DAGB [7:0]: Auto DAG Calibration Value (read only).**

### 9.2.41 VCO Deviation Calibration Register I (Address: 28h)

Name	R/W	Bit 7	Bit 6	Bit 5	Bit 4	Bit 3	Bit 2	Bit 1	Bit 0
VCO Deviation Calibration I	R	DEVA7	DEVA6	DEVA5	DEVA4	DEVA3	DEVA2	DEVA1	DEVA0
	W	DEVS3	DEVS2	DEVS1	DEVS0	DAMR_M	VMTE_M	VMS_M	MSEL

**DEVS [3:0]: Deviation Output Scaling. Recommend DEVS = [0111].**

**DAMR\_M: DAMR Manual Enable. Recommend DAMR\_M = [0].**  
 [0]: Disable. [1]: Enable.

**VMTE\_M: VMT Manual Enable. Recommend VMTE\_M = [0].**  
 [0]: Disable. [1]: Enable.

**VMS\_M: VM Manual Enable. Recommend VMS\_M = [0].**  
 [0]: Disable. [1]: Enable.

**MSEL: VMS, VMTE and DAMR control select. Recommend MSEL = [0].**  
 [0]: Auto control. [1]: Manual control.

**DEVA [7:0]: Deviation Output Value (read only).**  
 MVDS (29h)= 0: Auto calibration value  $((DEVC / 8) \times (DEVS + 1))$ ,  
 MVDS (29h)= 1: Manual calibration value (DEVM [6:0]).

### 9.2.42 VCO Deviation Calibration Register II (Address: 29h)

Name	R/W	Bit 7	Bit 6	Bit 5	Bit 4	Bit 3	Bit 2	Bit 1	Bit 0
VCO Deviation Calibration II	R	DEVC7	DEVC6	DEVC5	DEVC4	DEVC3	DEVC2	DEVC1	DEVC0
	W	MVDS	DEVM 6	DEVM5	DEVM4	DEVM3	DEVM2	DEVM1	DEVM0

**MVDS: VCO Deviation Calibration Select. Recommend MVDS = [0].**  
 [0]: Auto calibration value. [1]: Manual calibration value.

**DEVM [6:0]: VCO Deviation Manual Calibration Value.**

**DEVC [7:0]: VCO Deviation Auto Calibration Value (read only).**

**9.2.43 DASP0 (Address: 2Ah, Page 0 by AGT [3:0]=0)**

Name	R/W	Bit 7	Bit 6	Bit 5	Bit 4	Bit 3	Bit 2	Bit 1	Bit 0
DASP0	W	QLIM	RFSP	INTXC (CSXTL5)	CSXTL4	CSXTL3	CSXTL2	CSXTL1	CSXTL0

**QLIM: quick charge select for IF limiter amp. Recommend QLIM = [0].**

[0]: disable. [1]: enable. (QLIM fall down delay 10 us).

**RFSP: RF single port Select. Recommend RFSP = [0].**

[0]: LNA (RFI) and PA (RFO) are combined internally to RFI pin.

[1]: LNA (RFI) and PA (RFO) are separated to RFI pin and RFO pin.

**INTXC: internal crystal oscillator capacitor selection. Recommend INTXC = [1].**

[0]: disable. [1]: enable.

**CSXTAL[4:0]: On-chip Crystal loading select. Recommend CSXTAL = [10100] if Xtal Cloud = 18 pF.**

{INTXC,CSXTAL[4:0]}	On-chip Xtal Capacitor (pF)
0XXXXX	0
100000	16
100001	17
100010	18
...	
111110	46
111111	47

**9.2.43 DASP1 (Address: 2Ah, Page 1 by AGT[3:0]=1)**

Name	R/W	Bit 7	Bit 6	Bit 5	Bit 4	Bit 3	Bit 2	Bit 1	Bit 0
DASP1	W	STS	CELS	RGS	RGC1	RGC0	VRPL1	VRPL0	INTPRC

**STS: Start up mode select. Shall be set to [0].**

**CELS: Digital voltage select in standby mode. Recommend CELS = [1].**

**RGS: Low Power Regulator Voltage Select. Recommend RGS = [0].**

LVR (2Ch)	RGS	Low Power Regulator Voltage	Note
0	0	3/5 *REG1	
0	1	3/4 * REG1	
1	0	1.8 V	Recommended
1	1	1.6 V	

**RGC [1:0]: Low power band-gap current select. Recommend RGC = [01].**

**VRPL [1:0]: internal PLL loop filter resistor value select. Recommend VRPL = [00].**

[00]: 500 ohm. [01]: 666 ohm. [10]: 1 K ohm. [11]: 2K ohm.

**INTPRC: Internal PLL loop filter resistor and capacitor select. Recommend INTPRC = [1].**

[0]: disable. [1]: enable

**9.2.43 DASP2 (Address: 2Ah, Page 2 by AGT[3:0]=2)**

Name	R/W	Bit 7	Bit 6	Bit 5	Bit 4	Bit 3	Bit 2	Bit 1	Bit 0
DASP2	W	VTRB3	VTRB2	VTRB1	VTRB0	VMRB3	VMRB2	VMRB1	VMRB0

**VTRB [3:0]: Resistor Bank for VT RC Filtering. Shall be set to [0000].**

**VMRB [3:0]: Resistor Bank for VM RC Filtering. Shall be set to [0000].**

**9.2.43 DASP3 (Address: 2Ah, Page 3 by AGT[3:0]=3)**

Name	R/W	Bit 7	Bit 6	Bit 5	Bit 4	Bit 3	Bit 2	Bit 1	Bit 0
DASP3	W	DCV7	DCV6	DCV5	DCV4	DCV3	DCV2	DCV1	DCV0

DCV [7:0]: Demodulator Fix mode DC value. Recommend DCV = [0x80].

**9.2.43 DASP4 (Address: 2Ah, Page 4 by AGT[3:0]=4)**

Name	R/W	Bit 7	Bit 6	Bit 5	Bit 4	Bit 3	Bit 2	Bit 1	Bit 0
DASP4	W/R	VMG7	VMG6	VMG5	VMG4	VMG3	VMG2	VMG1	VMG0

VMG [7:0]: VM Center Value for Deviation Calibration. Recommend VMG [7:0] = [0x80].

**9.2.43 DASP5 (Address: 2Ah, Page 5 by AGT[3:0]=5)**

Name	R/W	Bit 7	Bit 6	Bit 5	Bit 4	Bit 3	Bit 2	Bit 1	Bit 0
DASP5	W	--	--	PKT1	PKT0	PKS	PKIS1	PKIS0	IFPK

PKT[1:0]: VCO Peak Detect Current Select. Recommend PKT = [00].

PKS: VCO Current Calibration Mode Select. Recommend PKS = [0].

PKIS[1:0]: AGC Peak Detect Current Select. Recommend PKIS = [00].

IFPK: AGC Amplifier Current Select. Recommend IFPK = [0].

**9.2.43 DASP6 (Address: 2Ah, Page 6 by AGT[3:0]=6)**

Name	R/W	Bit 7	Bit 6	Bit 5	Bit 4	Bit 3	Bit 2	Bit 1	Bit 0
DASP6	W	--	HPLS	HRS	PACTL	IWS	CNT	MXD	LXD

HPLS: High Power LNA Gain Select. Recommend HPLS = [0].

[0]: LGC set to 6dB when in TX Mode. [1]: LGC set to 24dB when in TX Mode.

HRS: Reserved for internal usage only. Shall be set to [0].

PACTL: Reserved for internal usage only. Shall be set to [0].

IWS: Reserved for internal usage only. Shall be set to [1].

CNT: Reserved for internal usage only. Shall be set to [0].

MXD: Reserved for internal usage only. Shall be set to [1].

LXD: Reserved for internal usage only. Shall be set to [0].

**9.2.43 DASP7 (Address: 2Ah, Page 7 by AGT[3:0]=7)**

Name	R/W	Bit 7	Bit 6	Bit 5	Bit 4	Bit 3	Bit 2	Bit 1	Bit 0
DASP7	W	XDS	VRSEL	MS	MSCL4	MSCL3	MSCL2	MSCL1	MSCL0

XDS: VCO Modulation Data Sampling Clock selection. Recommend XDS = [0].

[0]: 8x over-sampling Clock. [1]: XCPCCK Clock.

VRSEL: AGC Function select. Recommend VRSEL = [1].

[0]: RSSI AGC. [1]: Normal AGC.

MS: AGC Manual scale select. Recommend MS = [0].

[0]: By (RH-RL). [1]: By MSCL[4:0].

MSCL[4:0]: AGC Manual Scale setting. Recommend MSCL = [00000].

**9.2.44 VCO Modulation Delay Register (Address: 2Bh)**

Bit	R/W	Bit 7	Bit 6	Bit 5	Bit 4	Bit 3	Bit 2	Bit 1	Bit 0
Name	W	DMV1	DMV0	DEVFD2	DEVFD1	DEVFD0	DEVD2	DEVD1	DEVD0

**DMV [1:0]: Demodulator D/A Voltage Range Select. Recommend DMV = [11].**

[00]: 1/32\*1.2. [01]: 1/16\*1.2. [10]: 1/8\*1.2. [11]: 1/4\*1.2.

**DEVFD [2:0]: VCO Modulation Data Delay by 8x over-sampling Clock. Recommend DEVFD = [011].**

**DEVD [2:0]: VCO Modulation Data Delay by XCPCK Clock. Recommend DEVD = [100].**

### 9.2.45 Battery detect Register (Address: 2Ch)

Name	R/W	Bit 7	Bit 6	Bit 5	Bit 4	Bit 3	Bit 2	Bit 1	Bit 0
Battery detect	W	LVR	RGV1	RGV0	QDS	BVT2	BVT1	BVT0	BD_E
	R	--	RGV1	RGV0	BDF	BVT2	BVT1	BVT0	BD_E

**LVR: Low Power Bandgap Select. Recommend LVR = [1].**

[0]: Disable. [1]: Enable.

**RGV [1:0]: VDD\_D and VDD\_A voltage setting in non-Sleep mode. Recommend RGV = [11].**

[00]: 2.1V. [01]: 2.0V. [10]: 1.9V. [11]: 1.8V.

**QDS: VDD Quick Discharge Select. Recommend QDS = [1].**

[0]: Disable. [1]: Enable.

**BVT [2:0]: Battery voltage detect threshold.**

[000]: 2.0V. [001]: 2.1V. [010]: 2.2V. [011]: 2.3V.

[100]: 2.4V. [101]: 2.5V. [110]: 2.6V. [111]: 2.7V.

**BD\_E: Battery Detect Enable.**

[0]: Disable. [1]: Enable. It will be clear after battery detection is triggered.

**BDF: Battery detection flag.**

[0]: Battery voltage < BVT [2:0]. [1]: Battery voltage  $\geq$  BVT [2:0].

### 9.2.46 TX test Register (Address: 2Dh)

Name	R/W	Bit 7	Bit 6	Bit 5	Bit 4	Bit 3	Bit 2	Bit 1	Bit 0
TX test	W	RMP1	RMP0	TXCS	PAC1	PAC0	TBG2	TBG1	TBG0

**RMP [1:0]: PA ramp up timing scale. Recommend RMP = [00].**

**TXCS: TX Current Setting. Recommend TXCS = [1].**

[0]: lowest current. [1]: highest current.

**PAC [1:0]: PA Current Setting.**

**TBG [2:0]: TX Buffer Setting.**

RF Band	Typical power (dBm)	PWORS (24h)	TBG	TXCS	PAC	Typical current (mA)
2.4GHz	5	1	7	1	2	29
	0	1	0	1	0	20
	-5	0	4	1	0	18
	-17	0	0	1	0	16

Refer to A7130 App. Note for more settings.

### 9.2.47 Rx DEM test Register I (Address: 2Eh)

Name	R/W	Bit 7	Bit 6	Bit 5	Bit 4	Bit 3	Bit 2	Bit 1	Bit 0
Rx DEM test I	W	DMT	DCM1	DCM0	MLP1	MLP0	SLF2	SLF1	SLF0

**DMT: Reserved for internal usage only. Shall be set to [0].**

**DCM [1:0]: Demodulator DC estimation mode. Recommend DCM = [10].**

(The average length before hold is selected by DCL in RX DEM Test Register II.)

[00]: Fix mode (For testing only). DC level is set by DCV [7:0].



[01]: Preamble hold mode. DC level is preamble average value.  
 [10]: ID hold mode. DC level is the average value hold about 8 bit data rate later if preamble is detected.  
 [11]: Payload average mode (For internal usage). DC level is payload data average.

**MLP1: Reserved for internal usage. Shall set MLP1 = [0].**

**MLP0: Reserved for internal usage. Shall set MLP0 = [0].**

**SLF [2:0]: Symbol Recovery Loop Filter Setting. Shall be SLF[2:0] = [111].**

#### 9.2.48 Rx DEM test Register II (Address: 2Fh)

Name	R/W	Bit 7	Bit 6	Bit 5	Bit 4	Bit 3	Bit 2	Bit 1	Bit 0
Rx DEM test II	W	DCH1	DCH0	DCL2	DCL1	DCL0	RAW	CDTM1	CDTM0

**DCH [1:0]: DC Estimation of AGC hold mode. Recommend DCH = [11].**

[00]: hold when PMDO. [01]: hold when Fsync. [10]: no hold. [11]: no hold.

**DCL [2]: DC Estimation Average Length After ID Detected. Recommend DCL[2] = [1].**

[0]: 128 bits. [1]: 256 bits.

**DCL [1:0]: DC Estimation Average Length Before ID Detected. Recommend DCL[1:0] = [10].**

[00]: 8 bits. [01]: 16 bits. [10]: 32 bits. [11]: 64 bits.

**RAW: Raw Data Output Select. Recommend RAW = [1].**

[0]: latch data output. [1]: RAW data output.

**CDTM [1:0]: Preamble carrier detect setting. Recommend CDTM = [11].**

[00]: 12. [01]: 24. [10]: 36. [11]: 48.

#### 9.2.49 Charge Pump Current Register I (Address: 30h)

Name	R/W	Bit 7	Bit 6	Bit 5	Bit 4	Bit 3	Bit 2	Bit 1	Bit 0
CPC I	W	CPM3	CPM2	CPM1	CPM0	CPT3	CPT2	CPT1	CPT0

**CPM [3:0]: Charge Pump Current Setting for VM loop. Recommend CPM = [1111].**

Charge pump current = (CPM + 1) / 16 mA.

**CPT [3:0]: Charge Pump Current Setting for VT loop. Recommend CPT = [0000].**

Charge pump current = (CPT + 1) / 16 mA.

#### 9.2.50 Charge Pump Current Register II (Address: 31h)

Name	R/W	Bit 7	Bit 6	Bit 5	Bit 4	Bit 3	Bit 2	Bit 1	Bit 0
CPC II	W	CPTX3	CPTX2	CPTX1	CPTX0	CPRX3	CPRX2	CPRX1	CPRX0

**CPTX [3:0]: Charge Pump Current Setting for TX mode. Recommend CPTX = [0011].**

Charge pump current = (CPTX + 1) / 16 mA.

**CPRX [3:0]: Charge Pump Current Setting for RX mode. Recommend CPRX = [0111].**

Charge pump current = (CPRX + 1) / 16 mA.

#### 9.2.51 Crystal test Register (Address: 32h)

Name	R/W	Bit 7	Bit 6	Bit 5	Bit 4	Bit 3	Bit 2	Bit 1	Bit 0
Crystal test	W	CDPM	CPS	CPH	CPCS	DBD	XCC	XCP1	XCP0

**CDPM: First Time Preamble Detect mode select. Recommend CDPM = [0].**

**CPS: PLL charge pump enable. Recommend CPS = [1].**

[0]: Enable. [1]: Disable.

**CPH: Charge Pump High Current. Shall be set to [0].**

[0]: Normal. [1]: High.

**CPCS: Charge Pump Current Select. Shall be set to [1].**

[0]: Use CPM for TX, CPT for RX. [1]: Use CPTX for TX, CPRX for RX.

**DBD: Crystal Frequency Doubler High Level Pulse Width Select. Recommend DBD = [0].**

[0]: about 8 ns. [1]: about 16 ns.

**XCC: Crystal Startup Current Selection. Recommend XCC = [1].**

[0]: about 0.7 mA. [1]: about 1.5 mA.

**XCP [1:0]: Crystal Oscillator Regulated Couple Setting. Recommend XCP = [01].**

[00]: 1.5mA. [01]: 0.5mA. [10]: 0.35mA. [11]: 0.3mA.

### 9.2.52 PLL test Register (Address:33h)

Name	R/W	Bit 7	Bit 6	Bit 5	Bit 4	Bit 3	Bit 2	Bit 1	Bit 0
PLL test	W	MDEN	OLM	PRIC1	PRIC0	PRRC1	PRRC0	SDPW	NSDO

**MDEN : Use for Manual VCO Calibration. Shall be set to [0].**

**OLM: Open Loop Modulation Enable. Shall be set to [0].**

[0]: Disable. [1]: Enable.

**PRIC [1:0]: Prescaler IF Part Current Setting. Shall be set to [01].**

[00]: 0.95mA. [01]: 1.05mA. [10]: 1.15mA. [11]: 1.25mA.

**PRRC [1:0]: Prescaler RF Part Current Setting. Shall be set to [01].**

[00]: 1.0mA. [01]: 1.2mA. [10]: 1.4mA. [11]: 1.6mA.

**SDPW: Clock Delay For Sigma Delta Modulator. Shall be set to [0].**

[0]: 13 ns. [1]: 26 ns.

**NSDO: Sigma Delta Order Setting. Shall be set to [1].**

[0]: order 2. [1]: order 3.

### 9.2.53 VCO test Register I (Address:34h)

Name	R/W	Bit 7	Bit 6	Bit 5	Bit 4	Bit 3	Bit 2	Bit 1	Bit 0
VCO test I	W	DEVGD2	DEVGD1	DEVGD0	TLB1	TLB0	RLB1	RLB0	VBS

**DEVGD [2:0]: Sigma Delta Modulator Data Delay Setting. Recommend DEVGD = [000].**

**TLB [1:0]: LO Buffer Current Select. Recommend TLB[1:0] = [10].**

[00]: 0.6mA. [01]: 0.75mA. [10]: 0.9mA. [11]: 1.05mA.

**RLB [1:0]: RF divider Current Select. Recommend RLB[1:0] = [10].**

[00]: 1.2mA. [01]: 1.5mA. [10]: 1.8mA. [11]: 2.1mA.

**VBCS : VCO Buffer Current Setting. Recommend VBCS = [1].**

[0]: 1mA. [1]: 1.5mA.

### 9.2.54 RF Analog Test Register (Address: 35h)

Name	R/W	Bit 7	Bit 6	Bit 5	Bit 4	Bit 3	Bit 2	Bit 1	Bit 0
RFT	W	AGT3	AGT2	AGT1	AGT0	RFT3	RFT2	RFT1	RFT0

**AGT[3:0]:Page selection for both DASP (2Ah) and ROMP (38h).**

AGT[3:0] (35h)	DASP Register Group (2Ah)	ROMP Register Group (38h)	Note
0	DASP0 (page 0)	ROMP0 (page 0)	Internal usage only
1	DASP1 (page 1)	ROMP1 (page 1)	Internal usage only
2	DASP2 (page 2)	ROMP2 (page 2)	Internal usage only
3	DASP3 (page 3)	ROMP3 (page 3)	Internal usage only
4	DASP4 (page 4)	ROMP4 (page 4)	Internal usage only
5	DASP5 (page 5)		
6	DASP6 (page 6)		

RFT [3:0]: RF analog pin configuration for testing. Recommend RFT= [0000].

### 9.2.55 AES Key data Register (Address: 36h)

Name	R/W	Bit 7	Bit 6	Bit 5	Bit 4	Bit 3	Bit 2	Bit 1	Bit 0
Key Data	R	KEYO7	KEYO6	KEYO5	KEYO4	KEYO3	KEYO2	KEYO1	KEYO0
	W	KEYI7	KEYI6	KEYI5	KEYI4	KEYI3	KEYI2	KEYI1	KEYI0

KEYI [7:0]: AES128 key input, total 16-bytes. (Write only).

KEYO [7:0]: AES128 key output, total 16-bytes. (Read only). Select by KEYOS (3Eh).

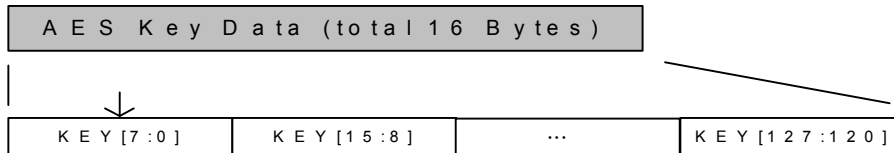

### 9.2.56 Channel Select Register (Address: 37h)

Name	R/W	Bit 7	Bit 6	Bit 5	Bit 4	Bit 3	Bit 2	Bit 1	Bit 0
Channel Select	W	CHI3	CHI2	CHI1	CHI0	CHD3	CHD2	CHD1	CHD0

CHI [3:0]: Auto IF Offset Channel Number Setting. Recommend CHI [3:0] = [0111].

$$F_{\text{CHSP}} \times (\text{CHI} + 1) = F_{\text{IF}}$$

Refer to chapter 14 for  $F_{\text{CHSP}}$  setting.

CHD [3:0]: Channel Frequency Offset for Deviation Calibration. Recommend CHD [3:0] = [0111].

Offset channel number = +/- (CHD + 1).

### 9.2.57 ROMP0 (Address: 38h, Page 0 by AGT[3:0]=0)

Name	R/W	Bit 7	Bit 6	Bit 5	Bit 4	Bit 3	Bit 2	Bit 1	Bit 0
ROMP0	W	MPOR	EPRG	MIGS	MRGS	MRSS	MTMS	MADS	MBGS

MPOR: manual SPI read in OTP program cycle.

EPRG: enable OTP program in test mode.

[0]: disable. [1]: enable.

MIGS: IF gain setting select.

[0]: SPI setting. [1]: OTP setting.

MRGS: LNA and mixer gain setting select.

[0]: SPI setting. [1]: OTP setting.

MRSS: RSSI voltage fine trim setting select.

[0]: SPI setting. [1]: OTP setting.

MTMS: Temp voltage fine trim setting select.

[0]: SPI setting. [1]: OTP setting.

MADS: ADC fine trim setting select.

[0]: SPI setting. [1]: OTP setting.

MBGS: Bandgap voltage fine trim setting select.

[0]: SPI setting. [1]: OTP setting.

### 9.2.57 ROMP1 (Address: 38h, Page 1 by AGT[3:0]=1)

Name	R/W	Bit 7	Bit 6	Bit 5	Bit 4	Bit 3	Bit 2	Bit 1	Bit 0
ROMP1	W	APG	MPA1	MPA0	FBG4	FBG3	FBG2	FBG1	FBG0

APG: OTP program select.

[1]: auto program. [0]: manual SPI setting.

MPA [1:0]: OPT address setting in manual SPI OTP program.

FBG [4:0]: Bandgap voltage SPI fine trim setting.

### 9.2.57 ROMP2 (Address: 38h, Page 2 by AGT[3:0]=2)

Name	R/W	Bit 7	Bit 6	Bit 5	Bit 4	Bit 3	Bit 2	Bit 1	Bit 0
ROMP2	W	PTM1	PTM0	CTR5	CTR4	CTR3	CTR2	CTR1	CTR0

PTM [1:0]: OTP program operation mode select. Recommend PTM = [00].

CTR [5:0]: ADC voltage SPI fine trim setting.

### 9.2.57 ROMP3 (Address: 38h, Page 3 by AGT[3:0]=3)

Name	R/W	Bit 7	Bit 6	Bit 5	Bit 4	Bit 3	Bit 2	Bit 1	Bit 0
ROMP3	W	FGC1	FGC0	CRS2	CRS1	CRS0	SRS2	SRS1	SRS0

FGC[1:0]: BPF fine gain control.

CRS [2:0]: RSSI voltage offset fine trim setting.

SRS [2:0]: RSSI voltage curve slope fine time setting.

### 9.2.57 ROMP4 (Address: 38h, Page 4 by AGT[3:0]=4)

Name	R/W	Bit 7	Bit 6	Bit 5	Bit 4	Bit 3	Bit 2	Bit 1	Bit 0
ROMP4	W	--	STMP	STM5	STM4	STM3	STM2	STM1	STM0

STMP: Temp voltage ADC reading select.

[0]: 1 scale / degree C. [1]: 2 scale/degree C.

STM [5:0]: Temperature voltage SPI fine trim setting.

### 9.2.58 Data Rate Clock Register (Address: 39h)

Name	R/W	Bit 7	Bit 6	Bit 5	Bit 4	Bit 3	Bit 2	Bit 1	Bit 0
Data Rate Clock	W	SDR7	SDR6	SDR5	SDR4	SDR3	SDR2	SDR1	SDR0

SDR [1:0]: Data Rate Setting. On-air Data rate =  $F_{IF} / (SDR+1)$ .

Data Rate	$F_{IF}$ (Hz)	SDR [7:0]	Xtal
4M	4M	0x00	16 MHz

Please refer to chapter 13 for details.

### 9.2.59 FCR Register (Address: 3Ah)

Name	R/W	Bit 7	Bit 6	Bit 5	Bit 4	Bit 3	Bit 2	Bit 1	Bit 0
FCR	R	ARTEF	VPOAK	RCR3	RCR2	RCR1	RCR0	EAK	EAR
	W	FCL1	FCL0	ARC3	ARC2	ARC1	ARC0	EAK	EAR

FCL [1:0] : FCB Length.

[00]: No Frame Control.

[01]: 1 byte FCB (3Dh).

[10]: 2 byte FCB (3Dh).

[11]: 4 byte FCB (3Dh).

Please refer to chapter 16 and 19 for details.

ARC [3:0] : Auto Resend Cycle Setting.

[0000]: resend disable.

[0001]: 1 [0010]: 2 [0011]: 3 [0100]: 4 [0101]: 5 [0110]: 6 [0111]: 7 [1000]: 8 [1001]: 9 [1010]: 10  
 [1011]: 11 [1100]: 12 [1101]: 13 [1110]: 14 [1111]: 15

**EAK : Enable Auto ACK.**

[0]: Disable. [1]: Enable.

**EAR : Enable Auto Resend.**

[0]: Disable. [1]: Enable.

**ARTEF: Auto re-transmission ending flag (read only).**

[0]: Resend not end [1]: Finish resend.

**VPOAK : Valid Packet or ACK OK Flag. (read only and auto clear by Strobe command)**

[0]: Neither valid packet nor ACK OK. [1]: Valid packet or ACK OK.

**RCR [3:0] (read) : Decrement of ARC[3:0].**

Please refer to chapter 16 and 19 for details.

### 9.2.60 ARD Register (Address: 3Bh)

Name	R/W	Bit 7	Bit 6	Bit 5	Bit 4	Bit 3	Bit 2	Bit 1	Bit 0
ARD	W	ARD7	ARD6	ARD5	ARD4	ARD3	ARD2	ARD1	ARD0

**ARD[7:0] : Auto Resend Delay**

ARD Delay = 200 us \* (ARD+1) → (200us ~ 51.2 ms)

[0000-0000]: 200 us.

[0000-0001]: 400 us.

[0000-0010]: 600 us.

...

...

[1111-1111]: 51.2 ms.

Please refer to chapter 19 for details.

### 9.2.61 AFEP Register (Address: 3Ch)

Name	R/W	Bit 7	Bit 6	Bit 5	Bit 4	Bit 3	Bit 2	Bit 1	Bit 0
AFEP	R	0	0	EARTS2	EARTS1	EARTS0	SID2	SID1	SID0
	W	EAF	SPSS ACKFEP5	ACKFEP4	ACKFEP3	ACKFEP2	ACKFEP1	ACKFEP0	

**EAF: Enable ACK FIFO.**

[0]: Disable. [1]: Enable.

**SPSS : Mode Back Select for Auto ACK/Resend.**

[0]: Standby mode. [1]: PLL mode.

**ACKFEP [5:0]: FIFO Length setting for auto-ack packet.**

ACK FIFO Length = (ACKFEP[5:0] + 1)

max. 64 bytes.

**EARTS [2:0]: Enable Auto Resend Read.**

**SID [2:0]: Serial Packet ID.**

This device increases SID each time for every new packet and keep the same SID when retransmitting.

Please refer to chapter 16 and 19 for details.

### 9.2.62 FCB Register (Address: 3Dh)

Name	R/W	Bit 7	Bit 6	Bit 5	Bit 4	Bit 3	Bit 2	Bit 1	Bit 0
FCB	R/W	F7	F6	F5	F4	F3	F2	F1	F0

**FCB [7:0]: Frame Control Buffer, total 20-bytes.**

Byte	Name	Bit-Map	Description	Strobe Cmd
0	FCB0	0   0   1   1   1   SID2   SID1   SID0	For auto-resend.	NA
1	FCB1	[7:0]	ACK info by user's attaching	NA
2	FCB2	[7:0]		
3	FCB3	[7:0]		

Remark:

1. Please refer to section **10.4.10** for details.
2. SID is auto incremental for every new packet if FCB0 is enabled.
3. FCB0 ~ FCB3 is controlled by FCL[1:0] (3Ah)
4. User can attach wanted ACK information to FCB1 ~ FCB3 if auto-ack is enabled (EAK =1).

Please refer to chapter 16 and 19 for details.

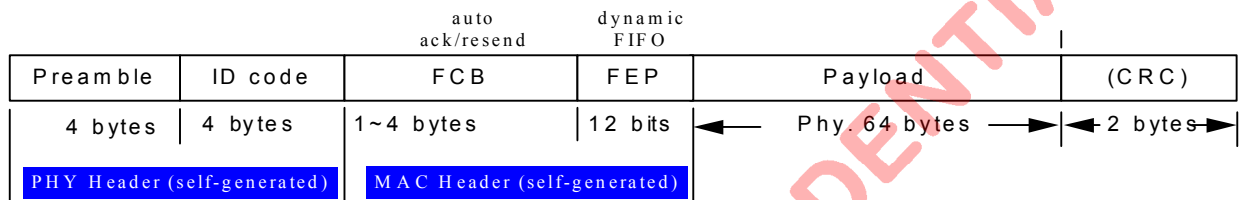

### 9.2.63 KEYC Register (Address: 3Eh)

Name	R/W	Bit 7	Bit 6	Bit 5	Bit 4	Bit 3	Bit 2	Bit 1	Bit 0
<b>KEYC</b>	W	KEYOS	AFIDS	ARTMS	MIDS	AESS	--	AKFS	EDCRS

**KEYOS: AES128 Key source read select.**

[0]: If AKFS=1, from RX received encrypted AES128 key data.  
If AKFS=0, from SPI write AES128 key data.

[1]: From encrypted/decrypted AES128 key data.  
Please refer to chapter 21 for details.

**AFIDS: FIFO ID appendixes Select.**

[0]: Disable. [1]: Enable.

**ARTMS: auto-resend Interval Mode Select.**

[0]: random interval. [1]: fixed interval.  
Please refer to chapter 16 and 19 for details.

**MIDS: FIFO control byte address mapping for FIFO ID select.**

[0]: Received device ID. [1]: internal FIFO control byte ID.

**AESS: encryption format selection.**

[1]: Standard AES 128 bit. [0]: proprietary 32 bit.  
Please refer to chapter 21 for details.

**AKFS: Data packet with decrypted key appendixes select.**

[0]: Disable. [1]: Enable.

**EDCRS: Data encrypt or decrypt select.**

[0]: Disable. [1]: Enable.

### 9.2.64 USID Register (Address: 3Fh)

Name	R/W	Bit 7	Bit 6	Bit 5	Bit 4	Bit 3	Bit 2	Bit 1	Bit 0
<b>USID</b>	W	RND7	RND6	RND5	RND4	RND3	RND2	RND1	RND0

**RND [7:0]: Random seed for auto-resend interval.**

Please refer to chapter 16 and 19 for details.

**10. SPI**

A7130 only supports one SPI interface with maximum data rate up to 15Mbps. MCU should assert SCS pin low (SPI chip select) to active accessing of A7130. Via SPI interface, user can access **control registers** and issue **Strobe command**. Figure 10.1 gives an overview of SPI access manners.

3-wire SPI (SCS, SCK and SDIO) or 4-wire SPI (SCS, SCK, SDIO and GIO1/GIO2) configuration is provided. For 3-wire SPI, SDIO pin is configured as bi-direction to be data input and output. For 4-wire SPI, SDIO pin is data input and GIO1 (or GIO2) pin is data output. In such case, GIO1S (0bh) or GIO2S (0ch) should be set to [0110].

For SPI write operation, SDIO pin is latched into A7130 at the rising edge of SCK. For SPI read operation, if input address is latched by A7130, data output is aligned at falling edge of SCK. Therefore, MCU can latch data output at the rising edge of SCK.

To control A7130's internal state machine, it is very easy to send Strobe command via SPI interface. The Strobe command is a unique command set with total 8 commands. See section 10.3, 10.4 and 10.5 for details.

	SPI chip select	Data In	Data Out
<b>3-Wire SPI</b>	SCS pin = 0	SDIO pin	SDIO pin
<b>4-Wire SPI</b>	SCS pin = 0	SDIO pin	GIO1 (GIO1S=0110) / GIO2 (GIO2S=0110)



Figure 10.1 SPI Access Manners

**10.1 SPI Format**

The first bit (A7) is critical to indicate A7130 the following instruction is “Strobe command” or “control register”. See Table 10.1 for SPI format. Based on Table 10.1, To access control registers, just set A7=0, then A6 bit is used to indicate read (A6=1) or write operation (A6=0). See Figure 10.2 (3-wire SPI) and Figure 10.3 (4-wire SPI) for details.

Address Byte (8 bits)								Data Byte (8 bits)							
CMD	R/W	Address						Data							
A7	A6	A5	A4	A3	A2	A1	A0	7	6	5	4	3	2	1	0

Table 10.1 SPI Format

**Address byte:**

**Bit 7: Command bit**  
 [0]: Control registers.  
 [1]: Strobe command.

**Bit 6: R/W bit**  
 [0]: Write data to control register.  
 [1]: Read data from control register.

**Bit [5:0]: Address of control register**

**Data Byte:**

**Bit [7:0]:** SPI input or output data, see Figure 10.2 and Figure 10.3 for details.

**10.2 SPI Timing Characteristic**

No matter 3-wire or 4-wire SPI interface is configured, the maximum SPI data rate is 10 Mbps. To active SPI interface, SCS pin must be set to low. For correct data latching, user has to take care hold time and setup time between SCK and SDIO. See Table 10.2 for SPI timing characteristic.

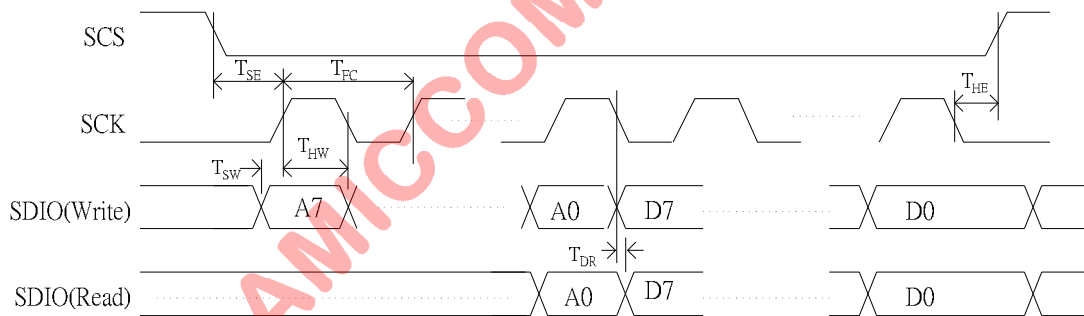

Parameter	Description	Min.	Max.	Unit
F <sub>C</sub>	FIFO clock frequency.		10	MHz
T <sub>SE</sub>	Enable setup time.	50		ns
T <sub>HE</sub>	Enable hold time.	50		ns
T <sub>SW</sub>	TX Data setup time.	50		ns
T <sub>HW</sub>	TX Data hold time.	50		ns
T <sub>DR</sub>	RX Data delay time.	0	50	ns

Table 10.2 SPI Timing Characteristic



**10.3 SPI Timing Chart**

In this section, 3-wire and 4-wire SPI interface read / write timing are described.

**10.3.1 Timing Chart of 3-wire SPI**

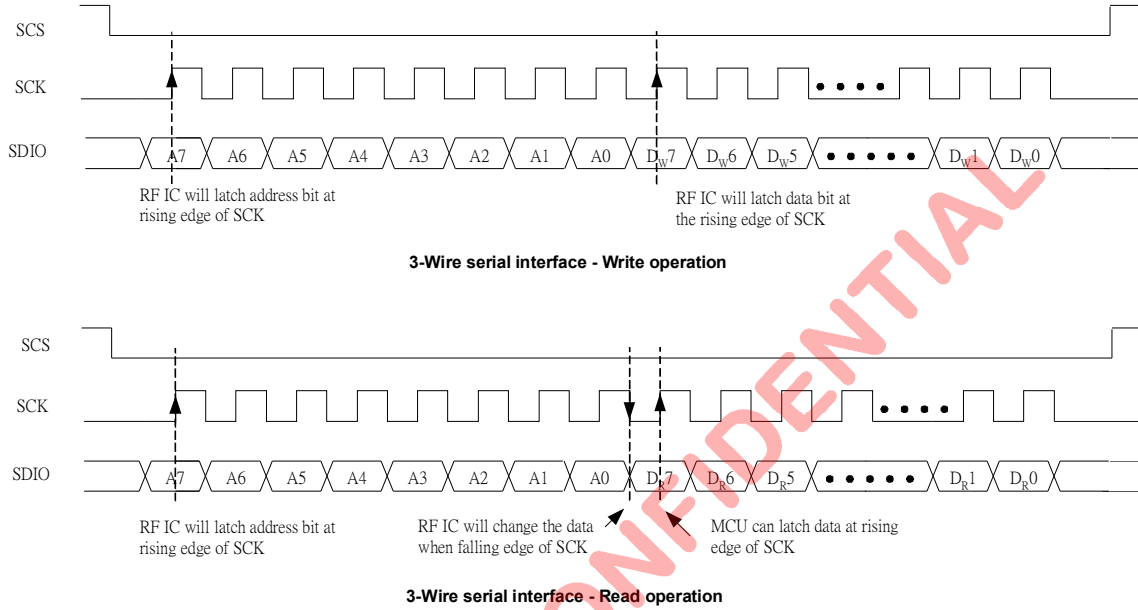

Figure 10.2 Read/Write Timing Chart of 3-Wire SPI

**10.3.2 Timing Chart of 4-wire SPI**

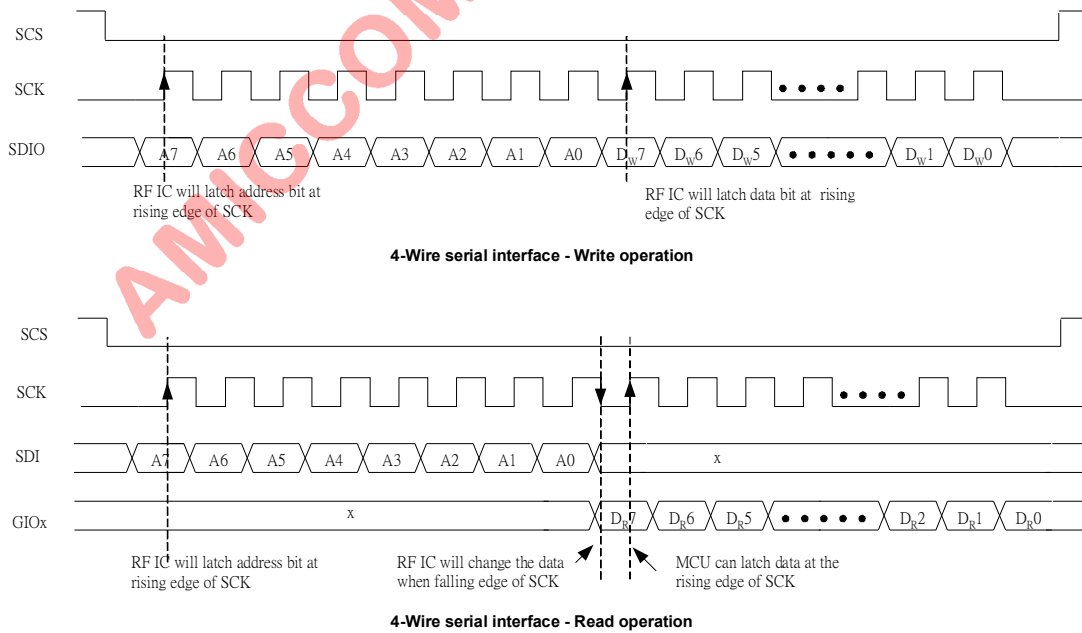

Figure 10.3 Read/Write Timing Chart of 4-Wire SPI

### 10.4 Strobe Commands

A7130 supports 8 Strobe commands to control internal state machine for chip's operations. Table 10.3 is the summary of Strobe commands.

Be notice, Strobe command could be defined by 4-bits (A7~A4) or 8-bits (A7~A0). If 8-bits Strobe command is selected, A3 ~ A0 are don't care conditions. In such case, SCS pin can be remaining low for asserting next commands.

#### Strobe Command when AFIDS =0 (3Eh) and MIDS =0 (3Eh)

Strobe Command								Description
A7	A6	A5	A4	A3	A2	A1	A0	
1	0	0	0	1	0	0	0	Deep Sleep mode (I/Os are in tri-state)
1	0	0	0	1	0	1	1	Deep Sleep mode (I/Os are pulled high)
1	0	0	0	x	x	x	x	Sleep mode
1	0	0	1	x	x	x	x	Idle mode
1	0	1	0	x	x	x	x	Standby mode
1	0	1	1	x	x	x	x	PLL mode
1	1	0	0	x	x	x	x	RX mode
1	1	0	1	x	x	x	x	TX mode
1	1	1	0	x	x	x	x	FIFO write pointer reset
1	1	1	1	x	x	x	x	FIFO read pointer reset

Remark: x means "don't care"

Table 10.3 Strobe Commands by SPI interface

#### 10.4.1 Strobe Command - Sleep Mode

Refer to Table 10.3 user can issue 4 bits (1000) Strobe command directly to set A7130 into Sleep mode. Below are the Strobe command table and timing chart.

##### Strobe Command

Strobe Command								Description
A7	A6	A5	A4	A3	A2	A1	A0	
1	0	0	0	x	x	x	x	Sleep mode

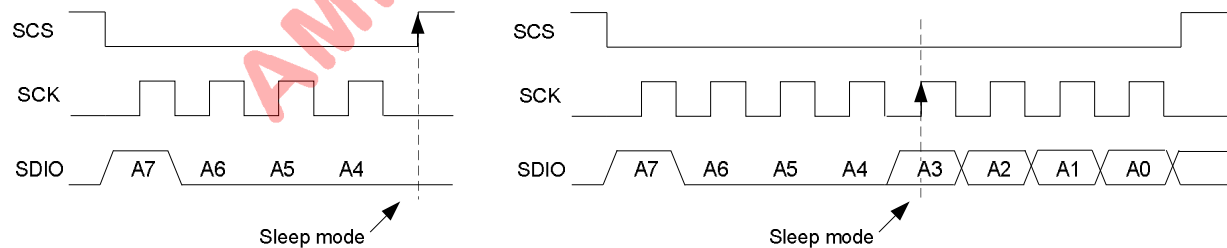

Figure 10.4 Sleep mode Command Timing Chart

#### 10.4.2 Strobe Command - Idle Mode

Refer to Table 10.3, user can issue 4 bits (1001) Strobe command directly to set A7130 into Idle mode. Below is the Strobe command table and timing chart.

**Strobe Command**

Strobe Command								Description
A7	A6	A5	A4	A3	A2	A1	A0	
1	0	0	1	x	X	x	x	Idle mode

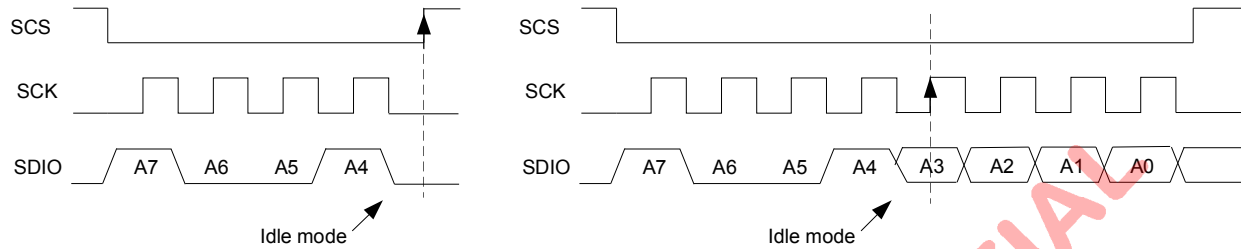

Figure 10.5 Idle mode Command Timing Chart

**10.4.3 Strobe Command - Standby Mode**

Refer to Table 10.3, user can issue 4 bits (1010) Strobe command directly to set A7130 into Standby mode. Below is the Strobe command table and timing chart.

**Strobe Command**

Strobe Command								Description
A7	A6	A5	A4	A3	A2	A1	A0	
1	0	1	0	x	X	x	x	Standby mode

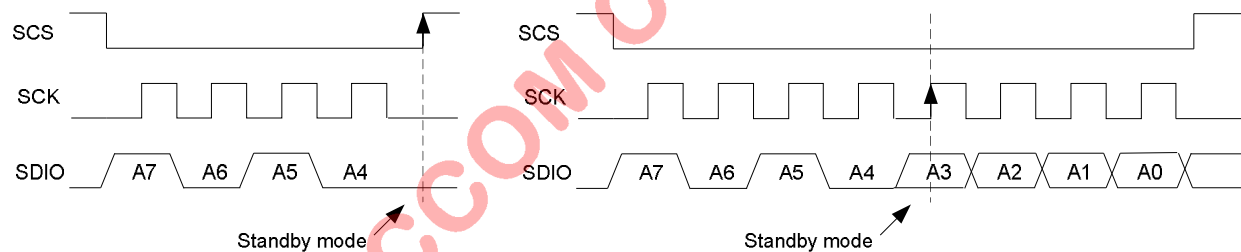

Figure 10.6 Standby mode Command Timing Chart

**10.4.4 Strobe Command - PLL Mode**

Refer to Table 10.3, user can issue 4 bits (1011) Strobe command directly to set A7130 into PLL mode. Below are the Strobe command table and timing chart.

**Strobe Command**

Strobe Command								Description
A7	A6	A5	A4	A3	A2	A1	A0	
1	0	1	1	x	X	x	x	PLL mode

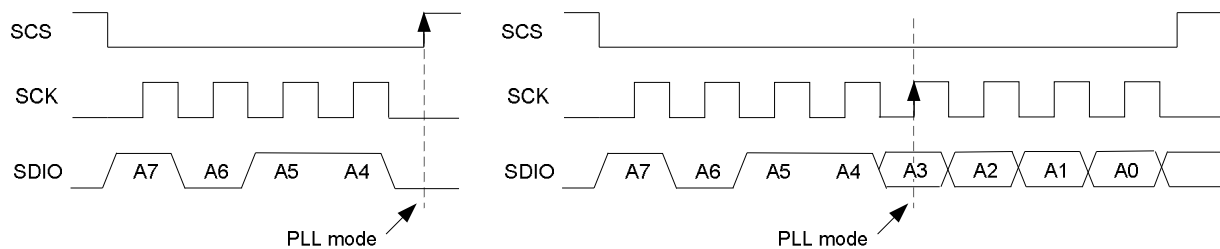

Figure 10.7 PLL mode Command Timing Chart

### 10.4.5 Strobe Command - RX Mode

Refer to Table 10.3, user can issue 4 bits (1100) Strobe command directly to set A7130 into RX mode. Below are the Strobe command table and timing chart.

#### Strobe Command

Strobe Command								Description
A7	A6	A5	A4	A3	A2	A1	A0	
1	1	0	0	x	X	x	x	RX mode

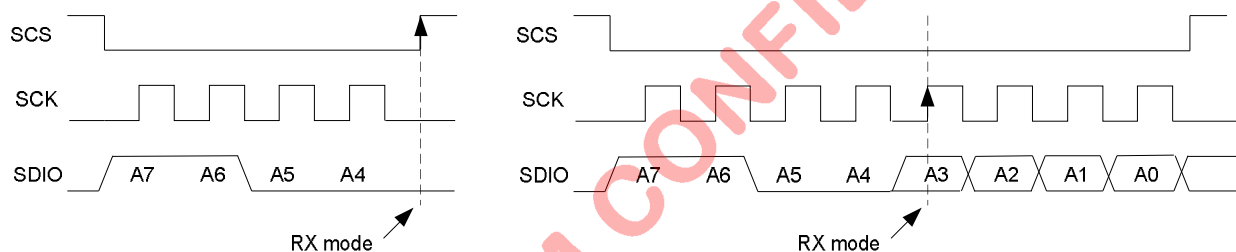

Figure 10.8 RX mode Command Timing Chart

### 10.4.6 Strobe Command - TX Mode

Refer to Table 10.3, user can issue 4 bits (1101) Strobe command directly to set A7130 into TX mode. Below are the Strobe command table and timing chart.

#### Strobe Command

Strobe Command								Description
A7	A6	A5	A4	A3	A2	A1	A0	
1	1	0	1	x	x	x	x	TX mode

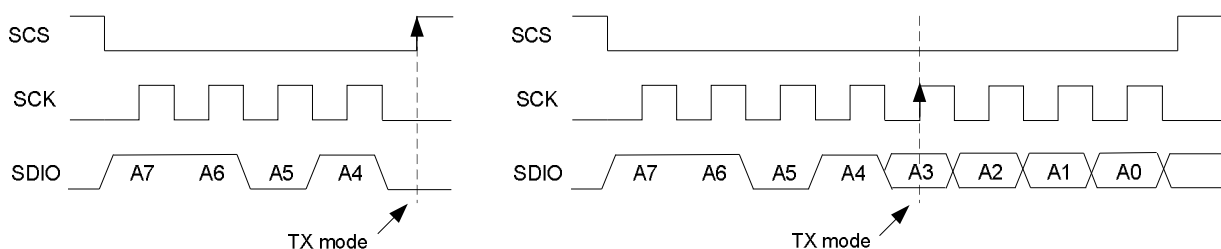

Figure 10.9 TX mode Command Timing Chart

### 10.4.7 Strobe Command – FIFO Write Pointer Reset

Refer to Table 10.3, user can issue 4 bits (1110) Strobe command directly to reset A7130 FIFO write pointer. Below is the Strobe command table and timing chart.

### Strobe Command

Strobe Command								Description
A7	A6	A5	A4	A3	A2	A1	A0	
1	1	1	0	x	x	x	x	FIFO write pointer reset

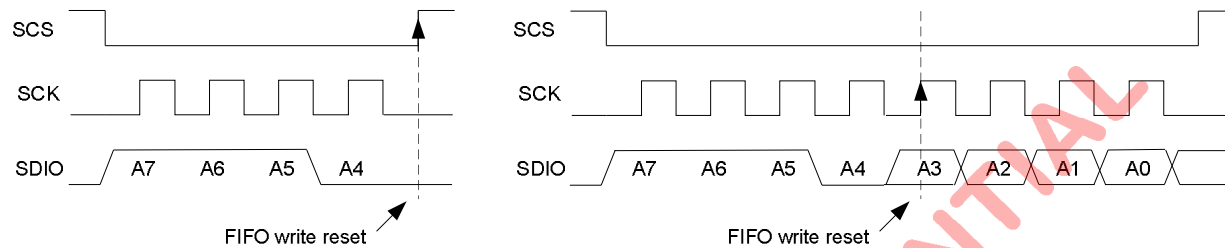

Figure 10.10 FIFO write pointer reset Command Timing Chart

### 10.4.8 Strobe Command – FIFO Read Pointer Reset

Refer to Table 10.3, user can issue 4 bits (1111) Strobe command directly to reset A7130 FIFO read pointer. Below are the Strobe command table and timing chart.

### Strobe Command

Strobe Command								Description
A7	A6	A5	A4	A3	A2	A1	A0	
1	1	1	1	x	x	x	x	FIFO read pointer reset

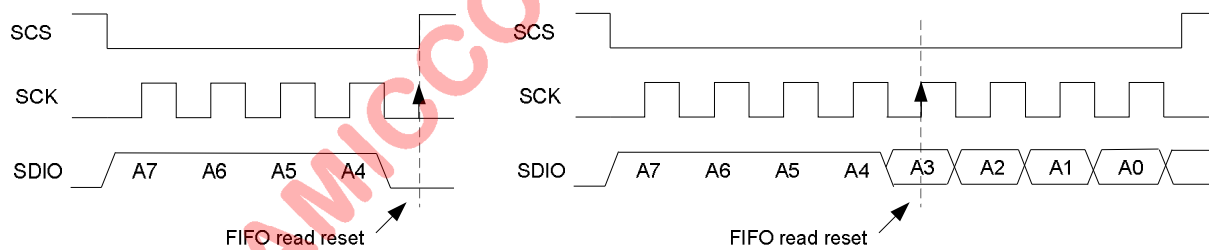

Figure 10.11 FIFO read pointer reset Command Timing Chart

### 10.4.9 Strobe Command – Deep Sleep Mode

Refer to Table 10.3, user can issue (8 bits) deep sleep Strobe command directly to switch off power supply to A7130. In this mode, A7130 is staying minimum current consumption. All registers are no data retention and re-calibration flow is necessary. Below are the Strobe command table and timing chart.

### Strobe Command

Strobe Command								Description
A7	A6	A5	A4	A3	A2	A1	A0	
1	0	0	0	1	0	0	0	Tri-state of GIO1 / GIO2 (no register retention)
1	0	0	0	1	0	1	1	Internal Pull-High of GIO1 / GIO2 (no register retention)

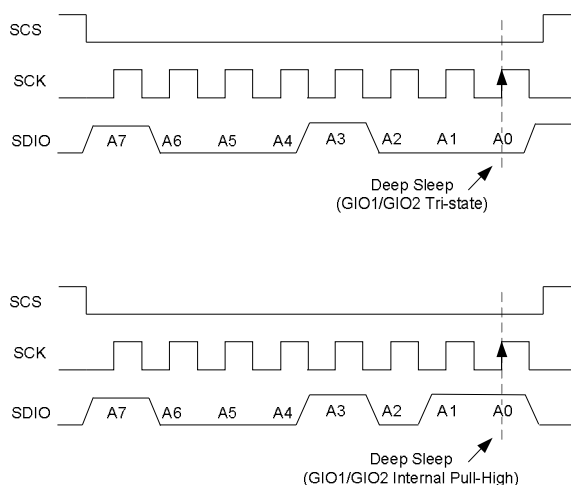

Figure 10.12 Deep Sleep Mode Timing Chart

### 10.5 Reset Command

In addition to power on reset (POR), MCU could issue software reset to A7130 by setting Mode Register (00h) through SPI interface as shown below. As long as 8-bits address (A7~A0) are delivered zero and data (D7~D0) are delivered zero, A7130 is informed to generate internal signal “RESETN” to initial itself. After reset command, A7130 is in standby mode and calibration procedure shall be issued again.

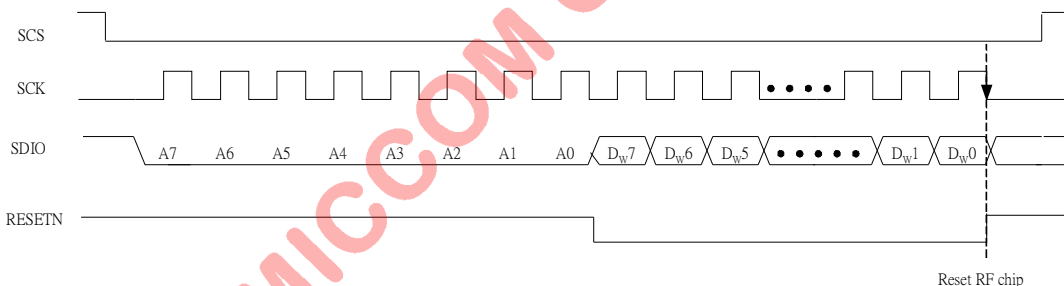

Figure 10.14 Reset Command Timing Chart

### 10.6 ID Accessing Command

A7130 has built-in 32-bits ID Registers for customized identification code. It is accessed via SPI interface. ID length is recommended to be 32 bits by setting IDL (1Fh). Therefore, user can toggle SCS pin to high to terminate ID accessing command when ID data is output completely.

Figure 10.13 and 10.14 are timing charts of 32-bits ID accessing via 3-wire SPI.

#### 10.6.1 ID Write Command

User can refer to Figure 10.2 for SPI write timing chart in details. Below is the procedure of ID write command.

- Step1: Deliver A7~A0 = 00000110 (A6=0 for write, A5~A0 = 000110 for ID addr, 06h).
- Step2: By SDIO pin, deliver 32-bits ID into A7130 in sequence by Data Byte 0 (**recommend 5xh or Axh**), 1, 2 and 3.
- Step3: Toggle SCS pin to high when step2 is completed.

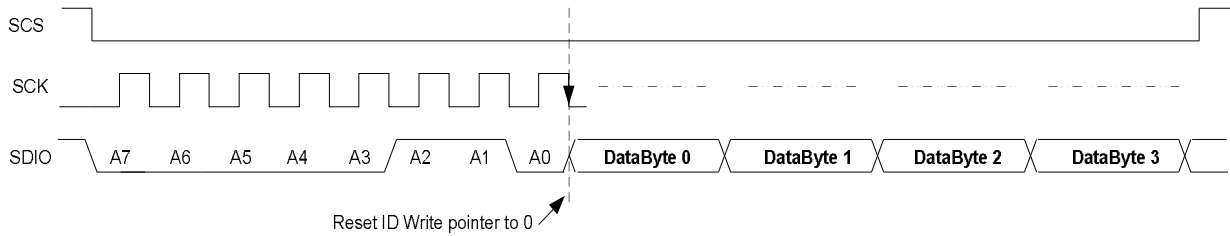

Figure 10.15 ID Write Command Timing Chart

### 10.6.2 ID Read Command

User can refer to Figure 10.2 for SPI read timing chart in details. Below is the procedure of ID read command.

- Step1: Deliver A7~A0 = 01000110 (A6=1 for read, A5~A0 = 000110 for ID addr, 06h).
- Step2: SDIO pin outputs 32-bits ID in sequence by Data Byte 0, 1, 2 and 3.
- Step3: Toggle SCS pin to high when step2 is completed.

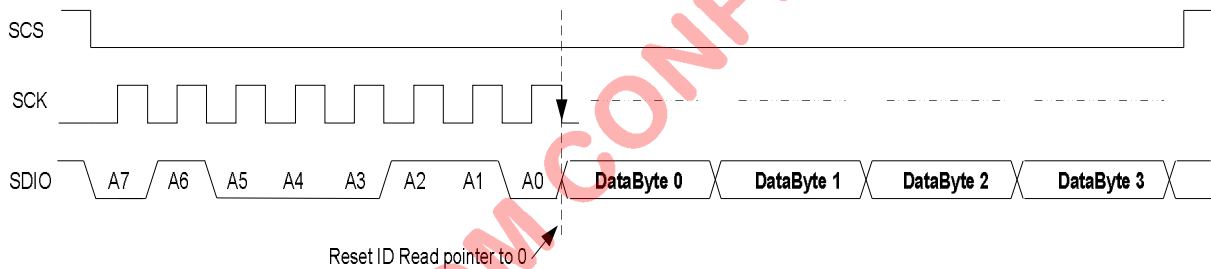

Figure 10.16 ID Read Command Timing Chart

## 10.7 FIFO Accessing Command

To use A7130's FIFO mode, enable FMS (01h) =1 via SPI interface. Before TX delivery, just write wanted data into TX FIFO (05h) then issue TX Strobe command. Similarly, user can read RX FIFO (05h) once payload data is received.

MCU can use polling or interrupt scheme to do FIFO accessing. FIFO status can output to GIO1 (or GIO2) pin by setting GIO1S (0Bh) or GIO2S (0Ch).

Figure 10.15 and 10.16 are timing charts of FIFO accessing via 3-wire SPI.

### 10.7.1 TX FIFO Write Command

User can refer to Figure 10.2 for SPI write timing chart in details. Below is the procedure of TX FIFO write command.

- Step1: Deliver A7~A0 = 00000101 (A6=0 for write control register and issue FIFO A [5:0] = 05h).
- Step2: By SDIO pin, deliver (n+1) bytes TX data into TX FIFO in sequence by Data Byte 0, 1, 2 to n.
- Step3: Toggle SCS pin to high when step2 is completed.
- Step4: Send Strobe command of TX mode (Figure 10.9) to do TX delivery.

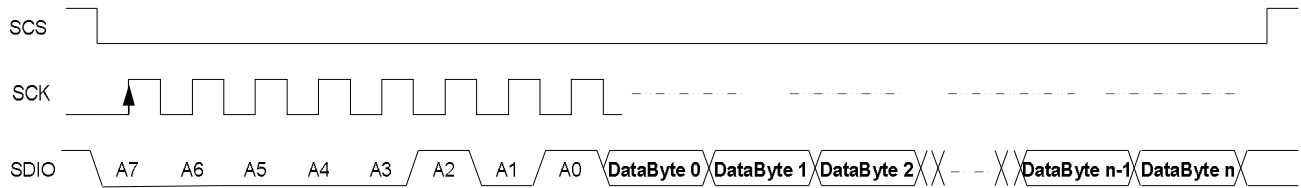

Figure 10.17 TX FIFO Write Command Timing Chart

### 10.7.2 Rx FIFO Read Command

User can refer to Figure 10.2 for SPI read timing chart in details. Below is the procedure of RX FIFO read command.

- Step1: Deliver A7~A0 = 01000101 (A6=1 for read control register and issue FIFO at address 05h).
- Step2: SDIO pin outputs RX data from RX FIFO in sequence by Data Byte 0, 1, 2 to n.
- Step3: Toggle SCS pin to high when RX FIFO is read completely.

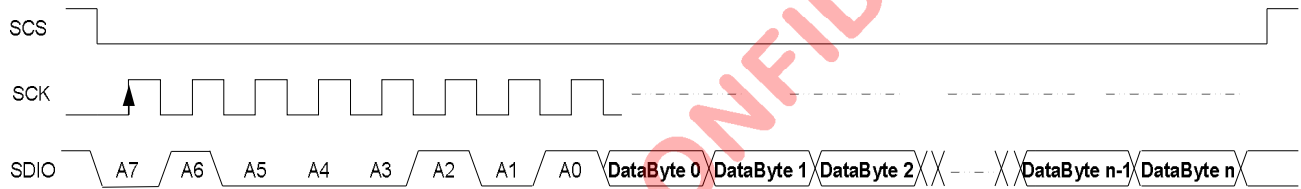

Figure 10.18 RX FIFO Read Command Timing Chart

AMICCOM CONFIDENTIAL



## 11. State machine

From accessing data point of view, if FMS=1, FIFO mode is enabled, otherwise, A7130 is in direct mode.

	SPI chip select	SPI Clock	SPI Data In	SPI Data Out	FMS register
<b>3-Wire SPI</b>	SCS	SCK	SDIO	SDIO	FIFO (FMS=1) Direct (FMS=0)
<b>4-Wire SPI</b>	SCS	SCK	SDIO	GIO1 or GIO2	FIFO (FMS=1) Direct (FMS=0)

From current consumption point of view, A7130 has below 8 operation modes.

- (1) Deep Sleep mode
- (2) Sleep mode
- (3) Idle mode
- (4) Standby mode
- (5) PLL mode
- (6) TX mode
- (7) RX mode
- (8) Star-networking mode

### 11.1 Key states

After power on reset or software reset or deep sleep mode, user has to do calibration process because all control registers are in initial values. The calibration process of A7130 is very easy, user only needs to issue Strobe commands and enable calibration registers. And then, the calibrations are automatically completed by A7130's internal state machine. Table 11.1 shows a summary of key circuitry among those strobe commands.

#### Strobe Command when AFIDS =0 (3Eh) and MIDS =0 (3Eh)

Strobe Command								Description
A7	A6	A5	A4	A3	A2	A1	A0	
1	0	0	0	1	0	0	0	Deep Sleep mode (I/Os are in tri-state)
1	0	0	0	1	0	1	1	Deep Sleep mode (I/Os are pulled high)
1	0	0	0	x	x	x	x	Sleep mode
1	0	0	1	x	x	x	x	Idle mode
1	0	1	0	x	x	x	x	Standby mode
1	0	1	1	x	x	x	x	PLL mode
1	1	0	0	x	x	x	x	RX mode
1	1	0	1	x	x	x	x	TX mode
1	1	1	0	x	x	x	x	FIFO write pointer reset
1	1	1	1	x	x	x	x	FIFO read pointer reset

Mode	Register retention	Regulator	Xtal Osc.	VCO	PLL	RX	TX	Strobe Command
Deep Sleep (Tri-state)	No	OFF	OFF	OFF	OFF	OFF	OFF	(1000-1000)b
Deep Sleep (pull-high)	No	OFF	OFF	OFF	OFF	OFF	OFF	(1000-1011)b
Sleep	Yes	ON	OFF	OFF	OFF	OFF	OFF	(1000-xxxx)b
Idle	Yes	ON	OFF	OFF	OFF	OFF	OFF	(1001-xxxx)b
Standby	Yes	ON	ON	OFF	OFF	OFF	OFF	(1010-xxxx)b
PLL	Yes	ON	ON	ON	ON	OFF	OFF	(1011-xxxx)b
TX	Yes	ON	ON	ON	ON	OFF	ON	(1101-xxxx)b
RX	Yes	ON	ON	ON	ON	ON	OFF	(1100-xxxx)b

Remark: x means "don't care"

Table 11.1. Operation mode and strobe command

**11.2 FIFO mode**

This mode is suitable for the requirements of general purpose applications and can be chosen by setting FMS = 1. After calibration, user can issue Strobe command to enter standby mode where write TX FIFO or read RX FIFO. From standby mode to packet data transmission, only one Strobe command is needed. Once transmission is done, A7130 is auto back to standby mode. Figure 11.1 and Figure 11.2 are TX and RX timing diagram respectively. Figure 11.3 illustrates state diagram of FIFO mode.

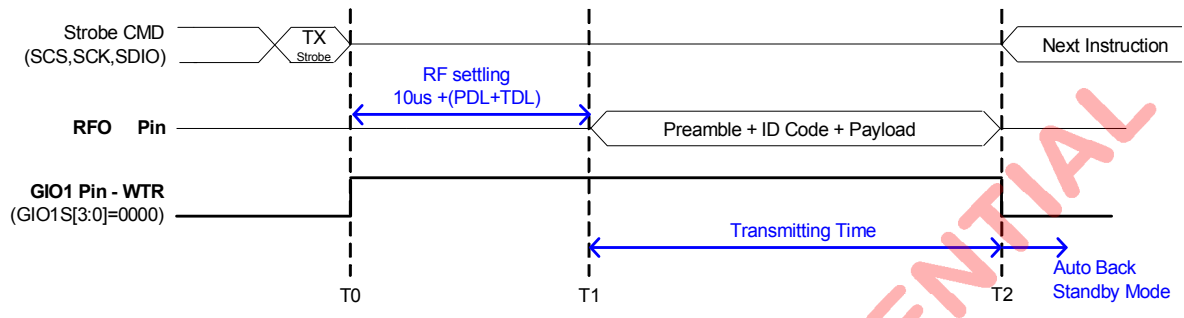

Figure 11.1 TX timing of FIFO Mode

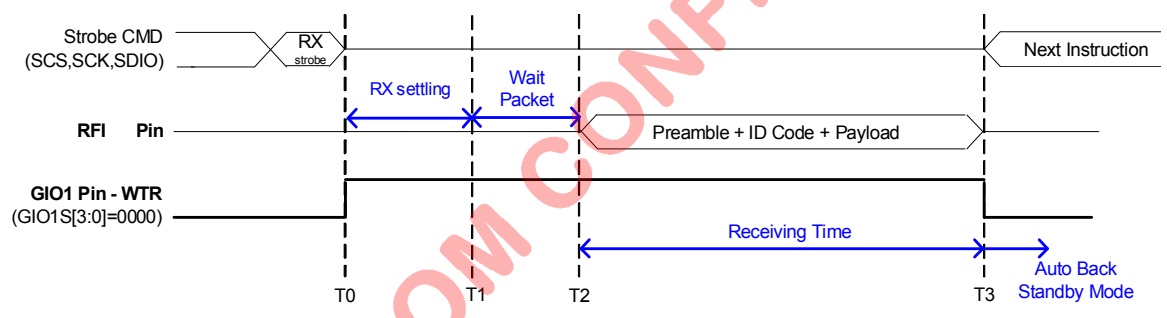

Figure 11.2 RX timing of FIFO Mode

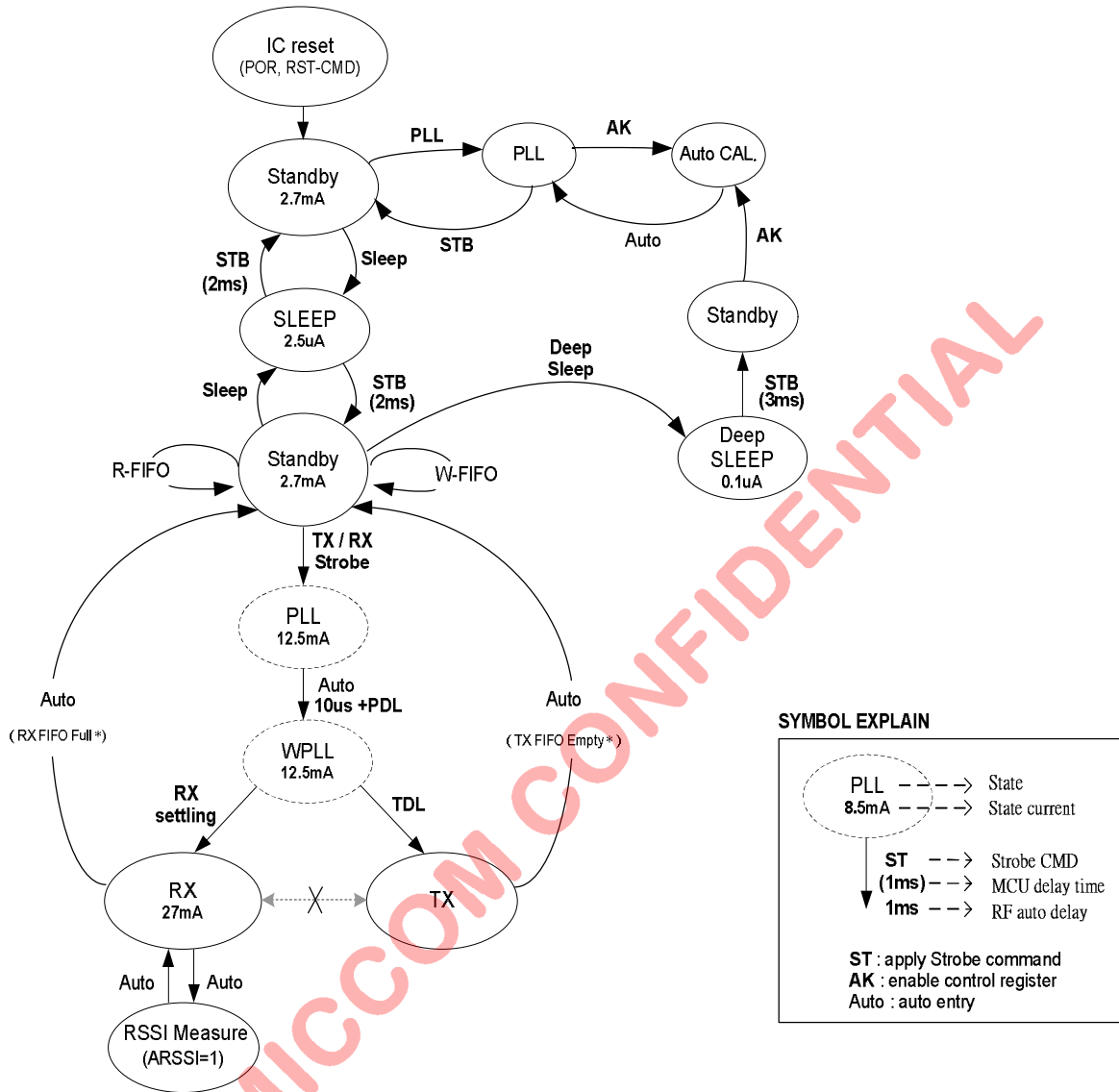

Figure 11.3 State diagram of FIFO Mode

### 11.3 Direct mode

This mode is suitable to let MCU to drive customized packet to A7130 directly by setting FMS = 0. In TX mode, MCU shall send customized packet in bit sequence (simply called raw TXD) to GIO1 or GIO2 pin. In RX mode, the receiving raw bit streams (simply called RXD) can be configured output to GIO1 or GIO2 pin. Be aware that a customized packet shall be preceded by a 32 bits preamble to let A7130 get a suitable DC estimation voltage. After calibration flow, for every state transition, user has to issue Strobe command to A7130 for fully manual control. This mode is also suitable for the requirement of versatile packet format.

Figure 11.4 and Figure 11.5 are TX and RX timing diagram in direct mode respectively. Figure 14.6 illustrates state diagram of direct mode.

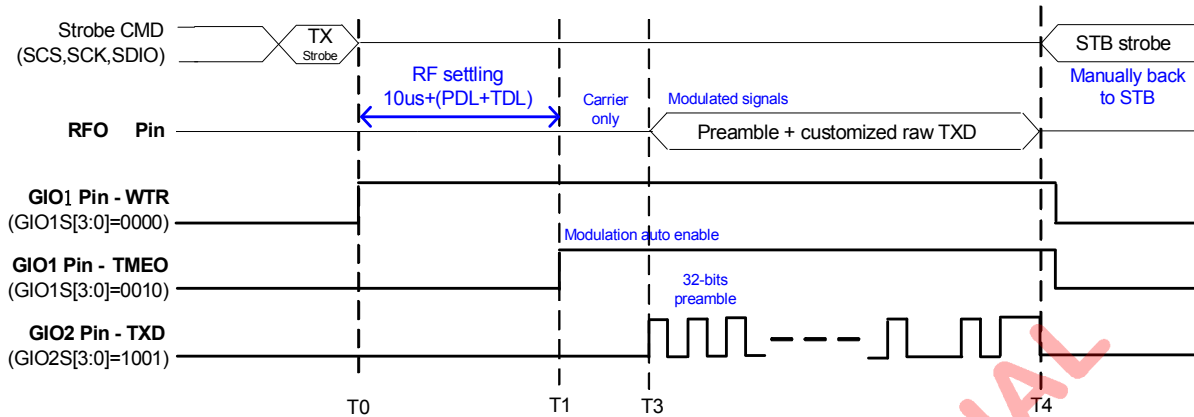

Figure 11.4 TX timing of Direct Mode

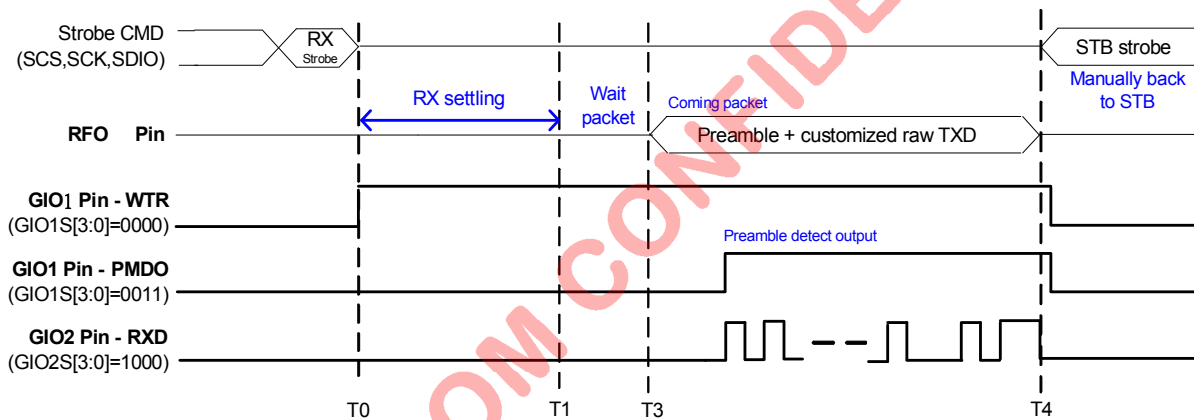
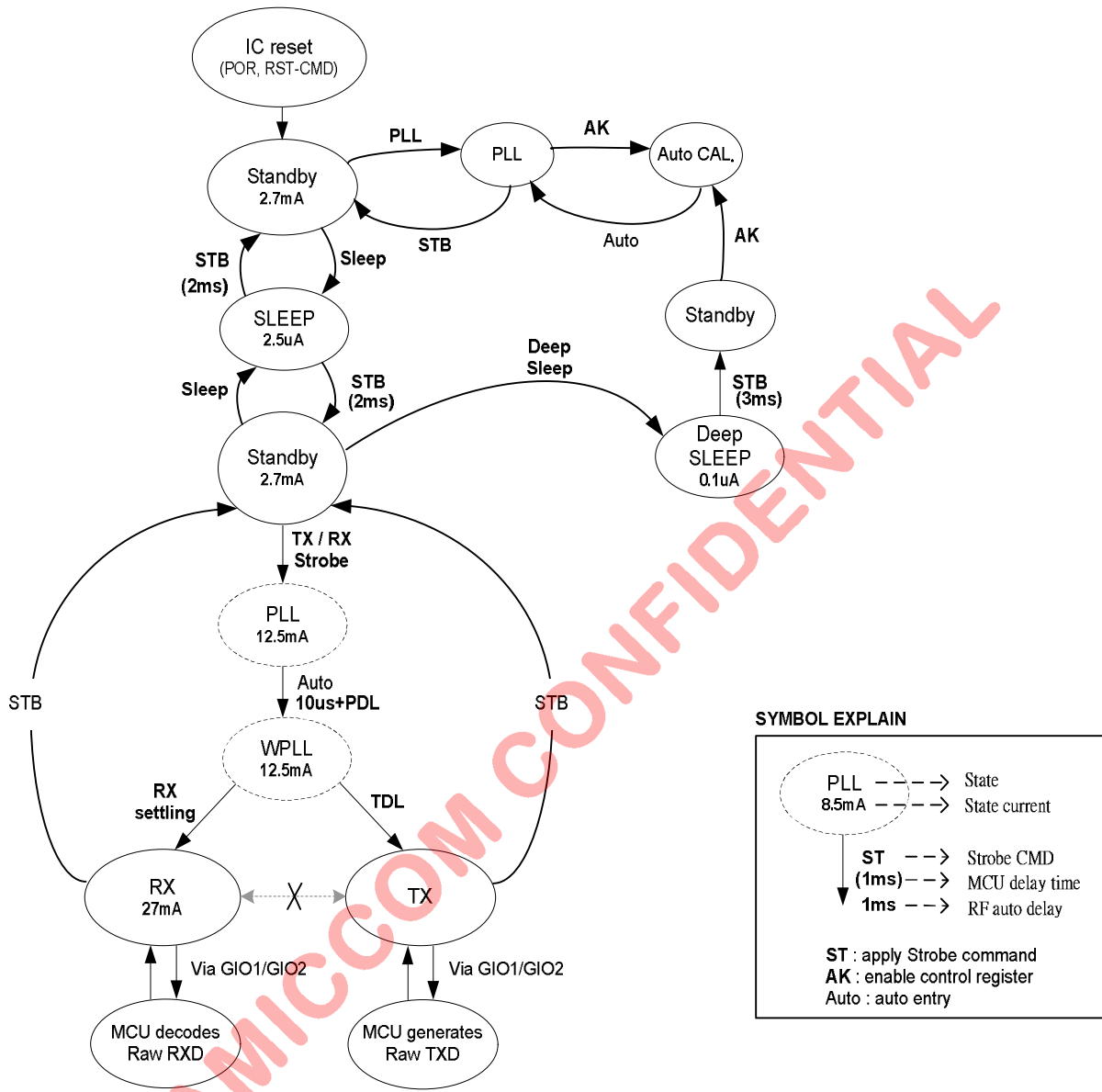

Figure 11.5 RX timing of Direct Mode

AMICCOM CONFIDENTIAL



**SYMBOL EXPLAIN**

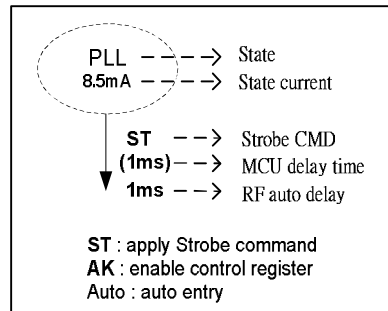

Figure 11.6 State diagram of Direct Mode

## 12. Crystal Oscillator

A7130 needs external crystal or external clock that is either 16 MHz (or 18MHz) to generate internal wanted clock.

### Relative Control Register

Clock Register (Address: 0Dh)

Name	R/W	Bit 7	Bit 6	Bit 5	Bit 4	Bit 3	Bit 2	Bit 1	Bit 0
Clock	W	CGC1	CGC0	GRC3	GRC2	GRC1	GRC0	CGS	XS
	R	IFS1	IFS0	GRC3	GRC2	GRC1	GRC0	--	--

### 12.1 Use External Crystal

Figure 12.1 shows the connection of crystal network between XI and XO pins. C1 and C2 capacitance built inside A7130 are used to adjust different crystal loading. User can set INTXC [4:0] to meet crystal loading requirement. A7130 supports low cost crystal within  $\pm 50$  ppm accuracy. Be aware that crystal accuracy requirement includes initial tolerance, temperature drift, aging and crystal loading.

Crystal Accuracy	Crystal ESR
$\pm 50$ ppm	$\leq 80$ ohm

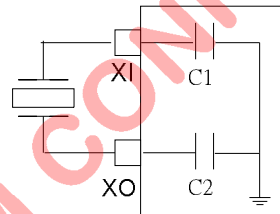

Fig12.1 Crystal oscillator circuit, set INTXC[4:0] for the internal C1 and C2 values.

### 12.2 Use External Clock

A7130 has built-in AC couple capacitor to support external clock input. Figure 12.2 shows how to connect. In such case, XI pin is left opened. XS shall be low to select external clock. The frequency accuracy of external clock shall be controlled within  $\pm 50$  ppm, and the amplitude of external clock shall be within 1.2 ~ 1.8 V peak-to-peak.

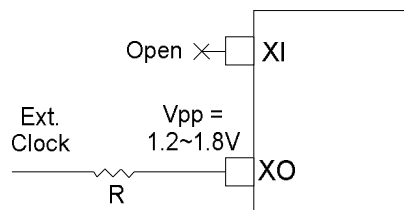

Fig12.2 External clock source. R is used to tune  $V_{pp} = 1.2\sim 1.8V$

## 13. System Clock

A7130 supports different crystal frequency by programmable “Clock Register”. Based on this, three important internal clocks  $F_{CGR}$ ,  $F_{DR}$  and  $F_{SYCK}$  are generated.

- (1)  $F_{XTAL}$ : Crystal frequency.
- (2)  $F_{XREF}$ : Crystal Ref. Clock =  $F_{XREF} * (DBL+1)$ .
- (3)  $F_{CGR}$ : Clock Generation Reference = 2MHz =  $F_{XREF} / (GRC+1)$ .
- (4)  $F_{SYCK}$ : System Clock is related to  $F_{IF}$  and  $F_{DR}$ .
- (6)  $F_{DR}$ : Data Rate Clock =  $F_{IF} / (SDR+1)$ .

Data Rate	DBL (0Fh)	$F_{CGR}$	CLK Gen.	$F_{SYCK}$	$F_{IF}$	$F_{DR}$
4Mbps	0 (FIFO mode)	2MHz	$F_{CGR} * X 32$	64MHz	4MHz	4MHz
4Mbps	1 (Direct mode)	2MHz	$F_{CGR} * X 64$	128MHz	4MHz	4MHz

Table 13.1 System clock and related clock sources

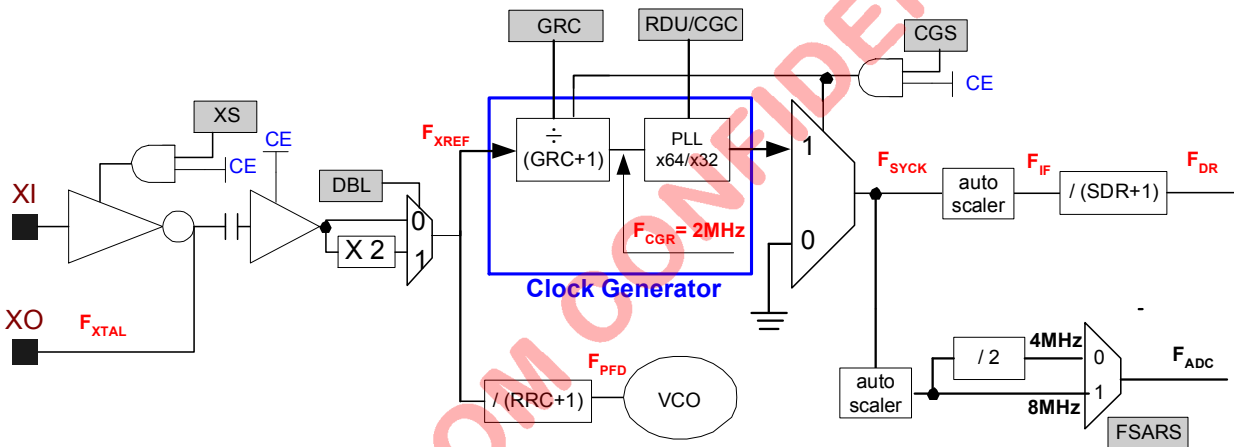

Fig13.1 System clock block diagram

## 13.2 Data Rate Setting

User has to choose 16MHz Xtal (or 18MHz) for 4Mbps applications. For more data rate options, please contact AMICCOM FAE team.

### Data rate 4Mbps

Xtal	DBL (0Fh)	GRC (0Dh)	RDU (1Ch)	CGS (0Dh)	RRC (0Fh)	CGC (0Dh)	CGS (0Dh)	IFS (1Ch)	SDR [7:0] (39h)	Note
16MHz	0	0111	0	1	00	10	1	11	0x00	FIFO mode
16MHz	1	1111	0	1	00	10	1	11	0x00	Direct mode

## 14. Transceiver LO Frequency

A7130 is a half-duplex transceiver with embedded PA and LNA. For TX or RX frequency setting, user just needs to set up LO (Local Oscillator) frequency for two ways radio transmission.

To target full range of 2.4GHz ISM band (2408 MHz to 2468 MHz), A7130 applies offset concept by LO frequency  $F_{LO} = F_{LO\_BASE} + F_{OFFSET}$ . Therefore, this device is easy to implement frequency hopping and multi-channels by just ONE register setting, PLL Register I (CHN [7:0]).

Below is the LO frequency block diagram.

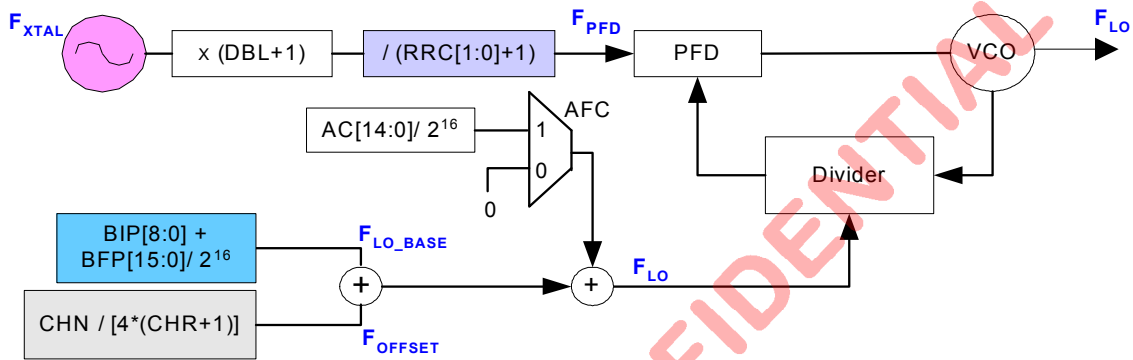
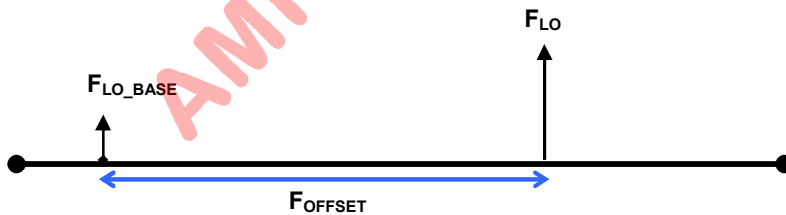

Fig14.1 Frequency synthesizer block diagram

### 14.1 LO Frequency Setting

From Figure 14.1,  $F_{LO}$  is not only for TX radio frequency but also to be RX LO frequency. To set up  $F_{LO}$ , it is easy by below 4 steps.

1. Set  $F_{LO\_BASE} \sim 2400.001\text{MHz}$ .
2. Set  $F_{CHSP} = 500\text{ KHz}$ .
3. Set  $F_{OFFSET} = \text{CHN} [7:0] \times F_{CHSP}$
4. The LO frequency,  $F_{LO} = F_{LO\_BASE} + F_{OFFSET}$



$F_{LO\_BASE}$

$$F_{LO\_BASE} = F_{PFD} \cdot \left( BIP[8:0] + \frac{BFP[15:0]}{2^{16}} \right) = (DBL + 1) \cdot \frac{F_{XTAL}}{RRC[1:0] + 1} \cdot \left( BIP[8:0] + \frac{BFP[15:0]}{2^{16}} \right)$$

Base on the above formula, i.e. 16 MHz, please refer to Table 14.1 and 14.2 as a calculation example to get LO frequency.

**DBL = 0 for FIFO mode**

STEP	ITEMS	VALUE	NOTE
1	$F_{XTAL}$	16 MHz	Crystal Frequency
2	DBL	0	Disable double function



3	RRC	0	If so, $F_{PPD} = 16\text{MHz}$
4	BIP[8:0]	0x096	To get $F_{LO\_BASE} = 2400\text{ MHz}$
5	BFP[15:0]	0x0004	To get $F_{LO\_BASE} \sim 2400.001\text{ MHz}$
6	$F_{LO\_BASE}$	2400.001 MHz	LO Base frequency

DBL = 1 for Direct mode

STEP	ITEMS	VALUE	NOTE
1	$F_{XTAL}$	16 MHz	Crystal Frequency
2	DBL	1	Enable double function
3	RRC	0	If so, $F_{PPD} = 16\text{MHz}$
4	BIP[8:0]	0x04B	To get $F_{LO\_BASE} = 2400\text{ MHz}$
5	BFP[15:0]	0x0002	To get $F_{LO\_BASE} \sim 2400.001\text{ MHz}$
6	$F_{LO\_BASE}$	2400.001 MHz	LO Base frequency

Table 14.1 How to set  $F_{LO\_BASE}$

How to set  $F_{TXRF} = F_{LO} = F_{LO\_BASE} + F_{OFFSET} \sim 2405.001\text{ MHz}$

STEP	ITEMS	VALUE	NOTE
1	$F_{LO\_BASE}$	2400.001 MHz	After set up BIP and BFP
2	CHR[3:0]	[0111]	To get $F_{CHSP} = 500\text{ KHz}$ if DBL = 0 for FIFO mode.
		[1111]	To get $F_{CHSP} = 500\text{ KHz}$ if DBL = 1 for Direct mode.
4	CHN[7:0]	0x0A	$F_{OFFSET} = 500\text{ KHz} * (\text{CHN}) = 5\text{MHz}$
6	$F_{LO}$	2405.001 MHz	Get $F_{LO} = F_{LO\_BASE} + F_{OFFSET}$
7	$F_{TXRF}$	2405.001 MHz	$F_{TXRF} = F_{LO}$

Table 14.2 How to set  $F_{TXRF}$

For 16MHz crystal, below is the calculation detail for  $F_{PPD}$  and  $F_{CHSP}$ .

$$F_{CHSP} = \frac{F_{PPD}}{4 \cdot (\text{CHR}[3:0] + 1)}$$

$F_{XTAL}$ (MHz)	DBL (0Fh)	RRC (0Fh)	$F_{PPD}$ (MHz)	CHR [3:0]	$F_{CHSP}$ (KHz)	Note
16	0	00	16	0111	500	Recommend
16	1	00	32	1111	500	Recommend

## 14.2 IF Side Band Select

Since A7130 is a low-IF TRX, in RX mode, the  $F_{RXLO}$  shall be set to shift a  $F_{IF}$  (i.e.  $F_{IF} = 4\text{MHz} @ 4\text{Mbps}$ ) regarding to coming  $F_{TXRF}$ . Therefore, A7130 offers two methods to set up  $F_{LO}$  while A7130 is exchanging from TX mode to RX mode.

AIF register is used to enable Auto IF function for Auto IF exchange mode. And ULS registers is used for fast exchange mode because of reduction of PLL settling time.

(1) Auto IF exchange mode

AIF (01h)	ULS (19h)	$F_{RXLO}$ Formula	Note
1	0	$F_{RXLO} = F_{LO} - F_{IF}$	Auto-minus a $F_{IF}$ because ULS = 0
1	1	$F_{RXLO} = F_{LO} + F_{IF}$	Auto-plus a $F_{IF}$ because ULS = 1

(2) Fast exchange mode

AIF (01h)	ULS (19h)	$F_{RXLO}$ Formula	Note
0	0	$F_{RXLO} = F_{LO}$	The coming $F_{TXRF}$ shall be $(F_{RXLO} + F_{IF})$
0	1	$F_{RXLO} = F_{LO}$	The coming $F_{TXRF}$ shall be $(F_{RXLO} - F_{IF})$

## 14.2.1 Auto IF Exchange

A7130 supports Auto IF offset function by setting AIF = 1. In such case,  $F_{TXRF}$  between master and slave is the same so that there is only one carrier frequency ( $F_{Carrier}$ ) during communications. Meanwhile,  $F_{RXLO}$  during TRX exchanging is auto shifted  $F_{IF}$ . See below Figures and Table 14.3 for details.

### Master

AIF=1 and ULS=0,  $F_{RXLO}$  is auto shifted lower than  $F_{TXRF}$  for a ( $F_{IF}$ ).

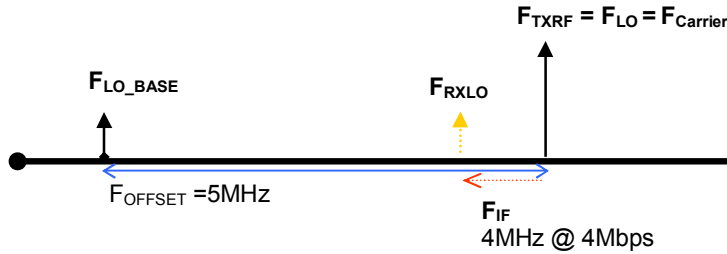

Master	AIF	ULS	CHN[7:0]	$F_{CHSP}$ (KHz)	$F_{LO\_BASE}$ (MHz)	$F_{TXRF}$ (MHz)	$F_{RXLO}$ (MHz)
TX	1	0	0x0A	500	2400.001	2405.001	--
RX	1	0	0x0A	500	2400.001	--	2401.001

### Slave

AIF=1 and ULS=0,  $F_{RXLO}$  is auto shifted lower than  $F_{TXRF}$  for a ( $F_{IF}$ ).

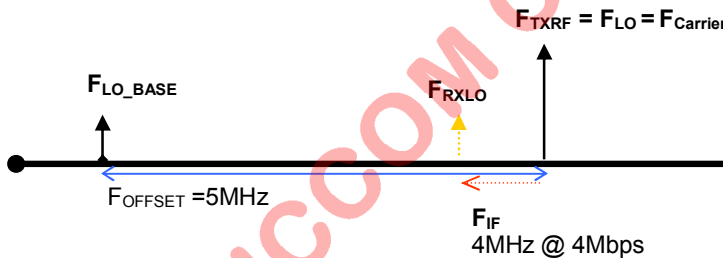

Slave	AIF	ULS	CHN[7:0]	$F_{CHSP}$ (KHz)	$F_{LO\_BASE}$ (MHz)	$F_{TXRF}$ (MHz)	$F_{RXLO}$ (MHz)
TX	1	0	0x0A	500	2400.001	2405.001	--
RX	1	0	0x0A	500	2400.001	--	2401.001

Table 14.3 Auto IF exchange mode while TRX exchanging

### 14.2.2 Fast Exchange

Fast exchange can reduce the PLL settling time during TRX exchanging because  $F_{RXLO}$  and  $F_{TXRF}$  are kept to the same  $F_{LO}$  in either master or slave side. However, there are two on-air frequency ( $F_{Carrier (master)}$ ,  $F_{Carrier (slave)}$ ) during communications. In such case, user has to control  $ULS = 0$  in master side and  $ULS = 1$  in slave side for two ways radio. See below Figures and Table 14.4 for details.

**Master**

AIF=0 and ULS=0, Master is set to up side band.

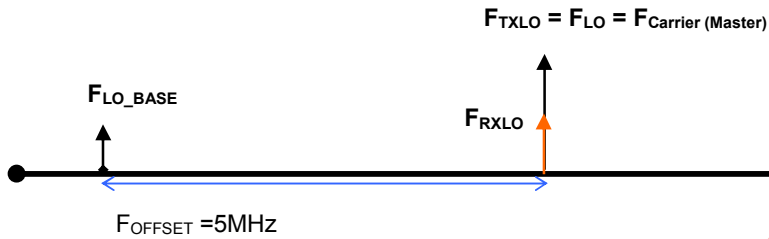

**Slave**

AIF=0 and ULS=1, Slave is set to low side band.

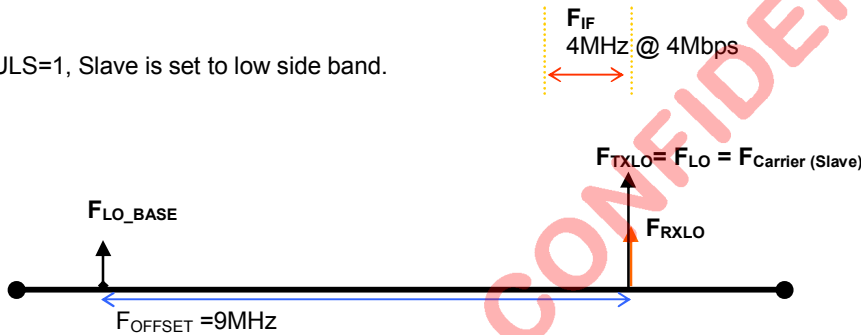

Master	AIF	ULS	CHN[7:0]	F <sub>CHSP</sub> (KHz)	F <sub>LO_BASE</sub> (MHz)	F <sub>TXRF</sub> (MHz)	F <sub>RXLO</sub> (MHz)
TX	0	0	0x0A	500	2400.001	2405.001	--
RX	0	0	0x0A	500	2400.001	--	2405.001

Slave	AIF	ULS	CHN[7:0]	F <sub>CHSP</sub> (KHz)	F <sub>LO_BASE</sub> (MHz)	F <sub>TXRF</sub> (MHz)	F <sub>RXLO</sub> (MHz)
TX	0	1	0x12	500	2400.001	2409.001	--
RX	0	1	0x12	500	2400.001	--	2409.001

Table 14.4 Fast exchange mode while TRX exchanging

## 14.3 Auto Frequency Compensation

The AFC function (Auto Frequency Compensation) supports to use low accuracy crystal ( $\pm 50$  ppm) on A7130 without sensitivity degradation. The AFC concept is automatically fine tune RX LO frequency ( $F_{RXLO}$ ). User can read AC [14:0] to know the compensation value of  $F_{RXLO}$ .

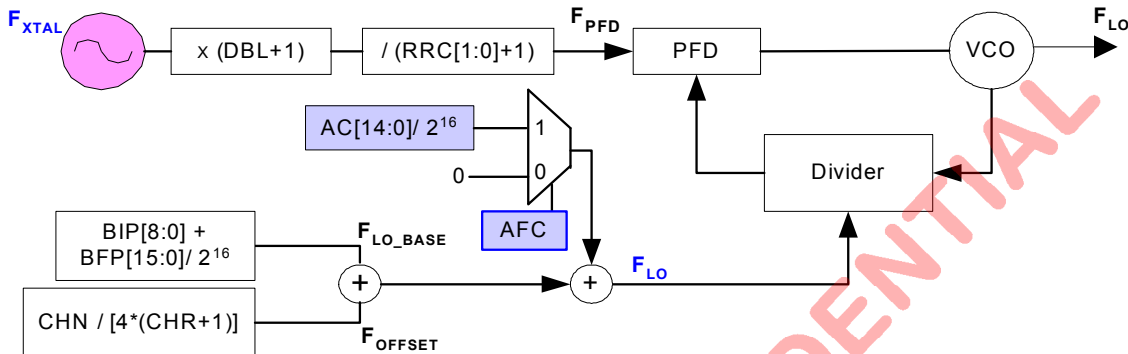

Figure 14.3 Block Diagram of enabling AFC function

For AFC procedure, please refer to A7130's reference code and contact AMICCOM FAE team for details.

## 15. Calibration

A7130 needs calibration process after deep sleep mode or power on reset or software reset. Below are six calibration items inside the device.

1. VCO Current Calibration.
2. VCO Bank Calibration.
3. VCO Deviation Calibration.
4. IF Filter Bank Calibration.
5. RSSI Calibration.
6. RC Oscillator Calibration.

### 15.1 Calibration Procedure

The purpose to execute the above calibration items is to deal with Foundry process deviation. After calibrations, A7130 will be set to the best working conditions without concerning Foundry process deviation to impact A7130's RF performance.

In general, user can use A7130's auto calibration function by just enabling calibration items and checking its calibration flag. For detailed calibration procedures, please refer to A7130 reference code of `initRF()` subroutine and `A7130_Cal()` subroutine.

1. Initialize A7130 by calling the subroutine of `initRF()`.
  - Initialize all control registers by calling the subroutine of `A7130_Config()`.
  - Execute all calibration items by calling the subroutine of `A7130_Cal()`.

## 16. FIFO (First In First Out)

A7130 has the separated physical 64-bytes TX and RX FIFO inside the device. To use A7130's FIFO mode, user just needs to enable FMS =1. For FIFO accessing, TX FIFO (write-only) and RX FIFO (read-only) share the same register address 05h. TX FIFO represents transmitted payload. On the other hand, RX circuitry synchronizes ID Code and stores received payload into RX FIFO.

### 16.1 TX Packet Format in FIFO mode

#### 16.1.1 Basic FIFO mode

If FCL[1:0] = 00 and ENRL = 0, A7130 is formed a Basic FIFO mode which can also support Auto-ack/ Auto-resend function. There is no MAC header in TX packet format. ID code is a PHY header used to be the frame sync to enable RX FIFO receiving.

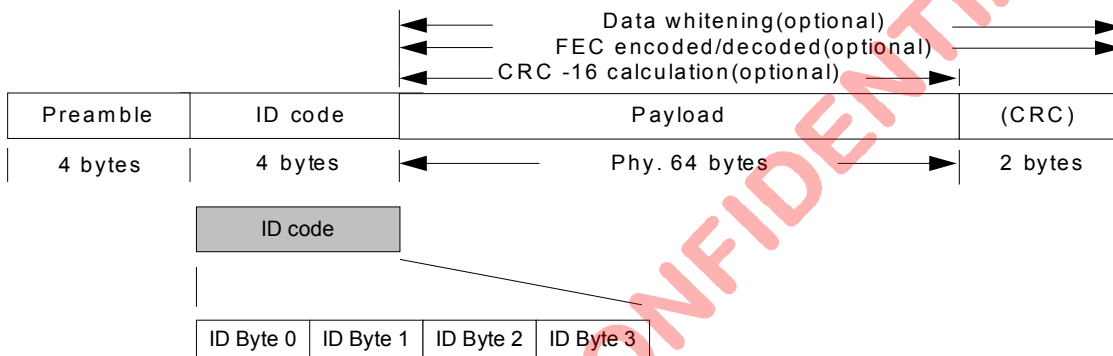

Figure 16.1 TX packet format of basic FIFO mode

#### Preamble:

The packet is led by a self-generated preamble which is composed of alternate 0 and 1. If the first bit of ID code is 0, preamble shall be 0101...0101. In the contrast, if the first bit of ID code is 1, preamble shall be 1010...1010. Preamble length is recommended to set 4 bytes by PML [1:0] (20h).

#### ID code:

ID code is recommended to set 4 bytes by IDL[1:0] = [01] and ID Code is stored into ID Data register by sequence ID Byte 0, 1, 2 and 3. If RX circuitry check ID code is correct, payload will be written into RX FIFO. In addition, user can set ID code error tolerance (0~ 7bit error) by setting ETH [2:0] during ID synchronization check.

#### Payload:

Payload length is programmable by FEP [11:0]. The physical FIFO depth is 64 bytes. A7130 also supports logical FIFO extension up to 4K bytes.

#### CRC:

In FIFO mode, if CRC is enabled (CRCS=1), 2-bytes of CRC value is self-generated and attached at the footer of the packet. In the same way, RX circuitry will check CRC value and show the result to CRC Flag.

#### 16.1.2 Advanced FIFO mode

A7130 supports to self generated MAC header to form an advanced FIFO mode by enabling FCL[1:0], ENRL... Therefore, A7130 can support ACK FIFO (FCB1~FCB3) and dynamic FIFO length depending on configurations.

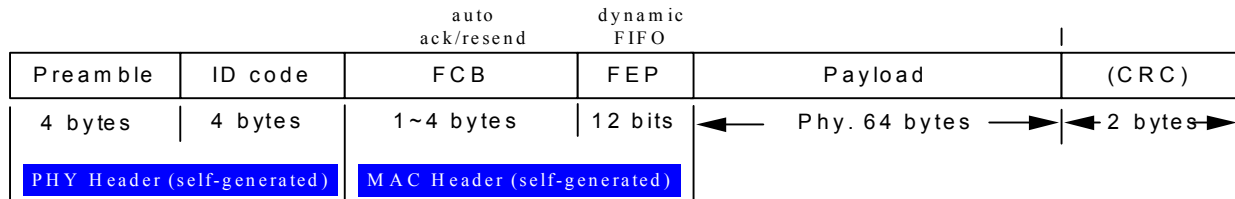

Figure 16.2 TX packet format of advanced FIFO mode.

**FCB:**

If FCL[1:0] ≠ 00, FCB header is enabled to support ACK FIFO by (FCB1~FCB3). The FCB is frame control byte. FCB0 is NOT allowed to program but carry a dedicated header (00111b) and SID [2:0] (Serial ID of packet number). FCB1~3 are used for customized information in FCB field.

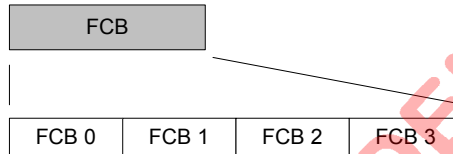

Figure 16.3 FCB (Frame Control Field)

**FEP:**

If ENRL = 1, A7130 supports dynamic FIFO. FEP [11:0] is self-generated to add into TX packet. In RX side, FEP[11:0] of the coming TX packet will be detected and stored into LENF [11:0] register.

**HEC:**

If HECS = 1, A7130 supports to self-generated a HEC byte which is a local CRC-8 of the MAC header. This HEC byte is an optional feature to calculate CRC result of MAC Header. HEC is located at the end of the MAC header.

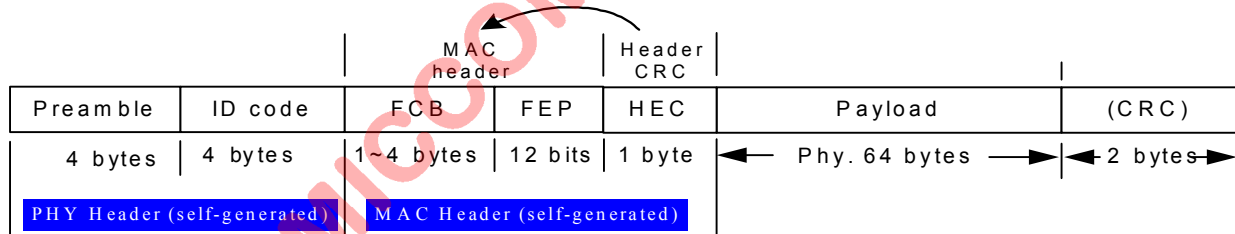

Figure 16.4 HEC (CRC for MAC Header)

## 16.2 Bit Stream Process in FIFO mode

A7130 supports 3 optional bit stream process for payload in FIFO mode, they are,

- (1) CCITT-16 CRC
- (2) (7, 4) Hamming FEC
- (3) Data Whitening by XOR PN7 (7-bits Pseudo Random Sequence). The initial seed of PN7 is set by WS [6:0]

**CRC (Cyclic Redundancy Check):**

1. CRC is enabled by CRCS= 1. TX circuitry calculates the CRC value of payload (preamble and ID code are excluded) and transmits 2-bytes CRC value after payload.
2. RX circuitry checks CRC value and shows the result to CRCF. If CRCF=0, received payload is correct, else error occurred.

### FEC (Forward Error Correction):

1. FEC is enabled by FECS= 1. Payload and CRC value (if CRCS=1) are encoded by (7, 4) Hamming code.
2. Each 4-bits (nibble) of payload is encoded into 7-bits code word and delivered out automatically.  
**(ex., 64 bytes payload will be encoded to 128 code words, each code word is 7 bits.)**
3. RX circuitry decodes received code words automatically. Each code word can correct 1-bit error. Once 1-bit error occurred, FECF=1 (00h).

### Data Whitening:

1. Data whitening is enabled by WHTS= 1. Payload and CRC value (if CRCS=1) or their encoded code words (if FECS=1) are encrypted by bit XOR operation with PN7. The initial seed of PN7 is set by WS [6:0].
2. RX circuitry decrypts received payload and 2-bytes CRC (if CRCS=1) automatically. Please noted that user shall set the same WS [6:0] (22h) to TX and RX.

## 16.3 Transmission Time

Based on CRC and FEC options, the transmission time are different. See table 16.1 for details.

Data Rate = 4 Mbps

Data Rate	Preamble (bits)	ID Code (bits)	Payload (bits)	CRC (bits)	FEC	Transmission Time / Packet
4Mbps	32	32	512	Disable	Disable	576 bit X 0.25 us = 144 us
	32	32	512	16 bits	Disable	592 bit X 0.25 us = 148 us
	32	32	512	Disable	512 x 7 / 4	960 bit X 0.25 us = 240 us
	32	32	512	16 x 7 / 4	512 x 7 / 4	988 bit X 0.25 us = 247 us

Table 16.1 Transmission time

## 16.4 Usage of TX and RX FIFO

In application points of view, A7130 supports 2 options of FIFO arrangement.

- (1) Easy FIFO
- (2) Segment FIFO
- (3) FIFO extension

For FIFO operation, A7130 supports Strobe command to reset TX and RX FIFO pointer as shown below. User can refer to section 10.5 for details.

### Strobe Command

Strobe Command								Description
A7	A6	A5	A4	A3	A2	A1	A0	
1	1	1	0	x	x	X	x	FIFO write pointer reset (for TX FIFO)
1	1	1	1	x	x	X	x	FIFO read pointer reset (for RX FIFO)

## 16.4.1 Easy FIFO

In Easy FIFO mode, max FIFO length is 64 bytes. FIFO length is equal to ( FEP [11:0] +1 ) where FEP [11:0] is max 0x003F. User just needs to control FEP [11:0] (03h) and disable PSA and FPM as shown below.

TX-FIFO (byte)	RX-FIFO (byte)	FEP[11:0] (03h)	PSA[5:0] (04h)	FPM[1:0] (04h)
1	1	0x00	0	0
8	8	0x07	0	0
16	16	0x0F	0	0
32	32	0x1F	0	0
64	64	0x3F	0	0

Table 16.2 Control registers of Easy FIFO

### Procedures of TX FIFO Transmitting

1. Initialize all control registers (refer A7130 reference code).
2. Set FEP [11:0] = 0x003F for 64-bytes FIFO.
3. Send Strobe command – TX FIFO write pointer reset.
4. MCU writes 64-bytes data to TX FIFO.
5. Send TX Strobe Command and monitor WTR signal.
6. Done.

### Procedures of RX FIFO Reading

1. When RX FIFO is full, WTR (or FSYNC) can be used to trigger MCU for RX FIFO reading.
2. Send Strobe command – RX FIFO read pointer reset.
3. MCU monitors WTR signal and then read 64-bytes from RX FIFO.
4. Done.

### Definitions

DP : Deliver Pointer  
RP : Received Pointer

TX FIFO Empty = DP reaches FEP[11:0]  
RX FIFO FULL = RP reaches FEP[11:0]

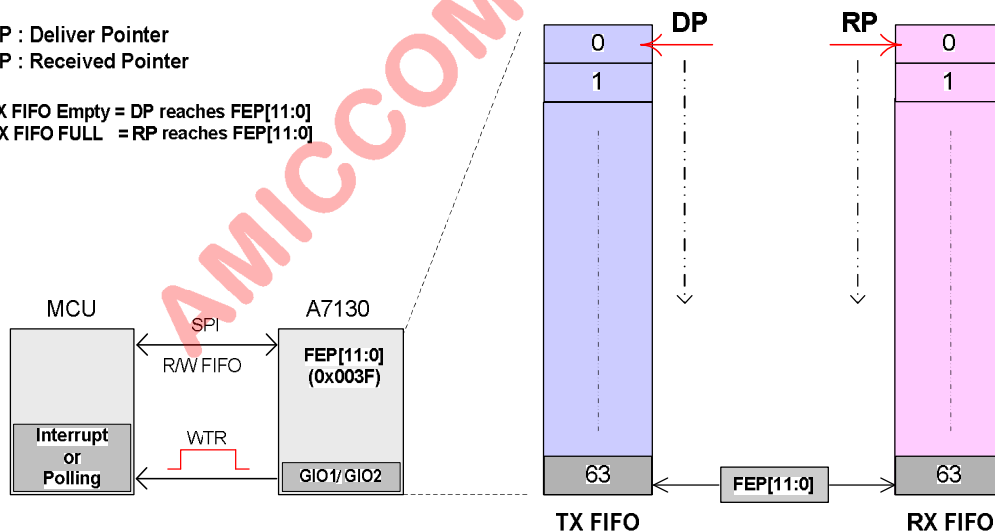

Figure 16.5 Easy FIFO



## 16.4.2 Segment FIFO

In Segment FIFO, TX FIFO length is equal to (FEP [11:0] – PSA [5:0]+ 1). FPM [1:0] should be zero. This function is very useful for button applications. In such case, each button is used to transmit fixed code (data) every time. During initialization, each fixed code is written into corresponding segment FIFO once and for all. Then, if button is triggered, MCU just assigns corresponding segment FIFO (PSA [5:0] and FEP [11:0]) and issues TX strobe command. Table 16.4 explains the details if TX FIFO is arranged into 8 segments, each TX segment and RX FIFO length are 8 bytes.

Segment	PSA	FEP	TX FIFO Length	PSA[5:0]	FEP[11:0]	FPM[1:0]
1	PSA1	FEP1	8 bytes	0x00	0x07	0
2	PSA2	FEP2	8 bytes	0x08	0x0F	0
3	PSA3	FEP3	8 bytes	0x10	0x17	0
4	PSA4	FEP4	8 bytes	0x18	0x1F	0
5	PSA5	FEP5	8 bytes	0x20	0x27	0
6	PSA6	FEP6	8 bytes	0x28	0x2F	0
7	PSA7	FEP7	8 bytes	0x30	0x37	0
8	PSA8	FEP8	8 bytes	0x38	0x3F	0

RX FIFO Length	PSA[5:0]	FEP[11:0]	FPM[1:0]
8 bytes	0	0x0007	0

Table 16.3 Segment FIFO is arranged into 8 segments

### Procedures of TX FIFO Transmitting

1. Initialize all control registers (refer A7130 reference code).
2. Issue Strobe command – TX FIFO write pointer reset.
3. MCU writes fixed code into corresponding segment FIFO once and for all.
4. To consign Segment 1, set PSA = 0x00 and FEP= 0x0007  
 To consign Segment 2, set PSA = 0x08 and FEP= 0x000F  
 To consign Segment 3, set PSA = 0x10 and FEP= 0x0017  
 To consign Segment 4, set PSA = 0x18 and FEP= 0x001F  
 To consign Segment 5, set PSA = 0x20 and FEP= 0x0027  
 To consign Segment 6, set PSA = 0x28 and FEP= 0x002F  
 To consign Segment 7, set PSA = 0x30 and FEP= 0x0037  
 To consign Segment 8, set PSA = 0x38 and FEP= 0x003F
5. Issue TX Strobe Command and monitor WTR signal.
6. Done.

### Procedures of RX FIFO Reading

1. When RX FIFO is full, WTR (or FSYNC) is used to trigger MCU for RX FIFO reading.
2. Issue Strobe command – RX FIFO read pointer reset.
3. MCU monitors WTR signal and then read 8-bytes from RX FIFO.
4. Done.

Definitions

DP : Deliver Pointer  
 RP : Received Pointer

TX FIFO Empty = DP reaches FEP[11:0]  
 RX FIFO FULL = RP reaches FEP[11:0]

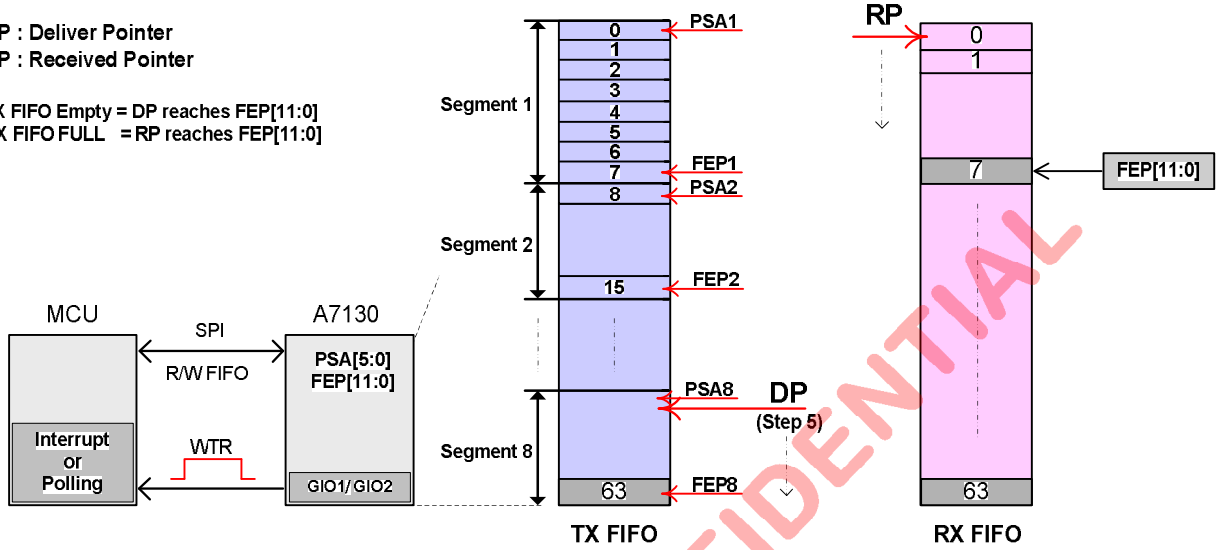

Figure 16.6 Segment FIFO Mode

AMICCOM CONFIDENTIAL

## 16.4.3 FIFO Extension

A7130 supports FIFO extension up to 4K bytes from the 64 bytes physical TX FIFO and RX FIFO. The FIFO extension length is configured by (**FEP [11:0] +1 and PSA [5:0] =0**). FPM [1:0] is used to set the **FPF threshold** which FPF is FIFO Pointer Flag to inform MCU the timing of reading RX FIFO and refilling TX FIFO.

Please be notice, SPI speed is important to prevent error operation (over-write) in FIFO extension mode. We recommend the min. SPI speed shall be equal or greater than (**A7% 0 on-air data rate + 500Kbps**). Please refer to A7130's reference code (FIFO extension) for details.

For example, if A7130 data rate = 4Mbps and FIFO extension = 256 bytes.

TX			RX			Control Registers		
FIFO Length (byte)	FPF Threshold	Max. SPI Data Rate	FIFO Length (byte)	FPF Threshold	Max. SPI Data Rate	FEP[7:0]	FPM[1:0]	PSA[5:0]
256	Delta = 04	10 Mbps	256	Delta = 60	10 Mbps	0xFF	00	0
	Delta = 08	10 Mbps		Delta = 56	10 Mbps		01	0
	Delta = 12	10 Mbps		Delta = 52	10 Mbps		10	0
	<b>Delta = 16</b>	<b>8 Mbps</b>		<b>Delta = 48</b>	<b>8 Mbps</b>		<b>11</b>	<b>0</b>

Table 16.4 How to set FIFO extension when A7130 is at 4Mbps data rate

### Procedures of TX FIFO Extension

1. Initialize all control registers (refer A7130 reference code).
2. Set FEP [11:0] = 0x0FF for 256-bytes FIFO extension.
3. Set FPM [1:0] = 11 for FPF threshold.
4. Set CKO Register = 0x12
5. Issue Strobe command – TX FIFO write pointer reset.
6. MCU writes 1<sup>st</sup> 64-bytes TX FIFO.
7. Issue TX Strobe command.
8. MCU monitors FPF from A7130's CKO pin.
9. FPF triggers MCU to write 2<sup>nd</sup> 48-bytes TX FIFO.
10. Monitor FPF.
11. FPF triggers MCU to write 3<sup>rd</sup> 48-bytes TX FIFO.
12. Monitor FPF.
13. FPF triggers MCU to write 4<sup>th</sup> 48-bytes TX FIFO.
14. Monitor FPF.
15. FPF triggers MCU to write 5<sup>th</sup> 48-bytes TX FIFO.
16. Done.

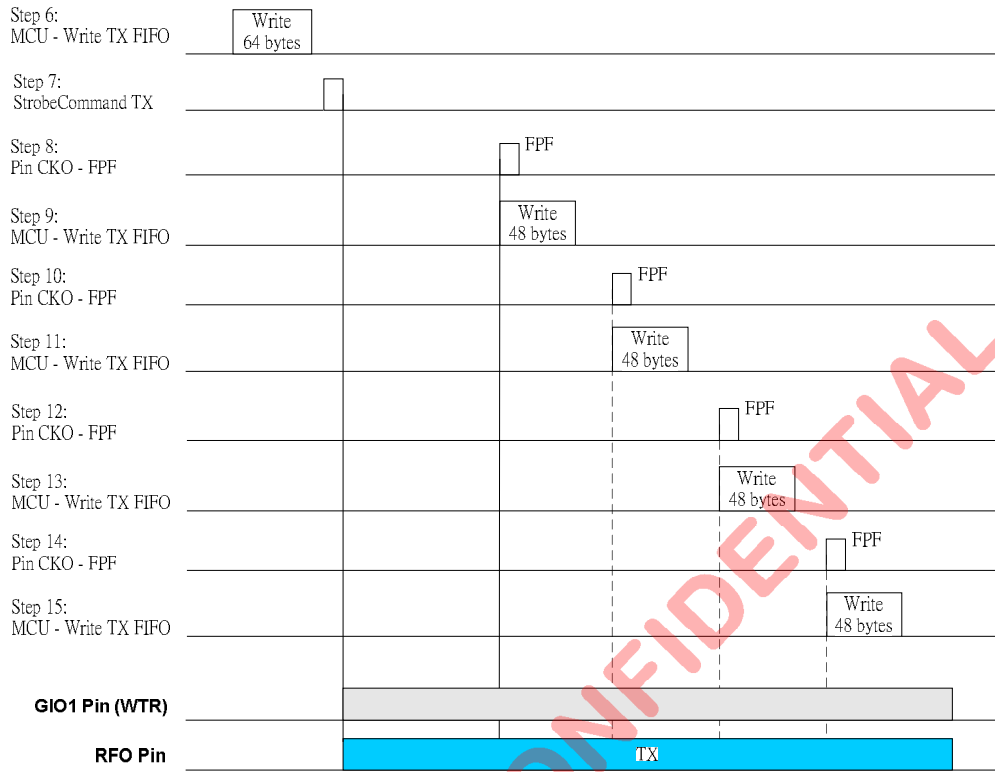

### Definitions

**DP** : Deliver Pointer  
**RP** : Received Pointer  
**WTX** : Write TX FIFO Pointer  
**Delta** :  $WTX - DP + 1 = 16$  if  $FPM=11$

**TX FIFO Empty** = DP reaches FEP[11:0]  
**RX FIFO FULL** = RP reaches FEP[11:0]

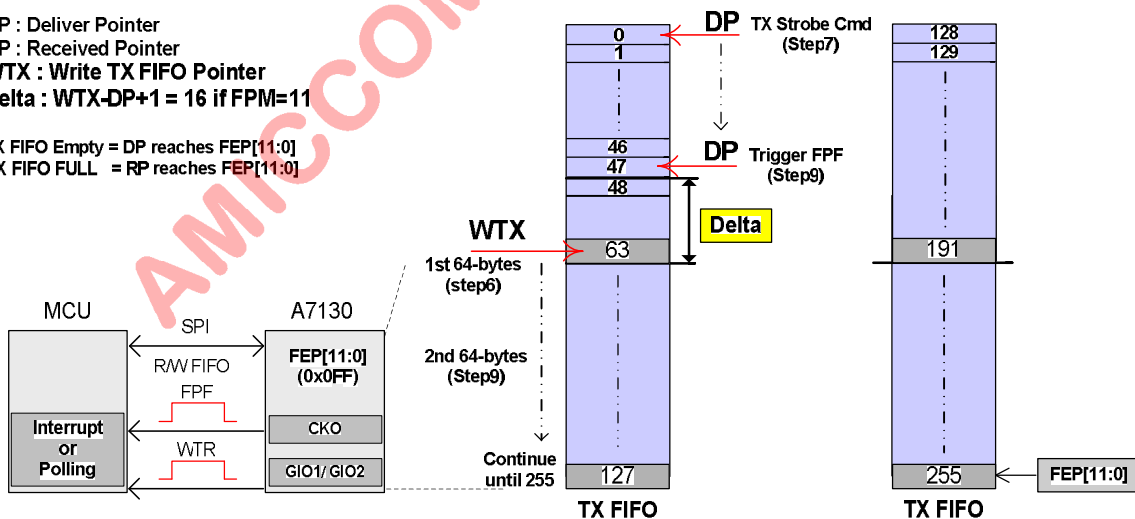
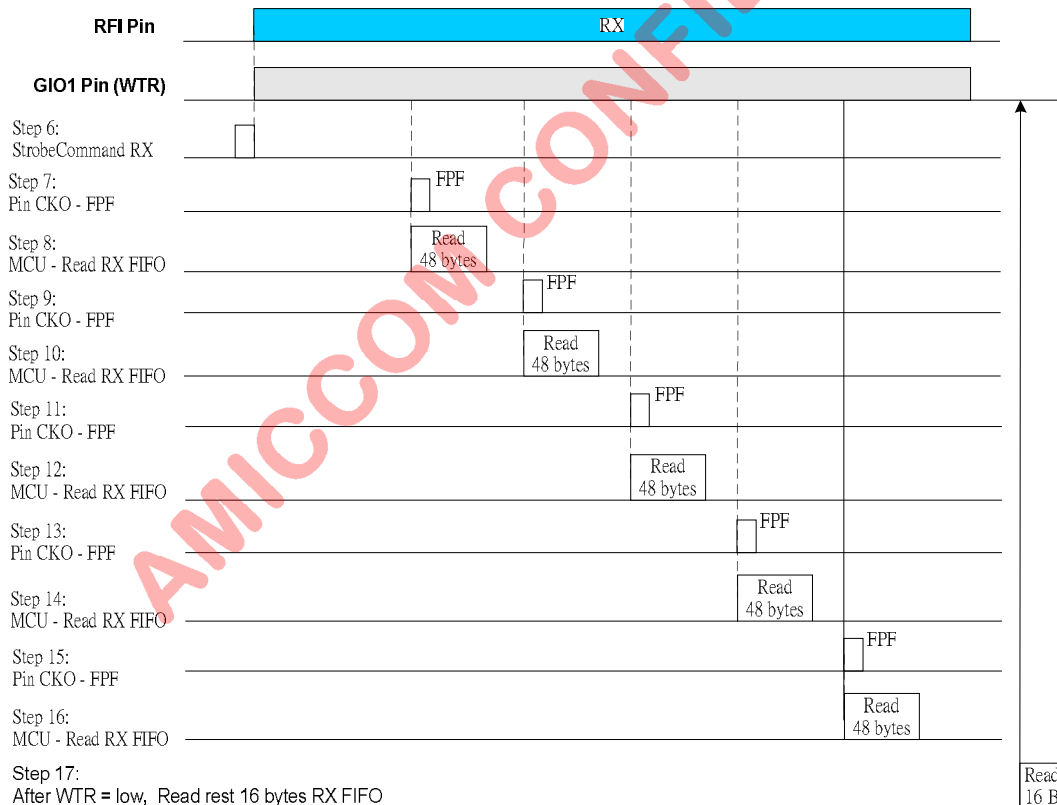

Figure 16.7 TX FIFO Extension

## Procedures of RX FIFO Reading

1. Initialize all control registers (refer A7130 reference code).
2. Set FEP [11:0] = 0x0FF for 256-bytes FIFO extension.
3. Set FPM [1:0] = [11b] for FPF threshold.
4. Set CKO Register = 0x12
5. Issue Strobe command – RX FIFO read pointer reset.
6. Issue RX Strobe command.
7. MCU monitors FPF from A7130's CKO pin.
8. FPF triggers MCU to read 1<sup>st</sup> 48-bytes RX FIFO.
9. Monitor FPF.
10. FPF triggers MCU to read 2<sup>nd</sup> 48-bytes RX FIFO.
11. Monitor FPF.
12. FPF triggers MCU to read 3<sup>rd</sup> 48-bytes RX FIFO.
13. Monitor FPF.
14. FPF triggers MCU to read 4<sup>th</sup> 48-bytes RX FIFO.
15. Monitor FPF.
16. FPF triggers MCU to read 5<sup>th</sup> 48-bytes RX FIFO.
17. Monitor WTR falling edge or WTR = low, read the rest 16-bytes RX FIFO
18. Done.



Definitions

DP : Deliver Pointer  
 RP : Received Pointer  
 RRX : Read FIFO Pointer  
 Delta :  $RP - RRX + 1 = 48$  if  $FPM=11$   
 TX FIFO Empty = DP reaches FEP[11:0]  
 RX FIFO FULL = RP reaches FEP[11:0]

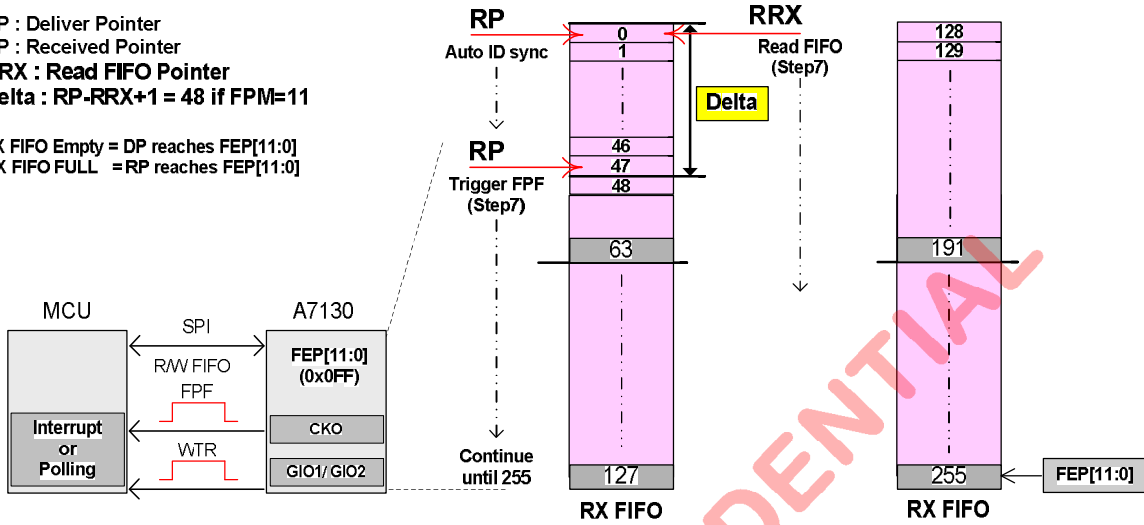

Figure 16.8 RX FIFO Extension Mode

AMICCOM CONFIDENTIAL

## 17. ADC (Analog to Digital Converter)

A7130 has built-in 8-bits ADC for RSSI measurement and internal thermal sensor by enabling ADCM. User can just use the recommended values of ADC from Table 17.1. Please noted that ADC clock can be selected by setting FSARS (4MHz or 8MHz). The ADC converting time is 20 x ADC clock periods.

XADS (1Fh)	RSS (1Ch)	ARSSI (01h)	ADCM (01h)	ERSSM (1Ch)	FSARS (1Fh)	CDM (1Fh)	Standby Mode	RX Mode
0	1	1	1	1	0	1	Thermal sensor	RSSI

Table 17.1 Setting of RSSI measurement

### 17.1 RSSI Measurement

A7130 supports 8-bits digital RSSI to detect RF signal strength. RSSI value is stored in ADC [7:0] (1Eh). Fig 17.1 shows a typical plot of RSSI reading as a function of input power. Be aware RSSI accuracy is about  $\pm 6\text{dBm}$ .

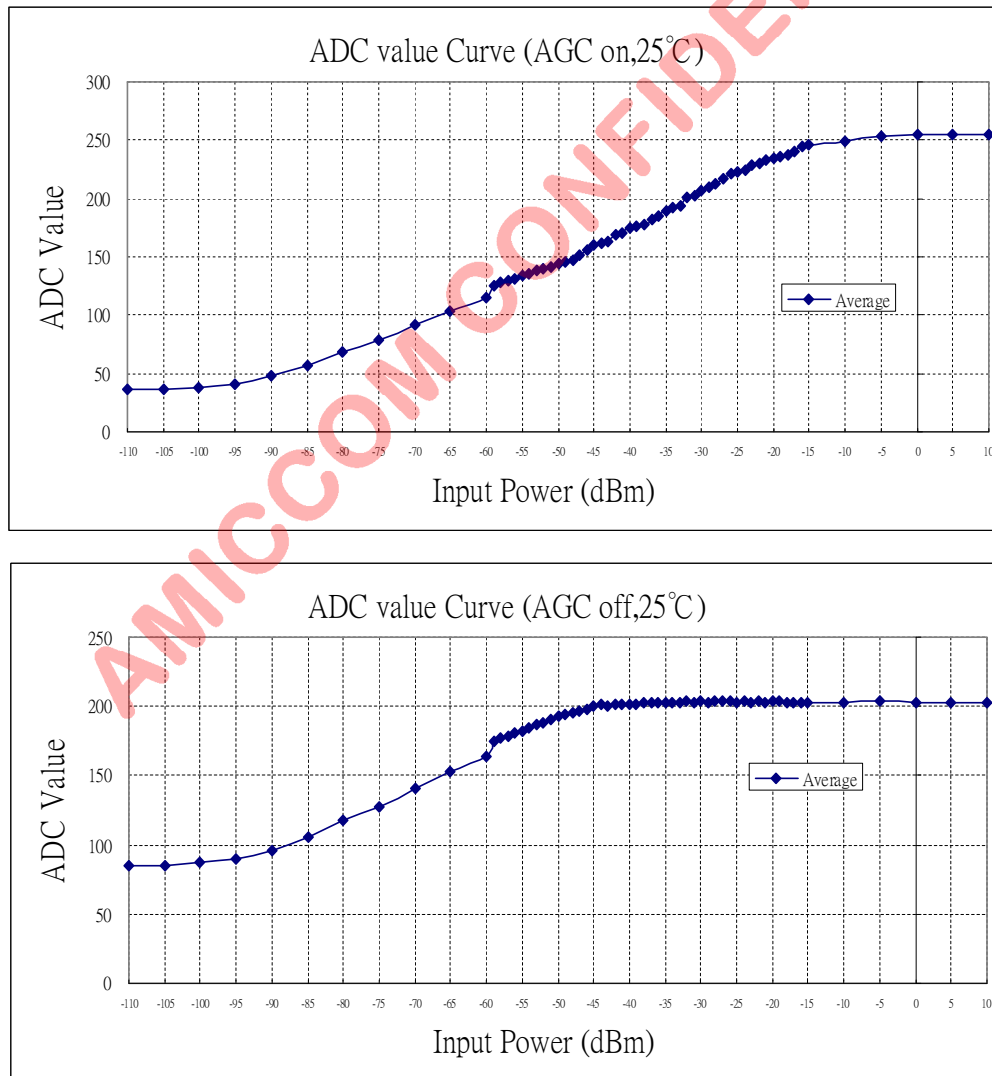

Figure 17.1 Typical RSSI characteristic

### Auto RSSI measurement for TX Power of the coming packet:

1. Set wanted  $F_{RXLO}$ .
2. Set recommend values of Table 17.1.
3. Enable ADCM = 1.
4. Send RX Strobe command.
5. Once frame sync (FSYNC) is detected or exiting RX mode, user can read digital RSSI value from ADC [7:0] for TX power of the coming packet.

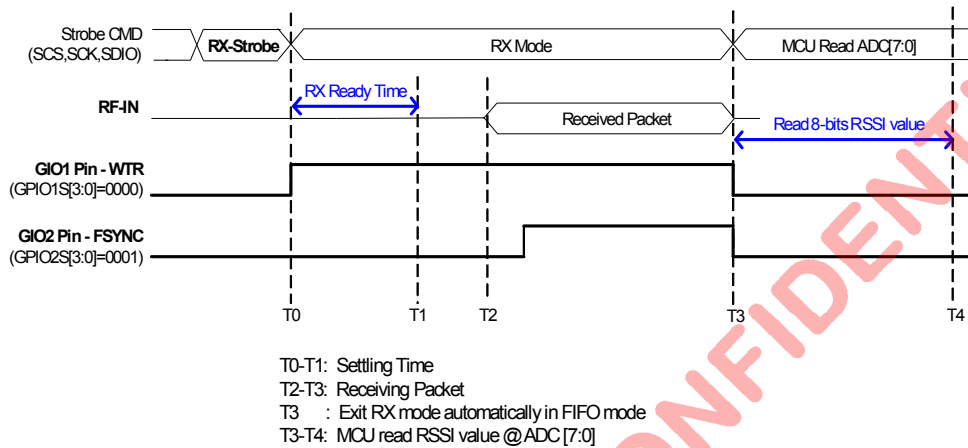

Figure 17.2 RSSI Measurement of TX RSSI of the coming packet.

### Auto RSSI measurement for Background Power:

1. Set wanted  $F_{RXLO}$ .
2. Set recommend values of Table 17.1.
3. Enable ADCM = 1.
4. Send RX Strobe command.
5. Stay in RX mode at least 140 us and then exiting RX mode. User can read digital RSSI value from ADC [7:0] for the background power.

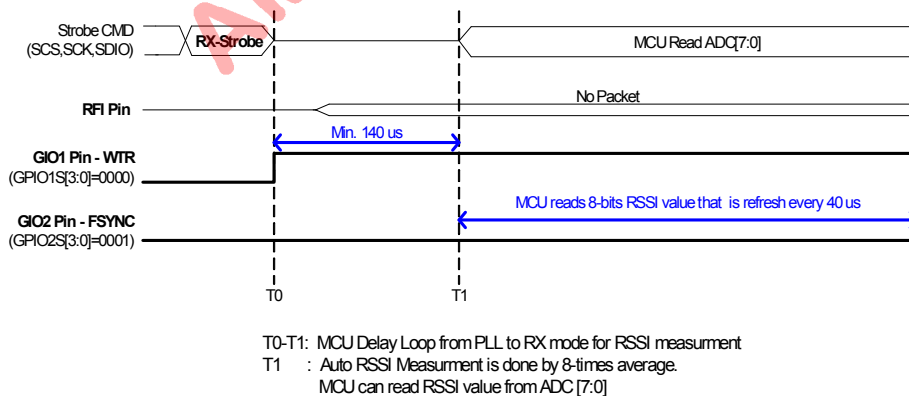

Figure 17.3 Measurement of Background RSSI.



## 18. Battery Detect

A7130 has a built-in battery detector to check supply voltage (REG1 pin). The detecting range is 2.0V ~ 2.7V into 8 levels.

Battery detect Register (Address: 2Ch)

Name	R/W	Bit 7	Bit 6	Bit 5	Bit 4	Bit 3	Bit 2	Bit 1	Bit 0
Battery detect	W	LVR	RGV1	RGV0	QDS	BVT2	BVT1	BVT0	BD_E
	R	--	RGV1	RGV0	BDF	BVT2	BVT1	BVT0	BD_E

**BVT [2:0]: Battery voltage detect threshold.**

[000]: 2.0V. [001]: 2.1V. [010]: 2.2V. [011]: 2.3V.

[100]: 2.4V. [101]: 2.5V. [110]: 2.6V. [111]: 2.7V.

**BD\_E: Battery Detect Enable.**

[0]: Disable. [1]: Enable. It will be clear after battery detection is triggered.

**BDF: Battery detection flag.**

[0]: Battery voltage less than threshold. [1]: Battery voltage greater than threshold.

**Below is the procedure to detect low voltage input (ex. below 2.1V):**

1. Set A7130 in standby or PLL mode.
2. Set BVT [2:0] = [001] and enable BD\_E = 1.
3. After 5 us, BD\_E is auto clear.
4. User can read BDF or output BDF to GIO1 pin or CKO pin.  
If REG1 pin > 2.1V,  
BDF = 1 (battery high). Else, BDF = 0 (battery low).

AMICCOM CONFIDENTIAL

**19. Auto-ack and auto-resend**

A7130 supports auto-resend and auto-ack scheme by enable EAK = 1 (auto-ack) and EAR = 1 (auto-resend). In application points of view, this feature is also ok to enable together with other feature options like FCB and/or EDRL (dynamic FIFO).

**19.1 Basic FIFO plus auto-ack auto-resend**

Set EAF = 0, EAK = 1 and EAR = 1 to enable auto-ack and auto-resend. Please refer to the below TX and ACK packet format of the sender and the receiver site respectively.

Sender Site (TX packet format)

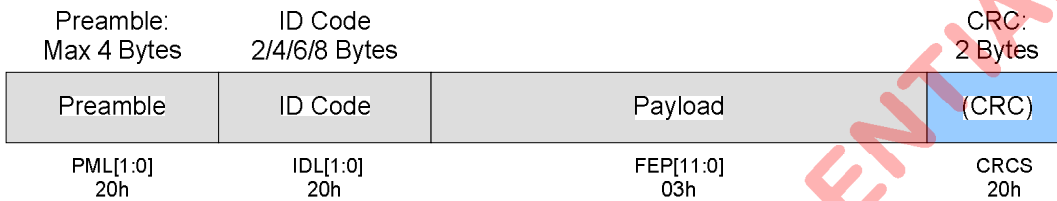

The sender will repeat transmitting the above TX packet based on setting of ARC (3Ah) until the sender receives the below ACK packet successfully.

Receiver Site (ACK packet format)

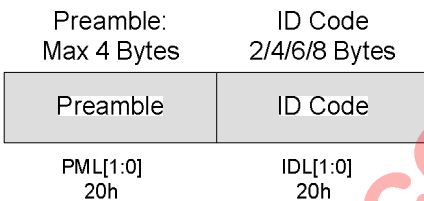

The receiver will automatically transmit the above ACK packet as long as the receiver gets the valid packet from the sender.

**19.2 Advanced FIFO plus auto-ack and auto-resend**

In addition to set EAF = 0, EAK = 1 and EAR = 1 to enable auto-ack and auto-resend. User can also enable an optional MAC header (FCB field) in the TX packet together with auto-ack and auto resend scheme. Please refer to the below TX and ACK packet format of the sender and the receiver site.

### Sender Site (TX packet format)

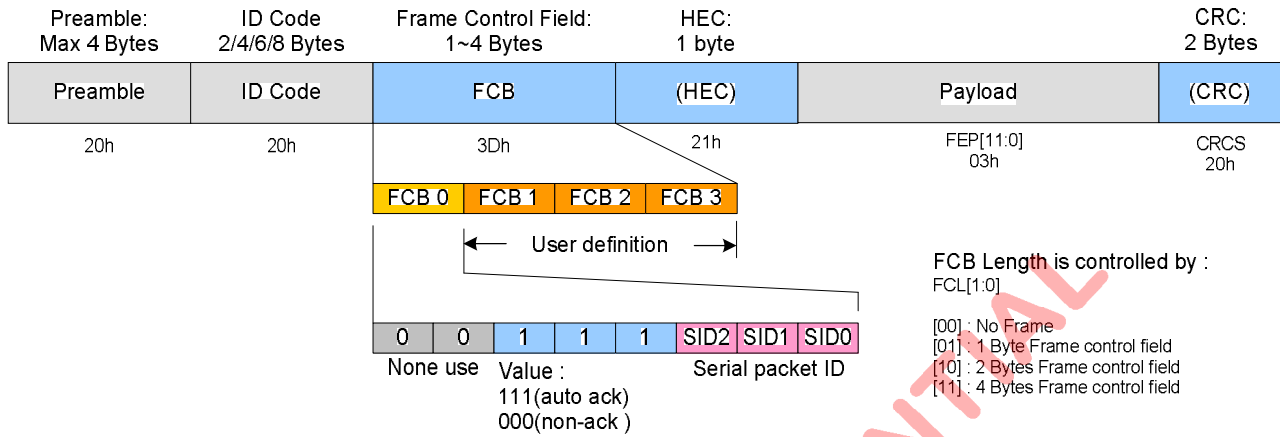

The sender will repeat transmitting the above TX packet based on setting of ARC (3Ah) until the sender receives the below ACK packet successfully.

### Receiver Site (ACK packet format)

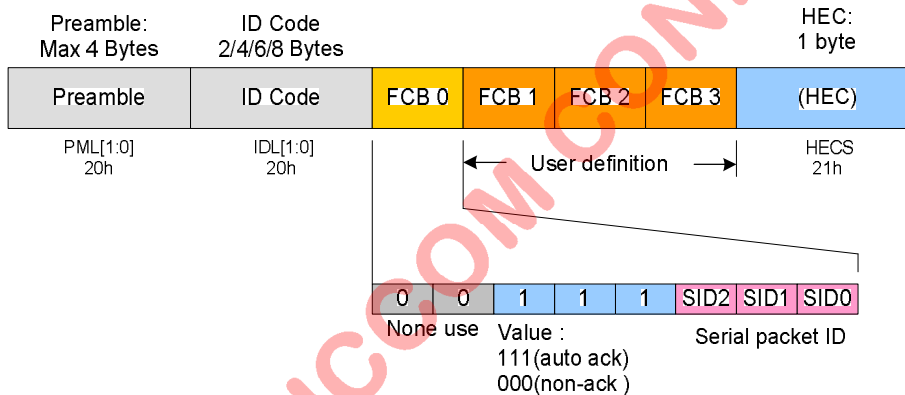

The receiver will automatically transmit the above ACK packet as long as the receiver gets the above valid packet from the sender.

## 19.3 WTR Behavior during auto-ack and auto-resend

If auto-ack and auto-resend are enabled (EAR = EAK = 1), WTR represents a completed transmission period and CWTR is a debug signal which represents the cyclic TX period and cyclic RX period. Please refer to the below timing diagrams for details.

### The sender site (auto-resend)

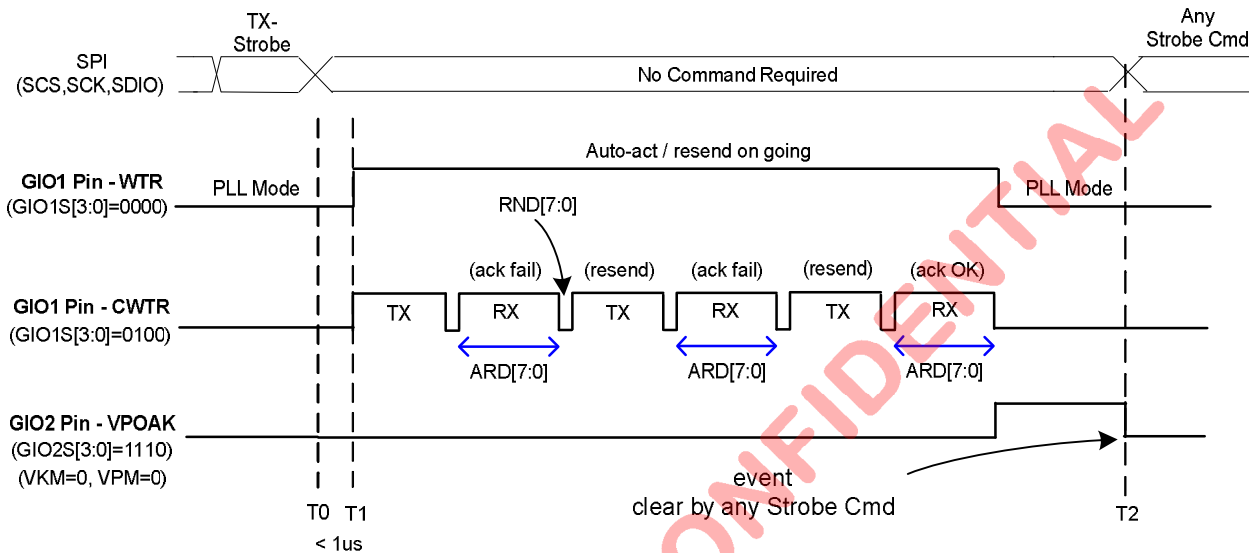

### The receiver site (auto-ack)

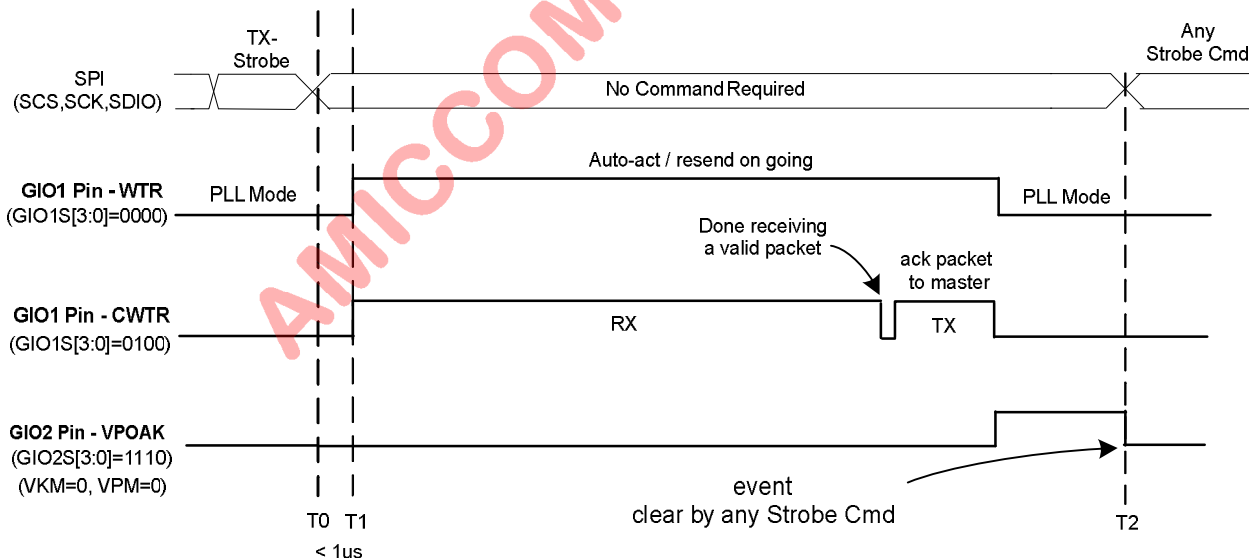

Remark: Refer to 3Bh for ARD[7:0] setting (auto resend delay).  
 Refer to 3Fh for RND[7:0] setting (random seed for resend interval).  
 Refer to 3Ah for EAK (enable auto-ack).  
 Refer to 3Ah for EAR (enable auto-resend).  
 Refer to 0Bh for VKM and VPM.

## 19.6 Examples of auto-ack and auto-resend

Once EAK and EAR are enabled, below case 1 ~ case 3 illustrate the most common cases as a timing reference (assume ARD = 800 us) in two ways radio communications.

<Case1> Always success

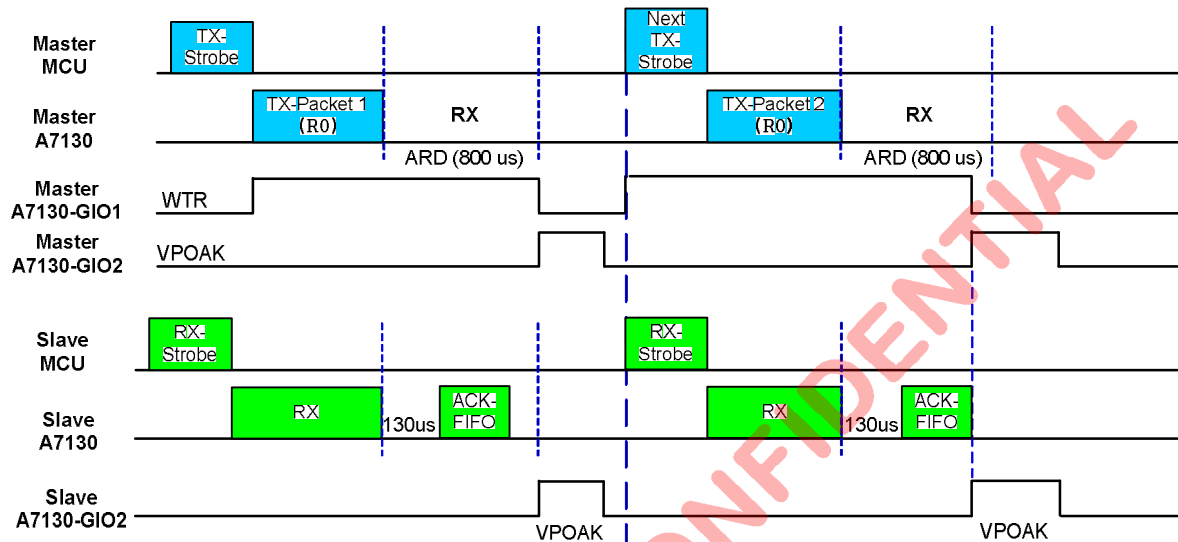

<Case2> Success in second packet

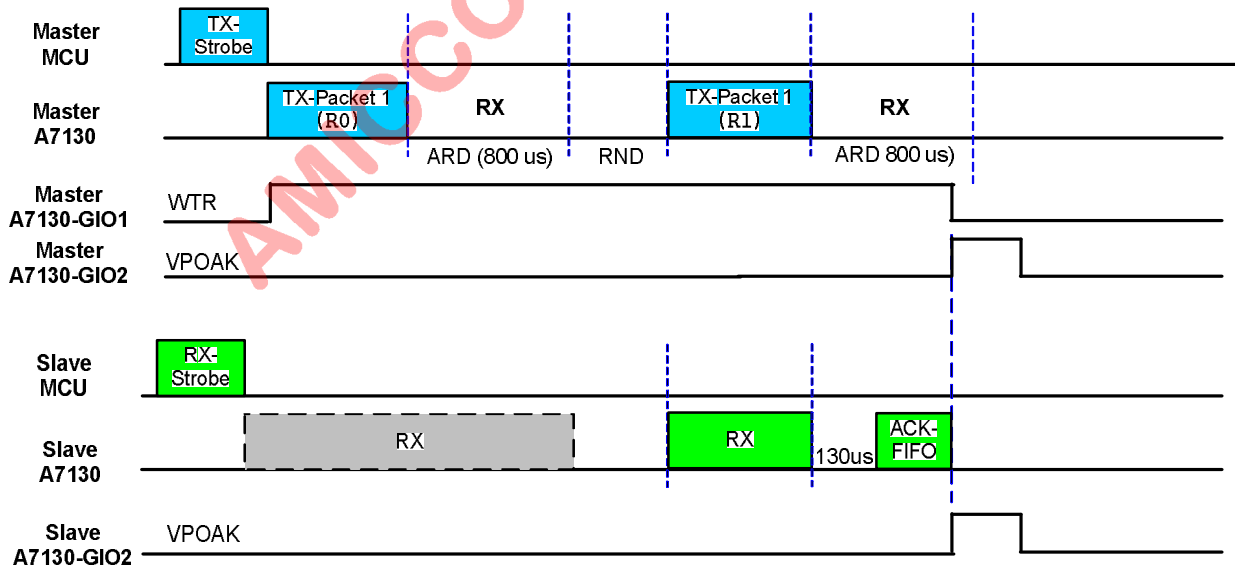

<Case3> always resend failure

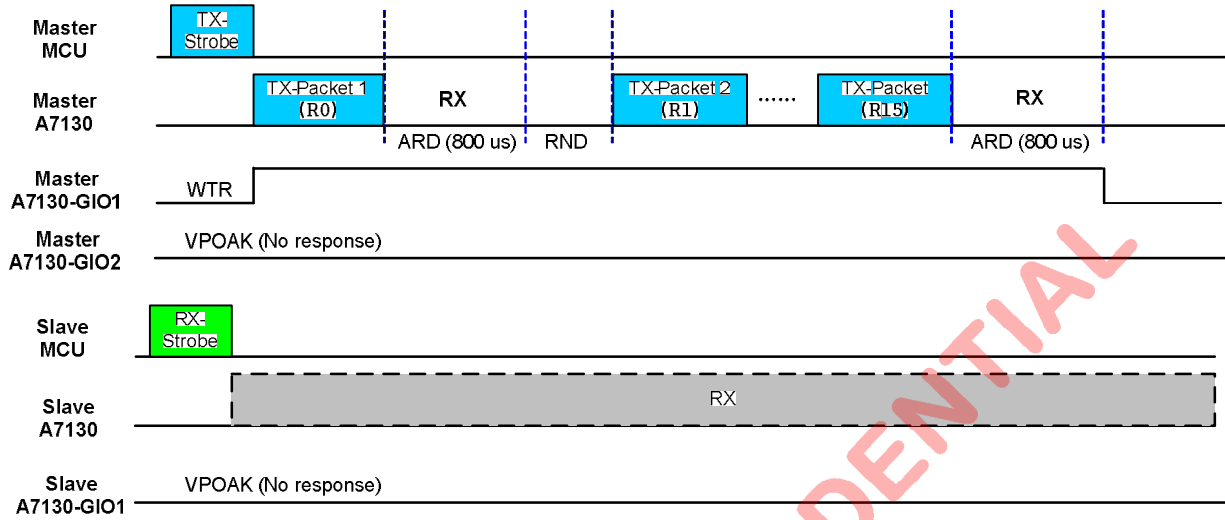

AMICCOM CONFIDENTIAL

## 20. RC Oscillator

A7130 has an internal RC oscillator to supports WOR (Wake On RX) and TWOR (Timer Wake On RX) function. RCOSC\_E (09h) is used to enable RC oscillator. WORE (01h) is used to enable WOR function and TWORE (09h) is used to enable TWOR function. After done calibrations of RC oscillator, WOR and TWOR function can be operated from -40°C to 85°C.

Parameter	Min	Max	Unit	Note
Calibrated Freq.	3.8K	4.2K	Hz	
Sleep period	7.82	8007.68	ms	$[(WOR\_SL [9:0]) + 1] \times 7.8 \text{ ms}$
RX period	0.244		ms	$[(WOR\_AC [5:0]) + 1] \times 244 \text{ us}$
Operation temperature	-40	85	°C	After calibration.

### 20.1 WOR Function

When WOR is enabled (WORE = 1 and RCOSC\_E =1), A7130 periodically wakes up from sleep and listen (auto-enter RX mode) for incoming packets without MCU interaction. Therefore, A7130 will stay in sleep mode based on WOR\_SL timer and RX mode based on WOR\_AC timer unless a packet is received.

The internal RC oscillator used for the WOR function varies with temperature and CMOS process deviation. In order to keep the frequency as accurate as possible, the RC oscillator shall be calibrated (CALWC=1) whenever possible. After done calibrations, MCU shall set WORE=1 and issue sleep strobe command to start WOR function. After a period (WOR\_SL) in sleep mode, the device goes to RX mode to check coming packets. And then, A7130 is back to sleep mode for the next WOR cycle. To end up WOR function, MCU just needs to set WORE = 0. Beware, please turn on MSCRC (21h, CRC data filtering) when CRCS = 1 (20h, CRC select) in WOR function.

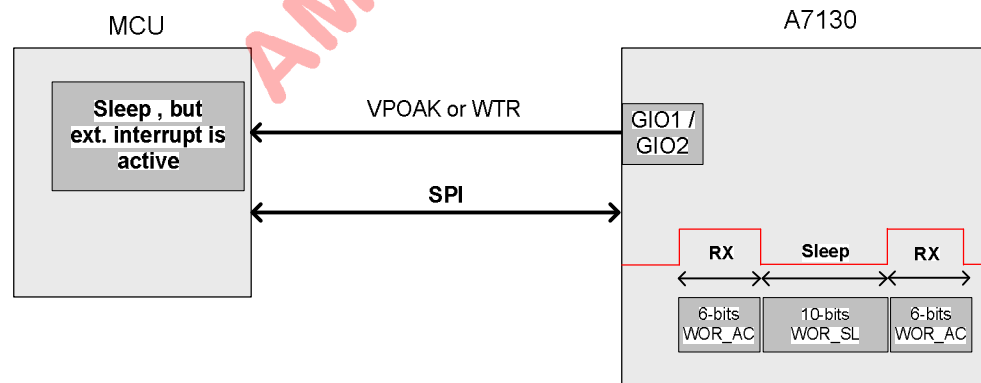
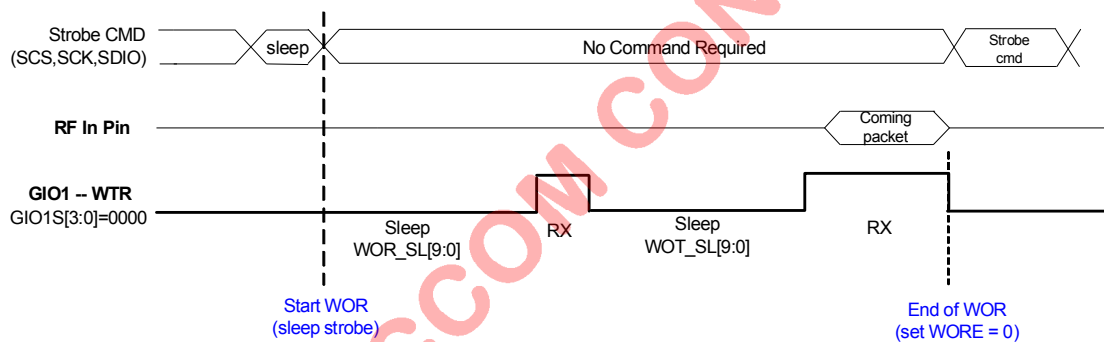

## 20.2 TWOR Function

The RC oscillator inside A7130 can also be used to support programmable TWOR (Timer Wake-On, TWORE=1) function which enables A7130 to output a periodic square wave from GIO1 (or GIO2). The duty cycle of this square wave is set by WOR\_AC (08h) or WOR\_SL (08h and 07h) regarding to TSEL (09h). User can use this square wave to wake up MCU or other purposes.

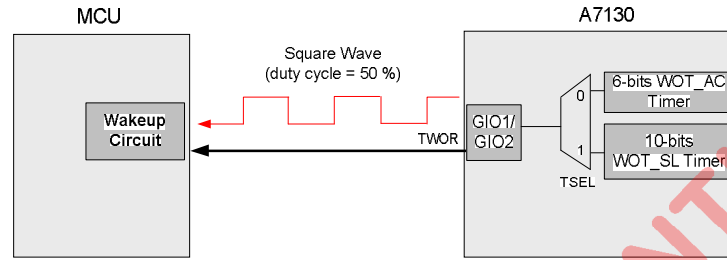

## 21. AES128 Security Packet

A7130 has a built-in AES128 co-processor to generate a security packet by a general purpose MCU. In addition to support 128-bits key length (AES128), A7130 also support a proprietary 32-bits key length called AES32.

### Software procedure to use AES128.

- Step1: Write 16-bytes AES128 key to KEYI [127:0] (36h)
- Step2: Set AESS=1 (3Eh) to select standard AES128
- Step3: Set AKFS=0 (3Eh) to disable attaching AES128 KEYI [127:0] into the TX packet.
- Step4: Set EDCRS=1 (3Eh) to enable AES co-processor.
- Step5: Write plain text to TX FIFO
- Step6: Issue TX strobe command and then A7130 will execute AES128 encryption and deliver the cipher text without latency.
- Step7: In RX side with the same configurations, A7130 will execute AES128 decryption and store plain text back to RX FIFO.

### Remark

1. The unit size of AES128 encryption packet is 16-bytes.
2. In TX side, if plain text is not dividable by 16-bytes, i.e. 5-bytes only, the TX packet is complement to be 16-bytes.
3. In RX side, the coming cipher text will be decrypted and restore 5-bytes plain text back to RX FIFO.

### Software procedure to use AES32.

- Step1: Write 4-bytes AES128 key to KEYI [31:0] (36h)
- Step2: Set AESS=0 (3Eh) to select proprietary AES32.
- Step3: Set AKFS=0 (3Eh) to not attach AES128 KEYI [31:0] to the wanted TX packet.
- Step4: Set EDCRS=1 (3Eh) to enable AES co-processor.
- Step5: Write plain text to TX FIFO
- Step6: Issue TX strobe command and then A7130 will execute AES32 encryption and deliver the cipher text without latency.
- Step7: In RX side with the same configurations, A7130 will execute AES32 decryption and store plain text back to RX FIFO.

### Remark

1. The unit size of AES32 encryption packet is 4-bytes.
2. In TX side, if plain text is not dividable by 4-bytes, i.e. 5-bytes only, the TX packet is complement to 8-bytes.
3. In RX side, the coming cipher text will be decrypted and restore 5-bytes plain text back to RX FIFO.



## 22. Application circuit

### 22.1 MD7% 0-A01

AMICCOM's ref. design module, MD7130-A01, max 5 dBm output power, application circuit example.

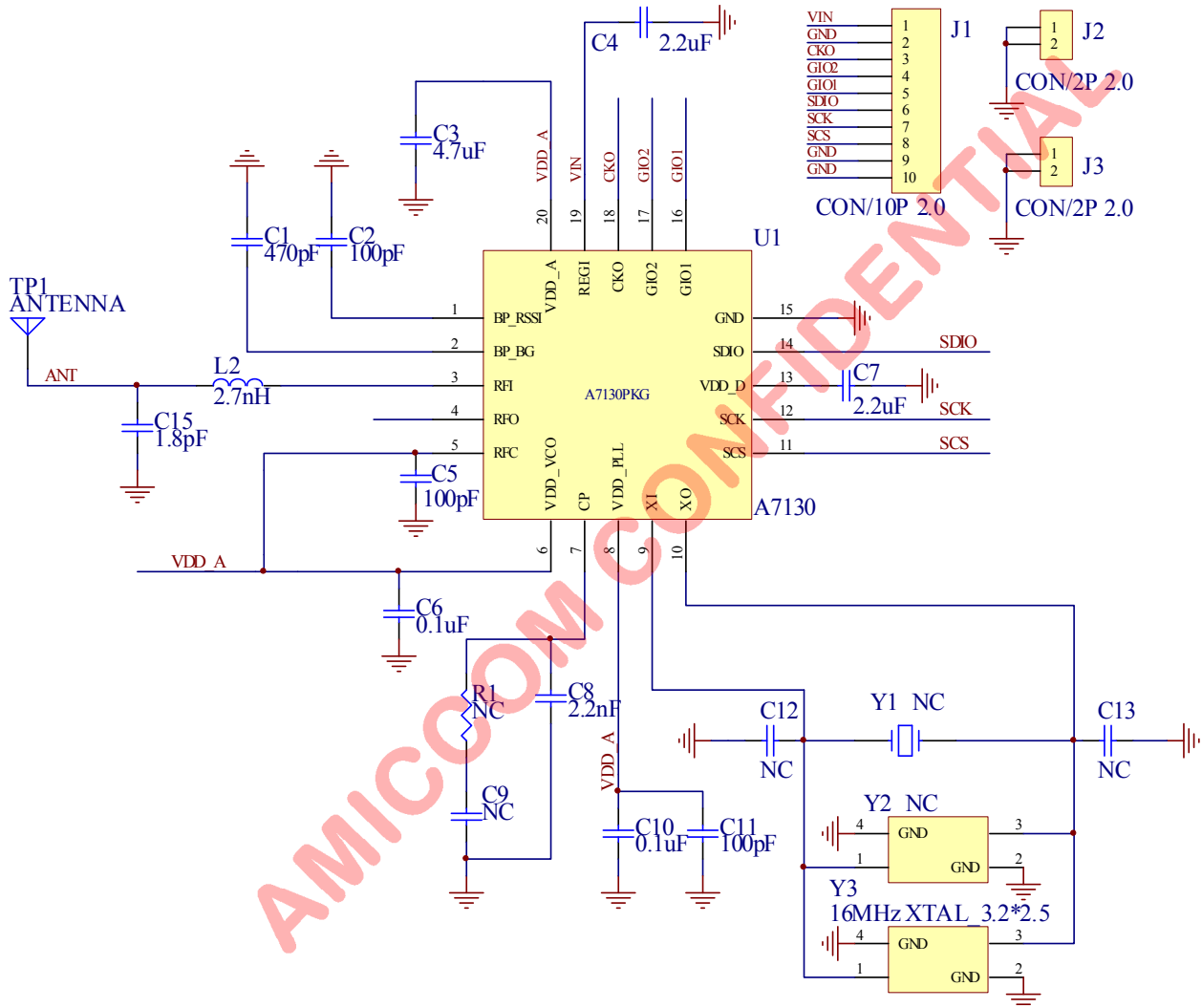

#### Remark

1. RF Matching to 50Ω.
2. RX and TX signal are combined internally to RFI pin only so that **RFSP bit = 0 (DASP0 register = 0x34)**.
3. Recommend 16MHz crystal with 18 pF Cloud.
4. Recommend to let C12 and C13 NC because of enabling on-chip Xtal Capacitors by (INTXC = 1 and CSXTAL = [10100]).



### 23. Abbreviations

ADC	Analog to Digital Converter
AIF	Auto IF
FC	Frequency Compensation
AGC	Automatic Gain Control
BER	Bit Error Rate
BW	Bandwidth
CD	Carrier Detect
CHSP	Channel Step
CRC	Cyclic Redundancy Check
DC	Direct Current
FEC	Forward Error Correction
FIFO	First in First out
FSK	Frequency Shift Keying
ID	Identifier
IF	Intermediate Frequency
ISM	Industrial, Scientific and Medical
LO	Local Oscillator
MCU	Micro Controller Unit
PFD	Phase Frequency Detector for PLL
PLL	Phase Lock Loop
POR	Power on Reset
RX	Receiver
RXLO	Receiver Local Oscillator
RSSI	Received Signal Strength Indicator
SPI	Serial to Parallel Interface
SYCK	System Clock for digital circuit
TX	Transmitter
TXRF	Transmitter Radio Frequency
VCO	Voltage Controlled Oscillator
XOSC	Crystal Oscillator
XREF	Crystal Reference frequency
XTAL	Crystal

### 24. Ordering Information

Part No.	Package	Units Per Reel / Tray
A71C30AQFI/Q	QFN20L, Pb Free, Tape & Reel, -40°C ~ 85°C	3K
A71C30AQFI	QFN20L, Pb Free, Tray, -40°C ~ 85°C	490EA
A71C30AH	Die form, -40°C ~ 85°C	100EA

## 25. Package Information

### QFN 20L (4 X 4 X 0.8mm) Outline Dimensions

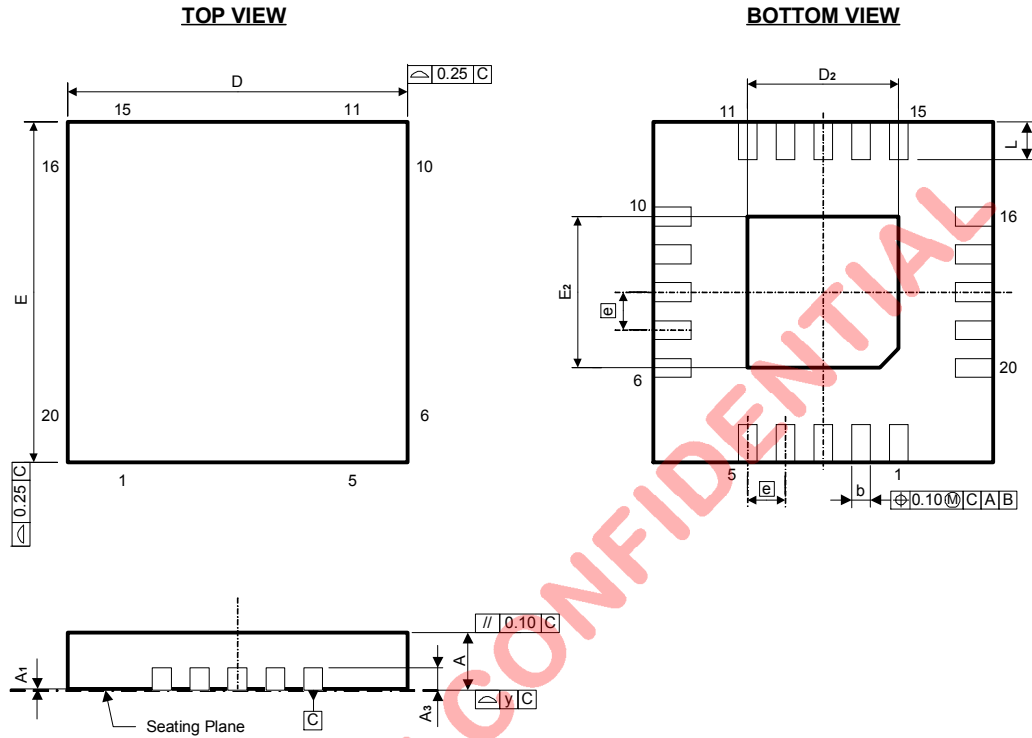

Symbol	Dimensions in inches			Dimensions in mm		
	Min	Nom	Max	Min	Nom	Max
A	0.028	0.030	0.032	0.70	0.75	0.80
A1	0.000	0.001	0.002	0.00	0.02	0.05
A3	0.008 REF			0.203 REF		
b	0.007	0.010	0.012	0.18	0.25	0.30
D	0.154	0.158	0.161	3.90	4.00	4.10
D2	0.075	0.079	0.083	1.90	2.00	2.10
E	0.154	0.158	0.161	3.90	4.00	4.10
E2	0.075	0.079	0.083	1.90	2.00	2.10
e	0.020 BSC			0.50 BSC		
L	0.012	0.016	0.020	0.30	0.40	0.50
y	0.003			0.08		

**26. Top Marking Information**

**A71C30AQFI**

- Part No. : **A71C30AQFI**
- Pin Count : **20**
- Package Type : **QFN**
- Dimension : **4\*4 mm**
- Mark Method : **Laser Mark**
- Character Type : **Arial**

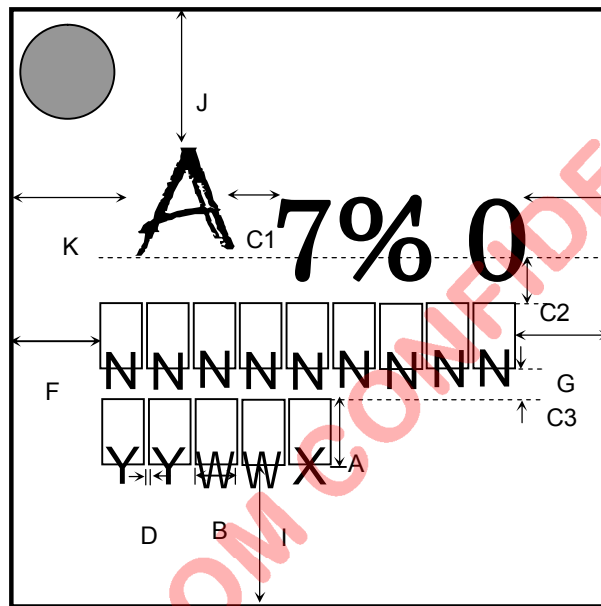

❖ CHARACTER SIZE : (Unit in mm)

**A : 0.55**  
**B : 0.36**  
**C1 : 0.25**      **C2 : 0.3**  
**C3 : 0.2**  
**D : 0.03**

**F=G**  
**I=J**  
**K=L**

**YYWW** : DATECODE  
**X** : PKG HOUSE  
**NNNNNNNN** : LOT NO.  
 (max. 9 characters)

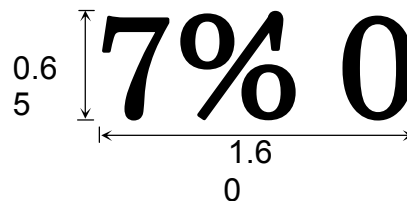
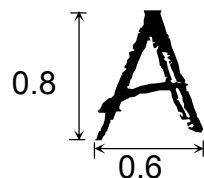

**27. Reflow Profile**

LEAD FREE (GREEN) PROFILE :

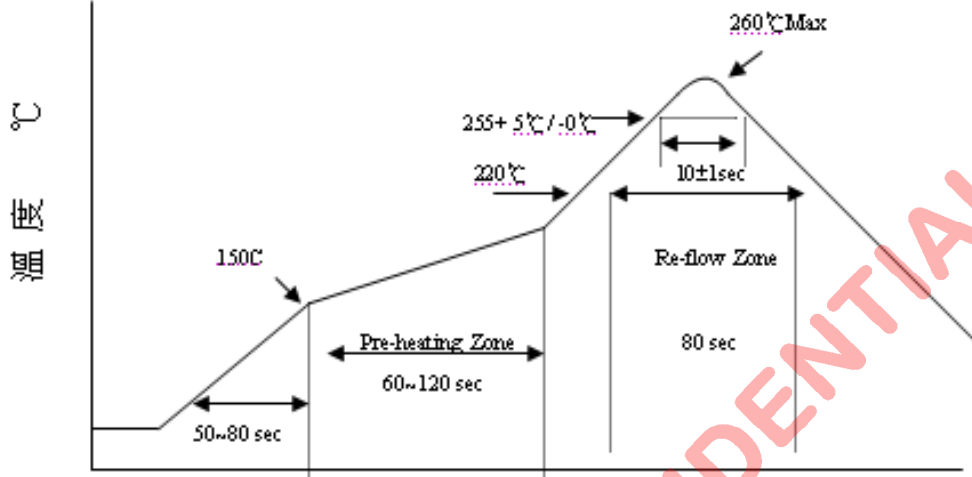

Actual Measurement Graph



**28. Tape Reel Information**

**Cover / Carrier Tape Dimension**

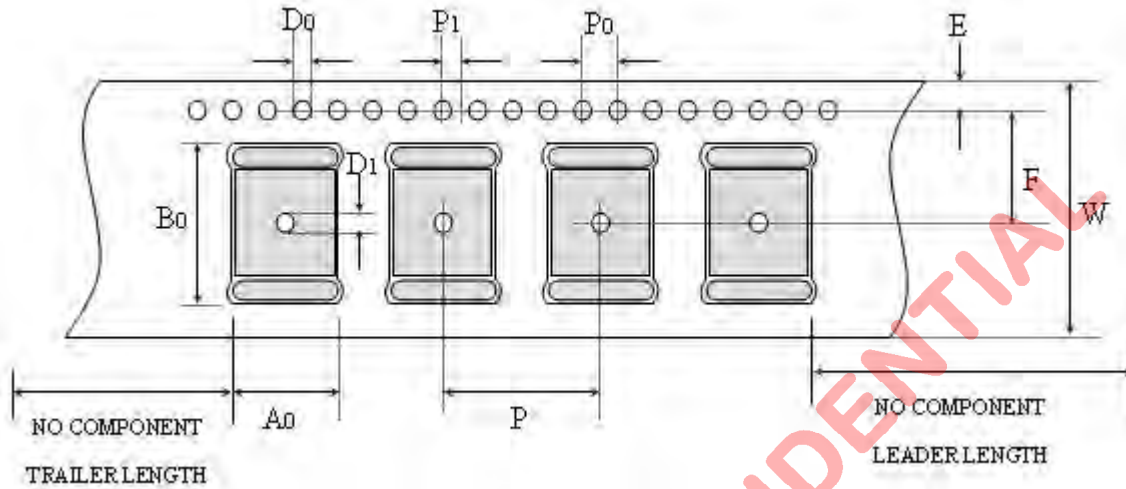

Unit: mm

TYPE	P	A0	B0	P0	P1	D0	D1	E	F	W
20 QFN 4*4	8	4.35	4.35	4.0	2.0	1.5	1.5	1.75	5.5	12
24 QFN 4*4	8	4.4	4.4	4.0	2.0	1.5	1.5	1.75	5.5	12
32 QFN 5*5	8	5.25	5.25	4.0	2.0	1.5	1.5	1.75	5.5	12
QFN3*3 / DFN-10	4	3.2	3.2	4.0	2.0	1.5	-	1.75	1.9	8
20 SSOP	12	8.2	7.5	4.0	2.0	1.5	1.5	1.75	7.5	16
24 SSOP	12	8.2	8.8	4.0	2.0	1.5	1.5	1.75	7.5	16

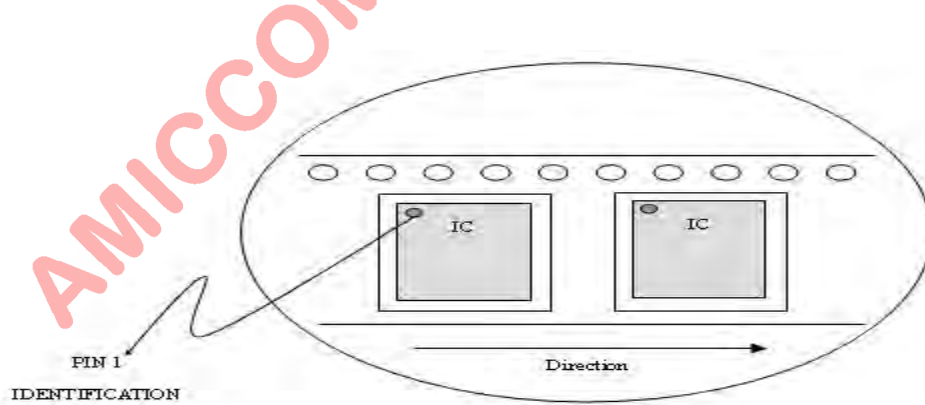
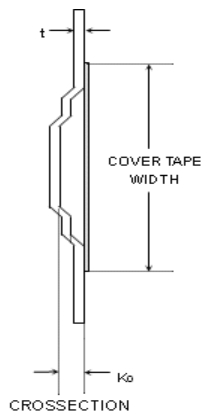

TYPE	K0	t	COVER TAPE WIDTH
20 QFN (4X4)	1.1	0.3	9.2
24 QFN (4X4)	1.4	0.3	9.2
32 QFN (5X5)	1.1	0.3	9.2
QFN3*3 / DFN-10	0.75	0.25	8
20 SSOP	2.5	0.3	13.3
24 SSOP	2.1	0.3	13.3

## REEL DIMENSIONS

UNIT IN mm

TYPE	G	N	T	M	D	K	L	R
20 QFN(4X4) 24 QFN(4X4) 32 QFN(5X5) DFN-10	12.8+0.6/-0.4	100 REF	18.2(MAX)	1.75±0.25	13.0+0.5/-0.2	2.0±0.5	330+ 0.00/-1.0	20.2
48 QFN(7X7)	16.8+0.6/-0.4	100 REF	22.2(MAX)	1.75±0.25	13.0+0.5/-0.2	2.0±0.5	330+ 0.00/-1.0	20.2
28 SSOP (150mil)	20.4+0.6/-0.4	100 REF	25(MAX)	1.75±0.25	13.0+0.5/-0.2	2.0±0.5	330+ 0.00/-1.0	20.2
20 SSOP 24 SSOP	16.4+2.0/-0.0	100 REF	22.4(MAX)	1.75±0.25	13.0+0.2/-0.2	1.9±0.4	330+ 0.00/-1.0	20.2

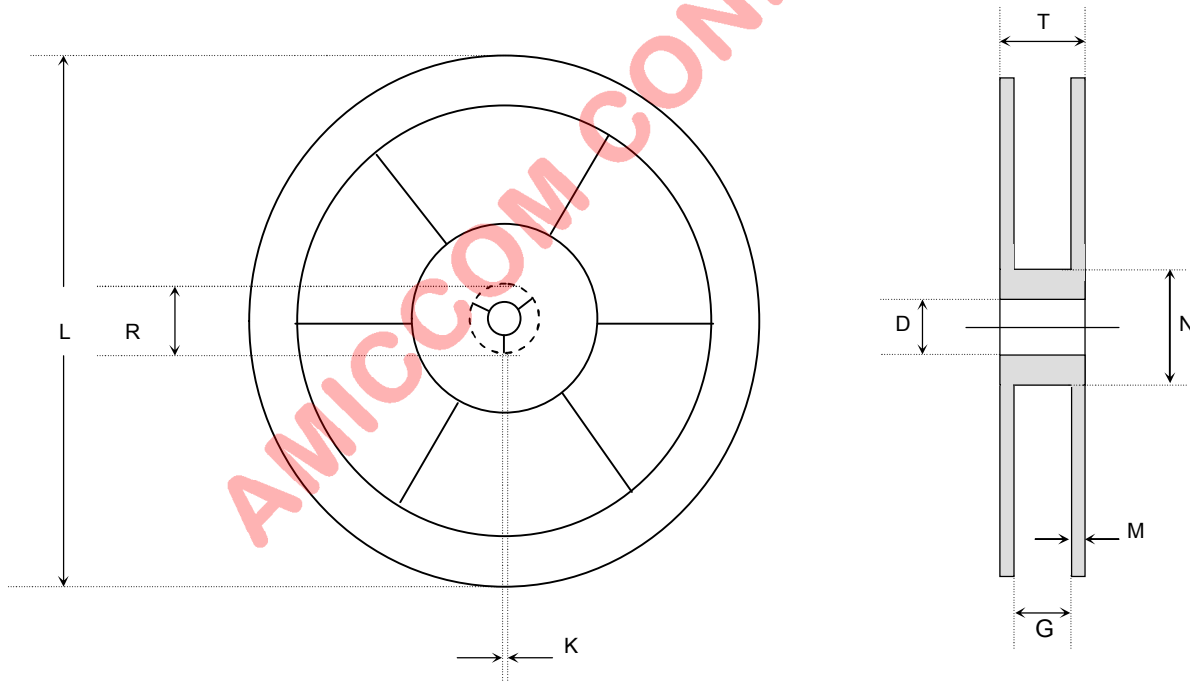



**29. Product Status**

Data Sheet Identification	Product Status	Definition
Objective	Planned or Under Development	This data sheet contains the design specifications for product development. Specifications may change in any manner without notice.
Preliminary	Engineering Samples and First Production	This data sheet contains preliminary data, and supplementary data will be published at a later date. AMICCOM reserves the right to make changes at any time without notice in order to improve design and supply the best possible product.
No Identification	Noted Full Production	This data sheet contains the final specifications. AMICCOM reserves the right to make changes at any time without notice in order to improve design and supply the best possible product.
Obsolete	Not In Production	This data sheet contains specifications on a product that has been discontinued by AMICCOM. The data sheet is printed for reference information only.

AMICCOM CONFIDENTIAL

**RF ICs AMICCOM**



**Headquarter**

A3, 1F, No.1, Li-Hsin Rd. 1, Hsinchu Science Park,  
Taiwan 30078  
Tel: 886-3-5785818

**Shenzhen Office**

Rm., 2003, DongFeng Building, No. 2010,  
Shennan Zhonglu Rd., Futian Dist., Shenzhen, China  
Post code: 518031

**Web Site**

<http://www.amiccom.com.tw>



Modular Approval:

The LBA 7130RF module is designed to comply with the FCC statement. FCC ID is OIE51402TR.

The host system using LBA 7130RF, should have label indicated FCC ID: OIE51402TR.

This radio module must not installed to co-locate and operating

Simultaneously with other radios in host system, additional testing

and equipment authorization may be required to operating simultaneously with other radio

**FCC Statement:**

1. This device complies with Part 15 of the FCC Rules. Operation is subject to the following two conditions:
  - (1)This device may not cause harmful interference, and
  - (2)This device must accept any interference received, including interference that may cause undesired operation.
2. Changes or modifications not expressly approved by the party responsible for compliance could void the user's authority to operate the equipment.