

PARTIAL-TEST REPORT
No.: 3-0019-11-6a

According to:
FCC Regulations
Part 15.209
IC Regulations
RSS-210, Issue 8
RSS-Gen, Issue 2

for
STRATTEC Security Corporation

Automotive RFID-CAN Based Immobilizer 5921714
FCC-ID: OHT5908933
ID: 5461A-5921714
+
RFID Antenna 5921980







Laboratory Accreditation and Listings			
 Deutsche Akkreditierungsstelle D-PL-12047-01-01	 FEDERAL COMMUNICATIONS COMMISSION USA Reg. No.: 736496 MRA US-EU 0003	 Industry Canada Reg. No.: 3462D-1 Reg. No.: 3462D-2 Reg. No.: 3462D-3	 Voluntary Controls for Electromagnetic Emissions Reg. No.: R-2665, R-2666 C-2914, T-1967, G-301
 AUTHORIZED RF LABORATORY	 LAB CODE 20011130-00		
accredited according to DIN EN ISO/IEC 17025			
<p align="center">CETECOM GmbH Laboratory Radio Communications & Electromagnetic Compatibility Im Teelbruch 116 • 45219 Essen • Germany Registered in Essen, Germany, Reg. No.: HRB Essen 8984 Tel.: + 49 (0) 20 54 / 95 19-954 • Fax: + 49 (0) 20 54 / 95 19-964 E-mail: info@cetecom.com • Internet: www.cetecom.com</p>			

Table of contents

1. SUMMARY OF TEST RESULTS	3
1.1. TESTS OVERVIEW FCC Part 15B/15C and Canada IC Standards (RSS-210).....	3
2. ADMINISTRATIVE DATA	4
2.1. Identification of the testing laboratory.....	4
2.2. Test location	4
2.3. Organizational items	4
2.4. Applicant’s details	4
2.5. Manufacturer’s details	4
3. EQUIPMENT UNDER TEST (EUT)	5
3.1. Additional declaration and description of main EUT	5
3.2. EUT: Type, S/N etc. and short descriptions used in this test report	5
3.3. Auxiliary Equipment (AE): Type, S/N etc. and short descriptions.....	6
3.4. EUT set-ups	6
3.5. Configuration of cables used for testing	6
3.6. EUT operating modes	6
4. DESCRIPTION OF TEST SET-UP’S	7
4.1. Set-up for conducted measurements	7
4.2. Test set-up for radiated measurements	7
5. MEASUREMENTS	8
5.1. Radiated emissions below 30 MHz §15.205 and §15.209, RSS210.....	8
5.2. Radiated emissions, 30 MHz - 1 GHz, §15.109 class B, §15.205 and §15.209, RSS210, RSS-gen.....	10
5.3. Occupied and emission bandwidth §2.104, RSS-Gen.	12
5.4. Measurement uncertainties	13
6. INSTRUMENTS AND ANCILLARY	14
6.1. Used equipment “CTC”	14
7. CORRECTION FACTORS DUE TO REDUCED MEAS. DISTANCE (F < 30 MHZ)	18

Table of annex

	Total pages
Annex TR3-0019-11-6a_A1: Measurement diagrams	6
Annex TR3-0019-11-6a _A2: EUT Photos	6
Annex TR3-0019-11-6a _A3: Measurement set-up photos	4

1. Summary of test results

The presented device for testing is a RFID CAN-based immobilizer working on TX/RX frequency of 124kHz. The unit is used as wireless access and key recognition system in automotive systems.

Following tests have been performed to show compliance with applicable FCC Part 2 and Part 15 (10-1-09 Edition) rules of the FCC CFR 47 and Industry Canada RSS-210, Issue 8 regulations. Based on these tests, a certification/approval for the device will be initiated.

The test results apply exclusively to the test samples as presented in chapter 3.1. The CETECOM GmbH does not assume responsibility for any conclusions and generalizations taken in conjunction with other specimens or samples of the type of the item presented to tests.

1.1. TESTS OVERVIEW FCC Part 15B/15C and Canada IC Standards (RSS-210)

TEST CASES	PORT	REFERENCES & LIMITS			EUT set-up	EUT operating mode	Result
		FCC Standard	RSS Section	Test limit			
TX-Mode							
RF-POWER radiated	Cabinet	§2.1046	RSS-210, Issue 8: Table 3	2400/F(kHz) μV/m	1	1	Passed
99% OCCUPIED BANDWIDTH	Antenna terminal (conducted)	§2.202 §2.1049	RSS Gen, Issue 2: chapter 4.6	99% Power	1	1	Passed
20dB BANDWIDTH	Antenna terminal (conducted)	§2.202 §2.1049	RSS Gen, Issue 2: chapter 4.6	20dBc	1	1	Not tested ¹⁾
SPURIOUS EMISSIONS (radiated)	Cabinet + Interconnecting cables (radiated)	§15.209(a)	RSS-Gen, Issue 2: chapter 4.9/4.11 RSS-210, Issue 8: Table 3	2400/F(kHz) μV/m 24000/F(kHz) μV/m 30 μV/m	1	1	Passed
FREQUENCY STABILITY	Antenna terminal (conducted)	§2.1055	RSS-Gen, Issue 2, chapter 4.5	Operation within band	--	--	Not tested ¹⁾
RX Mode							
RECEIVER Radiated emissions	Cabinet + Interconnecting cables (radiated)	§15.109 §15.33 §15.35	RSS-Gen, Issue 2: chapter 6(a)	FCC 15.109 class B limits IC-limits: Table 1, Chapter 6	1	1	Passed ²⁾

Remark: 1.) Only delta-testing were performed in accordance between applicant and laboratory.
2.) Performed as combined mode with TX.

ATTESTATION:

I declare that all measurements were performed by me or under my supervision and that all measurements have been performed and are correct to my best knowledge and belief to Industry Canada standards. All requirements as shown in above table are met in accordance with enumerated standards.

.....
Dipl.-Ing. Ch. Lorenz
Responsible for testsection

GmbH
Im Teelbruch 116
45219 Essen
Tel: + 49 (0) 20 54 795 19 - 0
Fax: + 49 (0) 20 54 795 19 - 267

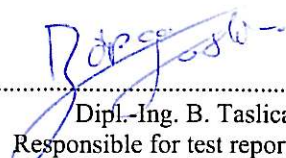
.....
Dipl.-Ing. B. Taslica
Responsible for test report

2. Administrative Data

2.1. Identification of the testing laboratory

Company name:	CETECOM GmbH
Address:	Im Teelbruch 116 45219 Essen - Kettwig Germany
Laboratory accreditations/Listings:	DAR-Registration No. DGA-PL-176/94-03 FCC-Registration No. 99538, MRA US-EU 0003 IC-Registration No. 3462D-1, 3462D-2 VCCI Registration No. R-2665,R-2666,C-2914,T-339
Responsible for testing laboratory:	Dipl.-Ing. W. Richter
Deputy:	Dipl.-Ing. J. Schmitt

2.2. Test location

2.2.1. Test laboratory "CTC"

Company name:	see chapter 2.1. Identification of the testing laboratory
---------------	---

2.3. Organizational items

Order No.:	34172
Responsible for test report and project leader:	Dipl.-Ing. B. Taslica
Receipt of EUT:	2011-10-14
Date(s) of test:	2011-10-20 – 2011-10-31
Date of report:	2011-11-03

Version of template:	09.06 _All.Dotm

2.4. Applicant's details

Applicant's name:	STRATTEC Security Corporation
Address:	3333 W. Good Hope Road Milwaukee WI 53209 USA
Contact person:	Mr. Michael Feucht

2.5. Manufacturer's details

Manufacturer's name:	please see Applicant's details
Address:	please see Applicant's details

3. Equipment under test (EUT)

3.1. Additional declaration and description of main EUT

Main function	Automotive RFID-CAN based immobilizer		
Type	5921714		
RFID	<input checked="" type="checkbox"/> passive	<input type="checkbox"/> active	
Frequency range (US/Canada -bands)	124.0kHz (fixed channel)		
Type of modulation	AM		
Number of channels (USA/Canada -bands)	1		
EMISSION DESIGNATOR(S)	2K02K1D (based on 99% occupied bandwidth measurements)		
Antenna Type	<input type="checkbox"/> Integrated <input checked="" type="checkbox"/> External air-core inductor, resonant over L-C-R circuit, no external RF- connector, resonant condition at 124kHz. <input type="checkbox"/> External, separate RF-connector		
Antenna Gain	No detailed information, part of the TX/RX system		
MAXIMUM field strength at nominal channel 3m distance corrected to 300m distance:	AV-value: -27,2 dBuV/m		
FCC-ID	OHT-5908933		
IC	5461A-5921714		
Power supply	12V DC nominal (automotive use)		
Special EMI components	--		
EUT sample type	<input type="checkbox"/> Production	<input checked="" type="checkbox"/> Pre-Production	<input type="checkbox"/> Engineering

3.2. EUT: Type, S/N etc. and short descriptions used in this test report

Short description*)	EUT	Type	S/N serial number	HW hardware status	SW software status
EUT A	Automotive RFID-CAN Based Immobilizer	5921714	#1	Prototype	MAC_MM-1-0
EUT B	RFID Antenna	5921980	#1	Prototype	-

*) EUT short description is used to simplify the identification of the EUT in this test report.

3.3. Auxiliary Equipment (AE): Type, S/N etc. and short descriptions

AE short description *)	Auxiliary Equipment	Type	S/N serial number	HW hardware status	SW software status
AE 1	RFID Key (valid) ¹⁾	PN #5921830	-	prototype	N.A.
AE 2	DUT exerciser	2)	#1	-	-
AE 3	Ignition switch ³⁾	N.A.	N.A.	N.A.	N.A.

1) Production intent RFID key.

2) Custom hardware build for laboratory test purposes of main EUT (control of EUT)

3) representative accessory needed to complete a functional representative EUT set-up

3.4.EUT set-ups

EUT set-up no. *)	Combination of EUT and AE	Remarks
Set. 1	EUT A + EUT B + AE 1 + AE 2 + AE 3	Representative set-up for test purposes

*) EUT set-up no. is used to simplify the identification of the EUT set-up in this test report.

3.5. Configuration of cables used for testing

Cable number	Item	Type	S/N serial number	HW hardware status	Cable length
Cable 1	Farant jumper1	Antenna stub connection between 'EUT A' and 'EUTB'	-	prototype	<3m
Cable 2	Power supply (12 V DC)	-	-	-	<3m
Cable 3	DUT exerciser (,AE 3'used only for testing) instead of control unit CAN BUS	CAN Bus , connection between ,EUT A' and ,AE 3'	-	-	<3m

3.6. EUT operating modes

EUT operating mode no. *)	Description of operating modes	Additional information
op. 1	TX-mode/ RX-mode	<p>For testing purposes a TX continuous modulated mode was implemented as the normal operation mode yields into a long time operating cycle. AE 1 therefore can be switched to more usable duty-cycle of the transmitter. The corresponding diagram in annex 1 shows the achieved shortest duty-cycle when AE1 is switched to CONT position. Also a plot is enclosed to show the original emission times.</p> <p>A valid key (passive RFID) was inserted into the car key socket and a recognition procedure (RX-mode) initiated. The valid result is showing a green LED light.</p> <p>As it is a RFID system, the TX and RX mode is performed near simultaneously. Therefore the results are showing both operating modes tested together like a system.</p>

*) EUT operating mode no. is used to simplify the test report.

4. DESCRIPTION OF TEST SET-UP's

4.1. Set-up for conducted measurements

Following modified test set-up schematic apply for tests performed inside the climatic chamber: (Frequency stability) Also it can be used for other tests like 99% occupied bandwidth or similar conducted tests.

In case **an external connector is not available on the EUT**, the coupling unit consists of a near-field small sized loop antenna which is directly connected to the spectrum analyzer. The power level calibration of the spectrum analyzer is related to the power levels (field strengths) of the carrier determined in the anechoic-chamber/ open-area test side.

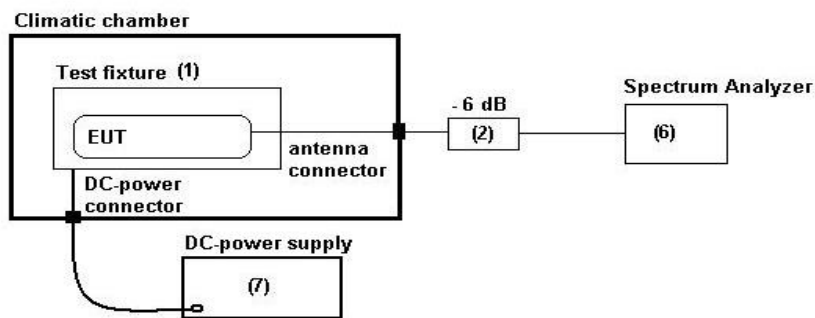

Schematic: Test set-up 2 conducted

4.2. Test set-up for radiated measurements

Pls. see above description and schematic for radiated measurements used set-up.

MEASUREMENT METHOD (30 MHz <math>f < 1 \text{ GHz}</math>):

A EMI analyzer together with a broadband antenna was used in order to identify the emissions from the EUT by positioning the antenna close to the EUT surfaces. The interconnecting cables and equipment position were varied in order to maximize the emissions. Then most critical frequencies are recorded for further investigations. Based on the exploratory measurements, the most critical frequencies are re-measured by maintaining the EUT's operating mode, cable position, etc. The EUT was placed on a non-conductive support of 0.8

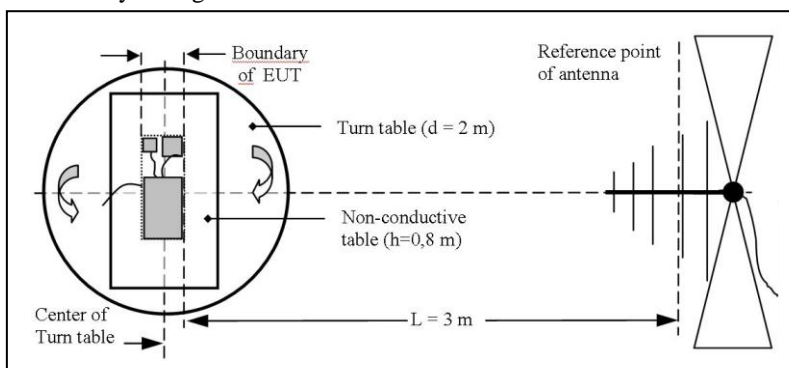

m height. By rotating the turntable angle in the range 0 to 360 degree, the EUT itself either over 3-orthogonal axis (not defined usage position) or 2-orthogonal axis (defined usage position) and the measurement antenna height from 1 meter to 4 meters, the maximized emissions are recorded. The measurements are performed for both polarizations of the measuring antenna: horizontal and vertical.

5. Measurements

5.1. Radiated emissions below 30 MHz

§15.205 and §15.209, RSS210

TEST LOCATION AND EQUIPMENT (for reference numbers please see chapter 'List of test equipment')

test location	<input checked="" type="checkbox"/> CETECOM Essen (Chapter. 2.2.1)	<input type="checkbox"/> Please see Chapter. 2.2.2		<input type="checkbox"/> Please see Chapter. 2.2.3	
test site	<input checked="" type="checkbox"/> 441 EMI SAR	<input type="checkbox"/> 487 SAR NSA	<input type="checkbox"/> 337 OATS	<input type="checkbox"/> 347 Radio.lab.	<input type="checkbox"/>
receiver	<input type="checkbox"/> 377 ESCS30	<input checked="" type="checkbox"/> 001 ESS	<input type="checkbox"/>	<input type="checkbox"/>	<input type="checkbox"/>
spectr. analys.	<input type="checkbox"/> 381 380 FSBS	<input type="checkbox"/> 120 FSEM	<input type="checkbox"/> 264 FSEK	<input type="checkbox"/>	<input type="checkbox"/>
antenna	<input type="checkbox"/> 048 EMCO3143	<input type="checkbox"/> 133 EMCO3115	<input type="checkbox"/> 302 BBHA9170	<input type="checkbox"/> 289 CBL 6141	<input checked="" type="checkbox"/> 030 HFH-Z2 <input type="checkbox"/> 477 GPS
signaling	<input type="checkbox"/> 298 CMU	<input type="checkbox"/> 460 CMU	<input type="checkbox"/> 295 RACAL	<input type="checkbox"/> 392 MT8820A	
power supply	<input type="checkbox"/> 456 EA 3013A	<input type="checkbox"/> 457 EA 3013A	<input type="checkbox"/> 459 EA 2032-50	<input type="checkbox"/> 268 EA- 3050	<input type="checkbox"/> 494 AG6632A <input type="checkbox"/> 498 NGPE 40
otherwise	<input type="checkbox"/> 400 FTC40x15E	<input type="checkbox"/> 401 FTC40x15E	<input type="checkbox"/> 110 USB LWL	<input type="checkbox"/> 482 Filter Matrix	

STANDARDS AND LIMITS: CFR 47, PART 15, SUBPART C, §15.205, §15.209, ANSI C63.10:2009

Frequency [MHz]	Field strength		Measurement distance [meters]	Remarks
	[µV/m]	[dBuV/m]		
0.009 – 0.490	2400/f (kHz)	67.6 – 20Log(f) (kHz)	300	Correction factor used due to measurement distance of 3m
0.490 – 1.705	24000/f (kHz)	87.6 – 20 Log(f) (kHz)	30	Correction factor used due to measurement distance of 3m
1.705 – 30	30	29.54	30	Correction factor used due to measurement distance of 3m

Remark: * decreases with the logarithm of the frequency

TEST CONDITION AND MEASUREMENT TEST SET-UP

link to test system (if used):	<input type="checkbox"/> air link	<input type="checkbox"/> cable connection	<input type="checkbox"/>
EUT-grounding	<input checked="" type="checkbox"/> none	<input type="checkbox"/> with power supply	<input type="checkbox"/> additional connection
Equipment set up	<input checked="" type="checkbox"/> table top		<input type="checkbox"/> floor standing
Climatic conditions	Temperature: (18°C)		Rel. humidity: (62)%
EMI-Receiver (Analyzer) Settings	Span/Range: 9kHz to 150kHz; 150 kHz to 30 MHz RBW/VBW: 200Hz/auto; 10 kHz/ auto (ANSI63.10/CISPR#16) Detector/ Mode: PEAK, TRACE max-hold mode, repetitive scan for exploratory measurements Quasi-Peak, for final measurement on critical frequencies (f<1GHz)		

GENERAL MEASUREMENT PROCEDURES:

The measurement test set-up and test procedure are in accordance with the provisions described in ANSI 63.10: 2009

The **Equipment under Test (EUT)** was set-up to defined operating mode and installed (connected) to accessory equipment according the general description of use given by the applicant.

The measurement loop antenna was situated in 3m distance to the EUT. Radiated magnetic emission measurements were made with the antenna situated in 1 meter height. The loop antenna was moved at least to 2-perpendicular axes (antenna vector in direction of EUT and parallel to EUT) in order to maximize the emissions, the EUT itself either over 3-orthogonal axes (no defined usage position) or 2-orthogonal axis (defined usage position) by the position manipulator.

According the standard the compliance should be checked in 30m and 300m measurement distance. Therefore a additional extrapolation factor was used in order to normalize the measurement data. The frequency dependent extrapolation factor used for this reduced measurement distance, can be found in the chapter annex 7.

MEASUREMENT RESULTS

1.)Carrier field-strength

Set-up No.		1										
Operating Mode		1										
Diagr. no. ¹⁾	Frequenc y (kHz)	Read MaxPeak/Average ¹⁾ (dBμV/m)	Meas Time (s)	Band - width (kHz)	Ant. height (cm)	Meas.- ment dist.	Pol. of Antenna - worst- case -	Angle of turn table -worst case-	Total Corr. (dB) (C _F)	Result Max-Peak Aver. (dB)	Mar- gin (M)	Limit (dBμV/m) (L _T)
-- (final measurement)	124.3 (carrier)	58.4 (PK) 41.5 (AV)	2	0.2	1m	3m ²⁾	Parallel to EUT	165°	+11.2 +0.1 -80 = -68.7	-10.3 (PK) -27.2 (AV)	53.05 (AV)	19,62 μV/m 25.85 dBuV/m

Remark: 1.) Please see at annex 1 the duty-cycle correction factor result.
 2.) Due to environmental outside noise level (low dynamic range), measurement have been performed in anechoic-chamber at 3m distance

2.)Harmonics of carrier field-strength

Set-up No.		1										
Operating Mode		1										
Diagr. no. ¹⁾	Freq. (kHz)	Read MaxPeak/Average (dBμV/m)	Meas Time (s)	Band - width (kHz)	Ant. height (cm)	Meas.- ment dist.	Pol. of Antenna	Angle of turn table	Total Corr. (dB) (C _F)	Margin (M)	Limit (dBμV/m) (L _T)	
3.01 (pre-measurement)	~380	<-59 (PK) <-74 (AV)	0.01	0.2	1m	3m	Parallel and 90° to EUT	0°..360°	see chpt. 7	< 74 (PK) < 89 (AV)	~15 dBuV/m	

Remark: 1.) Diagram 3.01 in annex 1 shows pre-measurement at carrier and around up to 500kHz.

Duty Cycle correction factor method: See Annex 1 'Duty-cycle at continuous TX-Mode'.

Duty cycle correction factor calculation expressed in terms of dB:

20*Log (On time/100 ms or period), whichever is less.

Calculations made for total correction transducer (C_F):

Conversion Factor due to unit dBuA/m to dBuV/m (+51.2dB if applicable) + Electric antenna conversion factor according antenna data sheet [dBuV]+ Cable loss [dB] + distance correction 300m to 3m (-80dB)

<p>Margin to Limit:</p> $M = L_T - R_R + C_F + D_F$ $= L_T - R_R + (AF_{ANTENNA} + Cable_{LOSS}) + D_F$ <p>Remark: positive margin means passed result</p>	<p>Abbreviations used:</p> <ul style="list-style-type: none"> • R_R : Receiver readings in dBμV/m • C_F: Transducer in dB = AF (antenna factor) + CL (cable loss) • D_F: distance correction factor (if different measurement distance used than specified in the standard) • L_T : Limit in dBμV/m
---	--

VERDICT

Summary of measurement results for radiated frequencies below 30 MHz: Passed

5.2. Radiated emissions, 30 MHz - 1 GHz, §15.109 class B, §15.205 and §15.209, RSS210, RSS-gen

TEST LOCATION AND EQUIPMENT (for reference numbers please see chapter 'List of test equipment')

test location	<input checked="" type="checkbox"/> CETECOM Essen (Chapter. 2.2.1)	<input type="checkbox"/> Please see Chapter. 2.2.2	<input type="checkbox"/> Please see Chapter. 2.2.3
test site	<input checked="" type="checkbox"/> 441 EMI SAR	<input type="checkbox"/> 487 SAR NSA	<input type="checkbox"/> 337 OATS
receiver	<input type="checkbox"/> 377 ESCS30	<input checked="" type="checkbox"/> 001 ESS	<input type="checkbox"/> 347 Radio.lab.
spectr. analys.	<input type="checkbox"/> 381 380 FSBS	<input type="checkbox"/> 120 FSEM	<input type="checkbox"/> 264 FSEK
antenna	<input type="checkbox"/> 048 EMCO3143	<input type="checkbox"/> 133 EMCO3115	<input type="checkbox"/> 302 BBHA9170
signaling	<input type="checkbox"/> 298 CMU	<input type="checkbox"/> 460 CMU	<input type="checkbox"/> 289 CBL 6141
power supply	<input type="checkbox"/> 295 RACAL	<input type="checkbox"/> 392 MT8820A	<input checked="" type="checkbox"/> 030 HFH-Z2
otherwise	<input type="checkbox"/> 456 EA 3013A	<input type="checkbox"/> 457 EA 3013A	<input type="checkbox"/> 477 GPS
	<input type="checkbox"/> 400 FTC40x15E	<input type="checkbox"/> 401 FTC40x15E	<input type="checkbox"/> 494 AG6632A
		<input type="checkbox"/> 110 USB LWL	<input type="checkbox"/> 498 NGPE 40
		<input checked="" type="checkbox"/> 482 Filter Matrix	

STANDARDS AND LIMITS: CFR 47, PART 15.109 CLASS B, §15.209, ANSI C63.10:2009

Frequency [MHz]	Radiated emission limits 3 meters	
	QUASI-Peak [microvolts/meter]	QUASI-Peak [dBµV/m]
30-88	100	40
88-216	150	43,5
216-960	200	46,0
above 960	500	54,0

TEST CONDITION AND MEASUREMENT TEST SET-UP

EUT-grounding	<input checked="" type="checkbox"/> none	<input type="checkbox"/> with power supply	<input type="checkbox"/> additional connection
Equipment set up	<input checked="" type="checkbox"/> table top 0.8m height	<input type="checkbox"/> floor standing	
Climatic conditions	Temperature: (22°C)	Rel. humidity: (61)%	
EMI-Receiver (Analyzer) Settings	Span/Range: 30 MHz to 1 GHz RBW/VBW: 120 kHz / (auto) Detector/ Mode: PEAK, TRACE max-hold mode, repetitive scan Quasi-Peak, for final measurement for critical measurements		

RESTRICTED BANDS OF OPERATION, §15.205

MHz	MHz	MHz	GHz
0.090-0.110	16.42-16.423	399.9-410	4.5-5.15
0.495-0.505	16.69475-16.69525	608-614	5.35-5.46
2.1735-2.1905	16.80425-16.80475	960-1240	7.25-7.75
4.125-4.128	25.5-25.67	1300-1427	8.025-8.5
4.20725-4.20775	37.5-38.25	1645.5-1646.5	9.3-9.5
6.215-6.218	73-74.6	1660-1710	10.6-12.7
6.26775-6.26825	74.8-75.2	1718.8-1722.2	13.25-13.4
6.31175-6.31225	108-121.94	2200-2300	14.47-14.5
8.291-8.294	123-138	2310-2390	15.35-16.2
8.362-8.366	149.9-150.05	2483.5-2500	17.7-21.4
8.37625-8.38675	156.52475-156.52525	2690-2900	22.01-23.12
8.41425-8.41475	156.7-156.9	3260-3267	23.6-24.0
12.29-12.293	162.0125-167.17	3332-3339	31.2-31.8
12.51975-12.52025	167.72-173.2	3345.8-3358	36.43-36.5
12.57675-12.57725	240-285	3600-4400	--
13.36-13.41	322-335.4	--	--

Remark: only spurious emissions are allowed within these frequency bands not exceeding the limits per §15.209

GENERAL MEASUREMENT PROCEDURES:

The measurement test set-up and test procedure are in accordance with the provisions described in ANSI 63.4: 2009 and ANSI63.10:2009

The *Equipment under Test* (EUT) set-up to defined operating mode and installed (connected) to accessory equipment according the general description of use given by the applicant.

MEASUREMENT METHOD (30 MHz<f <1 GHz)

See description in chapter 4.2

MEASUREMENT RESULTS

All results were under the general limits shown in §15.209. Therefore no split is made between frequencies falling inside restricted or outside the restricted bands.

Nominal Channel=125kHz

Set-up No.		1								
Operating Mode		1								
Diagram no. *)	Frequency (MHz)	Max QP (dBµV/m)	Meas. Time (ms)	Bandwidth (kHz)	Antenna height (cm)	Polarity	Turntable position (deg)	Corr. (dB) (C _F)	Margin (dB) (M)	Limit (dBµV/m) (L _T)
2.02	38.07	30.3	1000	120.000	368	H	85.0	18.2	9.7	40.0

Remark: *) The mentioned spurious emission above is selected as highest quasi-peak level. Please see the rest of the spurious emissions in the diagram 2.02, enclosed in annex 1.

<p>Margin to Limit:</p> $M = L_T - R_R + C_F + D_F$ $= L_T - R_R + (AF_{ANTENNA} + Cable_{LOSS}) + D_F$ <p>Remark: positive margin means passed result</p>	<p>Abbreviations used:</p> <ul style="list-style-type: none"> • R_R : Receiver readings in dBµV/m • CF: Transducer in dB = AF (antenna factor) + CL (cable loss) • D_F : distance correction factor (if different measurement distance used than specified in the standard) • L_T : Limit in dBµV/m
---	--

VERDICT

Summary of measurement results for radiated emissions above 30 MHz and below 1 GHz: Passed

5.3. Occupied and emission bandwidth

§2.104, RSS-Gen.

Test location and equipment (for reference numbers please see chapter 'List of test equipment')

test location	<input checked="" type="checkbox"/> CETECOM Essen (Chapter. 2.2.1)	<input type="checkbox"/> Please see Chapter. 2.2.2	<input type="checkbox"/> Please see Chapter. 2.2.3
test site	<input type="checkbox"/> 441 EMI SAR	<input type="checkbox"/> 487 SAR NSA	<input type="checkbox"/> 337 OATS
receiver	<input type="checkbox"/> 377 ESCS30	<input type="checkbox"/> 001 ESS	<input checked="" type="checkbox"/> 489 ESU
otherwise	<input checked="" type="checkbox"/> Near field loop antenna		<input type="checkbox"/> cable K15

REFERENCES: FCC: §2.104, IC:RSS-Gen: chapter 4.6, ANSI 63.10:2009

„the **occupied bandwidth** is the frequency bandwidth, such that, below it lower and above it upper frequency limits, the mean powers radiated are each equal to 0.5 percent of the total mean power radiated”

TEST SET-UP

see conducted measurement set-up described in 4.1

EUT SETTINGS:

The EUT was put to continuous transmit mode, modulated

SETTINGS OF THE SPECTRUM-ANALYSER

Parameter	Specific settings
Span	3..5 times the expected bandwidth
RBW (resolution bandwidth)	50 Hz (1..3% of the expected bandwidth)
VBW (video bandwidth)	3..10 times the RBW
Sweep time	coupled
Detector	PK, MAX-HOLD

TEST METHOD

Two markers are placed on frequency points such that left to lower frequency marker and right to higher frequency marker only 1% of the TX-power is contained. Between the markers, 99% of the power is laying. The used RBW is around 1%..3% of the EBW/OBW.

If applicable operating mode was varied in order to find worst-case. The occupied bandwidth should lie completely inside the allowed operational band of 110..495kHz.

RESULTS

Set-up 1, Op-Mode 1

Channel/ Frequency	Occupied 99% bandwidth [kHz]	26dBc Emission bandwidth [kHz]
Nominal Channel@ 124.13 kHz	2.02	--

Remarks:

5.4. Measurement uncertainties

The reported uncertainties are calculated based on the standard uncertainty multiplied with the appropriate coverage factor **k**, such that a confidence level of approximately 95% is achieved.

For uncertainty determination, each component used in the concrete measurement set-up was taken in account and it's contribution to the overall uncertainty according it's statistical distribution calculated.

Following table shows expectable uncertainties for each measurement type performed.

Measurement	Frequency range	Calculated uncertainty based on a confidence level of 95%	Remarks:
RF-Power Output conducted	9 kHz .. 20 GHz	1.0 dB	--
RF-Power Output radiated	30 MHz .. 4 GHz	3.17 dB	Substitution method
Conducted RF-emissions on antenna ports	9 kHz .. 20 GHz	1.0 dB	--
Radiated RF-emissions enclosure	150 kHz .. 30 MHz	5.0 dB	Magnetic field
	30 MHz .. 1 GHz	4.2 dB	E-Field
	1 GHz .. 18GHz	4.8 dB	E-Field
	1 GHz .. 20 GHz	3.17 dB	Substitution method
Occupied bandwidth	9 kHz .. 4 GHz	0.1272 ppm (Delta Marker method)	Frequency error
		1 dB	Power
Emission bandwidth	9 kHz .. 4 GHz	0.1272 ppm (Delta Marker method)	Frequency error
		1 dB	Power
Frequency stability	9 kHz .. 20 GHz	0.0636 ppm	--
Conducted emissions on AC-mains port (U _{CISPR})	9 kHz .. 150 kHz	4.0 dB	--
	150 kHz .. 30 MHz	3.6 dB	

Table : measurement uncertainties, valid for conducted/radiated measurements

6. Instruments and Ancillary

6.1. Used equipment “CTC”

The “Ref.-No” in the left column of the following tables allows the clear identification of the laboratory equipment.

6.1.1. Test software and firmware of equipment

Ref.-No.	Equipment	Type	Serial-No.	Version of Firmware or Software during the test
001	Emi Test Receiver	ESS	825132/017	Firm.= 1.21 , OTP=2.0, GRA=2.0
012	Signal Generator (EMS-cond.)	SMY 01	839069/027	Firm.= V 2.02
013	Power Meter (EMS cond.)	NRVD	839111/003	Firm.= V 1.51
017	Digital Radiocommunication Tester	CMD 60 M	844365/014	Firmware = V 3.52 .22.01.99, DECT = D2.87 13.01.99
053	Audio Analyzer	UPA3	860612/022	Firm. V 4,3
119	RT Harmonics Analyzer dig. Flickermeter	B10	G60547	Firm.= V 3.1DHG
140	Signal Generator	SMHU	831314/006	Firm.= 3.21
261	Thermal Power Sensor	NRV-Z55	825083/0008	EPROM-Datum 02.12.04, SE EE 1 B
262	Power Meter	NRV-S	825770/0010	Firm.= 2.6
263	Signal Generator	SMP 04	826190/0007	Firm.=3.21
264	Spectrum Analyzer	FSEK 30	826939/005	Bios=2.1, Analyzer= 3.20
295	Racal Digital Radio Test Set	6103	1572	UNIT Firmware= 4.04, SW-Main=4.04, SW-BBP=1.04, SW-DSP=1.02, Hardboot=1.02, Softboot=2.02
298	Univ. Radio Communication Tester	CMU 200	832221/091	R&S Test Firmware =3.53 /3.54 (current Testsoftw. f. all band used
323	Digital Radiocommunication Tester	CMD 55	825878/0034	Firm.= 3.52 .22.01.99
331	Climatic Test Chamber -40/+80 Grad	HC 4055	43146	TSI 1.53
335	System-CTC-EMS-Conducted	System EMS Conducted	-	EMC 32 V 8.40
340	Digital Radiocommunication Tester	CMD 55	849709/037	Firm.= 3.52 .22.01.99
355	Power Meter	URV 5	891310/027	Firm.= 1.31
365	10V Insertion Unit 50 Ohm	URV5-Z2	100880	Eprom Data = 31.03.08
366	Ultra Compact Simulator	UCS 500 M4	V0531100594	Firm. UCS 500=001925/3.06a02, rc=ISMIEC 4.10
371	Bluetooth Tester	CBT32	100153	CBT V5.30+ SW-Option K55
377	Emi Test Receiver	ESCS 30	100160	Firm.= 2.30, OTP= 02.01, GRA= 02.36
378	Broadband RF Field Monitor	RadiSense III	03D00013SNO-08	Firm.= V.03D13
383	Signal Generator	SME 03	842 828 /034	Firm.= 4.61
389	Digital Multimeter	Keithley 2000	0583926	Firm. = A13 (Mainboard) A02 (Display)
392	Radio Communication Tester	MT8820A	6K00000788	Firm.= 4.50 #005, IPL=4.01#001,OS=4.02#001, GSM=4.41#013, W-CDMA= 4.54#004, scenario= 4.52#002
436	Univ. Radio Communication Tester	CMU 200	103083	R&S Test Firmware Base=5.14, Mess-Software= GSM:5.14 WCDMA:5.14 (current Testsoftw. F. all band to be used ,
441	CTC-SAR-EMI Cable Loss	System EMI field (SAR) Cable	-	EMC 32 Version 8.40
442	CTC-SAR-EMS	System EMS field (SAR)	-	EMC 32 Version 8.40
443	CTC-FAR-EMI-RSE	System CTC-FAR-EMI-RSE	-	Spuri 7.2.5 or EMC 32 Ver. 8.40
444	CTC-FAR-EMS field	System-EMS-Field (FAR)	-	EMC 32 Version 8.40
460	Univ. Radio Communication Tester	CMU 200	108901	R&S Test Firmware Base=5.14, GSM=5.14 WCDMA=5.14 (current Testsoftw.,f. all band to be used,
489	Emi Test Receiver	ESU40	1000-30	Firmware=4.43 SP3, Bios=V5.1-16-3, Spec. =01.00
491	ESD Simulator dito	ESD dito	dito307022	V 2.30
524	Voltage Drop Simulator	VDS 200	0196-16	Software Nr. 000037 Version V4.20a01
526	Burst Generator	EFT 200 A	0496-06	Software Nr. 000034 Version V2.32
527	Micro Pulse Generator	MPG 200 B	0496-05	Software-Nr. 000030 Version V2.43
528	Load Dump Simulator	LD 200B	0496-06	Software-Nr. 000031 Version V2.35a01
546	Univ. Radio Communication Tester	CMU 200	106436	R&S Test Firmware Base=5.14, GSM=5.14 WCDMA=5.14 (current Testsoftw.,f. all band to be used
547	Univ. Radio Communication Tester	CMU 200	835390/014	R&S Test Firmware Base=V5.1403 (current Testsoftw., f. all band used, GSM = 5.14 WCDMA: = 5.14
584	Spectrum Analyzer	FSU 8	100248	2.82_SP3
594	Univ. Radio Communication Tester	CMW500	101757	Firmware Base=2.0.20.9, LTE=2.0.20.8. CDMA= 2.0.10
597	Univ. Radio Communication Tester	CMU 200	100347	R&S Test Firmware Base=5.01, GSM=5.02 WCDMA= not installed, Mainboard= µP1=V.850
598	Spectrum Analyzer	FSEM 30 (Reserve)	831259/013	Firmware Bios 3.40 , Analyzer 3.40 Sp 2

6.1.2. Single instruments and test systems

Ref.-No.	Equipment	Type	Serial-No.	Manufacturer	Interval of calibration	Remark	Cal due
001	Emi Test Receiver	ESS	825132/017	Rohde & Schwarz	12 M	-	31.03.2012
005	AC - LISN (50 Ohm/50µH, test site 1)	ESH2-Z5	861741/005	Rohde & Schwarz	24/12 M	-	31.03.2012
007	DC - LISN (50 Ohm/5µH)	ESH3-Z6	892563/002	Rohde & Schwarz	24/12 M	-	31.03.2012
009	Power Meter (EMS-radiated)	NRV	863056/017	Rohde & Schwarz	24 M	-	31.03.2013
016	Line Impedance Simulating Network	Op. 24-D	B6366	Spitzenberger+Spies	36 M	-	31.03.2013
020	Horn Antenna 18 GHz (Subst 1)	3115	9107-3699	EMCO	36/12 M	-	31.03.2013
021	Loop Antenna (H-Field)	6502	9206-2770	EMCO	36 M	-	31.03.2013
030	Loop Antenna (H-field)	HFH-Z2	879604/026	Rohde & Schwarz	36 M	-	31.03.2012
033	RF-current probe (100kHz-30MHz)	ESH2-Z1	879581/18	Rohde & Schwarz	24 M	-	31.03.2013
057	relay-switch-unit (EMS system)	RSU	494440/002	Rohde & Schwarz	pre-m	1a	
060	power amplifier (DC-2kHz)	PAS 5000	B6363	Spitzenberger+Spies	-	3	
066	notch filter (WCDMA; FDD1)	WRCT 1900/2200-5/40-10EEK	5	Wainwright GmbH	12 M	1c	30.06.2012
086	DC - power supply, 0 -10 A	LNG 50-10	-	Heinzinger Electronic	pre-m	2	
087	DC - power supply, 0 -5 A	EA-3013 S	-	Elektro Automatik	pre-m	2	
090	Helmholtz coil: 2x10 coils in series	-	-	RWTÜV	-	4	
091	USB-LWL-Converter	OLS-1	007/2006	Ing. Büro Scheiba	-	4	
099	passive voltage probe	ESH2-Z3	299.7810.52	Rohde & Schwarz	36 M	-	31.03.2012
100	passive voltage probe	Probe TK 9416	without	Schwarzbeck	36 M	-	31.03.2012
110	USB-LWL-Converter	OLS-1	-	Ing. Büro Scheiba	-	4	
119	RT Harmonics Analyzer dig. Flickermeter	B10	G60547	BOCONSULT	36 M	-	31.03.2013
134	horn antenna 18 GHz (Subst 2)	3115	9005-3414	EMCO	12 M	-	31.03.2012
136	adjustable dipole antenna (Dipole 1)	3121C-DB4	9105-0697	EMCO	12 M	-	31.03.2012
140	Signal Generator	SMHU	831314/006	Rohde & Schwarz	24 M	-	31.03.2012
248	attenuator	SMA 6dB 2W	-	Radiall	pre-m	2	
249	attenuator	SMA 10dB 10W	-	Radiall	pre-m	2	
252	attenuator	N 6dB 12W	-	Radiall	pre-m	2	
256	attenuator	SMA 3dB 2W	-	Radiall	pre-m	2	
257	hybrid	4031C	04491	Narda	pre-m	2	
260	hybrid coupler	4032C	11342	Narda	pre-m	2	
261	Thermal Power Sensor	NRV-Z55	825083/0008	Rohde & Schwarz	24/12 M	-	31.03.2012
262	Power Meter	NRV-S	825770/0010	Rohde & Schwarz	24 M	-	31.03.2012
263	Signal Generator	SMP 04	826190/0007	Rohde & Schwarz	36 M	-	31.03.2013
264	Spectrum Analyzer	FSEK 30	826939/005	Rohde & Schwarz	12 M	-	31.03.2014
265	peak power sensor	NRV-Z33, Model 04	840414/009	Rohde & Schwarz	24 M	-	31.03.2012
266	peak power sensor	NRV-Z31, Model 04	843383/016	Rohde & Schwarz	24 M	-	31.03.2012
267	notch filter GSM 850	WRCA 800/960-6EEK	9	Wainwright GmbH	pre-m	2	
268	AC/DC power supply	EA 3050-A	9823636	Elektro Automatik	pre-m	2	
270	termination	1418 N	BB6935	Weinschel	pre-m	2	
271	termination	1418 N	BE6384	Weinschel	pre-m	2	
272	attenuator (20 dB) 50 W	Model 47	BF6239	Weinschel	pre-m	2	
273	attenuator (10 dB) 100 W	Model 48	BF9229	Weinschel	pre-m	2	
274	attenuator (10 dB) 50 W	Model 47 (10 dB) 50 W	BG0321	Weinschel	pre-m	2	
275	DC-Block	Model 7003 (N)	C5129	Weinschel	pre-m	2	
276	DC-Block	Model 7006 (SMA)	C7061	Weinschel	pre-m	2	
279	power divider	1515 (SMA)	LH855	Weinschel	pre-m	2	
287	pre-amplifier 25MHz - 4GHz	AMF-2D-100M4G-35-10P	379418	Miteq	12 M	1c	30.06.2012
291	high pass filter GSM 850/900	WHJ 2200-4EE	14	Wainwright GmbH	12 M	1c	30.06.2012
298	Univ. Radio Communication Tester	CMU 200	832221/091	Rohde & Schwarz	pre-m	3	
300	AC LISN (50 Ohm/50µH, 1-phase)	ESH3-Z5	892 239/020	Rohde & Schwarz	24/12 M	-	31.03.2012
301	attenuator (20 dB) 50W, 18GHz	47-20-33	AW0272	Lucas Weinschel	pre-m	2	
302	horn antenna 40 GHz (Meas 1)	BBHA9170	155	Schwarzbeck	36 M	-	31.03.2014
303	horn antenna 40 GHz (Subst 1)	BBHA9170	156	Schwarzbeck	36 M	-	31.03.2014
331	Climatic Test Chamber -40/+80 Grad	HC 4055	43146	Heraeus Vötsch	24 M	-	30.11.2012
341	Digital Multimeter	Fluke 112	81650455	Fluke	24 M	-	31.03.2012
342	Digital Multimeter	Voltcraft M-4660A	IB 255466	Voltcraft	24 M	-	31.03.2013
347	laboratory site	radio lab.	-	-	-	5	
348	laboratory site	EMI conducted	-	-	-	5	
354	DC - Power Supply 40A	NGPE 40/40	448	Rohde & Schwarz	pre-m	2	
355	Power Meter	URV 5	891310/027	Rohde & Schwarz	24 M	-	31.03.2012
356	power sensor	NRV-Z1	882322/014	Rohde & Schwarz	24 M	-	31.03.2013
357	power sensor	NRV-Z1	861761/002	Rohde & Schwarz	24 M	-	31.03.2013
373	V-Network 5µH/50 Ohm	ESH3-Z6	100535	Rohde & Schwarz	24/12 M	-	31.03.2012
376	Horn Antenna 6 GHz	BBHA9120 E	BBHA 9120 E.179	Schwarzbeck	12 M	-	31.03.2012
377	Emi Test Receiver	ESCS 30	100160	Rohde & Schwarz	12 M	-	31.03.2012
389	Digital Multimeter	Keithley 2000	0583926	Keithley	24 M	-	31.03.2013
392	Radio Communication Tester	MT8820A	6K00000788	Anritsu	12 M	-	31.03.2012
431	Model 7405	Near-Field Probe Set	9305-2457	EMCO	-	4	
436	Univ. Radio Communication Tester	CMU 200	103083	Rohde & Schwarz	12 M	-	31.03.2012
441	CTC-SAR-EMI Cable Loss	System EMI field (SAR) Cable	-	CETECOM	12 M	5	31.10.2012

Ref.-No.	Equipment	Type	Serial-No.	Manufacturer	Interval of calibration	Remark	Cal due
443	CTC-FAR-EMI-RSE	System CTC-FAR-EMI-RSE	-	ETS-Lindgren/CETECOM	12 M	5	30.06.2012
448	notch filter WCDMA_FDD II	WRCT 1850.0/2170.0-5/40-10SSK	5	Wainwright Instruments GmbH	12 M	1c	30.06.2012
449	notch filter WCDMA FDD V	WRCT 824.0/894.0-5/40-8SSK	1	Wainwright	12 M	1c	30.06.2012
454	Oscilloscope	HM 205-3	9210 P 29661	Hameg	-	4	
456	DC-Power supply 0-5 A	EA 3013 S	207810	Elektro Automatik	pre-m	2	
459	DC -Power supply 0-5 A , 0-32 V	EA-PS 2032-50	910722	Elektro Automatik	pre-m	2	
460	Univ. Radio Communication Tester	CMU 200	108901	Rohde & Schwarz	12 M	-	31.03.2012
463	Universal source	HP3245A	2831A03472	Agilent	-	4	
466	Digital Multimeter	Fluke 112	89210157	Fluke USA	24 M	-	31.03.2012
467	Digital Multimeter	Fluke 112	89680306	Fluke USA	24 M	-	31.03.2012
468	Digital Multimeter	Fluke 112	90090455	Fluke USA	24 M	-	31.03.2012
477	ReRadiating GPS-System	AS-47	-	Automotive Cons. Fink	-	3	
480	power meter (Fula)	NRVS	838392/031	Rohde & Schwarz	24 M	-	31.03.2013
482	filter matrix	Filter matrix SAR 1	-	CETECOM (Brl)	-	1d	
484	pre-amplifier 2,5 - 18 GHz	AMF-5D-02501800-25-10P	1244554	Miteq	12 M	-	30.07.2012
487	System CTC NSA-Verification SAR-EMI	System EMI field (SAR) NSA	-	ETS Lindgren/CETECOM	24 M	-	30.09.2013
489	Emi Test Receiver	ESU40	1000-30	Rohde & Schwarz	12 M	-	31.03.2012
502	band reject filter	WRCG 1709/1786-1699/1796-	SN 9	Wainwright	pre-m	2	
503	band reject filter	WRCG 824/849-814/859-60/10SS	SN 5	Wainwright	pre-m	2	
512	notch filter GSM 850	WRCA 800/960-02/40-6EEK	SN 24	Wainwright	12 M	1c	30.06.2012
517	relais switch matrix	HF Relais Box Keithley System	SE 04	Keithley	pre-m	2	
523	Digital Multimeter	L4411A	MY46000154	Agilent	24 M	-	31.03.2013
529	6 dB Broadband resistive power divider	Model 1515	LH 855	Weinschel	pre-m	2	
530	10 dB Broadband resistive power divider	R 416110000	LOT 9828	-	pre-m	2	
546	Univ. Radio Communication Tester	CMU 200	106436	R&S	12 M	-	31.03.2012
547	Univ. Radio Communication Tester	CMU 200	835390/014	Rohde & Schwarz	12 M	-	31.03.2012
548	Digital-Barometer	GBP 2300	without	Greisinger GmbH	36/12 M	-	31.03.2012
549	Log.Per-Antenna	HL025	1000060	Rohde & Schwarz	36/12 M	-	31.03.2012
552	high pass filter 2,8-18GHz	WHKX 2.8/18G-10SS	4	Wainwright	12 M	1c	30.07.2012
558	System CTC FAR S-VSWR	System CTC FAR S-VSWR	-	CTC	24 M	-	31.07.2013
574	Biconilog Hybrid Antenna	BTA-L	980026L	Frankonia	36/12 M	-	30.03.2013
584	Spectrum Analyzer	FSU 8	100248	Rohde & Schwarz	12 M	-	31.03.2012
594	Univ. Radio Communication Tester	CMW500	101757	Rohde & Schwarz	24 M	-	31.03.2012
597	Univ. Radio Communication Tester	CMU 200	100347	Rohde & Schwarz	12 M	-	31.03.2012
598	Spectrum Analyzer	FSEM 30 (Reserve)	831259/013	Rohde & Schwarz	24 M	-	13.01.2013
600	power meter	NRVD (Reserve)	834501/018	Rohde & Schwarz	24 M	-	31.03.2013
601	medium-sensitivity diode sensor	NRV-Z5 (Reserve)	8435323/003	Rohde & Schwarz	24 M	-	12.01.2013
602	peak power sensor	NRV-Z32 (Reserve)	835080	Rohde & Schwarz	24 M	-	12.01.2013
608	UltraLog-Antenna	HL 562	830547/009	Rohde & Schwarz	36/12 M	-	31.03.2014
611	DC power supply	E3632A	KR 75305854	Agilent	pre-m	2	
612	DC power supply	E3632A	MY 40001321	Agilent	pre-m	2	
613	Attenuator	R416120000 20dB 10W	Lot. 9828	Radiall	pre-m	2	

6.1.3. Legend

Note / remarks		Calibrated during system calibration:
	1a	System CTC-SAR-EMS (Ref.-No. 442)
	1b	System-CTC-EMS-Conducted (Ref.-No. 335)
	1c	System CTC-FAR-EMI-RSE (Ref.-No. 443)
	1d	System CTC-SAR-EMI (Ref.-No. 441)
	1e	System CTC-OATS (EMI radiated) (Ref.-No. 337)
	1 f	System CTC-CTIA-OTA (Ref.-No. 420)
	1 g	System CTC-FAR-EMS (Ref.-No. 444)
	2	Calibration or equipment check immediately before measurement
	3	Regulatory maintained equipment for functional check or support purpose
	4	Ancillary equipment without calibration e.g. mechanical equipment or monitoring equipment
	5	Test System

Interval of calibration	12 M	12 month
-------------------------	------	----------

	24 M	24 month
	36 M	36 month
	24/12 M	Calibration every 24 months, between this every 12 months internal validation
	36/12 M	Calibration every 36 months, between this every 12 months internal validation
	Pre-m	Check before starting the measurement
	-	Without calibration

