

411-1333-204

Reunion

BTR 38 GHz

Sub-Band 38-02P

Outdoor Microwave Transceiver

Installation Guide

Release 1.2 March 1999



NORTEL
NETWORKS™

Reunion

BTR 38 GHz

Outdoor Microwave Transceiver Installation Guide

Document number: 411-1333- 204.01.02

Product release: Release 1.2

Document version: Preliminary

Date: March 1999

© 1999 Northern Telecom

Northern Telecom Ltd., all rights reserved

Printed in Canada

NORTHERN TELECOM CONFIDENTIAL: The information contained in this document is the property of Northern Telecom. Except as specifically authorized in writing by Northern Telecom, the holder of this document shall keep the information contained herein confidential and shall protect same in whole or in part from disclosure and dissemination to third parties and use same for evaluation, operation, and maintenance purposes only.

Information is subject to change without notice.

Publication history

December 1998

- Draft release of the document
- Information subject to change without notice

March 1999

- Preliminary release of the document
- Information subject to change without notice

About this guide

Purpose

This guide provides the information required to install and operate the BTR 38 GHz outdoor microwave transceiver.

The BTR 38 GHz is a key microwave component in the Nortel Reunion base station providing transmission facility for two-way digital wireless voice, data and video communications.

The BTR 38 GHz is one of the RF (Radio Frequency) products that constitute a Nortel Reunion product line. The associated products include the following types of cell site equipment:

- broadband transmitters
- broadband receivers
- broadband repeaters
- broadband transceivers

Audience

The audience for this document are those who install and operate the BTR 38 GHz. To take full advantage of this guide, you should have a basic understanding of microwave fundamentals and know how to use microwave test equipment.

Organization

1. This Guide is divided into eight sections:
 - *Product Overview* describes the BTR's components and theory of operation.
 - *Pre-Installation* describes the basics of handling the equipment upon arrival.
 - *Reunion Safety Standards* provide a quick review of general safety guidelines.
 - *Installing the BTR 38 Ghz* explains how to physically install the transceiver.
 - *BTR 38 GHz Maintenance* describes basic maintenance procedures to ensure that the transceiver is operating correctly.
 - *BTR 3800 Diagnostic Reference Chart* provides a quick troubleshooting guide.
 - *Grounding and Surge Protection* explains basic grounding and lightning protections requirements and methods for the Reunion equipment.
 - *List of terms* provides a quick reference to terms and acronyms found in the guide.

Documentation Suite

This Reunion Release has a suite of fifteen documents:

Reunion System Overview, 411- 1343 - 010

Reunion Network Node Equipment Installation Guide, 411- 1313 - 200

Reunion NIU 6054 Network Interface Unit Installation Guide,
Release 1.2, 411- 1323 - 201

Reunion NIU 6154 Network Interface Unit Installation Guide,
Release 1.2, 411- 1323 - 202

Reunion NIU 5008 Network Interface Unit Installation Guide,
Release 1.2, 411- 1323 - 203

Reunion BTR 28 GHz Outdoor Microwave Transceiver Installation Guide,
Release 1.2, 411- 1333 - 202

Reunion CTR 28 GHz Outdoor Microwave Transceiver Installation Guide,
Release 1.2, 411- 1333 - 203

Reunion BTR 38 GHz Outdoor Microwave Transceiver Installation Guide,
Release 1.2, 411- 1333 - 204

Reunion CTR 38 GHz Outdoor Microwave Transceiver Installation Guide,
Release 1.2, 411- 1333 - 205

Reunion Redundancy Switching Matrix Installation Guide, Release 1.2,
411- 1313 - 201

Reunion Procedures Reference Manual, 411-1343-400

DSS for the NNE User Guide, 411-1343-501

Reunion DSS 1000 for the NIU 6054 User Guide, 411-1343-502

Reunion DSS 1000 for the NIU 6154 User Guide, 411-1343-503

Reunion DSS 1000 for the NIU 5008 User Guide, 411-1343-504

Customer Support

In addition, Nortel Networks Broadband Wireless Access (BWA) provides 24-hour customer service and technical support to ensure your service operation is trouble-free. If you have questions or need technical support, contact Nortel Networks Broadband Wireless Access at the following telephone numbers:

- In the USA and Canada, call 972-BWA-ETAS/972-292-3827
- Fax (204) 631-2475

Write Nortel Networks at:

- Nortel Networks
Broadband Wireless Access
14 Fultz Blvd.
Winnipeg, Manitoba R3Y 1V3
Canada

Contents

Publication history	v
About this guide	vii
Purpose	vii
Audience	vii
Organization	viii
Documentation Suite	viii
Customer Support	ix
Contents	xi
BTR 38 GHz Release 1.2	1-1
Product Overview	1-1
How the BTR 38 GHz Works	1-2
BTR 38 GHz Specification	1-4
BTR 38 GHz Component Descriptions	1-6
Diplexer / Power Supply	1-6
Mixer	1-6
Dielectric Resonance Oscillator (DRO)	1-6
Isolator	1-6
Bandpass Filter	1-6
Low Noise Amplifier	1-7
IF Amplifier	1-7
Power Amplifier	1-7
Remote Monitor	1-7
Antenna	1-7
Pre-Installation	1-8
Prevention of Access	1-8
Unpacking Shipment	1-8
Reunion Safety Standards	1-9
Safety Disclaimer	1-9
General Safety	1-9
Electrical Safety	1-9
Installing the BTR 38 GHz	1-10
Attaching the Antenna	1-10
Installing the Tower Equipment	1-11
Dual Mount Bracket	1-12
Installing the Dual Mount Bracket	1-13
Installing Indoor Equipment	1-18
BTR 38 GHz Maintenance	1-28

Mechanical Checks 1-28
BTR 38 GHz Diagnostic Reference Chart 1-29

Grounding and Surge Protection **2-1**

- Grounding/Lightning Protection 2-1
 - Scope 2-1
 - Grounding Methods/Indoor Equipment 2-1
 - Wire Gauge Guidelines 2-2
 - Outdoor Equipment: the need for surge (lightning) protection 2-3
 - Ground connections to outdoor equipment 2-7
 - Regulatory Considerations 2-10
-

List of terms **3-1**

BTR 38 GHz Release 1.2

Product Overview

The BTR 38 GHz outdoor transceiver is a state-of-the-art broadband microwave transceiver designed to operate in the 39.45 to 39.65 GHz frequency band downstream and the 38.75 to 38.95 GHz frequency band upstream. It is a combined broadband transmitter and receiver deployed in Reunion's point-to-multipoint system. It is compatible with Reunion's Release 1.2 equipment.

The BTR 38 GHz transceiver is mounted on a pole or a building. It features a small size and low noise characteristics. The combination of digital modulation and low-loss mounting results in an efficient and low-cost installation. It has a high-stability reference oscillator.

The BTR 38 GHz features the following attributes:

- light-weight and compact packaging designed for mounting outdoors
- solid-state upconverter and downconverter designs
- high frequency stability over a wide temperature range
- ± 48 VDC input for use around the world

The transceiver comprises the following components:

- diplexer
- power supply
- mixers
- local oscillator
- isolators
- bandpass filters
- low noise amplifier (LNA)
- power amplifier
- antenna
- remote monitor unit
- IF amplifier

1. The BTR transceiver's input coaxial cable carries the IF signals and the power supply to the diplexer. The diplexer distributes the power to the power supply unit and interfaces with the mixer for the IF signals.
2. The 450-650 MHz transmit IF signals enter the mixer which upconverts the signals to the 39.45 to 39.65 GHz band for the transmit path. The received RF band is downconverted to a receive signal in the 50-250 MHz range.
3. The local oscillator (LO) provides local oscillator signal to the mixer. The LO uses a phase-locked dielectric resonance oscillator (DRO) with an oven controlled crystal oscillator (OCXO).
4. The bandpass filters remove the undesired sideband signals, in both the transmit and receive paths.
5. The upconverted signal is fed into the power amplifier which provides the required gain to the microwave signals. The power amplifier output is connected to the antenna through the antenna mounting flange.
6. The received RF simultaneously passes through the antenna mounting flange, where the pass band is filtered and amplified by the Low Noise Amplifier (LNA). The signal is fed into the mixer path.
7. The downconverted signal is fed into the IF amplifier which provides the required gain to the IF signals. The IF amplifier's output is connected to the IF (RX) output port.
8. The remote monitor unit is monitoring the BTR 38 GHz working status, (temperature, RF output power, power supply voltage and local oscillator status).

There are five connectors on the outside of the transceiver case:

- The IF (TX) power supply input uses a Type N female jack
- The IF (RX) output uses a Type N female jack
- Telemetry connector uses a 6 pin military style connector
- Test Port (2) use female SMA jack

BTR 38 GHz Specification

Table 1: BTR 38 GHz Technical Specifications

TX	IF Input	RF Output
Frequency Range	450-650 MHz	39.450-39.650 GHz
Output Level (P1 dB)		>+27 dBm, -40° to +30° C >+26.7 dBm, +30° to +50° C > +26.2 dBm, +50° to +55° C
Output Level (IP3)		35 dBm, -40° to +30° C 34.7 dBm, +30° to +50° C 34.2 dBm, +50° to +55° C
Input Impedance	50 Ohms	
Input/Output Connector	N-Type Female	WR-28
Input/Output VSWR	1.8:1, maximum	1:6:1, maximum
Gain (not including antenna)		35±5 dBm, minimum
Gain vs. Temperature		±2.0 dB, (-40° to +55° C)
Gain Flatness		±1.5 dB over 200 MHz BW
Out-band Spurious Emission		<-30 dBm
Frequency Stability		±2 ppm, max, (-40° to +55° C)
RX	RF Input	IF Output
Frequency Range	38.75-38.95 GHz	50-250 MHz
Nominal Input Level	- 50 dBm	
Input/Output Connector	WR-28 Cover Flange	N-Type Female
Input P1 dB	-26 dBm	
Output Impedance		50 Ohms
Input/Output VSWR	1.6:1, maximum	1.8:1, maximum
Gain (not including antenna)		39±5 dB, minimum
Gain Flatness		±1.5 dB over bandwidth
Frequency Stability		<±2 ppm, (-40° to +55° C)
Noise Figure SSB		< 7.5 dB, -40° to +30° C < 7.8 dB, +30° to +50° C < 8.3 dB, +50° to +55° C
Test Port		- 30 dBc, SMA (F)

Antenna	BTR
Frequency	38.6-40 GHz
Gain	15 dBi, 90° Horn
Input/output microwave connector for the antenna	WR-28
Mounted on transceiver housing	WR-28 flange
Size (Height x Weight x Depth)	6" x 3" x 12"
TX / RX wave polarity	linear, single pole
Sectorized Angle Available	15°, 30°, 45°, 60° and 90°
Power Supply	BTR
Input Voltage	±48 VDC
Input Current	<2 Amp
Input Power	100 Watts, maximum
Environmental	BTR
Humidity	100% condensing
Altitude	10,000 feet
Operating Temperature	-40° to +55°C
Storage Temperature Range	-60° to +75°C
Mechanical	BTR
Size (Height x Width x Depth)	19.2" x 10.3" x 6.7" (49 x 26 x 17 cm)
Weight without brackets	35 lbs. (16KG)

Note: Use the following formula to calculate the converted frequency:

$$\text{TX: } f_{\text{RF OUT}} (\text{GHz}) = 39.0 + f_{\text{IF IN}} (\text{GHz})$$

$$\text{RX: } f_{\text{IF OUT}} (\text{GHz}) = 39.0 - f_{\text{RF IN}} (\text{GHz})$$

BTR 38 GHz Component Descriptions

Diplexer / Power Supply

The diplexer separates the IF input signals and the DC power supply. The isolation between the IF path and the power supply path is more than 35 dB. There is also a transient voltage protector on the board to protect the transceiver from possible lightning damage.

The 48 VDC power from the diplexer is first regulated to 12 VDC, and then sent to all the modules.

Mixer

The BTR 38 GHz uses a third harmonic mixer. The mixer uses a 13.0 GHz local oscillator (LO) signal to convert the IF input signals to the 39.450-39.650 GHz microwave frequency band. The same LO is used to downconvert the incoming microwave signals to the receive IF frequency band.

Dielectric Resonance Oscillator (DRO)

The Dielectric Resonance Oscillator is equipped with a OCXO reference oscillator. When the DRO is phase-locked, it provides a 13.0 GHz microwave frequency with the same frequency stability as the reference crystal.

When the DRO is phase-locked, the phase-locked voltage at the test port on the DRO can vary from 3 VDC to 10 VDC depending on the chassis temperature and the input reference frequency. The voltage at the alarm test port is approximately 5 VDC.

When the DRO is unlocked, the phase-locked voltage becomes an oscillating ramp wave. The voltage at the alarm test port goes down to 0 VDC.

Isolator

Three isolators provide adequate return loss in the BTR 38 GHz. Each isolator's maximum forward insertion loss is 0.5 dB, and its return loss is greater than 18 dB.

Bandpass Filter

The bandpass filter removes the undesired sideband elements and LO leakage, and passes the required sideband signals.

Low Noise Amplifier

The low noise amplifier (LNA) provides gain in the receive path and amplifies the received microwave signals to the mixer. The gain and noise figure of the LNA are chosen to maximize the overall dynamic range and noise performance of the BTR 38 GHz receiver section.

IF Amplifier

The IF amplifier provides gain in the downconverted received signals to the required level. It uses a VHF amplifier with 50 Ohms input and output impedance.

Power Amplifier

The power amplifier provides gain in the transmit path. It boosts the signals in the 39.45-39.65 GHz frequency range to the required level. The amplifier is a solid state amplifier that has high linearity within a high output power range.

Remote Monitor

The remote monitor unit provides an interface for remotely monitoring the BTR 38 GHz. The unit communicates with the RSM 9016 by way of a shielded twisted pair wire cable. An operator can remotely measure and monitor RF output power (0 to 27 dBm), DRO phase voltage (0 to 10 volts), DRO phase lock alarm (0, 1), internal temperature (-40 to +80°C) and power supply voltage (12 volts). Refer the *Reunion Redundancy Switching Matrix Installation Guide*, 411-1313-201, the *Reunion DSS 1000 (Digital System Supervisor) User Manual*, 411-1343-500, and the *Reunion DSS 1000 for the NIU 6054 User Guide*, 411-1343-502.

Antenna

The BTR 38 GHz uses a sector antenna for transmitting and receiving RF signals. Physically, an antenna unit, which interfaces to the radio, contains two sector antennas (one for transmit and one for receive). The antenna unit is either horizontally or vertically polarized. One antenna port is connected to the transmit side and the other one is connected to the receiver RF input.

The antenna is shipped either vertical-vertical (Tx-Rx) or horizontal-horizontal.

Note: Lightning arrestors are not supplied with the BTR transceiver.

Pre-Installation

Prevention of Access

Allow only authorized personnel to access the equipment. Install the equipment in a restricted-access location or similar environment. Failure to prevent unauthorized user access invalidates the equipment warranty.

Unpacking Shipment

Use the following steps to unpack and inspect the shipment of Nortel Broadband Wireless Access equipment:

1. Copy adequate inventory forms
2. Check each package against the order form and packing slip to ensure that all components are received
3. Check each package for signs of damage
4. Open the package and closely inspect all components for obvious signs of damage
5. Know exactly where you are going to place the equipment, before removing them from the package
6. Carefully remove the equipment from the packaging
7. Save packing material for future use
8. Be aware of electrostatic discharge devices (ESD) requirements when handling BWA equipment



Note: For more information, refer to the Electronic Industries Association (EIA) standard, *Requirements for Handling Electrostatic-Discharge-Sensitive Devices (ESDS)*, EIA-625, as well as local and national standards.

Reunion Safety Standards

Safety and safety considerations are important while using Nortel Broadband Wireless Access equipment.

Safety Disclaimer

The safety standards discussed in this guide cannot address all safety problems associated with their use or all applicable regulatory requirements. The customers are responsible for establishing appropriate safety and health practices and for determining the applicability of regulatory limitations before their use.

General Safety

Ensure that installation personnel are trained on CPR (Cardio Pulmonary Resuscitation), as well as on local, regional and national safety standards.

When working on Nortel Broadband Wireless Access equipment, follow these guidelines:

- Keep your work site clean and free of clutter.
- Wear close fitting clothing.
- Remove jewelry such as rings, bracelets, or watches.
- Where it is possible to dislodge small pieces, wear eye protection.
- Place equipment or cabinets on level surfaces.
- Wear a safety belt when climbing a tower and installing equipment on a tower.
- Work in pairs so that you have someone to help in case of an emergency.

Electrical Safety

Locate the main power shut-off switch controlling the equipment you are working on. This is important in the event of an accident, so you can quickly cut the power.

Disconnect all power when working on power supplies.

In an emergency (electrocution):

- shut the power off
- have someone call for emergency medical assistance
- start CPR



Warning

Do not move in front of the antenna, nor look directly into the face of the antenna when the BTR 38 GHz is running.

Installing the BTR 38 GHz

Installation is performed in three separate operations:

- attaching the antenna
- installing the tower equipment
- installing the indoor equipment

Attaching the Antenna

Attach the antenna to the BTR as follows:

Ensure that you attach the antenna to the BTR radio at the base station prior to mounting the BTR 38 GHz to the pole.

1. Align the antenna with the two dowel pins that act as an index.
2. Place the flat washer against the antenna flange, followed by the lock washer and then the screw.
3. Use an Allen wrench # 8 to hard tighten the socket head cap screw to a maximum of 28 inch-pounds torque.
4. Complete steps 4 and 5 for all eight socket head cap screws.
5. Ensure that the screw is inserted at the top of the antenna to prevent water entering the antenna. However, loosen it halfway. The bottom screw is removed to allow condensation to drain from the antenna.

See Figures 1- 10 and 1- 11.

Note: This is a redundant radio system and two BTRs need to be mounted close to each other. One radio is active and the other one is a stand-by. When the BTRs are mounted side by side, ensure that the spacing between the antennas is a minimum 6 inches (for 15, 30, 45, 60, and 90 sectors). When the BTRs are mounted one on top of the other, ensure that the spacing between the antennas is a minimum 1 inch (this is applicable to a 9 elevation beam width).

Installing the Tower Equipment

Install the BTR 38 GHz microwave transceiver as follows:

The radio mounting saddle has no paint on the inside surface in order to provide a grounding.

1. Ensure that the radio mounting surface on the pole is free of paint to provide a grounding.
2. Mount the BTR 38 GHz to a stable pole using the supplied mounting brackets. The mounting brackets accommodate poles with outside diameters from 2.5" to 4.5". See Figures 1-11, 1-12, 1-15, 1-16, and 1-21.
3. There are four 1/2" 13 UNC threaded rods, along with four hex head nuts and flat and lock washers. Thread the rod into the saddle bracket, then tighten with the nut. The flat washer is against the exterior of the bracket, followed by the lock washer and then the nut.
4. Ensure connectors are facing down.
5. Install the BTR 38 GHz so that the fin array (heat sink) is positioned away from external barriers to allow heat dissipation through natural convection and radiation. See Figures 1-11, 1-17, 1-18, and 1-21.

The BTR 38 GHz requires 48 VDC power supply unit.

6. Connect the TX/power coaxial cable from the RPE 9000's TX female N-Type connector to the BTR's N-type IF and PS IN port.
7. Connect the RF coaxial cable from the RPE 9000's RX female N-Type connector to the BTR's N-type IF OUT port.
8. Connect the telemetry cable from the BTR 38 GHz to the RPE 9000's telemetry connector. There is a 300 baud modem connection between the BTR 38 GHz, the RPE 9000 and the RSM 9016. See Figures 1-11 and 1-17.
9. Seal all connections using Coax-Seal®, cold shrink or hot shrink tubing.
10. Ground all RF cables at the recommended spacing intervals. (Refer to tower and cable manufacturers' specifications).
11. Ensure that all feed lines are securely attached to the support structure. Plan for drip (service) loops on all cables.
12. The BTR 38 GHz has a vertical range of motion of +7° over and -23° under the horizon, as shown in Figures 1-13 and 1-14.
13. Refer to *Outline and Installation Drawing # PO 883482* and the *Reunion Redundancy Switching Matrix Installation Guide*, 411-1313-201.



Caution

Do not turn on the power supply until the installation is complete.

After you install the equipment, check the cable connections.

Dual Mount Bracket

The dual mount bracket provides a single mounting facility for both the primary and the redundant microwave transceivers, and the RPE 9000. In turn, it is mounted on the single pole facility supplied by the network operator.

The installer can adjust the elevation of either the individual transceiver or both transceivers in unison. The installer can adjust the lateral angle of the entire radio assembly. A stabilizing collar facilitates the operation of adjusting the lateral angle of the radio as well as secures the unit to the pole. The stabilizing collar consists of a saddle bracket and clamp that are bolted onto the mounting pole. The dual mount bracket sits on the stabilizing collar.

Figure 1-2
Installed Dual Mount Bracket with Transceivers

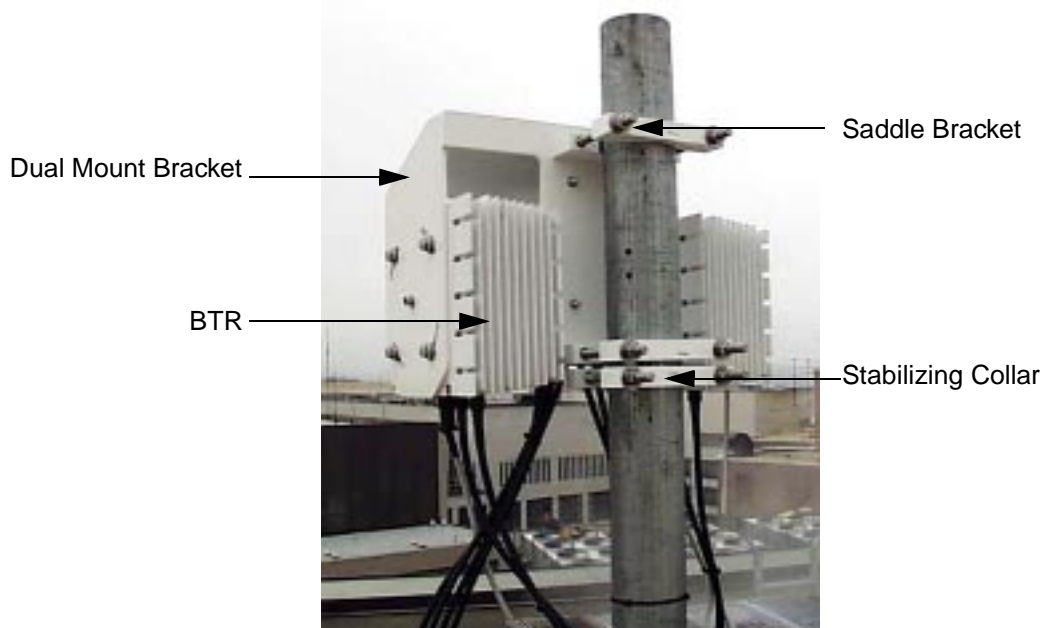

Installing the Dual Mount Bracket

Installation involves five separate operations:

- installing the stabilizing collar
- mounting the RPE to the dual mount bracket
- mounting the dual mount bracket to the mounting pole
- mounting radios to the bracket
- mounting the adjustment arm to the dual mount bracket

Installing the Stabilizing Collar

Bolt the saddle bracket and clamp to the mounting pole. Refer to Figure 1-2.

Mount the stabilizing collar first to provide support for the dual mount bracket.

Installing the RPE

Mount the RPE 9000 between the two transceivers. The front plate faces forward and the back plate faces backward. Refer to Figures 1-3 and 1-4.

Place the RPE flush against the inside back panel of the dual mount bracket. Align the holes.

Insert the screws into the holes and secure the RPE to the dual mount bracket.

Use four 1/4" by 1" long bolts, as well as four hex nuts, four lock washers and four flat washers.

Installing Dual Mount Bracket

Mount the dual mount bracket (base assembly A0765861) to the mounting pole using the supplied clamps and bolts.

Attach the two clamps (P0887173) onto the base assembly/dual mount bracket using four 1/2" bolts, four 1/2" lock washers and four 1/2" flat washers.

Screw two 1/2" by 6 1/4" long threaded rods into each clamp.

Position the clamps close to the mounting pole, with the rods straddling the pole.

Place the saddle supports (P0890191) on the opposite side of pole and screw the threaded rods through them. Secure them with flat and lock washers and hex nuts.

Sit dual mount bracket onto stabilizing collar for support.

Installing the Radios

Install the primary transceiver on the left exterior side of the dual mount bracket (front view). Refer to Figure 1-3.

Insert the compression lug, adjacent to the unpainted area of the bracket unit, and secure with 3/8" screw and flat and spring washers. Crimp a number 6 AWG ground wire to the lug.

Insert the top two 3/8" screws and secure with flat and spring washers.

Position the back-up transceiver on the right interior side of the bracket (front view).

Secure it the same way as the primary transceiver.

Note: The dual mount bracket with the RPE and two transceivers weighs approximately 100 lbs.

Installing the Adjustment Arm

Mount the adjustment arm/handle assembly (P0888357) to the bottom of the dual mount bracket. Refer to Figure 1-3.

Position the left side of the handle on the left interior side and the right side of the handle on the right exterior side of the dual mount bracket assembly.

Screw four 3/8" by 7/8" long bolts through the mount to each transceiver, two bolts per side. Secure with flat and spring washers.

The adjustment arm with the transceivers attached can be adjusted up and down vertically. It can be adjusted 23° down and 7° up, that is angled down or up. Refer to Figures 1-7 and 1-8.

The polarity of the transmit and receive signals at the transceivers' antennas are separated by 90°. Horizontal and vertical polarity is marked on the antennas.

Note: The bracket can accommodate a range in pole diameter between 2.5" and 4.5" (outside diameter).

Wind loading spec: maximum 45 pounds lateral force in any direction during a 100 MPH wind

Figure 1-3
Dual Mount Bracket-Front View

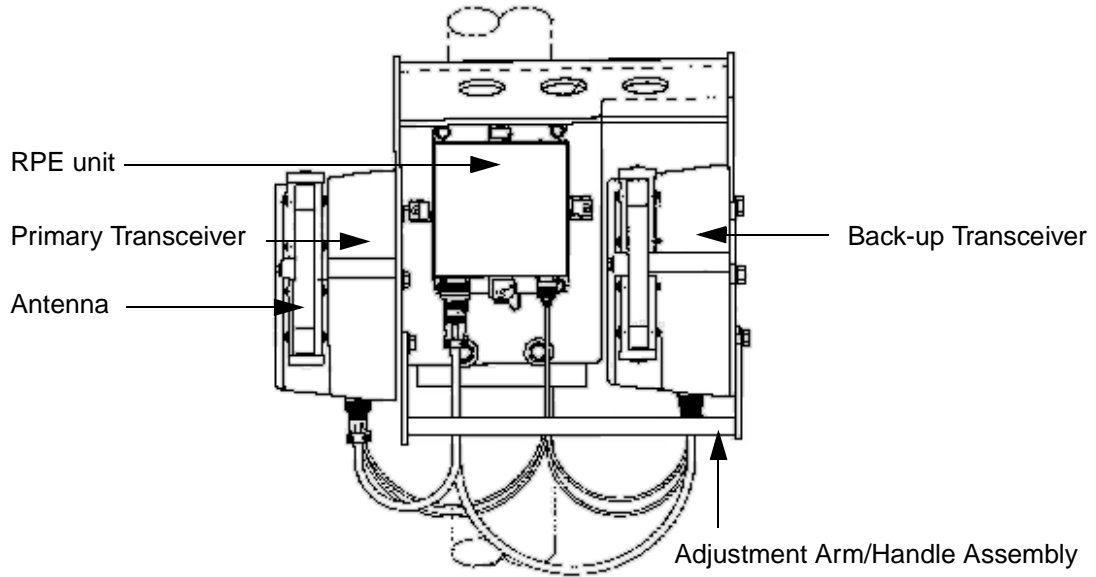

Figure 1-4
Dual Mount Bracket-Bottom View

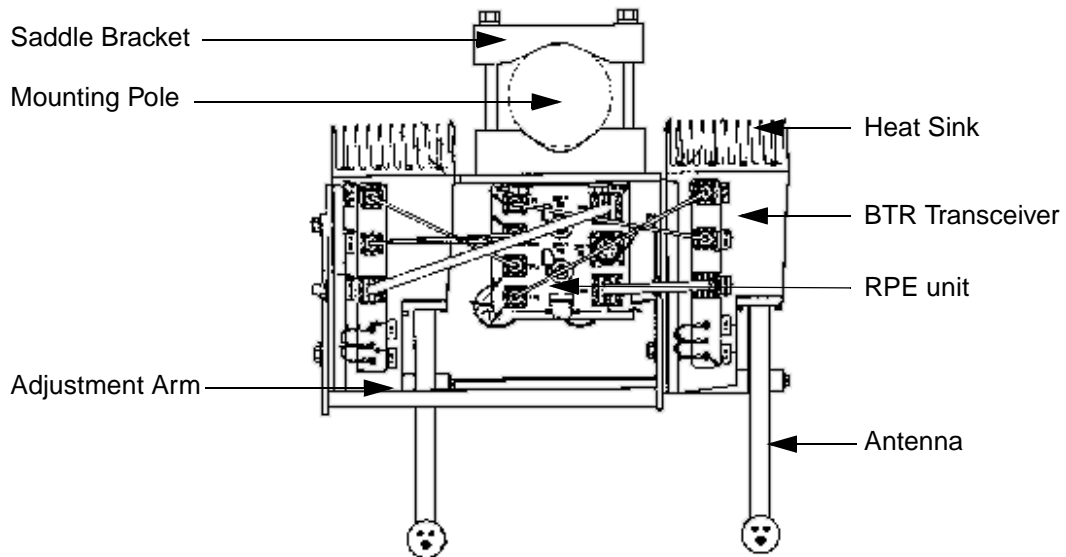

Figure 1-5
Dual Mount Bracket-Top View

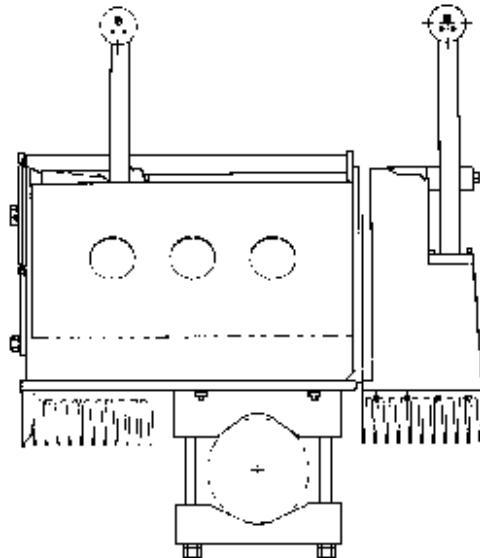

Figure 1-6
Dual Mount Bracket-Side View

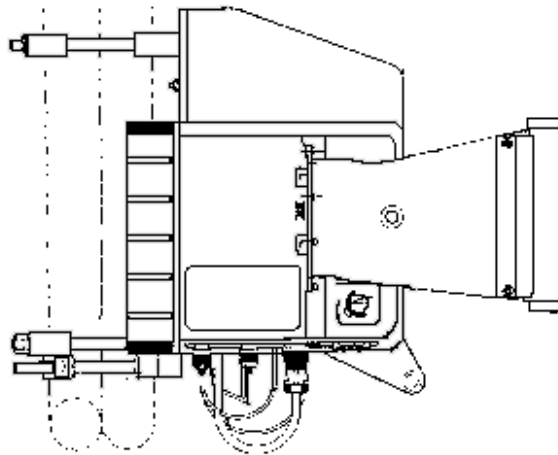

Figure 1-7
Dual Mount Bracket-Adjustment Above Horizon

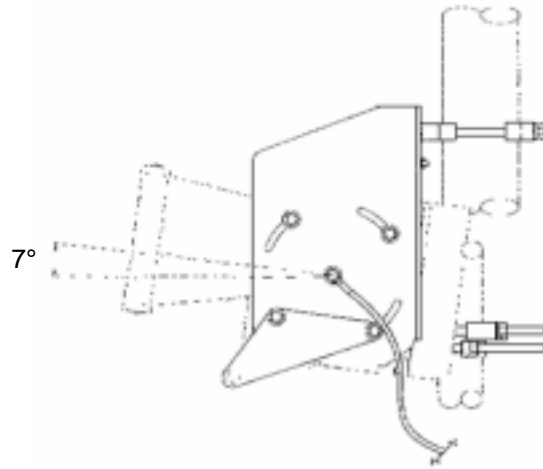
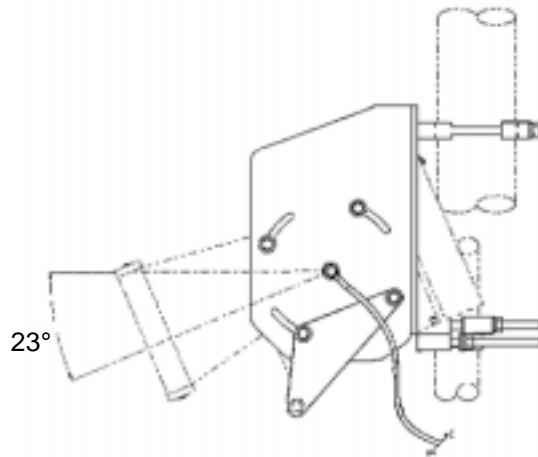

Figure 1-8
Dual Mount Bracket-Adjustment Below Horizon



Installing Indoor Equipment

Both the primary and the redundant BTR 38 GHzs are connected to and switched by the RPE 9000. The RPE 9000 is connected to both the RSM 9016 and the RSM 9116. The RSM 9016 is connected to the SMMs, while the RSM 9116 is connected to the SDMs. The RSM 9016, RSM 9116, SMMs (Signal Modulator Module) and SDMs (Signal Demodulator Module) are installed in the NNE (Network Node Equipment unit). The SMMs modulate ATM cells for wireless transport, while the SDMs interface RF to digital at the base station and demodulates the QAM signal.

Install the indoor equipment associated with the BTR 38 GHz microwave transceiver as follows:

1. Connect the telemetry cable from the RPE 9000's telemetry connector to the RSM 9016.
2. Connect the TX/PS coaxial cable from the RPE 9000 to the RSM 9016.
3. Connect the RX coaxial cable from the RPE 9000 to the RSM 9116.
4. Refer to the *Reunion Redundancy Switching Matrix Installation Guide*, 411-1313-201.
5. Refer to site specific documentation for detailed information, such as the supplied engineer's documentation.

Figure 1-9
Block Diagram showing BTR 38 GHz indoor set-up

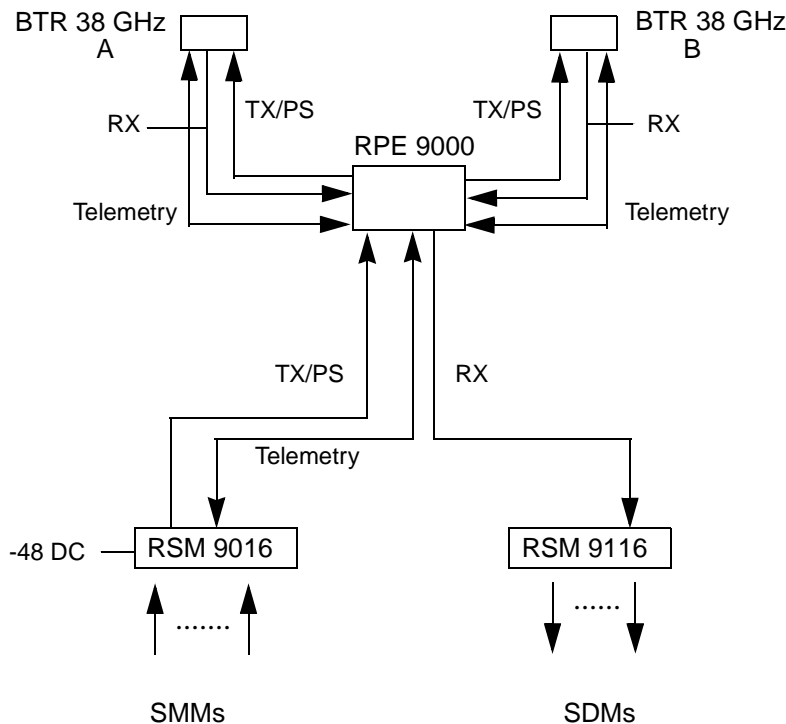

Figure 1-10
BTR 38 GHz Side View

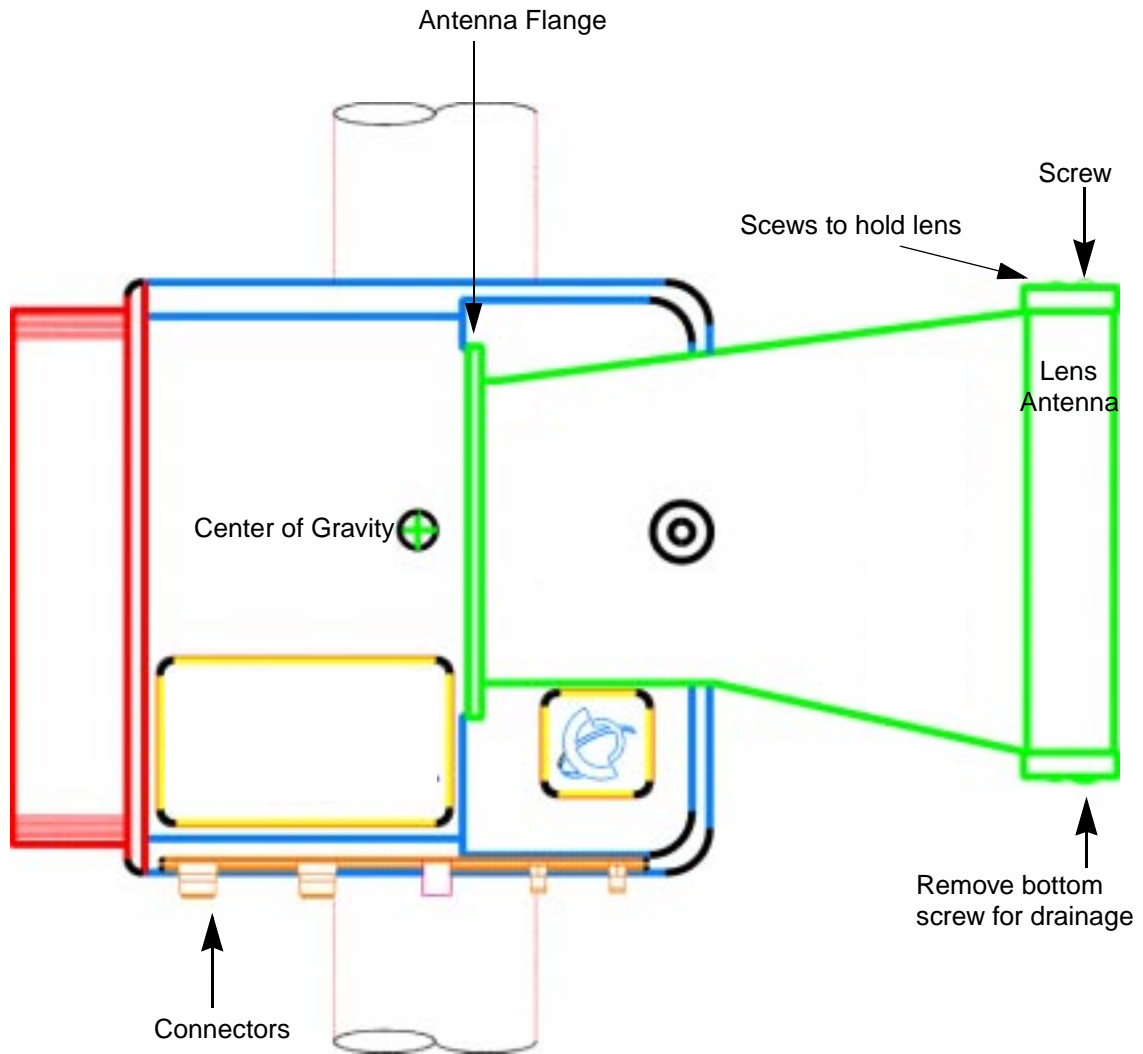

Figure 1-11
The BTR 38 GHz Bottom View

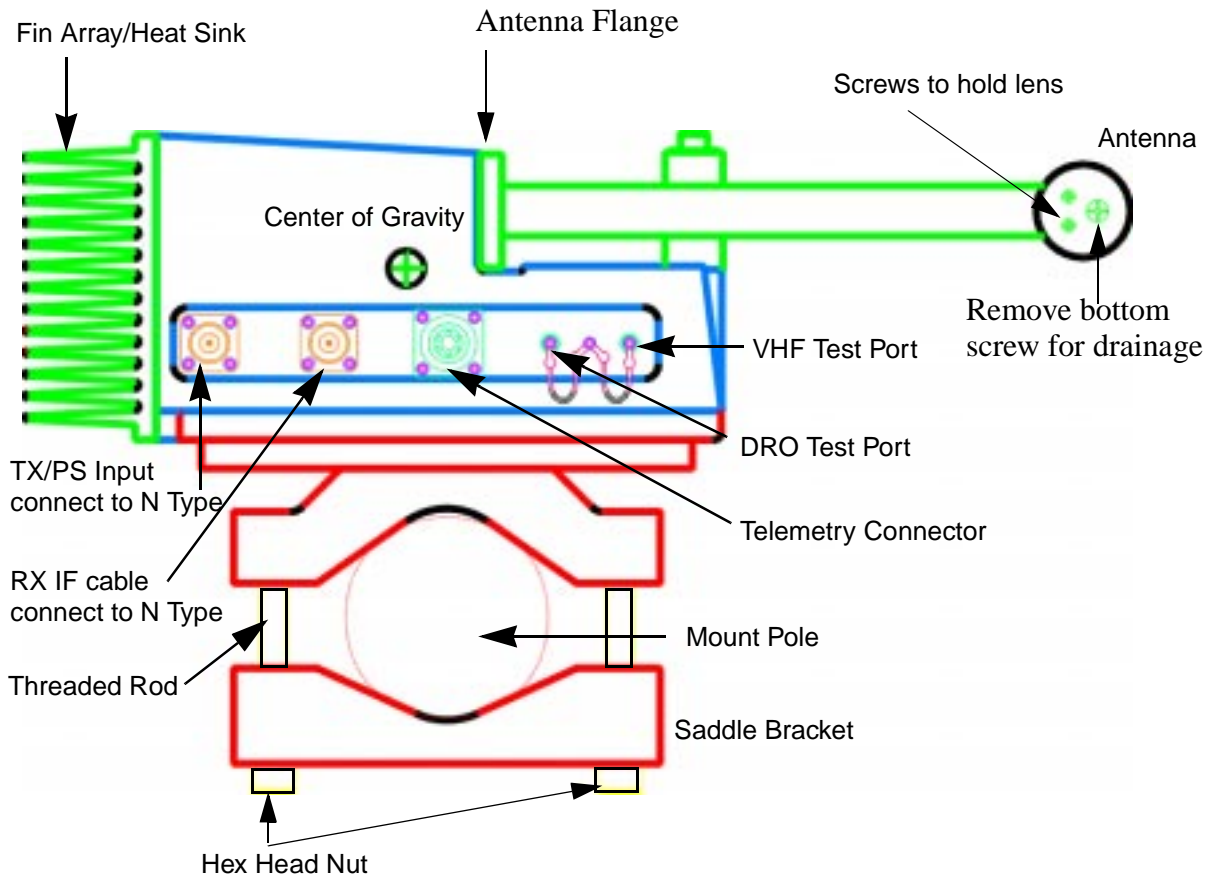

Figure 1-12
BTR 38 GHz Mounted to a Pole

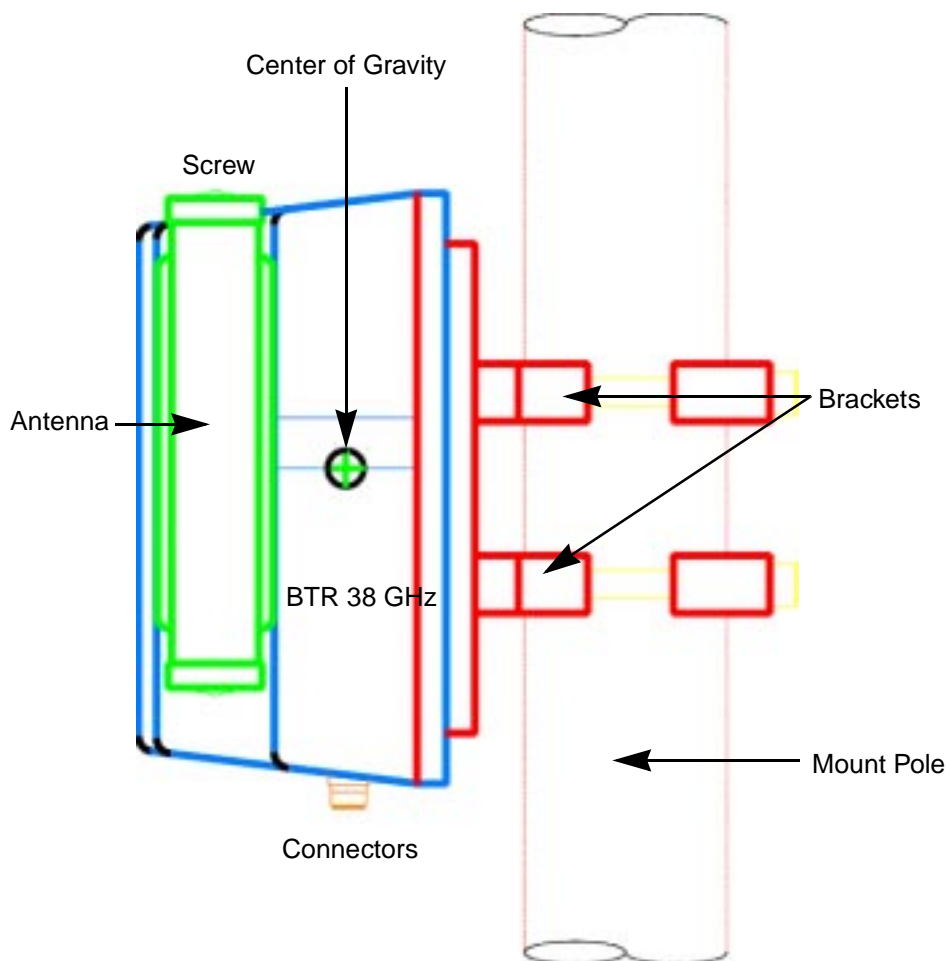

Figure 1-13
BTR 38 GHz-Adjustment Above Horizon

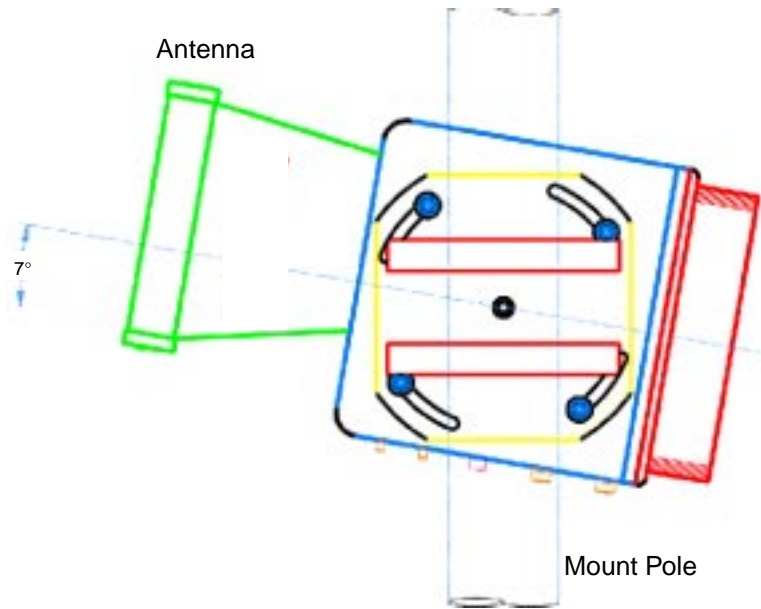

Figure 1-14
BTR 38 GHz-Adjustment Below Horizon

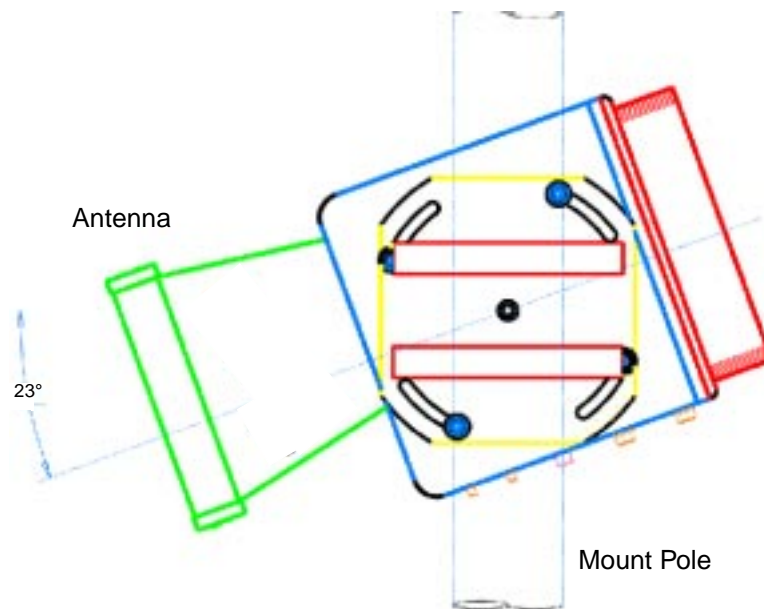
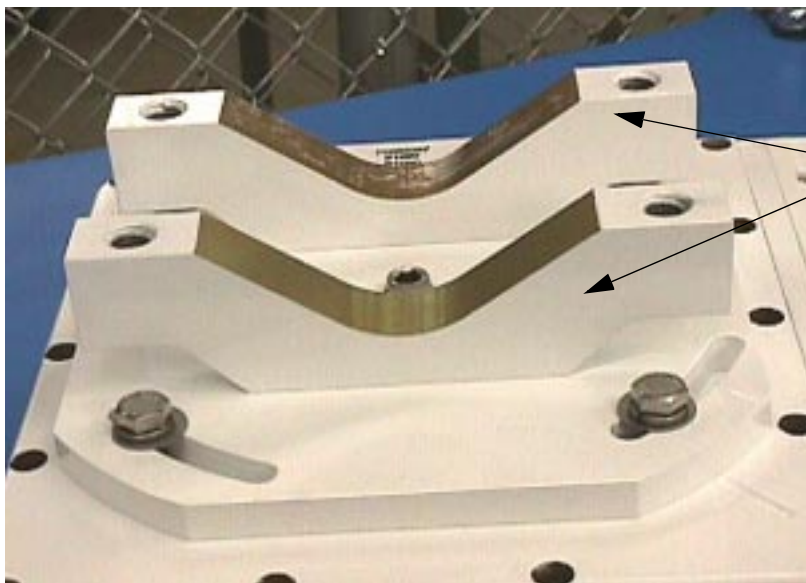

Figure 1-15
BTR 38 GHz-Bracket Components



Figure 1-16
BTR 38 GHz Brackets



Brackets
attached to
BTR 38 GHz

Figure 1-17
BTR 38 GHz Connectors -Bottom View

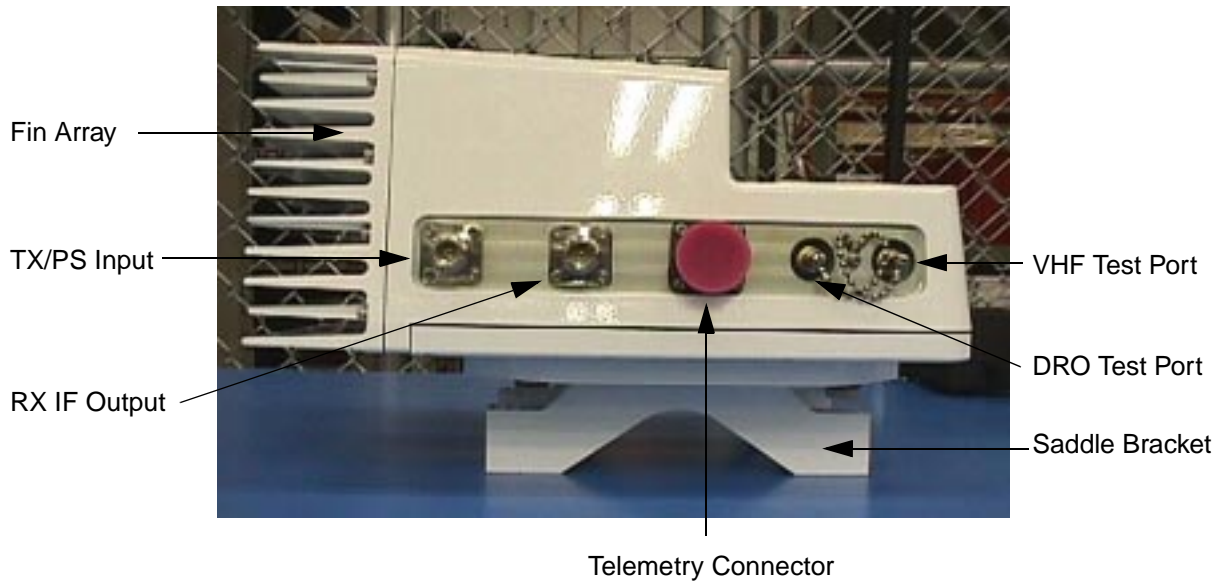

Figure 1-18
BTR 38 GHz Fin Array



Figure 1-19
BTR 38 GHz Antenna Flange

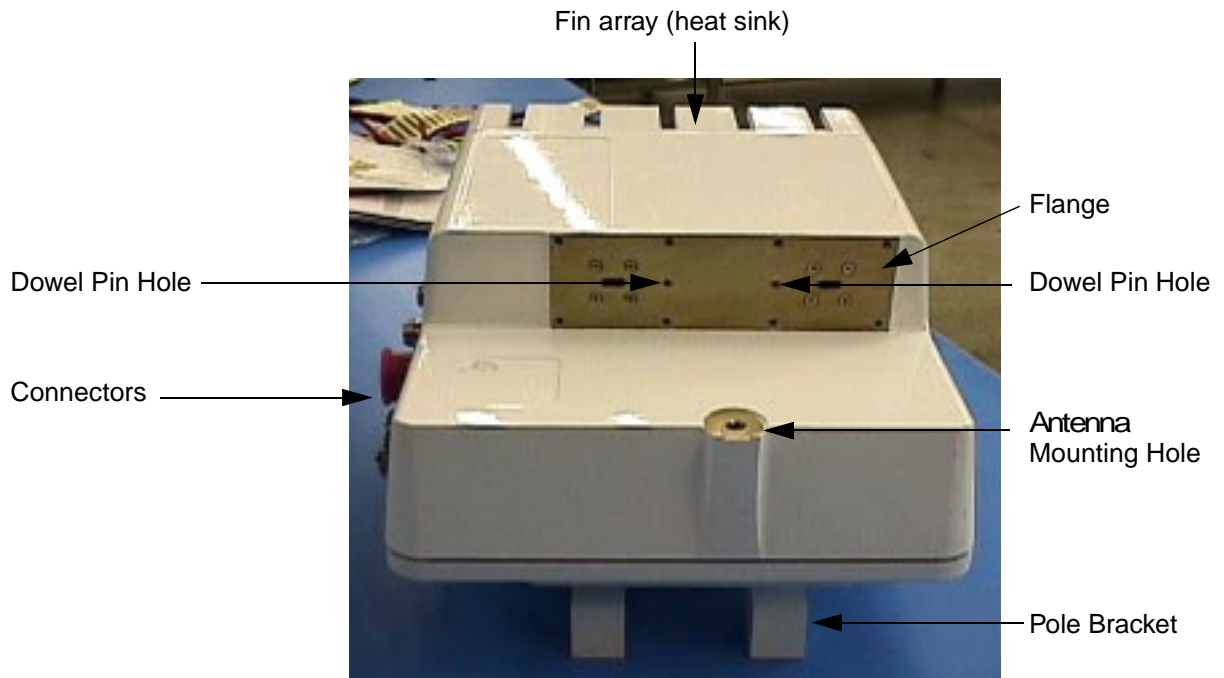

Figure 1-20
BTR 38 GHz Radio



Figure 1-21
BTR Mounted on a Pole

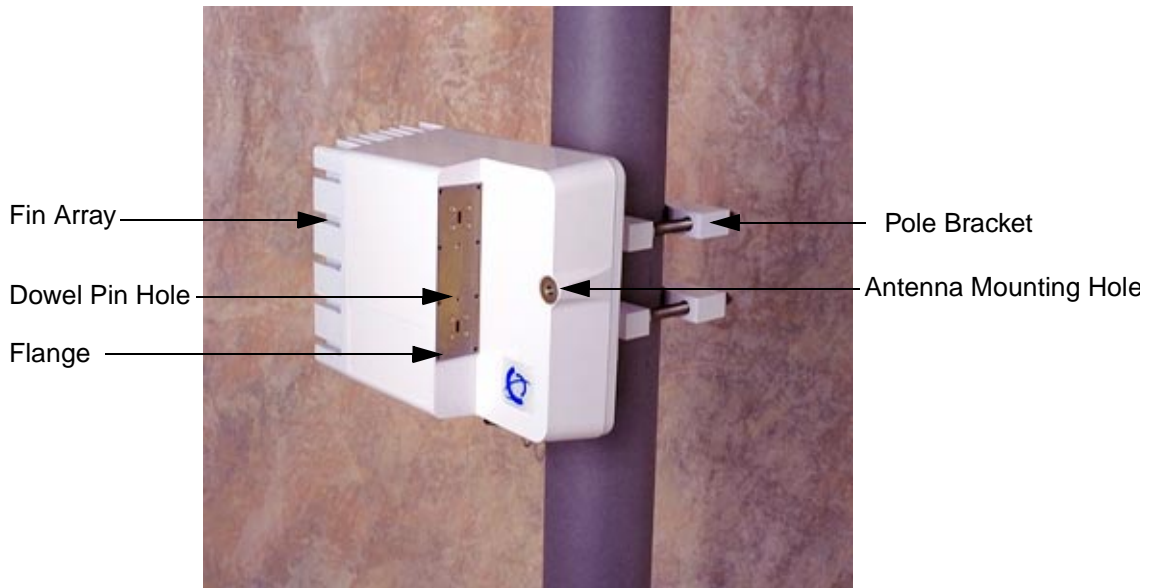

Figure 1-22
BTR Antenna

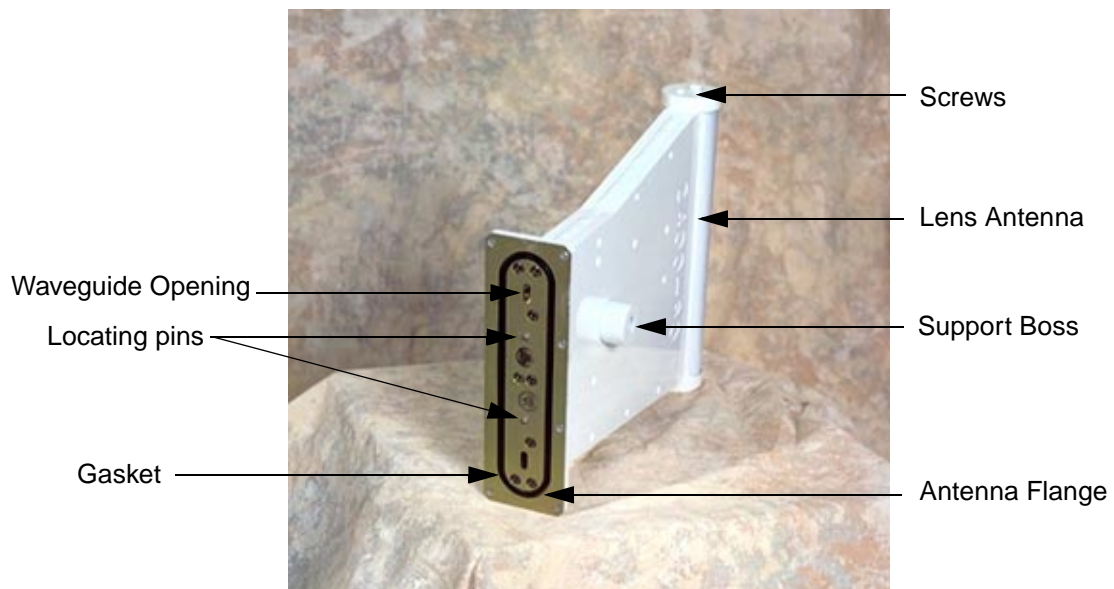
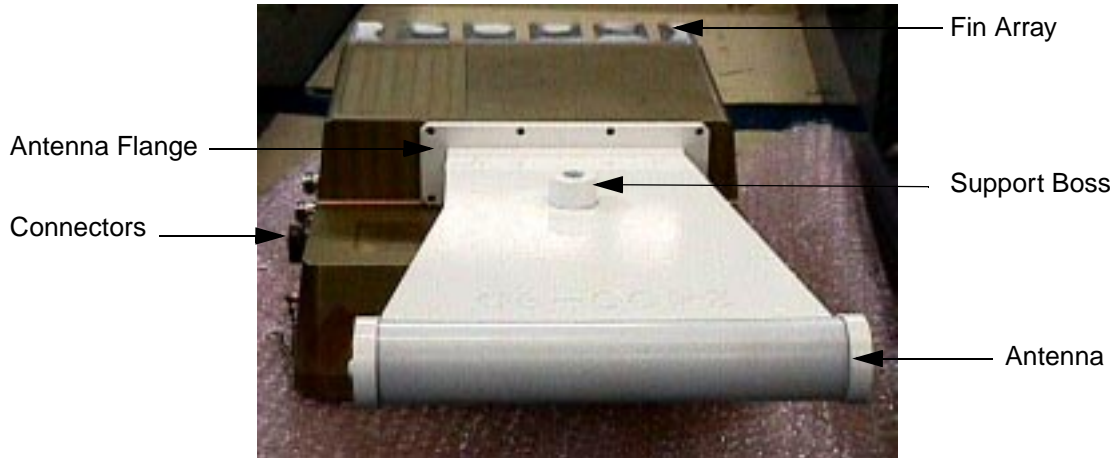

Figure 1-23
BTR prototype showing antenna



BTR 38 GHz Maintenance

Establish a regular check procedure. This quickly identifies any problem which might develop. There are no repairable internal components in the BTR 38 GHz. Therefore, the checks focus on the exterior features of the transceiver unit.

Mechanical Checks

Check the following mechanical areas to prevent problems:

1. Check the bolts and fasteners which hold the transceiver, waveguides, and antenna. Vibrations due to wind can cause bolts and fasteners to loosen. Verify that equipment is secure and properly mounted. If the bolts or fasteners are loose, tighten them carefully. Use lock and spring washers.
2. Check to ensure that all connections between the transceiver and antenna remain watertight. If water enters the waveguide or coaxial connections, it can cause attenuation of the microwave signals. If water is detected, call Nortel Networks Broadband Wireless Access.
3. Visually inspect all equipment for signs of external damage. If signs of damage are detected, call Nortel Broadband Wireless Access.

Note: If you detect an unsolvable problem during the electrical and mechanical inspections, contact Nortel Networks Broadband Wireless Access so that action can be taken to rectify the problem.

BTR 38 GHz Diagnostic Reference Chart

Symptom	Possible Cause	Check Procedure
Output power low	1. VHF input signal level low.	a. Check VHF signal level. b. Check coaxial cable. c. Check cable connectors. d. Check blockage (for example guano)
No power		a. Check main fuse power b. Check cable connections

If you detect any problem during the electrical and mechanical checks, contact Nortel Networks Broadband Wireless Access so that action can be taken to rectify the problem.



Caution

Warranty void if seal is opened. This means do not attempt to remove cover.



Caution

Warranty void if BTR is not equipped with lightning arrestor.

Grounding and Surge Protection

Grounding/Lightning Protection

Scope

This chapter presents guidelines for the grounding and electrical protection of Reunion equipment in typical buildings, assuming

1. indoor equipment is installed in an appropriate equipment room and
2. outdoor equipment is installed on rooftops using a pole mount.

Further, Nortel Networks assumes building electrical systems comply with the appropriate national and local regulations.

Grounding Methods/Indoor Equipment

Components of a communications system can be grounded together using an isolated bonding network (IBN). The IBN can be configured in several different ways:

1. Mesh
2. Mesh – IBN with bonding mat
3. Star or sparse-mesh

In turn, the IBN is bonded at a single point to the Common Bonding Network (CBN) that forms the principal bonding network in a building. Figure 2-1 shows a typical installation:

Figure 2-1
Typical Grounding configuration for Indoor Equipment

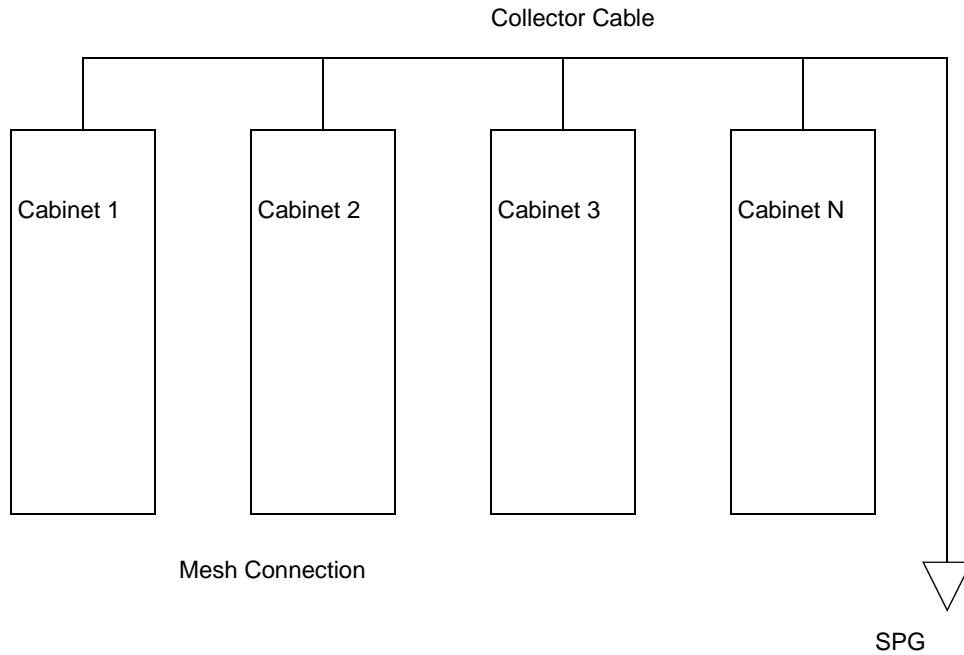

The single point ground (SPG) represents the connection of IBN to the building grounding system.

Wire Gauge Guidelines

Main bonding conductors

All main bonding conductors in the equipment room shall be No. 2 AWG or larger copper wires.

Other bonding conductors

All other bonding conductors in the room, including

- bonding individual frames/cabinets to the collector cable, supplementary conductor or BPG
- bonding conductors of other metallic objects such as cable trays and building utility equipment

are No. 6 AWG or larger insulated copper conductors.

Outdoor Equipment: the need for surge (lightning) protection

Apart from the need to provide good grounding for safety, outdoor equipment is subject to more environmental hazards than is indoor equipment. Radio communication equipment, with antennas mounted well above ground level, have conductive parts exposed to lightning.

Safety needs are met by grounding practices and protection needs are met by a combination of grounding and protective devices. Many protective devices are available:

- air terminals,
- solid state OVPs,
- filters,
- zeners,
- MoVs,
- isolators
- capacitors,
- resistors,
- QWS and more.

The application of these devices is beyond the scope of this document. The equipment designer needs to consider both the protection requirements and the geographic region where the equipment is installed.

Grounding and Lightning Protection

In general, all exposed metallic equipment must be grounded. Besides the need for lightning protection, it is desirable to conduct induced current to ground through as low a resistance as possible, along as short a path as possible.

In practice this means multiple ground connections and multiple conductors. Figure 2-2 shows a typical rooftop installation of Reunion customer premise equipment. Figure 2-3 shows a typical rooftop installation of Reunion base station transceiver (BTR).

The radio equipment should, where possible, be grounded through the ground lug using a 6AWG bonding wire to the building common bonding network. Alternatively, the equipment can be grounded through the mounting bracket. Provision must be made to prevent corrosion on the metallic contact surfaces. Similarly, the installer shall ensure that there is a good metallic connection to the building CBN.

If a common mounting plate is used for the two redundant BTRs and the radio power extractor (RPE), the installer shall insure that ground continuity to the CBN is maintained and corrosion protection is applied. The common

2-4 Grounding and Surge Protection

mounting plate should be considered as an alternative bonding to the preferred technique of separately bonding each BTR and RPE. The size of the bonding wire should be #6 AWG.

The coaxial cable shall be bonded at least at the RPE/BTR/CTR and at the building entry. For a tower higher than 30 meters (98 ft), the cable shall be bonded at 30 meter intervals. The size of the bonding conductor shall be #6 AWG or larger.

Mount the radio in an area protected from lightning strikes. If local conditions require an air terminal, install it in accordance with ANSI/NFPA 780. The air terminals are shown schematically in Figures 1-2 and 1-3. The air terminal (lightning rod) if used, is at least 1 meter (3.3 ft) above the highest object being protected and within 2 meters (6.6 ft) \pm 30 cm (1.0 ft) of the object.



Caution

Do not install Reunion equipment on lightning protection air terminals.

Figure 2-2
Rooftop Installation of Reunion Base Radio Equipment

NOTE

The outer coaxial cable conductor is bonded (grounded) at the building entrance and at the customer premise transceiver (CTR).

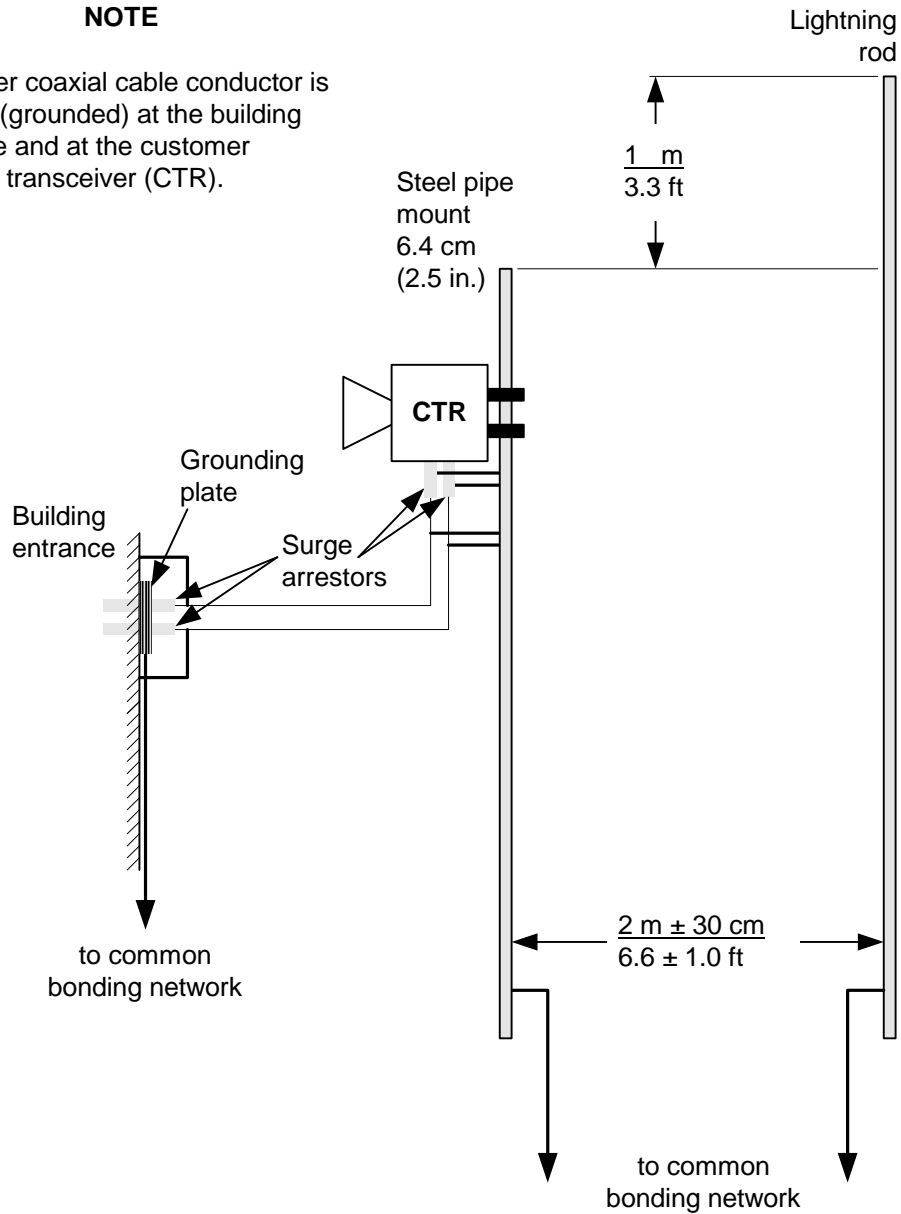
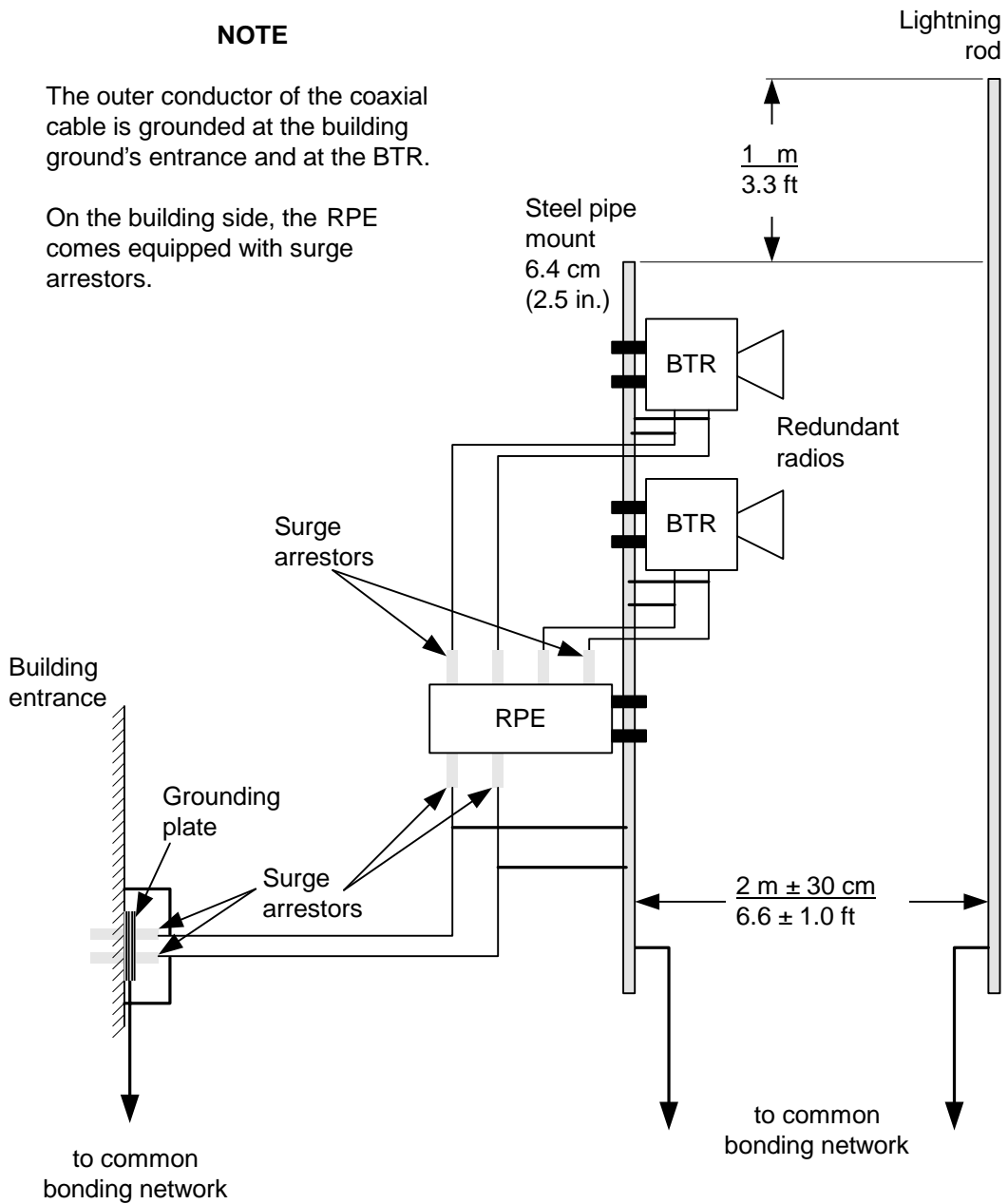

Figure 2-3
Rooftop Installation of Reunion Base Radio Equipment



Ground connections to outdoor equipment

The grounding lug is supplied with all current releases of outdoor brackets. In addition, a 6 AWG braided ground wire connected to the common bonding network is required to complete the ground connection for all microwave products.

Note: There is no grounding lug supplied with previously-released microwave products. To retrofit these installations, order one retrofit kit for each sector and use the following procedures.

Retrofit procedure for grounding the base station equipment (BTR and RPE)

You will need an NTVG15BA BTR and RPE grounding retrofit kit for every base station sector to be retrofitted, containing the following parts:

Item	Qty	Vendor part no.	Description	CPC no.
1	2	LCA6-38	6 AWG, 3/8" compression terminal (Panduit) for BTR	A0297956
2	1	LCA6-14	6 AWG, 1/4" compression terminal (Panduit) for RPE	A0315080
3	2	W-2064	1/4" Stainless steel internal tooth lock washer (Spaenaur) for RPE	TBD
4	2	W-2069	3/8" Stainless steel internal tooth lock washer (Spaenaur) for BTR	TBD

Use the following method to install the kit on the BTR, referring to Figure 2-4:

- 1 Remove the 3/8" mounting bolt, two flat washers and the mounting washer from the BTR. Discard one flat washer and the locking washer.
- 2 Crimp the 3/8 terminal (A0297956) onto the grounding wire.
- 3 Install the existing bolt, flat washer, new internal tooth washer, and the complete ground cable as shown in Figure 2-4.

Use the following method to install the kit on the RPE, referring to Figure 2-4:

- 1 Remove the 1/4" mounting bolt and split lock washer as shown in Figure 2-4.
- 2 Crimp the 1/4 terminal (A0315080) onto the grounding wire.
- 3 Install the 1/4" original mounting bolt and a stainless steel internal tooth washer.
- 4 Repeatedly tighten and loosen the fastener assembly, rotating the internal tooth lock washer, until the powder coating is scraped off and the bare metal is exposed. Repeat this procedure if required.
- 5 Discard the internal tooth washer used to remove the powder coating.
- 6 Using new stainless steel internal tooth washers, assemble the complete ground cable connection, as per Figure 2-4.

Figure 2-4
Grounding the BTR and RPE

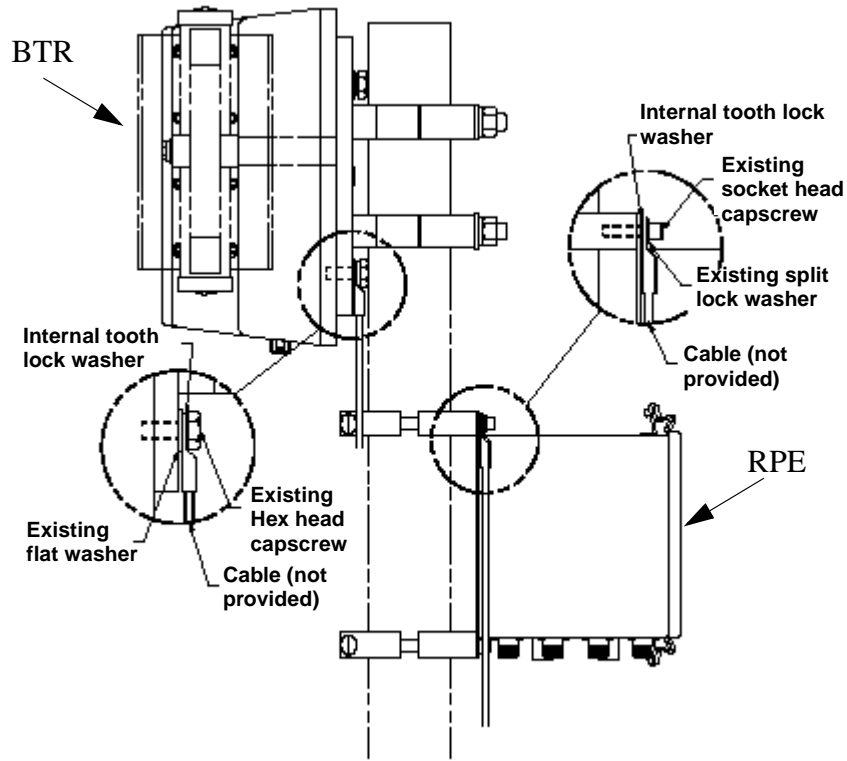

Retrofit procedure for grounding the customer premise equipment (CTR)

You will need an NTVG15CA CTR grounding retrofit kit for every CTR to be retrofitted, containing the following parts:

Item	Qty	Vendor part no.	Description	CPC no.
1	5	LCA6-38	1/4" Stainless steel internal tooth lock washer (Spaenaur)	TBD
2	1	LCA6-14	6 AWG, 1/4" compression terminal (Burndy) for CTR	A0315080
3	3		1/4" stainless steel flat washer	P0883797
4	1		1/4" x 1" Stainless steel hex head bolt	P0888501
5	2	MS35649-2254	1/4" Stainless steel nut	P0860421

Use the following method to install the kit on the CTR, referring to Figure 2-5:

- 1 Install the 1/4" stainless steel hex bolt, stainless steel flat washer and the stainless steel internal tooth washer through one of the four holes in the CTR. (Refer to Figure 2-5 for the hole location.)
- 2 Install a stainless steel internal tooth washer, stainless steel flatwasher and the 1/4" nut onto the assembly installed in Step 1.
- 3 Repeatedly tighten and loosen the fastener assembly, rotating the internal tooth lock washer, until the powder coating is scraped off and the bare metal is exposed. Repeat this procedure if required.
- 4 Discard the internal tooth washer used to remove the powder coating.
- 5 Using new stainless steel internal tooth washers, assemble the complete ground cable connection, as per Figure 2-5.

Figure 2-5
Grounding the CTR

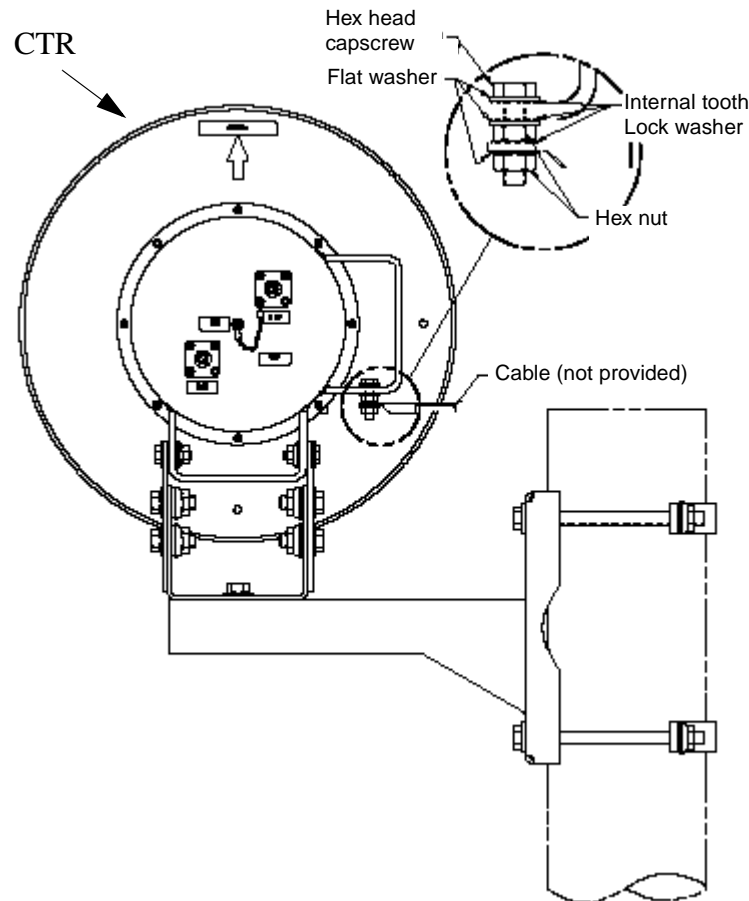

Regulatory Considerations

Electrical

1. UL1950/IEC950

Lightning protection

1. UL1492
2. IEC 65
3. IEEE/ANSI C62.41
4. Bellcore GR-1089-CORE
5. ANSI/NFPA 780 Lightning Protection Code

Grounding

1. CCITT Rec K.27
2. Corporate Standard 4122, Grounding of Communication Systems

It is assumed that building construction complies with NEC Article 250 (US) or CEC Section 10 (Canada). In the US the recommended ground resistance is 5 ohms and the maximum for a single electrode is 25 ohms.

List of terms

AC

Alternating Current

AWG

American Wire Gauge

DBMS

Digital Broadband Microwave System

DC

Direct Current

DRO

Dielectric Resonance Oscillator

EIA

Electronic Industries Association

ESD

Electrostatic Discharge

FCC

Federal Communications Commission

IC

Industry Canada

IF

Intermediate Frequency

kHz

kilohertz, one thousand hertz or cycles per second

LO

Local Oscillator

LNA

Low Noise Amplifier

LNB

Low Noise Block Downconverter

MHz

MegaHertz, one million hertz or cycles per second

NIU

Network Interface Unit

OEXO

Oven-Controlled Crystal Oscillator

PA

Power Amplifier

PS

Power Supply

QAM

Quadrature Amplitude Modulation, which entails modulating frequency

RF

Radio Frequency

RPE

Radio Power Extractor

RSM

Redundancy Switching Matrix

RSM 9016/9116

Redundancy System Monitor

SDM

Signal Demodulator Module

SMM

Signal Modulator Module

VAC

Voltage Alternating Current

VDC

Voltage Direct Current (Volts Direct Current)

VHF

Very High Frequency

Reunion
BTR 38 GHz
Installation Guide

Nortel Broadband Wireless Access
14 Fultz Blvd.
Winnipeg, Manitoba R3Y 1V3
Phone: 972-BWA-ETAS/972-292-3827; Fax: 204-631-2475
1-800-4-NORTEL (1-800-466-7835)

<http://www.nortel.com>

© 1999 Northern Telecom

Northern Telecom Ltd., all rights reserved

NORTHERN TELECOM CONFIDENTIAL:

The information contained in this document is the property of Northern Telecom. Except as specifically authorized in writing by Northern Telecom, the holder of this document shall keep the information contained herein confidential and shall protect same in whole or in part from disclosure and dissemination to third parties and use same for evaluation, operation, and maintenance purposes only.

Information is subject to change without notice.

Publication number: 411-1333- 204.01.02
Product release : Release 1.2
Document version: Preliminary
Date: March 1999
Printed in Canada

