



Nortel BWA Type Acceptance Radio Transceiver Test Report

Product Description:	28 GHz Base Station (BTR) and Customer Premise (CTR) Radio Transceivers
Model:	BTR2800 and CTR 2800
Nortel BWA File #	N9UBTRCTR2800

CHARLIE BISHOP PI ENGINEER

DATE MARCH 26, 1999

WINNIPEG,

TABLE OF CONTENTS

	Page
<u>1. INTRODUCTION.....</u>	<u>1</u>
OBJECT	1
EQUIPMENT UNDER TEST DESCRIPTION.....	1
GENERAL	2
RESULTS	2
TEST FACILITIES DESCRIPTION.....	3
TEST EQUIPMENT	3
<u>1. CONDUCTED EMISSIONS.....</u>	<u>4</u>
TEST CONDITIONS.....	4
MINIMUM SPECIFICATIONS.....	4
TEST RESULTS.....	4
MEASUREMENT DATA	4
TEST METHOD.....	4
TEST SYSTEM TEST CONFIGURATION.....	4
<u>2. RADIATED EMISSIONS.....</u>	<u>6</u>
TEST CONDITIONS.....	6
SPECIFICATIONS.....	6
TEST RESULTS.....	6
MEASUREMENT DATA	6
TEST METHOD.....	6
TEST SYSTEM CONFIGURATION.....	7
<u>3. TEMPERATURE STABILITY TESTS</u>	<u>8</u>
TEST CONDITIONS.....	8
SPECIFICATIONS.....	8
TEST RESULTS.....	8
MEASUREMENT DATA	8
TEST METHOD.....	8
TEST SYSTEM CONFIGURATION.....	9
<u>CONDUCTED EMISSIONS MEASUREMENT RESULTS.....</u>	<u>11</u>
COMPUTER SETUP AND INSTRUMENTATION IN THE PI LABORATORY	11
CONNECTION TO THE BTR USING THE WAVE-GUIDE CONNECTION	12

BTR 2800, 4 CARRIER QAM 64 MODULATED - IN-BAND CARRIERS	13
BTR 2800, 4 CARRIER QAM 64 MODULATED. – 30MHZ TO EDGE OF CARRIERS	14
BTR 2800, 4 CARRIER QAM 64 MODULATED. – EDGE OF CARRIERS TO 40GHZ	15
BTR 2800, 4 CARRIER QAM 64 MODULATED. – 40 TO 60GHZ	16
BTR 2800, 4 CARRIER QAM 64 MODULATED. – 60 TO 90GHZ	17
BTR 2800, 4 CARRIER QAM 64 MODULATED. – 90 TO 140GHZ	18
CTR CONNECTED IN THE LABORATORY FOR CONDUCTED MEASUREMENTS.....	19
CTR WITH THE CASE REMOVED	19
THE FOLLOWING PICTURES SHOW 2 – 10MHZ CARRIERS ACROSS THE MINIMUM, MAXIMUM AND MIDDLE OF THE 150MHZ BAND AT A CHANNEL POWER OF 16DBM.....	21
CTR 2800, 2 CARRIER QAM 64 MODULATED. – 30MHZ TO EDGE OF CARRIERS	22
CTR 2800, 2 CARRIER QAM 64 MODULATED. – EDGE OF CARRIERS TO 40GHZ	23
CTR 2800, 2 CARRIER QAM 64 MODULATED. – 40-60GHZ	24
CTR 2800, 2 CARRIER QAM 64 MODULATED. –60-90GHZ	25

RADIATED EMISSIONS MEASUREMENT RESULTS28

BTR 2800, 4 CARRIER QAM 64 MODULATED. – 30MHZ TO 2GHZ	29
BTR 2800, 4 CARRIER QAM 64 MODULATED. – 2GHZ TO 18GHZ.....	30
BTR 2800, 4 CARRIER QAM 64 MODULATED. – 18 TO 29 GHZ.....	31
BTR 2800, 4 CARRIER QAM 64 MODULATED. – 29.5GHZ TO 40GHZ.....	32
BTR 2800, 4 CARRIER QAM 64 MODULATED. –40GHZ-60GHZ - HORIZONTAL.....	33
BTR 2800, 4 CARRIER QAM 64 MODULATED. –40GHZ-60GHZ - VERTICAL.....	34
BTR 2800, 4 CARRIER QAM 64 MODULATED. –60GHZ-90GHZ - HORIZONTAL.....	35
BTR 2800, 4 CARRIER QAM 64 MODULATED. –60GHZ-90GHZ – VERTICAL.....	36
CTR 2800, 2 CARRIER QAM 64 MODULATED. – 30MHZ TO 2GHZ – VERTICAL.....	40
CTR 2800, 2 CARRIER QAM 64 MODULATED. – 1GHZ TO 18GHZ - HORIZONTAL	41
CTR 2800, 2 CARRIER QAM 64 MODULATED. – 1GHZ TO 18GHZ - VERTICAL	42
CTR 2800, 2 CARRIER QAM 64 MODULATED. –18GHZ TO 40GHZ - HORIZONTAL	43
CTR 2800, 2 CARRIER QAM 64 MODULATED. –18GHZ TO 40GHZ - VERTICAL	44
CTR 2800, 2 CARRIER QAM 64 MODULATED. –40GHZ TO 60GHZ - HORIZONTAL	45
CTR 2800, 2 CARRIER QAM 64 MODULATED. –40GHZ TO 60GHZ - VERTICAL	46
CTR 2800, 2 CARRIER QAM 64 MODULATED. –60GHZ TO 90GHZ - VERTICAL	48
CTR 2800, 2 CARRIER QAM 64 MODULATED. –90GHZ TO 140GHZ - HORIZONTAL	49
CTR 2800, 2 CARRIER QAM 64 MODULATED. –90GHZ TO 140GHZ - VERTICAL	50

TEMPERATURE STABILITY MEASUREMENTS RESULTS.....52

FREQUENCY STABILITY TEST SETUP.....	52
BTR FREQUENCY STABILITY	53
CTR FREQUENCY STABILITY	56

SPECTRAL MASK LIMIT CALCULATIONS58

BTR - LOW SIDE MASK59

BTR - MID-BAND MASK59

BTR - HIGH-BAND MASK60

CTR - LOW SIDE MASK61

CTR - MIDPOINT MASK62

CTR - HIGH SIDE MASK63

1. INTRODUCTION

Object

This test report is being submitted for type acceptance of the Nortel Networks BWA Reunion Radios operating in the LMDS Bands 27.5 to 28.35 GHz and 29.1 to 29.25 GHz. The ReUnion radios are designed to provide wide-band multi-carrier point-to-multi-point subscriber services in an efficient and cost effective manner. The adherence to the rules for LMDS radios in these bands are demonstrated in the following pages. Nortel Networks BWA is currently seeking type approval on this product.

Equipment Under Test Description

The Nortel Networks BWA 28 GHz radio product is of wide band design. The power amplifiers and the LNA are designed to provide gain over the entire 27.5 to 29.25 GHz band. The BTR and CTR are of a single conversion design. A single DRO serve both the transmit and receive path. The BTR and CTR provide a maximum power output of 1 and 0.5 watt respectively for a single un-modulated tone. Thus the power limitation requirement of FCC part 101 section 101.113 is satisfied. The following tables identify the EUTs:

Model #	Description	Manufacturer	Part #
BTR2800	Base Transceiver	Nortel BWA	NTVG14AG
CTR2800	Customer Transceiver	Nortel BWA	NTVG16AG

Model #	Order Code	uW Tx (GHz)	uW Rx (GHz)	RF Rx (MHz)	RF Tx (MHz)	BW	Separation
BTR2800	NTVG14AG	29.1-29.25	28.2-28.35	250-400	500-650	150	900
CTR2800	NTVG16AG	28.2-28.35	29.1-29.25	250-400	500-650	150	900

General

Tests were performed on a production sample(s) of the BTR and CTR, according to standards and directives indicated on the table in paragraph 1.1. All measurements were performed in accordance to the measurement procedures outlined in these standards or detailed in this report.

Results

The following table summarizes the EUT test results of the testing described in this report:

Standard	Test Description	Para. No.	Results
FCC part 101 section 101.111 (a) (4)	Spectral Mask		Compliant
FCC part 2, section 2.997;	Conducted Emissions except mask region	2	Compliant
FCC part 2, Section 2.997,	Radiated Emissions except mask region	3	Compliant
FCC part 101, sec 101.113	Transmit Power Limitation	C2	Compliant
FCC part 101, sec 101.113	Antenna azimuth limitation	C3	Compliant
FCC part 2, Section 2.995 (a) (1), (b) and FCC part 101 section 101.107	Frequency Stability Over Temperature	4	Compliant

Test Facilities Description

The Nortel Network BWA EMC facility is a shielded 3m room. The room is provided with input voltage of 120 and 240 V ac, which is filtered through Corcom filters before entry. Due to lab construction, the radiated measurements were performed in an open lab environment. A reference sweep was taken to demonstrate the ambient conditions.

Test Equipment

The following is a list of test equipment used to perform all tests described in this report.

Equipment	Manufacturer	Model	Serial or Asset #	Cal due (Y/M/D)
Spectrum Analyzer	Hewlett Packard	HP 8665E	02940	09/99
Spectrum Analyzer	Hewlett Packard	HP 8663E	3611A05001	08/99
Synthesized Sig. Gen.	Anritsu	69369A	981807	06/99
Power Meter	Anritsu	ML2438A	97400074	06/99
Power Sensor	Anritsu	MA2475A		06/99
Mixer Assembly 40 to 60 GHz	Millitech/Nortel BWA	MHB-19-RD3A0	MS-118086	7/99

Equipment	Manufacturer	Model	Serial or Asset #	Cal due (Y/M/D)
Mixer Assembly 60 to 90 GHz	Millitech/Nortel BWA	MHB-12-RD3A0	MS-118101	7/99
Mixer Assembly 90 to 140 GHz	Millitech/Nortel BWA	MHB-08-RD3A0	MS-118090	7/99
Power Supply	Hewlett Packard	6544A	US36390168	-----
Power Supply	Hewlett Packard	6554A	US36340233	-----
Frequency Counter	XL microwave	3460	980338143	03/99
Antenna Bilog 30 to 1000 MHz	Shaffner-Chase	CBL6111B	2261	08/99
Horn Antenna 1 to 18 GHz	EMCO	3115	9711-5345	11/99
Horn Antenna 14 to 40 GHz	Shaffner-Chase	BBHA 9170	9046	3/99

1. CONDUCTED EMISSIONS

Tested by: Charlie Bishop and Mitch Hebert

Date: Mar 9 through Mar 15, 1998

Test was performed to validate the requirements specified in FCC part 2, section 2.997; FCC part 101 Section 101.111

Test Conditions

Temperature 22 to 25C,
Primary Voltage BTR -48 V and for CTR +18 V dc

Minimum Specifications

Since there is no specification for this range, specification in FCC part 101, section 101.111 for DEMS devices operating in the 24.25 to 25.25GHz band will be used.

Test Results

The EUT does not comply with the specification referenced in the previous paragraph. The radios do comply with either of the proposed emissions profile in the Nortel Networks BWA request for waiver.

Measurement Data

See on Appendix A for test results and setup photographs.

Test Method

Nortel processing equipment stimulated the EUT (BTR and CTR) with digitally modulated 16 QAM signal. The modulator output signals are then combined, through a passive combiner, and fed into the input to the BTR and/or CTR. The output is examined directly by a spectrum analyzer for up to frequencies of 40GHz. External mixers are used for frequencies greater than 40GHz. A synthesized frequency generator stimulates the external mixer's local oscillator input. The spectrum analyzer, synthesized generator and all calculations are administered by a Labview software application on a PC.

Test System Test Configuration

Figure 1.0 presents a simplified block diagram of the conducted emissions test set-up. For measurements above 40GHz, a PC controlled a synthesized generator programming the LO frequency input to the external mixer, so that the difference frequency between what is measured and the LO frequency is 100MHz. Below 40GHz, the output of the EUT was directly connected to the input of the spectrum analyzer.

A reference passband response is recorded, of four 16 QAM modulated carriers, occupied bandwidth of 40MHz for the BTR and two for the CTR occupying 20MHz. The measured reference is used to determine the out of band emissions, by measuring the relative differences between the reference and the measured emission.

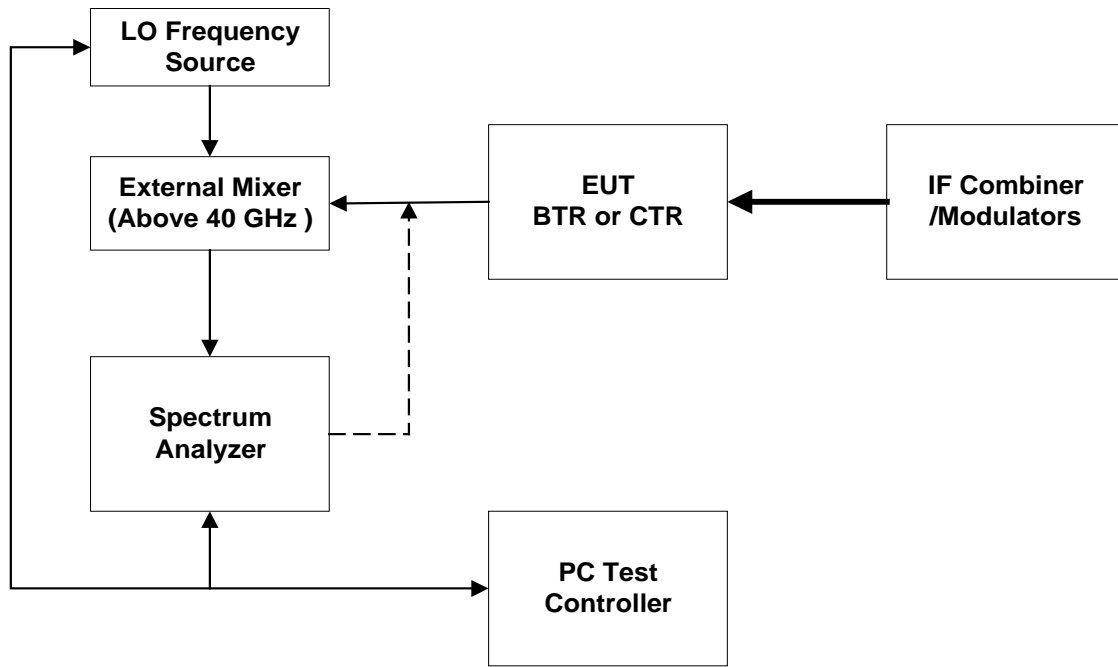

2. RADIATED EMISSIONS

Tested by: Charlie Bishop and Mitch Hebert

Date: Mar 9 through Mar 15, 1998

Test was performed to validate the requirements specified in FCC part 2, section 2.997; and FCC part 101 Section 101.111.

Test Conditions

Temperature 20-25C,
Primary Voltage BTR -48 V dc and for CTR +18 V dc

Specifications

Since there is no specification for this range, specification in FCC part 2, section 2.997, and FCC part 101, section 101.111 for DEMS devices operating in the 24.25 to 25.25GHz band.

Test Results

The EUT does not comply with the specification referenced in the previous paragraph. The radios do comply with either of the proposed emissions profile in the Nortel Networks BWA request for waiver.

Measurement Data

See on Appendix B for test results and setup photographs.

Test Method

Nortel processing equipment stimulated the EUT (BTR and CTR) with digitally modulated 16 QAM signal. The modulator output signals are then combined, through a passive combiner, and fed into the input to the BTR and/or CTR. The output is examined directly by a spectrum analyzer for up to frequencies of 40GHz. External mixers are used for frequencies greater than 40GHz. A synthesized frequency generator stimulates the external mixer's local oscillator input. The spectrum analyzer, synthesized generator and all calculations are administered by a Labview software application on a PC.

Test System Configuration

Figure 2.0 presents a simplified block diagram of the radiated emissions test set-up. For measurements above 40GHz, the antennae is positioned 30cm from the EUT; a PC controlled a synthesized generator programming the LO frequency input to the external mixer, so that the difference frequency between what is measured and the LO frequency is 100 MHz. External mixers are connected to Millitech horn antennae, covering the band 40 to 60GHz, 60 to 90GHz and 90 to 140GHz. Below 40 GHz, the antennae is positioned 1m from the EUT; the input to the spectrum analyzer was connected to various antenna a Chase 30 to 1000MHz bilog, EMCO 1 to 18GHz horn, and Chase 14 to 40GHz horn.

A reference passband response is recorded, of four 64 QAM modulated carriers, occupied bandwidth of 40 MHz for the BTR and two for the CTR occupying 20 MHz. The test antennae and the EUT antenna are positioned at a given distance, to produce a maximum amplitude response of the passband. The antennae are held in this position during the entire testing of up to 110 GHz. The measured reference is used to determine the out of band emissions, by measuring the relative differences between it and the measured emission.

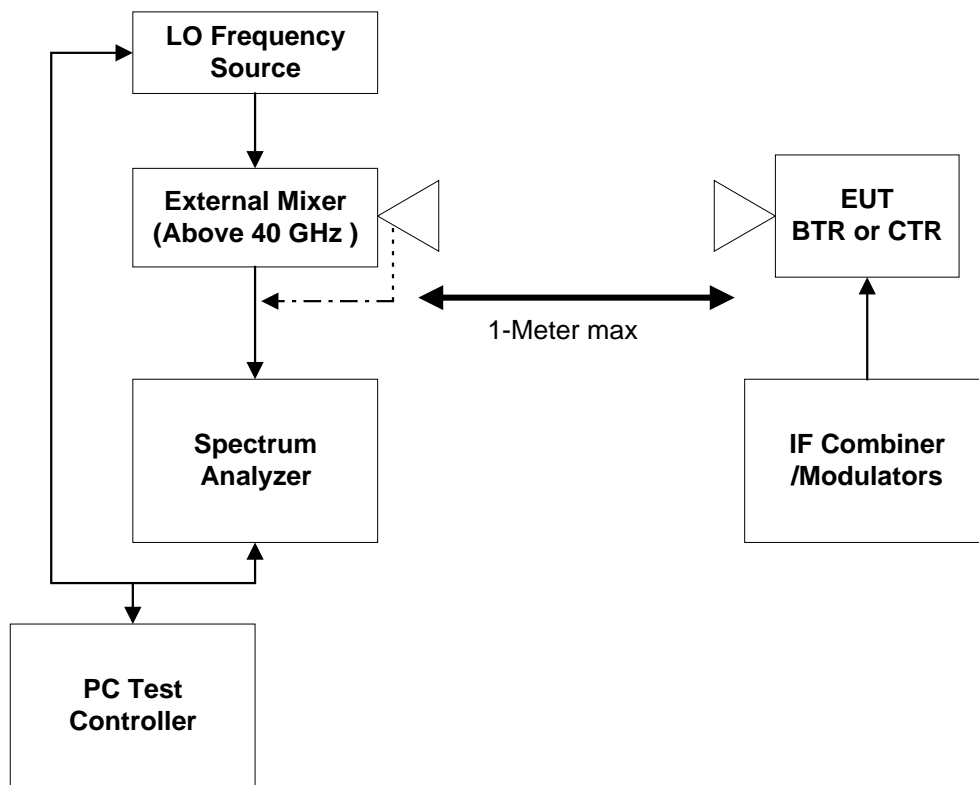

Figure 2.0: Test Setup Configuration for Radiated Emissions

3. TEMPERATURE STABILITY TESTS

Tested by: Charlie Bishop and Mitch Hebert

Date: Mar 8, 1998

Test was performed to the validate the requirement of part 101, section

Test Conditions

Temperature -40C to +50C,
Primary Voltage BTR -48 V dc and for CTR +18 V dc

Specifications

Requirement specified in FCC part 101, section 101.107, frequency tolerance of $\pm 0.03\%$

Test Results

The BTR and CTR complies with the specifications stated in specification paragraph

Measurement Data

See on Appendix C for test setup and photographs.

Test Method

Tests were performed on a BTR and CTR, these units were placed into a temperature chamber, and the temperature profile used for temperature is referenced in FCC part 2, section. A base line frequency measurement is made at first ambient temperature. With the power not applied to the EUT, the temperature is then decreased by the programmed interval (10C) and allowed to "soak" for a period time specified by the user.(20min) This time allows the internal component temperature to stabilize. Once the plateau has been achieved, the power is applied to the EUT and the frequency is measured to 6 significant digits.

Test System Configuration

Figure 3.0 presents a simplified block diagram of the temperature stability test set-up. The PC controls the temperature profile of the temperature chamber. The specified temperature profile is -40°C to $+50^{\circ}\text{C}$.

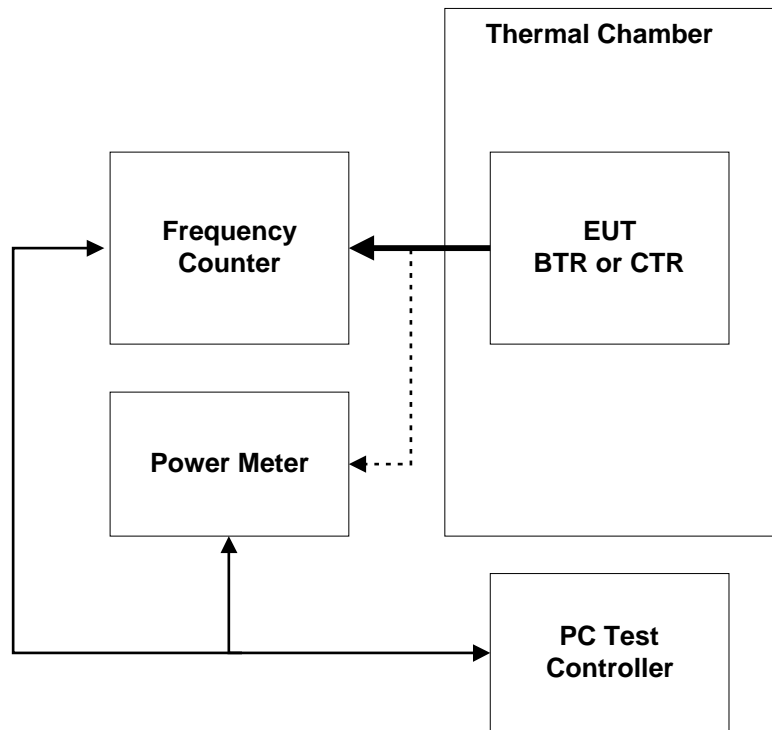

Figure 3.0: Test Setup Configuration for Temperature Stability Tests

APPENDIX A

Conducted Emissions Measurement Results

CONDUCTED EMISSIONS MEASUREMENT RESULTS



Computer setup and instrumentation in the PI laboratory

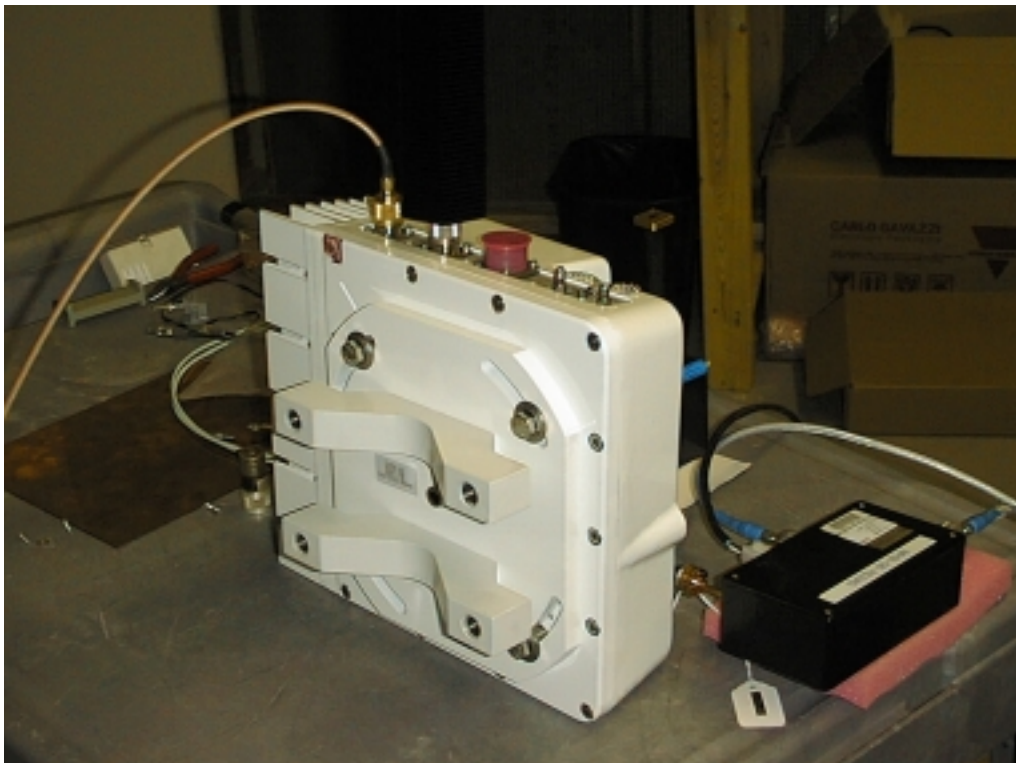

Connection to the BTR using the wave-guide connection

BTR 2800, 4 carrier QAM 64 modulated - In-band carriers

The emission showing amplitude and angle-modulated (D) with two or more channels (7) which could contain data or telephony (W). The signal has a maximum occupied bandwidth of 40MHz. (40M0). Equipment Type 40M0D7W The following pictures show 4 – 10MHz carriers across the minimum, maximum and middle of the 150MHz band at a channel power of 20dBm Limit calculations can be found in Appendix D.

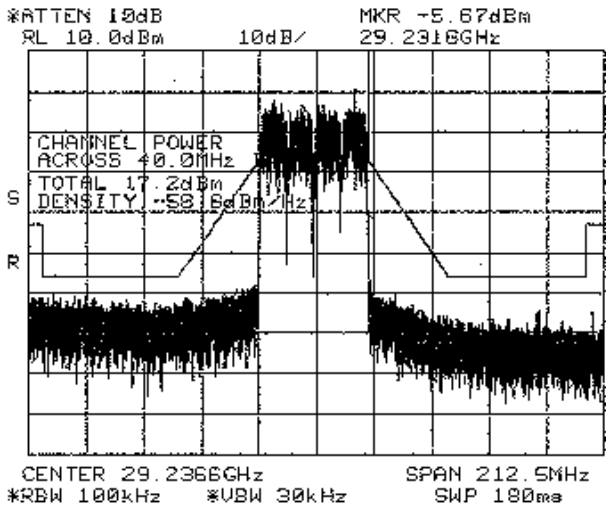
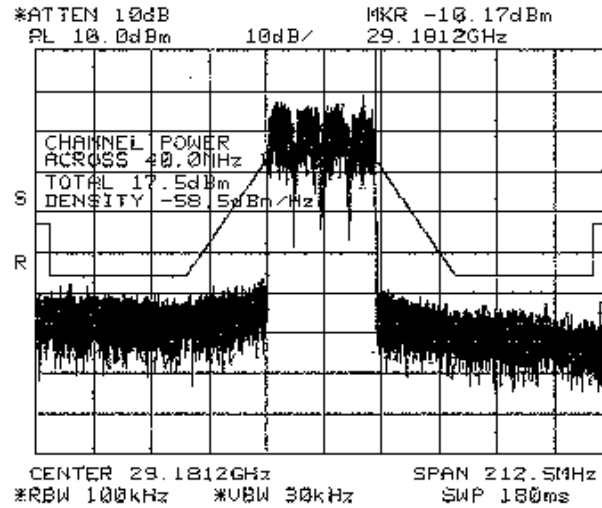
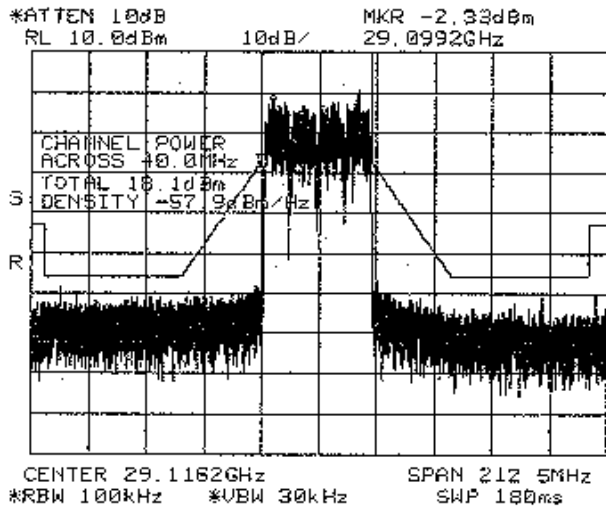

BTR 2800, 4 carrier QAM 64 modulated. – 30MHz to edge of carriers

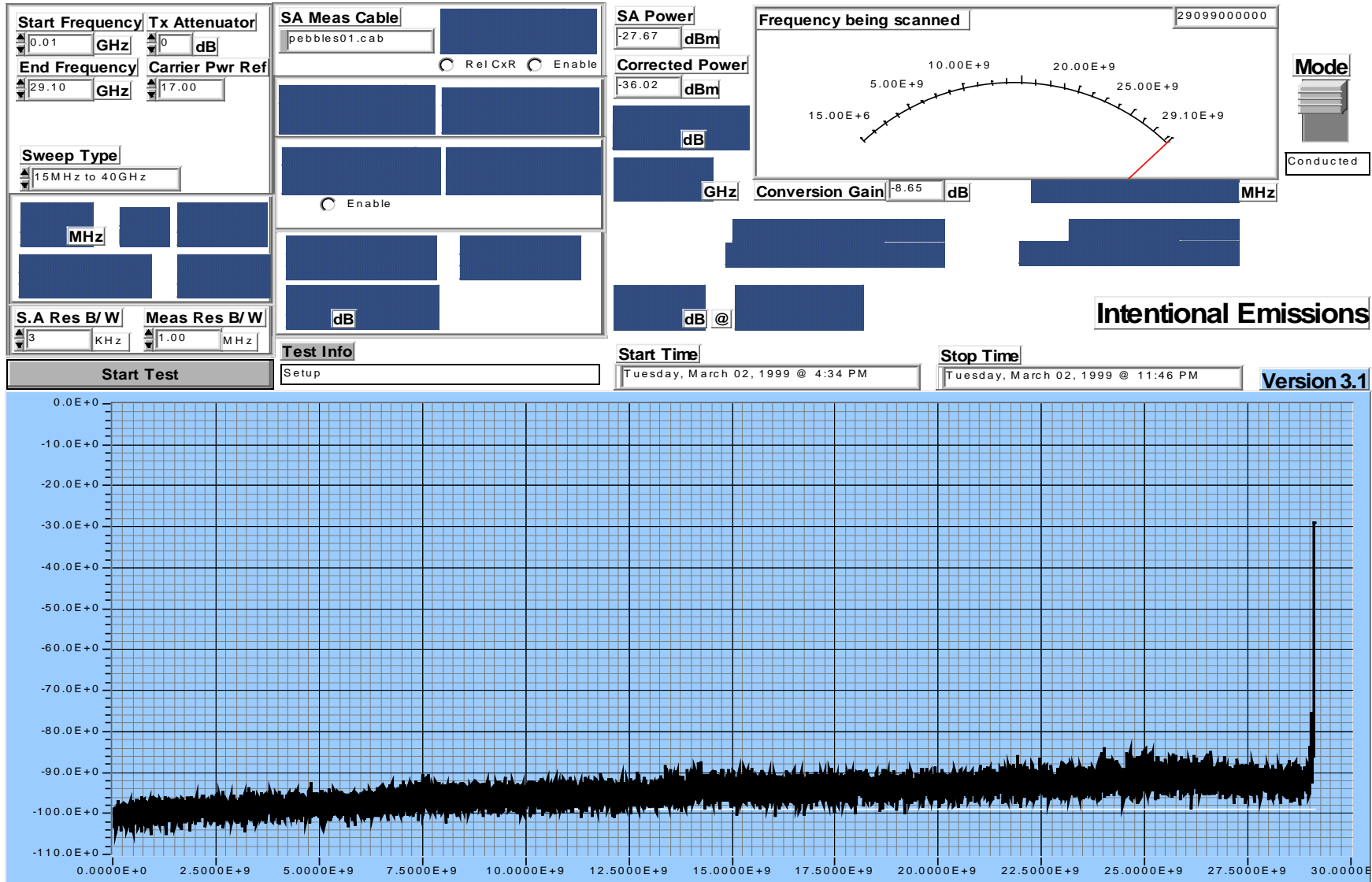

BTR 2800, 4 carrier QAM 64 modulated. – edge of carriers to 40GHz

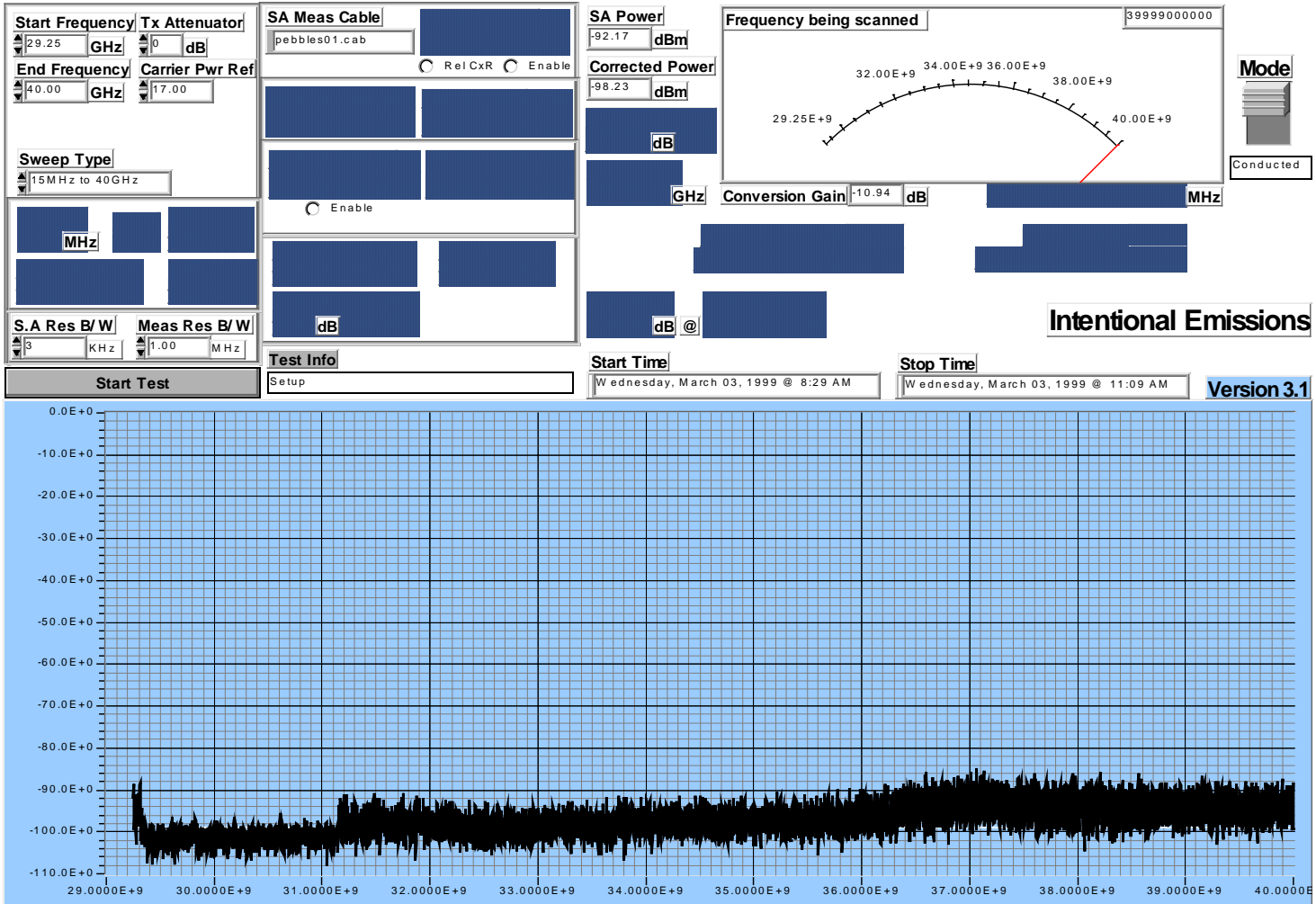

BTR 2800, 4 carrier QAM 64 modulated. – 40 to 60GHz

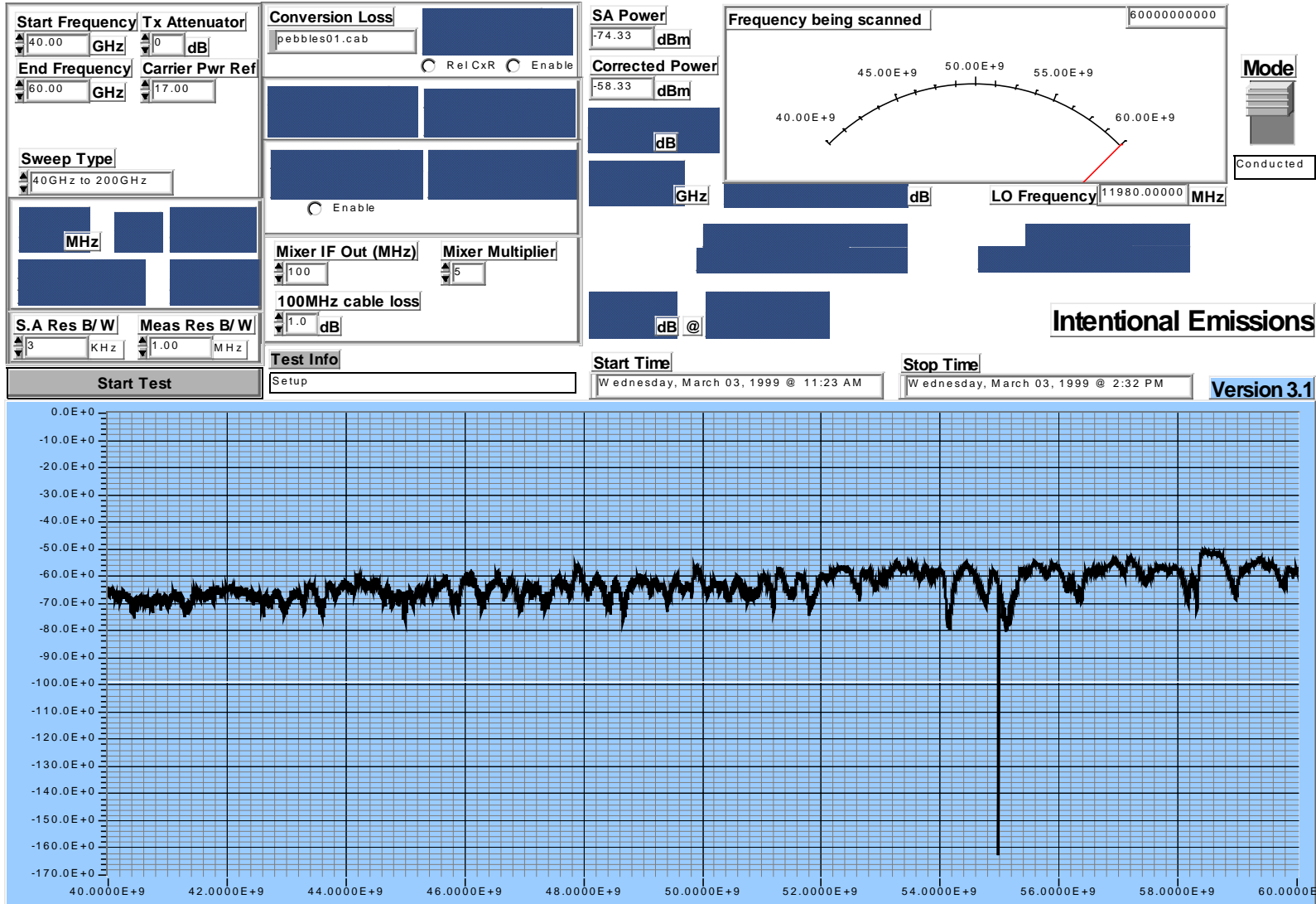

BTR 2800, 4 carrier QAM 64 modulated. – 60 to 90GHz

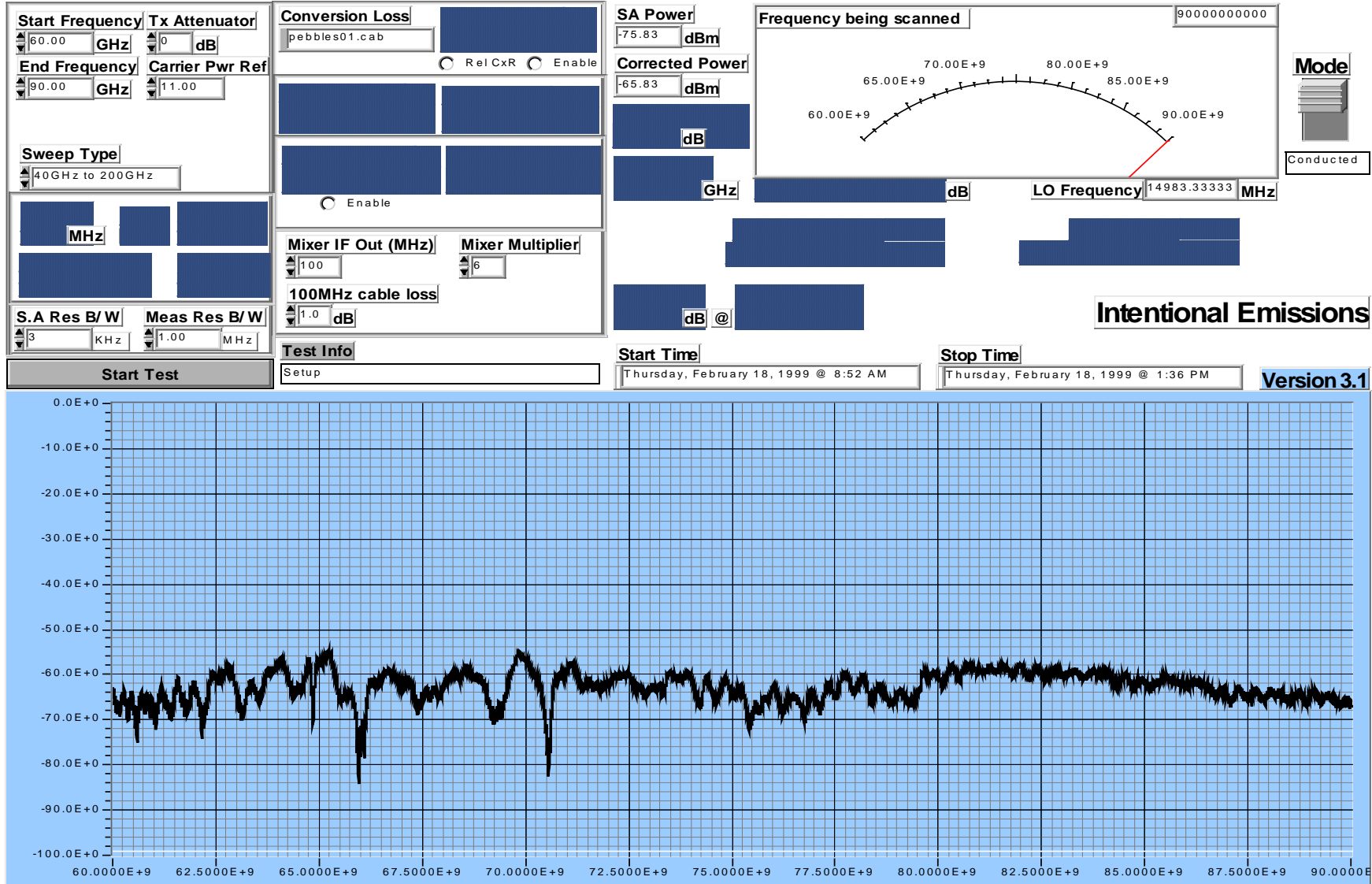

BTR 2800, 4 carrier QAM 64 modulated. – 90 to 140GHz

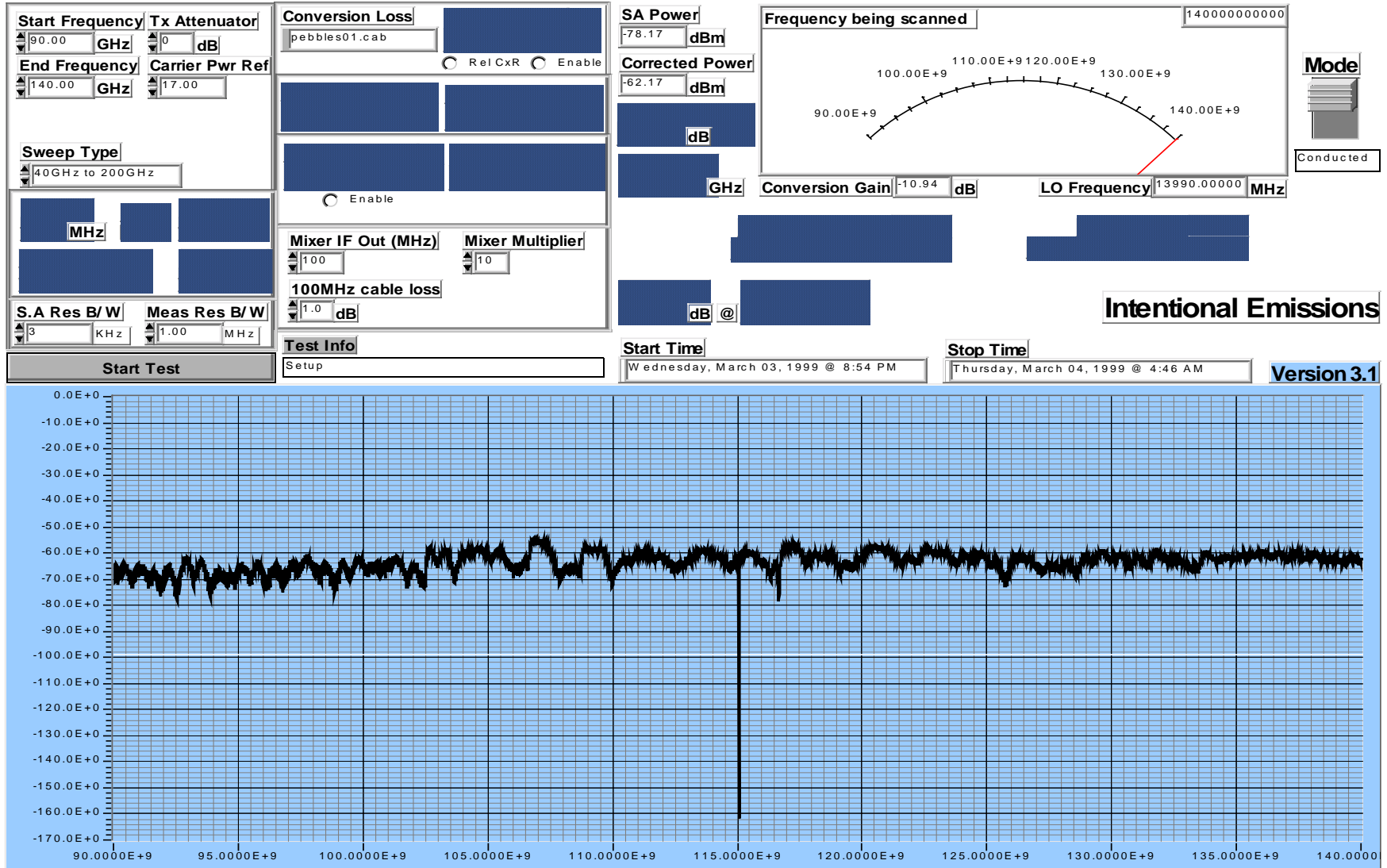

CTR connected in the laboratory for conducted measurements

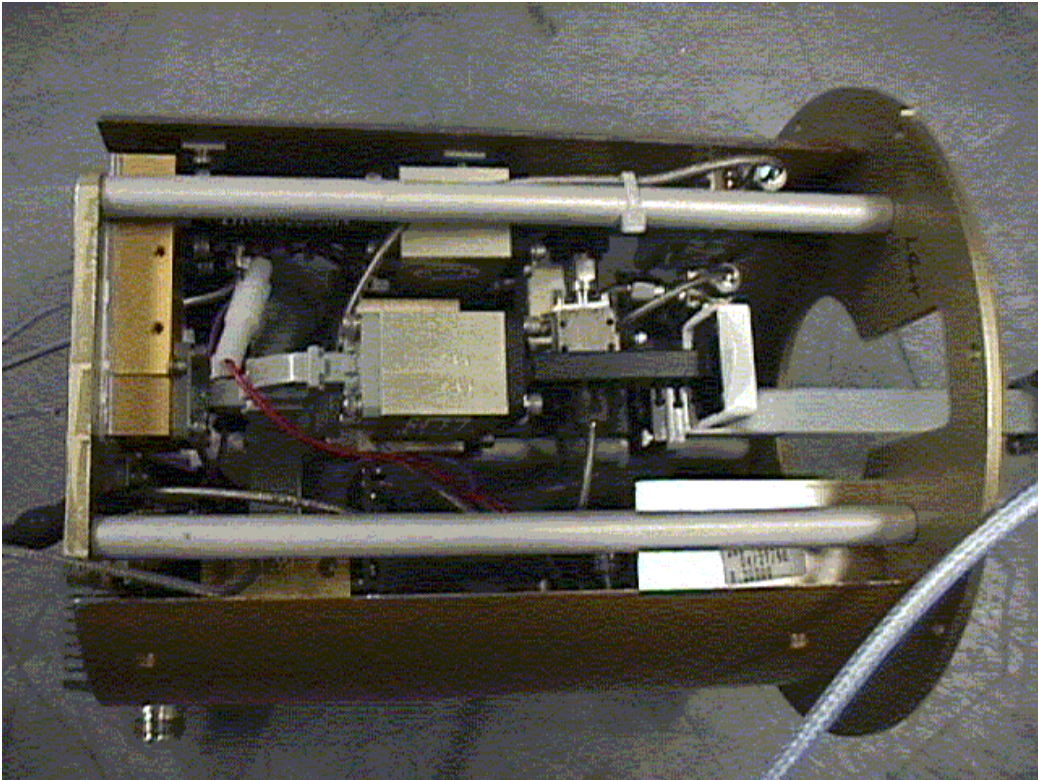
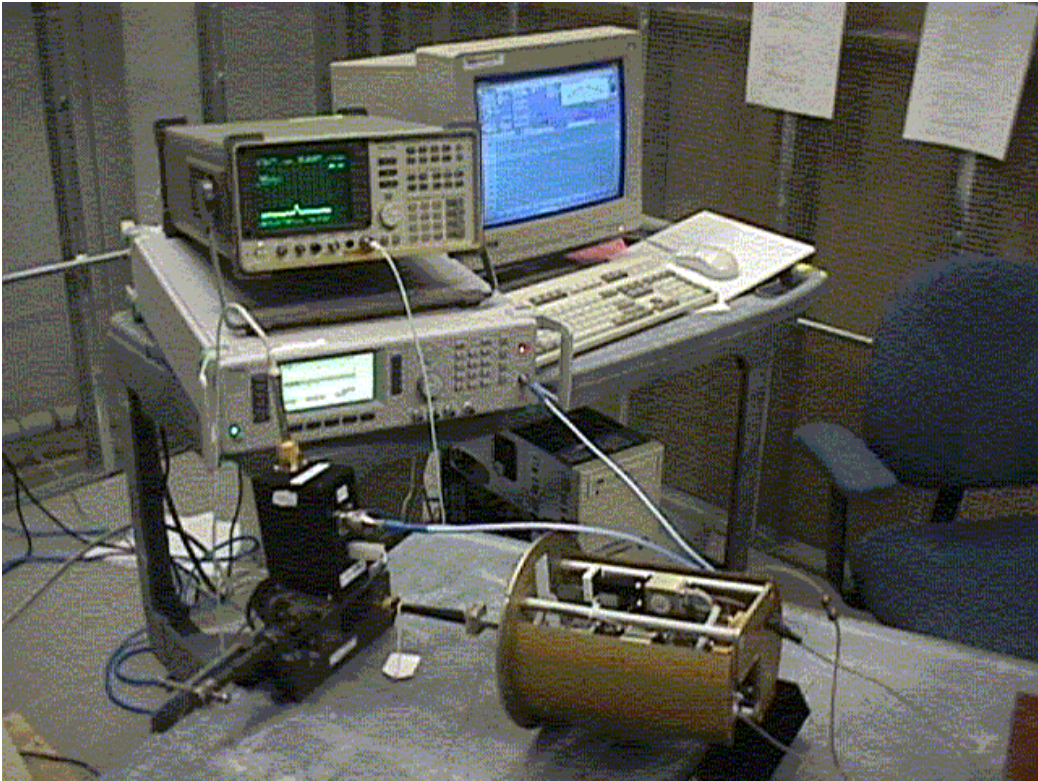

CTR with the case removed

The following pictures show 2 – 10MHz carriers across the minimum, maximum and middle of the 150MHz band at a channel power of 13dBm.

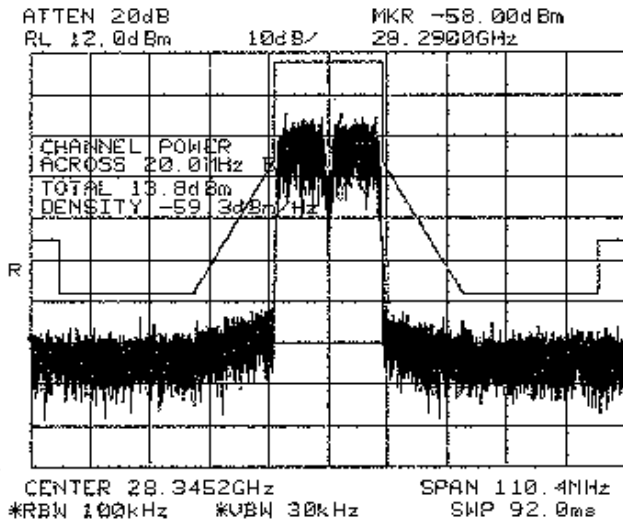
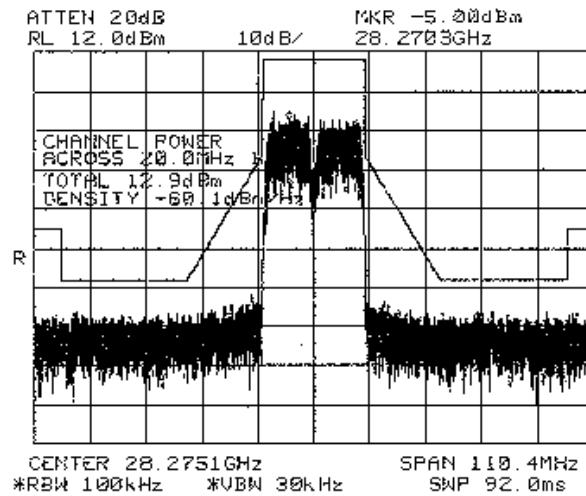
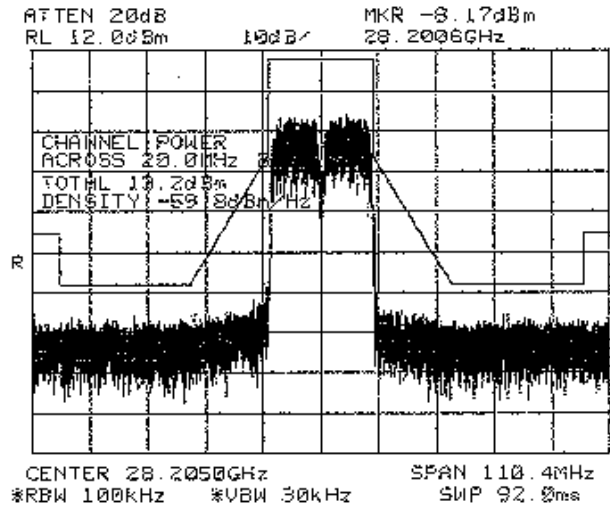

CTR 2800, 2 carrier QAM 64 modulated. – 30MHz to edge of carriers

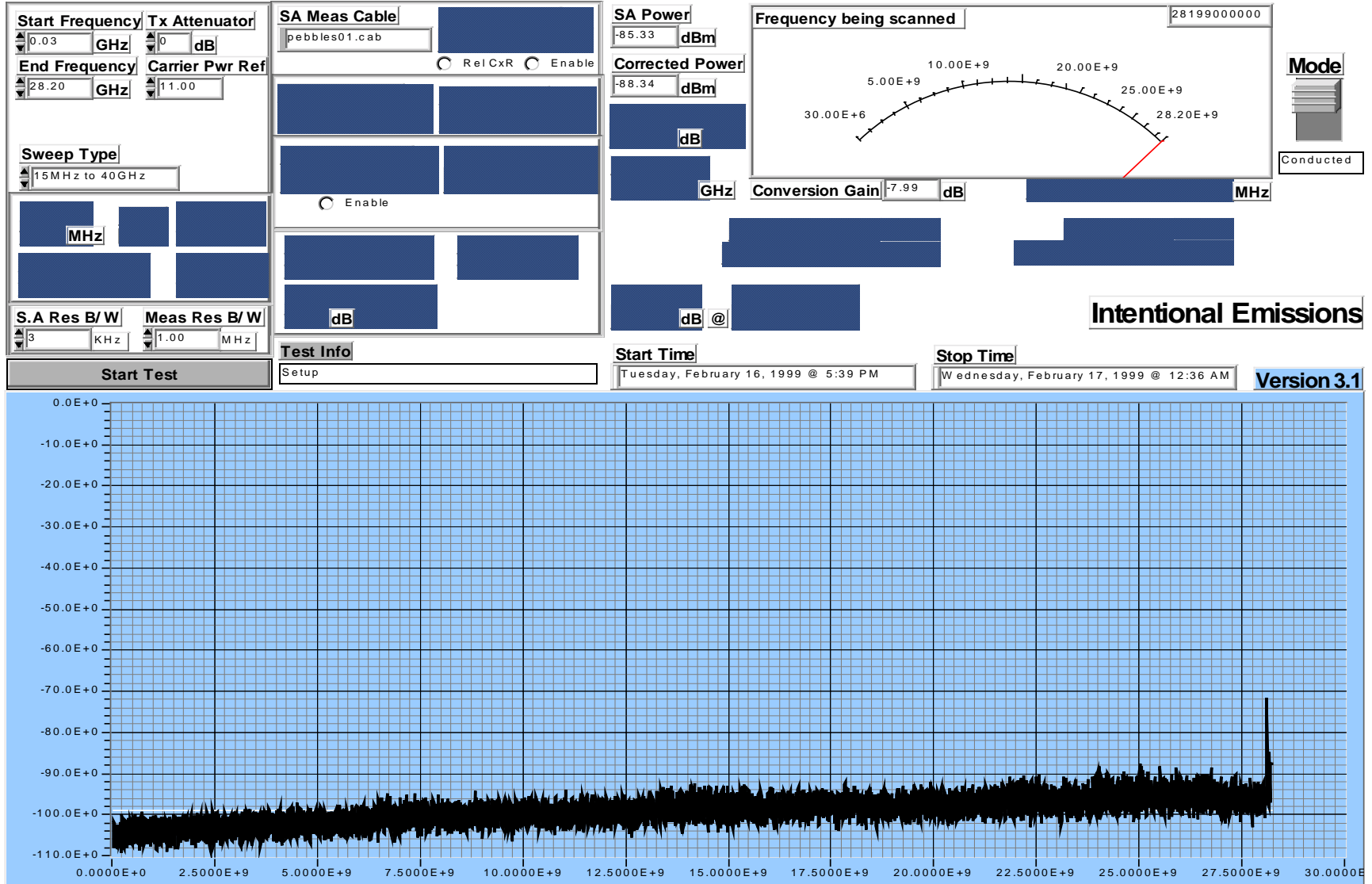

CTR 2800, 2 carrier QAM 64 modulated. – edge of carriers to 40GHz

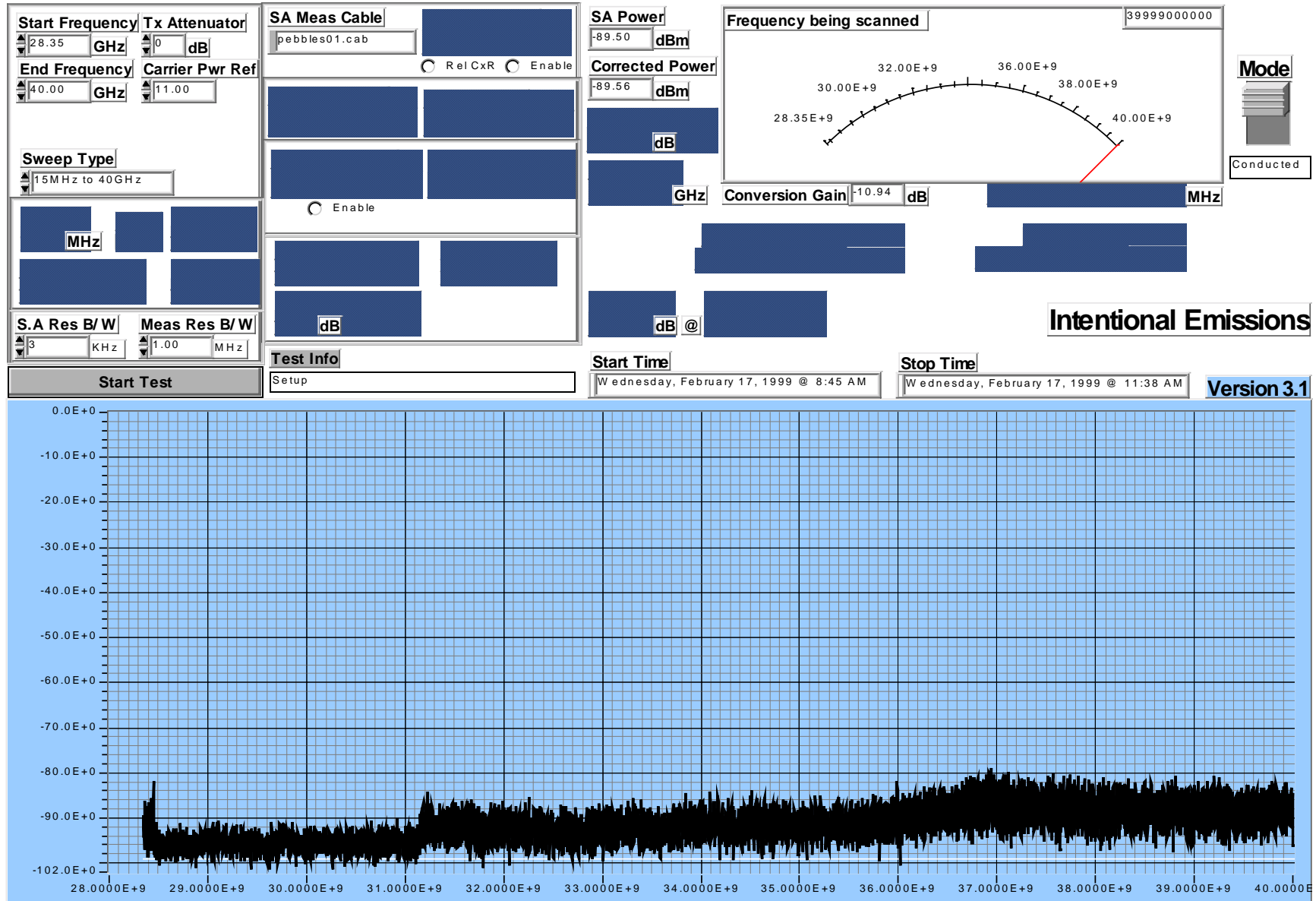

CTR 2800, 2 carrier QAM 64 modulated. – 40-60GHz

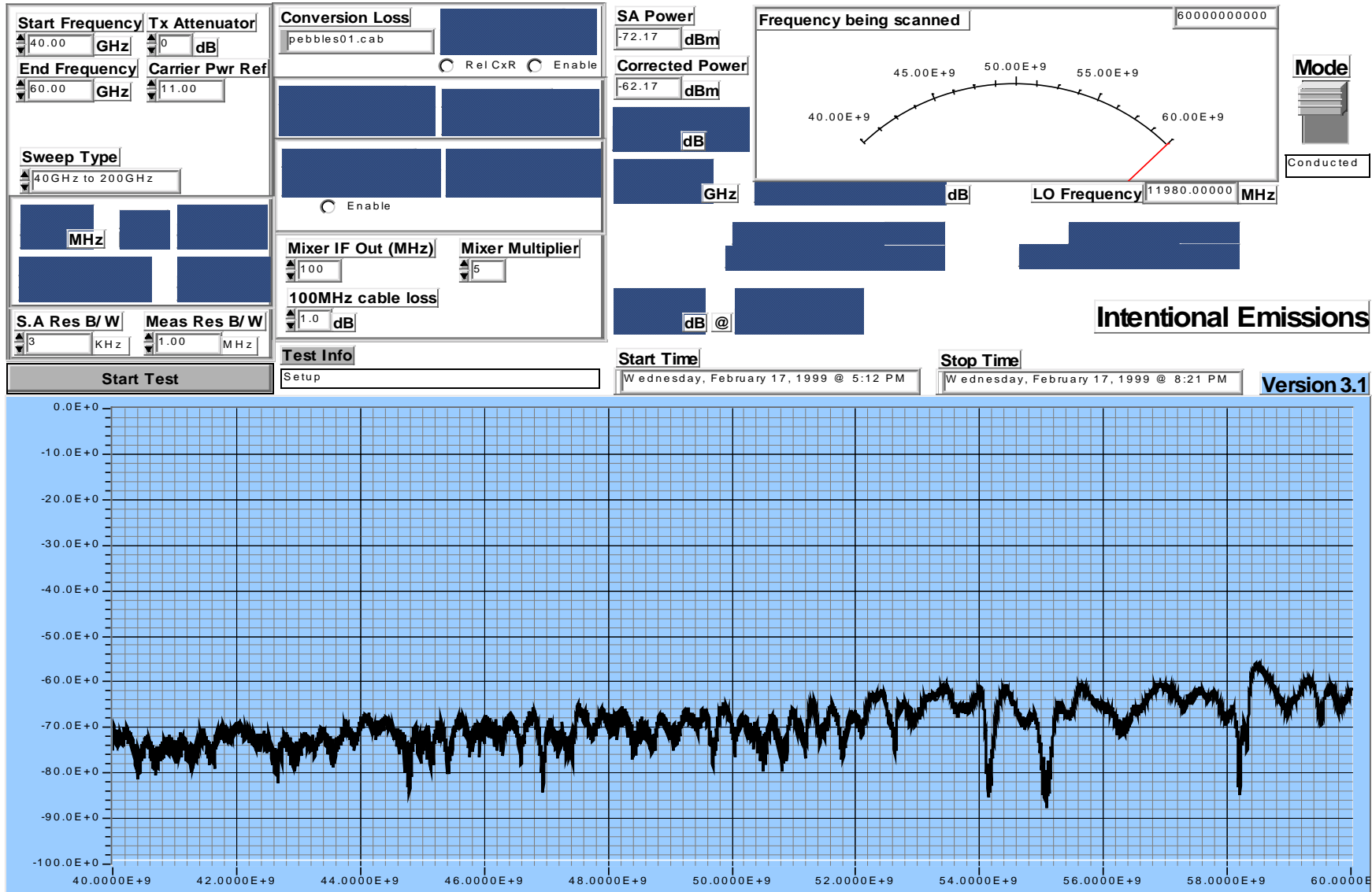

CTR 2800, 2 carrier QAM 64 modulated. -60-90GHz

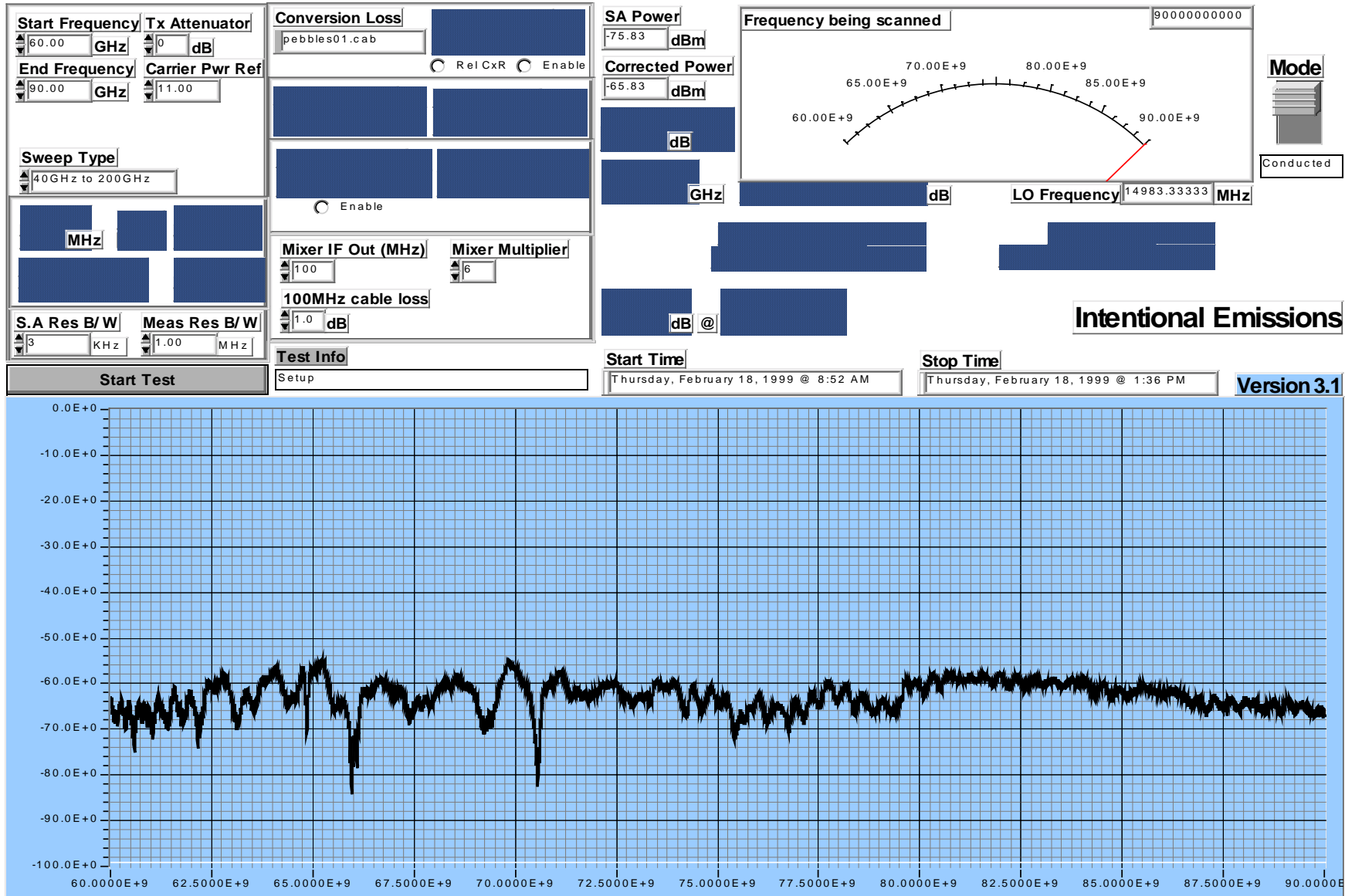

CTR 2800, 2 carrier QAM 64 modulated. -90-110GHz

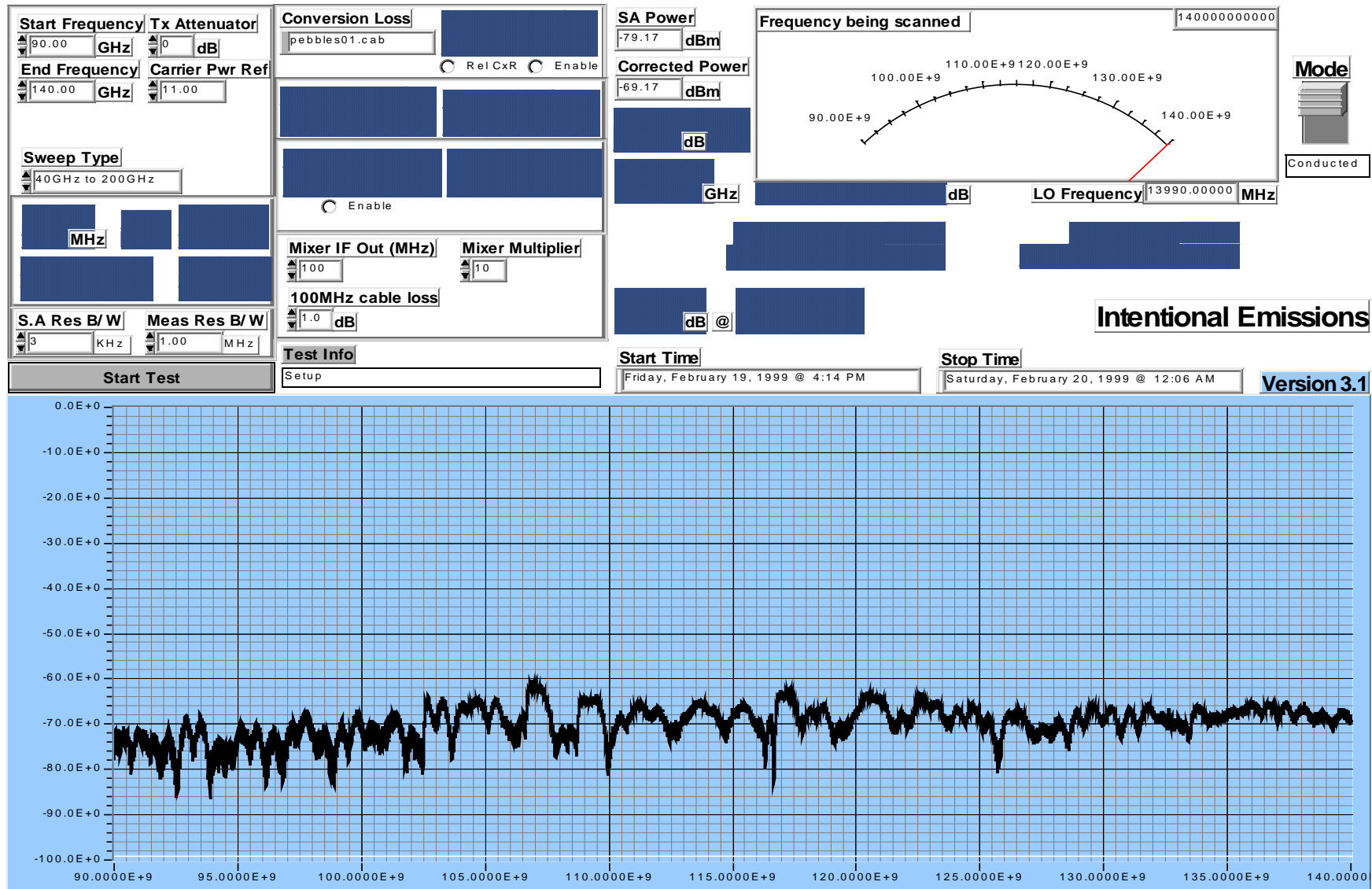

APPENDIX B

Radiated Emissions Measurement Results

RADIATED EMISSIONS MEASUREMENT RESULTS

Radiated test using the 40-60GHz horn.

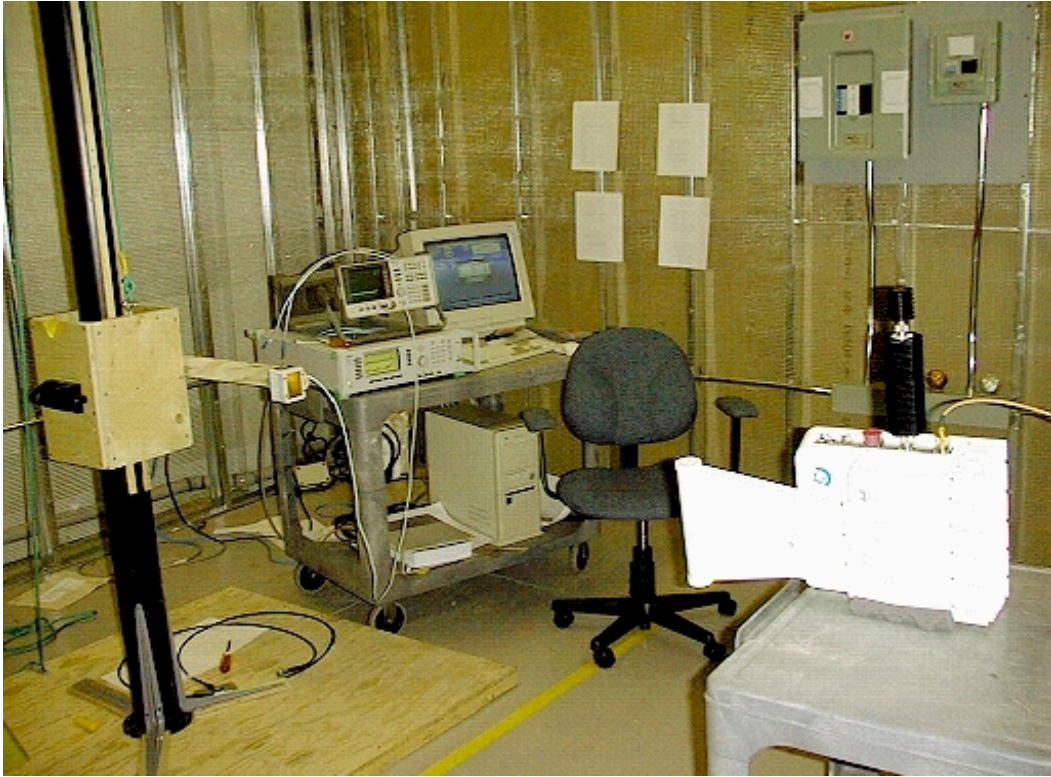

BTR with the back cover removed

BTR 2800, 4 carrier QAM 64 modulated. – 30MHz to 2GHz

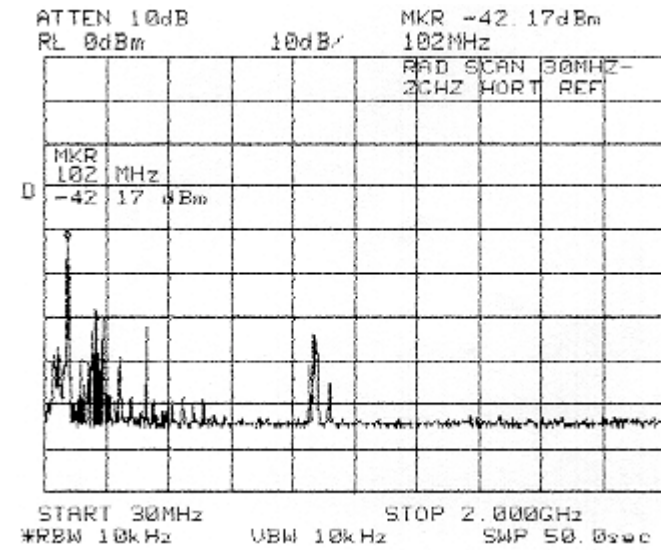
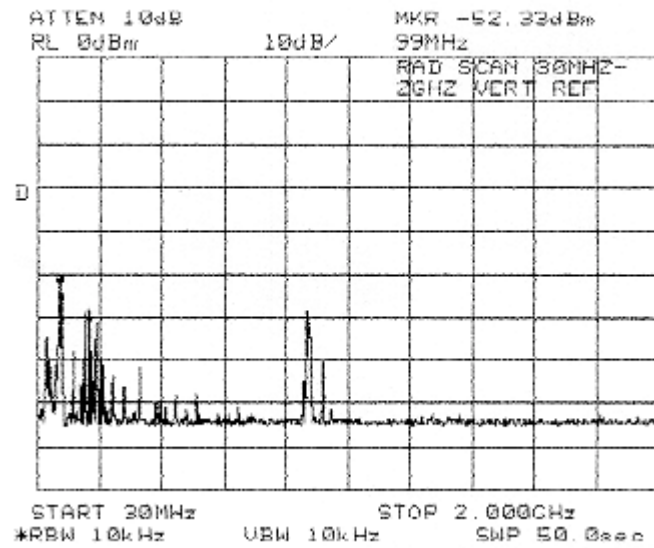

BTR 2800, 4 carrier QAM 64 modulated. – 2GHz to 18GHz

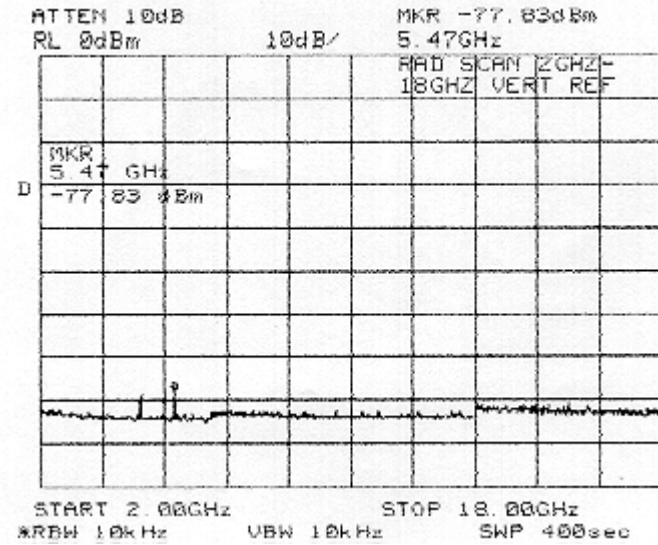
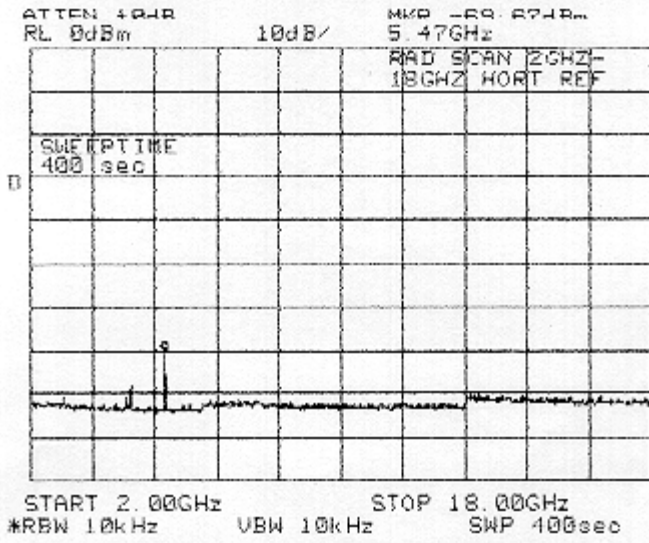

BTR 2800, 4 carrier QAM 64 modulated. – 18 to 29 GHz

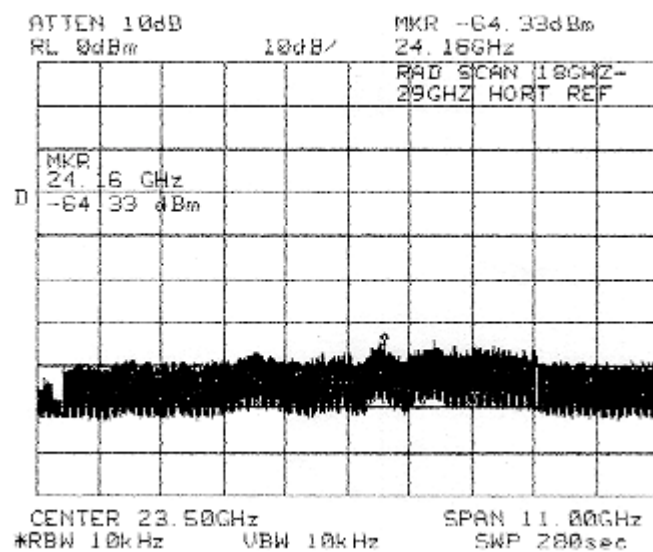
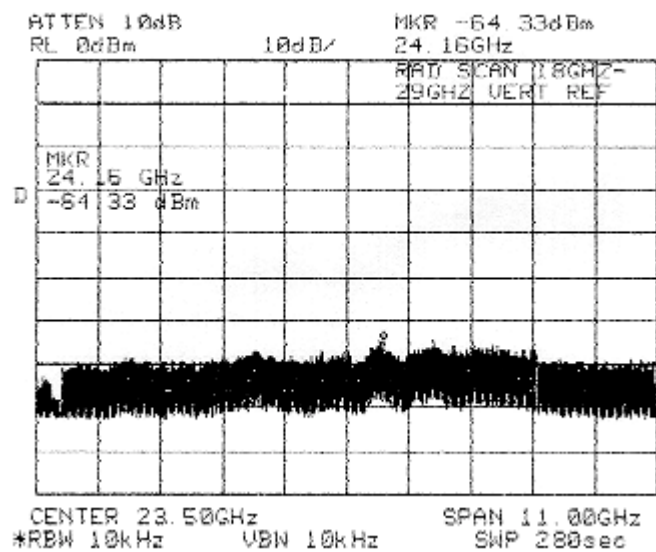

BTR 2800, 4 carrier QAM 64 modulated. – 29.5GHz to 40GHz

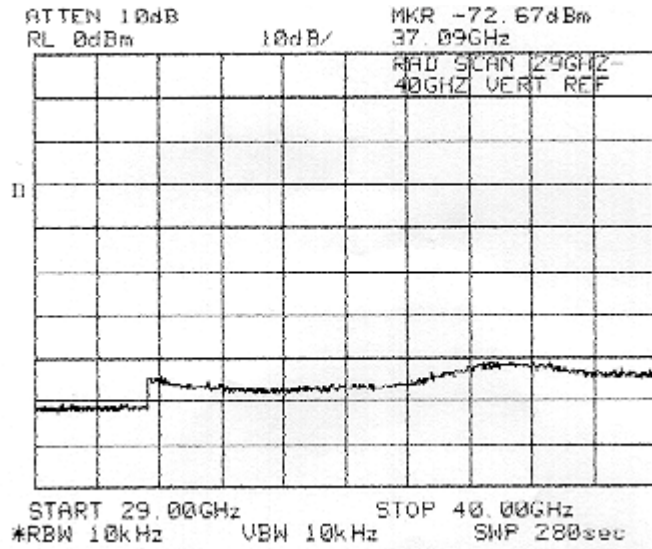
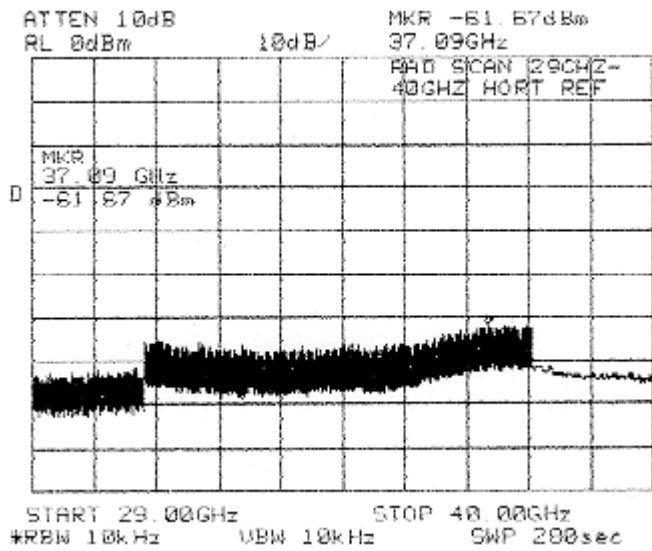

BTR 2800, 4 carrier QAM 64 modulated. -40GHz-60GHz - Horizontal

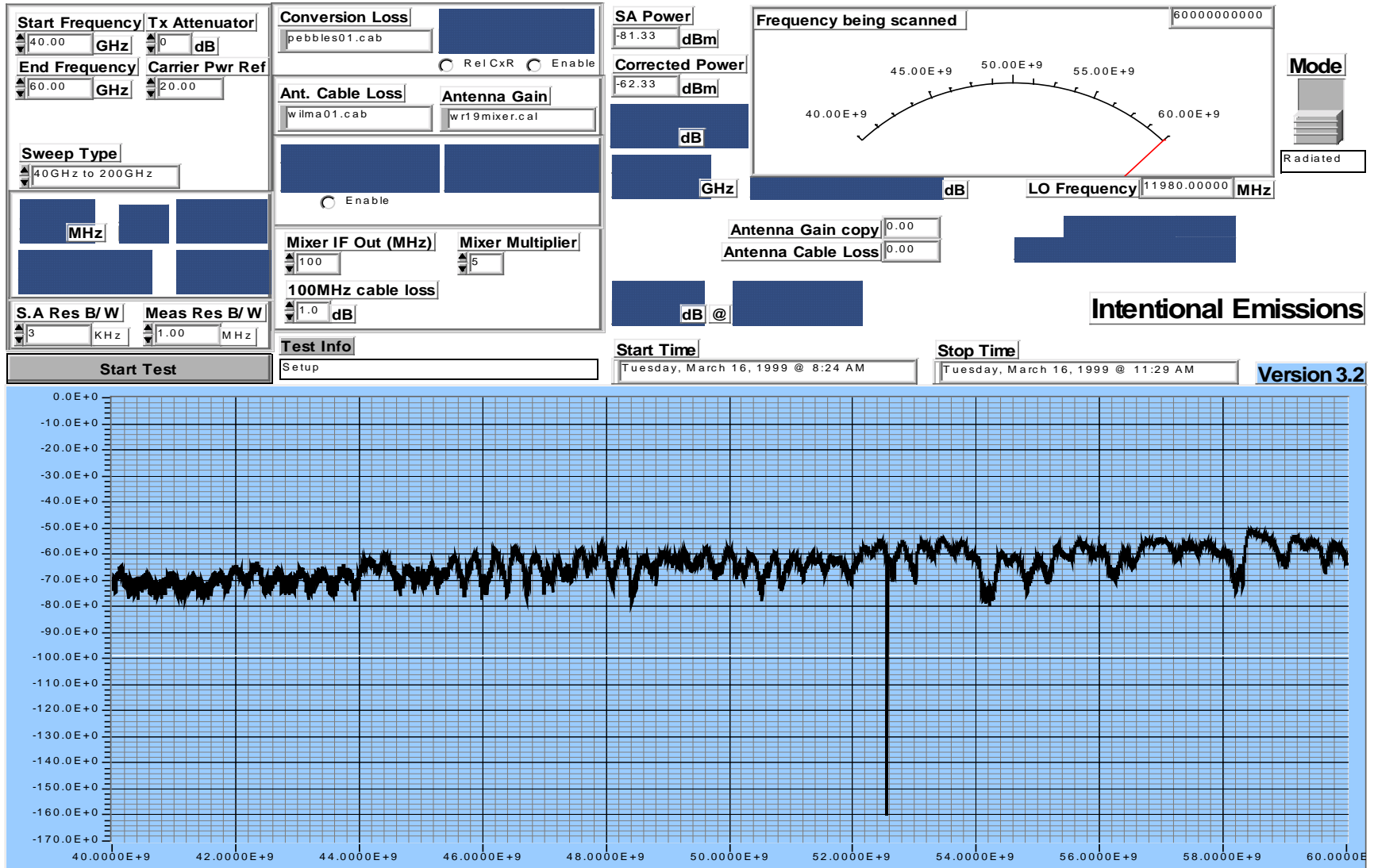

BTR 2800, 4 carrier QAM 64 modulated. -40GHz-60GHz - Vertical

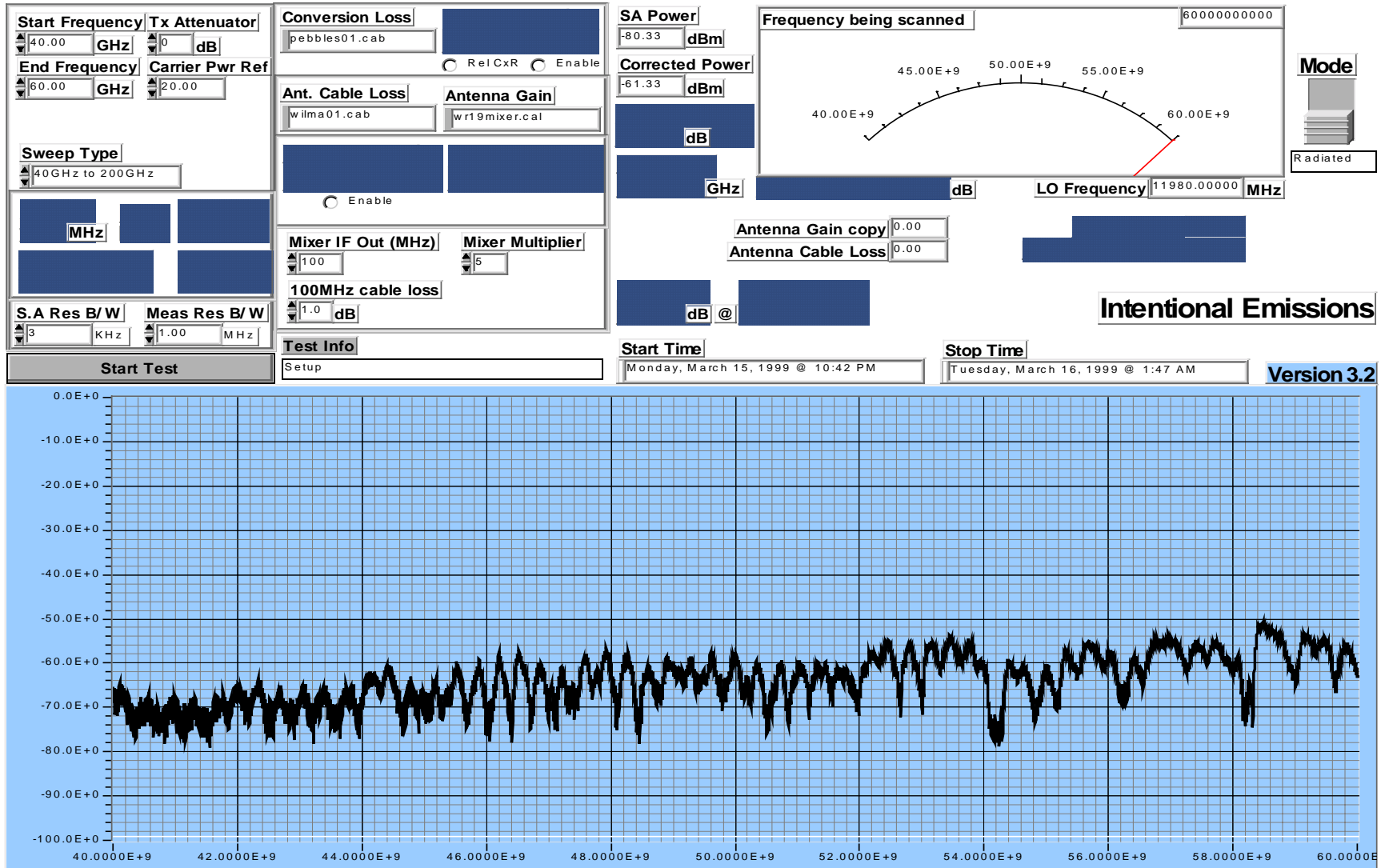

BTR 2800, 4 carrier QAM 64 modulated. -60GHz-90GHz - Horizontal

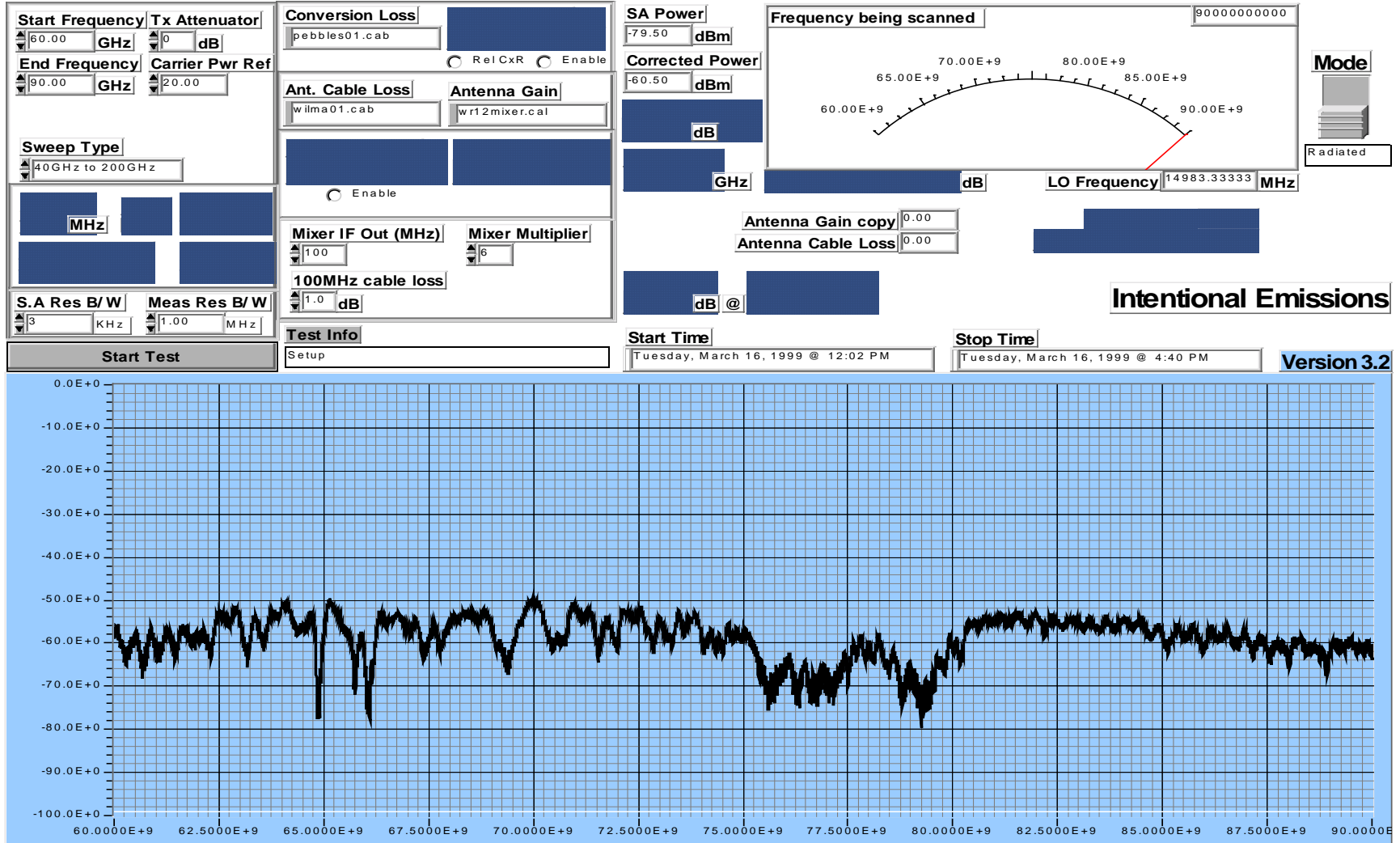

BTR 2800, 4 carrier QAM 64 modulated. -60GHz-90GHz – Vertical

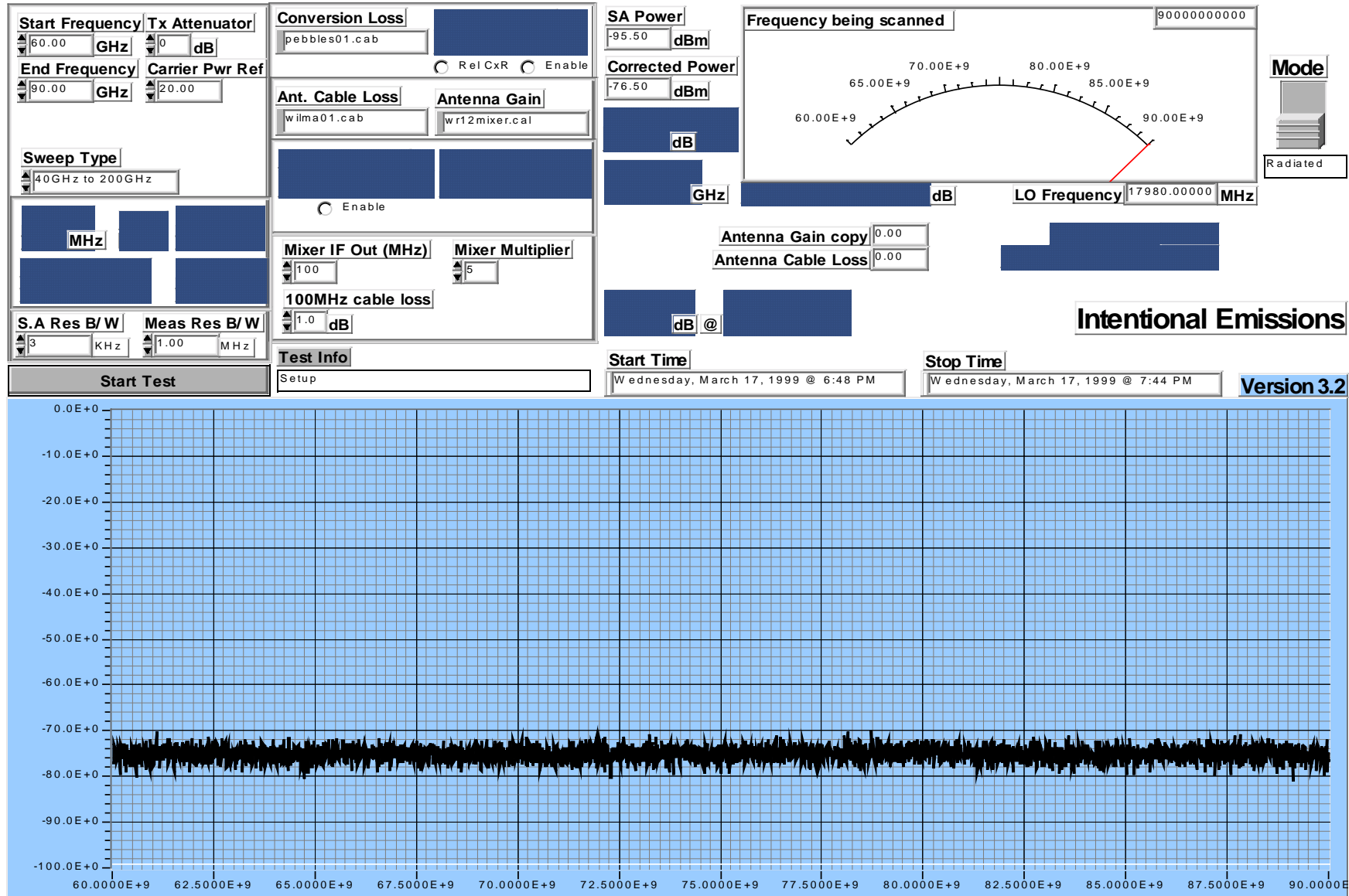

BTR 2800, 4 carrier QAM 64 modulated. -90GHz-140GHz – Horizontal

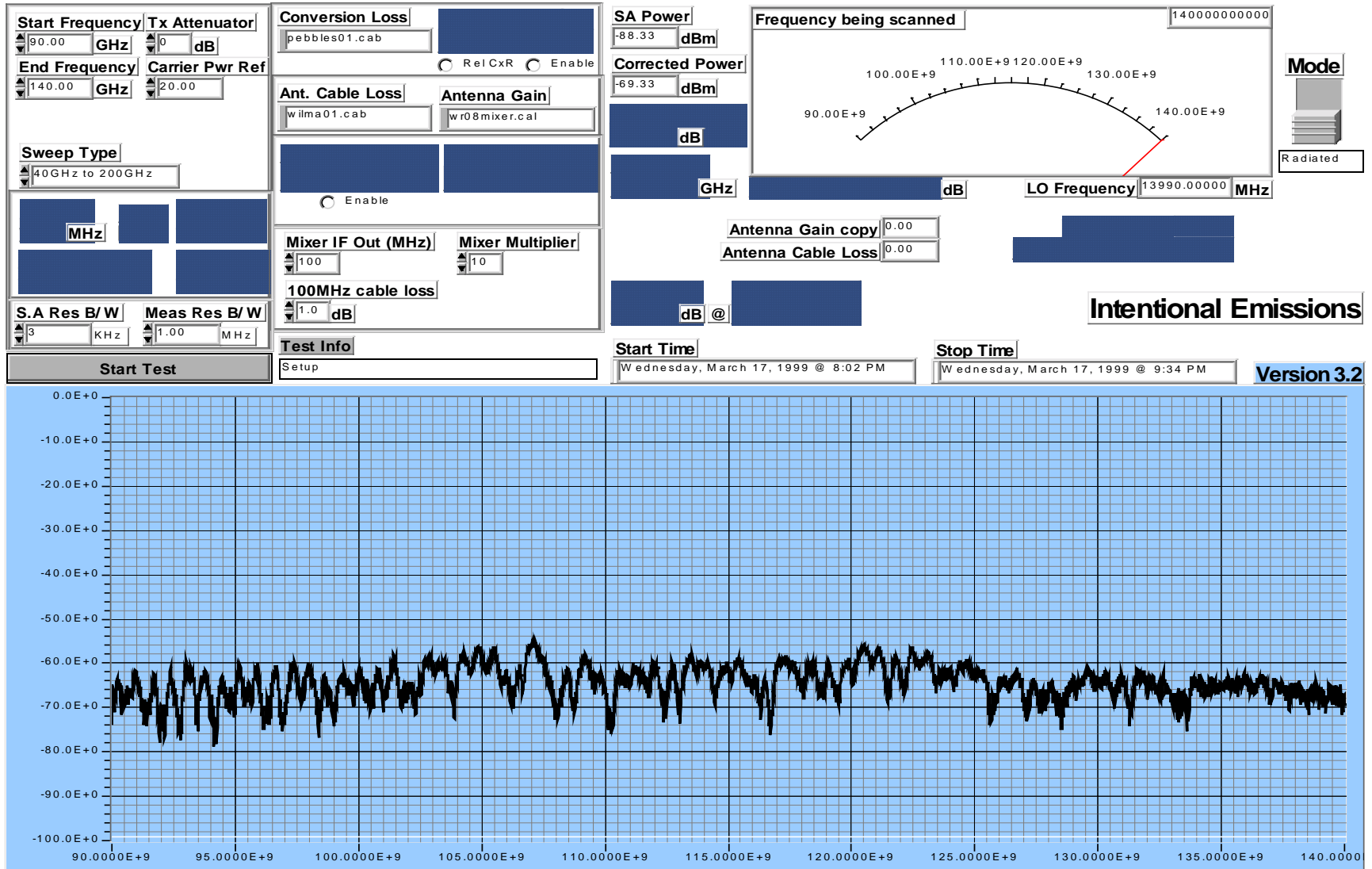

BTR 2800, 4 carrier QAM 64 modulated. -90GHz-140GHz - Vertical

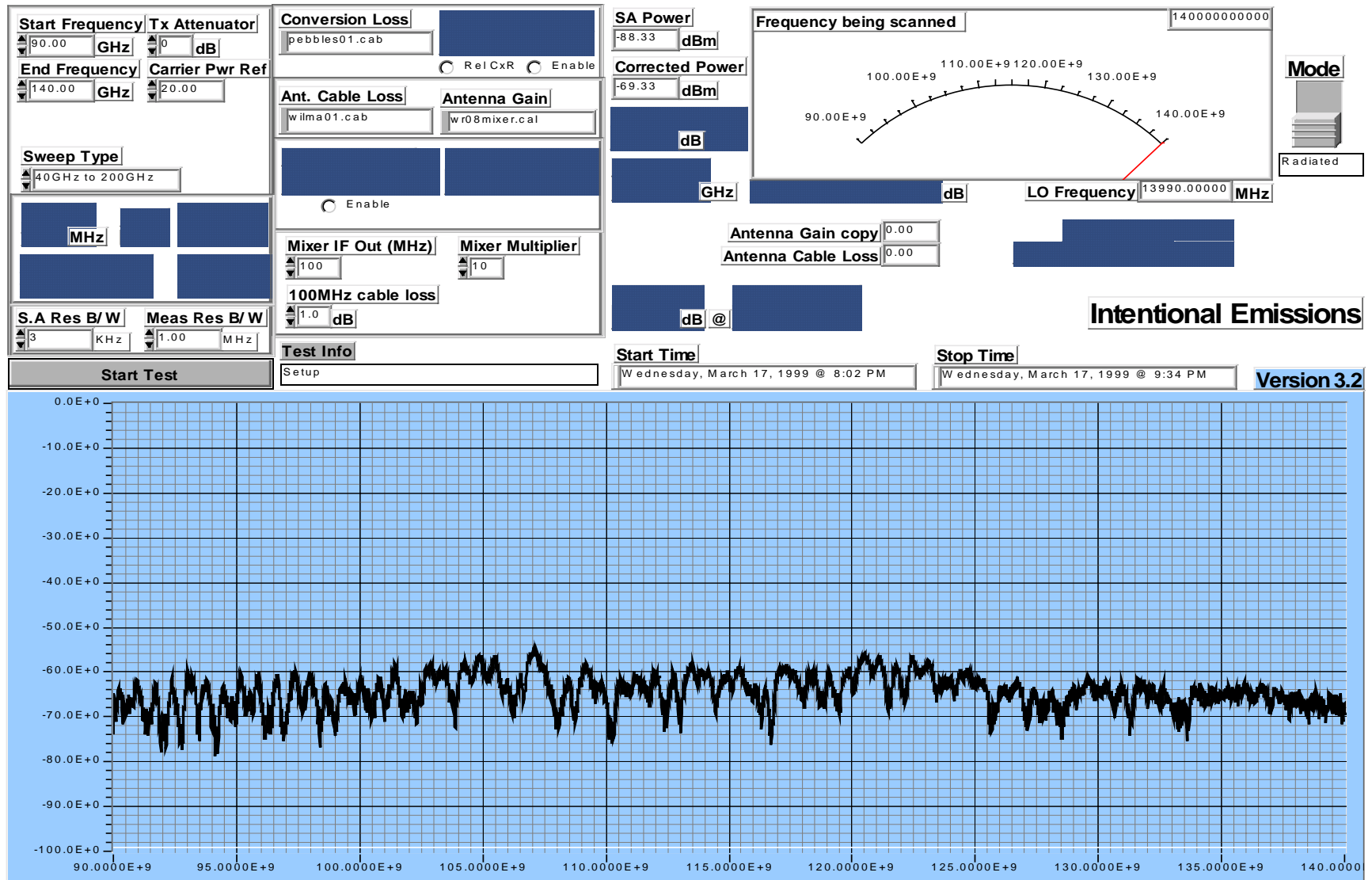

CTR 2800, 2 carrier QAM 64 modulated. – 30MHz to 2GHz – Horizontal

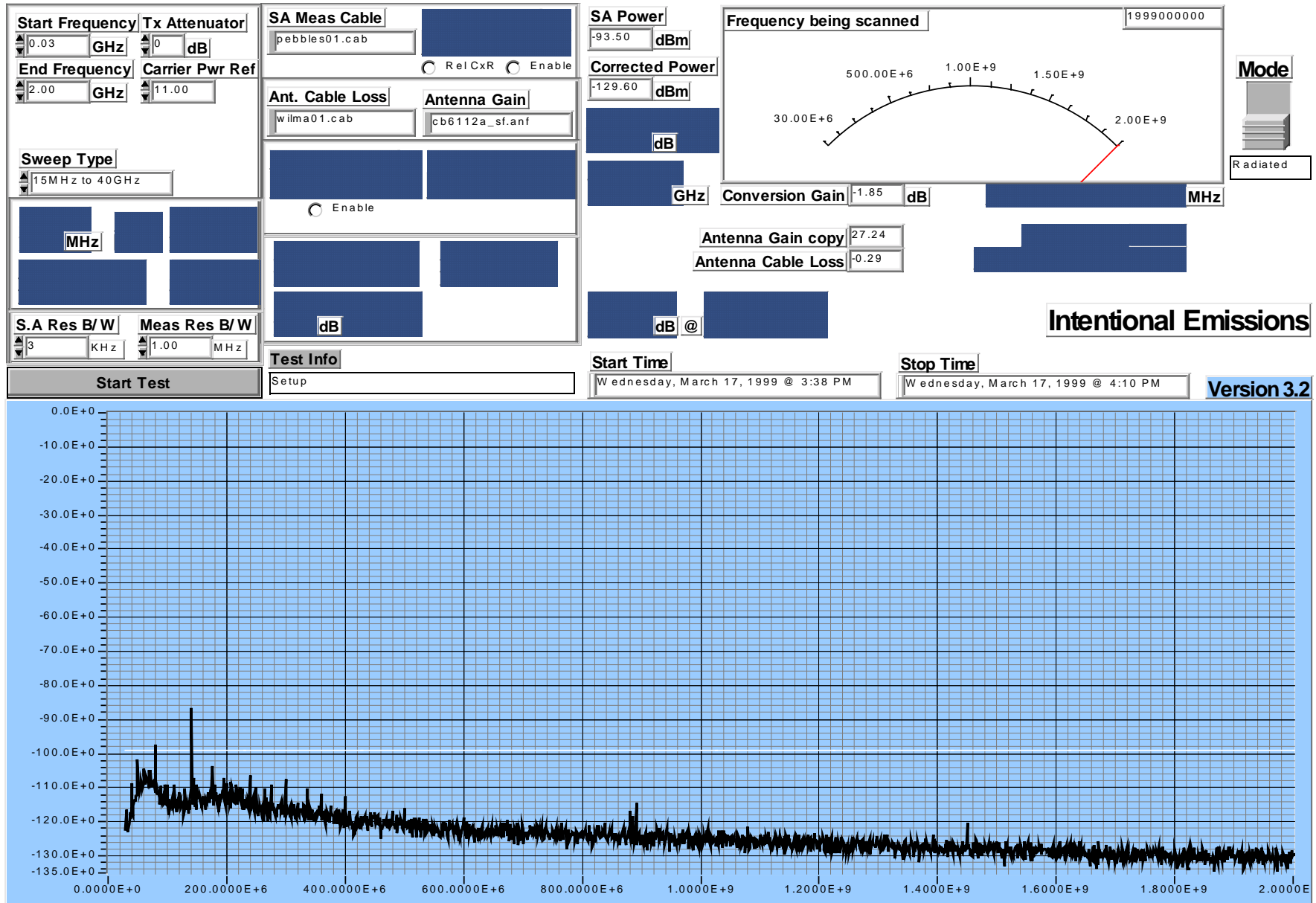

CTR 2800, 2 carrier QAM 64 modulated. – 30MHz to 2GHz – Vertical

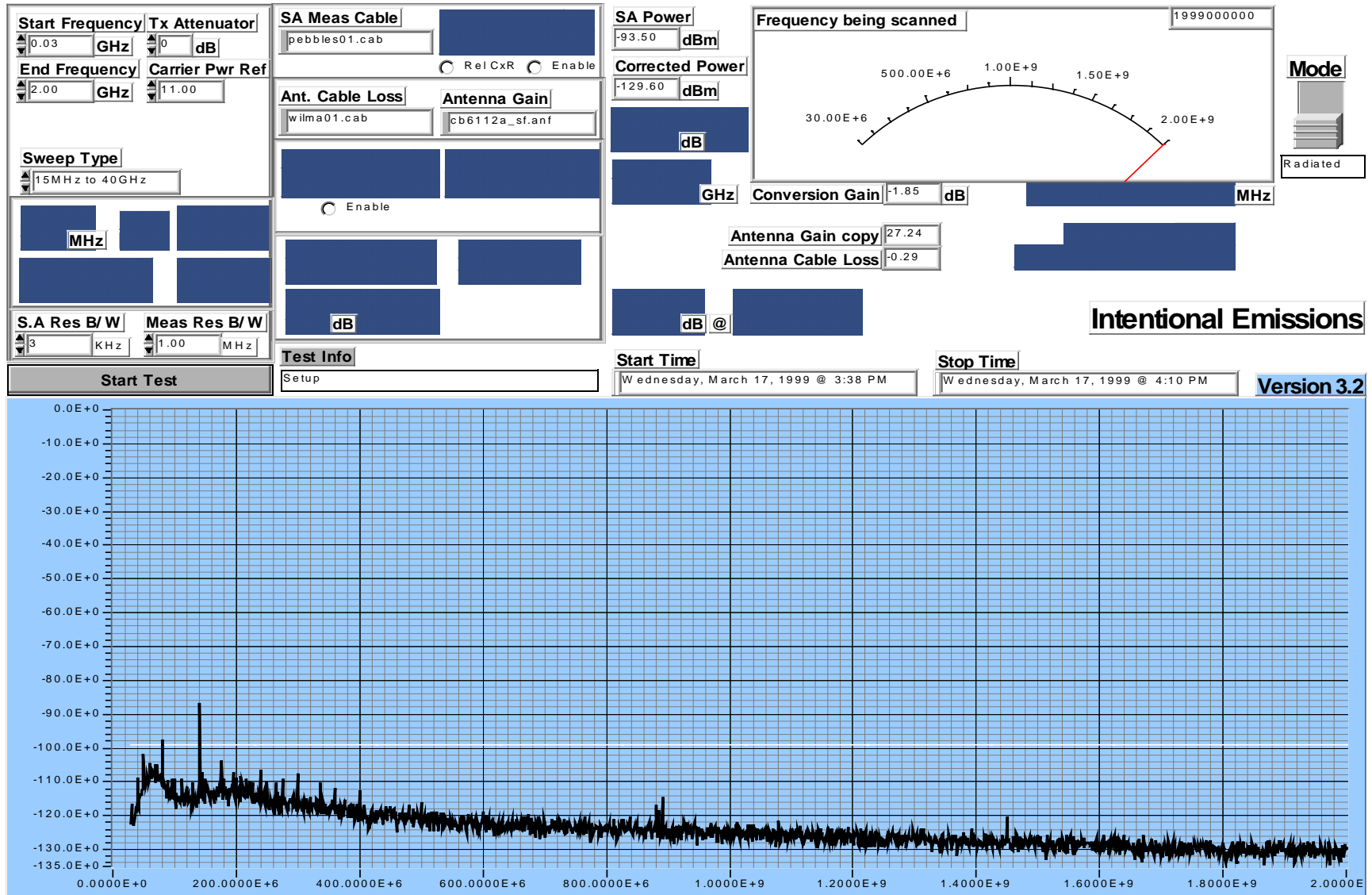

CTR 2800, 2 carrier QAM 64 modulated. – 1GHz to 18GHz - Horizontal

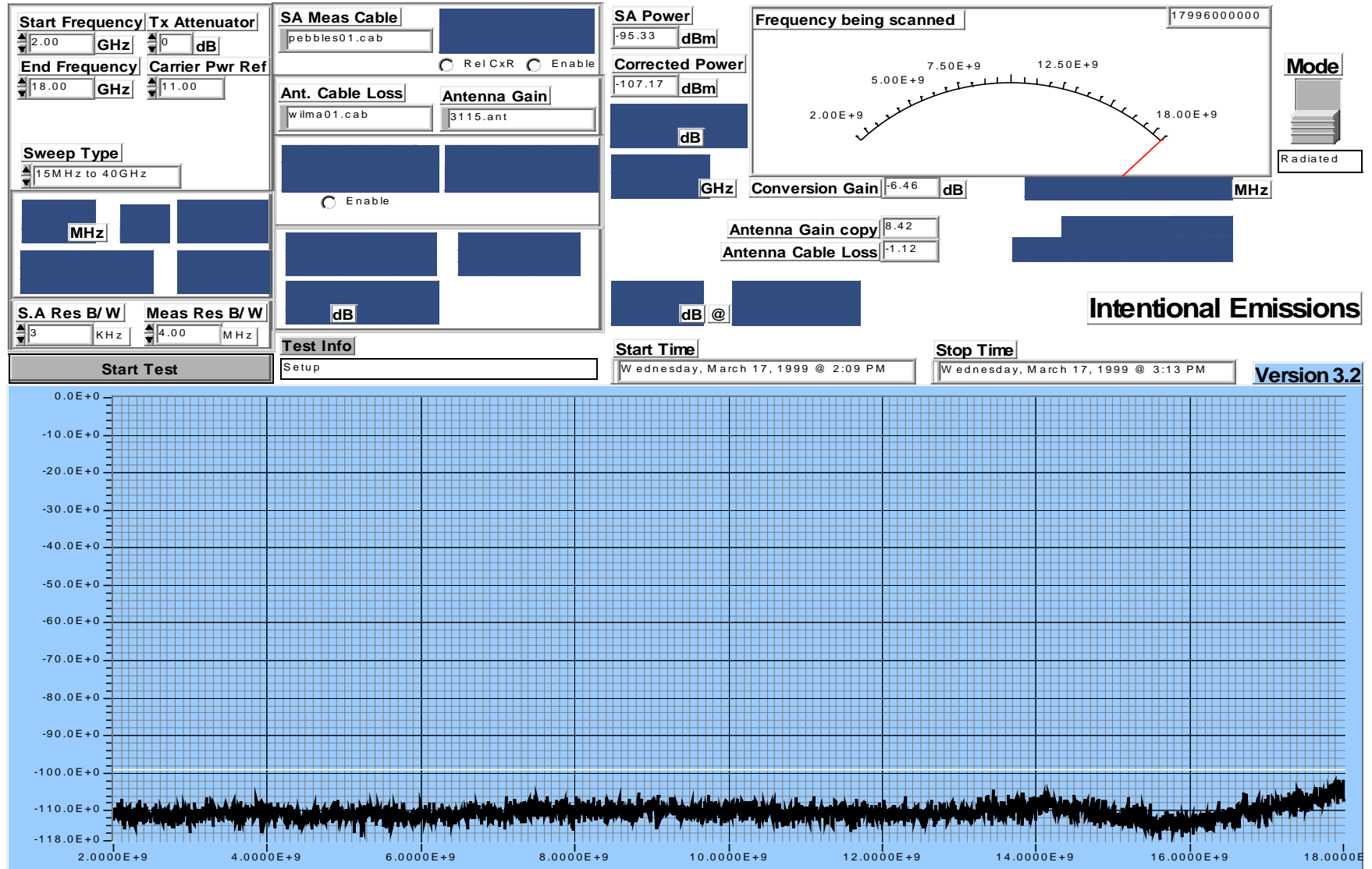

CTR 2800, 2 carrier QAM 64 modulated. – 1GHz to 18GHz - Vertical

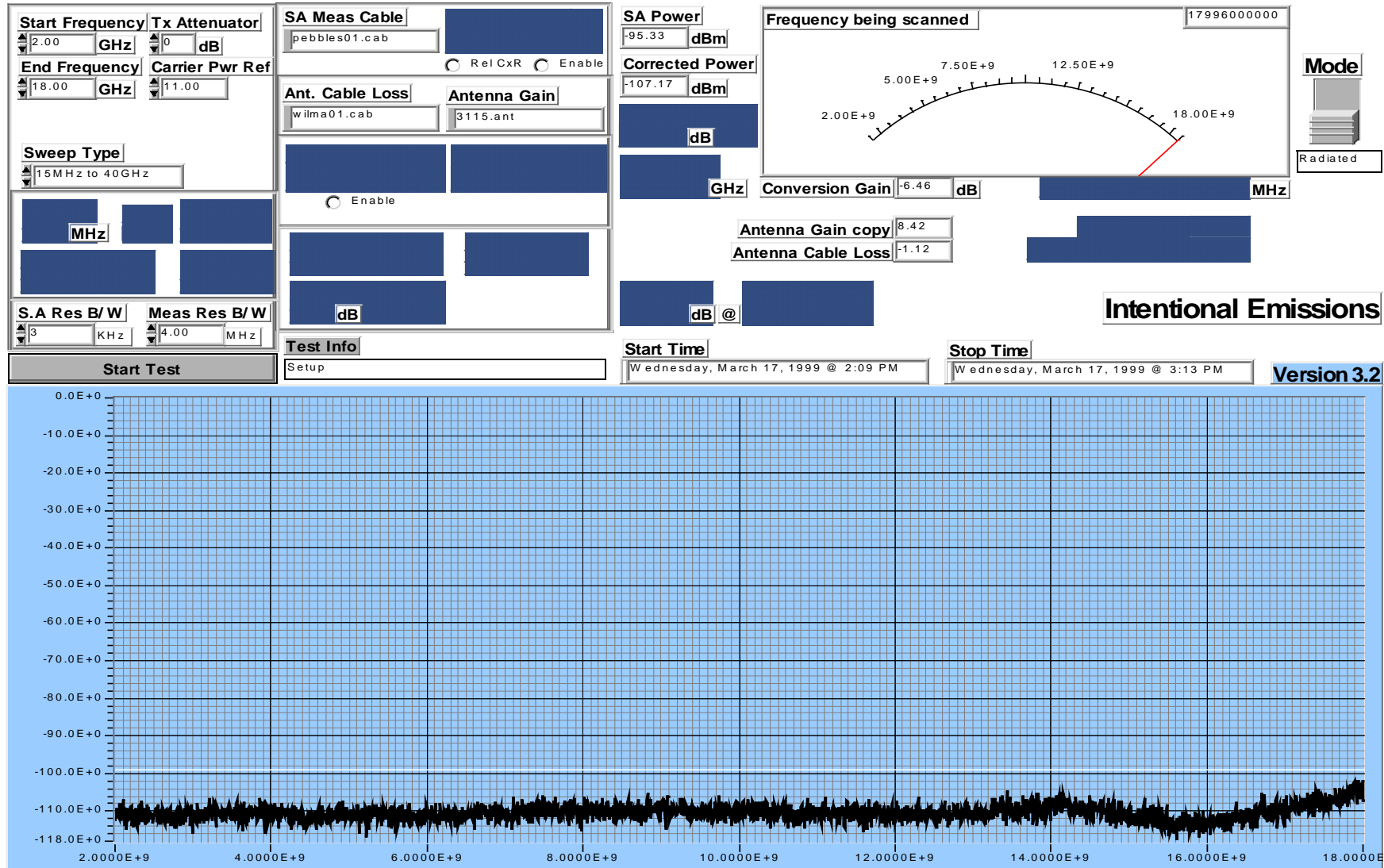

CTR 2800, 2 carrier QAM 64 modulated. -18GHz to 40GHz - Horizontal

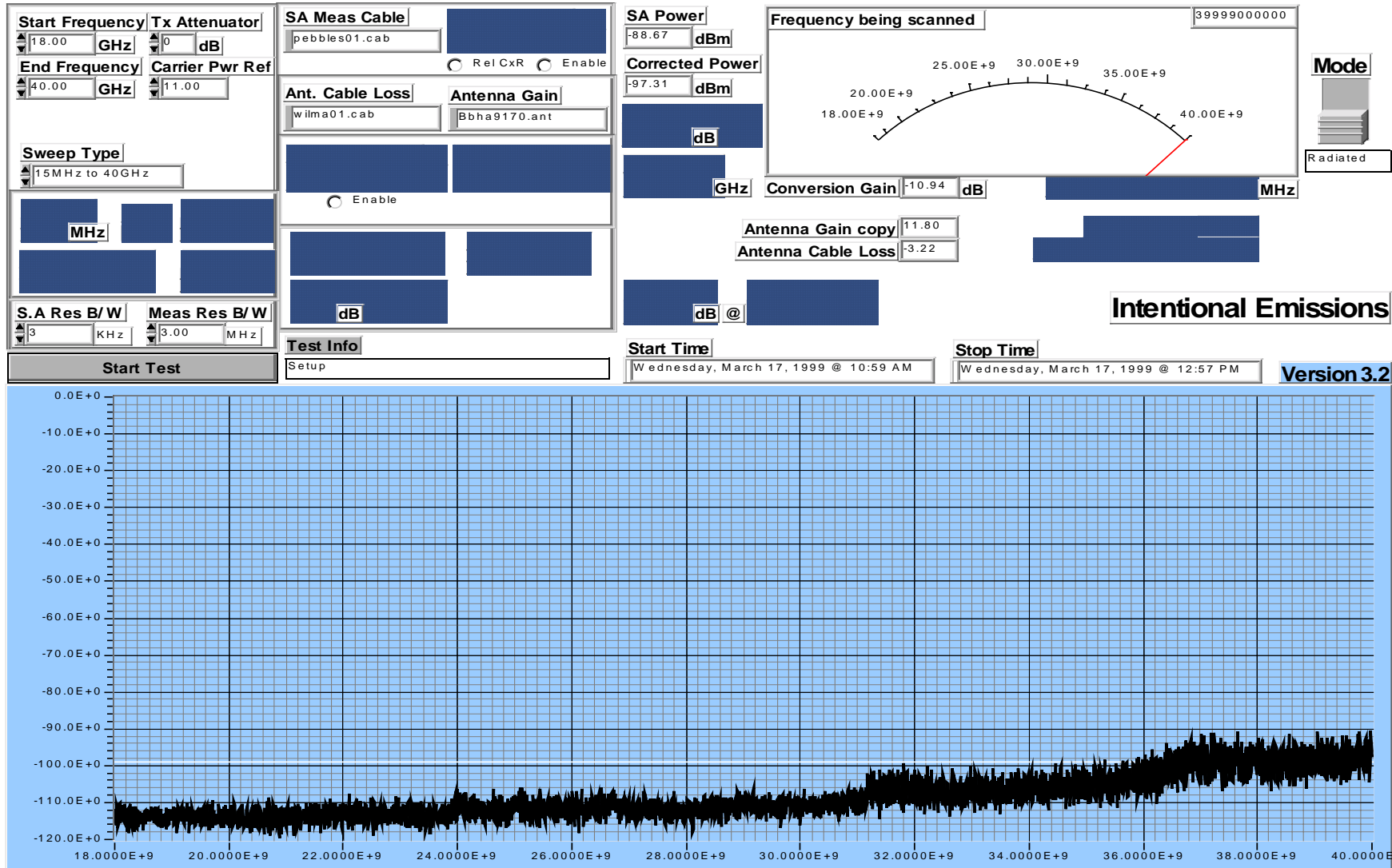

CTR 2800, 2 carrier QAM 64 modulated. -18GHz to 40GHz - Vertical

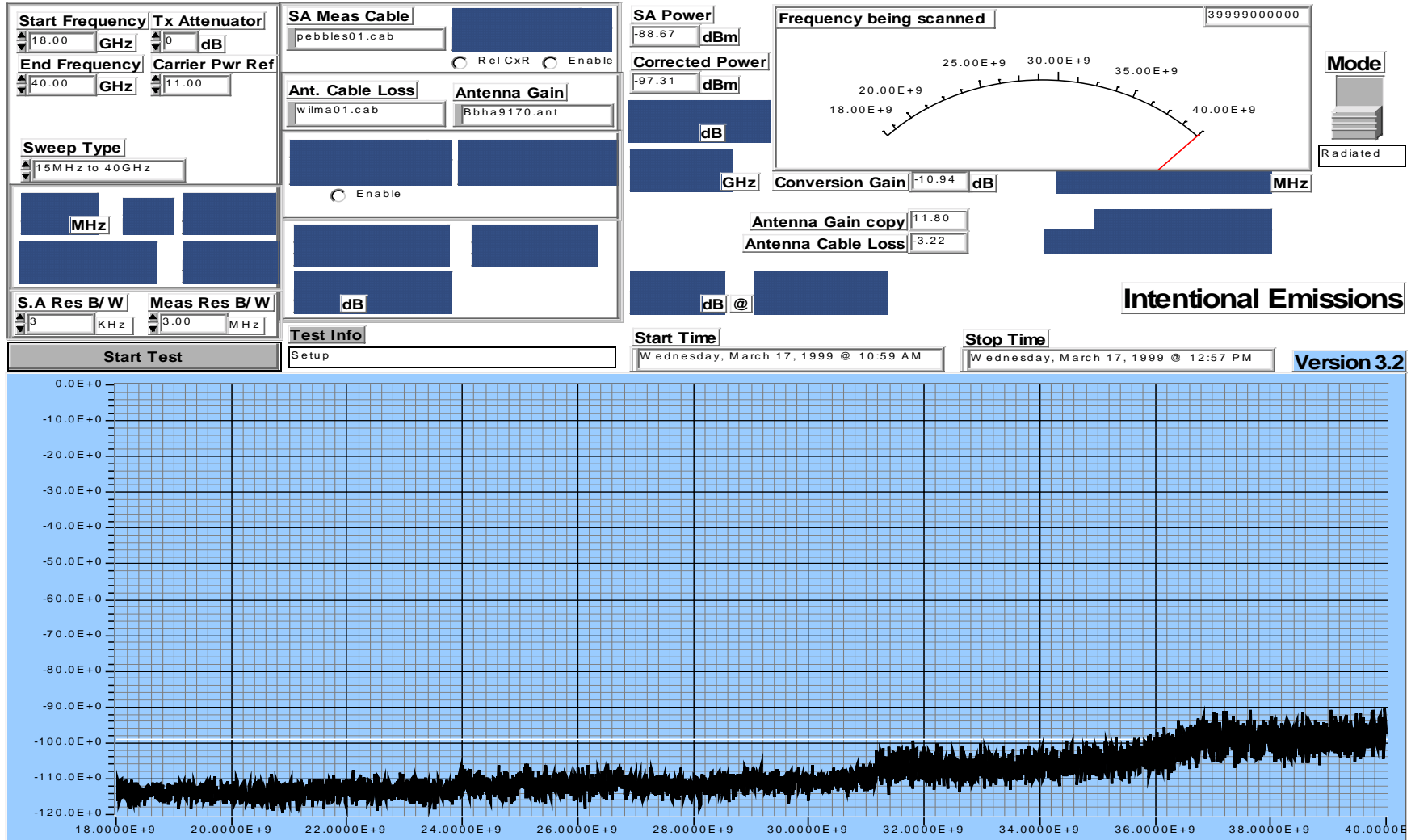

CTR 2800, 2 carrier QAM 64 modulated. -40GHz to 60GHz - Horizontal

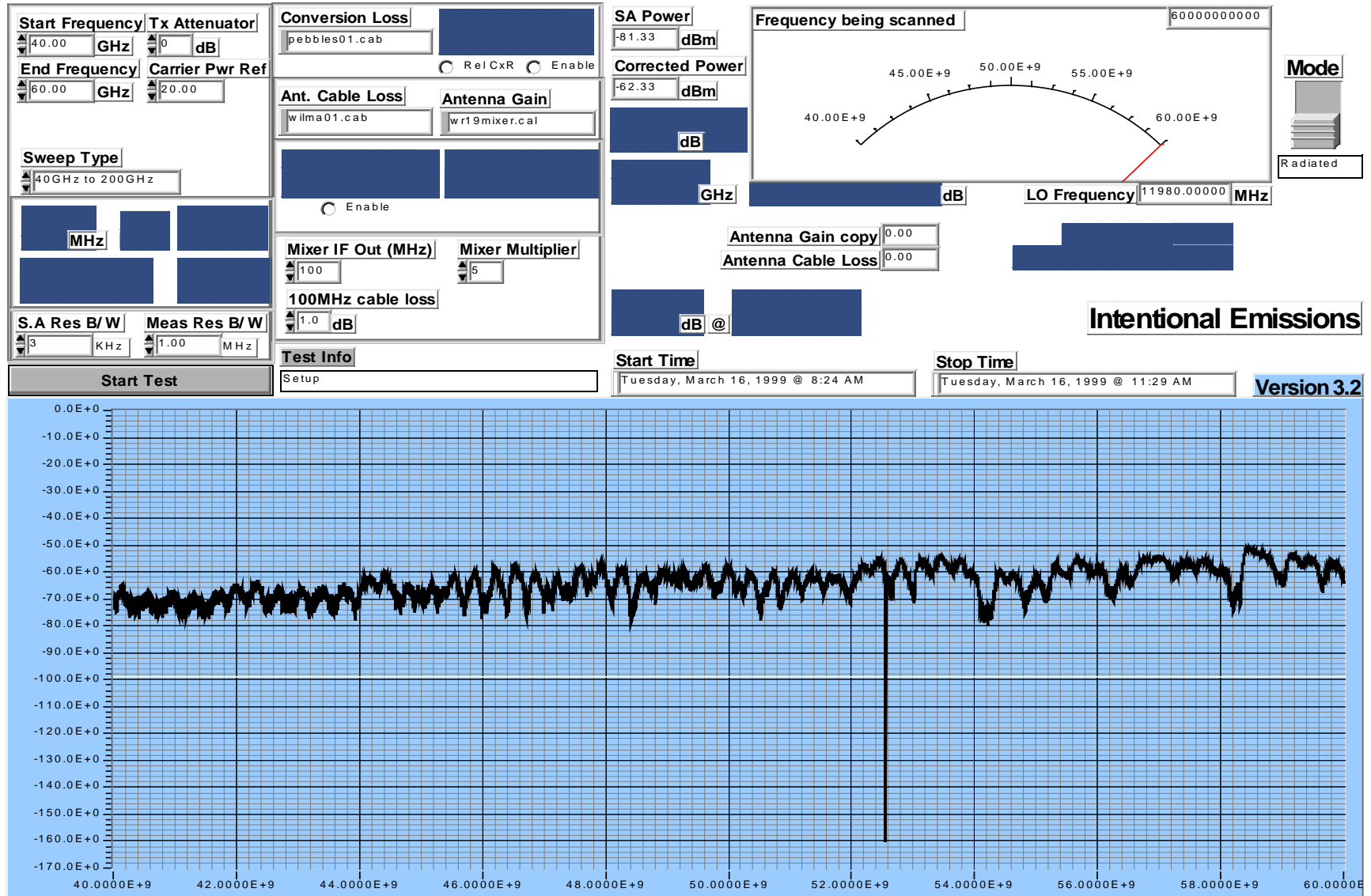

CTR 2800, 2 carrier QAM 64 modulated. -40GHz to 60GHz - Vertical

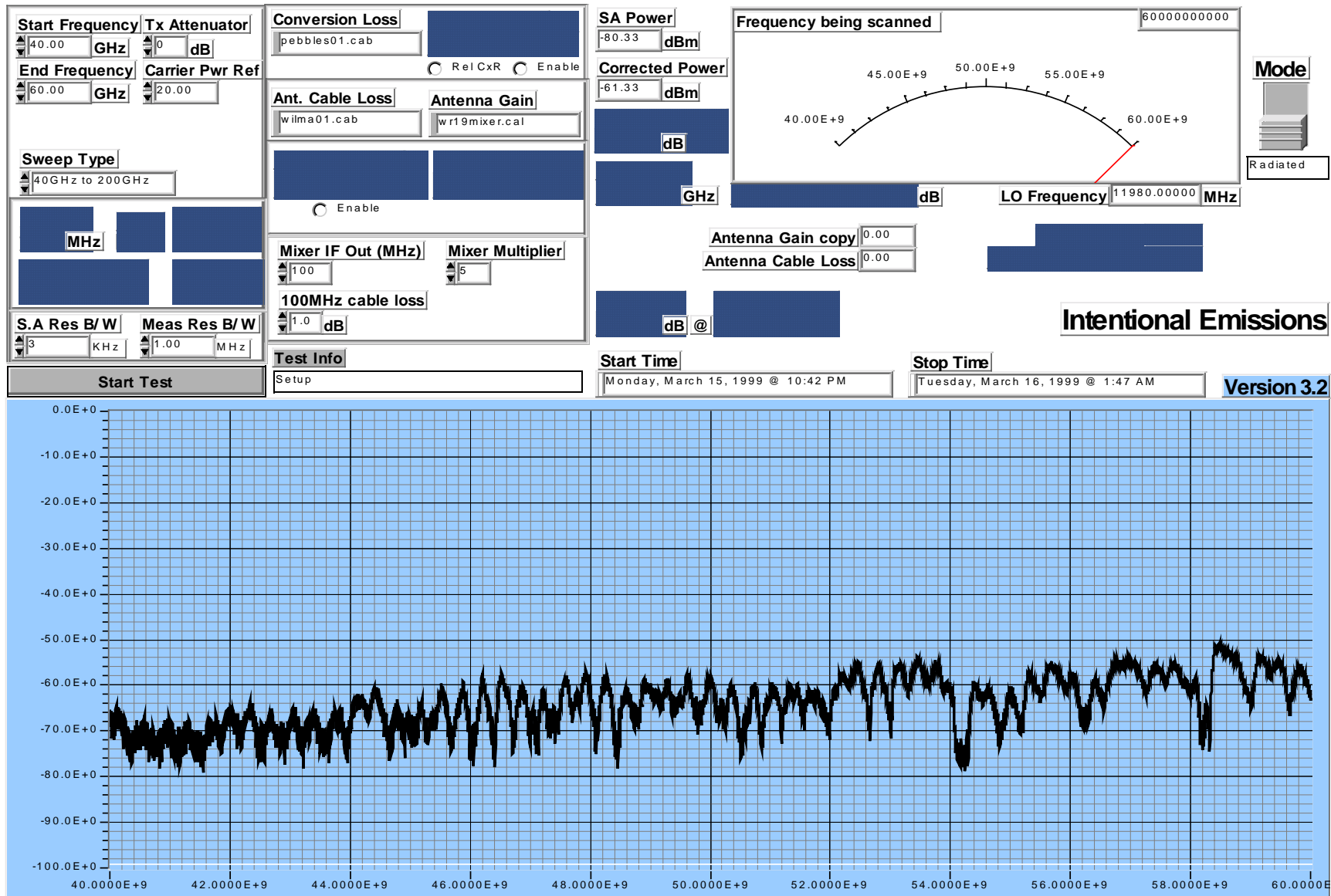

CTR 2800, 2 carrier QAM 64 modulated. -60GHz to 90GHz - Horizontal

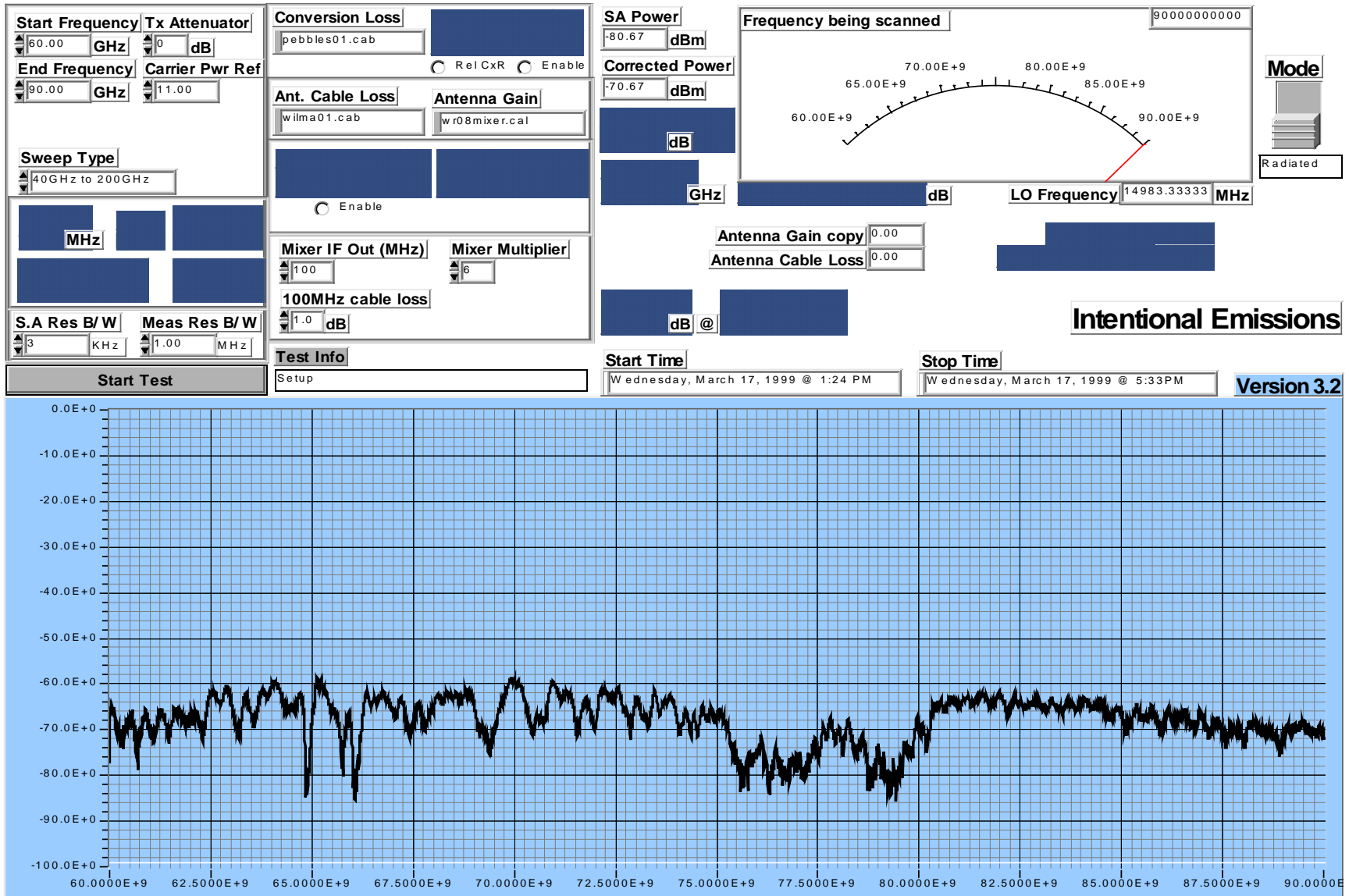

CTR 2800, 2 carrier QAM 64 modulated. -60GHz to 90GHz - Vertical

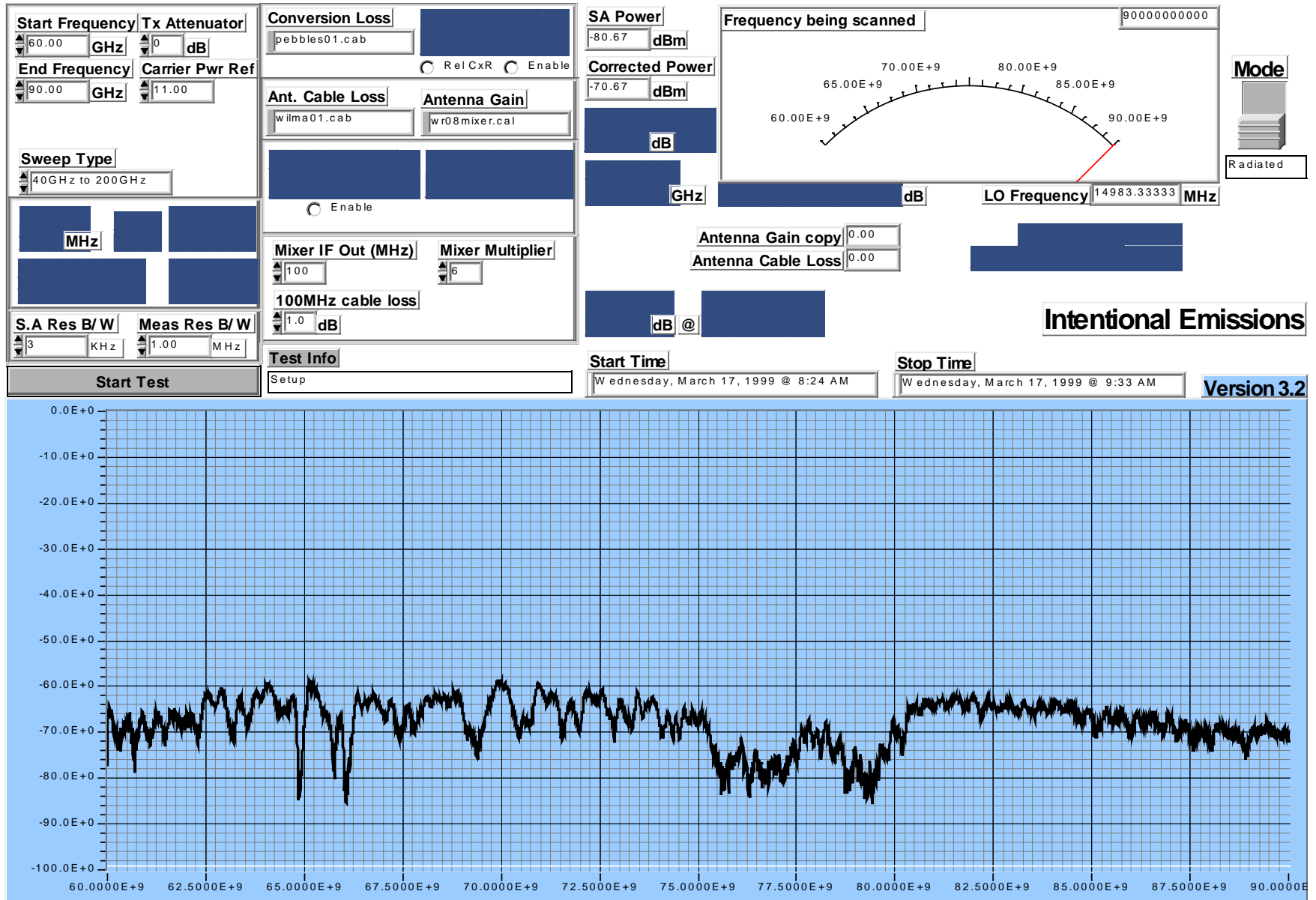

CTR 2800, 2 carrier QAM 64 modulated. -90GHz to 140GHz - Horizontal

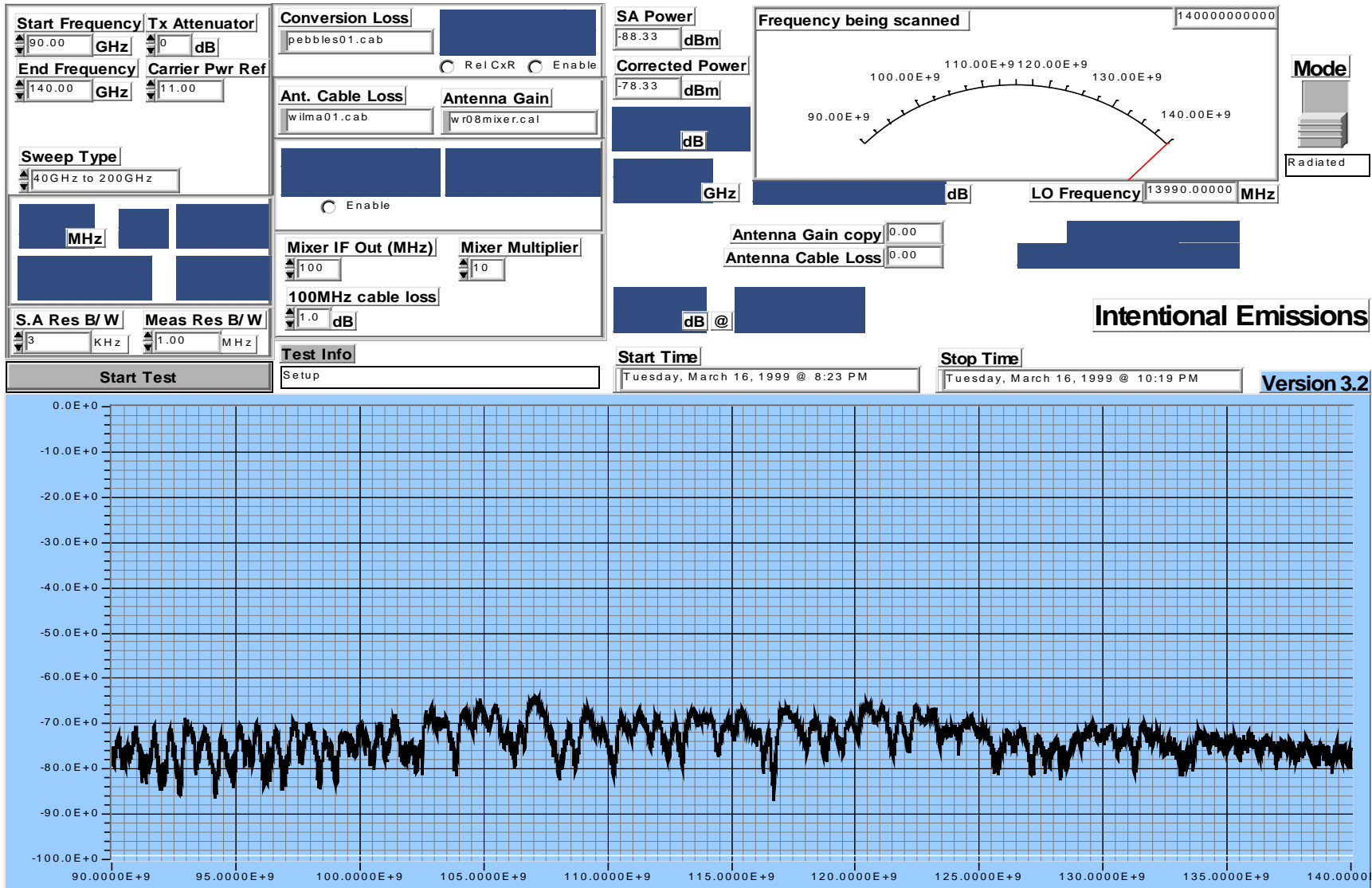

CTR 2800, 2 carrier QAM 64 modulated. -90GHz to 140GHz - Vertical

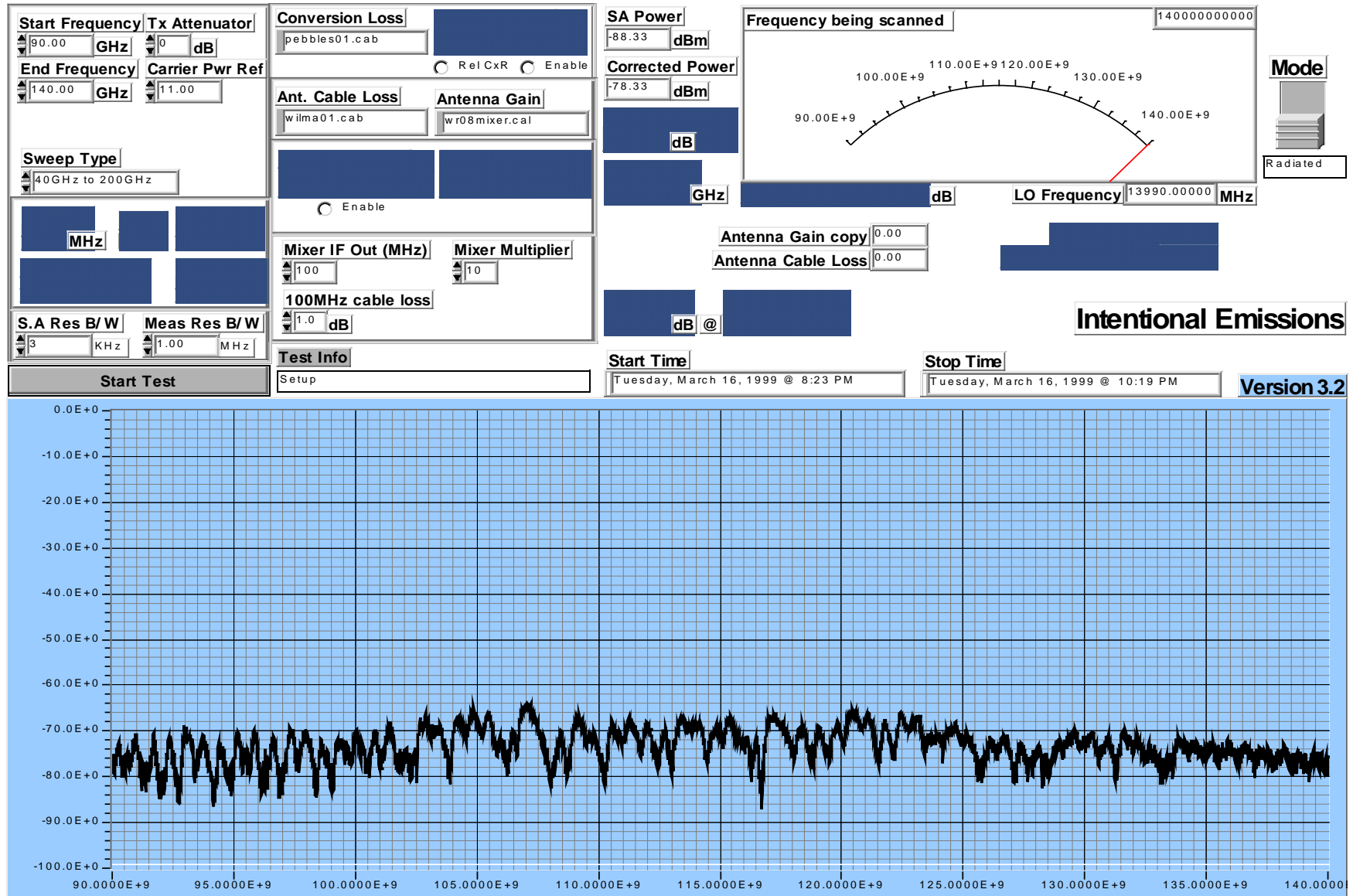

APPENDIX C

Temperature Stability Measurements Results

TEMPERATURE STABILITY MEASUREMENTS RESULTS

Frequency Stability Test Setup



BTR Frequency Stability

Test Started @ Mon, Mar 08, 1999 @ 5:58 PM
Time elapsed 0 days, 10 hours and 48 minutes
Test Ended @ Mon, Mar 08, 1999 @ 11:07 PM

Frequency 29099.978538 GHz
Measured Temp 60.00
Temp Setpoint 60.00

Rev 1.2

Enable Power Switch

Templates
 Manual Entry

Thermocouples
 #1 #2 #3 #4 #5 #6

Test Duration Iterations?
 days: 0 hours: 0 minutes: 1 **Start**

Data Filename: c:\tbtr2807

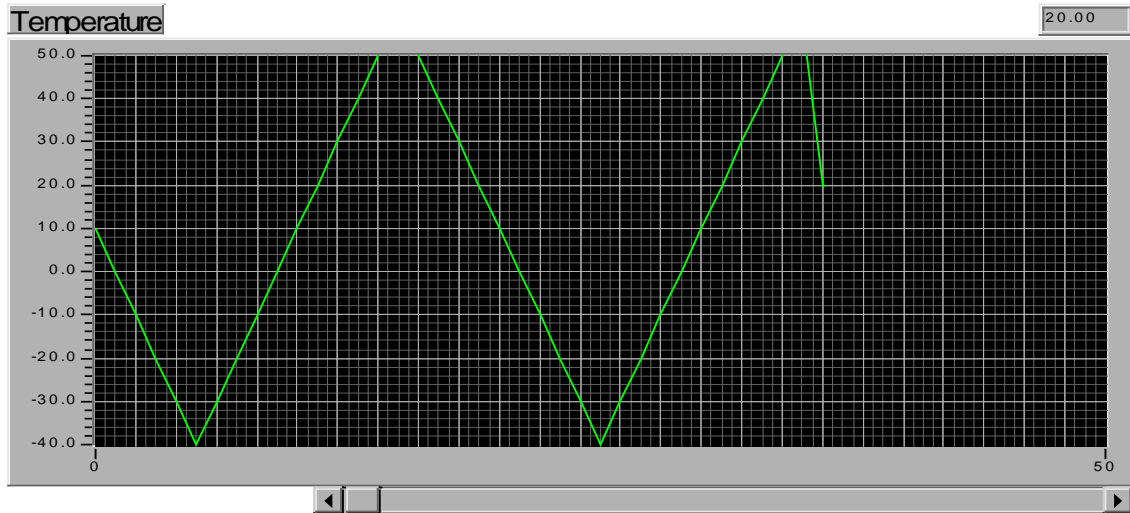
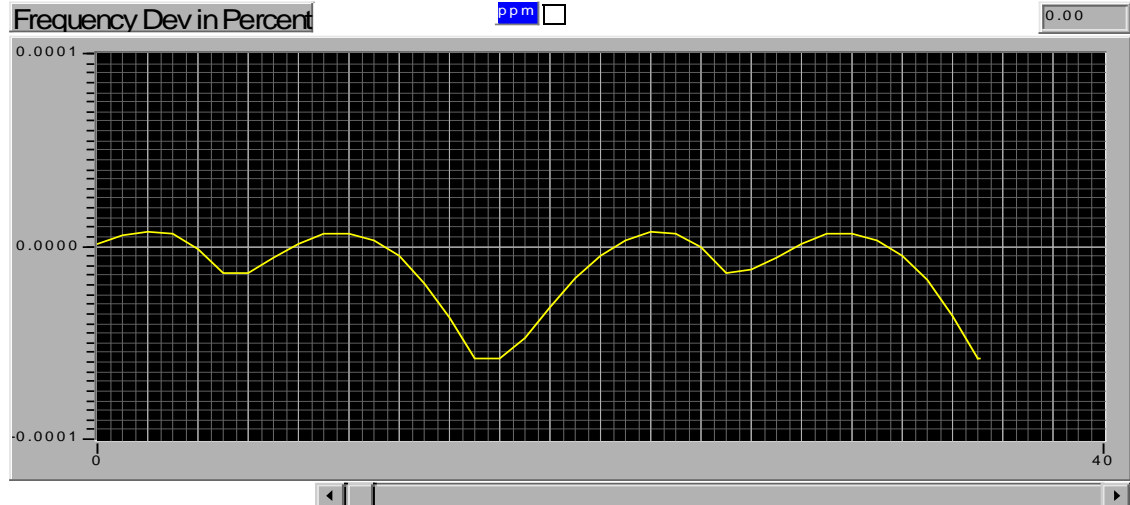

Reference Centre Frequency (MHz) 29099.995463
Test Status Finished

Date and Time			Frequency	Temp	Deviation
Mon	Mar08	1999 @ 6:16PM	29099.995747	10.0	0.000001
Mon	Mar08	1999 @ 6:36PM	29099.997153	0.0	0.000006
Mon	Mar08	1999 @ 6:54PM	29099.997590	-10.0	0.000007
Mon	Mar08	1999 @ 7:13PM	29099.997346	-20.0	0.000006
Mon	Mar08	1999 @ 7:32PM	29099.995199	-30.0	-0.000001
Mon	Mar08	1999 @ 7:51PM	29099.991453	-40.0	-0.000014
Mon	Mar08	1999 @ 8:10PM	29099.991398	-30.0	-0.000014
Mon	Mar08	1999 @ 8:27PM	29099.993856	-20.0	-0.000006
Mon	Mar08	1999 @ 8:44PM	29099.995924	-10.0	0.000002
Mon	Mar08	1999 @ 9:00PM	29099.997276	0.0	0.000006
Mon	Mar08	1999 @ 9:17PM	29099.997357	10.0	0.000007
Mon	Mar08	1999 @ 9:34PM	29099.996241	20.0	0.000003
Mon	Mar08	1999 @ 9:51PM	29099.993925	30.0	-0.000005
Mon	Mar08	1999 @ 10:09PM	29099.989839	40.0	-0.000019
Mon	Mar08	1999 @ 10:28PM	29099.984737	50.0	-0.000037
Mon	Mar08	1999 @ 10:48PM	29099.978462	60.0	-0.000058
Mon	Mar08	1999 @ 11:07PM	29099.978409	50.0	-0.000059
Mon	Mar08	1999 @ 11:24PM	29099.981585	40.0	-0.000048
Mon	Mar08	1999 @ 11:41PM	29099.986225	30.0	-0.000032
Tue	Mar09	1999 @ 12:00AM	29099.990573	20.0	-0.000017
Tue	Mar09	1999 @ 12:19AM	29099.993987	10.0	-0.000005
Tue	Mar09	1999 @ 12:38AM	29099.996469	0.0	0.000003
Tue	Mar09	1999 @ 12:55AM	29099.997603	-10.0	0.000007
Tue	Mar09	1999 @ 1:16AM	29099.997368	-20.0	0.000007
Tue	Mar09	1999 @ 1:34AM	29099.995438	-30.0	0.000000
Tue	Mar09	1999 @ 1:53AM	29099.991581	-40.0	-0.000013
Tue	Mar09	1999 @ 2:11AM	29099.992010	-30.0	-0.000012
Tue	Mar09	1999 @ 2:28AM	29099.993853	-20.0	-0.000006
Tue	Mar09	1999 @ 2:45AM	29099.995944	-10.0	0.000002
Tue	Mar09	1999 @ 3:01AM	29099.997295	0.0	0.000006
Tue	Mar09	1999 @ 3:18AM	29099.997420	10.0	0.000007
Tue	Mar09	1999 @ 3:35AM	29099.996299	20.0	0.000003
Tue	Mar09	1999 @ 3:52AM	29099.994005	30.0	-0.000005
Tue	Mar09	1999 @ 4:10AM	29099.990394	40.0	-0.000017
Tue	Mar09	1999 @ 4:27AM	29099.985010	50.0	-0.000036
Tue	Mar09	1999 @ 4:46AM	29099.978538	60.0	-0.000058

CTR Frequency Stability

Test Started @ Sat, Mar 06, 1999 @ 2:36 PM
Time elapsed 0 days, 7 hours and 10 minutes
Test Ended @ Sat, Mar 06, 1999 @ 6:04 PM

Frequency 28349.976123 GHz
Measured Temp 50.00
Temp Setpoint 50.00

Rev 1.2

Enable Power Switch

Templates
 Manual Entry

Thermocouples
 #1 #2 #3 #4 #5 #6

Test Duration Iterations?
 days: 0 hours: 0 minutes: 1 **Start**

Data Filename c:\CTR28-07

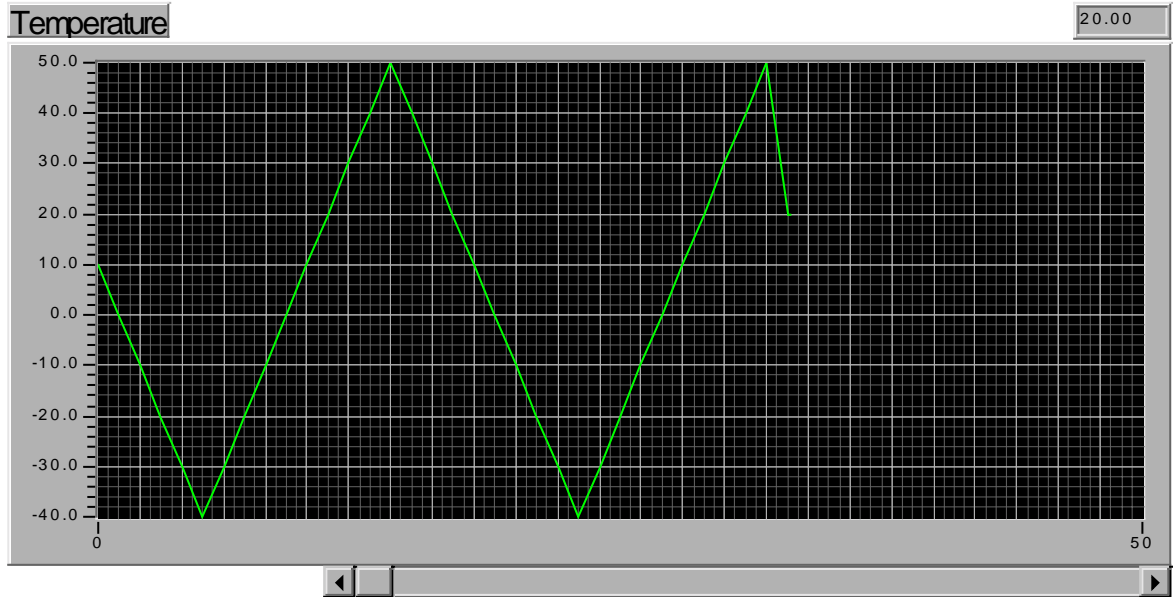
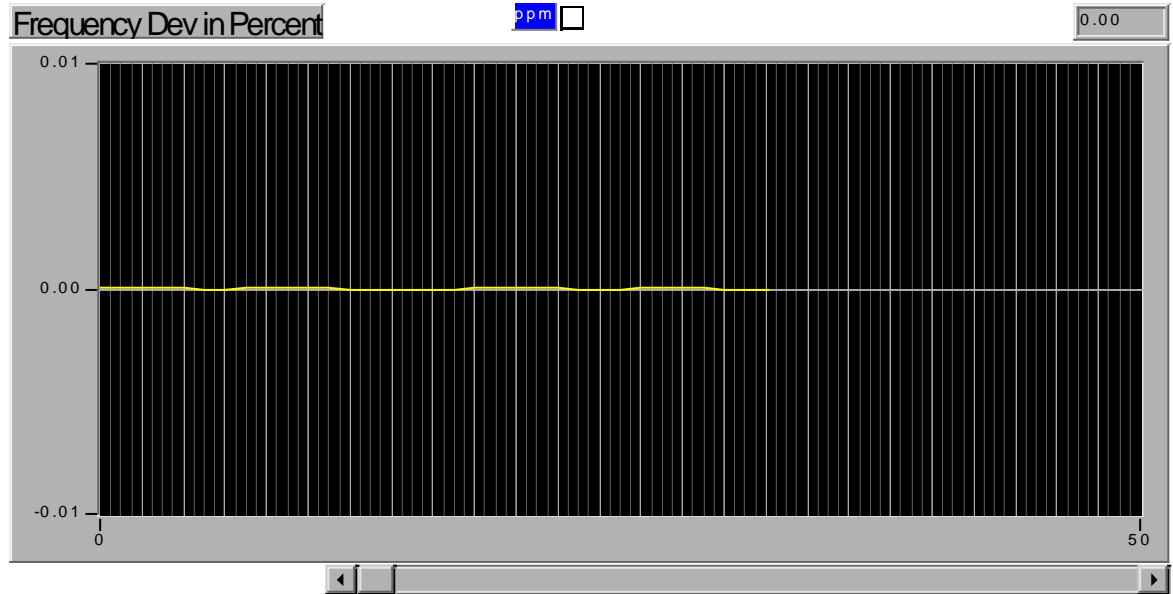

Reference Centre Frequency (MHz) 28349.981227

Test Status Finished

Date and Time			Frequency	Temp	Deviation
Sat	Mar 06	1999 @ 2:47 PM	28349.982318	10.0	0.000004
Sat	Mar 06	1999 @ 2:59 PM	28349.983326	0.0	0.000007
Sat	Mar 06	1999 @ 3:13 PM	28349.983705	-10.0	0.000009
Sat	Mar 06	1999 @ 3:27 PM	28349.983266	-20.0	0.000007
Sat	Mar 06	1999 @ 3:41 PM	28349.982303	-30.0	0.000004
Sat	Mar 06	1999 @ 3:55 PM	28349.979945	-40.0	-0.000005
Sat	Mar 06	1999 @ 4:09 PM	28349.979937	-30.0	-0.000005
Sat	Mar 06	1999 @ 4:20 PM	28349.981277	-20.0	0.000000
Sat	Mar 06	1999 @ 4:32 PM	28349.982322	-10.0	0.000004
Sat	Mar 06	1999 @ 4:44 PM	28349.982972	0.0	0.000006
Sat	Mar 06	1999 @ 4:56 PM	28349.983086	10.0	0.000007
Sat	Mar 06	1999 @ 5:08 PM	28349.982624	20.0	0.000005
Sat	Mar 06	1999 @ 5:20 PM	28349.981028	30.0	-0.000001
Sat	Mar 06	1999 @ 5:35 PM	28349.978784	40.0	-0.000009
Sat	Mar 06	1999 @ 5:49 PM	28349.975842	50.0	-0.000019
Sat	Mar 06	1999 @ 6:04 PM	28349.976447	40.0	-0.000017
Sat	Mar 06	1999 @ 6:16 PM	28349.978139	30.0	-0.000011
Sat	Mar 06	1999 @ 6:28 PM	28349.980213	20.0	-0.000004
Sat	Mar 06	1999 @ 6:42 PM	28349.982028	10.0	0.000003
Sat	Mar 06	1999 @ 6:56 PM	28349.983258	0.0	0.000007
Sat	Mar 06	1999 @ 7:10 PM	28349.983670	-10.0	0.000009
Sat	Mar 06	1999 @ 7:24 PM	28349.983325	-20.0	0.000007
Sat	Mar 06	1999 @ 7:38 PM	28349.982134	-30.0	0.000003
Sat	Mar 06	1999 @ 7:52 PM	28349.979825	-40.0	-0.000005
Sat	Mar 06	1999 @ 8:06 PM	28349.980026	-30.0	-0.000004
Sat	Mar 06	1999 @ 8:18 PM	28349.981167	-20.0	-0.000000
Sat	Mar 06	1999 @ 8:30 PM	28349.982257	-10.0	0.000004
Sat	Mar 06	1999 @ 8:41 PM	28349.982956	0.0	0.000006
Sat	Mar 06	1999 @ 8:53 PM	28349.983092	10.0	0.000007
Sat	Mar 06	1999 @ 9:06 PM	28349.982394	20.0	0.000004
Sat	Mar 06	1999 @ 9:20 PM	28349.981157	30.0	-0.000000
Sat	Mar 06	1999 @ 9:32 PM	28349.978976	40.0	-0.000008
Sat	Mar 06	1999 @ 9:47 PM	28349.976123	50.0	-0.000018

APPENDIX D

SPECTRAL MASK LIMIT CALCULATIONS

Symbol rate (Msps)	8	Center Freq. (MHz) 29116.2 BTR - low side mask		
Authorized BW (MHz)	40			
O/P Channel Power (dBm)	20	0.1	Watts	
% Removed	FCC Spec	Delta BW	Lwr Band	Upr Band
0	0	0	29116.2	29116.2
50	0	20	29096.2	29136.2
50.5	-27.2205999	20.2	29096	29136.4
51	-27.4205999	20.4	29095.8	29136.6
55	-29.0205999	22	29094.2	29138.2
60	-31.0205999	24	29092.2	29140.2
75	-37.0205999	30	29086.2	29146.2
100	-47.0205999	40	29076.2	29156.2
101	-47.4205999	40.4	29075.8	29156.6
102	-47.8205999	40.8	29075.4	29157
105	-49.0205999	42	29074.2	29158.2
106	-49.4205999	42.4	29073.8	29158.6
107	-49.8205999	42.8	29073.4	29159
107.45	-50.0005999	42.98	29073.22	29159.18
115	-53.0205999	46	29070.2	29162.2
120	-55.0205999	48	29068.2	29164.2
125	-56	50	29066.2	29166.2
150	-56	60	29056.2	29176.2
175	-56	70	29046.2	29186.2
200	-56	80	29036.2	29196.2
250	-56	100	29016.2	29216.2
250.1	-43	100.04	29016.16	29216.24
300	-43	120	28996.2	29236.2
500	-43	200	28916.2	29316.2
1000	-43	400	28716.2	29516.2
1100	-43	440	28676.2	29556.2
1200	-43	500	28616.2	29616.2
1250	-43	500	28616.2	29616.2
1300	-43	520	28596.2	29636.2
1500	-43	600	28516.2	29716.2
Number of CXR	4	Center Freq (MHz) 29181.2 BTR - mid-band mask		

Symbol rate (Msps)	8			
Authorized BW (MHz)	40			
O/P Channel Power (dBm)	20	0.1	Watts	
% Removed	FCC Spec	Delta BW	Lower Band	Upper Band
0	0	0	29181.2	29181.2
50	0	20	29161.2	29201.2
50.5	-27.2205999	20.2	29161	29201.4
51	-27.4205999	20.4	29160.8	29201.6
55	-29.0205999	22	29159.2	29203.2
60	-31.0205999	24	29157.2	29205.2
75	-37.0205999	30	29151.2	29211.2
100	-47.0205999	40	29141.2	29221.2
101	-47.4205999	40.4	29140.8	29221.6
102	-47.8205999	40.8	29140.4	29222
105	-49.0205999	42	29139.2	29223.2
106	-49.4205999	42.4	29138.8	29223.6
107	-49.8205999	42.8	29138.4	29224
107.45	-50.0005999	42.98	29138.22	29224.18
115	-53.0205999	46	29135.2	29227.2
120	-55.0205999	48	29133.2	29229.2
125	-56	50	29131.2	29231.2
150	-56	60	29121.2	29241.2
175	-56	70	29111.2	29251.2
200	-56	80	29101.2	29261.2
250	-56	100	29081.2	29281.2
250.1	-43	100.04	29081.16	29281.24
300	-43	120	29061.2	29301.2
500	-43	200	28981.2	29381.2
1000	-43	400	28781.2	29581.2
1100	-43	440	28741.2	29621.2
1200	-43	500	28681.2	29681.2
1250	-43	500	28681.2	29681.2
1300	-43	520	28661.2	29701.2
1500	-43	600	28581.2	29781.2
Number of CXR	4	Center Freq. (MHz)	29236.6	BTR - high-band mask
Symbol rate (Msps)	8			

Authorized BW (MHz)	40			
O/P Channel Power (dBm)	20	0.1	Watts	
% Removed	FCC Spec	Delta BW	Lower Band	Upper Band
0	0	0	29236.6	29236.6
50	0	20	29216.6	29256.6
50.5	-27.2205999	20.2	29216.4	29256.8
51	-27.4205999	20.4	29216.2	29257
55	-29.0205999	22	29214.6	29258.6
60	-31.0205999	24	29212.6	29260.6
75	-37.0205999	30	29206.6	29266.6
100	-47.0205999	40	29196.6	29276.6
101	-47.4205999	40.4	29196.2	29277
102	-47.8205999	40.8	29195.8	29277.4
105	-49.0205999	42	29194.6	29278.6
106	-49.4205999	42.4	29194.2	29279
107	-49.8205999	42.8	29193.8	29279.4
107.45	-50.0005999	42.98	29193.62	29279.58
115	-53.0205999	46	29190.6	29282.6
120	-55.0205999	48	29188.6	29284.6
125	-56	50	29186.6	29286.6
150	-56	60	29176.6	29296.6
175	-56	70	29166.6	29306.6
200	-56	80	29156.6	29316.6
250	-56	100	29136.6	29336.6
250.1	-43	100.04	29136.56	29336.64
300	-43	120	29116.6	29356.6
500	-43	200	29036.6	29436.6
1000	-43	400	28836.6	29636.6
1100	-43	440	28796.6	29676.6
1200	-43	500	28736.6	29736.6
1250	-43	500	28736.6	29736.6
1300	-43	520	28716.6	29756.6
1500	-43	600	28636.6	29836.6
Number of CXR	2	Center Freq. (MHz)	28206.1	CTR - low side mask
Symbol rate (Msps)	8			
Authorized BW (MHz)	20			

O/P Channel Power (dBm)	20	0.1	Watts	
% Removed	FCC Spec	Delta BW	Lower Band	Upper Band
0	0	0	28205	28205
50	0	10	28195	28215
50.5	-24.2103	10.1	28194.9	28215.1
51	-24.4103	10.2	28194.8	28215.2
55	-26.0103	11	28194	28216
60	-28.0103	12	28193	28217
75	-34.0103	15	28190	28220
100	-44.0103	20	28185	28225
101	-44.4103	20.2	28184.8	28225.2
102	-44.8103	20.4	28184.6	28225.4
105	-46.0103	21	28184	28226
106	-46.4103	21.2	28183.8	28226.2
107	-46.8103	21.4	28183.6	28226.4
107.45	-46.9903	21.49	28183.51	28226.49
115	-50.0103	23	28182	28228
120	-52.0103	24	28181	28229
125	-56	25	28180	28230
150	-56	30	28175	28235
175	-56	35	28170	28240
200	-56	40	28165	28245
250	-56	50	28155	28255
250.1	-43	50.02	28154.98	28255.02
300	-43	60	28145	28265
500	-43	100	28105	28305
1000	-43	200	28005	28405
1100	-43	440	27765	28645
1200	-43	250	27955	28455
1250	-43	250	27955	28455
1300	-43	260	27945	28465
1500	-43	300	27905	28505
Number of CXR	2	Center Freq. (MHz)	28345.2	CTR - midpoint mask
Symbol rate (Msps)	8			
Authorized BW (MHz)	20			
O/P Channel Power (dBm)	20			
		0.1	Watts	

% Removed	FCC Spec	Delta BW	Lower Band	Upper Band
0	0	0	28345.2	28345.2
50	0	10	28335.2	28355.2
50.5	-24.2103	10.1	28335.1	28355.3
51	-24.4103	10.2	28335	28355.4
55	-26.0103	11	28334.2	28356.2
60	-28.0103	12	28333.2	28357.2
75	-34.0103	15	28330.2	28360.2
100	-44.0103	20	28325.2	28365.2
101	-44.4103	20.2	28325	28365.4
102	-44.8103	20.4	28324.8	28365.6
105	-46.0103	21	28324.2	28366.2
106	-46.4103	21.2	28324	28366.4
107	-46.8103	21.4	28323.8	28366.6
107.45	-46.9903	21.49	28323.71	28366.69
115	-50.0103	23	28322.2	28368.2
120	-52.0103	24	28321.2	28369.2
125	-56	25	28320.2	28370.2
150	-56	30	28315.2	28375.2
175	-56	35	28310.2	28380.2
200	-56	40	28305.2	28385.2
250	-56	50	28295.2	28395.2
250.1	-43	50.02	28295.18	28395.22
300	-43	60	28285.2	28405.2
500	-43	100	28245.2	28445.2
1000	-43	200	28145.2	28545.2
1100	-43	440	27905.2	28785.2
1200	-43	250	28095.2	28595.2
1250	-43	250	28095.2	28595.2
1300	-43	260	28085.2	28605.2
1500	-43	300	28045.2	28645.2
Number of CXR	2	Center Freq. (MHz)	28.2751	CTR - high side mask
Symbol rate (Msps)	8			
Authorized BW (MHz)	20			
O/P Channel Power (dBm)	20	0.1	Watts	
% Removed	FCC Spec	Delta BW	Lower Band	Upper Band

0	0	0	28275.1	28275.1
50	0	10	28265.1	28285.1
50.5	-24.2103	10.1	28265	28285.2
51	-24.4103	10.2	28264.9	28285.3
55	-26.0103	11	28264.1	28286.1
60	-28.0103	12	28263.1	28287.1
75	-34.0103	15	28260.1	28290.1
100	-44.0103	20	28255.1	28295.1
101	-44.4103	20.2	28254.9	28295.3
102	-44.8103	20.4	28254.7	28295.5
105	-46.0103	21	28254.1	28296.1
106	-46.4103	21.2	28253.9	28296.3
107	-46.8103	21.4	28253.7	28296.5
107.45	-46.9903	21.49	28253.61	28296.59
115	-50.0103	23	28252.1	28298.1
120	-52.0103	24	28251.1	28299.1
125	-56	25	28250.1	28300.1
150	-56	30	28245.1	28305.1
175	-56	35	28240.1	28310.1
200	-56	40	28235.1	28315.1
250	-56	50	28225.1	28325.1
250.1	-43	50.02	28225.08	28325.12
300	-43	60	28215.1	28335.1
500	-43	100	28175.1	28375.1
1000	-43	200	28075.1	28475.1
1100	-43	440	27835.1	28715.1
1200	-43	250	28025.1	28525.1
1250	-43	250	28025.1	28525.1
1300	-43	260	28015.1	28535.1