



FCC ID: OHBNECSIGN  
 Report No.: T180802D05-RP2

Page: 1 / 42  
 Rev.: 01

## RADIO TEST REPORT FCC 47 CFR PART 15 SUBPART C

<b>Test Standard</b>	<b>FCC Part 15.247</b>
<b>Product name</b>	<b>NEC-SIGN</b>
<b>Brand Name</b>	<b>AAEON</b>
<b>Model No.</b>	<b>xNEC-SIGNxxxxxxxxxxxxx (x can be 0-9, A-Z, a-z, "-", or blank)</b>
<b>Test Result</b>	<b>Pass</b>

The test Result was tested by Compliance Certification Services Inc. The test data, data evaluation, test procedures, and equipment configurations shown in this report were given in ANSI C63.10: 2013 and compliance standards.

The test results of this report relate only to the tested sample (EUT) identified in this report.

The test Report of full or partial shall not copy. Without written approval of Compliance Certification Services Inc.( Wugu Laboratory)

Approved by:

Tested by:

---

Sam Chuang  
 Manager

---

Jerry Chuang  
 Engineer

Unless otherwise stated the results shown in this test report refer only to the sample(s) tested and such sample(s) are retained for 90 days only.  
 除非另有說明，此報告結果僅對測試之樣品負責，同時此樣品僅保留90天。本報告未經本公司書面許可，不可部分複製。

This document is issued by the Company subject to its General Conditions of Service printed overleaf, available on request or accessible at [www.sgs.com/terms\\_and\\_conditions.htm](http://www.sgs.com/terms_and_conditions.htm) and for electronic format documents, subject to Terms and Conditions for Electronic Documents at [www.sgs.com/terms\\_e-document.htm](http://www.sgs.com/terms_e-document.htm). Attention is drawn to the limitation of liability, indemnification and jurisdiction issues defined therein. Any holder of this document is advised that information contained hereon reflects the Company's findings at the time of its intervention only and within the limits of Client's instructions, if any. The Company's sole responsibility is to its Client and this document does not exonerate parties to a transaction from exercising all their rights and obligations under the transaction documents. This document cannot be reproduced except in full, without prior written approval of the Company. Any unauthorized alteration, forgery or falsification of the content or appearance of this document is unlawful and offenders may be prosecuted to the fullest extent of the law.

**Revision History**

Rev.	Issue Date	Revisions	Effect Page	Revised By
00	October 1, 2018	Initial Issue	ALL	Doris Chu
01	October 30, 2018	1. Revised KDB description.	P.16, 19, 21, 23, 28	Allison Chen

## Table of contents

<b>1.</b>	<b>GENERAL INFORMATION .....</b>	<b>4</b>
1.1	<b>EUT INFORMATION .....</b>	4
1.2	<b>EUT CHANNEL INFORMATION .....</b>	5
1.3	<b>ANTENNA INFORMATION .....</b>	5
1.4	<b>MEASUREMENT UNCERTAINTY.....</b>	6
1.5	<b>FACILITIES AND TEST LOCATION .....</b>	6
1.6	<b>INSTRUMENT CALIBRATION .....</b>	7
1.7	<b>SUPPORT AND EUT ACCESSORIES EQUIPMENT .....</b>	8
1.8	<b>TEST METHODOLOGY AND APPLIED STANDARDS .....</b>	8
<b>2.</b>	<b>TEST SUMMERY .....</b>	<b>9</b>
<b>3.</b>	<b>DESCRIPTION OF TEST MODES.....</b>	<b>10</b>
3.1	<b>THE WORST MODE OF OPERATING CONDITION .....</b>	10
3.2	<b>THE WORST MODE OF MEASUREMENT .....</b>	11
3.3	<b>EUT DUTY CYCLE .....</b>	12
<b>4.</b>	<b>TEST RESULT .....</b>	<b>13</b>
4.1	<b>AC POWER LINE CONDUCTED EMISSION .....</b>	13
4.2	<b>6dB BANDWIDTH AND OCCUPIED BANDWIDTH(99%).....</b>	16
4.3	<b>OUTPUT POWER MEASUREMENT .....</b>	19
4.4	<b>POWER SPECTRAL DENSITY .....</b>	21
4.5	<b>CONDUCTED BAND EDGE AND SPURIOUS EMISSION .....</b>	23
4.6	<b>RADIATION BANDEDGE AND SPURIOUS EMISSION .....</b>	27
<b>APPENDIX 1 - PHOTOGRAPHS OF EUT</b>		

## 1. GENERAL INFORMATION

### 1.1 EUT INFORMATION

<b>Applicant</b>	AAEON Technology Inc. 5F, No.135, Lane 235, Pao Chiao Rd, Hsin-Tien Dist., New Taipei City, Taiwan, R.O.C
<b>Manufacturer</b>	AAEON Technology Inc. 5F, No.135, Lane 235, Pao Chiao Rd, Hsin-Tien Dist., New Taipei City, Taiwan, R.O.C
<b>Equipment</b>	NEC-SIGN
<b>Model No.</b>	xNEC-SIGNxxxxxxxxxxxxx (x can be 0-9, A-Z, a-z, "-", or blank)
<b>Model Discrepancy</b>	All the above models are identical except for the designation of model numbers. The suffix of (x can be 0-9, A-Z, a-z, "-", or blank) on model number is just for marketing purpose only.
<b>Trade Name</b>	AAEON
<b>Received Date</b>	August 2, 2018
<b>Date of Test</b>	August 13 ~ 28, 2018
<b>Output Power (W)</b>	BLE : 0.0016
<b>Power Supply</b>	Power from adapter via power cable. Powertron Electronics Corp. / PA1024-0501B400 I/P: 100-240Vac, 50-60Hz, 0.6A O/P: 5Vdc, 4.0A, 20W Max

## 1.2 EUT CHANNEL INFORMATION

Frequency Range	2402MHz-2480MHz
Modulation Type	GFSK for BLE-1Mbps
Number of channel	40 Channels

**Remark:**

Refer as ANSI 63.10:2013 clause 5.6.1 Table 4 for test channels

Number of frequencies to be tested		
Frequency range in which device operates	Number of frequencies	Location in frequency range of operation
<input type="checkbox"/> 1 MHz or less	1	Middle
<input type="checkbox"/> 1 MHz to 10 MHz	2	1 near top and 1 near bottom
<input checked="" type="checkbox"/> More than 10 MHz	3	1 near top, 1 near middle, and 1 near bottom

## 1.3 ANTENNA INFORMATION

<b>Antenna Type</b>	<input type="checkbox"/> PIFA <input type="checkbox"/> PCB <input checked="" type="checkbox"/> Dipole <input type="checkbox"/> Coils														
<b>Antenna Gain</b>	<table border="1"> <thead> <tr> <th></th> <th>Model name</th> <th>Type</th> <th>Peak Gain</th> </tr> </thead> <tbody> <tr> <td>Ant 1</td> <td>RFA-25-C2M2-M10-1</td> <td>Dipole</td> <td>2dBi</td> </tr> <tr> <td>Ant 2</td> <td>RFA-25-C2M2-M10-1</td> <td>Dipole</td> <td>2dBi</td> </tr> </tbody> </table>				Model name	Type	Peak Gain	Ant 1	RFA-25-C2M2-M10-1	Dipole	2dBi	Ant 2	RFA-25-C2M2-M10-1	Dipole	2dBi
	Model name	Type	Peak Gain												
Ant 1	RFA-25-C2M2-M10-1	Dipole	2dBi												
Ant 2	RFA-25-C2M2-M10-1	Dipole	2dBi												
<b>Antenna connector</b>	SMA Connector														

## 1.4 MEASUREMENT UNCERTAINTY

PARAMETER	UNCERTAINTY
AC Powerline Conducted Emission	+/- 1.2575
Emission bandwidth, 20dB bandwidth	+/- 1.4003
RF output power, conducted	+/- 1.1372
Power density, conducted	+/- 1.4003
3M Semi Anechoic Chamber / 30M~200M	+/- 4.0138
3M Semi Anechoic Chamber / 200M~1000M	+/- 3.9483
3M Semi Anechoic Chamber / 1G~8G	+/- 2.5975
3M Semi Anechoic Chamber / 8G~18G	+/- 2.6112
3M Semi Anechoic Chamber / 18G~26G	+/- 2.7389

**Remark:**

1. This uncertainty represents an expanded uncertainty expressed at approximately the 95% confidence level using a coverage factor of  $k=2$
2. ISO/IEC 17025 requires that an estimate of the measurement uncertainties associated with the emissions test results be included in the report.

## 1.5 FACILITIES AND TEST LOCATION

All measurement facilities used to collect the measurement data are located at No.11, Wugong 6th Rd., Wugu Dist., New Taipei City 24891, Taiwan. (R.O.C.)

Test site	Test Engineer	Remark
AC Conduction Room	Dally Hong	-
Radiation	Jerry Chuang	-
RF Conducted	Dally Hong	-

**Remark:** The sites are constructed in conformance with the requirements of ANSI C63.7, ANSI C63.4 and CISPR Publication 22.

Report No.: T180802D05-RP2

## 1.6 INSTRUMENT CALIBRATION

RF Conducted Test Site					
Equipment	Manufacturer	Model	Serial Number	Calibration Date	Calibration Due
Coaxial Cable	Woken	WC12	CC002	06/29/2018	06/28/2019
Thermostatic/Hrgrosatic Chamber	TAICHY	MHG-150LF	930619	10/11/2017	10/10/2018
Power Meter	Anritsu	ML2495A	1149001	09/18/2017	09/17/2018
Power Sensor	Anritsu	MA2491A	30982	02/06/2018	02/05/2019
Signal Analyzer	R&S	FSV 40	101073	10/02/2017	10/01/2018

3M 966 Chamber Test Site					
Equipment	Manufacturer	Model	Serial Number	Calibration Date	Calibration Due
Band Reject Filters	MICRO TRONICS	BRM 50702	120	05/14/2018	05/13/2019
Bilog Antenna	Sunol Sciences	JB3	A030105	07/13/2018	07/12/2019
Cable	HUBER SUHNER	SUCOFLEX 104PEA	25157	06/29/2018	06/28/2019
Cable	HUBER SUHNER	SUCOFLEX 104PEA	20995	06/29/2018	06/28/2019
Digital Thermo-Hygro Meter	WISEWIND	1206	D07	02/08/2018	02/07/2019
double Ridged Guide Horn Antenna	ETC	MCTD 1209	DRH13M02003	08/20/2018	08/19/2019
Loop Ant	COM-POWER	AL-130	121051	03/21/2018	03/20/2019
Pre-Amplifier	EMEC	EM330	060609	06/29/2018	06/28/2019
Pre-Amplifier	HP	8449B	3008A00965	06/29/2018	06/28/2019
PSA Series Spectrum Analyzer	Agilent	E4446A	MY46180323	05/31/2018	05/30/2019
Antenna Tower	CCS	CC-A-1F	N/A	N.C.R	N.C.R
Controller	CCS	CC-C-1F	N/A	N.C.R	N.C.R
Turn Table	CCS	CC-T-1F	N/A	N.C.R	N.C.R
Software	EZ-EMC (CCS-3A1RE)				

AC Conducted Emissions Test Site					
Equipment	Manufacturer	Model	Serial Number	Calibration Date	Calibration Due
CABLE	EMCI	CFD300-NL	CERF	07/03/2018	07/02/2019
EMI Test Receiver	R&S	ESCI	100064	07/24/2018	07/23/2019
LISN	SCHWARZBECK	NSLK 8127	8127-541	02/09/2018	02/08/2019
LISN	SCHAFFNER	NNB41	03/10013	02/06/2018	02/05/2019
Software	EZ EMC				

**Note:**

1. The calibration interval of the above test instruments is 12 months and the calibrations are traceable to NML/ROC and NIST/USA.
2. N.C.R. = No Calibration Required.

## 1.7 SUPPORT AND EUT ACCESSORIES EQUIPMENT

EUT Accessories Equipment					
No.	Equipment	Brand	Model	Series No.	FCC ID
	N/A				

Support Equipment					
No.	Equipment	Brand	Model	Series No.	FCC ID
1	Monitor	DELL	U2410F	N/A	DoC
2	KeyBoard	DELL	SK-8115	T3A002	DoC
3	Mouse	DELL	M-UAL-96	R41105	DoC

## 1.8 TEST METHODOLOGY AND APPLIED STANDARDS

The test methodology, setups and results comply with all requirements in accordance with ANSI C63.10:2013, FCC Part 2, FCC Part 15.247, KDB 558074 D01.



Report No.: T180802D05-RP2

## 2. TEST SUMMERY

FCC Standard Section	Report Section	Test Item	Result
15.203	1.3	Antenna Requirement	Pass
15.207(a)	4.1	AC Conducted Emission	Pass
15.247(a)(2)	4.2	6 dB Bandwidth	Pass
2.1049	4.2	Occupied Bandwidth (99%)	Pass
15.247(b)(3)	4.3	Output Power Measurement	Pass
15.247(e)	4.4	Power Spectral Density	Pass
15.247(d)	4.5	Conducted Band Edge	Pass
15.247(d)	4.5	Conducted Spurious Emission	Pass
15.247(d)	4.6	Radiation Band Edge	Pass
15.247(d)	4.6	Radiation Spurious Emission	Pass

### 3. DESCRIPTION OF TEST MODES

#### 3.1 THE WORST MODE OF OPERATING CONDITION

Operation mode	BLE Mode (1Mbps)
Test Channel Frequencies	1.Lowest Channel : 2402MHz 2.Middle Channel : 2440MHz 3.Highest Channel : 2480MHz

**Remark:**

1. EUT pre-scanned data rate of output power for each mode, the worst data rate were recorded in this report.

### 3.2 THE WORST MODE OF MEASUREMENT

AC Power Line Conducted Emission	
Test Condition	AC Power line conducted emission for line and neutral
Power supply Mode	Mode 1:EUT power by adapter via power cable
Worst Mode	<input checked="" type="checkbox"/> Mode 1 <input type="checkbox"/> Mode 2 <input type="checkbox"/> Mode 3 <input type="checkbox"/> Mode 4

Radiated Emission Measurement Above 1G	
Test Condition	Band edge, Emission for Unwanted and Fundamental
Power supply Mode	Mode 1:EUT power by adapter via power cable
Worst Mode	<input checked="" type="checkbox"/> Mode 1 <input type="checkbox"/> Mode 2 <input type="checkbox"/> Mode 3 <input type="checkbox"/> Mode 4
Worst Position	<input type="checkbox"/> Placed in fixed position. <input type="checkbox"/> Placed in fixed position at X-Plane (E2-Plane) <input checked="" type="checkbox"/> Placed in fixed position at Y-Plane (E1-Plane) <input type="checkbox"/> Placed in fixed position at Z-Plane (H-Plane)
Worst Polarity	<input type="checkbox"/> Horizontal <input checked="" type="checkbox"/> Vertical

Radiated Emission Measurement Below 1G	
Test Condition	Radiated Emission Below 1G
Power supply Mode	Mode 1:EUT power by adapter via power cable
Worst Mode	<input checked="" type="checkbox"/> Mode 1 <input type="checkbox"/> Mode 2 <input type="checkbox"/> Mode 3 <input type="checkbox"/> Mode 4

*Remark:*

1. The worst mode was record in this test report.
2. EUT pre-scanned in three axis ,X,Y, Z and two polarity, Horizontal and Vertical for radiated measurement. The worst case(Y-Plane and Vertical) were recorded in this report
3. AC power line conducted emission and for below 1G radiation emission were performed the EUT transmit at the highest output power channel as worse case.

Report No.: T180802D05-RP2

### 3.3 EUT DUTY CYCLE

Duty Cycle			
Configuration	TX ON (ms)	TX ALL (ms)	Duty Cycle (%)
BLE	0.4400	0.6300	69.84%

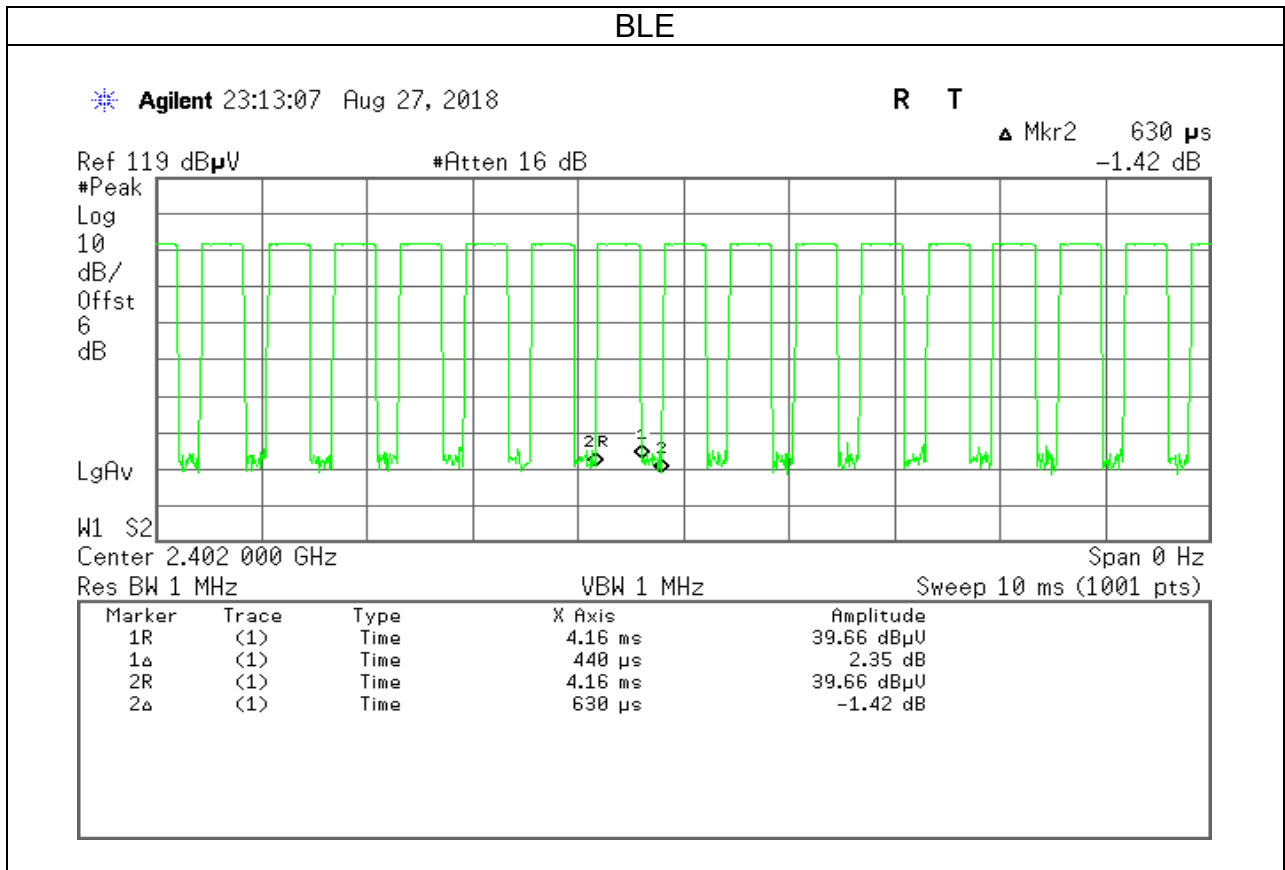

Report No.: T180802D05-RP2

## 4. TEST RESULT

### 4.1 AC POWER LINE CONDUCTED EMISSION

#### 4.1.1 Test Limit

According to §15.207(a),

Frequency Range (MHz)	Limits(dB $\mu$ V)	
	Quasi-peak	Average
0.15 to 0.50	66 to 56*	56 to 46*
0.50 to 5	56	46
5 to 30	60	50

\* Decreases with the logarithm of the frequency.

#### 4.1.2 Test Procedure

Test method Refer as ANSI 63.10:2013 clause 6.2,

1. The EUT was placed above horizontal ground plane and 0.4m above vertical ground plane
2. EUT connected to the line impedance stabilization network (LISN)
3. Receiver set RBW of 9kHz and Detector Peak, and note as quasi-peak and average.
4. Maximum procedure was performed on the six highest emissions to ensure EUT compliance.
5. Recorded Line for Neutral and Line.

#### 4.1.3 Test Setup

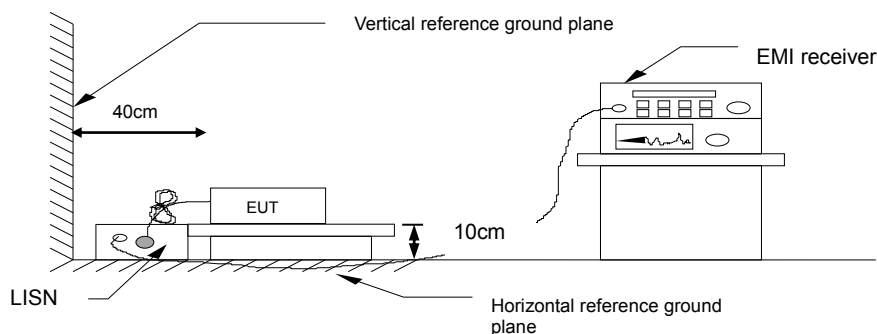

#### 4.1.4 Test Result

**Pass.**

Report No.: T180802D05-RP2

Test Mode:	Mode 1	Temp/Hum	24(°C) / 50%RH
Phase:	Line	Test Date	August 13, 2018
Test Voltage:	120V	Test Engineer	Dally Hong

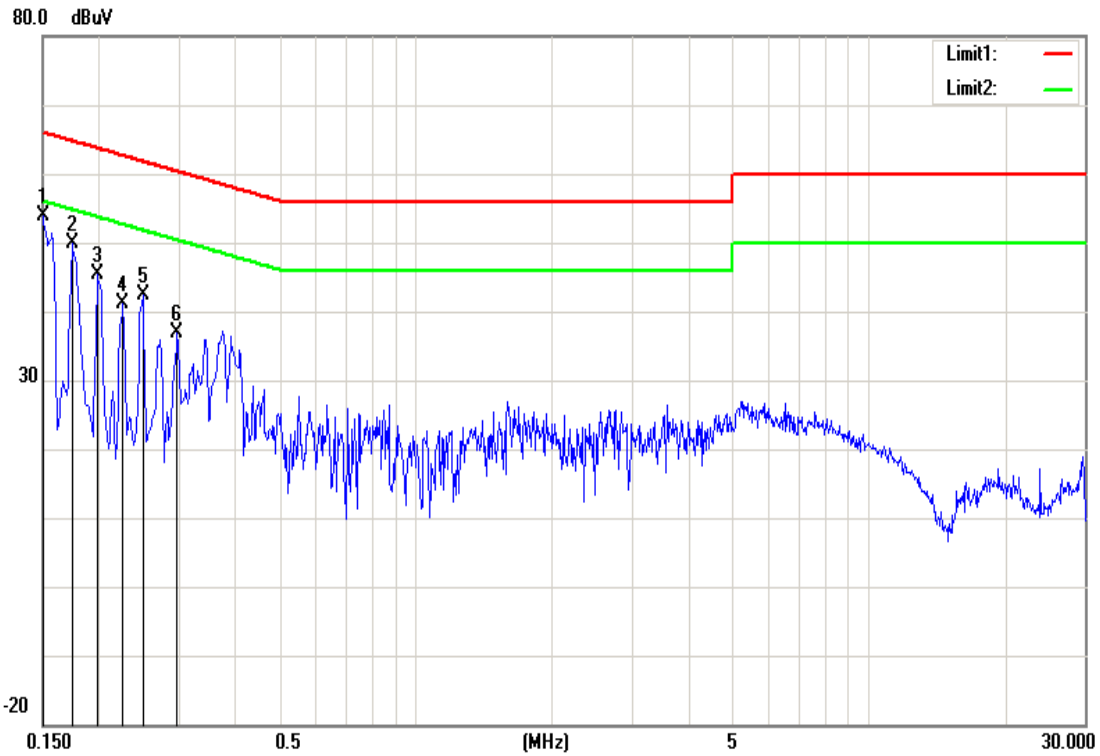

No.	Frequency (MHz)	QuasiPeak reading (dBuV)	Average reading (dBuV)	Correction factor (dB)	QuasiPeak result (dBuV)	Average result (dBuV)	QuasiPeak limit (dBuV)	Average limit (dBuV)	QuasiPeak margin (dB)	Average margin (dB)	Remark
1	0.1500	51.64	33.05	0.11	51.75	33.16	65.99	56.00	-14.24	-22.84	Pass
2*	0.1740	46.12	28.61	0.11	46.23	28.72	64.76	54.77	-18.53	-26.05	Pass
3	0.1980	41.96	24.98	0.11	42.07	25.09	63.69	53.69	-21.62	-28.60	Pass
4	0.2260	39.81	22.78	0.11	39.92	22.89	62.59	52.60	-22.67	-29.71	Pass
5	0.2500	35.78	17.76	0.11	35.89	17.87	61.75	51.76	-25.86	-33.89	Pass
6	0.2980	30.77	16.88	0.11	30.88	16.99	60.30	50.30	-29.42	-33.31	Pass

Report No.: T180802D05-RP2

Test Mode:	Mode 1	Temp/Hum	24(°C) / 50%RH
Phase:	Neutral	Test Date	August 13, 2018
Test Voltage:	120V	Test Engineer	Dally Hong

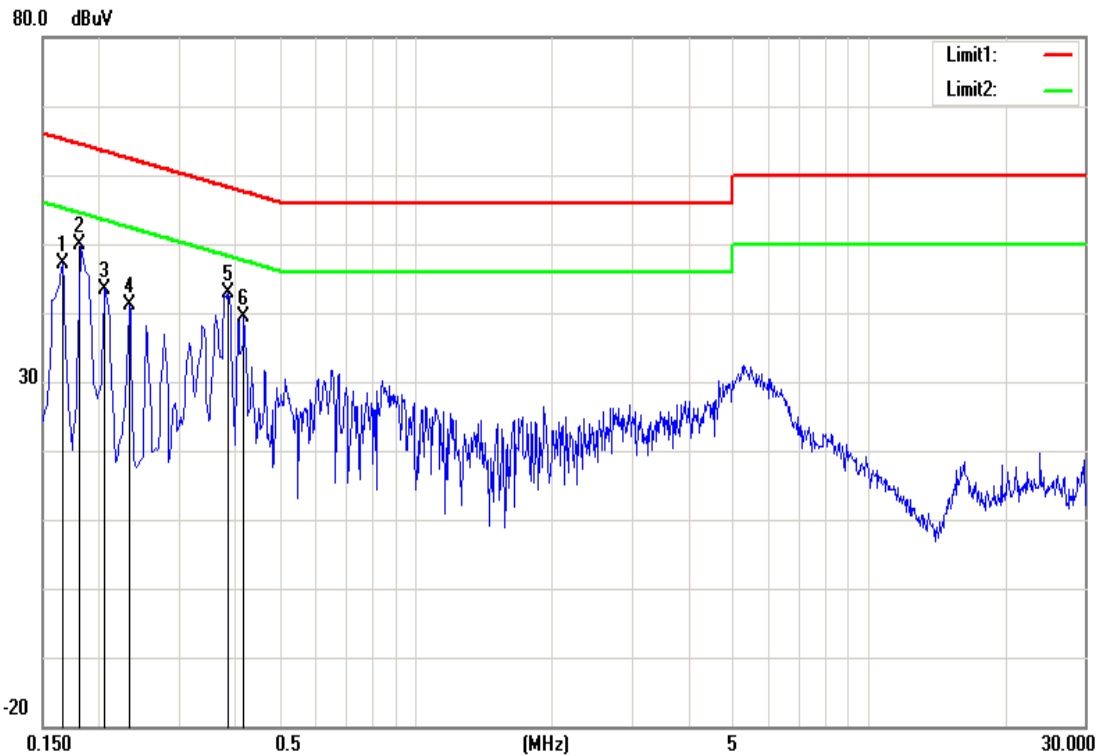

No.	Frequency (MHz)	QuasiPeak reading (dBuV)	Average reading (dBuV)	Correction factor (dB)	QuasiPeak result (dBuV)	Average result (dBuV)	QuasiPeak limit (dBuV)	Average limit (dBuV)	QuasiPeak margin (dB)	Average margin (dB)	Remark
1	0.1660	48.37	30.29	0.14	48.51	30.43	65.16	55.16	-16.65	-24.73	Pass
2*	0.1820	47.79	29.28	0.13	47.92	29.41	64.39	54.39	-16.47	-24.98	Pass
3	0.2060	44.03	26.49	0.13	44.16	26.62	63.37	53.37	-19.21	-26.75	Pass
4	0.2340	39.20	21.74	0.13	39.33	21.87	62.31	52.31	-22.98	-30.44	Pass
5	0.3860	44.49	39.57	0.13	44.62	39.70	58.15	48.15	-13.53	-8.45	Pass
6	0.4180	38.88	27.31	0.13	39.01	27.44	57.49	47.49	-18.48	-20.05	Pass

Report No.: T180802D05-RP2

## 4.2 6dB BANDWIDTH AND OCCUPIED BANDWIDTH(99%)

### 4.2.1 Test Limit

According to §15.247(a)(2),

#### 6 dB Bandwidth :

Limit	Shall be at least 500kHz
-------	--------------------------

Occupied Bandwidth(99%) : For reporting purposes only.

### 4.2.2 Test Procedure

Test method Refer as KDB 558074 D01 and ANSI 63.10:2013 clause 6.9.2,

1. The EUT RF output connected to the spectrum analyzer by RF cable.
2. Setting maximum power transmit of EUT.
3. SA set RBW = 100KHz, VBW = 300KHz and Detector = Peak, to measurement 6dB Bandwidth.
4. SA set RBW = 1% ~ 5% OBW, VBW = three times the RBW and Detector = Peak, to measurement 99% Bandwidth.
5. Measure and record the result of 6 dB Bandwidth and 99% Bandwidth. in the test report.

### 4.2.3 Test Setup

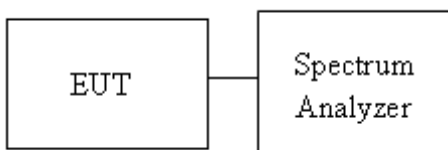

### 4.2.4 Test Result

Test mode: BLE mode / 2402-2480 MHz				
Channel	Frequency (MHz)	OBW(99%) (MHz)	6dB BW (MHz)	6dB limit (kHz)
Low	2402	1.0549	0.6903	>500
Mid	2440	1.0506	0.7164	
High	2480	1.0506	0.7164	



Report No.: T180802D05-RP2

## 6dB BW Test Data

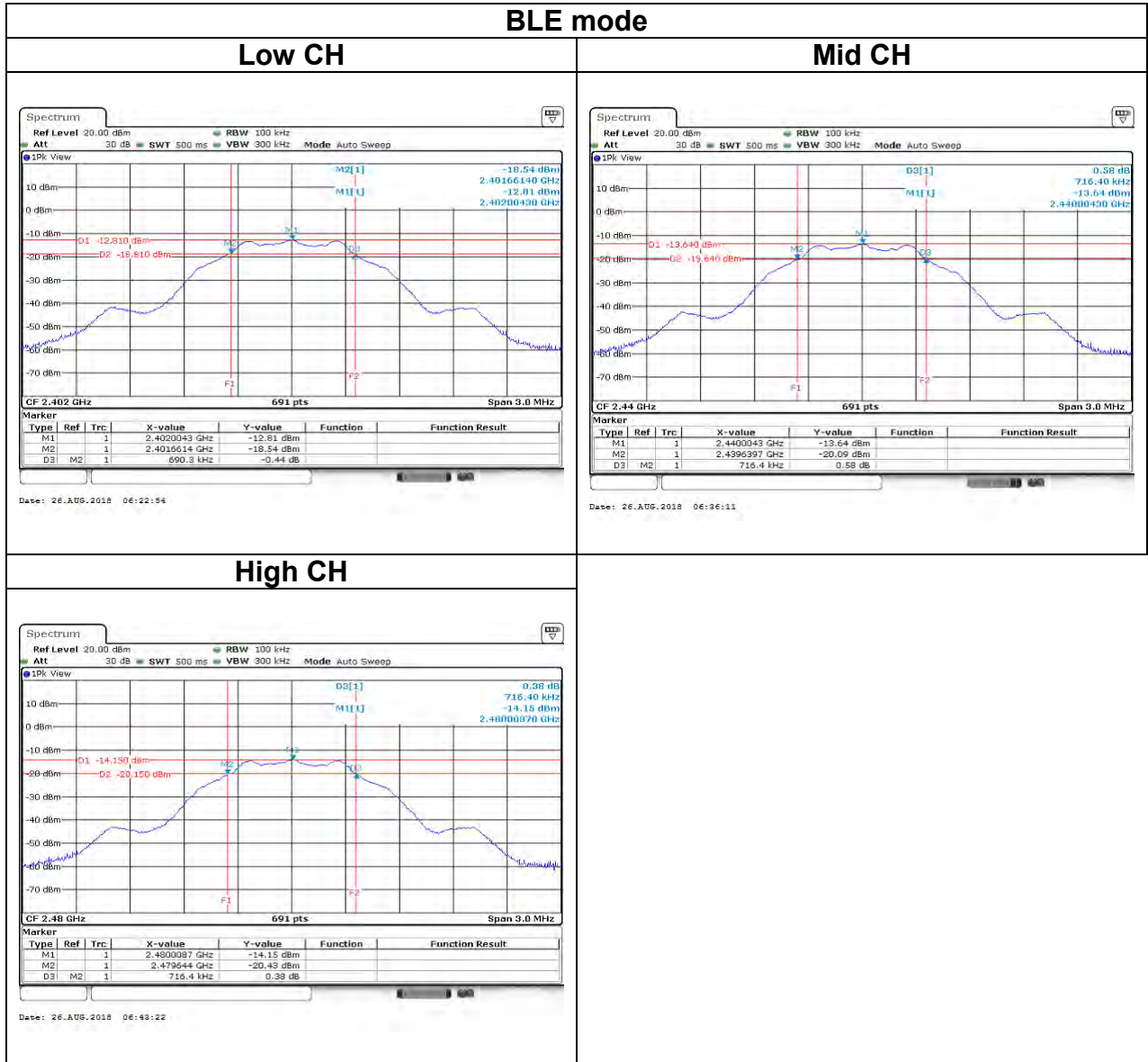

## OBW(99%) Test Data

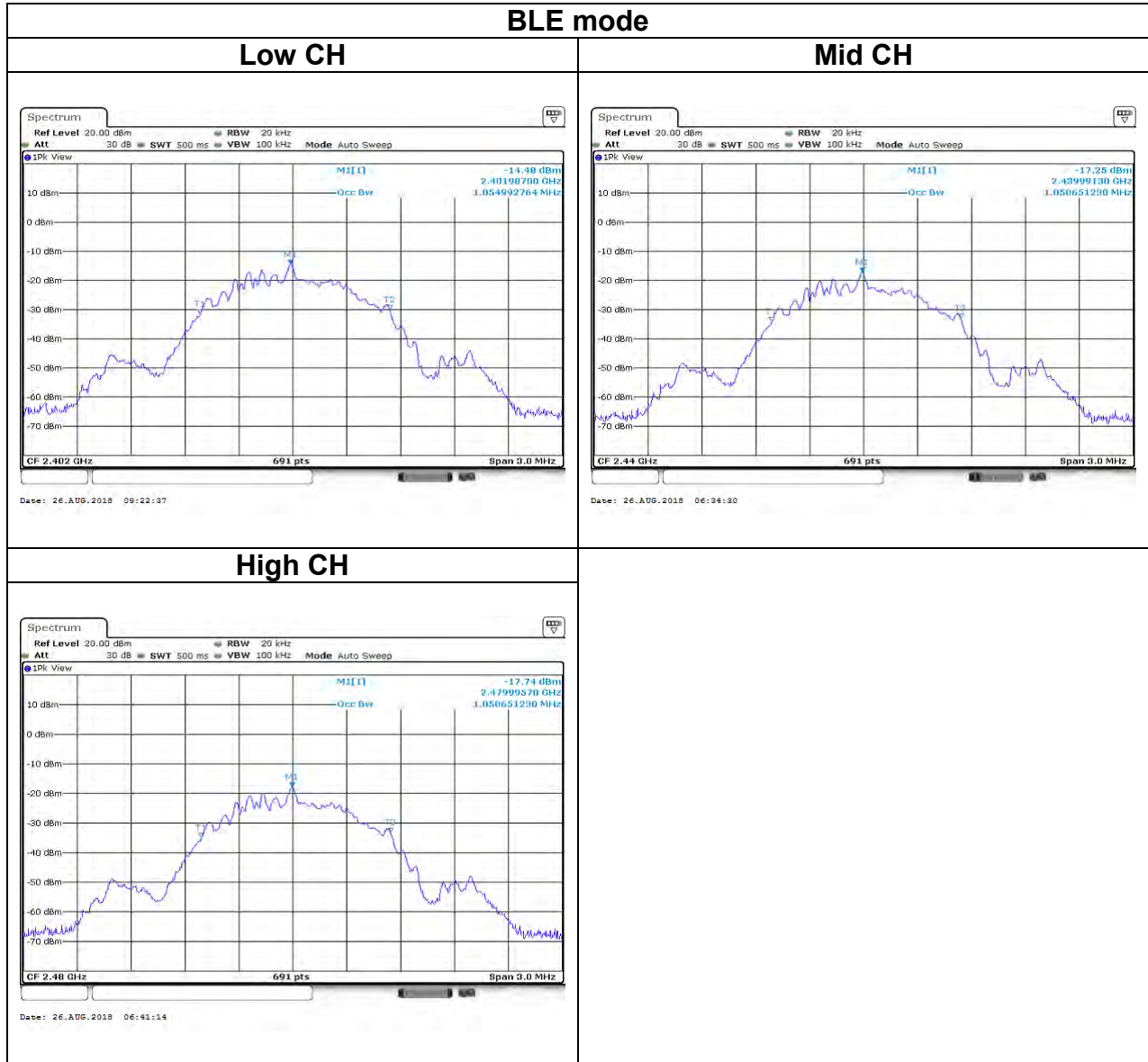

## 4.3 OUTPUT POWER MEASUREMENT

### 4.3.1 Test Limit

According to §15.247(b)(3).

#### Peak output power :

For systems using digital modulation in the 2400-2483.5 MHz: 1 Watt(30 dBm), base on the use of antennas with directional gain not exceed 6 dBi If transmitting antennas of directional gain greater than 6dBi are used the peak output power the conducted output power from the intentional radiator shall be reduced by the amount in dB that the directional gain of the antenna exceeds 6 dBi. In case of point-to-point operation, the limit has to be reduced by 1dB for every 3 dB that the directional gain of the antenna exceeds 6 dBi.

Limit	<input checked="" type="checkbox"/> Antenna not exceed 6 dBi : 30dBm <input type="checkbox"/> Antenna with DG greater than 6 dBi [ Limit = 30 – (DG – 6) ] <input type="checkbox"/> Point-to-point operation
-------	---

Average output power : For reporting purposes only.

### 4.3.2 Test Procedure

Test method Refer as KDB 558074 D01.

1. The EUT RF output connected to the power meter by RF cable.
2. Setting maximum power transmit of EUT.
3. The path loss was compensated to the results for each measurement.
4. Measure and record the result of Peak output power and Average output power. in the test report.

### 4.3.3 Test Setup

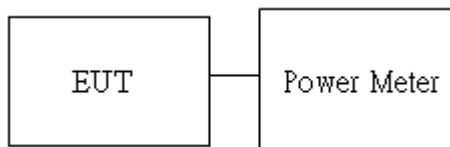

### 4.3.4 Test Result

**Peak output power :**

BLE Mode					
Config.	CH	Freq. (MHz)	PK Power (dBm)	PK Power (W)	FCC Limit (dBm)
BLE Data rate: 1Mbps	0	2402	2.13	0.0016	30
	19	2440	1.73	0.0015	
	39	2480	0.91	0.0012	

**Average output power :**

BLE Mode			
Config.	CH	Freq. (MHz)	AV Power (dBm)
BLE Data rate: 1Mbps	0	2402	1.75
	19	2440	1.33
	39	2480	0.44

Report No.: T180802D05-RP2

## 4.4 POWER SPECTRAL DENSITY

### 4.4.1 Test Limit

According to §15.247(e),

For digitally modulated systems, the power spectral density conducted from the intentional radiator to the antenna shall not be greater than 8 dBm in any 3 kHz band during any time interval of continuous transmission.

Limit	<input checked="" type="checkbox"/> Antenna not exceed 6 dBi : 8dBm <input type="checkbox"/> Antenna with DG greater than 6 dBi [ Limit = 8 – (DG – 6) ] <input type="checkbox"/> Point-to-point operation :
-------	---

### 4.4.2 Test Procedure

Test method Refer as KDB 558074 D01

1. The EUT RF output connected to the spectrum analyzer by RF cable.
2. Setting maximum power transmit of EUT
3. SA set RBW = 3kHz, VBW = 30kHz, Span = 1.5 times DTS Bandwidth (6 dB BW), Detector = Peak, Sweep Time = Auto and Trace = Max hold.
4. The path loss was compensated to the results for each measurement by SA.
5. Mark the maximum level.
6. Measure and record the result of power spectral density. in the test report.

### 4.4.3 Test Setup

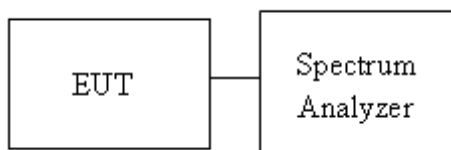

### 4.4.4 Test Result

Test mode: BLE mode / 2402-2480 MHz			
Channel	Frequency (MHz)	PSD (dBm)	FCC limit (dBm)
Low	2402	-16.23	8
Mid	2440	-16.91	
High	2480	-17.35	

## Test Data

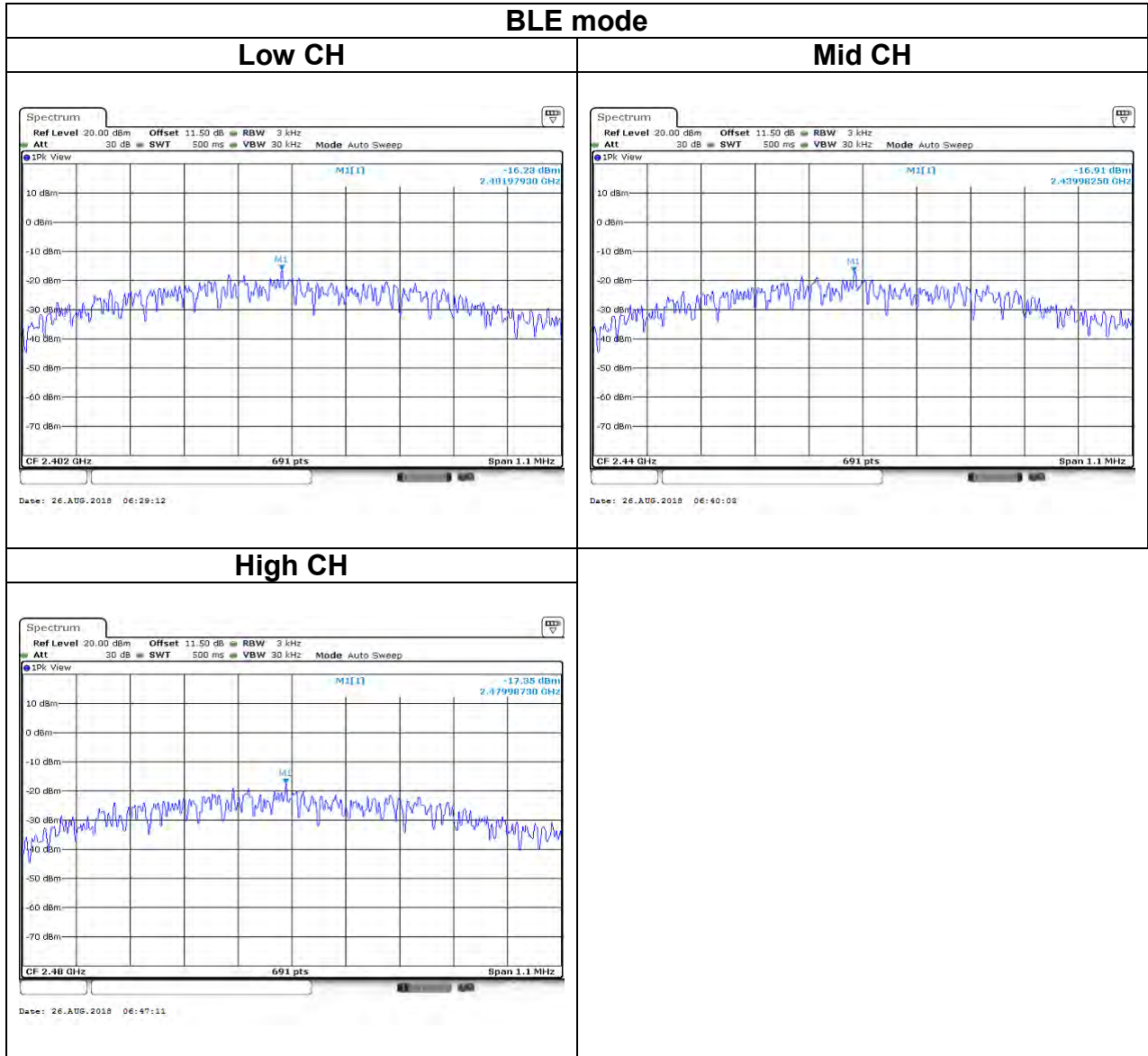

## 4.5 CONDUCTED BAND EDGE AND SPURIOUS EMISSION

### 4.5.1 Test Limit

According to §15.247(d),

In any 100 kHz bandwidth outside the authorized frequency band,

Non-restricted bands shall be attenuated at least 20 dB/30 dB relative to the maximum PSD level in 100 kHz by RF conducted or a radiated measurement which fall in the restricted bands, as defined in §15.205(a), must also comply with the radiated emission limits specified in §15.209(a).

### 4.5.2 Test Procedure

Test method Refer as KDB 558074 D01.

1. EUT RF output port connected to the SA by RF cable, and the path loss was compensated to result.
2. SA setting, RBW=100kHz, VBW=300kHz, Detector=Peak, Trace mode = max hold, SWT = Auto.
3. In any 100 kHz bandwidth outside the authorized frequency band, shall be attenuated at least 20 dB relative to the maximum in-band peak PSD level in 100 kHz when conducted power procedure is used. If the transmitter complies with the conducted power limits based on the use of RMS averaging over a time interval, the attenuation required under this paragraph shall be 30 dB instead of 20 dB.

### 4.5.3 Test Setup

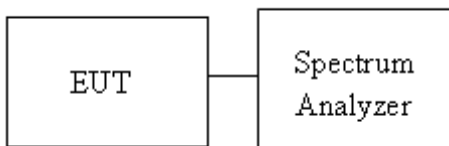

Report No.: T180802D05-RP2

### 4.5.4 Test Result

#### Test Data

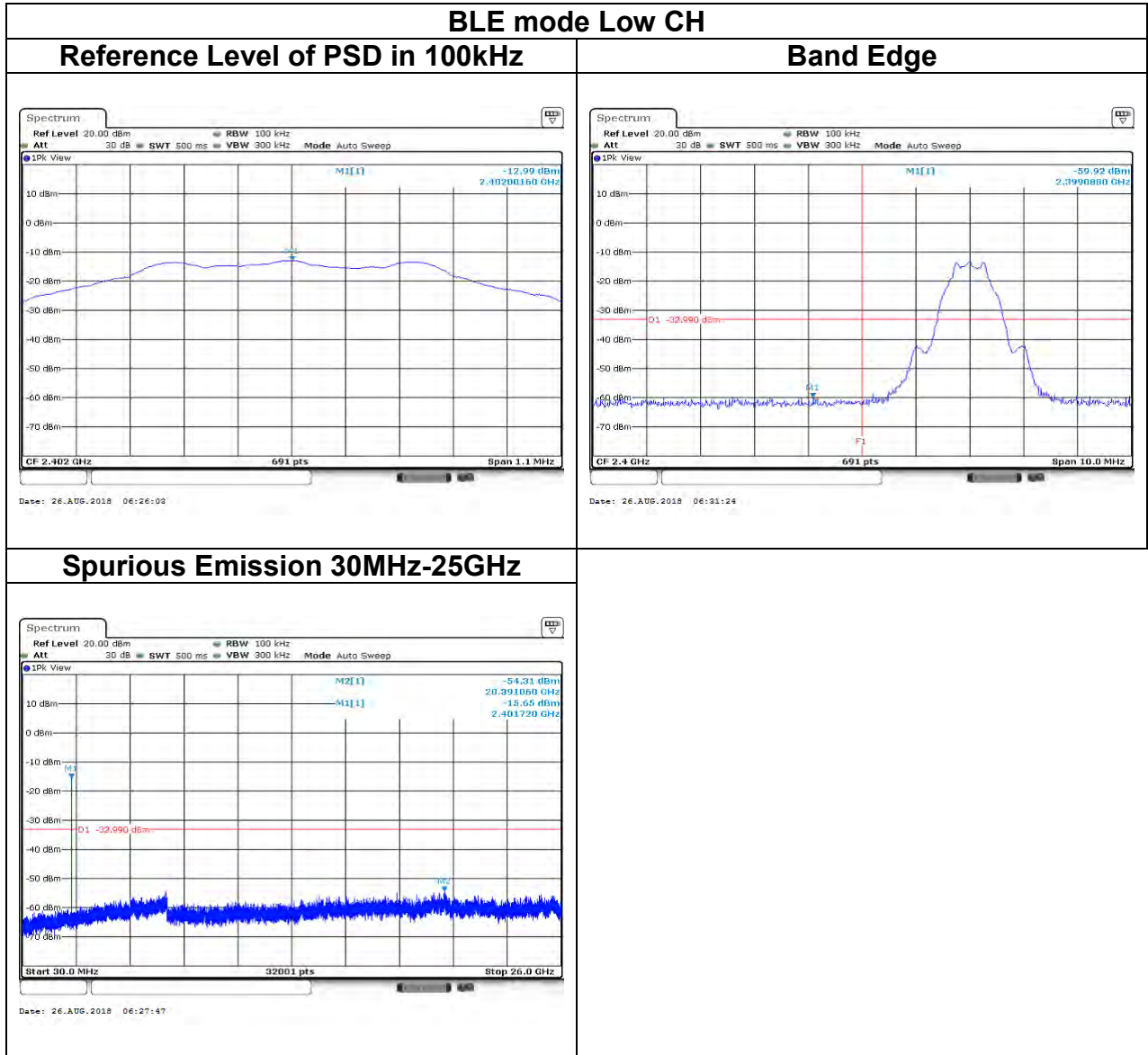



Report No.: T180802D05-RP2

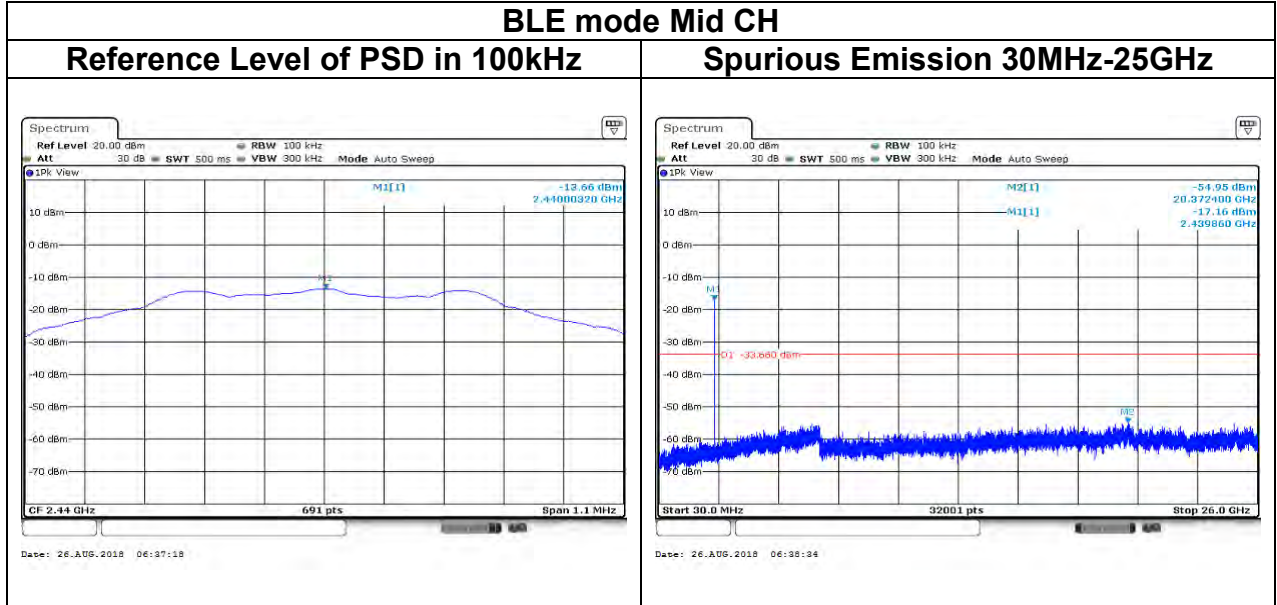

## BLE mode High CH

### Reference Level of PSD in 100kHz



### Band Edge

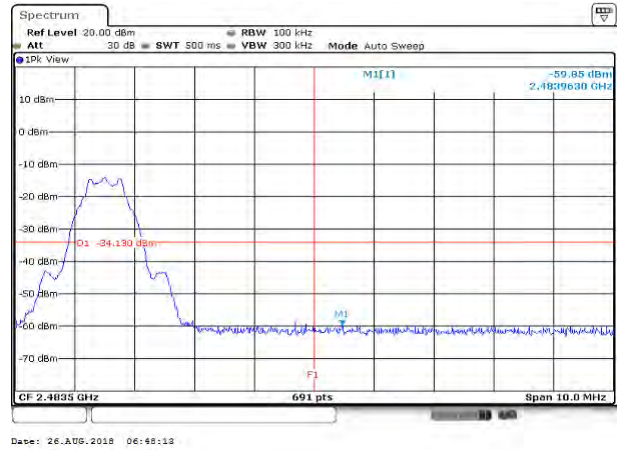

### Spurious Emission 30MHz-25GHz

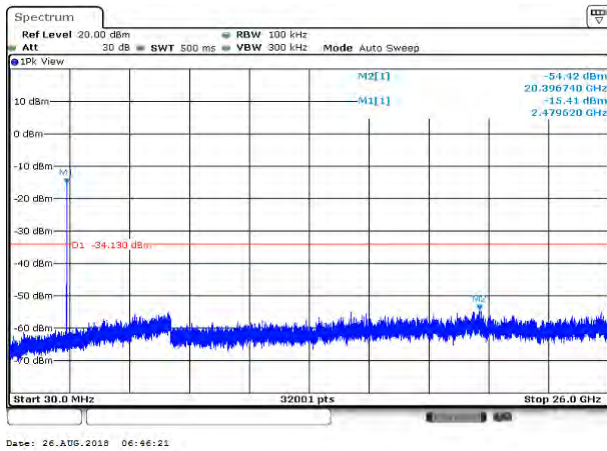

Report No.: T180802D05-RP2

## 4.6 RADIATION BANDEGE AND SPURIOUS EMISSION

### 4.6.1 Test Limit

FCC according to §15.247(d), §15.209 and §15.205,

In any 100 kHz bandwidth outside the authorized frequency band, all harmonic and spurious must be least 20 dB below the highest emission level with the authorized frequency band. Radiation emission which fall in the restricted bands must also follow the FCC section 15.209 as below limit in table.

#### Below 30 MHz

Frequency	Field Strength (microvolts/m)	Magnetic H-Field (microamperes/m)	Measurement Distance (metres)
9-490 kHz	2,400/F (F in kHz)	2,400/F (F in kHz)	300
490-1,705 kHz	24,000/F (F in kHz)	24,000/F (F in kHz)	30
1.705-30 MHz	30	N/A	30

#### Above 30 MHz

Frequency (MHz)	Field Strength microvolts/m at 3 metres (watts, e.i.r.p.)	
	Transmitters	Receivers
30-88	100 (3 nW)	100 (3 nW)
88-216	150 (6.8 nW)	150 (6.8 nW)
216-960	200 (12 nW)	200 (12 nW)
Above 960	500 (75 nW)	500 (75 nW)

Remark:

Although these tests were performed other than open area test site, adequate comparison measurements were confirmed against 30 m open are test site. Therefore sufficient tests were made to demonstrate that the alternative site produces results that correlate with the ones of tests made in an open field based on KDB 414788.

Report No.: T180802D05-RP2

### 4.6.2 Test Procedure

Test method Refer as KDB 558074 D01.

1. The EUT is placed on a turntable, Above 1 GHz is 1.5m and below 1 GHz is 0.8m above ground plane. The EUT Configured un accordance with ANSI C63.10, and the EUT set in a continuous mode.
2. The turntable shall be rotated for 360 degrees to determine the position of maximum emission level. And EUT is set 3m away from the receiving antenna, which is scanned from 1m to 4m above the ground plane to find out the highest emissions. Measurement are made polarized in both the vertical and the horizontal positions with antenna.
3. Span shall wide enough to full capture the emission measured. The SA from 9KHz to 26.5GHz set to the low, Mid and High channels with the EUT transmit.
4. No emission found between lowest internal used/generated frequency to 30MHz (9KHz~30MHz)

Remark:

Although these tests were performed other than open area test site, adequate comparison measurements were confirmed against 30 m open are test site. Therefore sufficient tests were made to demonstrate that the alternative site produces results that correlate with the ones of tests made in an open field based on KDB 414788.

5. The SA setting following :

- (1) Below 1G : RBW = 100kHz, VBW  $\geq$  3 RBW, Sweep = Auto, Detector = Peak, Trace = Max hold.
- (2) Above 1G :
  - (2.1) For Peak measurement : RBW = 1MHz, VBW  $\geq$  3 RBW, Sweep = Auto, Detector = Peak, Trace = Max hold.
  - (2.2) For Average measurement : RBW = 1MHz, VBW
    - If Duty Cycle  $\geq$  98%, VBW=10Hz.
    - If Duty Cycle < 98%, VBW=1/T.

Configuration	Duty Cycle (%)	TX ON (ms)	1/T (kHz)	VBW Setting
BLE	70%	0.4400	2.273	2.4K

Report No.: T180802D05-RP2

### 4.6.3 Test Setup

#### 9kHz ~ 30MHz

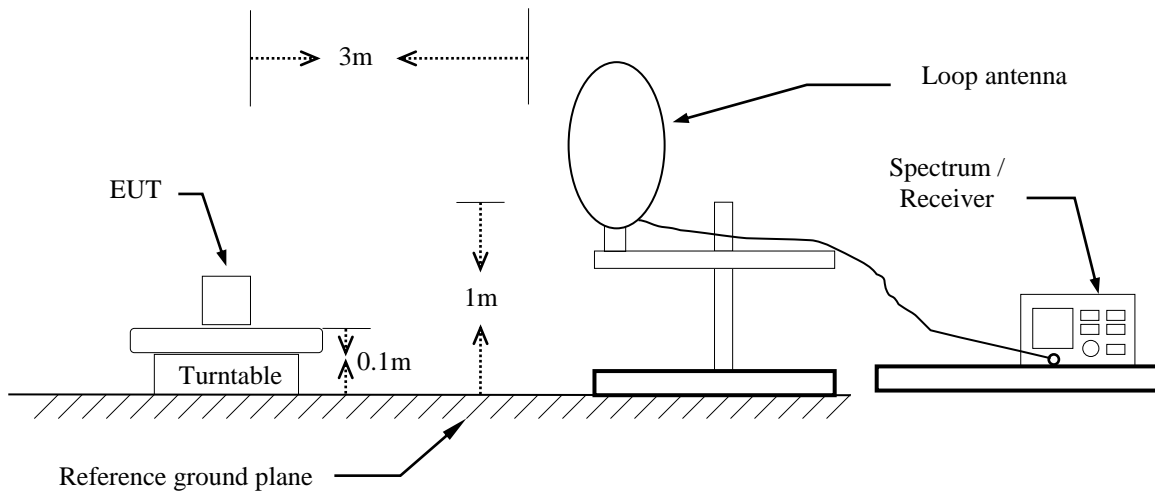

#### 30MHz ~ 1GHz

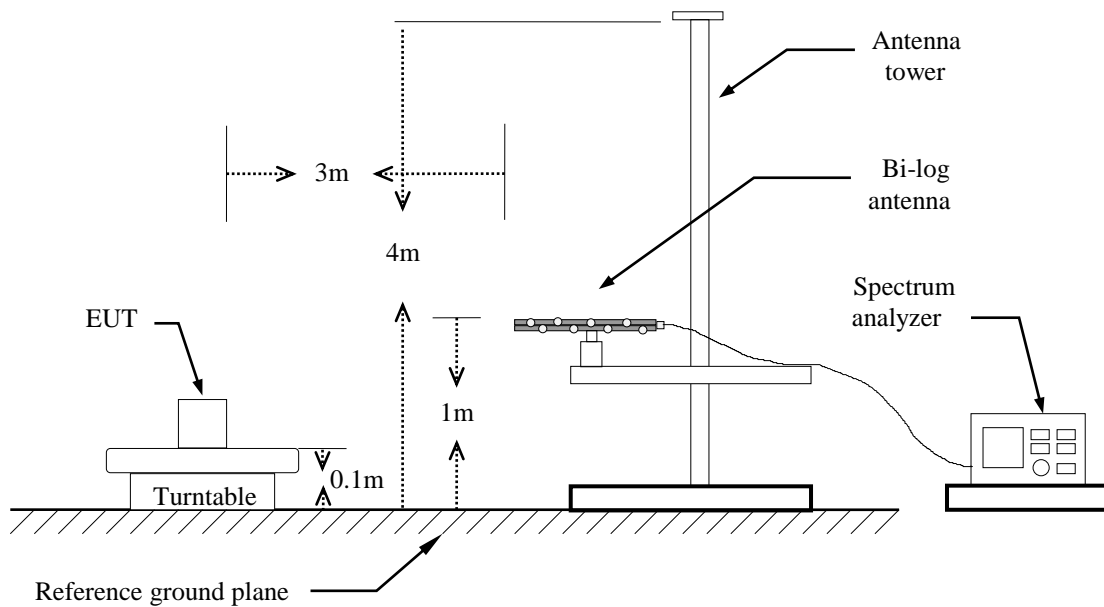

## Above 1 GHz

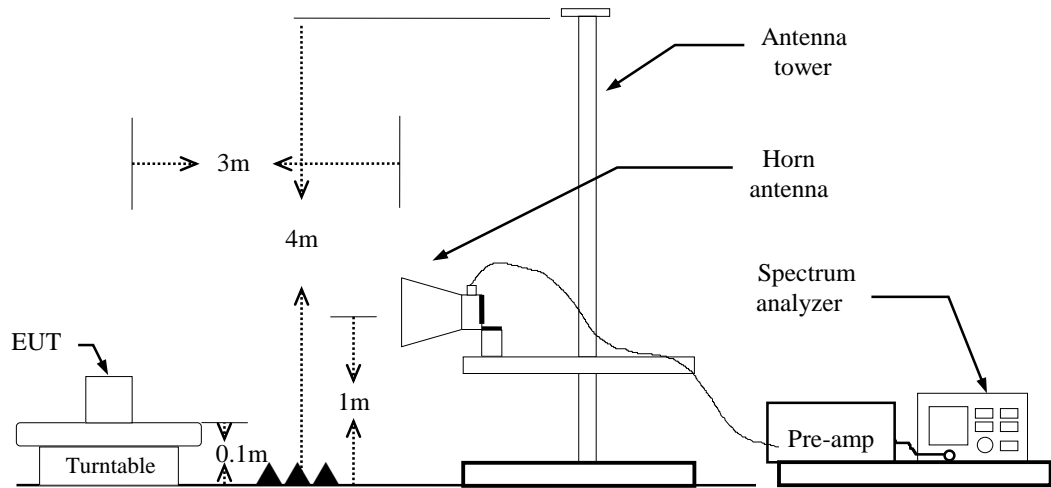

Report No.: T180802D05-RP2

### 4.6.4 Test Result

#### Band Edge Test Data

Test Mode:	BLE Low CH	Temp/Hum	22(°C)/ 34%RH
Test Item	Band Edge	Test Date	August 28, 2018
Polarize	Vertical	Test Engineer	Jerry Chuang
Detector	Peak		

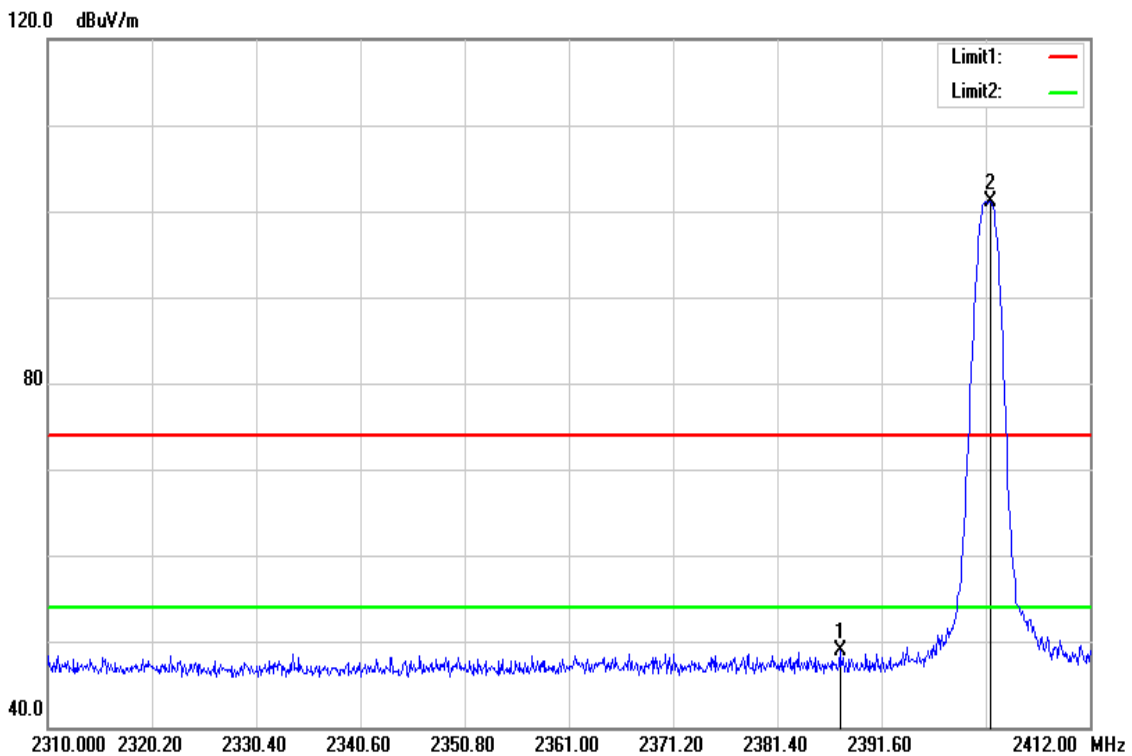

Frequency (MHz)	Reading (dBuV)	Correct Factor (dB/m)	Result (dBuV/m)	Limit (dBuV/m)	Margin (dB)	Remark
2387.520	52.02	-3.12	48.90	74.00	-25.10	peak
2402.208	104.25	-3.13	101.12	-	-	peak

Report No.: T180802D05-RP2

Test Mode:	BLE Low CH	Temp/Hum	22(°C)/ 34%RH
Test Item	Band Edge	Test Date	August 28, 2018
Polarize	Vertical	Test Engineer	Jerry Chuang
Detector	Average		

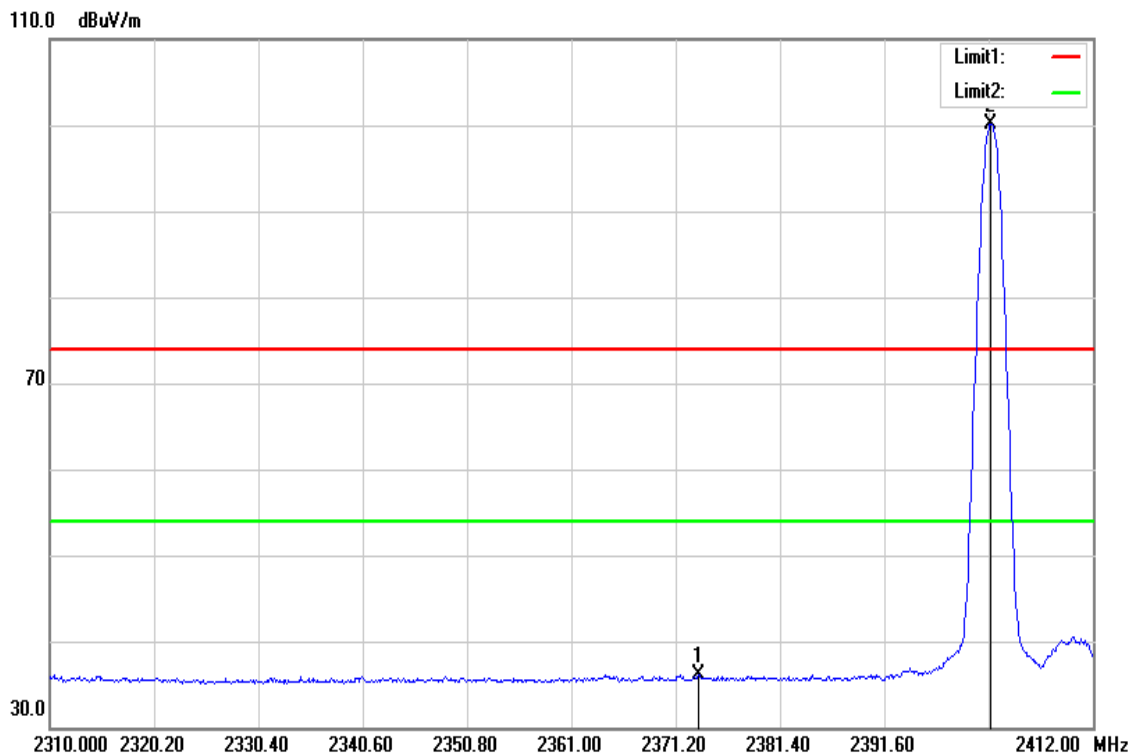

Frequency (MHz)	Reading (dBuV)	Correct Factor (dB/m)	Result (dBuV/m)	Limit (dBuV/m)	Margin (dB)	Remark
2373.444	39.18	-3.10	36.08	74.00	-37.92	peak
2402.004	103.28	-3.13	100.15	-	-	peak



Report No.: T180802D05-RP2

Test Mode:	BLE High CH	Temp/Hum	22(°C)/ 34%RH
Test Item	Band Edge	Test Date	August 28, 2018
Polarize	Vertical	Test Engineer	Jerry Chuang
Detector	Peak		

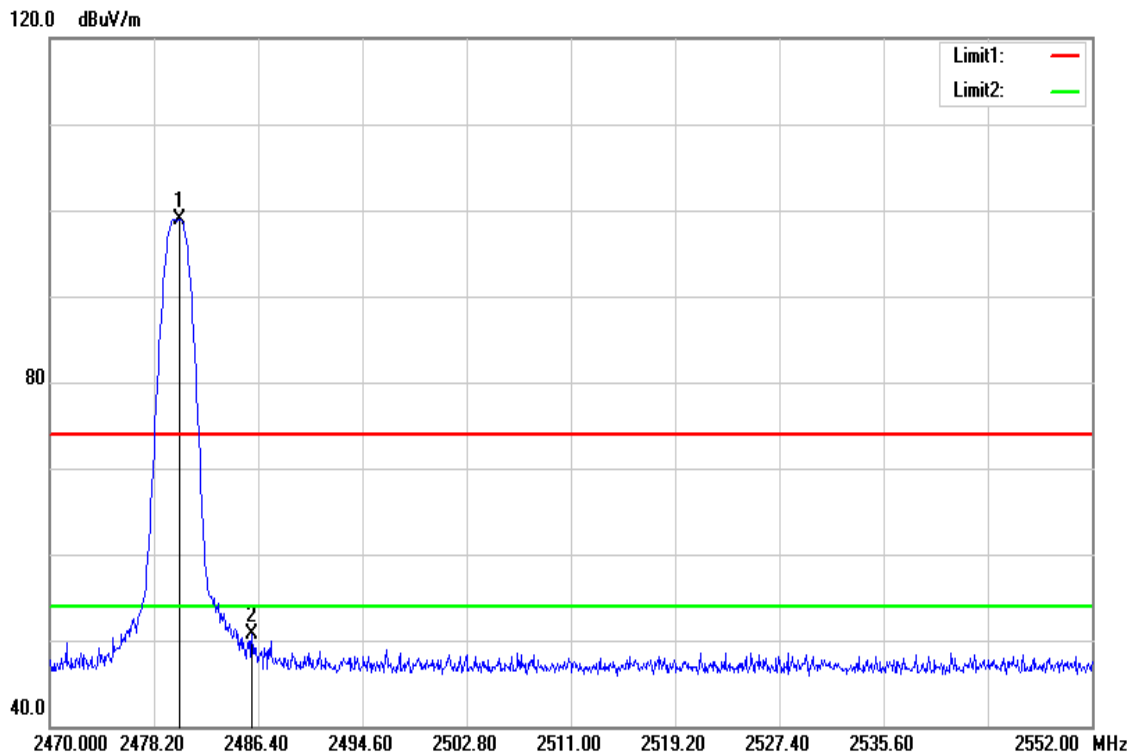

Frequency (MHz)	Reading (dBuV)	Correct Factor (dB/m)	Result (dBuV/m)	Limit (dBuV/m)	Margin (dB)	Remark
2480.250	101.68	-2.73	98.95	-	-	peak
2485.908	53.46	-2.70	50.76	74.00	-23.24	peak

Report No.: T180802D05-RP2

Test Mode:	BLE High CH	Temp/Hum	22(°C)/ 34%RH
Test Item	Band Edge	Test Date	August 28, 2018
Polarize	Vertical	Test Engineer	Jerry Chuang
Detector	Average		

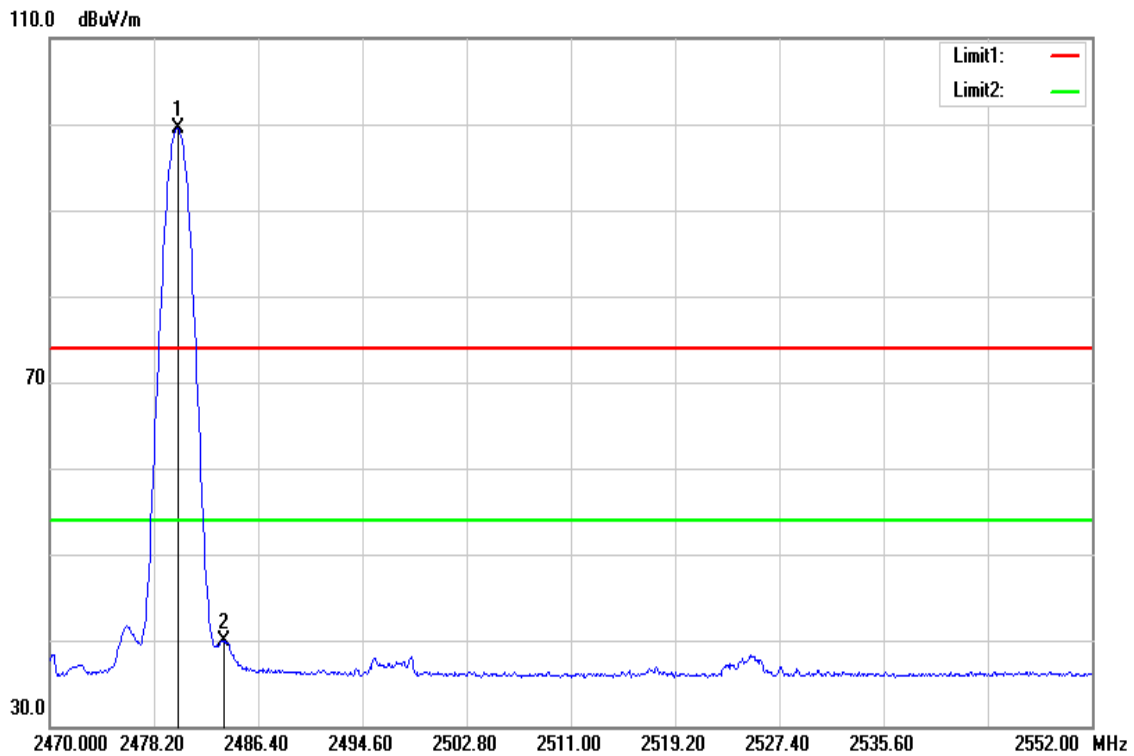

Frequency (MHz)	Reading (dBuV)	Correct Factor (dB/m)	Result (dBuV/m)	Limit (dBuV/m)	Margin (dB)	Remark
2480.086	102.15	-2.73	99.42	-	-	AVG
2483.694	42.63	-2.71	39.92	54.00	-14.08	AVG

Report No.: T180802D05-RP2

**Below 1G Test Data**

Test Mode:	BLE Mode	Temp/Hum	22(°C)/ 34%RH
Test Item	30MHz-1GHz	Test Date	August 28, 2018
Polarize	Vertical	Test Engineer	Jerry Chuang
Detector	Peak		

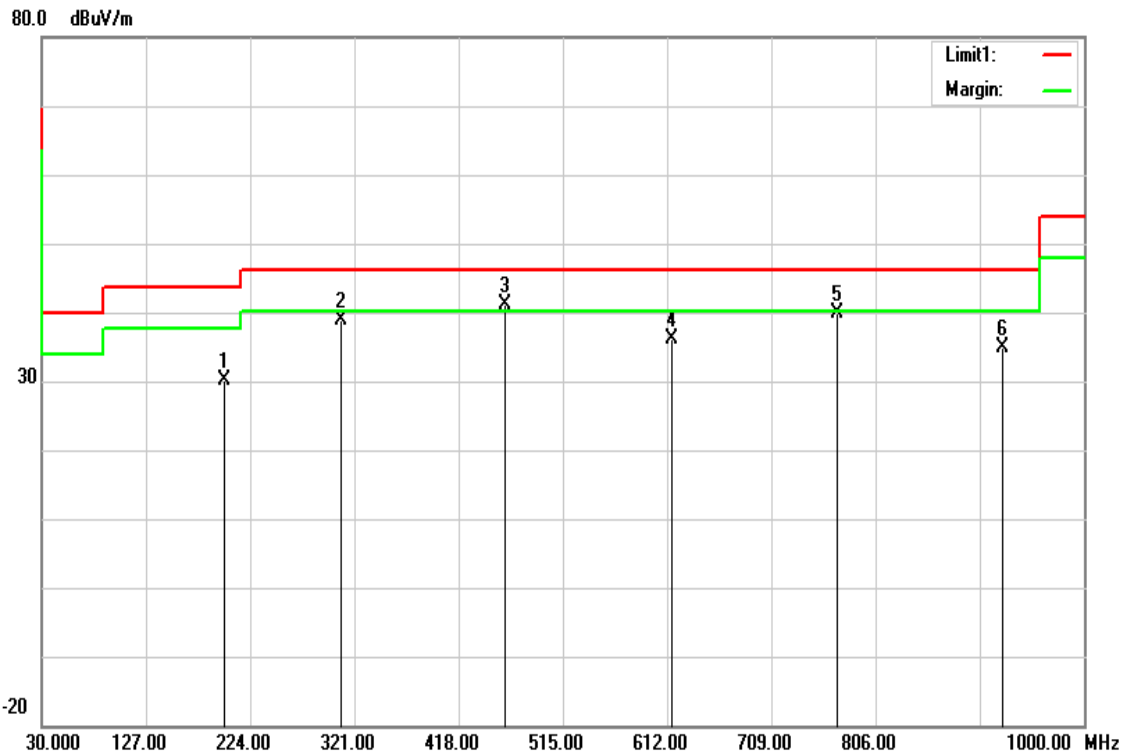

Frequency (MHz)	Reading (dBuV)	Correct Factor (dB/m)	Result (dBuV/m)	Limit (dBuV/m)	Margin (dB)	Remark
199.7500	38.91	-8.74	30.17	43.52	-13.35	peak
308.3900	46.07	-7.25	38.82	46.02	-7.20	QP
461.6500	43.97	-2.95	41.02	46.02	-5.00	QP
615.8800	36.20	-0.16	36.04	46.02	-9.98	peak
770.1100	37.58	2.39	39.97	46.02	-6.05	QP
924.3400	29.99	4.91	34.90	46.02	-11.12	peak

**Note:** No emission found between lowest internal used/generated frequency to 30MHz(9KHz~30MHz)

Report No.: T180802D05-RP2

Test Mode:	BLE Mode	Temp/Hum	22(°C)/ 34%RH
Test Item	30MHz-1GHz	Test Date	August 28, 2018
Polarize	Horizontal	Test Engineer	Jerry Chuang
Detector	Peak		

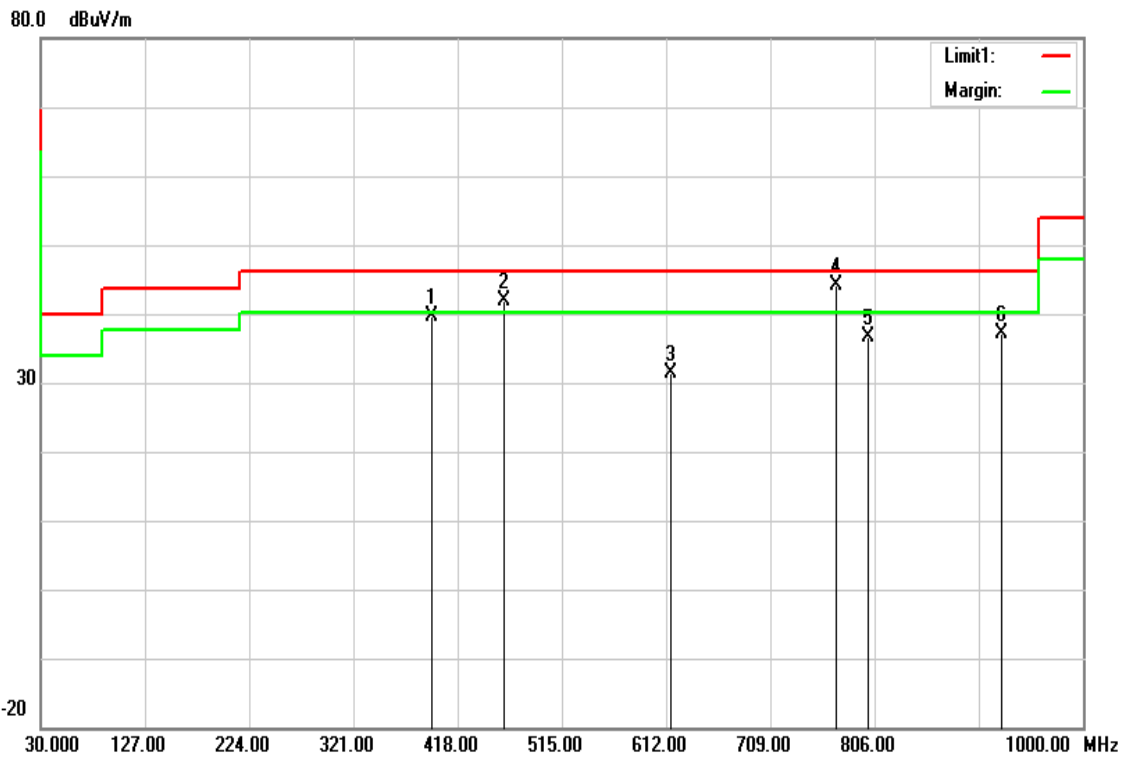

Frequency (MHz)	Reading (dBuV)	Correct Factor (dB/m)	Result (dBuV/m)	Limit (dBuV/m)	Margin (dB)	Remark
393.7500	44.59	-5.03	39.56	46.02	-6.46	QP
461.6500	44.78	-2.95	41.83	46.02	-4.19	QP
615.8800	31.57	-0.16	31.41	46.02	-14.61	peak
770.1100	41.77	2.39	44.16	46.02	-1.86	QP
800.1800	33.63	3.04	36.67	46.02	-9.35	peak
924.3400	32.11	4.91	37.02	46.02	-9.00	peak

**Note:** No emission found between lowest internal used/generated frequency to 30MHz(9KHz~30MHz)

Report No.: T180802D05-RP2

**Above 1G Test Data**

Test Mode:	BLE Low CH	Temp/Hum	22(°C)/ 34%RH
Test Item	Harmonic	Test Date	August 28, 2018
Polarize	Vertical	Test Engineer	Jerry Chuang
Detector	Peak		

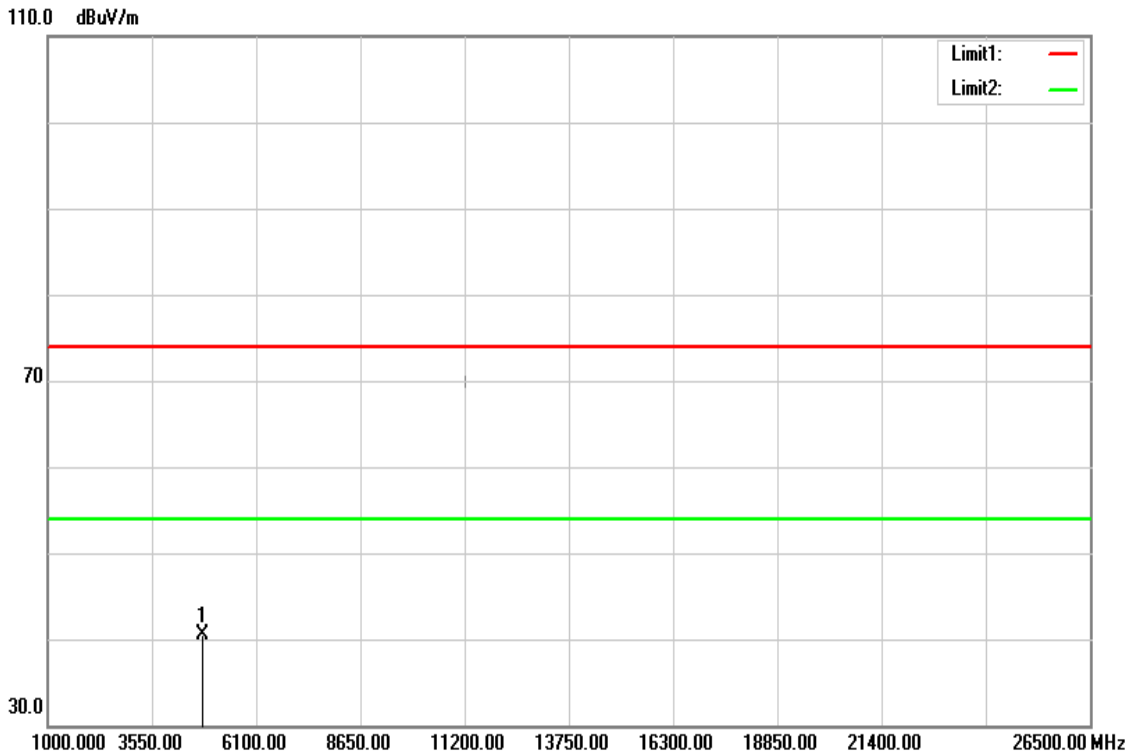

Frequency (MHz)	Reading (dBuV)	Correct Factor (dB/m)	Result (dBuV/m)	Limit (dBuV/m)	Margin (dB)	Remark
4804.000	37.35	3.09	40.44	74.00	-33.56	peak
N/A						

**Remark:**

1. Measuring frequencies from 1 GHz to the 10th harmonic of highest fundamental frequency.
2. For above 1GHz, the EUT peak value was under average limit, therefore the Average value compliance with the average limit

Report No.: T180802D05-RP2

Test Mode:	BLE Low CH	Temp/Hum	22(°C)/ 34%RH
Test Item	Harmonic	Test Date	August 28, 2018
Polarize	Horizontal	Test Engineer	Jerry Chuang
Detector	Peak		

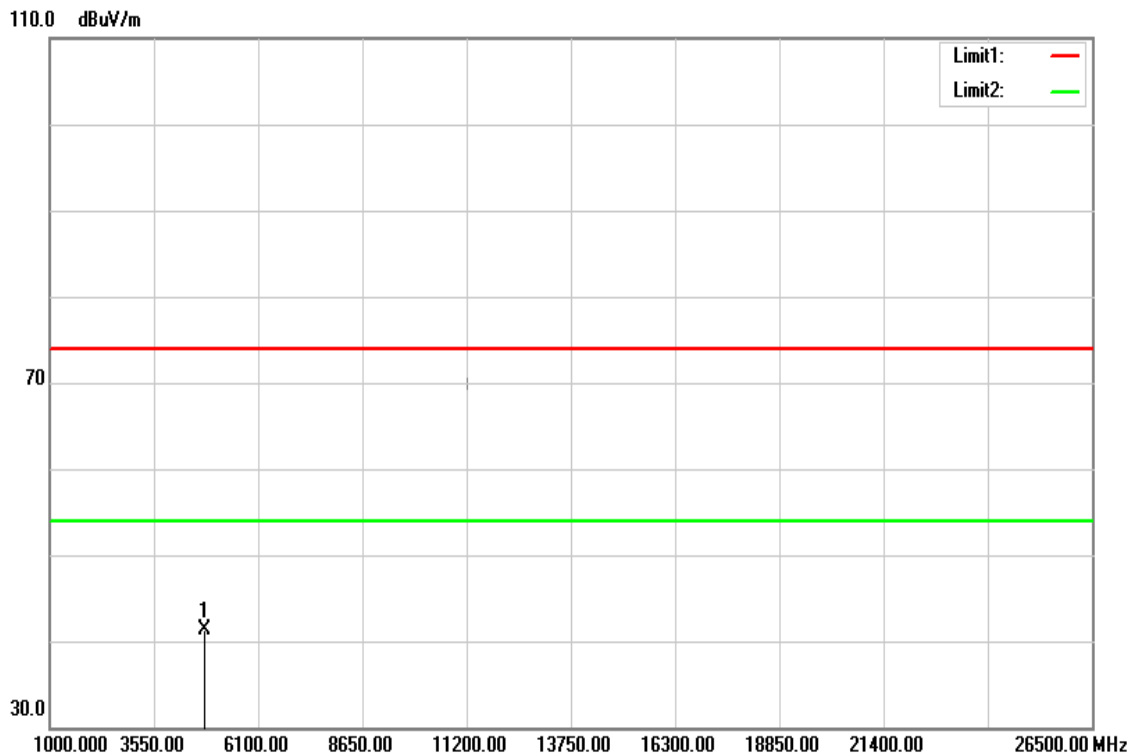

Frequency (MHz)	Reading (dBuV)	Correct Factor (dB/m)	Result (dBuV/m)	Limit (dBuV/m)	Margin (dB)	Remark
4804.000	38.21	3.09	41.30	74.00	-32.70	peak
N/A						

**Remark:**

1. Measuring frequencies from 1 GHz to the 10th harmonic of highest fundamental frequency.
2. For above 1GHz, the EUT peak value was under average limit, therefore the Average value compliance with the average limit

Report No.: T180802D05-RP2

Test Mode:	BLE Mid CH	Temp/Hum	22(°C)/ 34%RH
Test Item	Harmonic	Test Date	August 28, 2018
Polarize	Vertical	Test Engineer	Jerry Chuang
Detector	Peak		

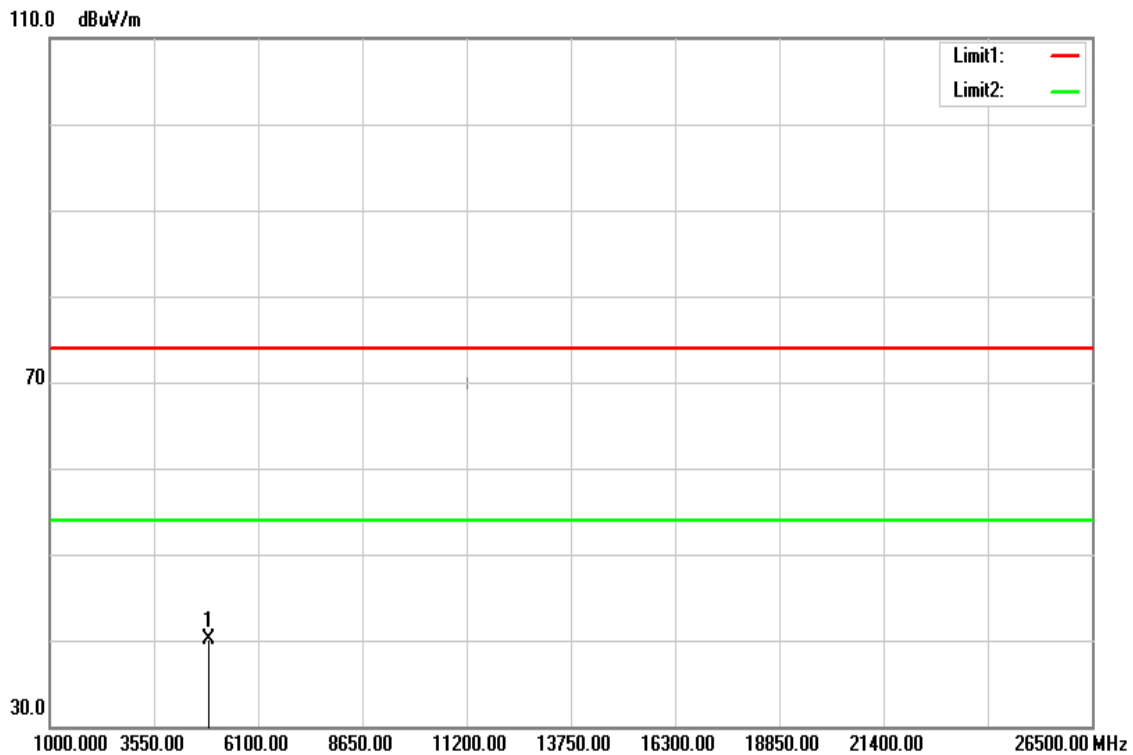

Frequency (MHz)	Reading (dBuV)	Correct Factor (dB/m)	Result (dBuV/m)	Limit (dBuV/m)	Margin (dB)	Remark
4880.000	36.58	3.60	40.18	74.00	-33.82	peak
N/A						

**Remark:**

1. Measuring frequencies from 1 GHz to the 10th harmonic of highest fundamental frequency.
2. For above 1GHz, the EUT peak value was under average limit, therefore the Average value compliance with the average limit

Report No.: T180802D05-RP2

Test Mode:	BLE Mid CH	Temp/Hum	22(°C)/ 34%RH
Test Item	Harmonic	Test Date	August 28, 2018
Polarize	Horizontal	Test Engineer	Jerry Chuang
Detector	Peak		

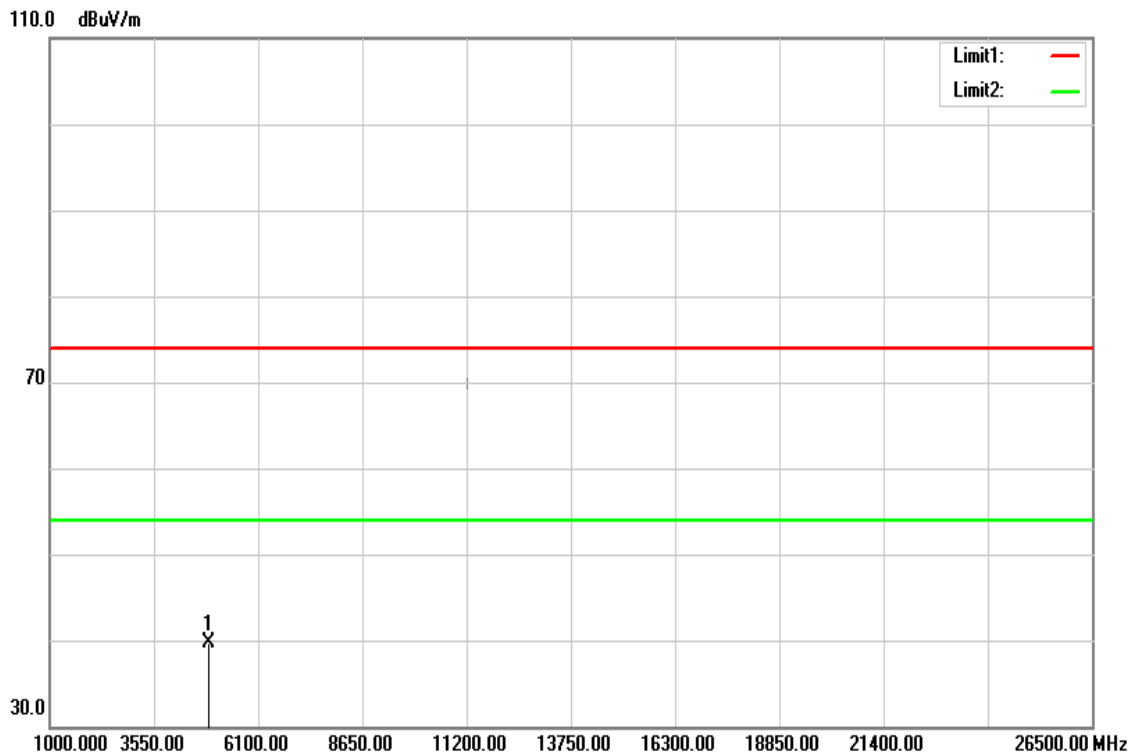

Frequency (MHz)	Reading (dBuV)	Correct Factor (dB/m)	Result (dBuV/m)	Limit (dBuV/m)	Margin (dB)	Remark
4880.000	36.10	3.60	39.70	74.00	-34.30	peak
N/A						

**Remark:**

1. Measuring frequencies from 1 GHz to the 10th harmonic of highest fundamental frequency.
2. For above 1GHz, the EUT peak value was under average limit, therefore the Average value compliance with the average limit



Report No.: T180802D05-RP2

Test Mode:	BLE High CH	Temp/Hum	22(°C)/ 34%RH
Test Item	Harmonic	Test Date	August 28, 2018
Polarize	Vertical	Test Engineer	Jerry Chuang
Detector	Peak		

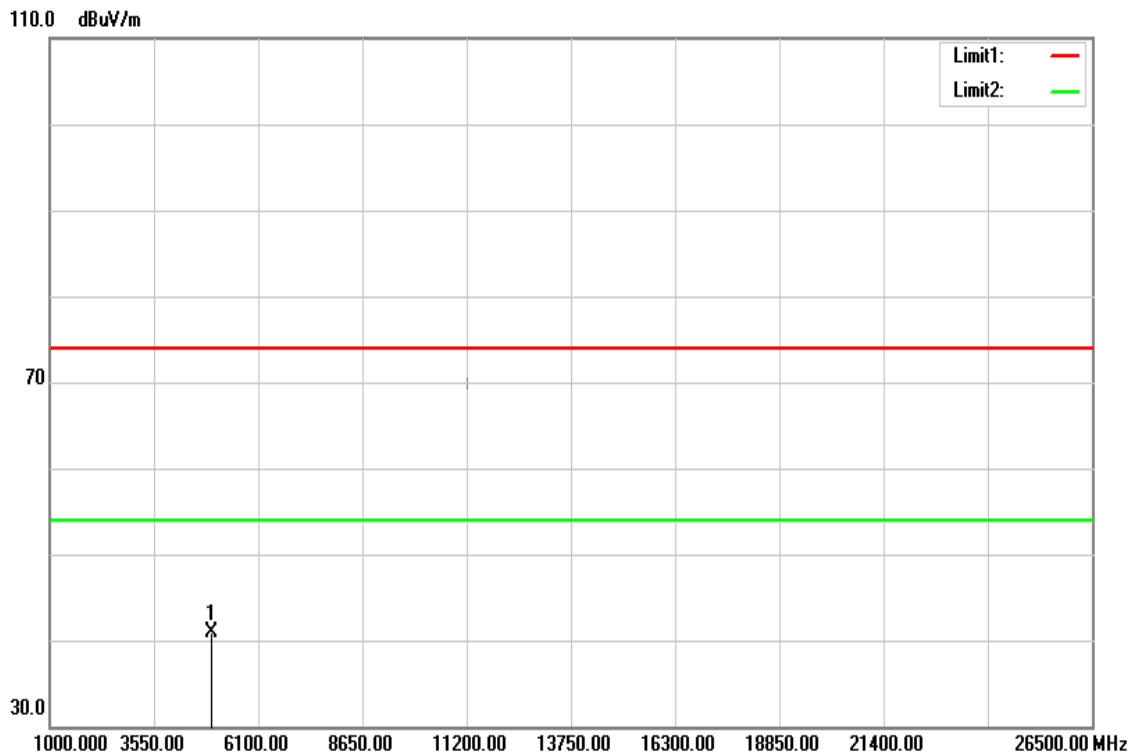

Frequency (MHz)	Reading (dBuV)	Correct Factor (dB/m)	Result (dBuV/m)	Limit (dBuV/m)	Margin (dB)	Remark
4960.000	36.81	4.14	40.95	74.00	-33.05	peak
N/A						

**Remark:**

1. Measuring frequencies from 1 GHz to the 10th harmonic of highest fundamental frequency.
2. For above 1GHz, the EUT peak value was under average limit, therefore the Average value compliance with the average limit

Report No.: T180802D05-RP2

Test Mode:	BLE High CH	Temp/Hum	22(°C)/ 34%RH
Test Item	Harmonic	Test Date	August 28, 2018
Polarize	Horizontal	Test Engineer	Jerry Chuang
Detector	Peak		

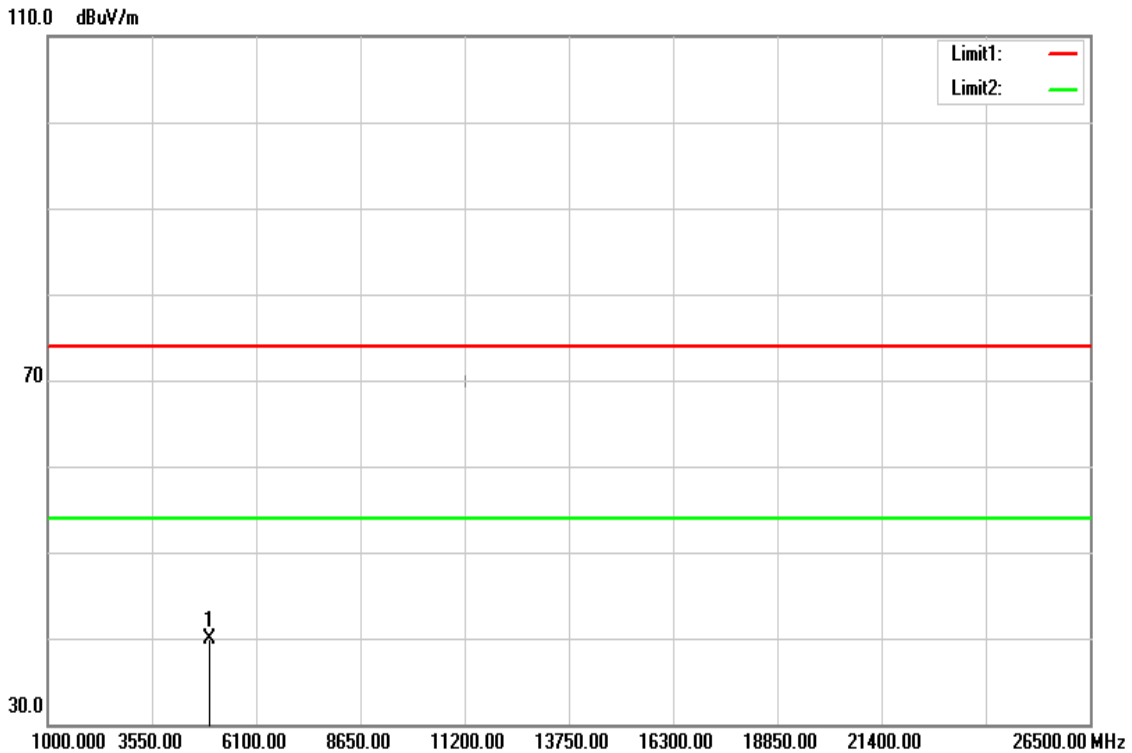

Frequency (MHz)	Reading (dBuV)	Correct Factor (dB/m)	Result (dBuV/m)	Limit (dBuV/m)	Margin (dB)	Remark
4960.000	35.86	4.14	40.00	74.00	-34.00	peak
N/A						

**Remark:**

1. Measuring frequencies from 1 GHz to the 10th harmonic of highest fundamental frequency.
2. For above 1GHz, the EUT peak value was under average limit, therefore the Average value compliance with the average limit

--End of Test Report--