

FCC Test Report

Equipment : Mobile EFT-POS
Brand Name : AEVI
Model No. : bbbcd(bbb-custom version of device, e.g. P01 for CBA specific unit, 0-9, A-Z; c-Wifi or 3G+Wifi version of device, W or G;d-0-9)
FCC ID : OHBMTPT10WBG
FCC Standard : 47 CFR FCC Part 22(H), 24(E)
WCDMA Band : II, V
GSM Band : 850, 1900
FCC Classification : PCB
Applicant : Universal Scientific Industrial Co., Ltd.
141, Lane 351, Sec.1, Taiping Road, Tsaotuen, Nantou
54261, Taiwan
Manufacturer : Universal Scientific Industrial (Shanghai)

The product sample received on May 10, 2016 and completely tested on Jun. 07, 2016. We, SPORTON, would like to declare that the tested sample has been evaluated in accordance with the procedures given in ANSI/TIA-603-D-2010, ANSI C63.4 and shown compliance with the applicable technical standards.

The test results in this report apply exclusively to the tested model / sample. Without written approval of SPORTON INTERNATIONAL INC., the test report shall not be reproduced except in full.

Reviewed by:



Kevin Liang / Assistant Manager



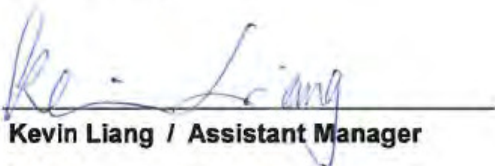

Table of Contents

1	GENERAL DESCRIPTION	5
1.1	Information.....	5
1.2	Accessories and Support Equipment	7
1.3	Testing Applied Standards	7
1.4	Testing Location Information	7
1.5	Measurement Uncertainty	8
2	TEST CONFIGURATION OF EUT.....	9
2.1	The Worst Case Measurement Configuration.....	9
2.2	Test Setup Diagram	10
3	TRANSMITTER TEST RESULT	11
3.1	Emission Bandwidth	11
3.2	Transmitter Conducted Output Power.....	15
3.3	Effective Radiated Power	19
3.4	Effective Isotropic Radiated Power	21
3.5	Transmitter Conducted Unwanted Emissions	23
3.6	Transmitter Conducted Bandedge Emissions.....	26
3.7	Transmitter Radiated Unwanted Emissions	30
3.8	Frequency Stability.....	46
4	TEST EQUIPMENT AND CALIBRATION DATA	49

APPENDIX A. TEST PHOTOS

APPENDIX B. PHOTOGRAPHS OF EUT



Summary of Test Result

Test Specifications					
Report Clause	FCC Std. Clause	Description	Measured	Limit	Result
3.1	2.1049 22.917(a) 24.238(a) 27.53(h)	Emission Bandwidth	Bandwidth GXW=244kHz G7W=249kHz F9W=4.08MHz	Information for Emission Designator	Complied
3.1.6	2.1047	Emission Designator	GXW, G7W, F9W	Information only	Complied
3.2	2.1046	Transmitter Conducted Output Power	Conducted Power [dBm] Cellular: 31.69 PCS: 28.72	Information for RF exposure	Complied
3.2.7	24.232(d) 27.50(d)	Peak to Average Ratio	3.58dB	≤13dB	Complied
3.3	22.913(a)	Effective Radiated Power (ERP)	ERP [dBm] Cellular: 29.16	≤7W[38.45dBm]	Complied
3.4	24.232(c) 27.50(d)	Effective Isotropic Radiated Power (EIRP)	EIRP [dBm] PCS:28.09	PCS: ≤2W[33.01dBm]	Complied
3.5	2.1051 22.917(a) 24.238(a) 27.53(h)	Transmitter Conducted Unwanted Emissions	refer to test data	≤43+10log(P) [-13dBm] P=TX Power in Watts	Complied
3.6	2.1051 22.917(a) 24.238(a) 27.53(h)	Transmitter Conducted Bandedge Emissions	refer to test data	≤43+10log(P) [-13dBm] P=TX Power in Watts	Complied
0	2.1053 22.917(a) 24.238(a) 27.53(h)	Transmitter Radiated Unwanted Emissions	[dBm]: 565.44MHz -38.71dBm (Margin 7.29dB)	≤43+10log(P) [-13dBm] P=TX Power in Watts	Complied
3.8	2.1055 22.355 24.353 27.54	Frequency Stability	Cellular: -0.0251ppm PCS: -0.0139ppm	±2.5ppm within band	Complied



1 General Description

1.1 Information

1.1.1 RF General Information

Function	Class/Category	
<input checked="" type="checkbox"/> GPRS	Multi-Slot Class	12
<input checked="" type="checkbox"/> EDGE	Multi-Slot Class	12
<input checked="" type="checkbox"/> HSDPA	Category	8
<input checked="" type="checkbox"/> HSUPA	Category	6

RF General Information							
Freq. Band	Mode	TX Ch. Freq. (MHz)	Channel Number	BW (MHz)	Emission Designator	Max. ERP/EIRP	
						(dBm)	(mW)
Cellular	GPRS850	824.2-848.8	128-251	0.2	244KGXW	29.16	824.14
Cellular	EDGE850	824.2-848.8	128-251	0.2	245KG7W	25.48	353.18
Cellular	WCDMA850	826.4-846.6	4132-4233	5	4M06F9W	24.22	264.24
PCS	GPRS1900	1850.2-1909.8	512-810	0.2	243KGXW	28.09	644.17
PCS	EDGE1900	1850.2-1909.8	512-810	0.2	249KG7W	24.53	283.79
PCS	WCDMA1900	1852.4-1907.6	9262-9538	5	4M08F9W	20.39	109.40

Note 1: GSM/GPRS mode consists of GMSK modulation and EDGE mode consists of 8PSK modulation.
Note 2: WCDMA Rel.99 mode consists of QPSK modulation and HSDPA Rel. 5 mode consists of QPSK and 16QAM modulation.
Note 3: WCDMA850 (WCDMA Band V), WCDMA1900 (WCDMA Band II), WCDMA1700 (WCDMA Band IV)

1.1.2 Antenna Information

Antenna Category	
<input type="checkbox"/>	Equipment placed on the market without antennas
<input checked="" type="checkbox"/>	Integral antenna (antenna permanently attached)
<input type="checkbox"/>	Temporary RF connector provided
<input checked="" type="checkbox"/>	No temporary RF connector provided Transmit chains bypass antenna and soldered temporary RF connector provided for connected measurement. In case of conducted measurements the transmitter shall be connected to the measuring equipment via a suitable attenuator and correct for all losses in the RF path.
<input type="checkbox"/>	External antenna (dedicated antennas)
<input type="checkbox"/>	RF connector provided
<input type="checkbox"/>	Unique antenna connector. (e.g., MMCX, U.FL, IPX, and RP-SMA, RP-N type...)
<input type="checkbox"/>	Standard antenna connector. (e.g., SMA, N, BNC, and TNC type...)

Antenna General Information				
Operating Band	Ant. Cat.	Ant. Type	Connector	Gain (dBi)
850/Band V	Integral	PCB	I-pex	1.58
1900/Band II	Integral	PCB	I-pex	1.70

1.1.3 Type of EUT

Identify EUT	
Presentation of Equipment	<input checked="" type="checkbox"/> Production ; <input type="checkbox"/> Pre-Production ; <input type="checkbox"/> Prototype
Type of EUT	
<input checked="" type="checkbox"/>	Stand-alone
<input type="checkbox"/>	Combined (EUT where the radio part is fully integrated within another device) Combined Equipment - Brand Name / Model No.: ...
<input type="checkbox"/>	Plug-in radio (EUT intended for a variety of host systems) Host System - Brand Name / Model No.: ...
<input type="checkbox"/>	Other:

1.1.4 EUT Operational Condition

Supply Voltage	<input checked="" type="checkbox"/> AC mains	<input checked="" type="checkbox"/> DC	
Type of DC Source	<input type="checkbox"/> Internal DC supply	<input checked="" type="checkbox"/> External AC adapter	<input checked="" type="checkbox"/> Battery
Test Voltage	<input checked="" type="checkbox"/> Vnom (7.4 V)	<input checked="" type="checkbox"/> Vmax (8.4 V)	<input checked="" type="checkbox"/> Vmin (6.0 V)
Test Climatic	<input checked="" type="checkbox"/> Tnom (20°C)	<input checked="" type="checkbox"/> Tmax (50°C)	<input checked="" type="checkbox"/> Tmin (-30°C)

1.2 Accessories and Support Equipment

Accessories

AC Adapter 1	Brand Name	AOEM	Model Name	A0605TD-120054
	Power Rating	I/P:100-240Vac, 1.8A, O/P: 12Vdc, 5.4A		
	Power Cord	0.2 meter, non-shielded cable, with w/o ferrite core		
Battery 1	Brand Name	Aaeon	Model Name	POS-5000B
	Power Rating	7.4Vdc, 4540 mAh	Type	Li-ion,NCA103450
Power Extend cable	Brand Name	AOEM	Model Name	A0605TD-120054
	Signal Line	1.5 meter, non-shielded cable, w/o ferrite core		
Singal cable	Brand Name	FLYINGWAY	Model Name	FWAA513
	Signal Line	3.1 meter, Braided-Shielded cable, with two ferrite core		

Support local

No.	Equipment	Brand	Model	FCC ID
1	NOTE BOOK	DELL	E5540	DoC
2	AC adapter for NB	DELL	LA65NS2-01	DoC

1.3 Testing Applied Standards

According to the specifications of the manufacturer, the EUT must comply with the requirements of the following standards:

- ◆ FCC Part 22(H), 24(E)
- ◆ ANSI/TIA-603-D-2010
- ◆ FCC KDB 971168 D02 v02r02
- ◆ FCC KDB 412172 D01 v01r01

1.4 Testing Location Information

Testing Location			
<input checked="" type="checkbox"/>	HWA YA	ADD :	No. 52, Hwa Ya 1st Rd., Hwa Ya Technology Park, Kwei-Shan District, Tao Yuan City, Taiwan, R.O.C.
		TEL :	886-3-327-3456 FAX : 886-3-318-0055
Test Condition	Test Site No.	Test Engineer	Test Environment
RF Conducted	TH01-HY	Howard	23.5C / 65%
Radiated Emission	03CH03-HY	Jeff	23.5°C / 57%



1.5 Measurement Uncertainty



ISO/IEC 17025 requires that an estimate of the measurement uncertainties associated with the emissions test results be included in the report. The measurement uncertainties given below are based on a 95% confidence level (based on a coverage factor (k=2))

Measurement Uncertainty		
Test Item		Uncertainty
AC power-line conducted emissions		±2.2 dB
Emission bandwidth		±1.4 %
RF output power, conducted		±0.6 dB
Unwanted emissions, conducted	30 – 1000 MHz	±0.5 dB
	1 – 18 GHz	±0.6 dB
	18 – 40 GHz	±0.8 dB
	40 – 200 GHz	N/A
All emissions, radiated	30 – 1000 MHz	±2.5 dB
	1 – 18 GHz	±3.5 dB
	18 – 40 GHz	±3.8 dB
	40 – 200 GHz	N/A
Temperature		±0.8 °C
Humidity		±3 %
DC and low frequency voltages		±3 %
Time		±1.4 %
Duty Cycle		±1.4 %

2 Test Configuration of EUT

2.1 The Worst Case Measurement Configuration

The Worst Case Mode for Following Conformance Tests	
Tests Item	Emission Bandwidth, Transmitter Conducted Output Power, Peak-Average Ratio, Transmitter Conducted Bandedge Emissions Transmitter Conducted Unwanted Emissions, Frequency Stability
Test Condition	Conducted measurement at transmit chains
Modulation Mode	GPRS, EDGE, WCDMA

The Worst Case Mode for Following Conformance Tests			
Tests Item	Effective Radiated Power (ERP) Effective Isotropic Radiated Power (EIRP) Transmitter Radiated Unwanted Emissions		
Test Condition	Radiated measurement If EUT consist of multiple antenna assembly (multiple antenna are used in EUT regardless of spatial multiplexing MIMO configuration), the radiated test should be performed with highest antenna gain of each antenna type.		
Modulation Mode	GPRS, EDGE, WCDMA		
User Position	<input type="checkbox"/> EUT will be placed in fixed position.		
	<input type="checkbox"/> EUT will be placed in mobile position and operating multiple positions. EUT shall be performed three orthogonal planes.		
	<input checked="" type="checkbox"/> EUT will be a hand-held or body-worn battery-powered devices and operating multiple positions.		
Orthogonal Planes of EUT	X Plane	Y Plane	Z Plane
			
	v		

2.2 Test Setup Diagram

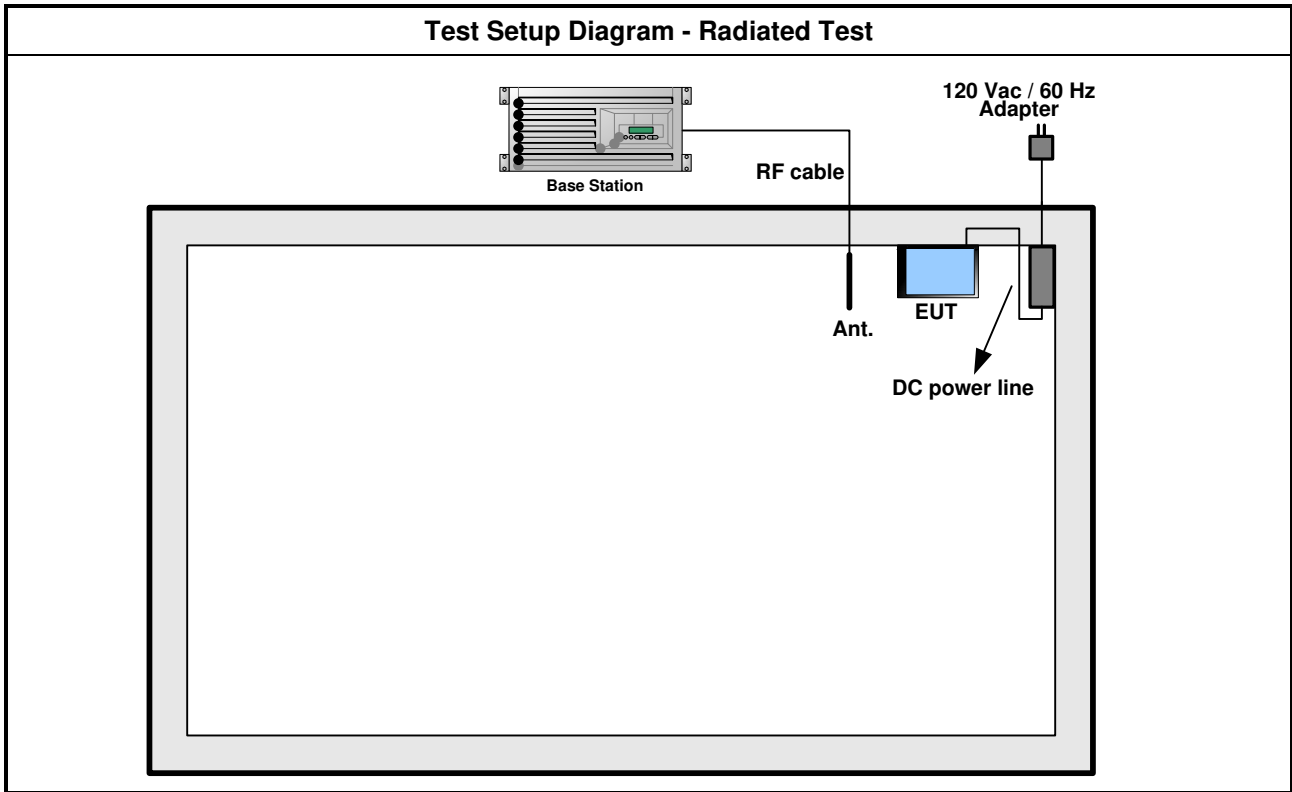

3 Transmitter Test Result

3.1 Emission Bandwidth

3.1.1 Emission Bandwidth Limit

Emission Bandwidth Limit
Information for Emission Designator.
Note 1: The 99% occupied bandwidth is the frequency bandwidth of the signal power at the 99% channel power of occupied bandwidth when resolution bandwidth should be approximately 1 % to 5 % of the span. These measurements shall also be performed at normal test conditions.

3.1.2 Measuring Instruments

Refer a test equipment and calibration data table in this test report.

3.1.3 Test Procedures

Test Method
<input checked="" type="checkbox"/> For the emission bandwidth shall be measured using one of the options below:
<input checked="" type="checkbox"/> Refer as ANSI/TIA-603-D, clause 1.3.4.4 for test bandwidth.
<input checked="" type="checkbox"/> Refer as KDB 971168 D01, clause 4 for occupied bandwidth.
<input type="checkbox"/> Refer as IC RSS-Gen, clause 4.6 for emission bandwidth.
<input checked="" type="checkbox"/> For conducted measurement.
<input checked="" type="checkbox"/> If EUT supports single transmit chain and measurements performed on this transmit chain.
<input type="checkbox"/> If EUT supports diversity transmitting and the results on transmit chain port 1 is the worst case.
<input type="checkbox"/> If EUT supports multiple transmit chains using options given below:
<input type="checkbox"/> Option 1: Multiple transmit chains measurements need to be performed on one of the active transmit chains (antenna outputs). All measurement had be performed on transmit chains 1.
<input type="checkbox"/> Option 2: Multiple transmit chains measurements need to be performed on each transmit chains individually (antenna outputs). All measurement had be performed on all transmit chains.
<input type="checkbox"/> For radiated measurement. The equipment to be measured and the test antenna shall be oriented to obtain the maximum emitted power level.

3.1.4 Test Setup

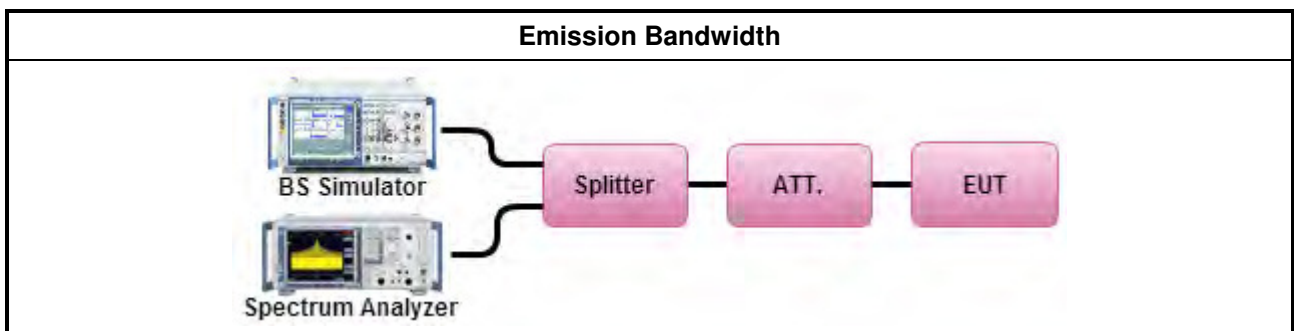



3.1.5 Test Result of Emission Bandwidth

Emission Bandwidth Result				
Mode	Ch.	Freq. (MHz)	26dB Bandwidth (MHz)	99% Bandwidth (MHz)
GPRS850	128	824.2	0.314	0.244
	189	836.4	0.319	0.243
	251	848.8	0.315	0.243
EDGE850	128	824.2	0.307	0.244
	189	836.4	0.311	0.245
	251	848.8	0.304	0.242
WCDMA 850	4132	826.4	4.631	4.063
	4182	836.4	4.623	4.064
	4233	846.6	4.636	4.069
GPRS1900	512	1850.2	0.310	0.243
	661	1880	0.315	0.243
	810	1909.8	0.316	0.243
EDGE1900	512	1850.2	0.314	0.249
	661	1880	0.313	0.247
	810	1909.8	0.307	0.248
WCDMA1900	9262	1852.4	4.691	4.088
	9400	1880	4.698	4.089
	9538	1907.6	4.704	4.086
Limit			N/A	
Result			Complied	



3.1.6 Emission Designator

Emission Designator	
Mode	Emission Designator
GPRS850	244KGXW
EDGE850	245KG7W
WCDMA850	4M06F9W
GPRS1900	243KGXW
EDGE1900	249KG7W
WCDMA1900	4M08F9W

Note 1: GPRS BW=99% BW, G=Phase Modulation, X=Cases not otherwise covered, W=Combination (Audio/Data)
Note 2: EDGE 99% BW, G=Phase Modulation, 7=Two or more channels containing digital information, W=Combination (Audio/Data)
Note 3: WCDMA 99% BW, F = Frequency Modulation, 9 = Composite Digital Info, W = Combination (Audio/Data)



Emission Bandwidth Plots

GPRS850

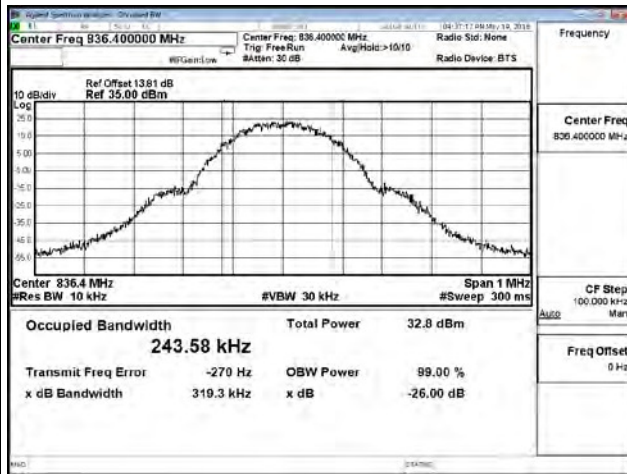

GPRS1900

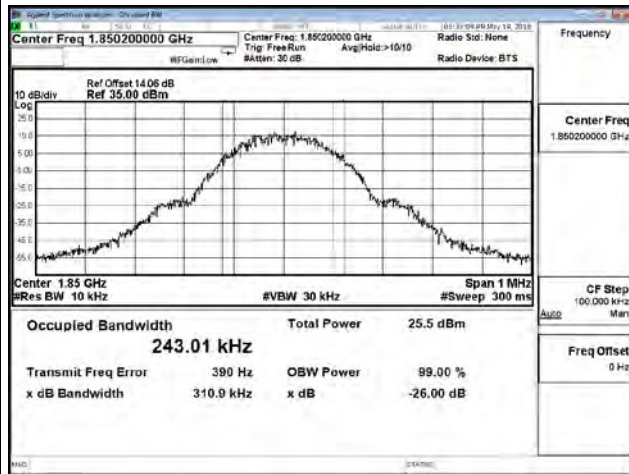

EDGE850

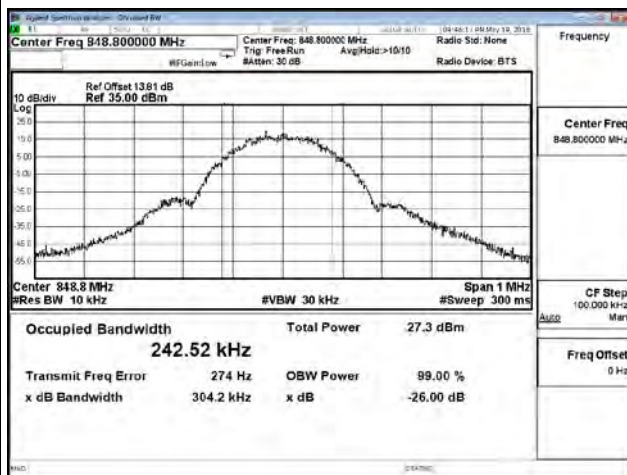

EDGE1900

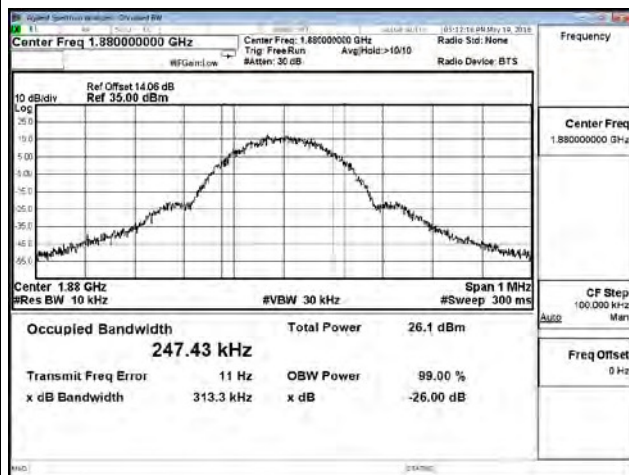

WCDMA850

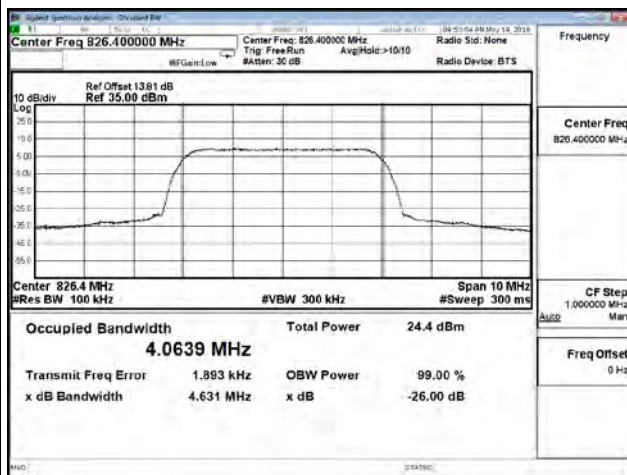

WCDMA1900

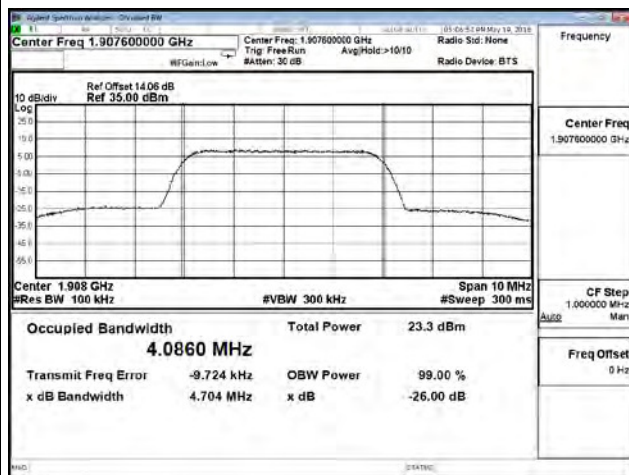

3.2 Transmitter Conducted Output Power

3.2.1 Transmitter Conducted Output Power Limit

Transmitter Conducted Output Power Limit
Information for RF exposure

3.2.2 Transmitter Peak to Average Ratio Limit

Transmitter Peak to Average Ratio Limit
PAR ≤ 13dB

3.2.3 Measuring Instruments

Refer a test equipment and calibration data table in this test report.

3.2.4 Test Procedures

Test Method	
<input checked="" type="checkbox"/>	Transmitter Conducted Output Power
<input checked="" type="checkbox"/>	Refer as FCC KDB 941225 D01 clause 5 for GSM GPRS EDGE modes.
<input type="checkbox"/>	Refer as FCC KDB 941225 D01 clause 5 for GSM/(E)GPRS Dual Transfer Mode.
<input checked="" type="checkbox"/>	Refer as FCC KDB 941225 D01 clause 4 for 3G device modes.
<input checked="" type="checkbox"/>	Refer as FCC KDB 941225 D01 clause 4 for 3GPP R6, R7 additional information.
<input type="checkbox"/>	Refer as FCC KDB 941225 D05 for LTE modes.
<input type="checkbox"/>	Refer as RSS-Gen, clause 4.8 for power measurement.
<input checked="" type="checkbox"/>	Transmitter Peak-Average Ratio
<input checked="" type="checkbox"/>	For WCDMA signals refer as KDB 971168, clause 5.7 for CCDF function.
<input checked="" type="checkbox"/>	For GSM signals refer average and a peak trace are used on a spectrum analyzer to determine the largest deviation between the average and the peak power.
<input checked="" type="checkbox"/>	For conducted measurement.
<input checked="" type="checkbox"/>	If EUT supports single transmit chain and measurements performed on this transmit chain.
<input type="checkbox"/>	If EUT supports diversity transmitting and the results on transmit chain port 1 is the worst case.
<input type="checkbox"/>	If EUT supports multiple transmit chains using options given below: Refer as FCC KDB 662911, In-band power measurements. Using the measure-and-sum approach, measured all transmit ports individually. Sum the power (in linear power units e.g., mW) of all ports for each individual sample and save them.

3.2.5 Test Setup

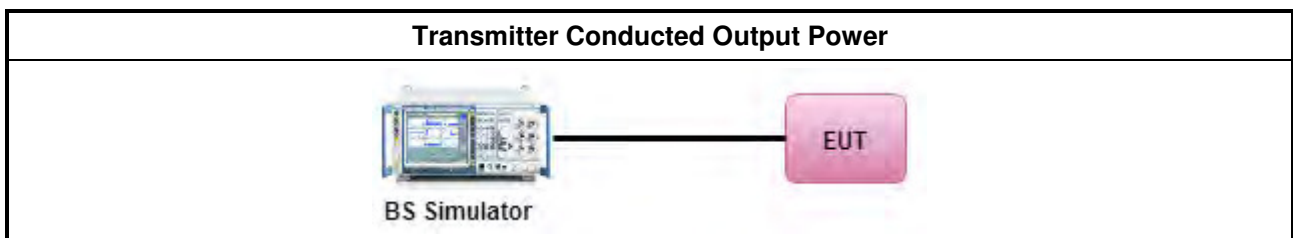



3.2.6 Test Result of Transmitter Conducted Output Power

GSM/GPRS/EDGE Worst Modulation for Output Power	
Mode Class	
GPRS Multi-slot Class	12 (max 4 Tx Uplink slots)
EDGE Multi-slot Class	12 (max 4 Tx Uplink slots)

Band	GPRS/EDGE 850			GPRS/EDGE 1900		
	Channel	128	189	251	512	661
Frequency (MHz)	824.2	836.4	848.8	1850.2	1880	1909.8
GPRS 8(1TX Slot)	31.69	31.57	31.52	28.41	28.57	28.72
GPRS 10(2TX Slot)	28.74	28.59	28.52	25.48	25.62	25.76
GPRS 11(3TX Slot)	26.96	26.81	26.73	23.69	23.83	23.97
GPRS 12(4TX Slot)	25.84	25.69	25.60	22.44	22.61	22.77
EDGE 8(1TX Slot)	25.85	25.70	25.59	24.27	24.38	24.54
EDGE 10(2TX Slot)	22.86	22.77	22.66	21.23	21.42	21.55
EDGE 11(3TX Slot)	21.08	20.99	20.89	19.37	19.56	19.72
EDGE 12(1TX Slot)	19.97	19.84	19.78	18.19	18.36	18.52

Source-Based Time-Averaged Power						
Band	GPRS/EDGE 850			GPRS/EDGE 1900		
	Channel	128	189	251	512	661
Frequency (MHz)	824.2	836.4	848.8	1850.2	1880	1909.8
GPRS 8(1TX Slot)	22.69	22.57	22.52	19.41	19.57	19.72
GPRS 10(2TX Slot)	22.74	22.59	22.52	19.48	19.62	19.76
GPRS 11(3TX Slot)	22.70	22.55	22.47	19.43	19.57	19.71
GPRS 12(4TX Slot)	22.84	22.69	22.60	19.44	19.61	19.77
EDGE 8(1TX Slot)	16.85	16.70	16.59	15.27	15.38	15.54
EDGE 10(2TX Slot)	16.86	16.77	16.66	15.23	15.42	15.55
EDGE 11(3TX Slot)	16.82	16.73	16.63	15.11	15.30	15.46
EDGE 12(1TX Slot)	16.97	16.84	16.78	15.19	15.36	15.52



WCDMA Worst Modulation for Output Power		
3GPP Release Ver.	Mode	Configuration
99	WCDMA	12.2kbps RMC
5	HSDPA	Subtest 1 ~ Subtest 4
5	HSUPA	Subtest 1 ~ Subtest 5

Mode	Subtest	RF Output Power [dBm]						MPR [dB]
		Band V (Cellular)			Band II (PCS)			
		4132	4182	4233	9262	9400	9538	
WCDMA	12.2 kbps RMC	23.32	22.80	23.13	22.39	22.84	22.24	-
HSDPA	Subtest 1	23.27	22.78	23.12	21.70	22.09	21.77	0
	Subtest 2	22.51	22.07	22.39	21.17	21.57	21.24	0
	Subtest 3	22.27	21.79	22.13	21.05	21.42	21.10	0.5
	Subtest 4	22.02	21.53	21.86	20.77	21.14	20.81	0.5
HSUPA	Subtest 1	21.37	21.06	21.36	20.72	21.03	20.82	0
	Subtest 2	20.61	20.16	20.49	19.65	20.06	19.77	2
	Subtest 3	21.27	20.91	21.25	20.57	20.93	20.70	1
	Subtest 4	20.82	20.38	20.71	19.90	20.29	20.04	2
	Subtest 5	20.67	20.47	20.69	20.78	20.57	20.51	0



3.2.7 Test Result of Transmitter Peak to Average Ratio

Transmitter Peak to Average Ratio Result			
Mode	Ch.	Freq. (MHz)	Peak to Average Ratio (dB)
GPRS850	189	836.4	0.23
EDGE850	189	836.4	3.31
WCDMA850	4182	836.4	3.58
GPRS1900	810	1909.8	0.15
EDGE1900	810	1909.8	3.27
WCDMA1900	9262	1852.4	2.83
Limit			13
Result			Complied

3.3 Effective Radiated Power

3.3.1 Effective Radiated Power Limit

Cellular Band Effective Radiated Power (ERP) Limit
ERP ≤ 7W [38.45dBm] (EIRP 40.6dBm [135.8 dBuV/m at 3m]).

3.3.2 Measuring Instruments

Refer a test equipment and calibration data table in this test report.

3.3.3 Test Procedures

Test Method	
<input checked="" type="checkbox"/>	For wideband (> 1 MHz) digital transmission systems power measure following as KDB 971168.
<input checked="" type="checkbox"/>	Effective Radiated Power (ERP)
<input checked="" type="checkbox"/>	Refer as KDB 412172, clause 1.3.2 following as power approach. e.i.r.p.= P _T +G _T .
<input type="checkbox"/>	Refer as KDB 412172, clause 1.3.1 following as field strength approach. e.i.r.p.= (E x d) ² / 30.
<input checked="" type="checkbox"/>	Refer as KDB 412172, clause 1.4.4 ERP = EIRP - 2.15 dB.
<input type="checkbox"/>	For radiated measurement.
<input type="checkbox"/>	Refer as KDB 412172, clause 2.2 following eirp can be used radiated test configuration.
<input type="checkbox"/>	Refer as KDB 412172, clause 5 following eirp can be directly determined using the field strength.
<input type="checkbox"/>	Refer as KDB 412172, clause 6 following eirp can be used signal/antenna substitution techniques.
<input checked="" type="checkbox"/>	Refer as ANSI/TIA-603-D-2010, clause 2.2.17 for radiated measurement.
<input checked="" type="checkbox"/>	Refer as RSS-Gen, clause 4.8 for power measurement.

3.3.4 Test Setup

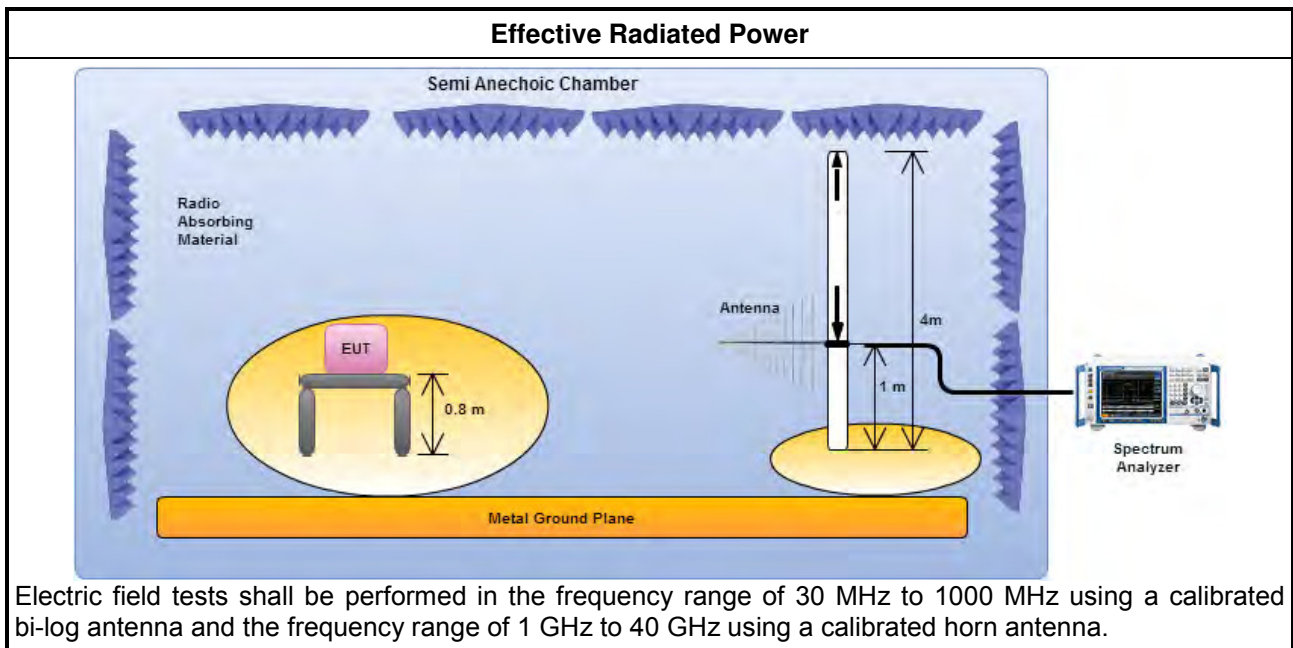



3.3.5 Test Result of Effective Radiated Power

Mode	Channel	Frequency (MHz)	ERP(dBm)	SPA. Reading (dBm)	S.G. Power (dBm)	TX Cable loss (dB)	TX Antenna Gain (dBi)	Polarization (H/V)
GPRS850	128	824.2	28.20	-8.98	22.74	0.25	7.86	H
	189	836.4	29.16	-8.44	23.47	0.25	8.09	H
	251	848.8	29.05	-8.85	23.12	0.25	8.33	H
EDGE850	128	824.2	24.49	-12.69	19.03	0.25	7.86	H
	189	836.4	25.10	-12.50	19.41	0.25	8.09	H
	251	848.8	25.48	-12.42	19.55	0.25	8.33	H

Note 1: EUT was tested in all GPRS/EDGE configurations and the highest power is reported in 1 Tx Slot GPRS mode.

Note 2: EUT was tested with its standard battery.

Note 3: Measurement worst emissions of receive antenna polarization.

Note 4: ERP [dBm] = E-Field [dBuV/m] - 95.2 - 2.15; E-Field [dBuV/m] = Raw [dBuV] + Factor [dB]

Mode	Channel	Frequency (MHz)	ERP(dBm)	SPA. Reading (dBm)	S.G. Power (dBm)	TX Cable loss (dB)	TX Antenna Gain (dBi)	Polarization (H/V)
WCDMA850	4132	826.4	23.16	-14.08	17.66	0.25	7.9	H
	4182	836.4	23.49	-14.11	17.80	0.25	8.09	H
	4233	846.6	24.22	-13.47	18.33	0.25	8.29	H

Note 1: EUT was tested in all WCDMA/HSDPA configurations and the highest power is reported in 12.2 kbps RMC and TPC bits all set "1".

Note 2: EUT was tested with its standard battery.

Note 3: Measurement worst emissions of receive antenna polarization.

Note 4: ERP [dBm] = E-Field [dBuV/m] - 95.2 - 2.15; E-Field [dBuV/m] = Raw [dBuV] + Factor [dB]

3.4 Effective Isotropic Radiated Power

3.4.1 Effective Isotropic Radiated Power Limit

PCS Band and AWS Band Effective Isotropic Radiated Power (EIRP) Limit
PCS Band: EIRP ≤ 2W [33.01dBm] (128.2 dBuV/m at 3m)
AWS Band: EIRP ≤ 1W [30.00dBm] (125.2 dBuV/m at 3m)

3.4.2 Measuring Instruments

Refer a test equipment and calibration data table in this test report.

3.4.3 Test Procedures

Test Method	
<input checked="" type="checkbox"/>	For wideband (> 1 MHz) digital transmission systems power measure following as KDB 971168.
<input checked="" type="checkbox"/>	Effective Isotropic Radiated Power (EIRP)
<input checked="" type="checkbox"/>	Refer as KDB 412172, clause 1.3.2 following as power approach. e.i.r.p.= P _T +G _T .
<input type="checkbox"/>	Refer as KDB 412172, clause 1.3.1 following as field strength approach. e.i.r.p.= (E x d) ² / 30.
<input type="checkbox"/>	For radiated measurement.
<input type="checkbox"/>	Refer as KDB 412172, clause 2.2 following eirp can be used radiated test configuration.
<input type="checkbox"/>	Refer as KDB 412172, clause 5 following eirp can be directly determined using the field strength.
<input type="checkbox"/>	Refer as KDB 412172, clause 6 following eirp can be used signal/antenna substitution techniques.
<input checked="" type="checkbox"/>	Refer as ANSI/TIA-603-D-2010, clause 2.2.17 for radiated measurement.
<input type="checkbox"/>	Refer as RSS-Gen, clause 4.8 for power measurement.

3.4.4 Test Setup

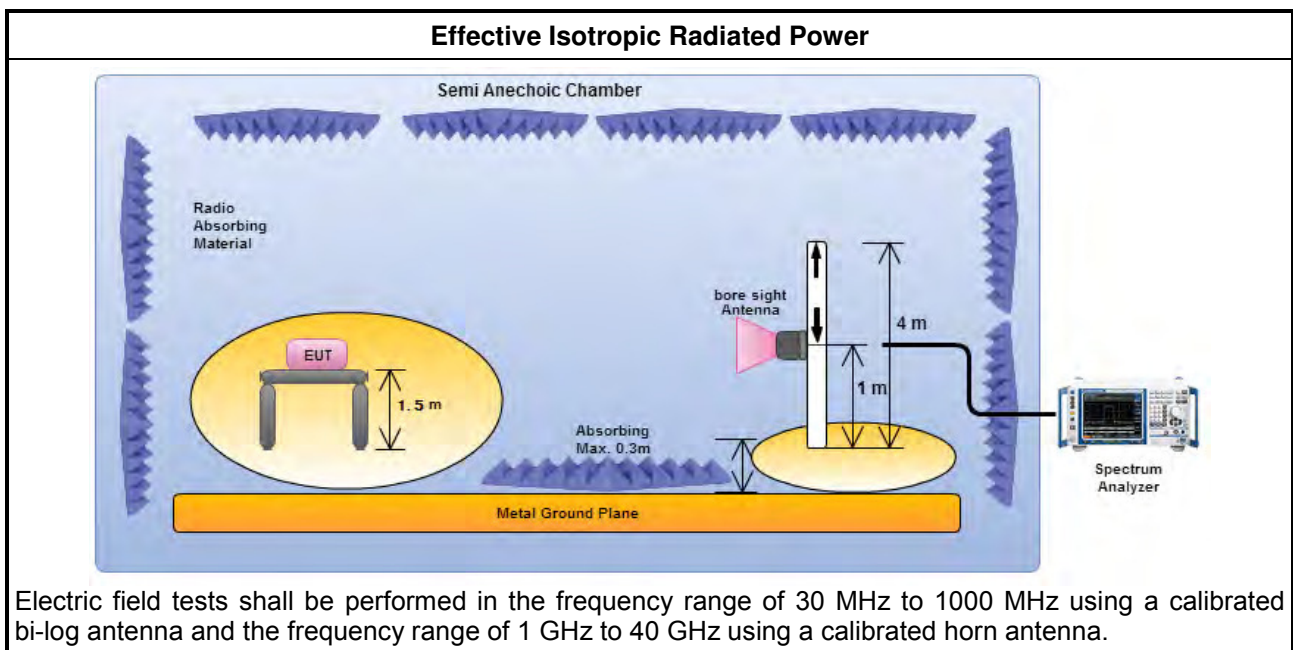



3.4.5 Test Result of Effective Isotropic Radiated Power

Mode	Channel	EIRP(dBm)	SPA Reading (dBm)	S.G. Power (dBm)	TX Cable loss (dB)	TX Antenna Gain (dBi)	EIRP(dBm)	Polarization (H/V)
GPRS1900	512	28.09	-11.37	26.15	2.57	4.51	28.09	H
	661	26.98	-11.88	25.17	2.60	4.41	26.98	H
	810	26.74	-12.02	25.03	2.60	4.31	26.74	H
EDGE1900	512	24.53	-14.93	22.59	2.57	4.51	24.53	H
	661	23.93	-14.93	22.12	2.60	4.41	23.93	H
	810	23.95	-14.81	22.24	2.60	4.31	23.95	H

Note 1: EUT was tested in all GPRS/EDGE configurations and the highest power is reported in 1 Tx Slot GPRS mode.

Note 2: EUT was tested with its standard battery.

Note 3: Measurement worst emissions of receive antenna polarization.

Note 4: $EIRP [dBm] = E\text{-Field [dBuV/m]} - 95.2$; $E\text{-Field [dBuV/m]} = Raw [dBuV] + Factor [dB]$

Mode	Channel	Frequency (MHz)	EIRP(dBm)	SPA Reading (dBm)	S.G. Power (dBm)	TX Cable loss (dB)	TX Antenna Gain (dBi)	Polarization (H/V)
WCDMA1900	9262	1852.4	20.39	-18.27	18.46	2.57	4.50	H
	9400	1880.0	20.01	-18.85	18.20	2.60	4.41	H
	9538	1907.6	19.55	-19.14	17.84	2.60	4.31	H

Note 1: EUT was tested in all WCDMA/HSDPA configurations and the highest power is reported in 12.2 kbps RMC and TPC bits all set "1".

Note 2: EUT was tested with its standard battery.

Note 3: Measurement worst emissions of receive antenna polarization.

Note 4: $EIRP [dBm] = E\text{-Field [dBuV/m]} - 95.2$; $E\text{-Field [dBuV/m]} = Raw [dBuV] + Factor [dB]$

3.5 Transmitter Conducted Unwanted Emissions

3.5.1 Transmitter Conducted Unwanted Emissions Limit

Transmitter Conducted Unwanted Emissions Limit
The power of any emission outside a licensee's frequency band(s) of operation shall be attenuated below the transmitter power (P) within the licensed band(s) of operation, measured in watts, by at least $[43 + 10 \log(P)]$ (-13dBm).

3.5.2 Measuring Instruments

Refer a test equipment and calibration data table in this test report.

3.5.3 Test Procedures

Test Method		
<input checked="" type="checkbox"/> Refer as ANSI/TIA-603-D-2010, clause 3.2.13 for conducted measurement.		
<input type="checkbox"/> Refer as RSS-Gen, clause 4.9 for transmitter unwanted emissions measurement.		
<input type="checkbox"/> In case a narrower measurement bandwidth was used, the following conversion formula has to be applied: (e.g. if reference bandwidth 1 MHz and measurement bandwidth 100 kHz, then measurement bandwidth conversion factor is 10 dB); $B = A + 10 \log(BW_{ref} / BW_{measured})$ <ul style="list-style-type: none"> • A is the value at the narrower measurement bandwidth; • B is the value referred to the reference bandwidth; • Correction Factor(dB)= $10\log(1\% \text{ Emission BW/RBW})$; 		
<input checked="" type="checkbox"/> For conducted measurement.		
<input checked="" type="checkbox"/> For conducted measurements on devices with single transmit chain. <input type="checkbox"/> For conducted measurements on devices with multiple transmit chains using options given below: <table border="1" style="margin-left: 20px;"> <tr> <td><input type="checkbox"/> Option 1: measure and sum the spectra across the transmitter outputs.</td> </tr> <tr> <td><input type="checkbox"/> Option 2: N transmitter outputs, then spurious emissions limits on each individual output. Measure and add $10 \log(N)$ dB.</td> </tr> </table>	<input type="checkbox"/> Option 1: measure and sum the spectra across the transmitter outputs.	<input type="checkbox"/> Option 2: N transmitter outputs, then spurious emissions limits on each individual output. Measure and add $10 \log(N)$ dB.
<input type="checkbox"/> Option 1: measure and sum the spectra across the transmitter outputs.		
<input type="checkbox"/> Option 2: N transmitter outputs, then spurious emissions limits on each individual output. Measure and add $10 \log(N)$ dB.		

3.5.4 Test Setup

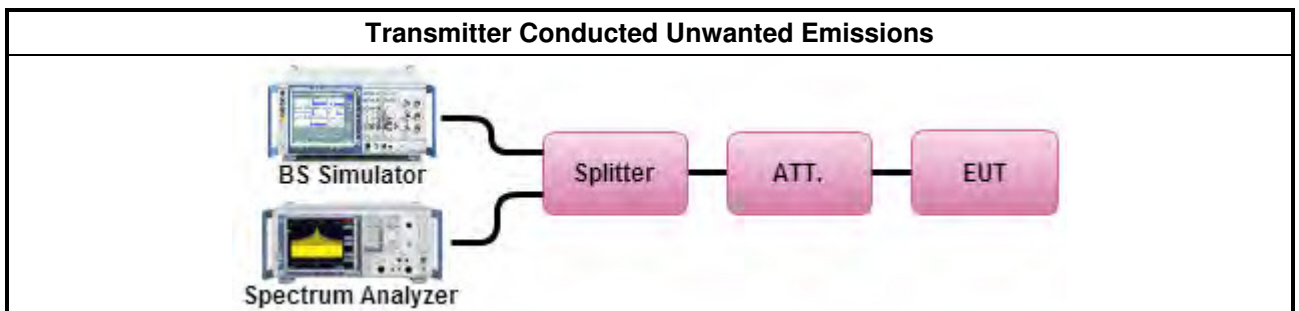



3.5.5 Test Result of Transmitter Conducted Unwanted Emissions

Transmitter Conducted Unwanted Emissions		Test Range	30 MHz - 10 harmonic
Mode / Channel	GPRS850 / 189	Mode / Channel	EDGE850 / 189
Mode / Channel	WCDMA850 / 4182		



Transmitter Conducted Unwanted Emissions		Test Range	30 MHz - 10 harmonic
Mode / Channel	GPRS1900 / 661	Mode / Channel	EDGE1900 / 661
Mode / Channel		WCDMA1900 / 9400	

3.6 Transmitter Conducted Bandedge Emissions

3.6.1 Transmitter Conducted Bandedge Emissions Limit

Transmitter Conducted Bandedge Emissions Limit
<p>Cellular Band:</p> <p>(i) In the first 1.0 MHz band immediately outside frequency block, the power of emissions per any 1% of the emission bandwidth shall be attenuated (in dB) below the transmitter output power P (dBW) by at least $43 + 10 \log(P)$ (watts) (-13dBm).</p> <p>(ii) After the first 1.0 MHz immediately outside frequency block, the power of emissions in any 100 kHz bandwidth shall be attenuated (in dB) below the transmitter output power P (dBW) by at least $43 + 10 \log(P)$ (watts) (-13dBm). If the measurement is performed using 1% of the emission bandwidth, power integration over 100 kHz is required.</p> <p>PCS/AWS Band:</p> <p>(i) In the 1.0 MHz bands immediately outside frequency block, the emission power per any 1% of the emission bandwidth shall be attenuated (in dB) below the transmitter output power P (dBW) by at least $43 + 10 \log(P)$ (watts) (-13dBm).</p> <p>(ii) After the first 1.0 MHz immediately outside frequency block, the power of emissions in any 1 MHz bandwidth shall be attenuated (in dB) below the transmitter output power P (dBW) by at least $43 + 10 \log(P)$ (watts) (-13dBm). If the measurement is performed using 1% of the occupied bandwidth, power integration over 1 MHz is required.</p>

3.6.2 Measuring Instruments

Refer a test equipment and calibration data table in this test report.

3.6.3 Test Procedures

Test Method	
<input checked="" type="checkbox"/>	Refer as ANSI/TIA-603-D-2010, clause 3.2.13 for conducted measurement.
<input type="checkbox"/>	Refer as RSS-Gen, clause 4.9 for transmitter unwanted emissions measurement.
<input checked="" type="checkbox"/>	<p>In case a narrower measurement bandwidth was used, the following conversion formula has to be applied: (e.g. if reference bandwidth 1 MHz and measurement bandwidth 100 kHz, then measurement bandwidth conversion factor is 10 dB); $B = A + 10 \log (BW_{ref} / BW_{measured})$</p> <ul style="list-style-type: none"> • A is the value at the narrower measurement bandwidth; • B is the value referred to the reference bandwidth; • Correction Factor(dB)= $10\log(1\% \text{ Emission BW/RBW})$;
<input checked="" type="checkbox"/>	For conducted measurement.
<input checked="" type="checkbox"/>	For conducted measurements on devices with single transmit chain.
<input type="checkbox"/>	For conducted measurements on devices with multiple transmit chains using options given below:
<input type="checkbox"/>	Option 1: measure and sum the spectra across the transmitter outputs.
<input type="checkbox"/>	Option 2: N transmitter outputs, then spurious emissions limits on each individual output. Measure and add $10 \log (N)$ dB.

3.6.4 Test Setup

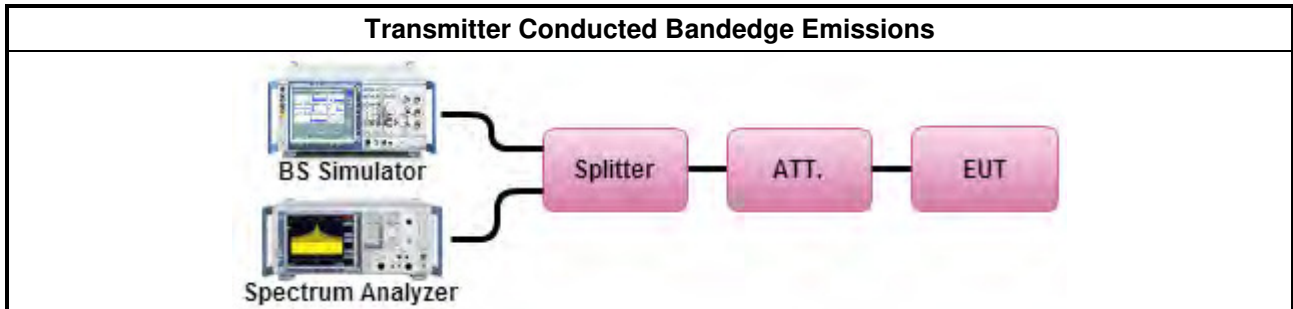



3.6.5 Test Result of Transmitter Conducted Bandedge Emissions

<p style="text-align: center;">Transmitter Conducted Bandedge Emissions</p>	<p style="text-align: center;">Mode/Channel GPRS850/(128,251)</p>
<p style="text-align: center;">Transmitter Conducted Bandedge Emissions</p>	<p style="text-align: center;">Mode/Channel EDGE850/(128,251)</p>
<p style="text-align: center;">Transmitter Conducted Bandedge Emissions</p>	<p style="text-align: center;">Mode/Channel WCDMA850/(4132,4233)</p>



<p>Transmitter Conducted Bandedge Emissions</p>	<p>Mode/Channel GPRS1900/(512,810)</p>
<p>Transmitter Conducted Bandedge Emissions</p>	<p>Mode/Channel EDGE1900/(512,810)</p>
<p>Transmitter Conducted Bandedge Emissions</p>	<p>Mode/Channel WCDMA1900/(9262,9538)</p>



3.7 Transmitter Radiated Unwanted Emissions

3.7.1 Transmitter Radiated Unwanted Emissions Limit

Transmitter Radiated Unwanted Emissions Limit
The power of any emission outside a licensee's frequency band(s) of operation shall be attenuated below the transmitter power (P) within the licensed band(s) of operation, measured in watts, by at least $[43 + 10 \log (P)]$ (EIRP -13dBm).

3.7.2 Measuring Instruments

Refer a test equipment and calibration data table in this test report.

3.7.3 Test Procedures

Test Method	
<input checked="" type="checkbox"/>	Refer as ANSI/TIA-603-D-2010, clause 3.2.12 for radiated measurement.
<input type="checkbox"/>	Refer as RSS-Gen, clause 4.9 for transmitter unwanted emissions measurement.
<input type="checkbox"/>	In case a narrower measurement bandwidth was used, the following conversion formula has to be applied: (e.g. if reference bandwidth 1 MHz and measurement bandwidth 100 kHz, then measurement bandwidth conversion factor is 10 dB) $B = A + 10 \log (BW_{ref} / BW_{measured})$ <ul style="list-style-type: none"> • A is the value at the narrower measurement bandwidth; • B is the value referred to the reference bandwidth; • Correction Factor(dB)= $10\log(1\% \text{ Emission BW/RBW})$;
<input checked="" type="checkbox"/>	Effective Isotropic Radiated Power (EIRP)
<input type="checkbox"/>	Refer as KDB 412172, clause 1.3.2 following as power approach. $e.i.r.p. = P_T + G_T$.
<input checked="" type="checkbox"/>	Refer as KDB 412172, clause 1.3.1 following as field strength approach. $e.i.r.p. = (E \times d)^2 / 30$.
<input type="checkbox"/>	For radiated measurement.
<input type="checkbox"/>	Refer as KDB 412172, clause 2.2 following eirp can be used radiated test configuration.
<input checked="" type="checkbox"/>	Refer as KDB 412172, clause 5 following eirp can be directly determined using the field strength.
<input type="checkbox"/>	Refer as KDB 412172, clause 6 following eirp can be used signal/antenna substitution techniques.
<input type="checkbox"/>	Refer as ANSI/TIA-603-D-2010, clause 2.2.12 for radiated measurement.

3.7.4 Test Setup

Transmitter Radiated Unwanted Emissions (below 1GHz)

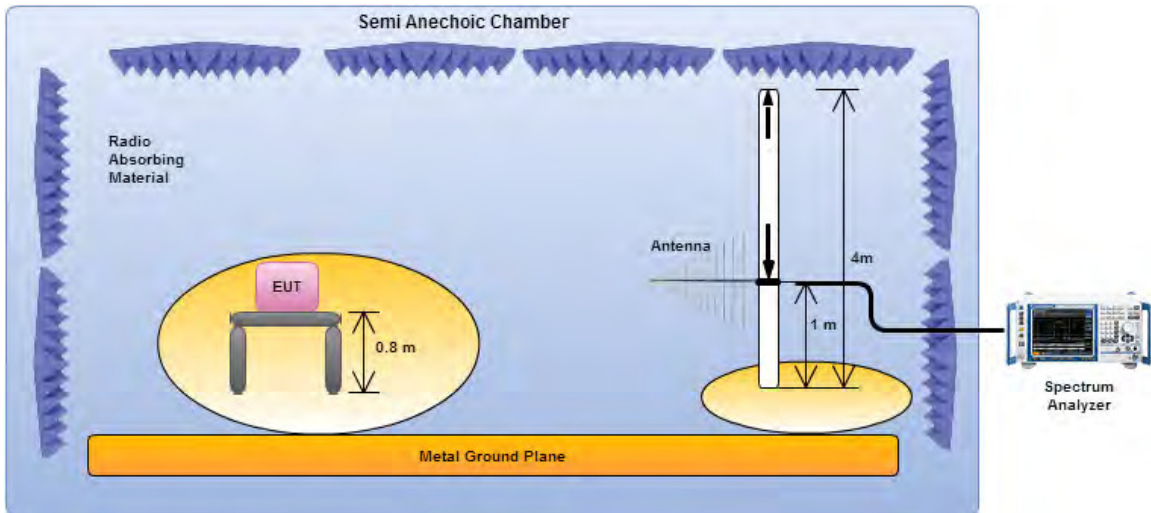

Electric field tests shall be performed in the frequency range of 1 GHz to 10th harmonic of highest fundamental frequency or 40 GHz using a calibrated horn antenna

Transmitter Radiated Unwanted Emissions (Above 1GHz)

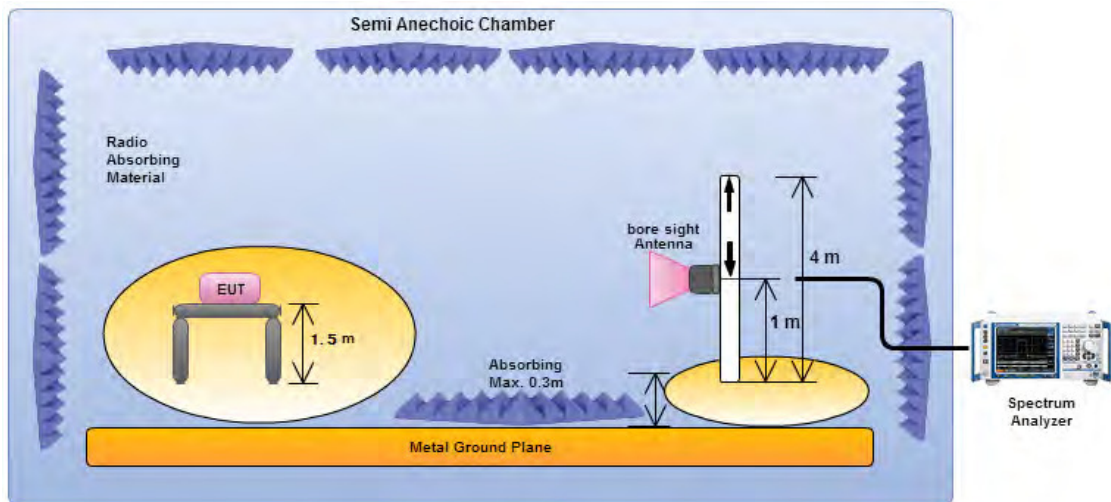

Electric field tests shall be performed in the frequency range of 1 GHz to 10th harmonic of highest fundamental frequency or 40 GHz using a calibrated horn antenna.



3.7.5 Test Result of Transmitter Radiated Unwanted Emissions(Below 1GHz)

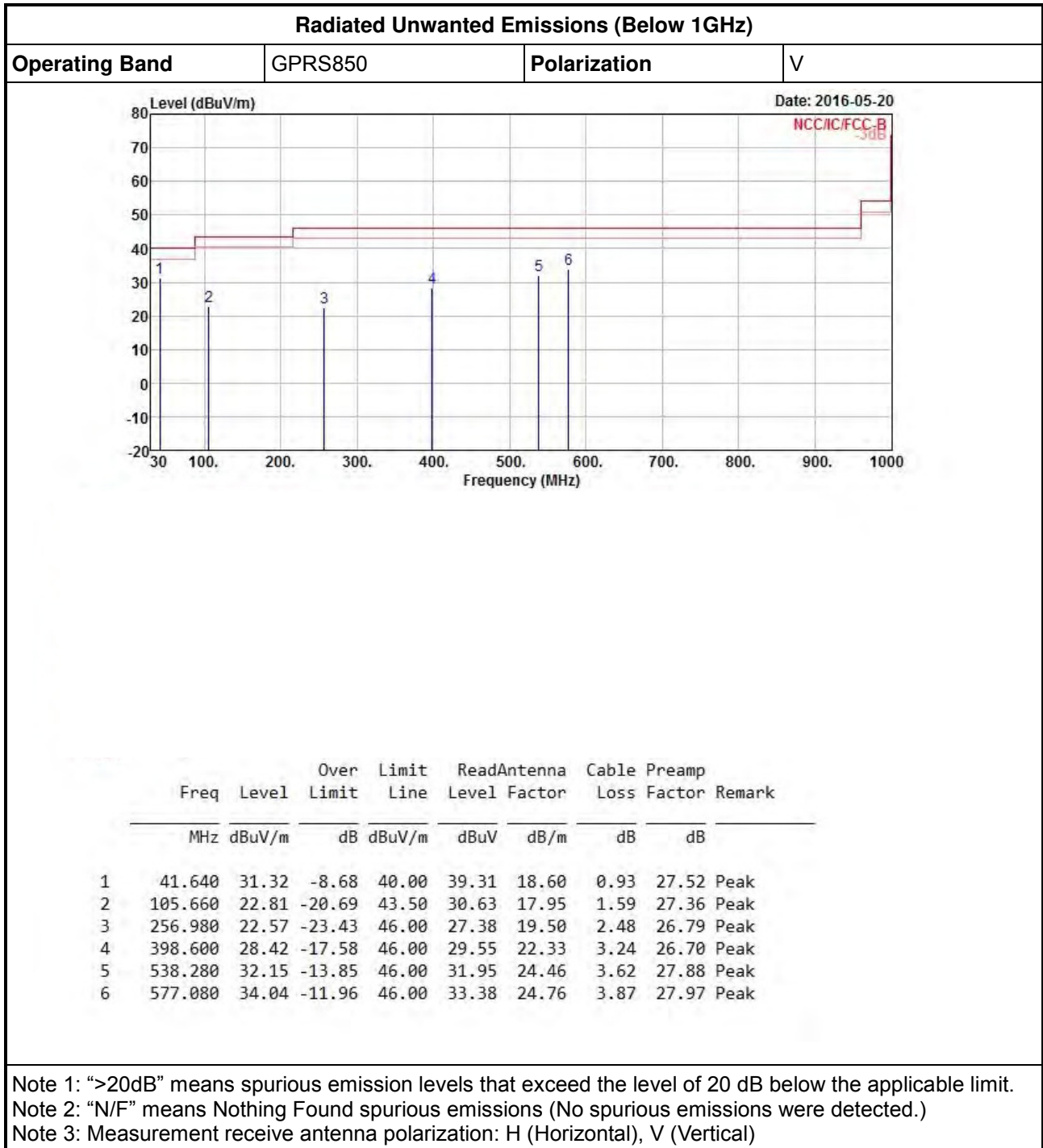



Radiated Unwanted Emissions (Below 1GHz)

Operating Band	GPRS850	Polarization	V
----------------	---------	--------------	---

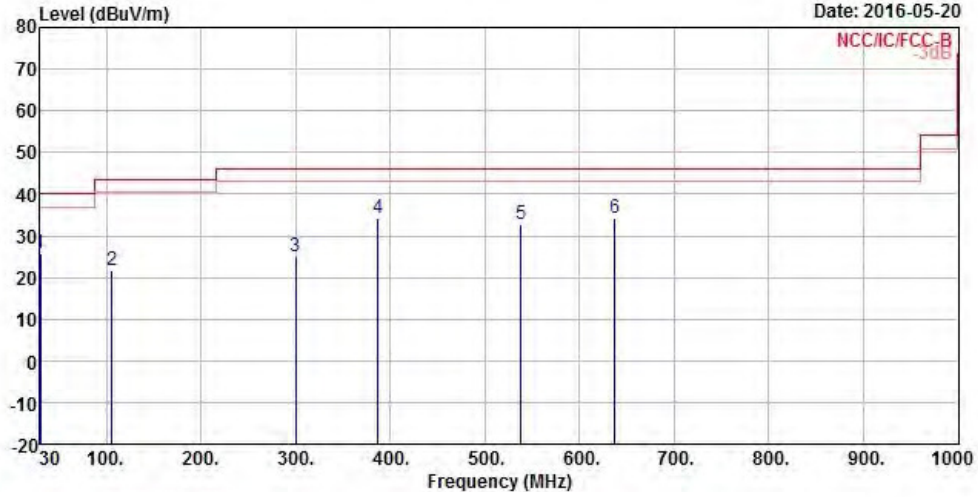

	Freq	Level	Over Limit	Limit Line	ReadAntenna Level	Antenna Factor	Cable Loss	Preamp Factor	Remark
	MHz	dBuV/m	dB	dBuV/m	dBuV	dB/m	dB	dB	
1	30.000	25.80	-14.20	40.00	25.95	26.62	0.78	27.55	Peak
2	105.660	21.67	-21.83	43.50	29.49	17.95	1.59	27.36	Peak
3	299.660	25.14	-20.86	46.00	29.46	19.77	2.61	26.70	Peak
4	386.960	34.20	-11.80	46.00	35.63	22.07	3.20	26.70	Peak
5	538.280	32.88	-13.12	46.00	32.68	24.46	3.62	27.88	Peak
6	637.220	34.26	-11.74	46.00	32.82	25.23	4.20	27.99	Peak

Note 1: ">20dB" means spurious emission levels that exceed the level of 20 dB below the applicable limit.
 Note 2: "N/F" means Nothing Found spurious emissions (No spurious emissions were detected.)
 Note 3: Measurement receive antenna polarization: H (Horizontal), V (Vertical)



Radiated Unwanted Emissions (Below 1GHz)

Operating Band	EDGE850	Polarization	V
----------------	---------	--------------	---

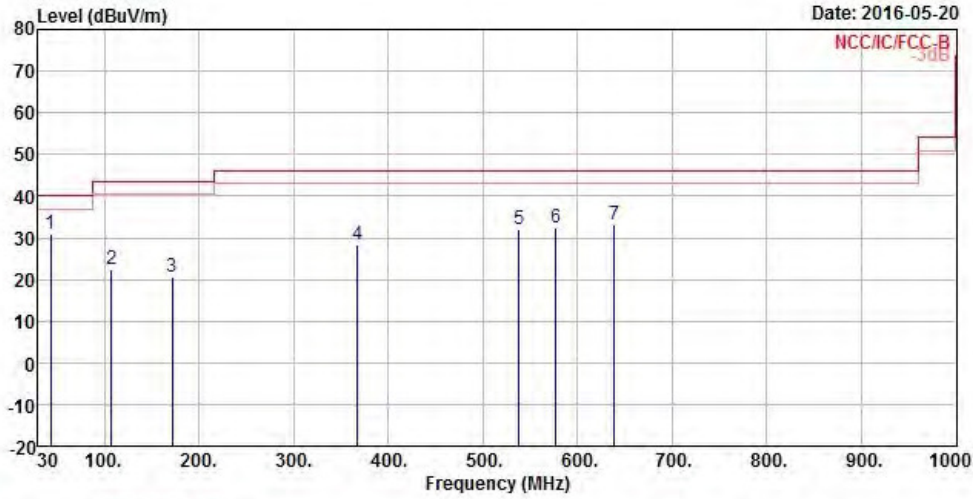

	Freq	Level	Over Limit	Limit Line	ReadAntenna Level	Antenna Factor	Cable Loss	Preamp Factor	Remark
	MHz	dBuV/m	dB	dBuV/m	dBuV	dB/m	dB	dB	
1	43.580	30.75	-9.25	40.00	39.79	17.53	0.95	27.52	Peak
2	107.600	22.40	-21.10	43.50	29.98	18.17	1.60	27.35	Peak
3	171.620	20.72	-22.78	43.50	29.81	15.89	2.07	27.05	Peak
4	367.560	28.47	-17.53	46.00	30.39	21.64	3.14	26.70	Peak
5	538.280	32.13	-13.87	46.00	31.93	24.46	3.62	27.88	Peak
6	577.080	32.43	-13.57	46.00	31.77	24.76	3.87	27.97	Peak
7	639.160	33.23	-12.77	46.00	31.74	25.26	4.21	27.98	Peak

Note 1: ">20dB" means spurious emission levels that exceed the level of 20 dB below the applicable limit.
 Note 2: "N/F" means Nothing Found spurious emissions (No spurious emissions were detected.)
 Note 3: Measurement receive antenna polarization: H (Horizontal), V (Vertical)



Radiated Unwanted Emissions (Below 1GHz)

Operating Band	EDGE850	Polarization	V
----------------	---------	--------------	---

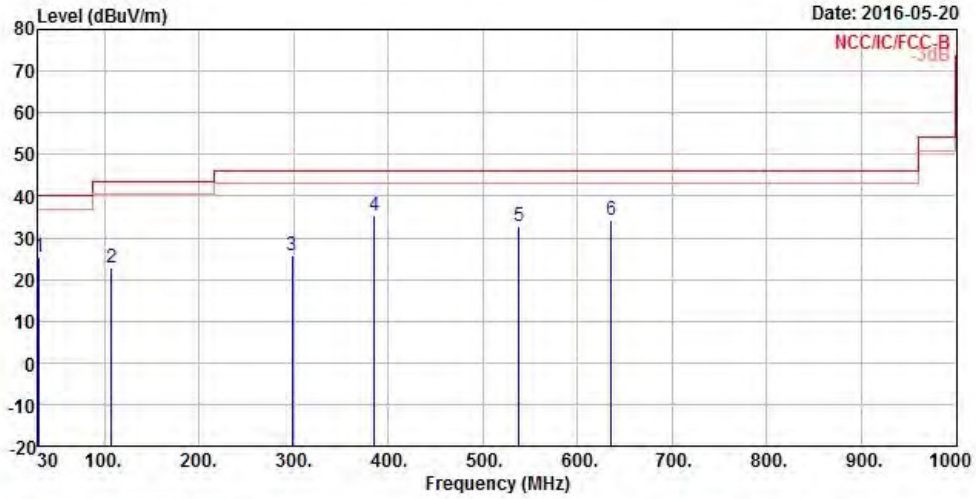

	Freq	Level	Over Limit	Limit Line	ReadAntenna Level	Antenna Factor	Cable Loss	Preamp Factor	Remark
	MHz	dBuV/m	dB	dBuV/m	dBuV	dB/m	dB	dB	
1	30.970	25.56	-14.44	40.00	26.50	25.82	0.79	27.55	Peak
2	107.600	22.82	-20.68	43.50	30.40	18.17	1.60	27.35	Peak
3	298.690	25.58	-20.42	46.00	29.92	19.75	2.61	26.70	Peak
4	385.020	35.36	-10.64	46.00	36.84	22.03	3.19	26.70	Peak
5	538.280	32.79	-13.21	46.00	32.59	24.46	3.62	27.88	Peak
6	635.280	34.29	-11.71	46.00	32.87	25.21	4.20	27.99	Peak

Note 1: ">20dB" means spurious emission levels that exceed the level of 20 dB below the applicable limit.
 Note 2: "N/F" means Nothing Found spurious emissions (No spurious emissions were detected.)
 Note 3: Measurement receive antenna polarization: H (Horizontal), V (Vertical)



Radiated Unwanted Emissions (Below 1GHz)

Operating Band	WCDMA850	Polarization	V
----------------	----------	--------------	---

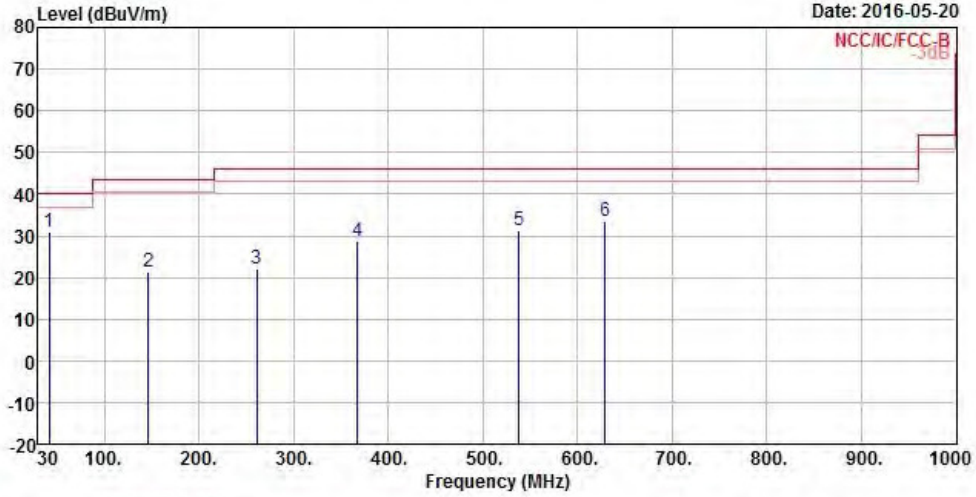

	Freq	Level	Over Limit	Limit Line	ReadAntenna Level	Antenna Factor	Cable Loss	Preamp Factor	Remark
	MHz	dBuV/m	dB	dBuV/m	dBuV	dB/m	dB	dB	
1	41.640	30.92	-9.08	40.00	38.91	18.60	0.93	27.52	Peak
2	146.400	21.46	-22.04	43.50	29.50	17.25	1.88	27.17	Peak
3	260.860	21.96	-24.04	46.00	26.53	19.73	2.49	26.79	Peak
4	367.560	28.65	-17.35	46.00	30.57	21.64	3.14	26.70	Peak
5	538.280	31.24	-14.76	46.00	31.04	24.46	3.62	27.88	Peak
6	629.460	33.65	-12.35	46.00	32.31	25.15	4.18	27.99	Peak

Note 1: ">20dB" means spurious emission levels that exceed the level of 20 dB below the applicable limit.
 Note 2: "N/F" means Nothing Found spurious emissions (No spurious emissions were detected.)
 Note 3: Measurement receive antenna polarization: H (Horizontal), V (Vertical)



Radiated Unwanted Emissions (Below 1GHz)

Operating Band	WCDMA850	Polarization	V
----------------	----------	--------------	---

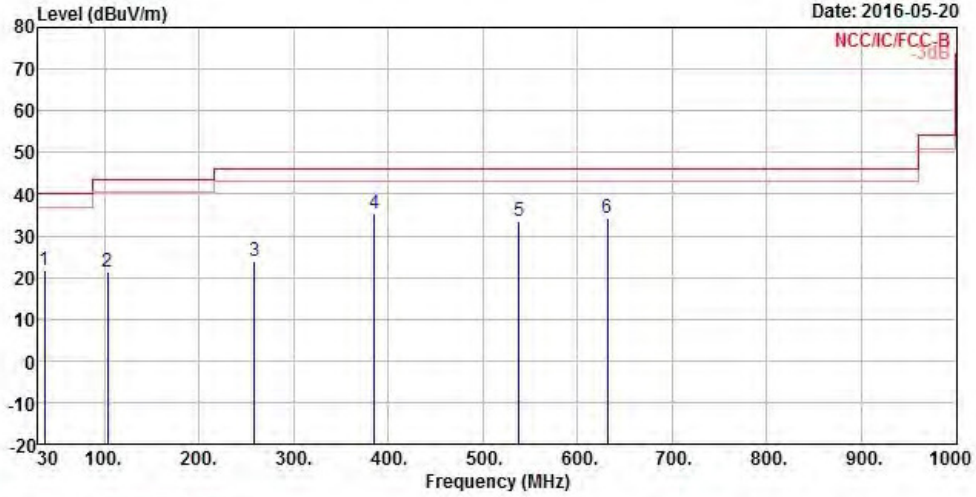

	Freq	Level	Over Limit	Limit Line	ReadAntenna Level	Cable Factor	Preamp Loss	Remark
	MHz	dBuV/m	dB	dBuV/m	dBuV	dB/m	dB	dB
1	36.790	21.75	-18.25	40.00	26.99	21.43	0.86	27.53 Peak
2	103.720	21.44	-22.06	43.50	29.49	17.74	1.58	27.37 Peak
3	258.920	23.95	-22.05	46.00	28.58	19.67	2.49	26.79 Peak
4	385.020	35.40	-10.60	46.00	36.88	22.03	3.19	26.70 Peak
5	538.280	33.43	-12.57	46.00	33.23	24.46	3.62	27.88 Peak
6	631.400	34.09	-11.91	46.00	32.73	25.17	4.18	27.99 Peak

Note 1: ">20dB" means spurious emission levels that exceed the level of 20 dB below the applicable limit.
 Note 2: "N/F" means Nothing Found spurious emissions (No spurious emissions were detected.)
 Note 3: Measurement receive antenna polarization: H (Horizontal), V (Vertical)



Radiated Unwanted Emissions (Below 1GHz)

Operating Band	GPRS1900	Polarization	V
----------------	----------	--------------	---

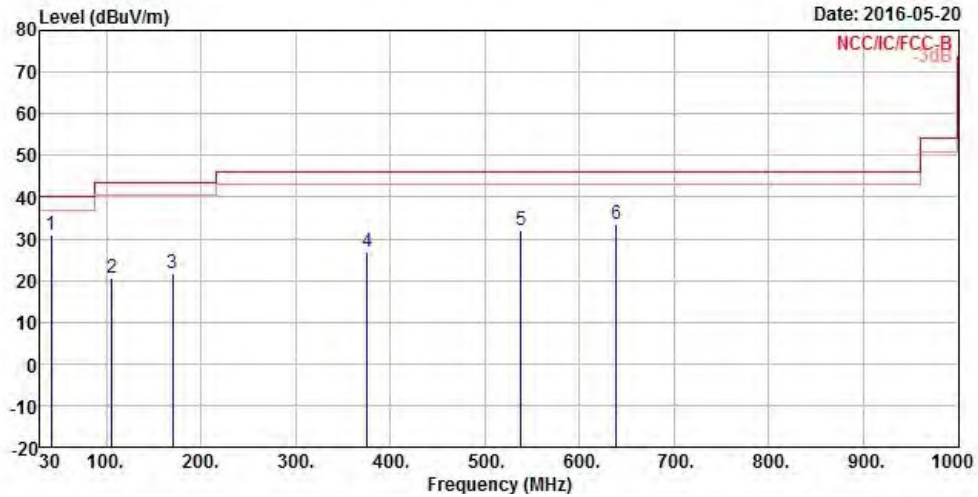

	Freq	Level	Over Limit	Limit Line	ReadAntenna Level	Antenna Factor	Cable Loss	Preamp Factor	Remark
	MHz	dBuV/m	dB	dBuV/m	dBuV	dB/m	dB	dB	
1	41.640	30.95	-9.05	40.00	38.94	18.60	0.93	27.52	Peak
2	105.660	20.60	-22.90	43.50	28.42	17.95	1.59	27.36	Peak
3	169.680	21.64	-21.86	43.50	30.67	15.97	2.06	27.06	Peak
4	375.320	26.99	-19.01	46.00	28.72	21.81	3.16	26.70	Peak
5	538.280	32.14	-13.86	46.00	31.94	24.46	3.62	27.88	Peak
6	639.160	33.49	-12.51	46.00	32.00	25.26	4.21	27.98	Peak

Note 1: ">20dB" means spurious emission levels that exceed the level of 20 dB below the applicable limit.
 Note 2: "N/F" means Nothing Found spurious emissions (No spurious emissions were detected.)
 Note 3: Measurement receive antenna polarization: H (Horizontal), V (Vertical)



Radiated Unwanted Emissions (Below 1GHz)

Operating Band	GPRS1900	Polarization	V
----------------	----------	--------------	---

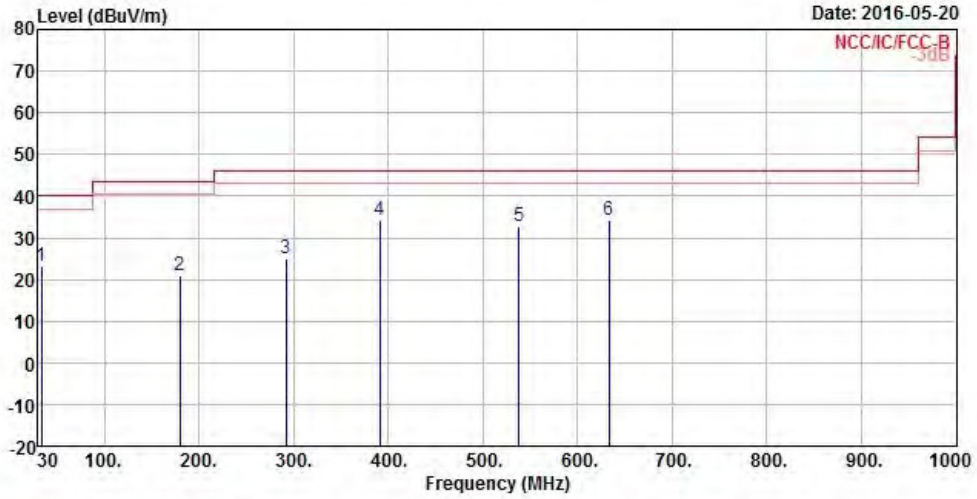

	Freq	Level	Over Limit	Limit Line	ReadAntenna Level	Antenna Factor	Cable Loss	Preamp Factor	Remark
	MHz	dBuV/m	dB	dBuV/m	dBuV	dB/m	dB	dB	
1	33.880	23.35	-16.65	40.00	26.64	23.42	0.83	27.54	Peak
2	179.380	21.02	-22.48	43.50	30.32	15.59	2.13	27.02	Peak
3	291.900	25.08	-20.92	46.00	29.62	19.59	2.59	26.72	Peak
4	390.840	34.26	-11.74	46.00	35.59	22.16	3.21	26.70	Peak
5	538.280	32.84	-13.16	46.00	32.64	24.46	3.62	27.88	Peak
6	633.340	34.06	-11.94	46.00	32.67	25.19	4.19	27.99	Peak

Note 1: ">20dB" means spurious emission levels that exceed the level of 20 dB below the applicable limit.
 Note 2: "N/F" means Nothing Found spurious emissions (No spurious emissions were detected.)
 Note 3: Measurement receive antenna polarization: H (Horizontal), V (Vertical)



Radiated Unwanted Emissions (Below 1GHz)

Operating Band	EDGE1900	Polarization	V
----------------	----------	--------------	---

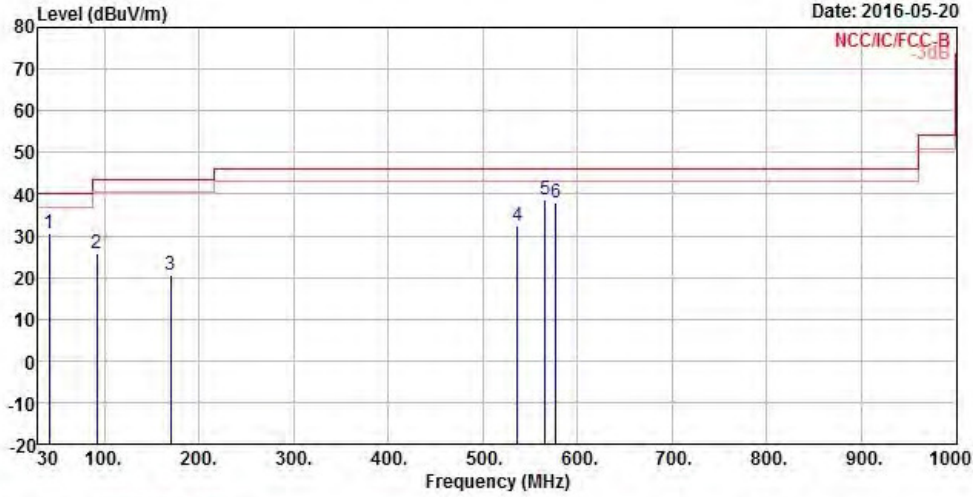

	Freq	Level	Over Limit	Limit Line	ReadAntenna Level	Antenna Factor	Cable Loss	Preamp Factor	Remark
	MHz	dBuV/m	dB	dBuV/m	dBuV	dB/m	dB	dB	
1	41.640	30.40	-9.60	40.00	38.39	18.60	0.93	27.52	Peak
2	92.080	25.83	-17.67	43.50	36.09	15.68	1.47	27.41	Peak
3	169.680	20.67	-22.83	43.50	29.70	15.97	2.06	27.06	Peak
4	536.340	32.29	-13.71	46.00	32.12	24.43	3.62	27.88	Peak
5	565.440	38.71	-7.29	46.00	38.16	24.72	3.77	27.94	Peak
6	577.080	37.85	-8.15	46.00	37.19	24.76	3.87	27.97	Peak

Note 1: ">20dB" means spurious emission levels that exceed the level of 20 dB below the applicable limit.
 Note 2: "N/F" means Nothing Found spurious emissions (No spurious emissions were detected.)
 Note 3: Measurement receive antenna polarization: H (Horizontal), V (Vertical)



Radiated Unwanted Emissions (Below 1GHz)

Operating Band	EDGE1900	Polarization	V
----------------	----------	--------------	---

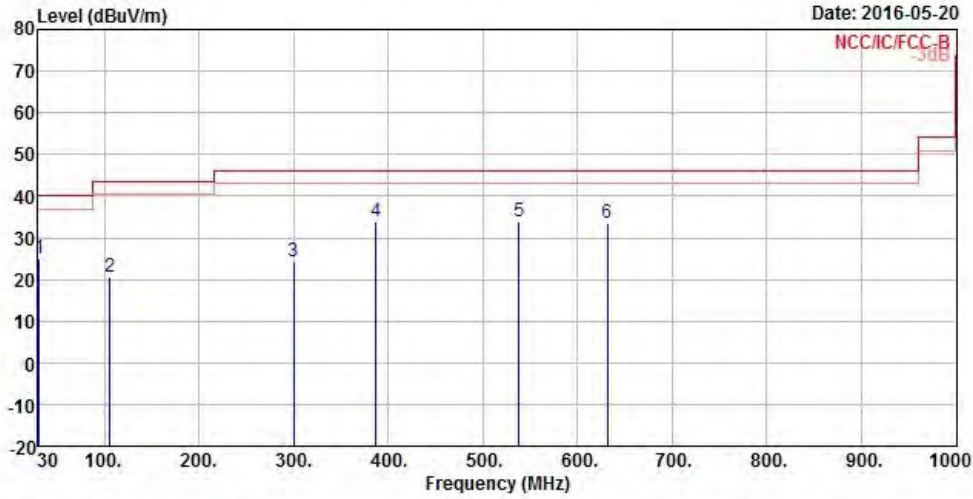

	Freq	Level	Over Limit	Limit Line	ReadAntenna Level	Antenna Factor	Cable Loss	Preamp Factor	Remark
	MHz	dBuV/m	dB	dBuV/m	dBuV	dB/m	dB	dB	
1	30.970	24.84	-15.16	40.00	25.78	25.82	0.79	27.55	Peak
2	105.660	20.50	-23.00	43.50	28.32	17.95	1.59	27.36	Peak
3	299.660	24.23	-21.77	46.00	28.55	19.77	2.61	26.70	Peak
4	386.960	33.78	-12.22	46.00	35.21	22.07	3.20	26.70	Peak
5	538.280	33.94	-12.06	46.00	33.74	24.46	3.62	27.88	Peak
6	631.400	33.56	-12.44	46.00	32.20	25.17	4.18	27.99	Peak

Note 1: ">20dB" means spurious emission levels that exceed the level of 20 dB below the applicable limit.
 Note 2: "N/F" means Nothing Found spurious emissions (No spurious emissions were detected.)
 Note 3: Measurement receive antenna polarization: H (Horizontal), V (Vertical)



Radiated Unwanted Emissions (Below 1GHz)

Operating Band	WCDMA1900	Polarization	V
----------------	-----------	--------------	---

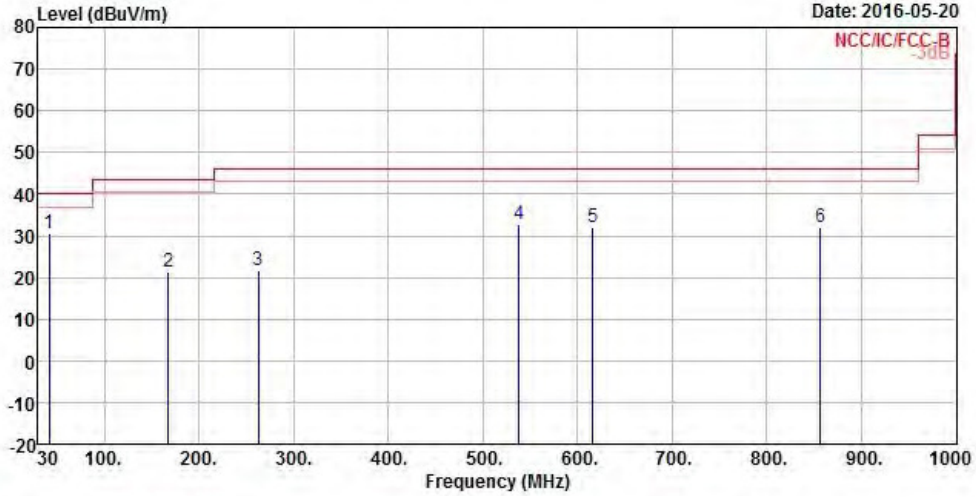

	Freq	Level	Over Limit	Limit Line	ReadAntenna Level	Antenna Factor	Cable Loss	Preamp Factor	Remark
	MHz	dBuV/m	dB	dBuV/m	dBuV	dB/m	dB	dB	
1	41.640	30.57	-9.43	40.00	38.56	18.60	0.93	27.52	Peak
2	167.740	21.43	-22.07	43.50	30.40	16.06	2.04	27.07	Peak
3	262.800	21.56	-24.44	46.00	26.19	19.65	2.50	26.78	Peak
4	538.280	32.69	-13.31	46.00	32.49	24.46	3.62	27.88	Peak
5	615.880	32.16	-13.84	46.00	31.03	25.01	4.13	28.01	Peak
6	856.440	31.95	-14.05	46.00	27.72	27.14	4.72	27.63	Peak

Note 1: ">20dB" means spurious emission levels that exceed the level of 20 dB below the applicable limit.
 Note 2: "N/F" means Nothing Found spurious emissions (No spurious emissions were detected.)
 Note 3: Measurement receive antenna polarization: H (Horizontal), V (Vertical)



Radiated Unwanted Emissions (Below 1GHz)

Operating Band	WCDMA1900	Polarization	V
----------------	-----------	--------------	---

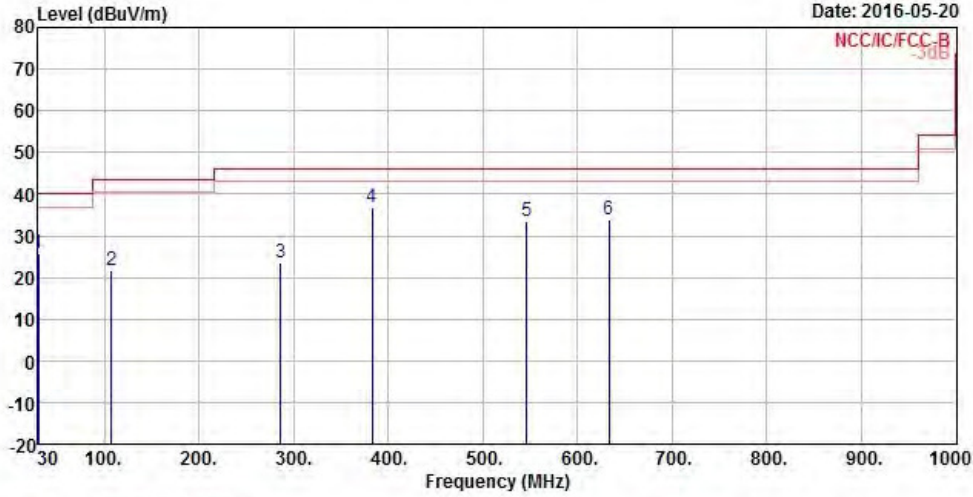

	Freq	Level	Over Limit	Limit Line	ReadAntenna Level	Antenna Factor	Cable Loss	Preamp Factor	Remark
	MHz	dBuV/m	dB	dBuV/m	dBuV	dB/m	dB	dB	
1	30.000	25.94	-14.06	40.00	26.09	26.62	0.78	27.55	Peak
2	107.600	21.58	-21.92	43.50	29.16	18.17	1.60	27.35	Peak
3	286.080	23.46	-22.54	46.00	28.12	19.50	2.57	26.73	Peak
4	383.080	36.83	-9.17	46.00	38.36	21.98	3.19	26.70	Peak
5	546.040	33.40	-12.60	46.00	33.08	24.59	3.63	27.90	Peak
6	633.340	33.92	-12.08	46.00	32.53	25.19	4.19	27.99	Peak

Note 1: ">20dB" means spurious emission levels that exceed the level of 20 dB below the applicable limit.
 Note 2: "N/F" means Nothing Found spurious emissions (No spurious emissions were detected.)
 Note 3: Measurement receive antenna polarization: H (Horizontal), V (Vertical)



3.7.6 Test Result of Transmitter Radiated Unwanted Emissions(Above 1GHz)

Mode	GPRS850								
Frequency (MHz)	ERP(dBm)	Limit(dBm)	Over Limit (dB)	SPA. Reading (dBm)	S.G. Power (dBm)	TX Cable loss (dB)	TX Antenna Gain (dBi)	Polarization (H/V)	Result
1672.80	-37.66	-13	-24.66	-33.04	-38.20	2.42	5.11	V	PASS
2509.20	-26.27	-13	-13.27	-35.75	-26.57	3.07	5.52	V	PASS
3345.60	-47.25	-13	-34.25	-49.50	-49.32	3.48	7.70	H	PASS

Mode	EDGE850								
Frequency (MHz)	ERP(dBm)	Limit(dBm)	Over Limit (dB)	SPA. Reading (dBm)	S.G. Power (dBm)	TX Cable loss (dB)	TX Antenna Gain (dBi)	Polarization (H/V)	Result
1672.80	-41.88	-13	-28.88	-41.13	-42.42	2.42	5.11	V	PASS
2509.20	-48.35	-13	-35.35	-41.14	-48.65	3.07	5.52	V	PASS
3345.60	-52.13	-13	-39.13	-53.82	-54.20	3.48	7.70	H	PASS

Mode	WCDMA850								
Frequency (MHz)	ERP(dBm)	Limit(dBm)	Over Limit (dB)	SPA. Reading (dBm)	S.G. Power (dBm)	TX Cable loss (dB)	TX Antenna Gain (dBi)	Polarization (H/V)	Result
1672.80	-64.58	-13	-51.58	-48.57	-65.12	2.42	5.11	V	PASS
2509.20	-61.00	-13	-48.00	-57.29	-61.30	3.07	5.52	V	PASS
3345.60	-65.43	-13	-52.43	-63.13	-67.50	3.48	7.70	H	PASS



Mode	GPRS1900								
Frequency (MHz)	EIRP(dBm)	Limit(dBm)	Over Limit (dB)	SPA. Reading (dBm)	S.G. Power (dBm)	TX Cable loss (dB)	TX Antenna Gain (dBi)	Polarization (H/V)	Result
3760	-45.03	-13	-32.03	-40.46	-49.67	3.77	8.41	H	PASS
5640	-43.68	-13	-30.68	-44.06	-48.93	5.01	10.26	H	PASS
7520	-41.70	-13	-28.70	-62.08	-47.82	5.70	11.82	H	PASS

Mode	EDGE1900								
Frequency (MHz)	EIRP(dBm)	Limit(dBm)	Over Limit (dB)	SPA. Reading (dBm)	S.G. Power (dBm)	TX Cable loss (dB)	TX Antenna Gain (dBi)	Polarization (H/V)	Result
3760	-47.32	-13	-34.32	-41.01	-51.96	3.77	8.41	H	PASS
5640	-44.71	-13	-31.71	-40.91	-49.96	5.01	10.26	V	PASS
7520	-41.97	-13	-28.97	-62.45	-48.09	5.70	11.82	H	PASS

Mode	WCDMA1900								
Frequency (MHz)	EIRP(dBm)	Limit(dBm)	Over Limit (dB)	SPA. Reading (dBm)	S.G. Power (dBm)	TX Cable loss (dB)	TX Antenna Gain (dBi)	Polarization (H/V)	Result
3760	-43.77	-13	-30.77	-52.13	-48.41	3.77	8.41	H	PASS
5640	-54.14	-13	-41.14	-54.23	-59.39	5.01	10.26	H	PASS
7520	-49.64	-13	-36.64	-62.33	-55.76	5.70	11.82	H	PASS

3.8 Frequency Stability

3.8.1 Frequency Stability Limit

Frequency Stability Limit	
<input checked="" type="checkbox"/>	The transmitter center frequency stability shall be ± 2.5 ppm maximum. The frequency stability shall be sufficient to ensure that the fundamental emissions stay within the authorized bands of operation.
<input checked="" type="checkbox"/>	Temperature:
<input checked="" type="checkbox"/>	-30°C to +50°C in 10°C step.
<input checked="" type="checkbox"/>	If the EUT cannot be turned on at -30°C, the testing lowest temperature will be raised in 10°C step until the EUT can be turned on.
<input checked="" type="checkbox"/>	Voltage:
<input checked="" type="checkbox"/>	For non hand-carried battery and AC powered equipment: 85% to 115% of the nominal value
<input checked="" type="checkbox"/>	For hand-carried, battery-powered equipment: Voltage is reduced to the battery operating end point which shall be specified by the manufacturer.
Note 1: These measurements shall also be performed at normal and extreme test conditions.	

3.8.2 Measuring Instruments

Refer a test equipment and calibration data table in this test report.

3.8.3 Test Procedures

Test Method	
<input checked="" type="checkbox"/>	Refer as ANSI/TIA-603-D-2010, clause 3.2.2 for frequency stability tests
<input checked="" type="checkbox"/>	Frequency stability with respect to ambient temperature
<input checked="" type="checkbox"/>	Frequency stability when varying supply voltage
<input checked="" type="checkbox"/>	For conducted measurement.
<input checked="" type="checkbox"/>	For conducted measurements on devices with multiple transmit chains: Measurements need only to be performed on one of the active transmit chains (antenna outputs)
<input type="checkbox"/>	For radiated measurement. The equipment to be measured and the test antenna shall be oriented to obtain the maximum emitted power level.

3.8.4 Test Setup

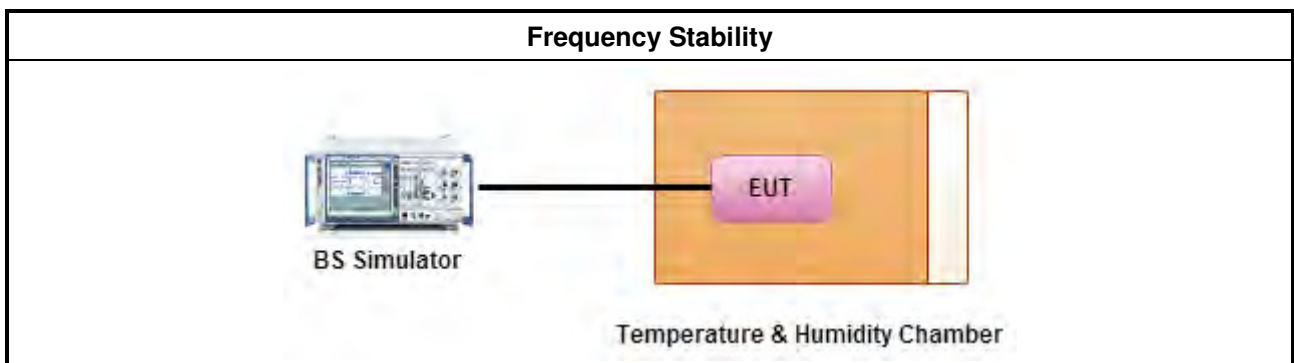



3.8.5 Test Result of Frequency Stability

Mode		GPRS850		EDGE850		WCDMA850	
Channel		189		189		4182	
Frequency (MHz)		836.4		836.4		836.4	
Temp. (°C)	Voltage (V)	Frequency Error (Hz)	Frequency Error (ppm)	Frequency Error (Hz)	Frequency Error (ppm)	Frequency Error (Hz)	Frequency Error (ppm)
50	7.4	17.45	0.0209	-20.97	-0.0251	-5.57	-0.0067
40	7.4	15.43	0.0184	-17.31	-0.0207	-6.19	-0.0074
30	7.4	13.99	0.0167	-20.72	-0.0248	-4.96	-0.0059
20	7.4	14.41	0.0172	-15.95	-0.0191	-6.67	-0.0080
10	7.4	14.6	0.0175	-16.95	-0.0203	-4.94	-0.0059
0	7.4	14.15	0.0169	-18.70	-0.0224	-5.49	-0.0066
-10	7.4	14.35	0.0172	-17.85	-0.0213	-4.69	-0.0056
-20	7.4	14.28	0.0171	-19.91	-0.0238	-4.80	-0.0057
-30	7.4	13.56	0.0162	-18.81	-0.0225	-4.91	-0.0059
20	8.4	13.28	0.0159	-20.84	-0.0249	-6.48	-0.0077
20	7.4	14.41	0.0172	-15.95	-0.0191	-6.67	-0.0080
20	6.0	15.16	0.0181	-16.06	-0.0192	-4.40	-0.0053
Limit [ppm]		± 2.5					



Mode		GPRS1900		EDGE1900		WCDMA1900	
Channel		661		661		9400	
Frequency (MHz)		1880		1880		1880	
Temp. (°C)	Voltage (V)	Frequency Error (Hz)	Frequency Error (ppm)	Frequency Error (Hz)	Frequency Error (ppm)	Frequency Error (Hz)	Frequency Error (ppm)
50	7.4	21.83	0.0116	-20.57	-0.0109	-12.78	-0.0068
40	7.4	16.43	0.0087	-24.46	-0.0130	-16.04	-0.0085
30	7.4	16.08	0.0086	-22.28	-0.0119	-12.96	-0.0069
20	7.4	18.48	0.0098	-21.56	-0.0115	-13.87	-0.0074
10	7.4	17.99	0.0096	-24.06	-0.0128	-12.02	-0.0064
0	7.4	16.74	0.0089	-22.72	-0.0121	-10.48	-0.0056
-10	7.4	16.55	0.0088	-25.63	-0.0136	-13.25	-0.0070
-20	7.4	20.45	0.0109	-24.52	-0.0130	-14.23	-0.0076
-30	7.4	17.35	0.0092	-22.44	-0.0119	-11.41	-0.0061
20	8.4	15.88	0.0084	-17.81	-0.0095	-14.50	-0.0077
20	7.4	18.48	0.0098	-21.56	-0.0115	-13.87	-0.0074
20	6.0	17.26	0.0092	-26.06	-0.0139	-14.57	-0.0078
Limit [ppm]		± 2.5					



4 Test Equipment and Calibration Data

Instrument for Conducted Test

Instrument	Manufacturer	Model No.	Serial No.	Characteristics	Calibration Date	Next Calibration Date
Spectrum Analyzer	R&S	FSV 40	101500	9KHz~40GHz	May 12, 2016	May 11, 2017
Wireless communication test Set	Agilent	8960	MY53202225	Wireless communication	Jul. 6, 2015	Jul. 5, 2016
Temp. and Humidity Chamber	Giant Force	GTH-225-20-SP-SD	MAA1112-007	-20 ~ 100°C	Apr. 25, 2016	Apr. 24, 2017
DC Power Source	G.W.	GPC-6030D	C671845	DC 1V ~ 60V	Jul. 22, 2015	Jul. 21, 2016

Instrument for Radiated Test

Instrument	Manufacturer	Model No.	Serial No.	Characteristics	Calibration Date	Next Calibration Date
3m Semi Anechoic Chamber	SIDT FRANKONIA	SAC-3M	03CH03-HY	30MHz ~ 1GHz 3m	Nov. 28, 2015	Nov. 27, 2016
3m Semi Anechoic Chamber	SIDT FRANKONIA	SAC-3M	03CH03-HY	1GHz ~ 18GHz 3m	Dec. 16, 2015	Dec. 15, 2016
Amplifier	HP	8447D	2944A08033	10kHz ~ 1.3GHz	MaY 10, 2016	May 09, 2017
Wireless communication test Set	Agilent	8960	MY53202225	Wireless communication	Jul. 6, 2015	Jul. 5, 2016
Amplifier	Agilent	8449B	3008A02120	1GHz ~ 26.5GHz	Sep. 02, 2015	Sep. 01, 2016
Spectrum	R&S	FSV40	101513	9kHz ~ 40GHz	Feb. 16, 2016	Feb. 15, 2017
Bilog Antenna	SCHAFFNER	CBL 6112D	22237	30MHz ~ 1GHz	Sep. 18, 2015	Sep. 17, 2016
Horn Antenna	SCHWARZBECK	BBHA9120D	1531	1GHz ~ 18GHz	Apr. 22, 2016	Apr. 21, 2017
Horn Antenna	SCHWARZBECK	BBHA9170	BBHA9170154	18GHz ~ 40GHz	Jan. 29, 2016	Jan. 28, 2017