



# FCC Part 15.247

## TEST REPORT

For

### AAEON Technology Inc.

5F, No. 135, Lane 235, Pao Chiao Rd., Hsin-Tien Dist., New Taipei City 23145, Taiwan, R.O.C

**FCC ID: OHBBOXERRK99WB**

<b>Report Type</b> Original Report	<b>Product Type:</b> Embedded Controller
<b>Report Producer :</b>	Himiko Chen <i>Himiko Chen</i>
<b>Report Number :</b>	RLK1808007-00B
<b>Report Date :</b>	2018/10/19
<b>Reviewed By:</b>	Jerry Chang <i>Jerry Chang</i>
<b>Prepared By:</b> Bay Area Compliance Laboratories Corp.(Taiwan) 70, Lane 169, Sec. 2, Datong Road, Xizhi Dist., New Taipei City 22183, Taiwan, R.O.C. Tel: +886 (2)2647 6898 Fax: +886 (2) 2647 6895 <a href="http://www.bacl.com.tw">www.bacl.com.tw</a>	

**Note:** This test report is prepared for the customer shown above and for the device described herein. It may not be duplicated or used in part without prior written consent from Bay Area Compliance Laboratories Corp. (Taiwan)

## Revision History

Revision	Report Number	Issue Date	Description	Author/Revised by
1.0	RLK1808007-00C	2018/10/19	Original Report	Himiko Chen

## TABLE OF CONTENTS

<b>1</b>	<b>GENERAL INFORMATION .....</b>	<b>5</b>
1.1	PRODUCT DESCRIPTION FOR EQUIPMENT UNDER TEST (EUT) .....	5
1.2	OPERATION CONDITION OF EUT.....	6
1.3	OBJECTIVE AND TEST METHODOLOGY .....	6
1.4	MEASUREMENT UNCERTAINTY.....	6
1.5	TEST FACILITY.....	6
<b>2</b>	<b>SYSTEM TEST CONFIGURATION.....</b>	<b>7</b>
2.1	DESCRIPTION OF TEST CONFIGURATION .....	7
2.2	DESCRIPTION OF WORST TEST CONFIGURATION.....	7
2.3	SUPPORT EQUIPMENT LIST AND DETAILS.....	8
2.4	EXTERNAL CABLE LIST AND DETAILS .....	8
2.5	BLOCK DIAGRAM OF TEST SETUP.....	8
<b>3</b>	<b>SUMMARY OF TEST RESULTS.....</b>	<b>10</b>
<b>4</b>	<b>FCC §15.247(I), § 1.1310, § 2.1091 – MAXIMUM PERMISSIBLE EXPOSURE (MPE).....</b>	<b>11</b>
4.1	APPLICABLE STANDARD .....	11
4.2	RF EXPOSURE EVALUATION RESULT .....	12
<b>5</b>	<b>FCC §15.203 – ANTENNA REQUIREMENTS .....</b>	<b>13</b>
5.1	APPLICABLE STANDARD .....	13
5.2	ANTENNA LIST AND DETAILS.....	13
<b>6</b>	<b>FCC §15.207 - AC LINE CONDUCTED EMISSIONS .....</b>	<b>14</b>
6.1	APPLICABLE STANDARD .....	14
6.2	EUT SETUP .....	14
6.3	EMI TEST RECEIVER SETUP .....	15
6.4	TEST PROCEDURE .....	15
6.5	TEST EQUIPMENT LIST AND DETAILS.....	15
6.6	TEST ENVIRONMENTAL CONDITIONS .....	15
6.7	AC LINE CONDUCTED EMISSION TEST PLOT AND DATA .....	16
<b>7</b>	<b>FCC §15.209, §15.205, §15.247(D) – SPURIOUS EMISSIONS.....</b>	<b>18</b>
7.1	APPLICABLE STANDARD .....	18
7.2	EUT SETUP .....	19
7.3	EMI TEST RECEIVER & SPECTRUM ANALYZER SETUP .....	19
7.4	TEST PROCEDURE .....	20
7.5	TEST EQUIPMENT LIST AND DETAILS.....	20
7.6	TEST ENVIRONMENTAL CONDITIONS .....	20
7.7	RADIATED EMISSION TEST PLOT AND DATA.....	21
<b>8</b>	<b>FCC §15.247(A)(1) – 20 DB EMISSION BANDWIDTH .....</b>	<b>32</b>
8.1	APPLICABLE STANDARD .....	32
8.2	TEST PROCEDURE .....	32
8.3	TEST EQUIPMENT LIST AND DETAILS.....	32
8.4	TEST ENVIRONMENTAL CONDITIONS .....	32
8.5	TEST RESULTS .....	33
<b>9</b>	<b>FCC §15.247(A)(1) – CHANNEL SEPARATION TEST .....</b>	<b>37</b>
9.1	APPLICABLE STANDARD .....	37
9.2	TEST PROCEDURE .....	37
9.3	TEST EQUIPMENT LIST AND DETAILS.....	37
9.4	TEST ENVIRONMENTAL CONDITIONS .....	37
9.5	TEST RESULTS .....	38
<b>10</b>	<b>FCC §15.247(A)(1)(III) – TIME OF OCCUPANCY (DWELL TIME).....</b>	<b>42</b>

10.1 APPLICABLE STANDARD .....42

10.2 TEST PROCEDURE .....42

10.3 TEST EQUIPMENT LIST AND DETAILS.....42

10.4 TEST ENVIRONMENTAL CONDITIONS .....42

10.5 TEST RESULTS .....43

**11 FCC §15.247(A)(1)(III) –QUANTITY OF HOPPING CHANNEL TEST .....45**

11.1 APPLICABLE STANDARD .....45

11.2 TEST PROCEDURE .....45

11.3 TEST EQUIPMENT LIST AND DETAILS.....45

11.4 TEST ENVIRONMENTAL CONDITIONS .....45

11.5 TEST RESULTS .....45

**12 FCC §15.247(B)(1) – MAXIMUM OUTPUT POWER .....47**

12.1 APPLICABLE STANDARD .....47

12.2 TEST PROCEDURE .....47

12.3 TEST EQUIPMENT LIST AND DETAILS.....47

12.4 TEST ENVIRONMENTAL CONDITIONS .....47

12.5 TEST RESULTS .....48

**13 FCC §15.247(D) – 100 KHZ BANDWIDTH OF FREQUENCY BAND EDGE.....49**

13.1 APPLICABLE STANDARD .....49

13.2 TEST PROCEDURE .....49

13.3 TEST EQUIPMENT LIST AND DETAILS.....49

13.4 TEST ENVIRONMENTAL CONDITIONS .....49

13.5 TEST RESULTS .....50

## 1 General Information

### 1.1 Product Description for Equipment under Test (EUT)

<b>Applicant</b>	<b>AAEON Technology Inc.</b> 5F, No. 135, Lane 235, Pao Chiao Rd., Hsin-Tien Dist., New Taipei City 23145, Taiwan, R.O.C
<b>Manufacturer</b>	<b>AAEON Technology Inc.</b> 5F, No. 135, Lane 235, Pao Chiao Rd., Hsin-Tien Dist., New Taipei City 23145, Taiwan, R.O.C
<b>Brand(Trade) Name</b>	AAEON
<b>Product (Equipment)</b>	Embedded Controller
<b>Model Name</b>	BOXER-RK99
<b>Series Model</b>	xBOXER-RK99x (x - Where x may be any combination of alphanumeric characters or "-" or blank.)
<b>Model Discrepancy</b>	For marketing purpose
<b>EUT Function</b>	BT: BR+EDR
<b>Frequency Range</b>	2402 MHz ~ 2480 MHz
<b>Number of Channels</b>	79 Channels
<b>Output Power</b>	BT BR(GFSK) Mode: -4.41 dBm (0.00036W) BT EDR( $\pi/4$ -DQPSK) Mode: -8.42 dBm(0.00014W) BT EDR(8-DPSK) Mode: -8.21 dBm (0.000151W)
<b>Received Date</b>	Aug. 19, 2018.
<b>Date of Test</b>	Aug. 19, 2018 ~ Oct. 16, 2018
<b>Related Submittal(s)/Grant(s)</b>	FCC Part 15.247 DTS with FCC ID : OHBBOXERRK99WB
<b>Modulation Type</b>	BT BR Mode: GFSK BT EDR-2M Mode: $\pi/4$ -DQPSK BT EDR-3M Mode: 8-DPSK

*\*All measurement and test data in this report was gathered from production sample serial number: 1808007 (Assigned by BACL, Taiwan).*

*\*Model Discrepancy,*

*The major electrical and mechanical constructions of series models are identical to the basic model, except different Market segmentation. The model, BOXER-RK99 is the testing sample, and the final test data are shown on this test report.*

### 1.2 Operation Condition of EUT

<b>Power Operation (Voltage Range)</b>	<input checked="" type="checkbox"/> AC 120V/60Hz <input checked="" type="checkbox"/> Adapter <i>Brand Name: FSP</i> <i>Model: FSP060-DIBAN2</i> <i>I/P: 100-240Vac, 1.5A</i> <i>O/P: 12Vdc, 5A</i> <input type="checkbox"/> By Power Core
	<input type="checkbox"/> DC Type <input type="checkbox"/> DC Power Supply <input type="checkbox"/> Battery : <input type="checkbox"/> External from USB Cable <input type="checkbox"/> External DC Adapter
	<input type="checkbox"/> Host System

\*The worst was Adapter mode

### 1.3 Objective and Test Methodology

The Objective and Test Methodology of this Test Report was to document the compliance of the InnoComm Mobile Technology Corporation Appliance (Model: BOXER-RK99; xBOXER-RK99x (x - Where x may be any combination of alphanumeric characters or "-" or blank.)) to the requirements of the following Standards:

-Part 2, Subpart J, Part 15, Subparts A and C, section 15.247 of the Federal Communication Commission's rules.

-ANSI C63.10-2013 of the American National Standard of Procedures for Compliance Testing of Unlicensed Wireless Devices.

### 1.4 Measurement Uncertainty

Parameter	Expanded Measurement uncertainty
RF output power with Power Meter	± 0.55 dB
Occupied Channel Bandwidth	± 4.45 %
RF Conducted test with Spectrum	± 1.45 dB
AC Power Line Conducted Emission	± 4.64 dB
Radiated Below 1G	± 5.83 dB
Radiated Above 1G-18G	± 5.35 dB
Radiated Above 18G-40G	± 4.49 dB

### 1.5 Test Facility

The Test site used by Bay Area Compliance Laboratories Corp. (Taiwan) to collect test data is located on

70, Lane 169, Sec. 2, Datong Road, Xizhi Dist., New Taipei City 22183, Taiwan, R.O.C.

68-3, Lane 169, Sec. 2, Datong Road, Xizhi Dist., New Taipei City 22183, Taiwan, R.O.C.

## 2 System Test Configuration

### 2.1 Description of Test Configuration

The system was configured for testing in testing mode which was provided by manufacturer.

No special accessory, No modification was made to the EUT and No special equipment used during test.

For BR/EDR mode, there are totally 79 channels.

Channel	Frequency (MHz)	Channel	Frequency (MHz)
0	2402	39	2441
1	2403	-	-
2	2404	-	-
3	2405	-	-
4	2406	76	2478
-	-	77	2479
38	2440	78	2480

For BT BR/EDR modes: Channel 0, 39 and 78 were tested.

Radiated below 1G were tested worst output power mode.

### 2.2 Description of Worst Test Configuration

Modulation Used for Conformance Test	
Configuration	Data Rate
BR (GFSK) mode	1 Mbps
EDR ( $\pi/4$ -DQPSK) mode	2 Mbps
EDR (8DPSK) mode	3 Mbps

Worst Case of Power Setting			
EUT Exercise Software	RFTestTool		
	Low CH	Mid CH	High CH
BR (GFSK) mode	Default	Default	Default
EDR ( $\pi/4$ -DQPSK) mode	Default	Default	Default
EDR (8DPSK) mode	Default	Default	Default

### 2.3 Support Equipment List and Details

No.	Description	Manufacturer	Model Number	BSMI	FCC ID/ DoC
1	Monitor	DELL	P2415Q	N/A	DoC
2	Adapter	FSP	FSP060-DIBAN2	R43001	DoC
3	Modem	NA	TY5600	NA	DoC
4	HDD	WD	WDBUZG0010BBK-WESN	NA	DoC
5	Mouse	ASUS	MOBTU0A	NA	DoC
6	Keyboard	ASUS	AW211	NA	DoC
7	Notebook	DELL	Latitude E5470	R33002	DoC

### 2.4 External Cable List and Details

No.	Cable Description	Length (m)	From	To
1	HDIM CABLE	1.8	EUT	Monitor
2	DC CABLE	1.8	EUT	Adapter
3	RS232 CABLE	1.8	EUT	Modem
4	TYPE C TO USB 3.0 CABLE	0.1	EUT	HDD
5	USB 3.0 HDD CABLE	0.5	EUT	HDD
6	MOUSE USB CABLE	1.8	EUT	Mouse
7	KEYBOARD USB CABLE	1.8	EUT	Keyboard
8	LAN CABLE	10.0	EUT	Notebook PC

### 2.5 Block Diagram of Test Setup

#### Conduction

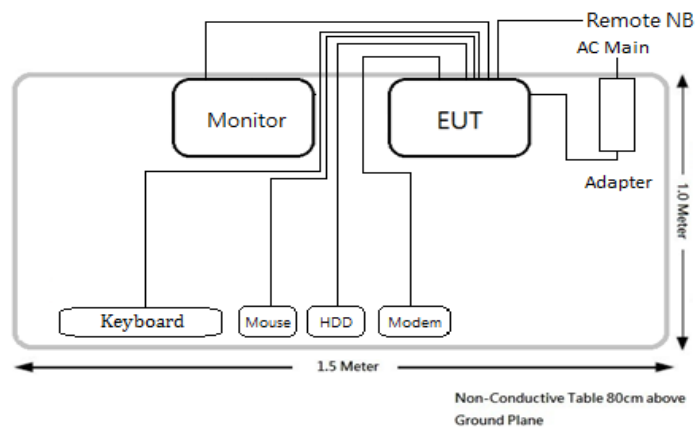



**Radiation below 1G**

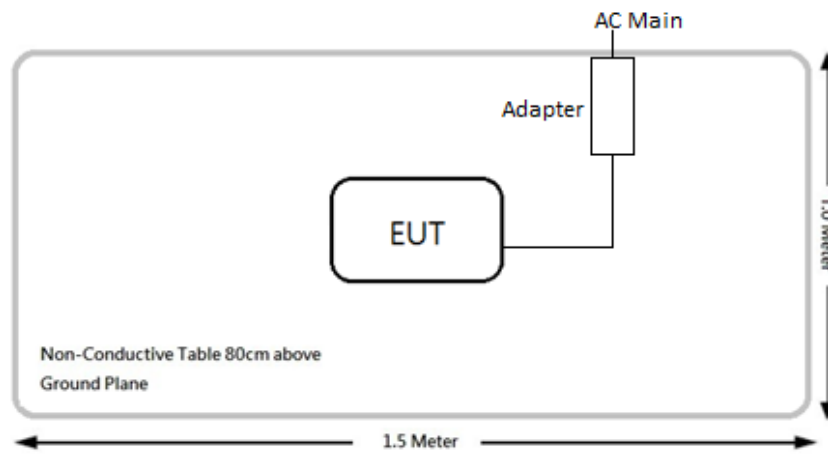

**Radiation above 1G**

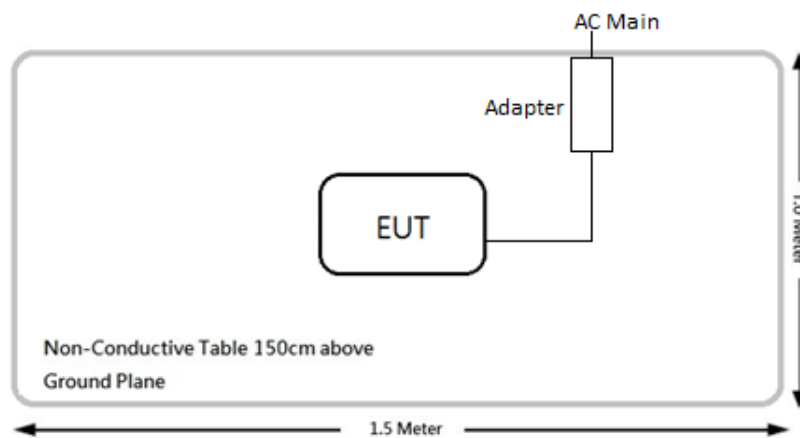

### 3 Summary of Test Results

FCC Rules	Description of Test	Result
§ 15.247(i), § 1.1310, § 2.1091	Maximum Permissible Exposure (MPE)	Compliance
§15.203	Antenna Requirement	Compliance
§15.207(a)	AC Line Conducted Emissions	Compliance
§15.205, §15.209, §15.247(d)	Spurious Emissions	Compliance
§15.247(a)(1)	20 dB Emission Bandwidth	Compliance
§15.247 (a)(1)	Channel Separation Test	Compliance
§15.247(a)(1)(iii)	Time of Occupancy (Dwell Time)	Compliance
§15.247(a)(1)(iii)	Quantity of hopping channel Test	Compliance
§15.247(b)(3)	Maximum Peak Output Power	Compliance
§15.247(d)	100 kHz Bandwidth of Frequency Band Edge	Compliance

## 4 FCC §15.247(i), § 1.1310, § 2.1091 – Maximum Permissible Exposure (MPE)

### 4.1 Applicable Standard

According to subpart 15.247(i) and subpart §1.1310, systems operating under the provisions of this section shall be operated in a manner that ensures that the public is not exposed to radio frequency energy level in excess of the Commission’s guidelines.

Limits for Maximum Permissible Exposure (MPE) (§1.1310, §2.1091)

<b>(B) Limits for General Population/Uncontrolled Exposure</b>				
Frequency Range (MHz)	Electric Field Strength (V/m)	Magnetic Field Strength (A/m)	Power Density (mW/cm <sup>2</sup> )	Averaging Time (minutes)
0.3–1.34	614	1.63	*(100)	30
1.34–30	824/f	2.19/f	*(180/f <sup>2</sup> )	30
30–300	27.5	0.073	0.2	30
300–1500	/	/	f/1500	30
1500–100,000	/	/	1.0	30

*f = frequency in MHz; \* = Plane-wave equivalent power density;*

According to §1.1310 and §2.1091 RF exposure is calculated.

**Calculated Formulary:** Predication of MPE limit at a given distance

$S = PG/4\pi R^2$  = power density (in appropriate units, e.g. mW/cm<sup>2</sup>);

P = power input to the antenna (in appropriate units, e.g., mW);

G = power gain of the antenna in the direction of interest relative to an isotropic radiator, the power gain factor, is normally numeric gain;

R = distance to the center of radiation of the antenna (appropriate units, e.g., cm);

**For simultaneously transmit system, the calculated power density should comply with:**

$$\sum_i \frac{S_i}{S_{Limit,i}} \leq 1$$

## 4.2 RF Exposure Evaluation Result

### MPE evaluation:

Mode	Frequency Range (MHz)	Antenna Gain		Target Power		Evaluation Distance (cm)	Power Density (mW/cm <sup>2</sup> )	MPE Limit (mW/cm <sup>2</sup> )
		(dBi)	(numeric)	(dBm)	(mW)			
Wi-Fi 2.4G	2412-2462	2.50	1.778	23.00	199.526	20	0.0706	1
BLE	2402-2480	2.50	1.778	3.00	1.995	20	0.0007	1
BR+EDR	2402-2480	2.50	1.778	-4.00	0.398	20	0.0001	1

The Wi-Fi and BT can transmit simultaneously:

$$=S_{\text{Wi-Fi}}/S_{\text{limit-Wi-Fi}} + S_{\text{BLE}}/S_{\text{limit-BLE}} = 0.0706 + 0.0007 = 0.0713 < 1.0$$

**Result:** MPE evaluation meet 20 cm the requirement of standard.

## 5 FCC §15.203 – Antenna Requirements

### 5.1 Applicable Standard

According to § 15.203,

An intentional radiator shall be designed to ensure that no antenna other than that furnished by the responsible party shall be used with the device. The use of a permanently attached antenna or of an antenna that uses a unique coupling to the intentional radiator shall be considered sufficient to comply with the provisions of this section. The manufacturer may design the unit so that a broken antenna can be replaced by the user, but the user of a standard antenna jack or electrical connector is prohibited.

And according to FCC 47 CFR section 15.247 (b), if the transmitting antennas of directional gain greater than 6dBi are used, the power shall be reduced by the amount in dB that the directional gain of the antenna does not exceed 6 dBi

### 5.2 Antenna List and Details

Manufacturer	Model	Antenna Type	Antenna Gain	Result
Aristotle	RFA-02-C2M2-M32-3	Dipole Antenna	2.50 dBi	Compliance

*The EUT has an external dedicated antennas arrangement and the connector type is RP-SMA Male, fulfill the requirement of this section.*

## 6 FCC §15.207 - AC Line Conducted Emissions

### 6.1 Applicable Standard

According to FCC §15.207

For an intentional radiator that is designed to be connected to the public utility (AC) power line, the radio frequency voltage that is conducted back onto the AC power line on any frequency or frequencies within the band 150 kHz to 30 MHz shall not exceed the limits in the following table, as measured using a 50  $\mu$ H/50 ohms line impedance stabilization network (LISN). Compliance with the provisions of this paragraph shall be based on the measurement of the radio frequency voltage between each power line and ground at the power terminal. The lower limit applies at the boundary between the frequencies ranges.

Frequency of Emission (MHz)	Conducted Limit (dBuV)	
	Quasi-Peak	Average
0.15-0.5	66 to 56 <sup>Note 1</sup>	56 to 46 <sup>Note 2</sup>
0.5-5	56	46
5-30	60	50

*Note 1: Decreases with the logarithm of the frequency.*

*Note 2: A linear average detector is required*

### 6.2 EUT Setup

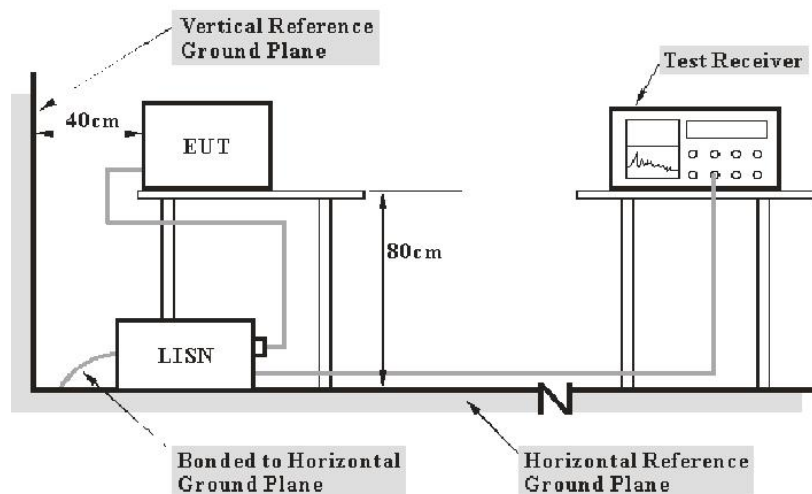

**Note:** 1. Support units were connected to second LISN.

2. Both of LISNs (AMN) 80 cm from EUT and at the least 30 cm from other units and other metal planes support units.

The setup of EUT is according with per ANSI C63.10-2013 measurement procedure. The specification used was with the FCC Part 15.207 limits.

### 6.3 EMI Test Receiver Setup

The EMI test receiver was set to investigate the spectrum from 150 kHz to 30 MHz. During the conducted emission test, the EMI test receiver was set with the following configurations

Frequency Range	Receiver RBW
150 kHz - 30 MHz	9 kHz

### 6.4 Test Procedure

During the conducted emission test, the adapter was connected to the outlet of the LISN. Maximizing procedure was performed on the six (6) highest emissions of the EUT. All data was recorded in the Quasi-peak and average detection mode.

### 6.5 Test Equipment List and Details

Manufacturers	Descriptions	Models	Serial Numbers	Calibration Date	Calibration Due Date
LISN	Rohde & Schwarz	ENV216	101612	2018/02/22	2019/02/21
LISN	Rohde & Schwarz	ENV216	101248	2018/06/27	2019/06/26
EMI Test Receiver	Rohde & Schwarz	ESR7	101419	2017/11/06	2018/11/05
Pulse Limiter	Rohde & Schwarz	ESH3Z2	TXZEM104	2018/08/03	2019/08/02
RF Cable	EMEC	EM-CB5D	001	2018/07/02	2019/07/01
Software	AUDIX	E3	V9.150826k	N.C.R	N.C.R

**\*Statement of Traceability:** The testing equipment's listed above have finished the calibration by Electronics Testing Center, Taiwan (ETC) or other laboratories which were accredited by TAF or equivalent organizations. The calibration result could be traceable to the International System of Units (SI).

### 6.6 Test Environmental Conditions

Temperature:	25 °C
Relative Humidity:	48 %
ATM Pressure:	1010 hPa

The testing was performed by Mars Chen on 2018-10-16.

### 6.7 AC Line Conducted Emission Test Plot and Data

Mode: AC 120V/60 Hz, BT mode, Line

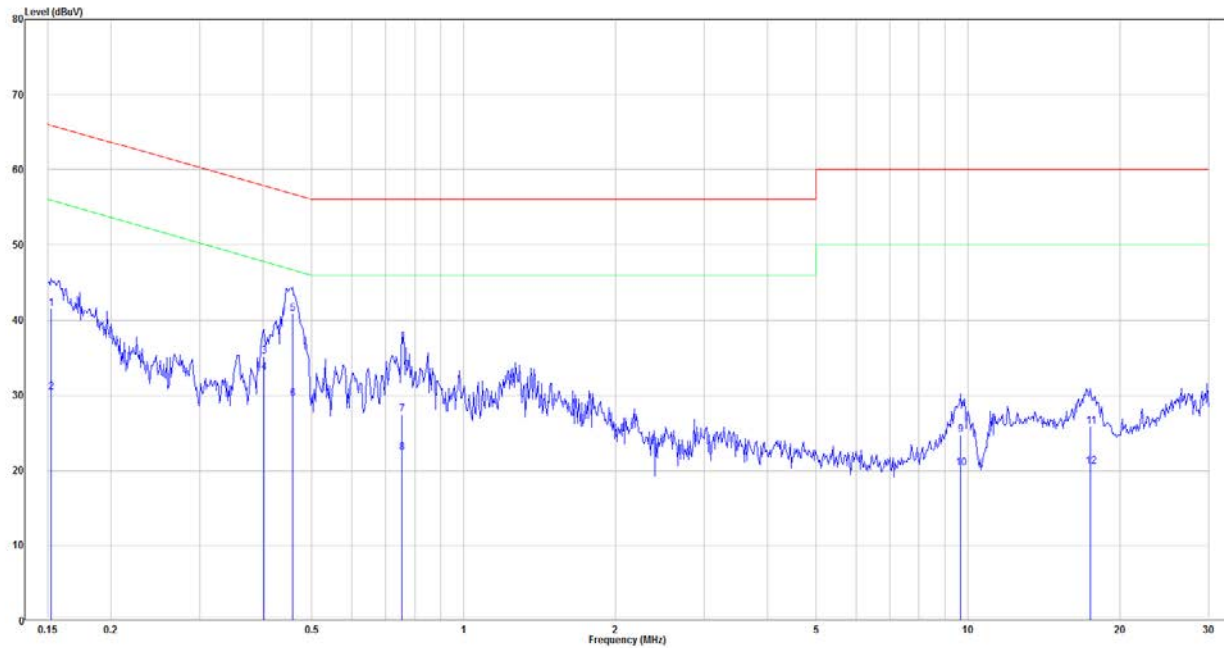

No.	Frequency (MHz)	Reading (dBuV)	Correct Factor(dB)	Result (dBuV)	Limit (dBuV)	Over limit (dB)	Remark
1	0.152	22.09	19.45	41.54	65.88	-24.34	QP
2	0.152	11.00	19.45	30.45	55.88	-25.43	Average
3	0.402	15.74	19.47	35.21	57.80	-22.59	QP
4	0.402	13.58	19.47	33.05	47.80	-14.76	Average
5	0.458	21.42	19.47	40.89	56.73	-15.83	QP
6	0.458	10.04	19.47	29.52	46.73	-17.21	Average
7	0.754	8.00	19.49	27.49	56.00	-28.51	QP
8	0.754	2.85	19.49	22.33	46.00	-23.67	Average
9	9.677	5.00	19.71	24.72	60.00	-35.28	QP
10	9.677	0.55	19.71	20.26	50.00	-29.74	Average
11	17.512	6.13	19.78	25.91	60.00	-34.09	QP
12	17.512	0.81	19.78	20.58	50.00	-29.42	Average

Note:

Level = Read Level + Factor

Over Limit (Margin) = Level – Limit Line

Factor = (LISN, ISN, PLC or current probe) Factor + Cable Loss + Attenuator



**Mode: AC 120V/60 Hz, BT mode, Neutral**

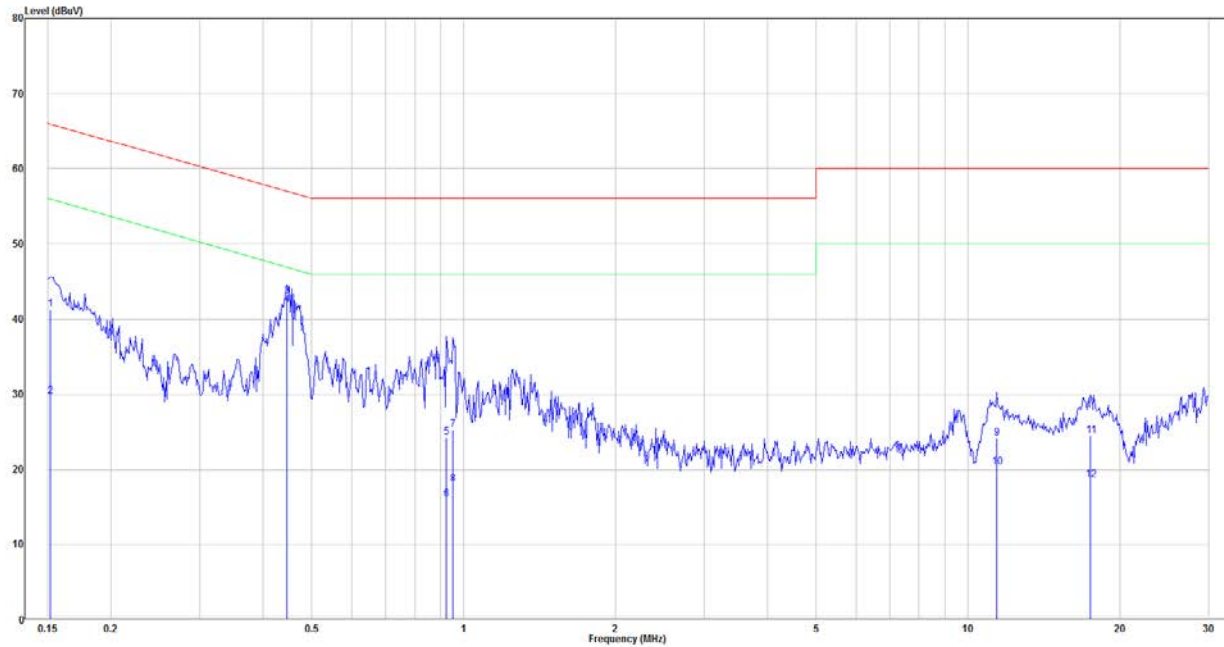

No.	Frequency (MHz)	Reading (dBuV)	Correct Factor(dB)	Result (dBuV)	Limit (dBuV)	Over limit (dB)	Remark
1	0.152	21.85	19.44	41.29	65.92	-24.63	QP
2	0.152	10.31	19.44	29.75	55.92	-26.17	Average
3	0.447	23.58	19.46	43.04	56.93	-13.89	QP
4	0.447	22.39	19.46	41.85	46.93	-5.08	Average
5	0.925	4.85	19.48	24.33	56.00	-31.67	QP
6	0.925	-3.46	19.48	16.02	46.00	-29.98	Average
7	0.953	5.80	19.48	25.28	56.00	-30.72	QP
8	0.953	-1.47	19.48	18.01	46.00	-27.99	Average
9	11.407	4.48	19.73	24.21	60.00	-35.79	QP
10	11.407	0.62	19.73	20.35	50.00	-29.65	Average
11	17.512	4.75	19.81	24.55	60.00	-35.45	QP
12	17.512	-1.18	19.81	18.63	50.00	-31.37	Average

Note:

Level = Read Level + Factor

Over Limit (Margin) = Level – Limit Line

Factor = (LISN, ISN, PLC or current probe) Factor + Cable Loss + Attenuator

## 7 FCC §15.209, §15.205, §15.247(d) – Spurious Emissions

### 7.1 Applicable Standard

As per FCC §15.35(d): Unless otherwise specified, on any frequency or frequencies above 1000 MHz, the radiated emission limits are based on the use of measurement instrumentation employing an average detector function. Unless otherwise specified, measurements above 1000 MHz shall be performed using a minimum resolution bandwidth of 1 MHz.

As Per FCC §15.205(a) except as show in paragraph (d) of this section, only spurious emissions are permitted in any of the frequency bands listed below:

MHz	MHz	MHz	GHz
0.090 – 0.110	16.42 – 16.423	960 – 1240	4. 5 – 5. 15
0.495 – 0.505	16.69475 – 16.69525	1300 – 1427	5. 35 – 5. 46
2.1735 – 2.1905	25.5 – 25.67	1435 – 1626.5	7.25 – 7.75
4.125 – 4.128	37.5 – 38.25	1645.5 – 1646.5	8.025 – 8.5
4.17725 – 4.17775	73 – 74.6	1660 – 1710	9.0 – 9.2
4.20725 – 4.20775	74.8 – 75.2	1718.8 – 1722.2	9.3 – 9.5
6.215 – 6.218	108 – 121.94	2200 – 2300	10.6 – 12.7
6.26775 – 6.26825	123 – 138	2310 – 2390	13.25 – 13.4
6.31175 – 6.31225	149.9 – 150.05	2483.5 – 2500	14.47 – 14.5
8.291 – 8.294	156.52475 –	2690 – 2900	15.35 – 16.2
8.362 – 8.366	156.52525	3260 – 3267	17.7 – 21.4
8.37625 – 8.38675	156.7 – 156.9	3.332 – 3.339	22.01 – 23.12
8.41425 – 8.41475	162.0125 –167.17	3 3458 – 3 358	23.6 – 24.0
12.29 – 12.293	167.72 – 173.2	3.600 – 4.400	31.2 – 31.8
12.51975 – 12.52025	240 – 285		36.43 – 36.5
12.57675 – 12.57725	322 – 335.4		Above 38.6
13.36 – 13.41	399.9 – 410		
	608 – 614		

As per FCC §15.209(a): Except as provided elsewhere in this Subpart, the emissions from an intentional radiator shall not exceed the field strength levels specified in the following table:

Frequency (MHz)	Field Strength (micro volts/meter)	Measurement Distance (meters)
0.009 - 0.490	2400/F(kHz)	300
0.490 - 1.705	24000/F(kHz)	30
1.705 - 30.0	30	30
30 - 88	100**	3
88 - 216	150**	3
216 - 960	200**	3
Above 960	500	3

\*\* Except as provided in paragraph (g), fundamental emissions from intentional radiators operating under this Section shall not be located in the frequency bands 54-72 MHz, 76-88 MHz, 174-216 MHz or 470-806 MHz. However, operation within these frequency bands is permitted under other sections of this Part, e.g., Sections 15.231 and 15.241.

As per FCC §15.247 (d) In any 100 kHz bandwidth outside the frequency band in which the spread spectrum or digitally modulated intentional radiator is operating, the radio frequency power that is produced by the intentional radiator shall be at least 20 dB below that in the 100 kHz bandwidth within the band that contains the highest level of the desired power, based on either an RF conducted or a radiated measurement, provided the transmitter demonstrates compliance with the peak conducted power limits. If the transmitter complies with the conducted power limits based on the use of RMS averaging over a time interval, as permitted under paragraph (b)(3) of this section, the attenuation required under this paragraph shall be 30 dB instead of 20 dB. Attenuation below the general limits specified in §15.209(a) is not required. In addition, radiated emissions which fall in the restricted bands, as defined in §15.205(a), must also comply with the radiated emission limits specified in §15.209(a) (see §15.205(c)).

### 7.2 EUT Setup

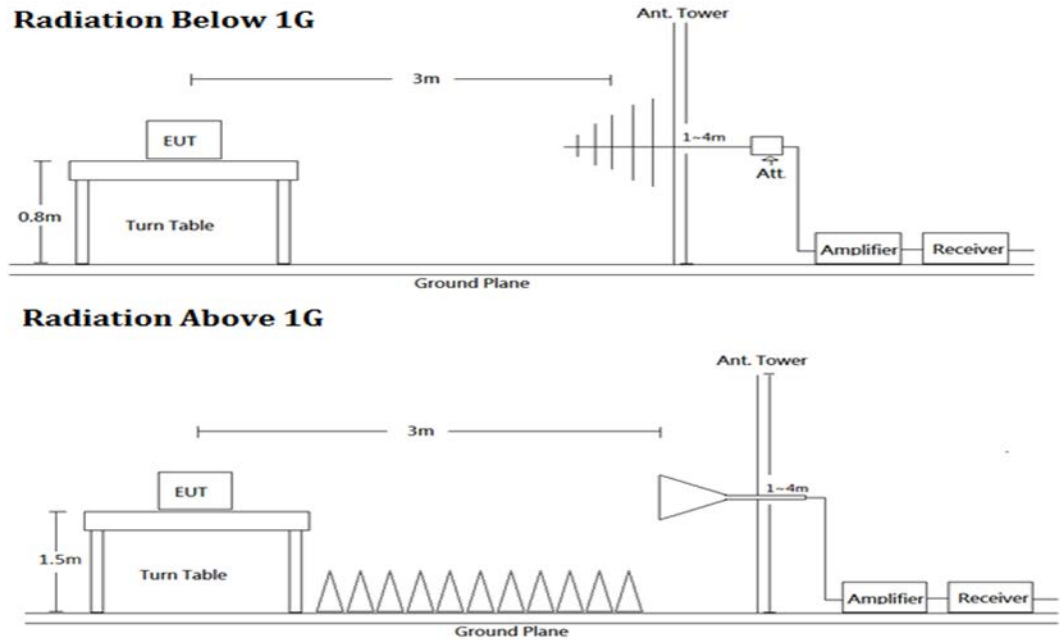

Radiated emission tests were performed in the 3 meters chamber test site, using the setup accordance with the ANSI C63.10-2013. The specification used was the FCC Part 15.209 and FCC 15.247 Limits.

### 7.3 EMI Test Receiver & Spectrum Analyzer Setup

The system was investigated from 30 MHz to 26.5 GHz. During the radiated emission test, the EMI test receiver was set with the following configurations measurement method 6.3 in ANSI C63.10.

Frequency Range	RBW	VBW	Measurement method
30-1000 MHz	120 kHz	/	QP
Above 1 GHz	1 MHz	3 MHz	PK
	1 MHz	10 Hz	Ave

## 7.4 Test Procedure

Maximizing procedure was performed on the highest emissions to ensure that the EUT complied with all installation combinations.

All data was recorded in the Quasi-peak detector mode from 30 MHz to 1 GHz and PK and average detector modes for frequencies above 1 GHz.

## 7.5 Test Equipment List and Details

Description	Manufacturer	Model	Serial Number	Calibration Date	Calibration Due Date
966A Room					
Bilog Antenna with 6 dB Attenuator	SUNOL SCIENCES & MINI-CIRCUITS	JB6/UNAT-6+	A050115/15542_01	2017/12/20	2018/12/19
Horn Antenna	EMCO	3115	9311-4158	2018/04/20	2019/04/19
Horn Antenna	ETS-Lindgren	3116	62638	2018/08/29	2019/08/28
Preamplifier	Sonoma	310N	130602	2018/07/04	2019/07/03
Preamplifier	EM Electronics Corp.	EM01G18G	060698	2018/04/13	2019/04/12
Microwave Preamplifier	EM Electronics Corporation	EM18G40G	060656	2018/01/15	2019/01/14
EMI Test Receiver	Rohde & Schwarz	ESR7	101419	2017/11/06	2018/11/05
Spectrum Analyzer	Rohde & Schwarz	FSV40	101435	2018/02/12	2019/02/13
Micro flex Cable	UTIFLEX	FSCM 64639 / (2M)	93D0127	2018/07/31	2019/07/30
Micro flex Cable	UTIFLEX	UFA210A-1-3149-300300	MFR64639 226389-001	2017/11/10	2018/11/09
Microflex Cable	ROSNOL	K1K50-UP0264-K1K50-80CM	160309-2	2018/01/17	2019/01/16
Microflex Cable	ROSNOL	K1K50-UP0264-K1K50-450CM	160309-1	2018/03/05	2019/03/04
20 dB Attenuator	NCL	BW-S20W5+	NA	Each Use	/
Turn Table	Champro	TT-2000	060772-T	N.C.R	N.C.R
Antenna Tower	Champro	AM-BS-4500-B	060772-A	N.C.R	N.C.R
Controller	Champro	EM1000	060772	N.C.R	N.C.R
Software	Farad	EZ EMC	BACL-03A1	N.C.R	N.C.R
Conducted Room					
Spectrum Analyzer	Rohde & Schwarz	FSU26	200268	2018/05/04	2019/05/03
Cable	WOKEN	SFL402	S02-160323-07	2018/02/12	2019/02/11

**\*Statement of Traceability:** The testing equipment's listed above have finished the calibration by Electronics Testing Center, Taiwan (ETC) or other laboratories which were accredited by TAF or equivalent organizations. The calibration result could be traceable to the International System of Units (SI).

## 7.6 Test Environmental Conditions

Temperature:	23.5 °C
Relative Humidity:	55.4 %
ATM Pressure:	1015 hPa

The testing was performed by Leo Cheng from 2018-09-17 to 2018-09-18.

### 7.7 Radiated Emission Test Plot and Data

**BT Mode:** Transmitting Mode (Pre-scan with three orthogonal axis, and worse case as X axis)

**Below 1G (30 MHz-1 GHz) test the output power worst mode: Worst case is EDR (8DPSK) Middle Channel**

**Horizontal**

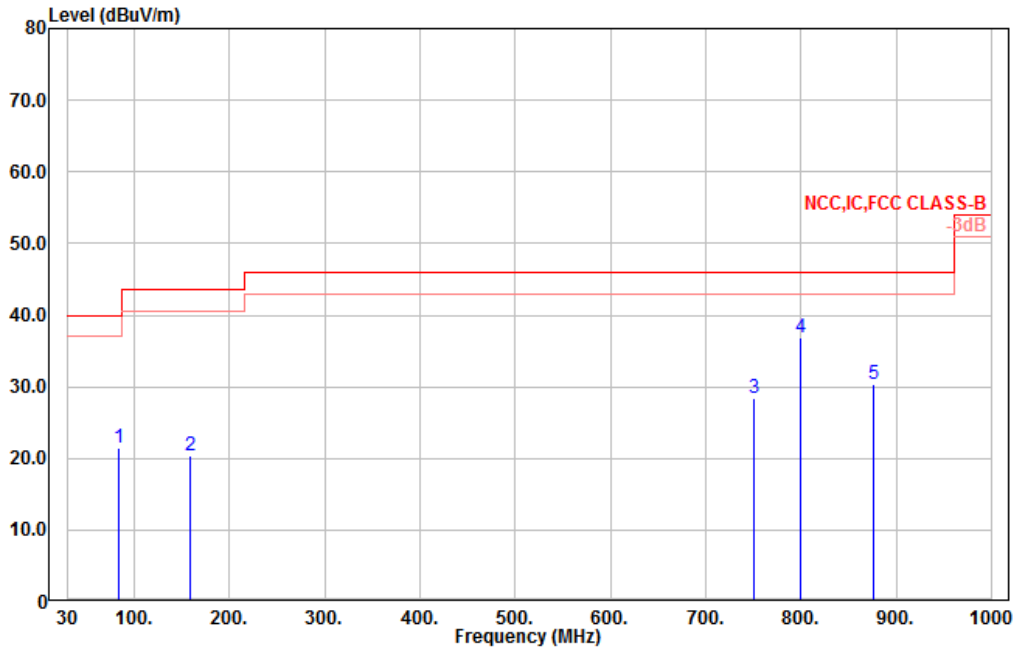

	Freq	Level	Limit	Over	Read		Remark	Pol/Phase
	MHz	dBuV/m	dBuV/m	dB	dBuV	dB/m		
1	83.350	21.41	40.00	-18.59	44.19	-22.78	Peak	horizontal
2	159.010	20.34	43.50	-23.16	38.97	-18.63	Peak	horizontal
3	750.710	28.46	46.00	-17.54	39.02	-10.56	Peak	horizontal
4	800.180	36.83	46.00	-9.17	46.65	-9.82	QP	horizontal
5	875.840	30.34	46.00	-15.66	39.29	-8.95	Peak	horizontal

**Vertical**

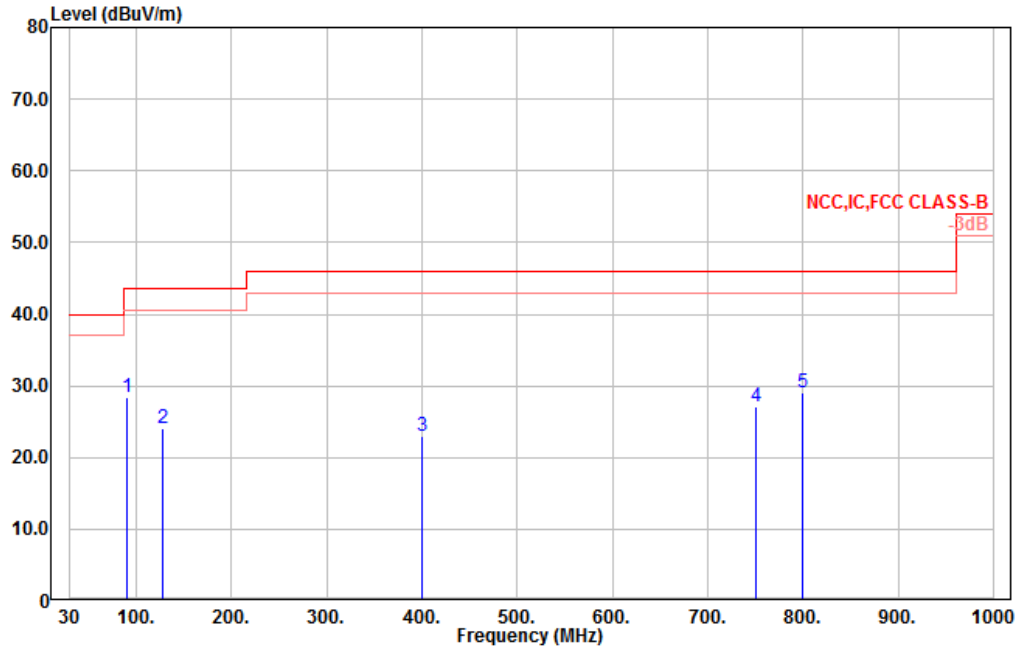

	Freq	Level	Limit	Over	Read		Remark	Pol/Phase
	MHz	dBuV/m	dBuV/m	dB	dBuV	dB/m		
1	91.110	28.42	43.50	-15.08	51.19	-22.77	Peak	vertical
2	127.970	23.97	43.50	-19.53	40.74	-16.77	Peak	vertical
3	399.570	23.00	46.00	-23.00	39.07	-16.07	Peak	vertical
4	750.710	27.14	46.00	-18.86	37.70	-10.56	Peak	vertical
5	800.180	29.04	46.00	-16.96	38.86	-9.82	Peak	vertical

**BR mode (GFSK):**

Low Channel													
Horizontal						Vertical							
Freq	Level	Limit Line	Over Limit	Read Level	Factor	Remark	Freq	Level	Limit Line	Over Limit	Read Level	Factor	Remark
MHz	dBuV/m	dBuV/m	dB	dBuV	dB/m		MHz	dBuV/m	dBuV/m	dB	dBuV	dB/m	
2341.500	35.93	54.00	-18.07	44.52	-8.59	Average	2357.400	35.84	54.00	-18.16	44.46	-8.62	Average
2341.500	51.30	74.00	-22.70	59.89	-8.59	Peak	2357.400	50.52	74.00	-23.48	59.14	-8.62	Peak
2401.800	80.20			88.92	-8.72	Average	2401.900	72.57			81.29	-8.72	Average
2401.800	92.44			101.16	-8.72	Peak	2401.900	82.93			91.65	-8.72	Peak
4804.000	30.44	54.00	-23.56	31.55	-1.11	Average	4804.000	30.40	54.00	-23.60	31.51	-1.11	Average
4804.000	43.59	74.00	-30.41	44.70	-1.11	Peak	4804.000	44.15	74.00	-29.85	45.26	-1.11	Peak
7206.000	32.91	54.00	-21.09	29.70	3.21	Average	7206.000	32.75	54.00	-21.25	29.54	3.21	Average
7206.000	46.62	74.00	-27.38	43.41	3.21	Peak	7206.000	46.70	74.00	-27.30	43.49	3.21	Peak

Mid Channel													
Horizontal						Vertical							
Freq	Level	Limit Line	Over Limit	Read Level	Factor	Remark	Freq	Level	Limit Line	Over Limit	Read Level	Factor	Remark
MHz	dBuV/m	dBuV/m	dB	dBuV	dB/m		MHz	dBuV/m	dBuV/m	dB	dBuV	dB/m	
2358.960	35.89	54.00	-18.11	44.51	-8.62	Average	2386.320	35.78	54.00	-18.22	44.47	-8.69	Average
2358.960	50.31	74.00	-23.69	58.93	-8.62	Peak	2386.320	49.64	74.00	-24.36	58.33	-8.69	Peak
2441.040	78.70			87.46	-8.76	Average	2441.280	67.89			76.65	-8.76	Average
2441.040	90.63			99.39	-8.76	Peak	2441.280	77.26			86.02	-8.76	Peak
2537.520	35.93	54.00	-18.07	44.67	-8.74	Average	2496.480	35.92	54.00	-18.08	44.72	-8.80	Average
2537.520	50.20	74.00	-23.80	58.94	-8.74	Peak	2496.480	50.29	74.00	-23.71	59.09	-8.80	Peak
4882.000	30.57	54.00	-23.43	31.45	-0.88	Average	4882.000	30.73	54.00	-23.27	31.59	-0.86	Average
4882.000	43.08	74.00	-30.92	43.96	-0.88	Peak	4882.000	42.60	74.00	-31.40	43.46	-0.86	Peak
7323.000	33.52	54.00	-20.48	29.97	3.55	Average	7323.000	33.22	54.00	-20.78	29.67	3.55	Average
7323.000	46.99	74.00	-27.01	43.44	3.55	Peak	7323.000	46.65	74.00	-27.35	43.10	3.55	Peak

High Channel													
Horizontal						Vertical							
Freq	Level	Limit Line	Over Limit	Read Level	Factor	Remark	Freq	Level	Limit Line	Over Limit	Read Level	Factor	Remark
MHz	dBuV/m	dBuV/m	dB	dBuV	dB/m		MHz	dBuV/m	dBuV/m	dB	dBuV	dB/m	
2479.840	77.03			85.81	-8.78	Average	2480.160	65.70			74.48	-8.78	Average
2479.840	88.49			97.27	-8.78	Peak	2480.160	74.52			83.30	-8.78	Peak
2528.560	35.97	54.00	-18.03	44.75	-8.78	Average	2499.440	35.88	54.00	-18.12	44.69	-8.81	Average
2528.560	50.80	74.00	-23.20	59.56	-8.76	Peak	2499.440	50.67	74.00	-23.33	59.48	-8.81	Peak
4960.000	30.83	54.00	-23.17	31.57	-0.74	Average	4960.000	30.81	54.00	-23.19	31.55	-0.74	Average
4960.000	43.29	74.00	-30.71	44.03	-0.74	Peak	4960.000	44.12	74.00	-29.88	44.86	-0.74	Peak
7440.000	33.64	54.00	-20.36	29.67	3.97	Average	7440.000	33.62	54.00	-20.38	29.65	3.97	Average
7440.000	46.45	74.00	-27.55	42.48	3.97	Peak	7440.000	46.68	74.00	-27.32	42.71	3.97	Peak

Result = Reading + Correct Factor

Margin = Result – Limit

Correct Factor = Antenna Factor + Cable Loss – Amplifier Gain

Spurious emissions more than 20 dB below the limit were not reported

**EDR mode ( $\pi/4$ -DQPSK):**

Low Channel													
Horizontal							Vertical						
Freq	Level	Limit	Over	Read			Freq	Level	Limit	Over	Read		
		Line	Limit	Level	Factor	Remark			Line	Limit	Level	Factor	Remark
MHz	dBuV/m	dBuV/m	dB	dBuV	dB/m		MHz	dBuV/m	dBuV/m	dB	dBuV	dB/m	
2337.900	35.96	54.00	-18.04	44.54	-8.58	Average	2333.500	35.91	54.00	-18.09	44.47	-8.56	Average
2337.900	50.32	74.00	-23.68	58.90	-8.58	Peak	2333.500	50.68	74.00	-23.32	59.24	-8.56	Peak
2401.900	74.15			82.87	-8.72	Average	2402.200	65.86			74.58	-8.72	Average
2401.900	88.19			96.91	-8.72	Peak	2402.200	77.81			86.53	-8.72	Peak
4804.000	30.18	54.00	-23.82	31.29	-1.11	Average	4804.000	30.55	54.00	-23.45	31.66	-1.11	Average
4804.000	42.50	74.00	-31.50	43.61	-1.11	Peak	4804.000	42.55	74.00	-31.45	43.66	-1.11	Peak
7206.000	33.05	54.00	-20.95	29.84	3.21	Average	7206.000	32.97	54.00	-21.03	29.76	3.21	Average
7206.000	46.36	74.00	-27.64	43.15	3.21	Peak	7206.000	45.96	74.00	-28.04	42.75	3.21	Peak

Mid Channel													
Horizontal							Vertical						
Freq	Level	Limit	Over	Read			Freq	Level	Limit	Over	Read		
		Line	Limit	Level	Factor	Remark			Line	Limit	Level	Factor	Remark
MHz	dBuV/m	dBuV/m	dB	dBuV	dB/m		MHz	dBuV/m	dBuV/m	dB	dBuV	dB/m	
2373.360	35.83	54.00	-18.17	44.49	-8.66	Average	2373.120	35.79	54.00	-18.21	44.45	-8.66	Average
2373.360	49.39	74.00	-24.61	58.05	-8.66	Peak	2373.120	49.65	74.00	-24.35	58.31	-8.66	Peak
2440.800	72.79			81.55	-8.76	Average	2440.800	61.98			70.74	-8.76	Average
2440.800	86.34			95.10	-8.76	Peak	2440.800	72.95			81.71	-8.76	Peak
2515.200	35.91	54.00	-18.09	44.69	-8.78	Average	2489.520	35.86	54.00	-18.14	44.65	-8.79	Average
2515.200	49.83	74.00	-24.17	58.61	-8.78	Peak	2489.520	49.53	74.00	-24.47	58.32	-8.79	Peak
4882.000	30.56	54.00	-23.44	31.44	-0.88	Average	4882.000	30.70	54.00	-23.30	31.58	-0.88	Average
4882.000	42.95	74.00	-31.05	43.83	-0.88	Peak	4882.000	42.36	74.00	-31.64	43.24	-0.88	Peak
7323.000	33.43	54.00	-20.57	29.88	3.55	Average	7323.000	33.21	54.00	-20.79	29.66	3.55	Average
7323.000	46.99	74.00	-27.01	43.44	3.55	Peak	7323.000	47.24	74.00	-26.76	43.69	3.55	Peak

High Channel													
Horizontal							Vertical						
Freq	Level	Limit	Over	Read			Freq	Level	Limit	Over	Read		
		Line	Limit	Level	Factor	Remark			Line	Limit	Level	Factor	Remark
MHz	dBuV/m	dBuV/m	dB	dBuV	dB/m		MHz	dBuV/m	dBuV/m	dB	dBuV	dB/m	
2479.840	70.99			79.77	-8.78	Average	2480.000	62.78			71.56	-8.78	Average
2479.840	84.18			92.96	-8.78	Peak	2480.000	73.97			82.75	-8.78	Peak
2525.040	35.97	54.00	-18.03	44.73	-8.76	Average	2517.040	35.97	54.00	-18.03	44.75	-8.78	Average
2525.040	50.76	74.00	-23.24	59.52	-8.76	Peak	2517.040	50.78	74.00	-23.22	59.56	-8.78	Peak
4960.000	30.72	54.00	-23.28	31.46	-0.74	Average	4960.000	30.76	54.00	-23.24	31.50	-0.74	Average
4960.000	43.26	74.00	-30.74	44.00	-0.74	Peak	4960.000	43.16	74.00	-30.84	43.90	-0.74	Peak
7440.000	33.49	54.00	-20.51	29.52	3.97	Average	7440.000	33.69	54.00	-20.31	29.72	3.97	Average
7440.000	47.00	74.00	-27.00	43.03	3.97	Peak	7440.000	46.50	74.00	-27.50	42.53	3.97	Peak

Result = Reading + Correct Factor

Margin = Result – Limit

Correct Factor = Antenna Factor + Cable Loss – Amplifier Gain

Spurious emissions more than 20 dB below the limit were not reported



**EDR mode (8-DPSK):**

Low Channel													
Horizontal							Vertical						
Freq	Level	Limit	Over	Read			Freq	Level	Limit	Over	Read		
		Line	Limit	Level	Factor	Remark			Line	Limit	Level	Factor	Remark
MHz	dBuV/m	dBuV/m	dB	dBuV	dB/m		MHz	dBuV/m	dBuV/m	dB	dBuV	dB/m	
2355.000	35.91	54.00	-18.09	44.53	-8.62	Average	2334.600	35.90	54.00	-18.10	44.47	-8.57	Average
2355.000	49.81	74.00	-24.19	58.43	-8.62	Peak	2334.600	50.51	74.00	-23.49	59.08	-8.57	Peak
2402.000	74.47			83.19	-8.72	Average	2402.000	62.49			71.21	-8.72	Average
2402.000	88.90			97.62	-8.72	Peak	2402.000	73.93			82.65	-8.72	Peak
4804.000	30.56	54.00	-23.44	31.67	-1.11	Average	4804.000	30.75	54.00	-23.25	31.86	-1.11	Average
4804.000	42.86	74.00	-31.14	43.97	-1.11	Peak	4804.000	43.07	74.00	-30.93	44.18	-1.11	Peak
7206.000	32.88	54.00	-21.12	29.67	3.21	Average	7206.000	32.88	54.00	-21.12	29.67	3.21	Average
7206.000	45.72	74.00	-28.28	42.51	3.21	Peak	7206.000	45.83	74.00	-28.17	42.62	3.21	Peak

Mid Channel													
Horizontal							Vertical						
Freq	Level	Limit	Over	Read			Freq	Level	Limit	Over	Read		
		Line	Limit	Level	Factor	Remark			Line	Limit	Level	Factor	Remark
MHz	dBuV/m	dBuV/m	dB	dBuV	dB/m		MHz	dBuV/m	dBuV/m	dB	dBuV	dB/m	
2350.080	35.86	54.00	-18.14	44.47	-8.61	Average	2322.720	35.94	54.00	-18.06	44.49	-8.55	Average
2350.080	50.04	74.00	-23.96	58.65	-8.61	Peak	2322.720	49.75	74.00	-24.25	58.30	-8.55	Peak
2441.040	73.04			81.80	-8.76	Average	2441.040	62.18			70.94	-8.76	Average
2441.040	87.09			95.85	-8.76	Peak	2441.040	73.52			82.28	-8.76	Peak
2546.160	35.91	54.00	-18.09	44.63	-8.72	Average	2497.440	35.80	54.00	-18.20	44.61	-8.81	Average
2546.160	51.07	74.00	-22.93	59.79	-8.72	Peak	2497.440	50.15	74.00	-23.85	58.96	-8.81	Peak
4882.000	30.93	54.00	-23.07	31.81	-0.88	Average	4882.000	30.89	54.00	-23.11	31.77	-0.88	Average
4882.000	44.30	74.00	-29.70	45.18	-0.88	Peak	4882.000	42.82	74.00	-31.18	43.70	-0.88	Peak
7323.000	33.22	54.00	-20.78	29.67	3.55	Average	7323.000	33.30	54.00	-20.70	29.75	3.55	Average
7323.000	47.44	74.00	-26.56	43.89	3.55	Peak	7323.000	46.97	74.00	-27.03	43.42	3.55	Peak

High Channel													
Horizontal							Vertical						
Freq	Level	Limit	Over	Read			Freq	Level	Limit	Over	Read		
		Line	Limit	Level	Factor	Remark			Line	Limit	Level	Factor	Remark
MHz	dBuV/m	dBuV/m	dB	dBuV	dB/m		MHz	dBuV/m	dBuV/m	dB	dBuV	dB/m	
2480.000	60.51			69.29	-8.78	Average	2480.000	60.51			69.29	-8.78	Average
2480.000	72.26			81.04	-8.78	Peak	2480.000	72.26			81.04	-8.78	Peak
2515.040	35.92	54.00	-18.08	44.70	-8.78	Average	2515.040	35.92	54.00	-18.08	44.70	-8.78	Average
2515.040	50.38	74.00	-23.62	59.16	-8.78	Peak	2515.040	50.38	74.00	-23.62	59.16	-8.78	Peak
4960.000	30.81	54.00	-23.19	31.55	-0.74	Average	4960.000	30.81	54.00	-23.19	31.55	-0.74	Average
4960.000	43.54	74.00	-30.46	44.28	-0.74	Peak	4960.000	43.54	74.00	-30.46	44.28	-0.74	Peak
7440.000	33.43	54.00	-20.57	29.46	3.97	Average	7440.000	33.43	54.00	-20.57	29.46	3.97	Average
7440.000	47.19	74.00	-26.81	43.22	3.97	Peak	7440.000	47.19	74.00	-26.81	43.22	3.97	Peak

Result = Reading + Correct Factor

Margin = Result - Limit

Correct Factor = Antenna Factor + Cable Loss - Amplifier Gain

Spurious emissions more than 20 dB below the limit were not reported

Above 1G (1 GHz-26.5 GHz) test the output power worst mode: Worst case is BR mode (GFSK) High channel)

**Horizontal**

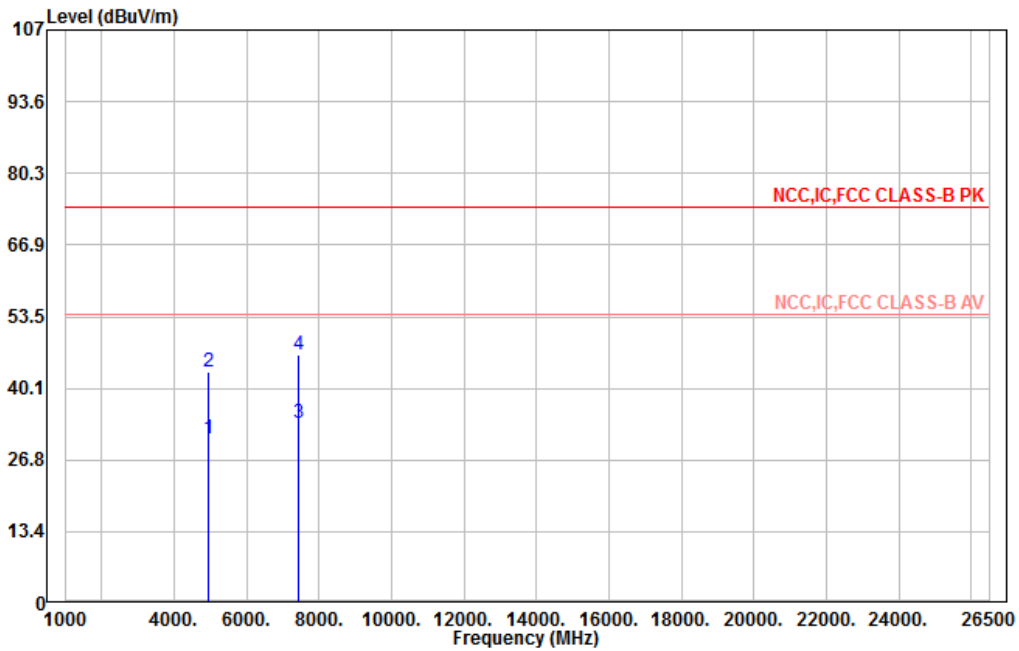

	Freq	Level	Limit	Over	Read		Remark	Pol/Phase
	MHz	dBuV/m	dBuV/m	Limit	Level	Factor		
				dB	dBuV	dB/m		
1	4960.000	30.83	54.00	-23.17	31.57	-0.74	Average	horizontal
2	4960.000	43.29	74.00	-30.71	44.03	-0.74	Peak	horizontal
3	7440.000	33.64	54.00	-20.36	29.67	3.97	Average	horizontal
4	7440.000	46.45	74.00	-27.55	42.48	3.97	Peak	horizontal

**Vertical**

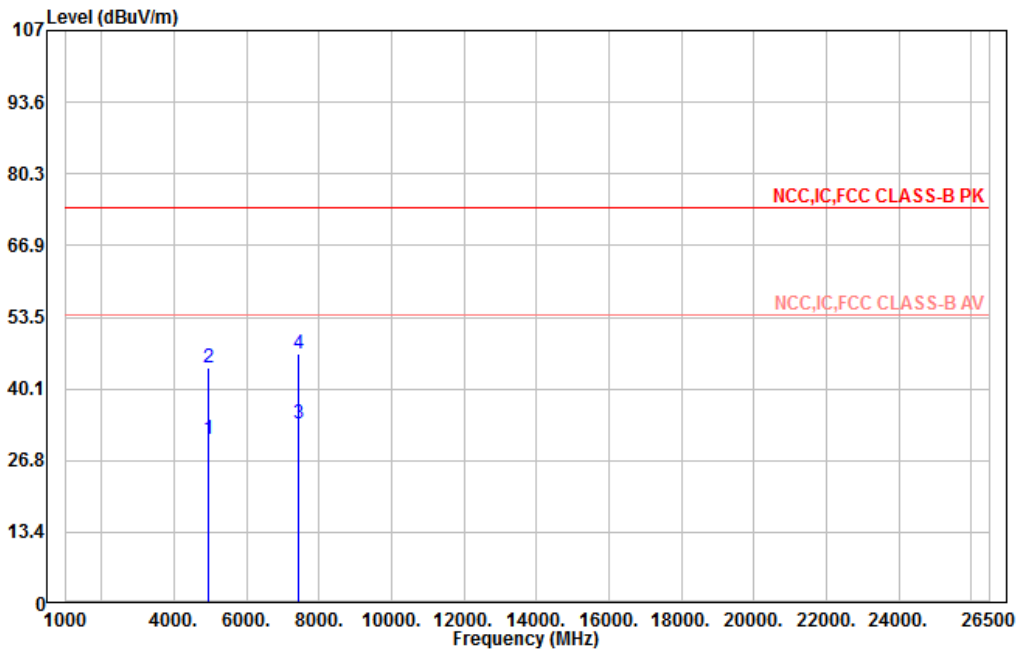

	Freq	Level	Limit	Over	Read		Remark	Pol/Phase
	MHz	dBuV/m	dBuV/m	dB	dBuV	dB/m		
1	4960.000	30.81	54.00	-23.19	31.55	-0.74	Average	vertical
2	4960.000	44.12	74.00	-29.88	44.86	-0.74	Peak	vertical
3	7440.000	33.62	54.00	-20.38	29.65	3.97	Average	vertical
4	7440.000	46.68	74.00	-27.32	42.71	3.97	Peak	vertical

**Conducted Spurious Emissions:**

Channel	Frequency (MHz)	Delta Peak to Band Emission (dBc)	Limit (dBc)	Result
<b>BR mode (GFSK)</b>				
Low	2402	42.49	≥ 20	Compliance
Mid	2441	40.32	≥ 20	Compliance
High	2480	39.78	≥ 20	Compliance
<b>EDR mode (<math>\pi/4</math>-DQPSK)</b>				
Low	2402	36.14	≥ 20	Compliance
Mid	2441	33.29	≥ 20	Compliance
High	2480	33.24	≥ 20	Compliance
<b>EDR mode (8DPSK)</b>				
Low	2402	39.07	≥ 20	Compliance
Mid	2441	37.82	≥ 20	Compliance
High	2480	36.55	≥ 20	Compliance

Please refer to the following plots

**BR mode (GFSK):**

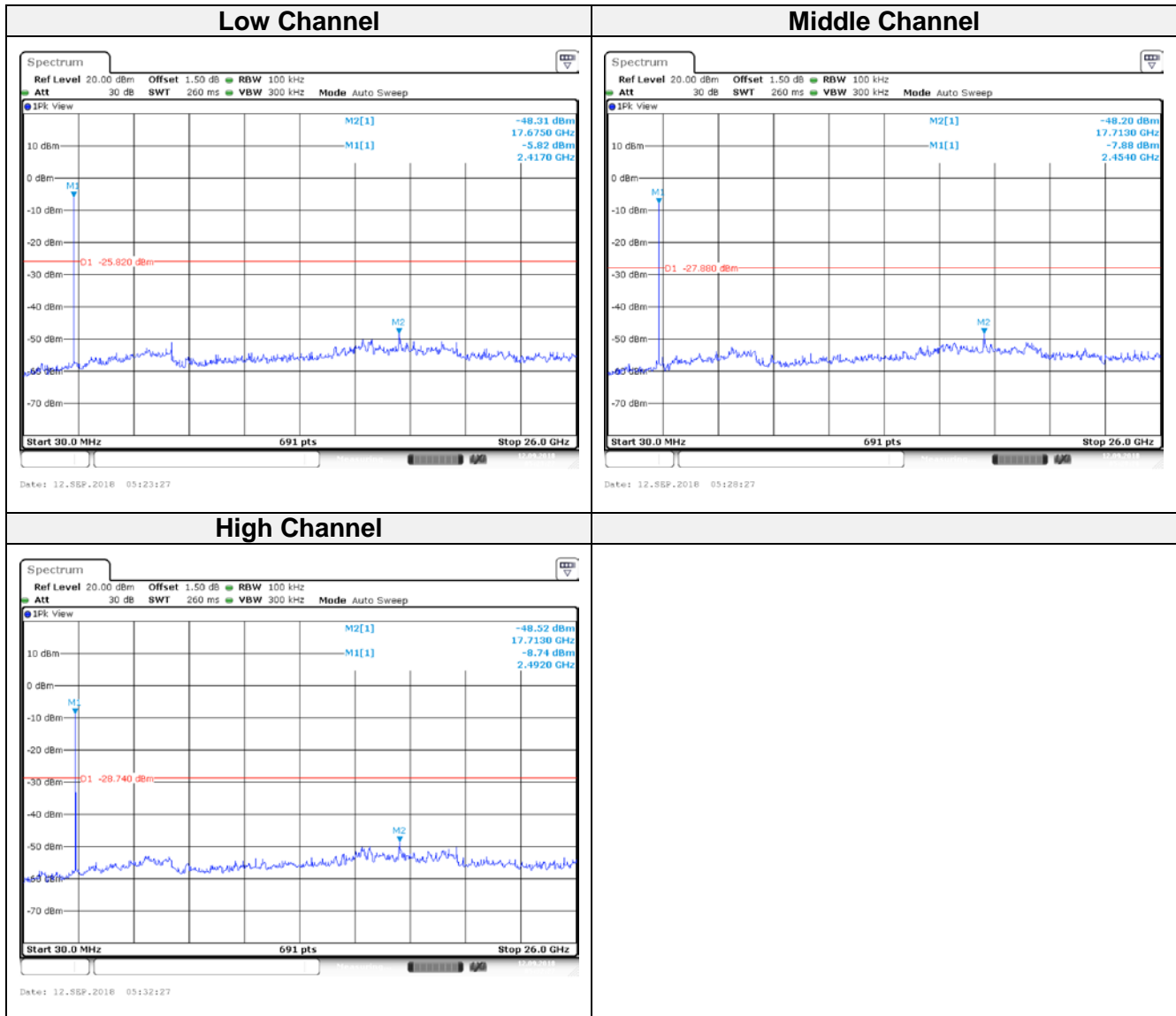

**EDR mode ( $\pi/4$ -DQPSK):**

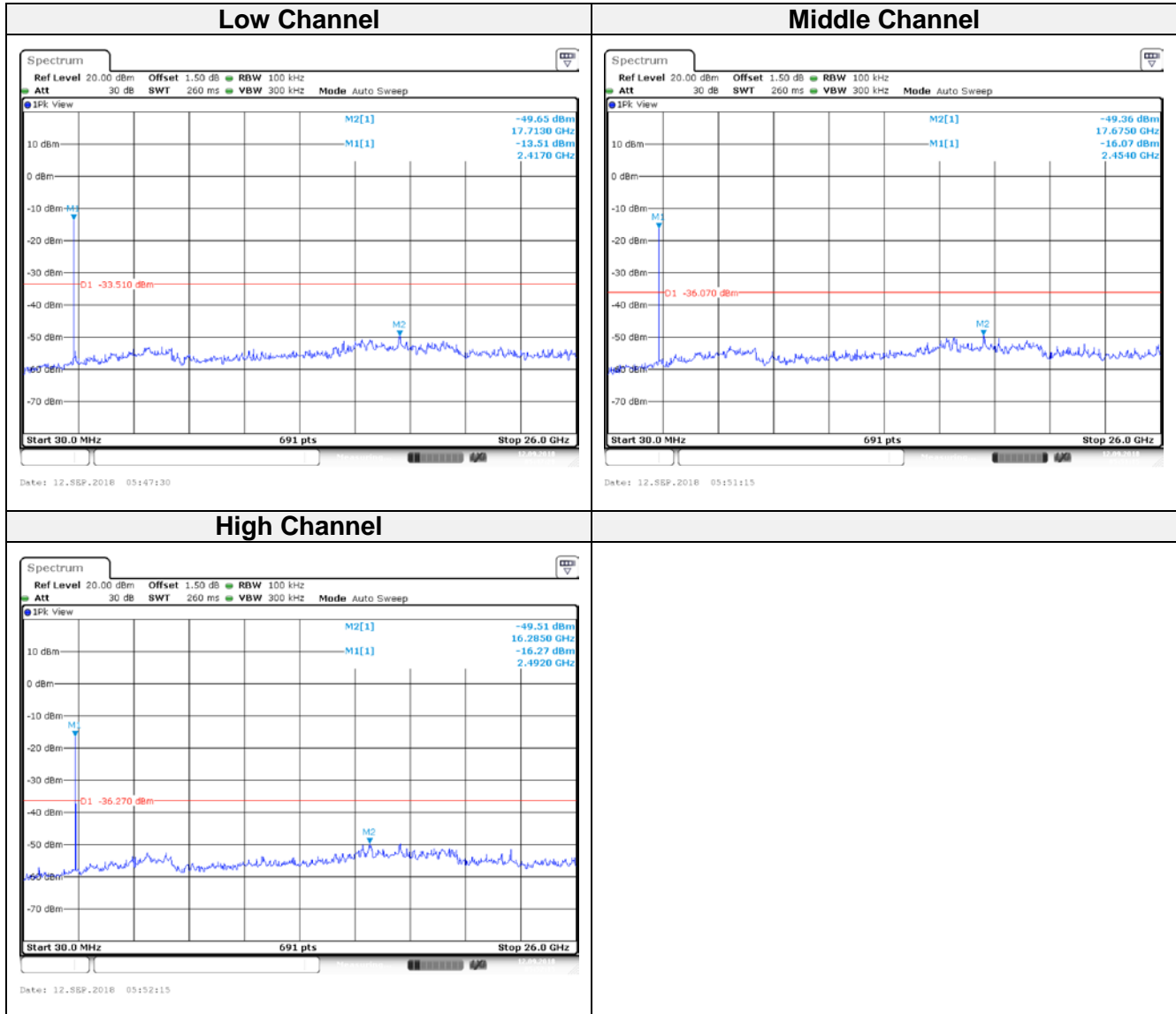

**EDR mode (8DPSK):**

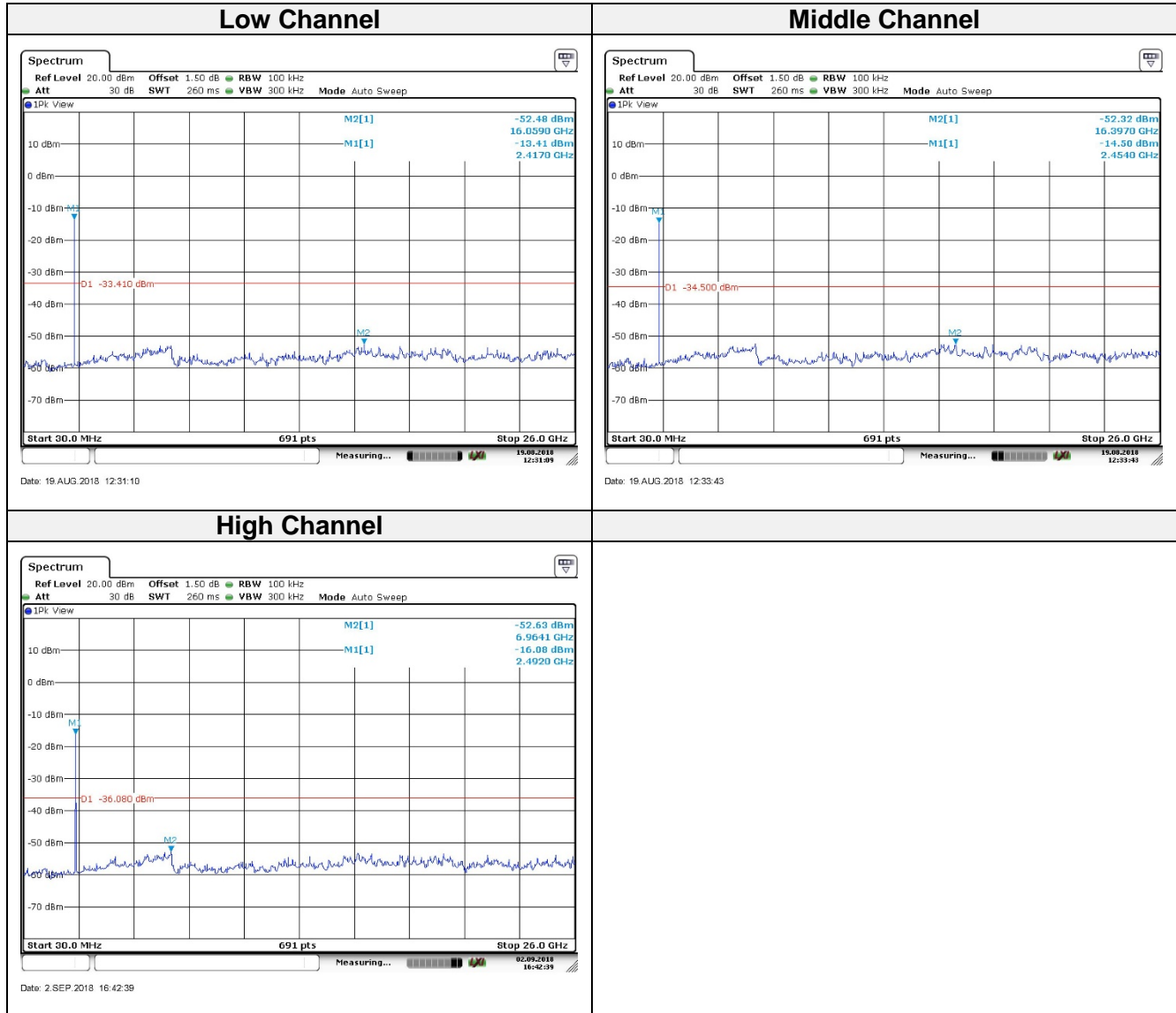

## 8 FCC §15.247(a)(1) – 20 dB Emission Bandwidth

### 8.1 Applicable Standard

According to FCC §15.247(a) (1) the maximum 20 dB bandwidth of the hopping channel shall be presented.

### 8.2 Test Procedure

- (1) Check the calibration of the measuring instrument using either an internal calibrator or a known signal from an external generator.
- (2) Position the EUT without connection to measurement instrument. Turn on the EUT and connect it to measurement instrument. Then set it to any one convenient frequency within its operating range. Set a reference level on the measuring instrument equal to the highest peak value.
- (3) Measure the frequency difference of two frequencies that were attenuated 20 dB from the reference level. Record the frequency difference as the emission bandwidth.
- (4) Repeat above procedures until all frequencies measured were complete.

### 8.3 Test Equipment List and Details

Descriptions	Manufacturers	Models	Serial Numbers	Calibration Date	Calibration Due Date
Spectrum Analyzer	Rohde & Schwarz	FSV40	101140	2017/11/15	2018/11/14
Cable	WOKEN	SFL402	S02-160323-07	2018/02/12	2019/02/11

**\*Statement of Traceability:** The testing equipment's listed above have finished the calibration by Electronics Testing Center, Taiwan (ETC) or other laboratories which were accredited by TAF or equivalent organizations. The calibration result could be traceable to the International System of Units (SI).

### 8.4 Test Environmental Conditions

Temperature:	25.2 °C
Relative Humidity:	54 %
ATM Pressure:	1015 hPa

The testing was performed by Eric Lee from 2018-08-19 to 2018-09-27.



## 8.5 Test Results

Channel	Frequency (MHz)	20 dB OBW (MHz)
<b>BR Mode (GFSK)</b>		
Low	2402	1.0029
Middle	2441	1.0072
High	2480	1.0029
<b>EDR Mode (<math>\pi/4</math>-DQPSK)</b>		
Low	2402	1.3589
Middle	2441	1.3589
High	2480	1.3589
<b>EDR Mode (8DPSK)</b>		
Low	2402	1.3285
Middle	2441	1.3285
High	2480	1.3242

Please refer to the following plots

**BR Mode (GFSK):**

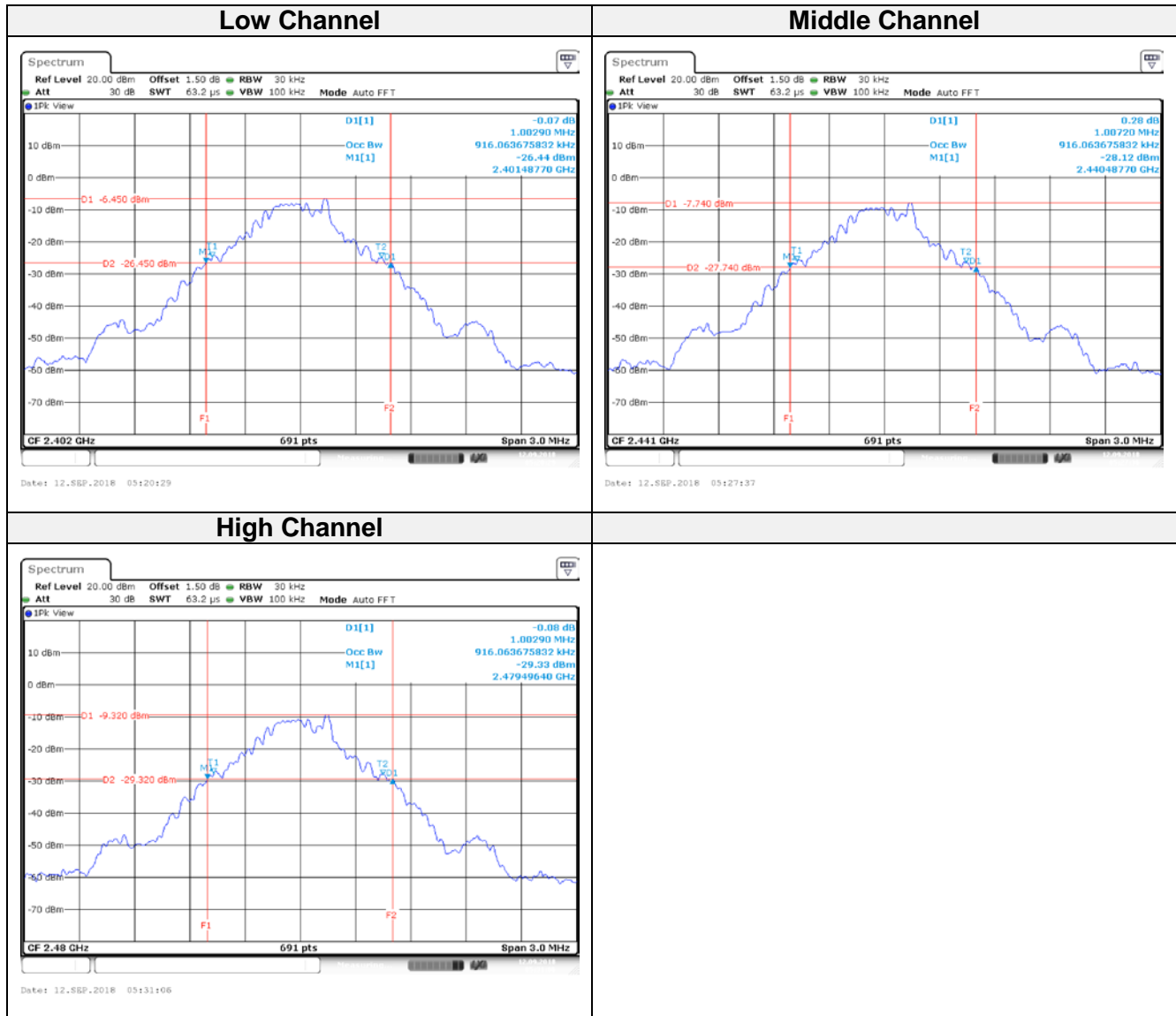

**EDR Mode ( $\pi/4$ -DQPSK):**

**Low Channel**

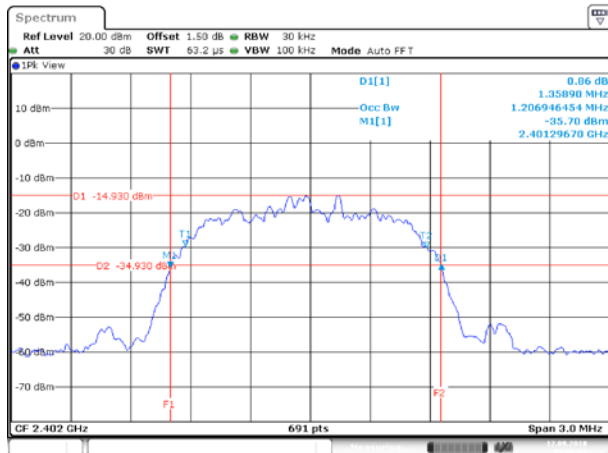

**Middle Channel**

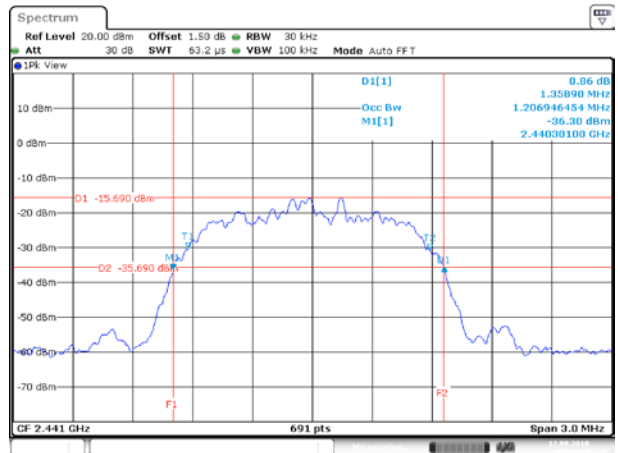

**High Channel**

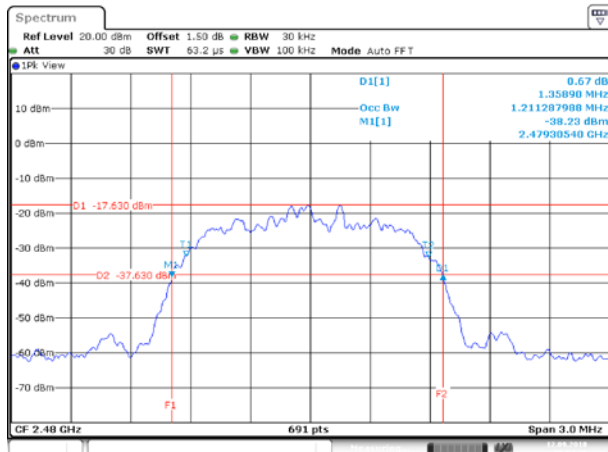

**EDR Mode (8DPSK):**

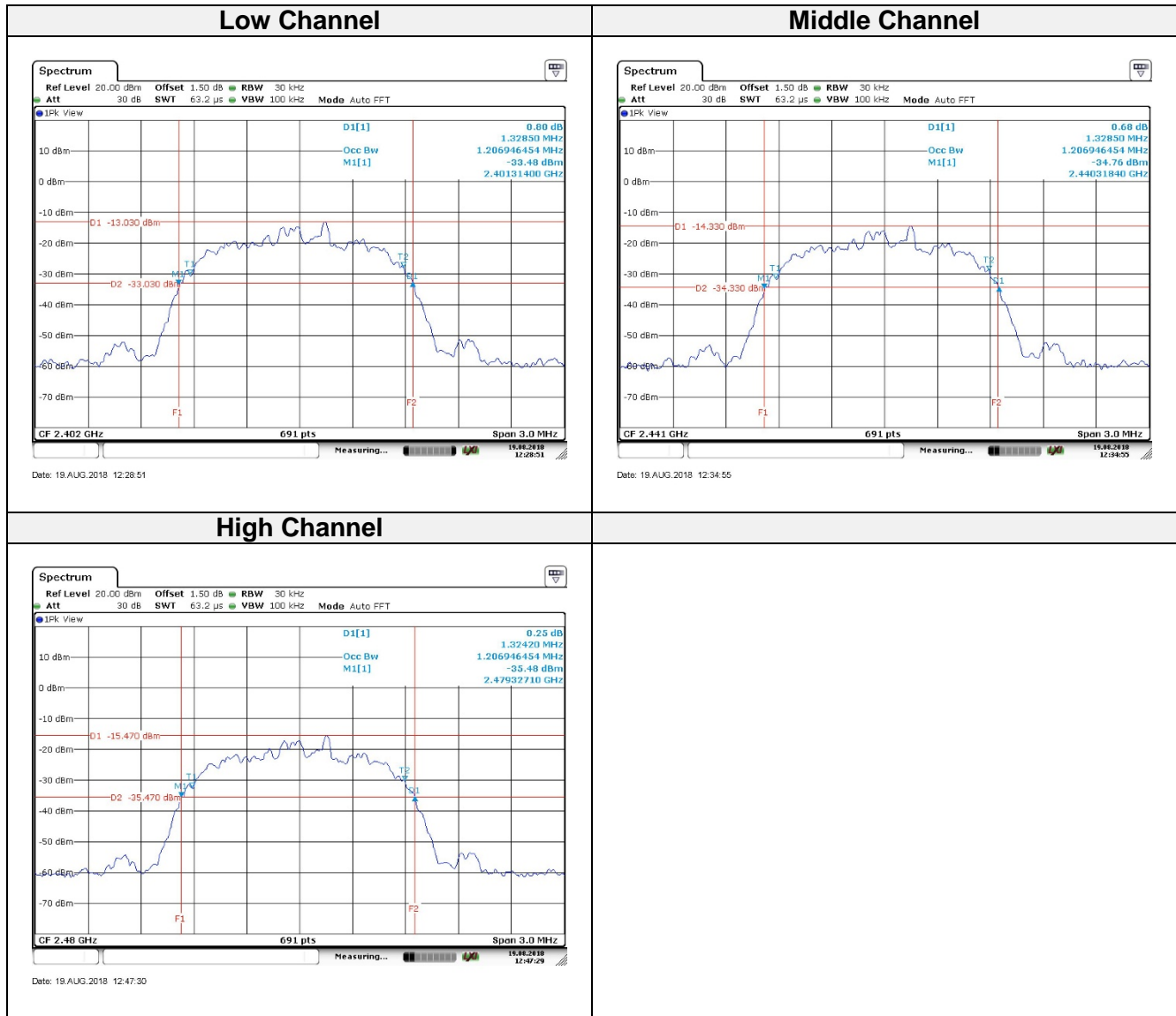

## 9 FCC §15.247(a)(1) – Channel Separation Test

### 9.1 Applicable Standard

According to FCC §15.247(a) (1): Frequency hopping systems shall have hopping channel carrier frequencies separated by a minimum of 25 kHz or the 20 dB bandwidth of the hopping channel, whichever is greater. Alternatively, frequency hopping systems operating in the 2400-2483.5 MHz band may have hopping channel carrier frequencies that are separated by 25 kHz or two-thirds of the 20 dB bandwidth of the hopping channel, whichever is greater, provided the systems operate with an output power no greater than 125 mW. The system shall hop to channel frequencies that are selected at the system hopping rate from a pseudo randomly ordered list of hopping frequencies. Each frequency must be used equally on the average by each transmitter. The system receivers shall have input bandwidths that match the hopping channel bandwidths of their corresponding transmitters and shall shift frequencies in synchronization with the transmitted signals.

### 9.2 Test Procedure

Span = wide enough to capture the peaks of two adjacent channels

Resolution (or IF) Bandwidth (RBW)  $\approx$  30% of the channel spacing, adjust as necessary to best identify the center of each individual channel

Video (or Average) Bandwidth (VBW)  $\geq$  RBW

Sweep = auto

Detector function = peak Trace = max hold

### 9.3 Test Equipment List and Details

Descriptions	Manufacturers	Models	Serial Numbers	Calibration Date	Calibration Due Date
Spectrum Analyzer	Rohde & Schwarz	FSV40	101140	2017/11/15	2018/11/14
Cable	WOKEN	SFL402	S02-160323-07	2018/02/12	2019/02/11

*\*Statement of Traceability: The testing equipment's listed above have finished the calibration by Electronics Testing Center, Taiwan (ETC) or other laboratories which were accredited by TAF or equivalent organizations. The calibration result could be traceable to the International System of Units (SI).*

### 9.4 Test Environmental Conditions

Temperature:	25.2 °C
Relative Humidity:	54 %
ATM Pressure:	1015 hPa

*The testing was performed by Eric Lee from 2018-08-19 to 2018-09-27.*

**9.5 Test Results**

Channel	Channel Separation (MHz)	20 dBc BW (MHz)	Two-thirds of the 20 dB bandwidth (MHz)	Limit (dBm)	Result
<b>BR mode (GFSK)</b>					
Low	0.9986	1.0029	0.669	>two-thirds of the 20 dB bandwidth	Compliance
Middle	0.9986	1.0072	0.671	>two-thirds of the 20 dB bandwidth	Compliance
High	0.9986	1.0029	0.669	>two-thirds of the 20 dB bandwidth	Compliance
<b>EDR mode (<math>\pi</math>4-DQPSK)</b>					
Low	0.9986	1.3589	0.906	>two-thirds of the 20 dB bandwidth	Compliance
Middle	0.9986	1.3589	0.906	>two-thirds of the 20 dB bandwidth	Compliance
High	0.9986	1.3589	0.906	>two-thirds of the 20 dB bandwidth	Compliance
<b>EDR mode (8DPSK)</b>					
Low	0.9986	1.3285	0.886	>two-thirds of the 20 dB bandwidth	Compliance
Middle	0.9986	1.3285	0.886	>two-thirds of the 20 dB bandwidth	Compliance
High	0.9986	1.3242	0.883	>two-thirds of the 20 dB bandwidth	Compliance

Please refer to the following plots

**BR mode (GFSK):**

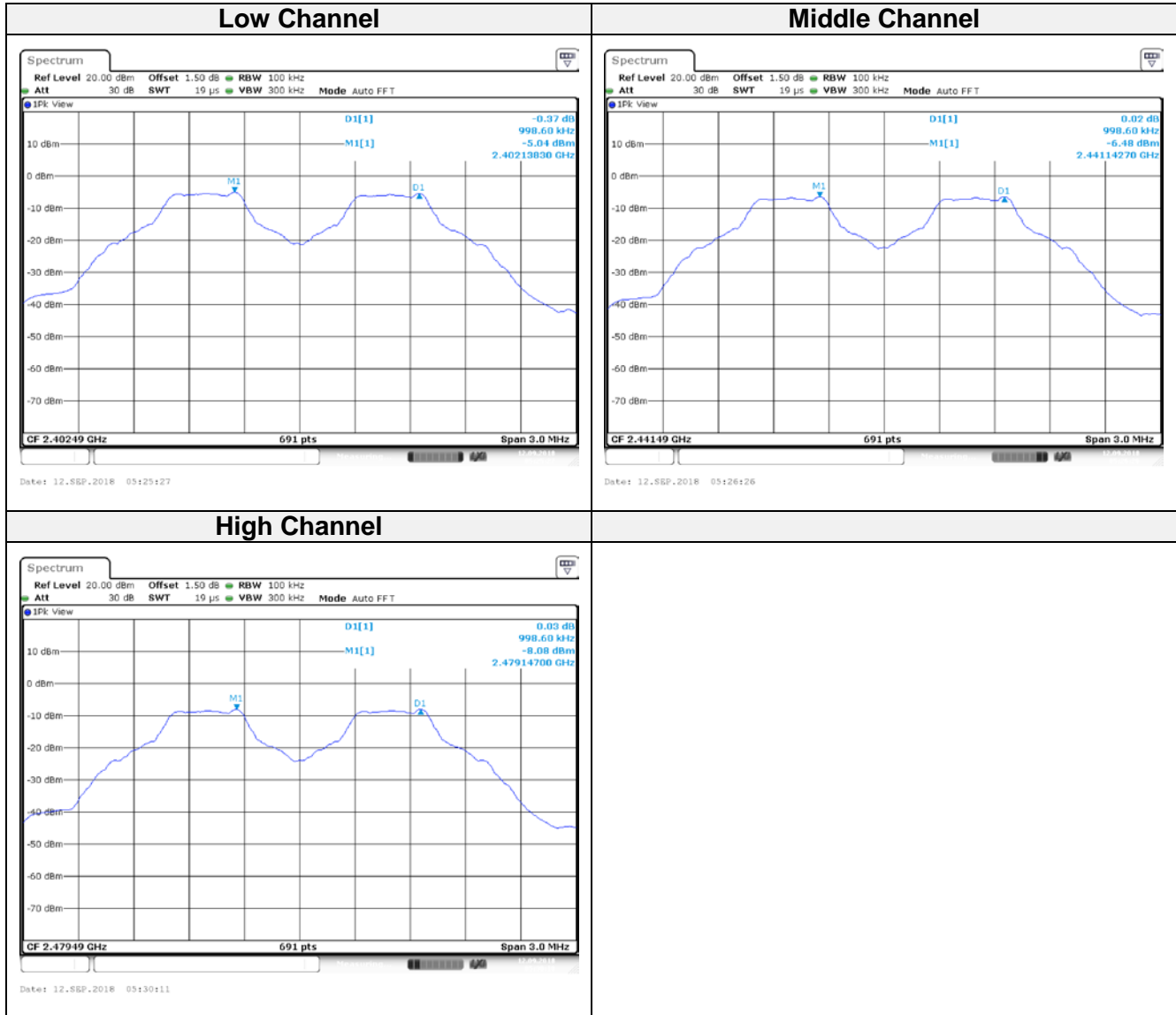

**EDR mode ( $\pi/4$ -DQPSK):**

**Low Channel**

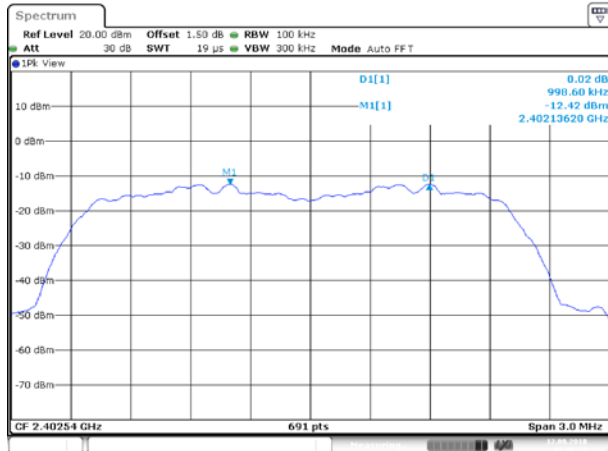

Date: 12.SEP.2010 05:48:37

**Middle Channel**

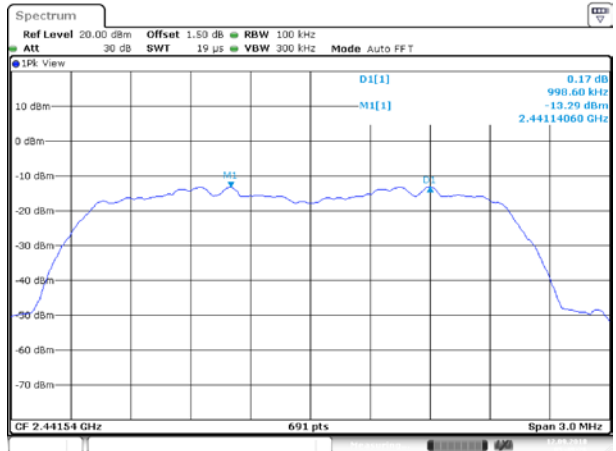

Date: 12.SEP.2010 05:49:26

**High Channel**

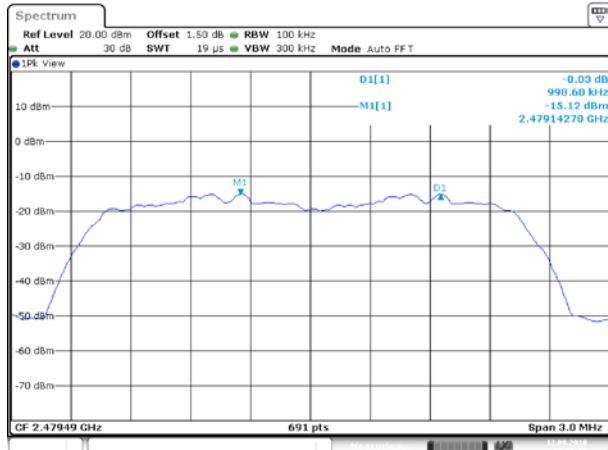

Date: 12.SEP.2010 05:56:20



**EDR mode (8-DPSK):**

**Low Channel**

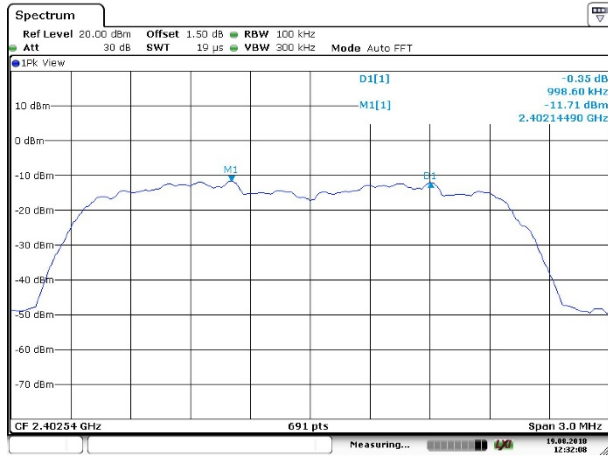

**Middle Channel**

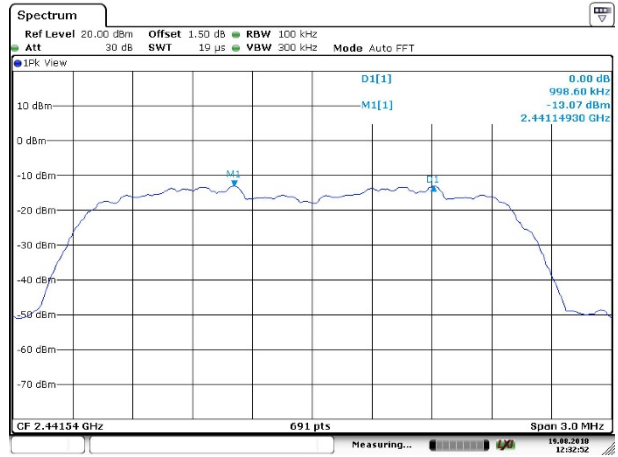

**High Channel**

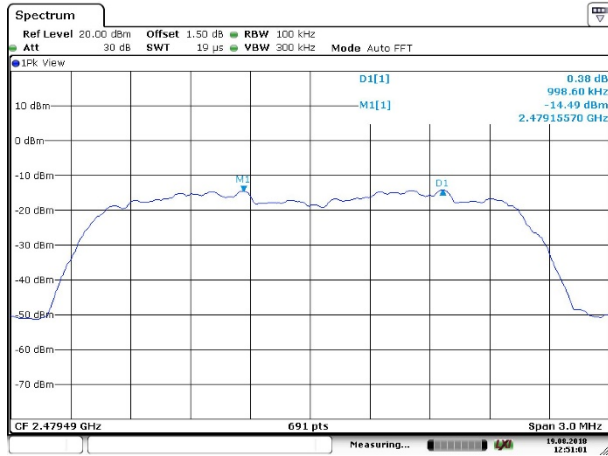

## 10 FCC §15.247(a)(1)(iii) – Time of Occupancy (Dwell Time)

### 10.1 Applicable Standard

According to FCC §15.247(a) (1)(iii).

Frequency hopping systems in the 2400–2483.5 MHz band shall use at least 15 channels. The average time of occupancy on any channel shall not be greater than 0.4 seconds within a period of 0.4 seconds multiplied by the number of hopping channels employed. Frequency hopping systems may avoid or suppress transmissions on a particular hopping frequency provided that a minimum of 15 channels are used.

### 10.2 Test Procedure

The EUT must have its hopping function enabled. Use the following spectrum analyzer settings: Span = zero span, centered on a hopping channel

RBW ≤ channel spacing and where possible RBW should be set  $\gg 1/T$ , where T is the expected dwell time per channel

Sweep = as necessary to capture the entire dwell time per hopping channel Detector function = peak

Trace = max hold

Use the marker-delta function to determine the transmit time per hop. If this value varies with different modes of operation (data rate, modulation format, number of hopping channels, etc.), then repeat this test for each variation in transmit time.

Repeat the measurement using a longer sweep time to determine the number of hops over the period specified in the requirements. The sweep time shall be equal to, or less than, the period specified in the requirements.

Determine the number of hops over the sweep time and calculate the total number of hops in the period specified in the requirements, using the following equation:

(Number of hops in the period specified in the requirements) = (number of hops on spectrum analyzer) x (period specified in the requirements / analyzer sweep time)

The average time of occupancy is calculated from the transmit time per hop multiplied by the number of hops in the period specified. If the number of hops in a specific time varies with different modes of operation (data rate, modulation format, number of hopping channels, etc.), then repeat this test for each variation.

### 10.3 Test Equipment List and Details

Descriptions	Manufacturers	Models	Serial Numbers	Calibration Date	Calibration Due Date
Spectrum Analyzer	Rohde & Schwarz	FSV40	101140	2017/11/15	2018/11/14
Cable	WOKEN	SFL402	S02-160323-07	2018/02/12	2019/02/11

**\*Statement of Traceability:** The testing equipment's listed above have finished the calibration by Electronics Testing Center, Taiwan (ETC) or other laboratories which were accredited by TAF or equivalent organizations. The calibration result could be traceable to the International System of Units (SI).

### 10.4 Test Environmental Conditions

Temperature:	25.2 °C
Relative Humidity:	54 %
ATM Pressure:	1015 hPa

The testing was performed by Eric Lee from 2018-08-19 to 2018-09-27.

### 10.5 Test Results

Time of Occupancy (Dwell Time) Result				
Modulation Mode	Pulse Time per Hop (ms)	Number of Pulse in	Dwell Time in	Dwell Time Limits (s)
		[0.4 x N sec]	[0.4 x N sec] (s)	
BR-1Mbps	2.95	106.7	0.315	0.4
EDR-2Mbps	2.95	106.7	0.315	0.4
EDR-3Mbps	2.95	106.7	0.315	0.4

\*Number of Pulse in [0.4 x N sec] = 1600/79/6\*(0.4\*79)

\*Dwell Time in [0.4 x N sec] = (Pulse Time \* Number of Pulse in [0.4 x N sec])/1000

\* Bluetooth ACL packets can be 1, 3, or 5 time slots. The DH1 packet can cover a single time slot. The DH3 packet can cover up to 3 time slots. The DH5 packet can cover up to 5 time slots. Operate DH5 at maximum dwell time and maximum duty cycle. A maximum length packet has duration of 5 time slots. The hopping rate is 1600 hops/second so the maximum dwell time is 5/1600 seconds, or 3.125ms.

Please refer to the following plots

DH5

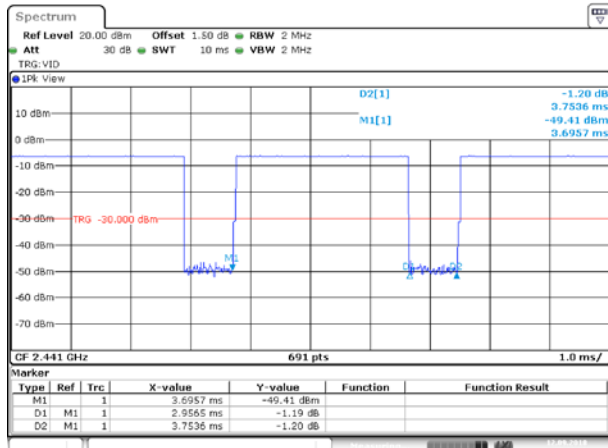

2DH5

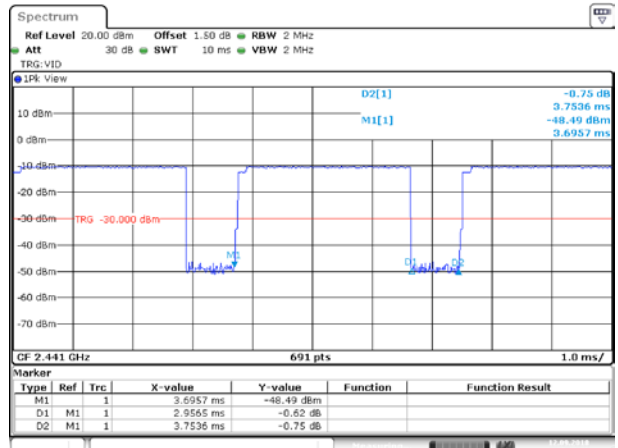

3DH5

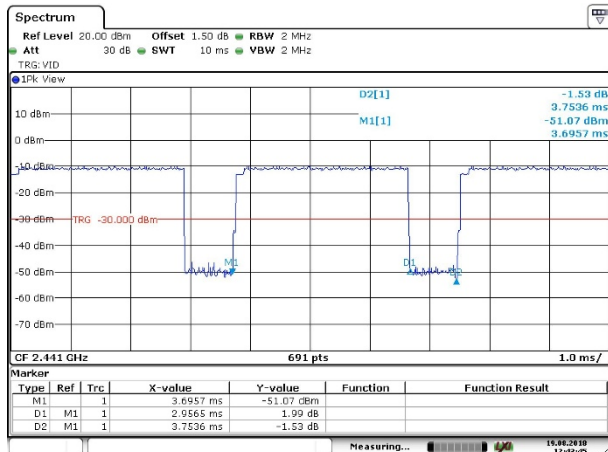

## 11 FCC §15.247(a)(1)(iii) –Quantity of hopping channel Test

### 11.1 Applicable Standard

According to FCC §15.247(a) (1) (iii).

Frequency hopping systems in the 2400-2483.5

MHz band shall use at least 15 channels. The average time of occupancy on any channel shall not be greater than 0.4 seconds within a period of 0.4 seconds multiplied by the number of hopping channels employed.

Frequency hopping systems may avoid or suppress transmissions on a particular hopping frequency provided that a minimum of 15 channels are used.

### 11.2 Test Procedure

Span = the frequency band of operation

RBW < 30% of the channel spacing or the 20 dB bandwidth, whichever is smaller VBW ≥ RBW

Sweep = auto

Detector function = peak Trace = max hold

### 11.3 Test Equipment List and Details

Descriptions	Manufacturers	Models	Serial Numbers	Calibration Date	Calibration Due Date
Spectrum Analyzer	Rohde & Schwarz	FSV40	101140	2017/11/15	2018/11/14
Cable	WOKEN	SFL402	S02-160323-07	2018/02/12	2019/02/11

*\*Statement of Traceability: The testing equipment's listed above have finished the calibration by Electronics Testing Center, Taiwan (ETC) or other laboratories which were accredited by TAF or equivalent organizations. The calibration result could be traceable to the International System of Units (SI).*

### 11.4 Test Environmental Conditions

Temperature:	25.2 °C
Relative Humidity:	54 %
ATM Pressure:	1015 hPa

The testing was performed by Eric Lee from 2018-08-19 to 2018-09-27.

### 11.5 Test Results

Mode	Frequency Range (MHz)	Number of Hopping Channel	Limit (CH)	Result
GFSK	2402-2480	79	>15	Compliance
$\pi/4$ -DQPSK	2402-2480	79	>15	Compliance
8DPSK	2402-2480	79	>15	Compliance

Please refer to the following plots

**BR mode (GFSK)**

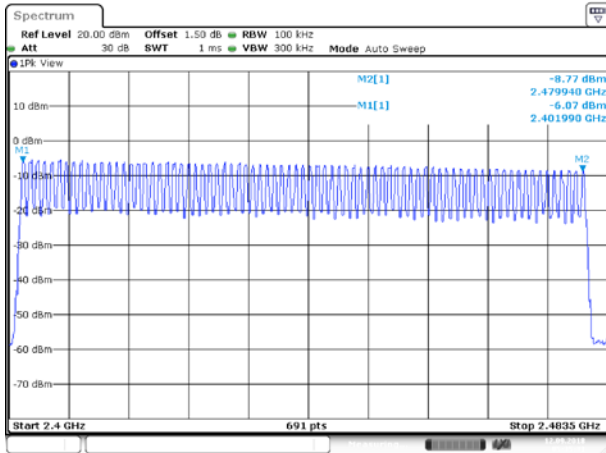

**EDR mode ( $\pi/4$ -DQPSK)**

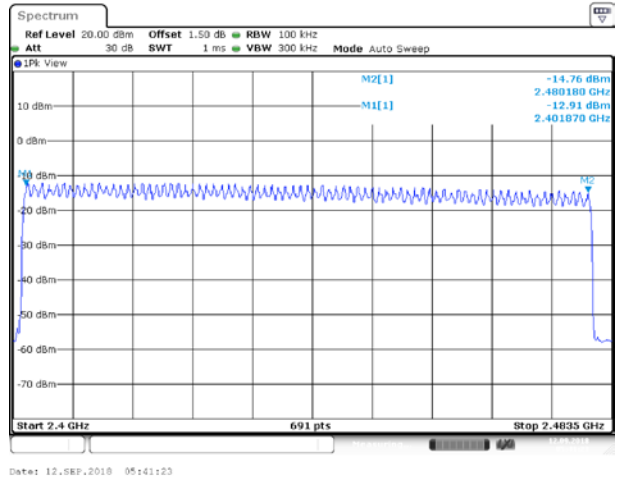

**EDR mode (8DPSK)**

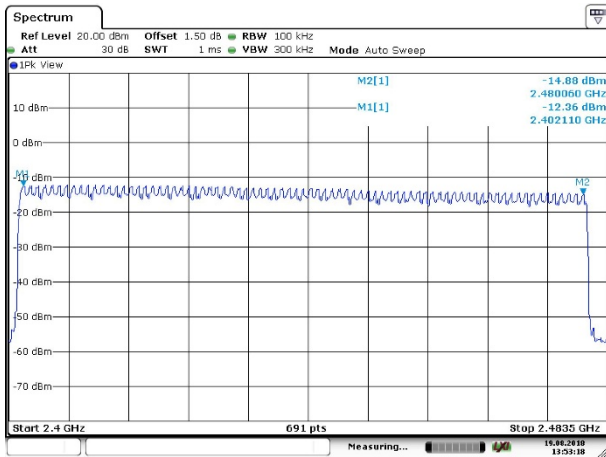

## 12 FCC §15.247(b)(1) – Maximum Output Power

### 12.1 Applicable Standard

According to FCC §15.247(b) (1): For frequency hopping systems operating in the 2400-2483.5 MHz band employing at least 75 non-overlapping hopping channels, and all frequency hopping systems in the 5725-5850 MHz band: 1 watt. For all other frequency hopping systems in the 2400-2483.5 MHz band: 0.125 watts.

### 12.2 Test Procedure

Place the EUT on a bench and set it in transmitting mode.  
Remove the antenna from the EUT and then connect a low loss RF cable from the antenna port to an Power sensor.

### 12.3 Test Equipment List and Details

Descriptions	Manufacturers	Models	Serial Numbers	Calibration Date	Calibration Due Date
Power Sensor	KEYSIGHT	U2021XA	MY54080018	2018/03/07	2019/03/06
Cable	WOKEN	SFL402	S02-160323-07	2018/02/12	2019/02/11

**\*Statement of Traceability:** The testing equipment's listed above have finished the calibration by Electronics Testing Center, Taiwan (ETC) or other laboratories which were accredited by TAF or equivalent organizations. The calibration result could be traceable to the International System of Units (SI).

### 12.4 Test Environmental Conditions

Temperature:	25.2 °C
Relative Humidity:	54 %
ATM Pressure:	1015 hPa

The testing was performed by Eric Lee from 2018-08-19 to 2018-09-27.

**12.5 Test Results**

Channel	Frequency (MHz)	Maximum peak Conducted Output Power (dBm)	Limit (dBm)	Result
<b>BR mode (GFSK)</b>				
Low	2402	-4.41	21	Compliance
Middle	2441	-5.97	21	Compliance
High	2480	-7.6	21	Compliance
<b>EDR mode (<math>\pi/4</math>-DQPSK)</b>				
Low	2402	-8.42	21	Compliance
Middle	2441	-9.25	21	Compliance
High	2480	-11.07	21	Compliance
<b>EDR mode (8DPSK)</b>				
Low	2402	-8.21	21	Compliance
Middle	2441	-9.17	21	Compliance
High	2480	-10.88	21	Compliance



## 13 FCC §15.247(d) – 100 kHz Bandwidth of Frequency Band Edge

### 13.1 Applicable Standard

According to FCC §15.247(d), in any 100 kHz bandwidth outside the frequency bands in which the spread spectrum intentional radiator is operating, the radio frequency power that is produced by the intentional radiator shall be at least 20 dB below that in the 100 kHz bandwidth within the band that contains the highest level of the desired power, based on either an RF conducted or a radiated measurement. In addition, radiated emissions which fall in the restricted bands, as defined in §15.205(a), must also comply with the radiated emissions limits specified in §15.209(a) see §15.205(c)

### 13.2 Test Procedure

Span = wide enough to capture the peak level of the emission operating on the channel closest to the band edge, as well as any modulation products which fall outside of the authorized band of operation

RBW = 100 kHz VBW = 300 kHz

Sweep = coupled

Detector function = peak Trace = max hold

### 13.3 Test Equipment List and Details

Descriptions	Manufacturers	Models	Serial Numbers	Calibration Date	Calibration Due Date
Spectrum Analyzer	Rohde & Schwarz	FSV40	101140	2017/11/15	2018/11/14
Cable	WOKEN	SFL402	S02-160323-07	2018/02/12	2019/02/11

**\*Statement of Traceability:** The testing equipment's listed above have finished the calibration by Electronics Testing Center, Taiwan (ETC) or other laboratories which were accredited by TAF or equivalent organizations. The calibration result could be traceable to the International System of Units (SI).

### 13.4 Test Environmental Conditions

Temperature:	25.2 °C
Relative Humidity:	54 %
ATM Pressure:	1015 hPa

The testing was performed by Eric Lee from 2018-08-19 to 2018-09-27.

### 13.5 Test Results

Channel	Frequency (MHz)	Delta Peak to Band Emission (dBc)	Limit (dBc)	Result
<b>BR mode (GFSK)</b>				
Low	2402	51.97	≥ 20	Compliance
High	2480	49.10	≥ 20	Compliance
<b>BR Hopping mode (GFSK)</b>				
Low	2402	51.24	≥ 20	Compliance
High	2480	48.72	≥ 20	Compliance
<b>EDR mode (<math>\pi</math>/4-DQPSK)</b>				
Low	2402	44.81	≥ 20	Compliance
High	2480	42.07	≥ 20	Compliance
<b>EDR Hopping mode (<math>\pi</math>/4-DQPSK)</b>				
Low	2402	43.96	≥ 20	Compliance
High	2480	42.53	≥ 20	Compliance
<b>EDR mode (8DPSK)</b>				
Low	2402	46.33	≥ 20	Compliance
High	2480	43.68	≥ 20	Compliance
<b>EDR Hopping mode (8DPSK)</b>				
Low	2402	43.83	≥ 20	Compliance
High	2480	43.28	≥ 20	Compliance

Please refer to the following plots

**BR mode (GFSK):**

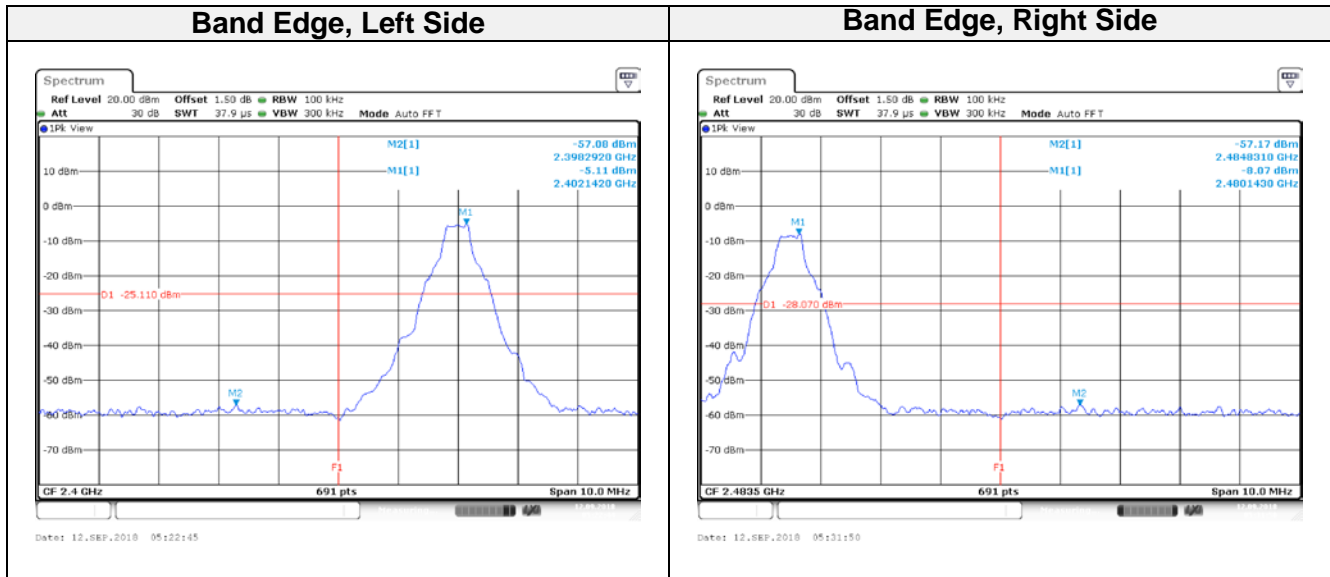

**BR Hopping mode (GFSK):**

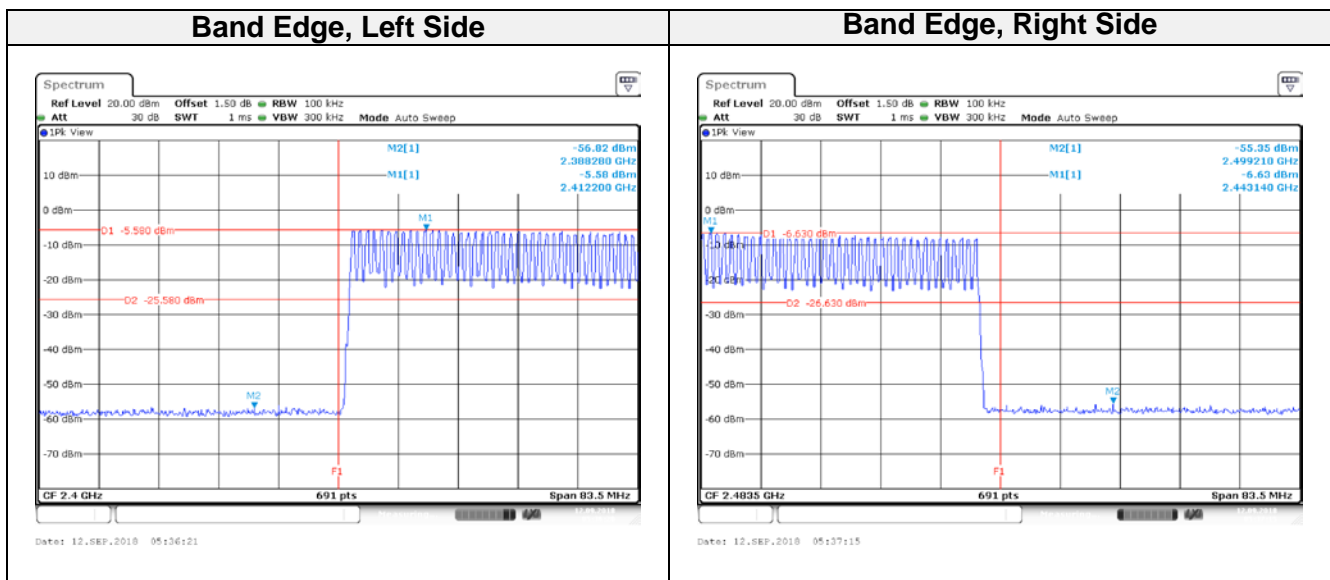

**EDR mode ( $\pi/4$ -DQPSK):**

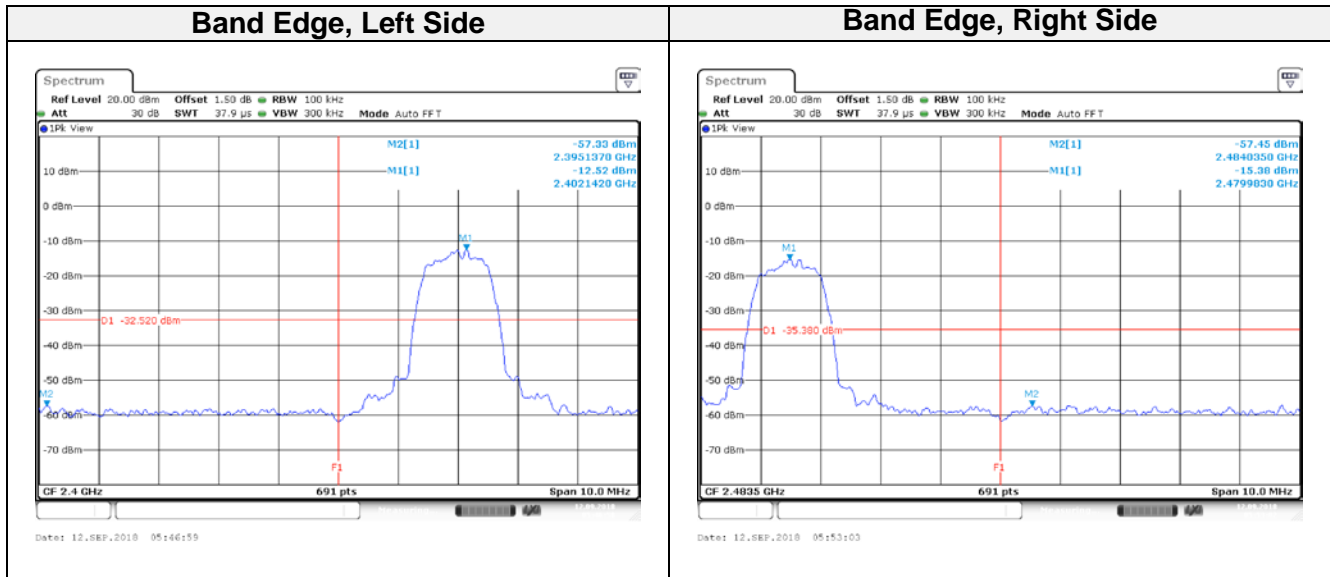

**EDR Hopping mode ( $\pi/4$ -DQPSK):**

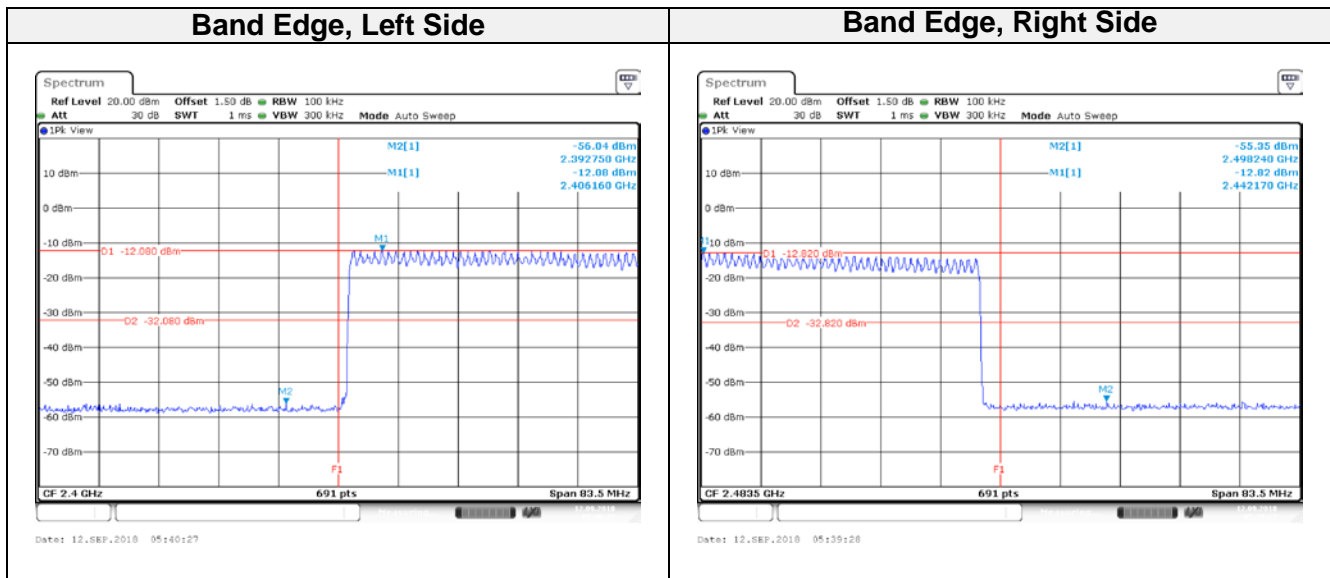

**EDR mode (8DPSK):**

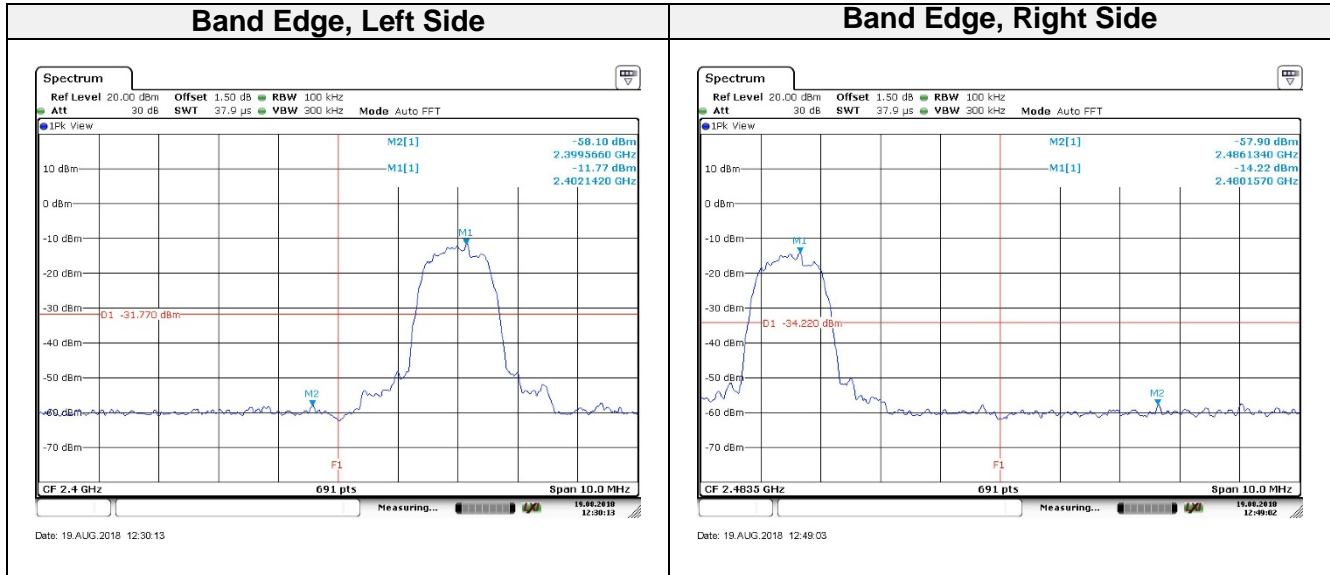

**EDR Hopping mode (8DQSK):**

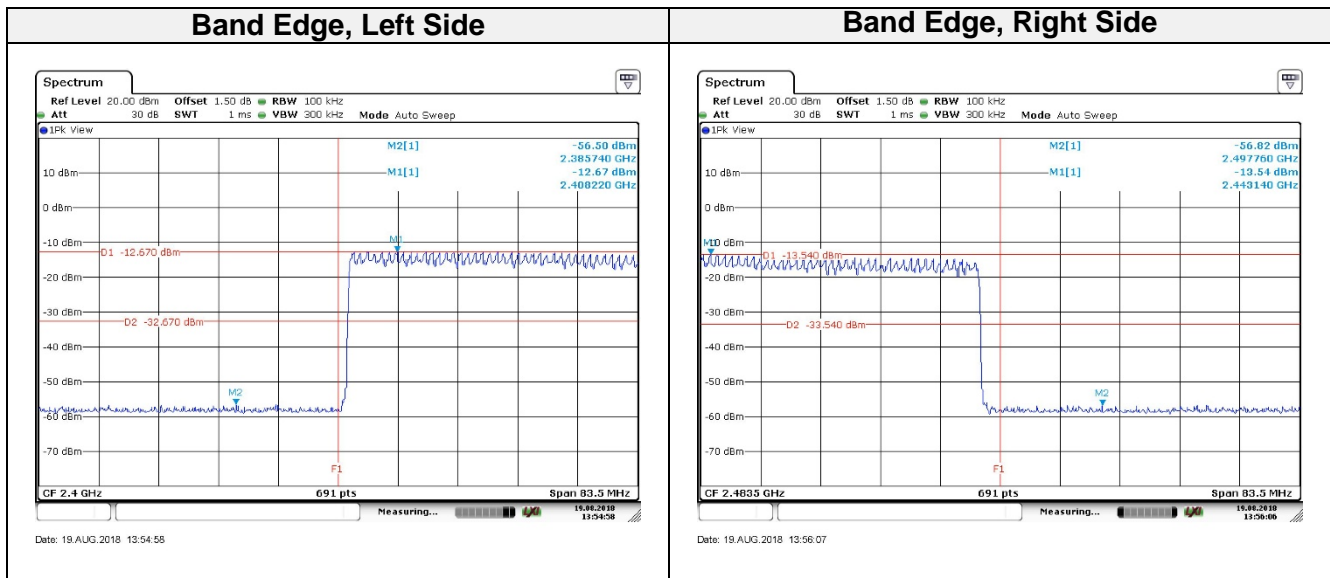

----- END OF REPORT -----