



# TEST REPORT

**Report No. :** HST201604-1301-FCC

**Product description:** Wireless Microphone

**Model/Type :** M-600, M-601, M-602, M-603, M-604, M-605, M-606, M-607, M-608

**Applicant's name:** GUANG ZHOU PANYU MINFU  
SPEAKER FACTORY



**TEST REPORT**  
**FCC Part 74.861e: 2015**  
**FCCID: OGGM-600**

**Report Reference No.** .....: HST201604-1301-FCC

**Tested by (+ signature)** .....: *Lemon Fu* Lemon Fu

**Review by (+ signature)** .....: *Sandy Yu* Sandy Yu

**Approved by (+ signature)**.....: *Robin Peng* Robin Peng

**Date of Sample Receive** .....: Apr. 1, 2016

**Date of Test**.....: Apr. 1, 2016 to Apr. 8, 2016

**Date of issue** .....: Apr. 9, 2016

**Total number of pages** .....: 26 Pages

**Testing Laboratory**.....: Guangdong Environment Radiation Monitoring Center  
(Accredited by CNAS, Accredited Number: L5539)  
FCC- Registration No: 667318 Renewal on Sep. 12, 2012  
**Address** .....: No. 860, South Guangzhou Avenue, Guangzhou, 510300 China

**Applicant's name** .....: GUANG ZHOU PANYU MINFU SPEAKER FACTORY  
**Address** .....: DONG SHENG SAN HENG RD., CHADONG, SHIJI, PANYU DIS  
GUANGZHOU, China

**Manufacturer's name** .....: GUANG ZHOU PANYU MINFU SPEAKER FACTORY  
**Address** .....: DONG SHENG SAN HENG RD., CHADONG, SHIJI, PANYU DIS  
GUANGZHOU, China

**Test specification**.....: Entrusted testing  
**Standard**.....: FCC Part 74.861e: 2015  
**Non-standard test method**.....: N/A

**Test item description** .....: Wireless Microphone  
**Trade Mark** .....: N/A  
**Model/Type reference** .....: M-600  
**Ratings** .....: 3.0Vdc 2\*AA Batteries

## TABLE OF CONTENT

	TEST REPORT .....	1
1	Test Summary .....	4
2	General Information.....	5
	2.1 Client Information .....	5
	2.2 General Description of E.U.T. ....	5
	2.3 Details of E.U.T. ....	5
	2.4 Description of Support Units.....	5
	2.5 Standards Applicable for Testing .....	5
	2.6 Test Location .....	6
	2.7 Deviation from Standards.....	6
	2.8 Abnormalities from Standard Conditions.....	6
3	Test Results .....	7
	3.1 E.U.T. Operation Condition .....	7
	3.2 Test Procedure & Measurement Data.....	8
	3.2.1 Carrier Radiated Power & Radiated Spurious Emissions.....	8
	3.2.2 Occupied Bandwidth .....	11
	3.2.3 Frequency Stability.....	14
	3.2.4 Modulation Characteristics.....	16
	3.3 Photographs .....	19
	3.3.1 Radiated Emission Test Setup.....	19
	3.3.2 EUT Constructional Details .....	20
	3.3.3 Antenna Photo .....	25
4	Equipments Used during Test.....	26

## 1 TEST SUMMARY

Test	Test Requirement	Standard Paragraph	Result
Carrier Radiated Power	FCC Part 2.1046	74.861 e) 1) 54–72, 76–88 & 174–216 MHz bands, 50 mW 470–608 and 614–806 MHz bands, 250 mW	PASS
Modulation Deviation	FCC Part 2.1047	74.861 e) 3) Within 75kHz	PASS
Frequency Stability	FCC Part 2.1055	74.861 e) 4) <0.005% 50 ppm	PASS
Operating Bandwidth	FCC Part 2.1049 c)	74.861 e) 5) Within 200kHz	PASS
Unwanted Radiation	FCC Part 2.1049 c)	74.861 e) 6) within the mask	PASS
Radiated Spurious Emission	FCC Part 2.1053	74.861 d) 3) < 43+10lgP(W) dB	PASS

Remark:

♣The EUT has one channel, which is located in the range 174.200 MHz to 215.800MHz.

Only test result of sample of in channels 174.2 MHz, 202.748 MHz and 215.8 MHz were recorded in this report.

Model: M-600, M-601, M-602, M-603, M-604, M-605, M-606, M-607, M-608

Only tested M-600, since the other models listed above are electric identical with only difference being the model name.

## 2 GENERAL INFORMATION

### 2.1 Client Information

Applicant: GUANG ZHOU PANYU MINFU SPEAKER FACTORY  
Address of Applicant: DONG SHENG SAN HENG RD., CHADONG, SHIJI, PANYU DIS  
GUANGZHOU, China

### 2.2 General Description of E.U.T.

EUT Name: Wireless Microphone  
Item No.: Listed on the 3<sup>rd</sup> page  
Serial No.: Not supplied by client

### 2.3 Details of E.U.T.

Power Supply: 3.0Vdc 2\*AA Batteries  
Main Function: Wireless microphone system with an associated receiver for  
transmitting voice.

The final amplifier Collector Voltage and Collector Current are 0.13V & 3.5mA respectively.

Necessary Bandwidth:  $2M+2DK= 2 \times 80 \text{ kHz} + 2 \times 20\text{kHz} \times 1.0 = 200 \text{ kHz}$

1 channel for each microphone; Modulation: F3E; Antenna Type: Fixed; Gained: 0 dBi

### 2.4 Description of Support Units

Connect the EUT to mains power, and then test the EUT with signal generator.

### 2.5 Standards Applicable for Testing

The standard used was FCC Part 74.861e: 2015

The EUT belongs to licensed low power auxiliary devices.

## 2.6 Test Location

Guangdong Environment Radiation Monitoring Center

Address: No. 860, South Guangzhou Avenue, Guangzhou, 510300 China

Accredited by CNAS, Accredited Number: L5539

FCC- Registration No: 667318 Renewal on Sep. 12, 2012

## 2.7 Deviation from Standards

None.

## 2.8 Abnormalities from Standard Conditions

None.

### 3 TEST RESULTS

#### 3.1 E.U.T. Operation Condition

Operating Environment:

Temperature: 20.0 °C~25 °C

Humidity: 50 ~70% RH

Atmospheric Pressure: 980~1012 mbar

EUT Operation: Test the EUT in transmitting mode.

Performed Carrier Radiated Power & Radiated Spurious Emissions testing in highest/ middle / lowest frequency spots within the range, and performed Occupied Bandwidth, Frequency Stability & Modulation Characteristics in middle frequency spot.

## 3.2 Test Procedure & Measurement Data

### 3.2.1 Carrier Radiated Power & Radiated Spurious Emissions

Test Requirement: FCC CFR 47 Part 74.861 e) 1) & d) 3)

Test Method: EIA/TIA 603-D:2010 section 2.2,  
FCC CFR 47 Part 2.1047 & 1053

Test Date: Apr. 5, 2016

Measurement Distance: 3m (Semi-Anechoic Chamber)

Test Requirement:

(d) For low power auxiliary stations operating in the bands other than those allocated for TV broadcasting, the following technical requirements are imposed.

(3) The occupied bandwidth shall not be greater than that necessary for satisfactory transmission and, in any event, an emission appearing on any discrete frequency outside the authorized band shall be attenuated, at least,  $43+10 \log^{10}$  (mean output power, in watts) dB below the mean output power of the transmitting unit.

(e) For low power auxiliary stations operating in the bands allocated for TV broadcasting, the following technical requirements apply:

(1) The power of the measured unmodulated carrier power at the output of the transmitter power amplifier (antenna input power) may not exceed the following:

(i) 54–72, 76–88, and 174–216 MHz bands—50 mW

(ii) 470–608 and 614–806 MHz bands—250 mW

Test Procedure:

The procedure used was EIA/TIA 603-D:2010. The receiver was scanned from the lowest radio frequency generated in the equipment to the tenth harmonic of the carrier. When an emission was found, the table was rotated to produce the maximum signal strength. An initial pre-scan was performed for in peak detection mode using the receiver. The EUT was measured for both the Horizontal and Vertical polarities and performed a pre-test three orthogonal planes.

The field strength is calculated by adding the Antenna Factor, Cable Factor & Preamplifier. The basic equation with a sample calculation is as follows:

Final Test Level = Receiver Reading + Antenna Factor + Cable Factor – Preamplifier Factor

An initial pre-scan was performed in the 3m chamber using the spectrum analyzer in peak detection mode. Quasi-peak measurements were conducted based on the peak sweep graph. The EUT was measured by Bilog antenna with 2 orthogonal polarities

Remove the EUT and replace it with substitution antenna. A signal generator was connected to the substitution antenna by a non-radiating cable. The absolute levels of the Carrier Radiated Power and spurious emissions were measured by the substitution.



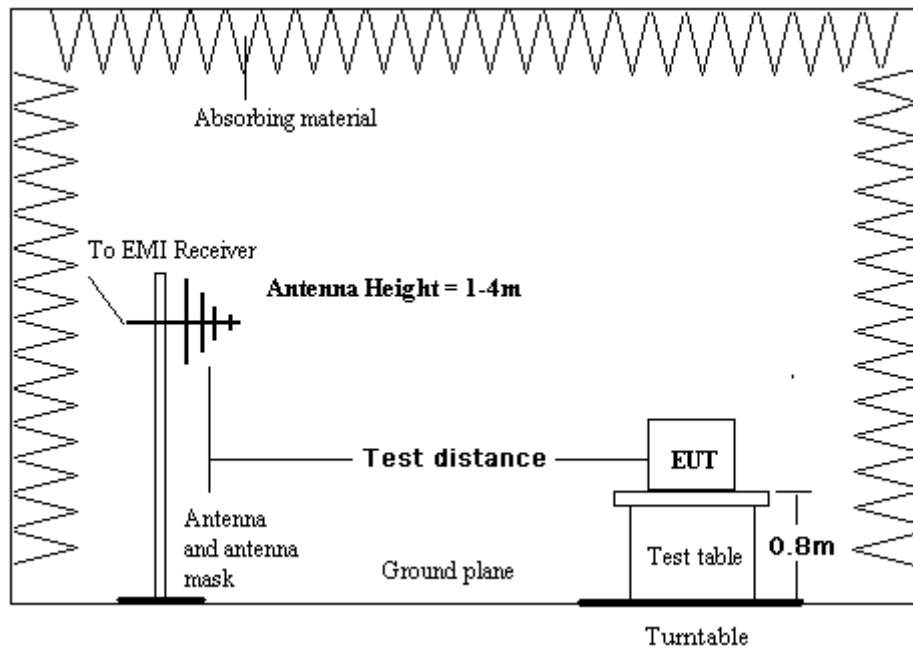

Conducted output power:

Remove the antenna from the EUT and then connect a low attenuation RF cable from the antenna port to the spectrum.

Set the spectrum analyzer: RBW = 300 kHz. VBW >= RBW. Span=2MHz, Sweep = auto; Detector Function = Peak (Max. hold).

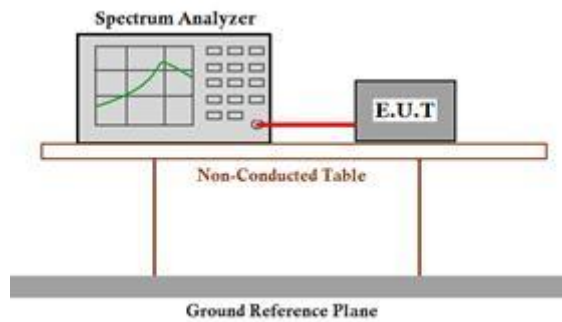

**Test Result:**

Carrier Frequency (MHz)	Factual Level dBm (mW)	conducted output power dBm (mW)	Limit in 74.861 e) 1)
174.200	-2.8dBm(i.e.0.52 mW)	-2.9dBm(i.e.0.51 mW)	17 dBm (i.e. 50 mW)
202.748	-3.0dBm(i.e.0.50 mW)	-3.1dBm(i.e.0.49 mW)	17 dBm (i.e. 50 mW)
215.800	-3.0dBm(i.e. 0.50 mW)	-3.1dBm(i.e. 0.49 mW)	17 dBm (i.e. 50 mW)

**The Factual Level is ERP value.**

**Radiated spurious emissions:**

174.200 MHz					
Spurious Emission Frequency (MHz)	Horizontal		Vertical		Limit (dBm)
	Factual Level (dBm)	Margin(dB)	Factual Level (dBm)	Margin(dB)	
87.100	<-43	NA	<-43	NA	-13
348.400	<-43	NA	<-43	NA	-13
522.600	<-43	NA	<-43	NA	-13
696.800	<-43	NA	<-43	NA	-13
871.000	<-43	NA	<-43	NA	-13
1045.200	<-43	NA	<-43	NA	-13
1219.400	<-43	NA	<-43	NA	-13
1393.600	<-43	NA	<-43	NA	-13
1567.800	<-43	NA	<-43	NA	-13
1742.000	<-43	NA	<-43	NA	-13
202.748 MHz					
101.374	<-43	NA	<-43	NA	-13
405.496	<-43	NA	<-43	NA	-13
608.244	<-43	NA	<-43	NA	-13
810.992	<-43	NA	<-43	NA	-13
1013.740	<-43	NA	<-43	NA	-13
1216.488	<-43	NA	<-43	NA	-13
1419.236	<-43	NA	<-43	NA	-13
1621.984	<-43	NA	<-43	NA	-13
1824.732	<-43	NA	<-43	NA	-13
2027.480	<-43	NA	<-43	NA	-13
215.800 MHz					
107.900	<-43	NA	<-43	NA	-13
431.600	<-43	NA	<-43	NA	-13
647.400	<-43	NA	<-43	NA	-13
863.200	<-43	NA	<-43	NA	-13
1079.000	<-43	NA	<-43	NA	-13
1294.800	<-43	NA	<-43	NA	-13
1510.600	<-43	NA	<-43	NA	-13
1726.400	<-43	NA	<-43	NA	-13
1942.200	<-43	NA	<-43	NA	-13
2158.000	<-43	NA	<-43	NA	-13

**The Factual Level is ERP value.**

The peak emission of other frequency in rang from 30MHz up to 10 times carrier were 25dB lower than the limit, hence no data was recorded in the report.

NA: Not applicable, since the level is over 30dB lower than the limit.

**TEST RESULTS: The unit does meet the FCC requirements.**

### 3.2.2 Occupied Bandwidth

Test Requirement: FCC CFR 47 Part 74.e) 5) & 6)

Test Method: FCC CFR 47 Part 2.1049 f) 2 )

Test Date: Apr. 8, 2016

Requirements:

(e) For low power auxiliary stations operating in the bands allocated for TV broadcasting, the following technical requirements apply:

(5) The operating bandwidth shall not exceed 200 kHz.

(6) The mean power of emissions shall be attenuated below the mean output power of the transmitter in accordance with the following schedule:

(i) On any frequency removed from the operating frequency by more than 50 percent up to and including 100 percent of the authorized bandwidth: at least 25dB;

(ii) On any frequency removed from the operating frequency by more than 100 percent up to and including 250 percent of the authorized bandwidth: at least 35dB;

(iii) On any frequency removed from the operating frequency by more than 250 percent of the authorized bandwidth: at least  $43 + 10 \log_{10}$  (mean output power in watts) dB.

#### Test Procedure

Setup

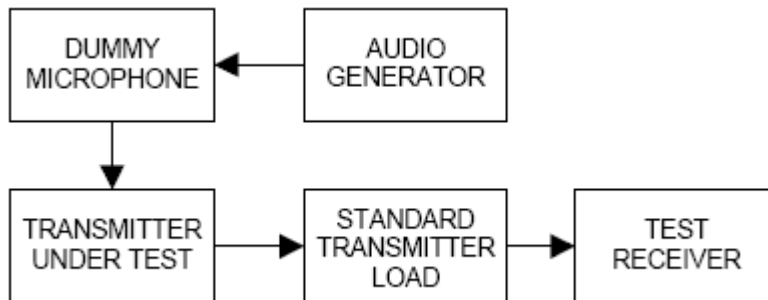

Input 2500Hz signal to the microphone, find the 50% rated deviation, add the level 16dB, test this status the 99% occupied bandwidth and record it.

Test Result: The graph as below, represents the emissions take for this device.

Occupied Bandwidth ( 99% of total power): 102.0 kHz.

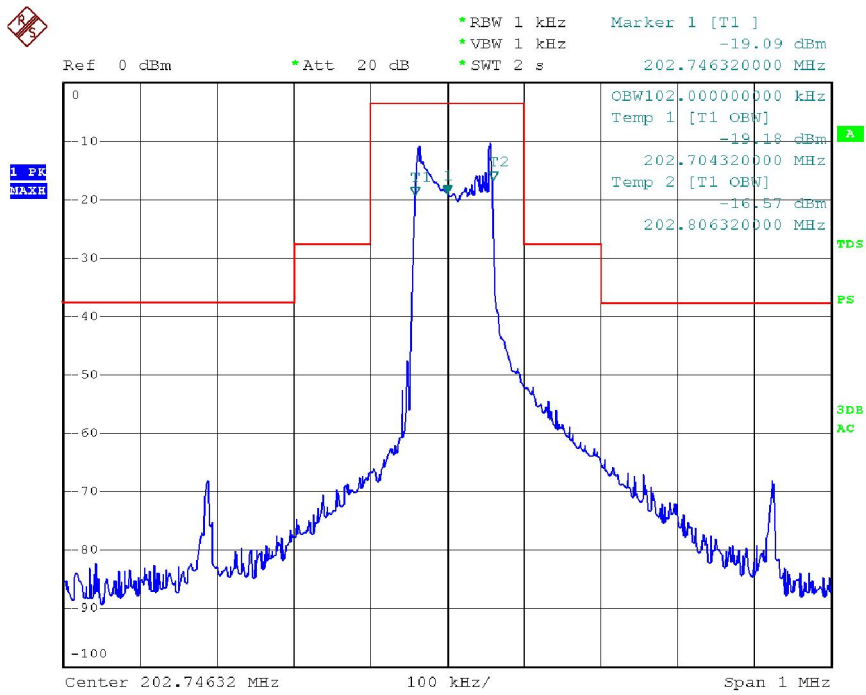

Date: 8.APR.2016 06:21:15

Emission Mask: input with 10 kHz AF, 50% modulation + 16dB.

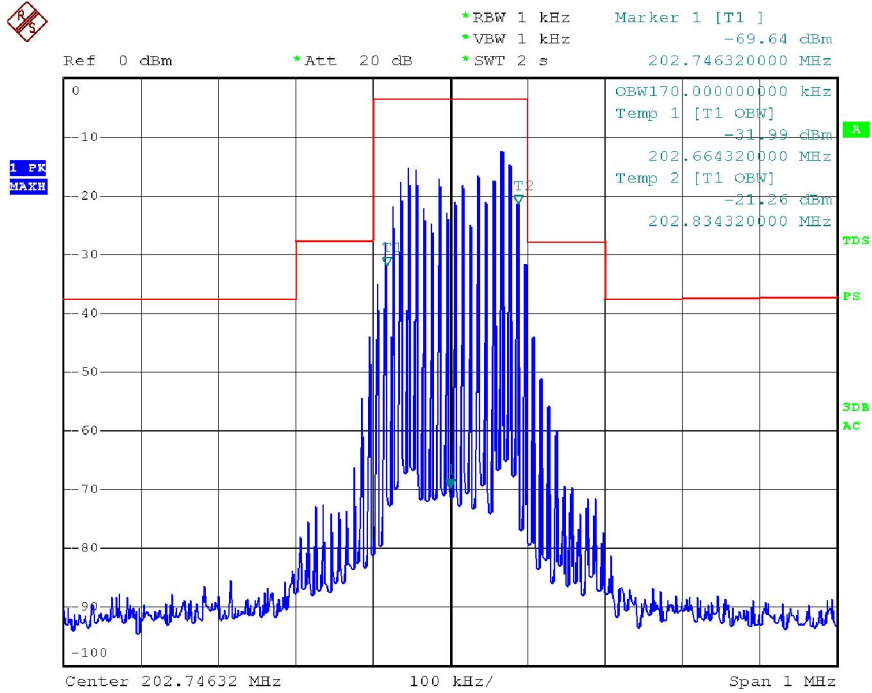

Date: 8.APR.2016 06:19:40

Emission Mask: input with 15 kHz AF, 50% modulation + 16dB.

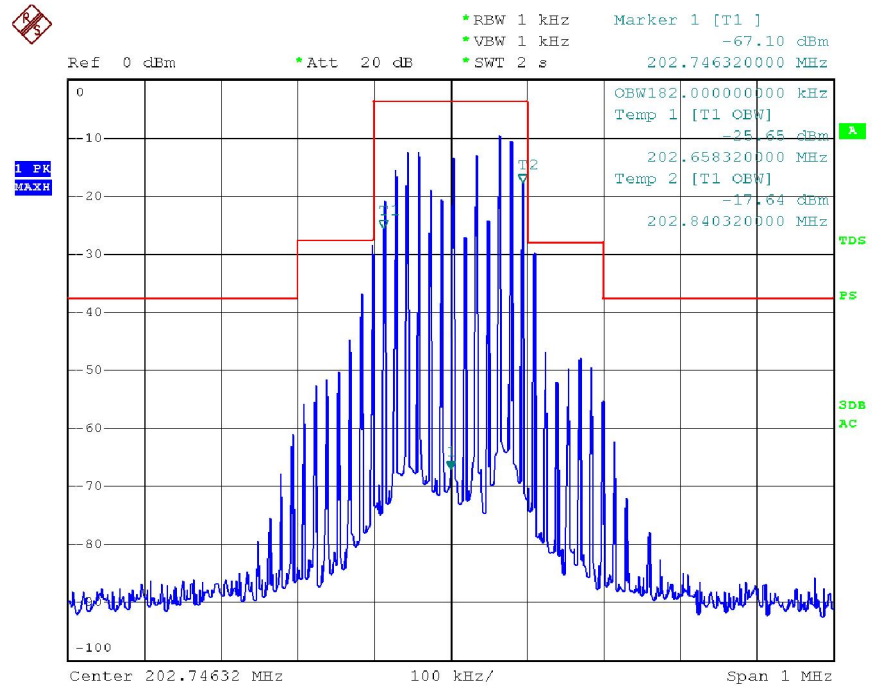

Date: 8.APR.2016 06:19:00

**Test results: The unit does meet the FCC requirements.**

### 3.2.3 Frequency Stability

Test Requirement: FCC CFR 47 Part 74.e) 4)

Test Method: FCC CFR 47 Part 2.1055

Test Date: Apr. 7, 2016

Requirements: +/-50 ppm

(e) For low power auxiliary stations operating in the bands allocated for TV broadcasting, the following technical requirements apply:

(4) The frequency tolerance of the transmitter shall be 0.005 percent.

#### Test Procedure:

##### Frequency stability versus Environmental Temperature

The equipment under test was connected to an external DC power supply and the RF output was connected to a frequency counter via feed through attenuators. The EUT was placed inside the temperature chamber. After the temperature stabilized for approximately 20 minutes, the frequency of the output signal was recorded from the counter.

##### Frequency Stability versus Input Voltage

At room temperature ( $25 \pm 5^{\circ}\text{C}$ ), an external variable DC power supply was connected to the EUT. The frequency of the transmitter was measured for 115%, 100% and 85% of the nominal operating input voltage. For hand carried, battery powered equipment, reduce primary supply voltage to the battery operating end point which shall be specified by the manufacturer.

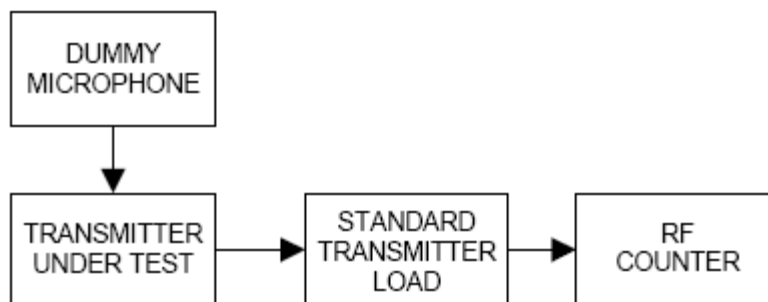

**Test Result:**

Assigned Frequency: 174.2 MHz/ 202.748 MHz/ 215.8 MHz				
Environment Temperature (°C)	Power Supplied (Vdc)	Frequency Measure with Time Elapsed Total emission within		
		+/-8.71kHz	+/-10.14kHz	+/-10.79kHz
50	3.0	-2.7	-2.3	-3.2
40	3.0	3.2	2.4	2.7
30	3.0	3.3	2.9	2.8
20	3.0	-2.4	-2.8	-2.3
10	3.0	-2.3	-1.7	-2.2
0	3.0	5.5	4.5	6.3
-10	3.0	-2.2	-2.7	-2.2
-20	3.0	-6.2	-5.2	-5.2
-30	3.0	-5.4	-6.1	-6.4
Environment Temperature (°C)	Power Supplied (Vdc)	Frequency Measure with Time Elapsed Total emission within		
		+/-8.71kHz	+/-10.14kHz	+/-10.79kHz
25	3.0	-6.2	-5.2	-2.2
25	2.8	0.4	0.2	0.3
25	2.6	0.5	0.5	1.0
25	2.4	-1.7	-1.9	-1.9

The EUT end point: 2.4Vdc

**The results: The unit does meet the FCC requirements.**

### 3.2.4 Modulation Characteristics

Test Requirement: FCC CFR 47 Part 74.e) 3)

Test Method: FCC CFR 47 Part 2.1047

Test Date: Apr. 6, 2016

Requirements:

(e) For low power auxiliary stations operating in the bands allocated for TV broadcasting, the following technical requirements apply:

(3) Any form of modulation may be used. A maximum deviation of  $\pm 75$  kHz is permitted when frequency modulation is employed.

Test Procedure:

#### Audio Frequency Response

The RF output of the transceiver was connected to the input of FSP 30 with FM deviation module through sufficient attenuation so as not to overload the meter or distort the reading. An audio signal generator was connected to the audio input of microphone.

The audio signal input level was adjusted to obtain **20% of the maximum rated system deviation at 1 kHz**, and recorded as  $DEV_{REF}$ . With the audio signal generator level unchanged, set the generator frequency between 100 to 5000 Hz. The transmitter deviations ( $DEV_{FREQ}$ ) were measured and the audio frequency response was calculated as  $20\log_{10} [DEV_{FREQ} / DEV_{REF}]$

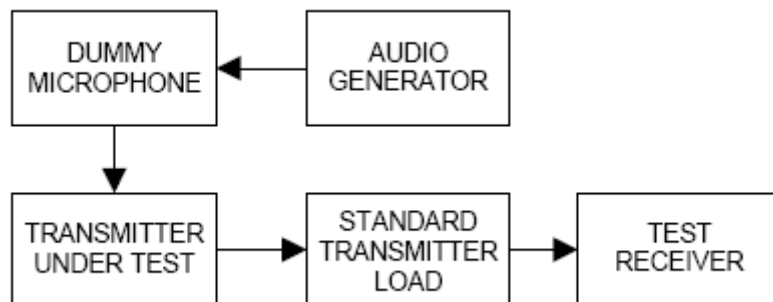



The plot(s) of Audio Frequency Response is presented hereinafter as reference.

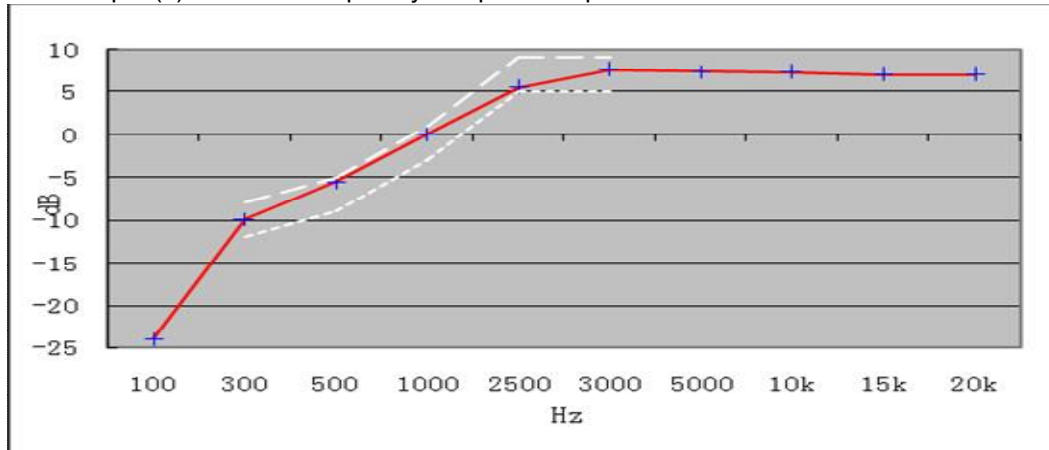

0dB=10mV at 1kHz (20% of the maximum rated system deviation).

#### Modulation Limiting

- Adjust the transmitter per the manufacturer's procedure for full rated system deviation.
- Set the test receiver to measure peak positive deviation. Set the audio bandwidth for  $\leq 0.25$  Hz to  $\geq 15,000$  Hz. Turn the de-emphasis function off.
- Apply a **1000 Hz** modulating signal to the transmitter from the audio frequency generator, and adjust the level to obtain **60% of full rated system deviation**.
- Increase the level from the audio frequency generator by 20 dB in one step (rise time between the 10% and 90% points shall be 0.1 second maximum).
- Measure both the instantaneous and steady-state deviation at and after the time of increasing the audio input level.
- With the level from the audio frequency generator held constant at the level obtained in step e), slowly vary the audio frequency from 100 to 5000 Hz and observe the steady-state deviation. Record the maximum deviation.

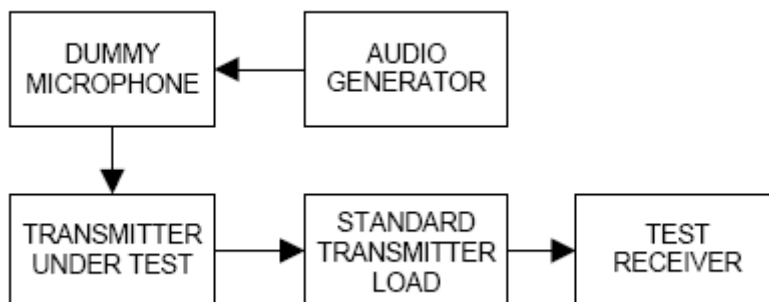

Test at five different modulating frequencies (100Hz ,300Hz, 500Hz, 1KHz, 2.5kHz, 5kHz), the output level of the audio generator was varied up to 1V and the FM deviation level was recorded.

Positive peak deviation

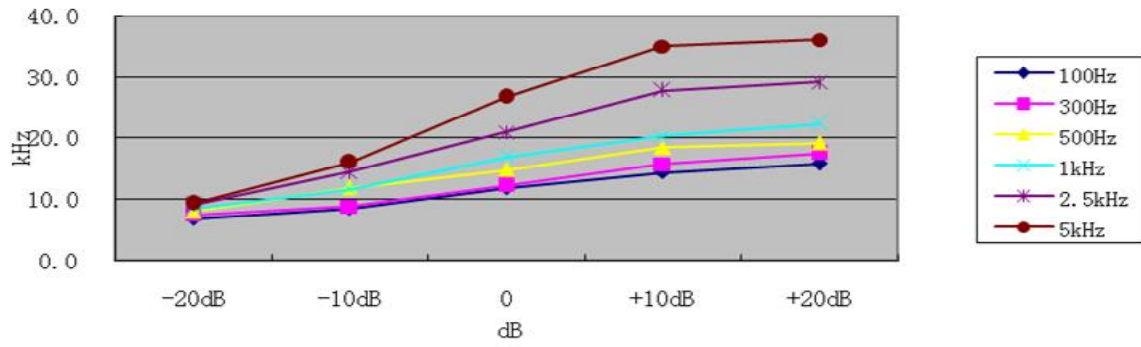

### 3.3 Photographs

#### 3.3.1 Radiated Emission Test Setup

30MHz - 1GHz

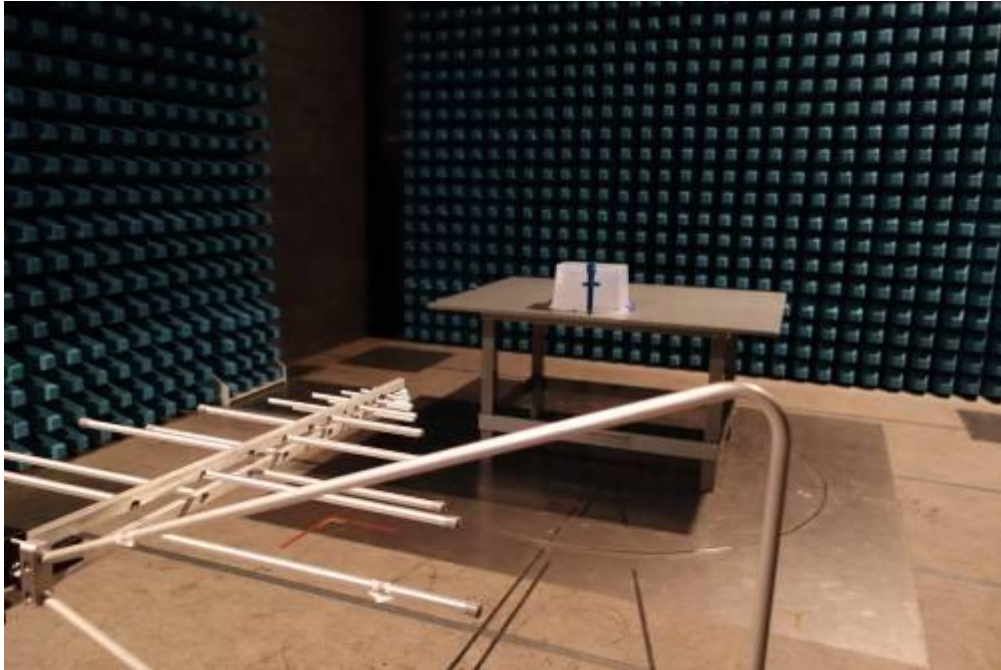

Above 1GHz



### 3.3.2 EUT Constructional Details

#### M-600







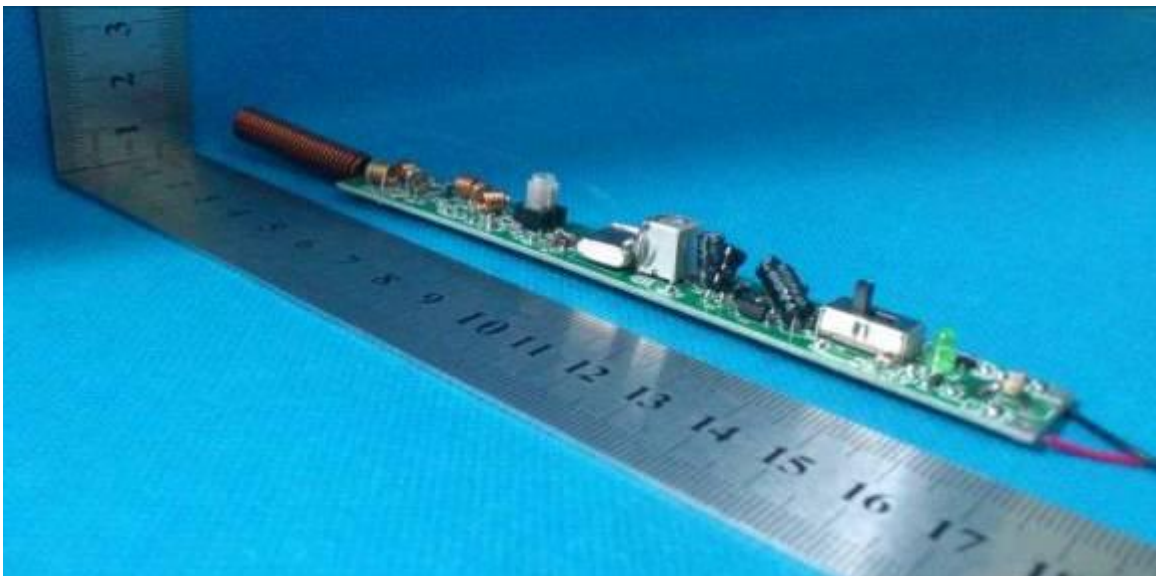
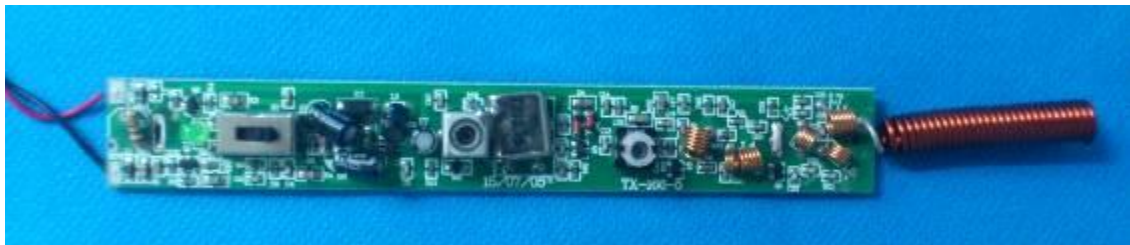
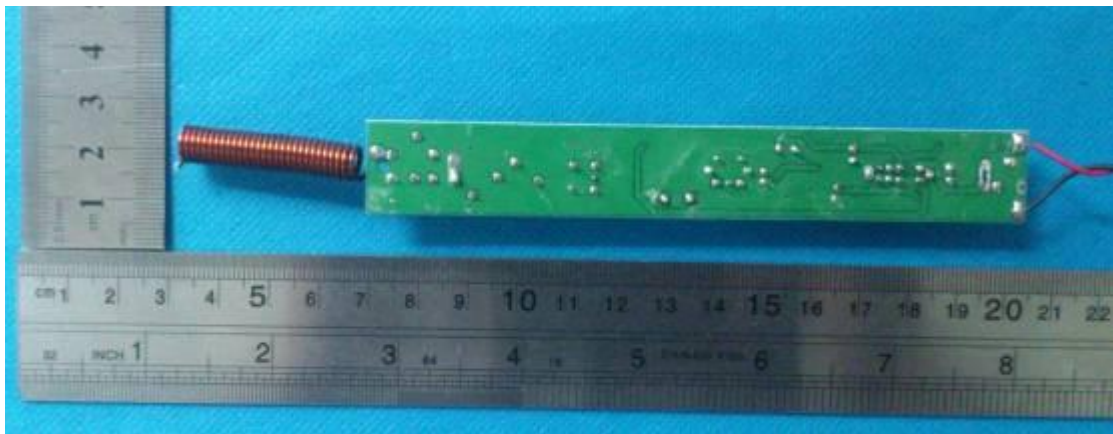
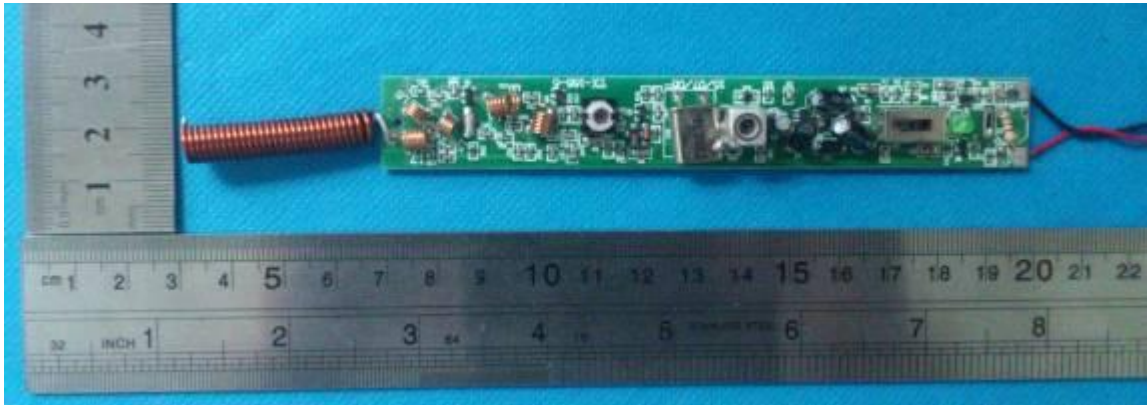

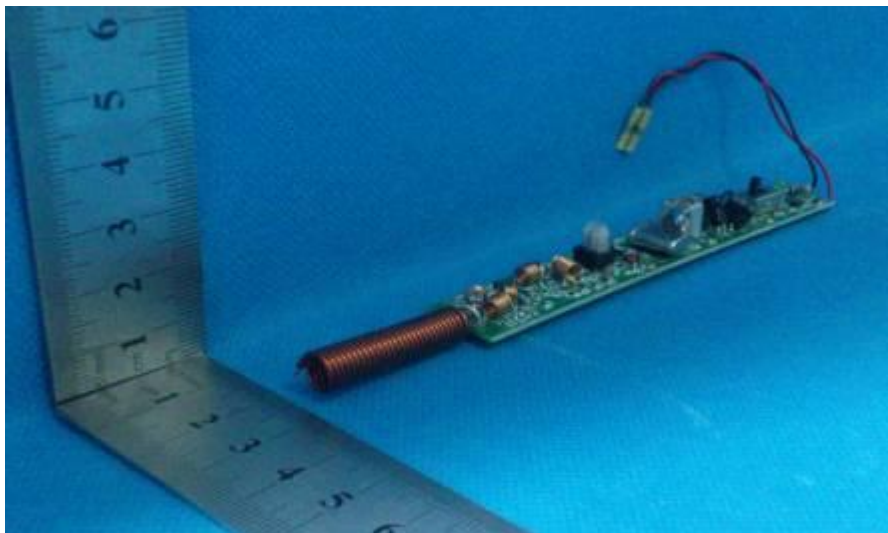
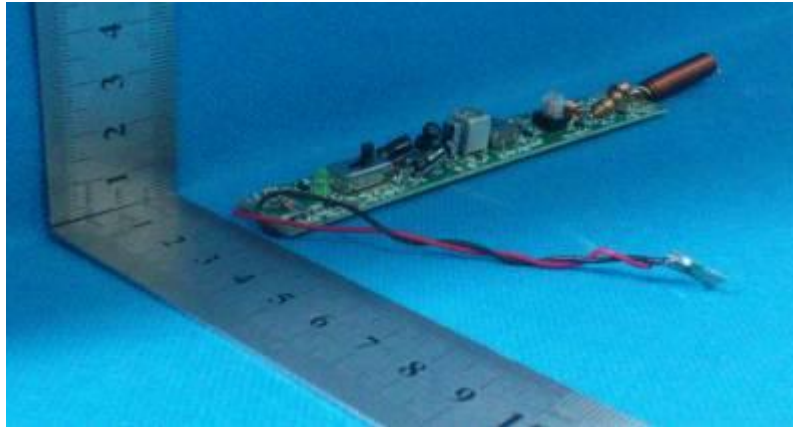
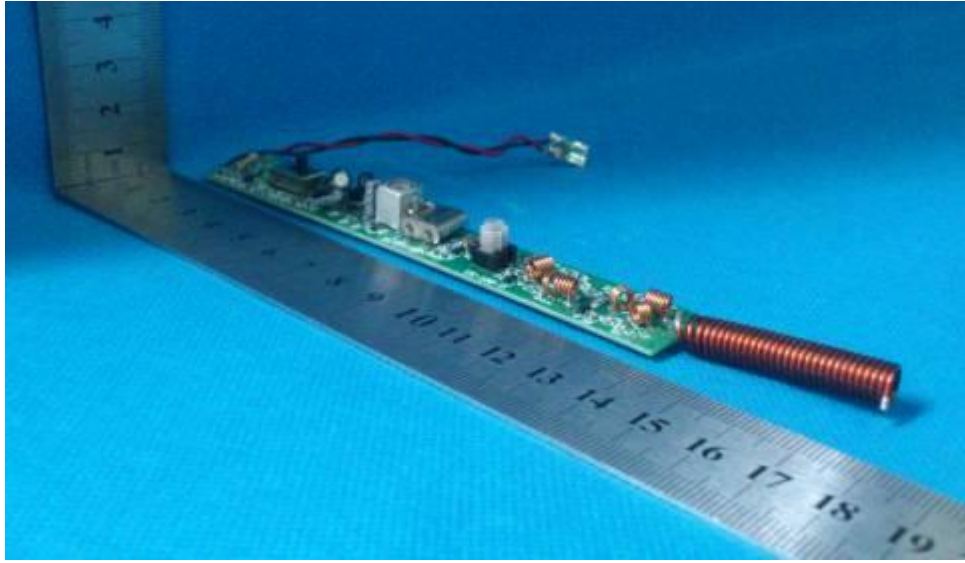



### 3.3.3 Antenna Photo

Antenna

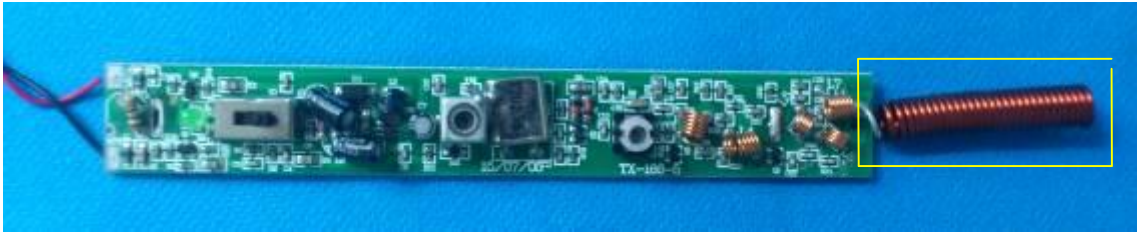

#### 4 EQUIPMENTS USED DURING TEST

Item	Test Equipment	Manufacturer	Model No.	Inventory No.	Cal. Date	Cal. Due date
1	RF Generator	Rohde & Schwarz	SMB100A-B106	1.031	2015-5-10	2016-5-10
2	Spectrum Analyzer	Rohde & Schwarz	FSP30	EMC0001	2016-3-24	2017-3-24
3	EMI Test Receiver	Rohde & Schwarz	ESCI	EMC1002	2016-3-24	2017-3-24
4	2-Channel Power Meter	Rohde & Schwarz	NRP2	1.033	2015-5-10	2016-5-10
5	Audio Analyzer	Hewlett Packard	8903B	EMC0011	2015-11-5	2016-11-5
6	Power Sensor	Rohde & Schwarz	NRP-Z91	1.034	2015-5-10	2016-5-10
7	Power Sensor	Rohde & Schwarz	NRP-Z91	1.035	2015-5-10	2016-5-10
8	Temperature Chamber	Gongwen	GDS-250	SFT0009	2015-11-5	2016-11-5
9	D.C. Power Supply	KIKUSUI	PAN35-10A	SFT0319	2015-11-5	2016-11-5
10	Temperature Chamber	Gongwen	GDS-250	SFT0009	2015-11-5	2016-11-5
11	D.C. Power Supply	KIKUSUI	PAN35-10A	SFT0319	2015-11-5	2016-11-5
12	Humidity/ Temperature Meter	Anymetre	TH101B	SFT0063	2015-11-5	2016-11-5
13	Barometer	ChangChun	DYM3	SEL0088	2015-6-8	2016-6-8
14	Multimeter	UNI-T	UT70A	EMC0017	2015-11-5	2016-11-5
15	Monopole Antenna	HST	N/A	EMC0089	2015-11-5	2016-11-5
16	Low loss coaxial cable	HST	2 m	EMC1008	2015-11-5	2016-11-5
17	Monopole Antenna	HST	N/A	N/A	2015-11-5	2016-11-5
18	Noise Generator	Ningbo Zhongce	DF1681	EMC0009	2015-11-5	2016-11-5
19	Spectrum Analyzer	R&S	FSP30	1.003	2015-7-30	2016-7-30
20	Biconilog Antenna	Schwarzbeck	VULB9163	1.011	2015-5-22	2016-5-22
21	3m Semi-anechoic Chamber	Albatross Projecets Gm	SAC-3M	1.001	2015-10-9	2017-10-9
22	EMI Receiver	R & S ESCI-3	ESCI-3	1.002	2015-7-30	2016-7-30
23	1G-18GHz Double Ridged Guide Antenna	R & S	HF906		2015-05-10	2017-05-10
24	Loop Antenna	BJ 2nd Factory	ZN30900A	EMC6001	2013-7-29	2016-7-29

\*\*\*End of report\*\*\*