

Telink

Datasheet for Telink Multi-Standard Wireless SoC TLSR9528

DS-TLSR9528-E10

Ver 0.6.0

2023/06/30

Keyword

Bluetooth BR, EDR; Bluetooth LE; Indoor positioning; Bluetooth LE Mesh; Zigbee; HomeKit; 6LoWPAN; Thread; Matter; 2.4 GHz

Brief

This datasheet is dedicated for Telink multi-standard wireless SoC TLSR9528.

In this datasheet, function block diagram, key features, typical applications, electrical specifications and details of each function module for TLSR9528 are introduced.

Published by
Telink Semiconductor

Bldg 3, 1500 Zuchongzhi Rd,
Zhangjiang Hi-Tech Park, Shanghai, China

© **Telink Semiconductor**
All Rights Reserved

Legal Disclaimer

This document is provided as-is. Telink Semiconductor reserves the right to make improvements without further notice to this document or any products herein. This document may contain technical inaccuracies or typographical errors. Telink Semiconductor disclaims any and all liability for any errors, inaccuracies or incompleteness contained herein.

Copyright © 2023 Telink Semiconductor (Shanghai) Co., Ltd.

Information

For further information on the technology, product and business term, please contact Telink Semiconductor Company (www.telink-semi.com).

For sales or technical support, please send email to the address of:

telinksales@telink-semi.com

telinksupport@telink-semi.com

Revision History

Version	Change Description
0.1.0	Preliminary release
0.1.1	<ul style="list-style-type: none"> • Revised “BLE” to “Bluetooth LE” • Chapter 1 Overview: Removed extra “including” from standard/specification compliance description • 1.1 Block Diagram: Updated Security module of Figure 1-1 • 1.2.1 General Features: Updated the description of Unique ID (UID), microcontroller, security solution, and I2S; revised GPIO number • 1.2.3 UWB Transceiver Sub-system Features: Updated the description of high accuracy ranging and distance measurement • 1.2.4 Features of Power Management Module: Updated the description of VBAT communication • 1.2.5 Flash Features: Added the feature description of TWS audio • 1.2.10 Wireless Audio Features: Updated the description of audio codecs
0.1.2	<ul style="list-style-type: none"> • 1.1 Block Diagram: Updated SRAM size to 256 KB • 1.2.1 General Features: Updated SRAM size to 256 KB and retention SRAM to 64 KB • 1.2.10 Wireless Audio Features: Added AAC to audio codec description, updated the description of Bluetooth specifications, and added the feature description of Keyword Spotting (KWS) and command word local recognition • 1.3 Typical Applications: Updated the description of typical applications • 2.3 DC Characteristics: Removed the current of Deep sleep with 16 KB SRAM retention and added the current of Deep sleep with 64 KB SRAM retention in Table 2-3

Version	Change Description
0.1.3	<ul style="list-style-type: none"> • 1.1 Block Diagram: Added QDEC to Figure 1-1; updated SRAM size to 512 KB and added voice activity detection, capacity touch button interface, QDEC to the description of the system • 1.2.1 General Features: Added the cache size for instruction and data cache controller; updated maximum flash size, SRAM size, bit width of RSA; removed AES-CCM support; added a low-frequency 2 MHz ~ 4 MHz clock to RTC and other timers; updated GPIO number, SPI channels, DMIC, AMIC, I2S, stereo audio codec, I2C, UART and package; added QDEC and capacity touch button interface • 1.2.3 UWB Transceiver Sub-system Features: Updated TX output power for EDR mode • 1.2.4 Features of Power Management Module: Updated power consumption • 1.2.5 Flash Features: Updated Bluetooth ISO channel support and removed audio support • 1.2.9 HomeKit Features: Updated Apple HomeKit ADK support • 1.2.10 Wireless Audio Features: Updated the maximum sampling rate of stereo audio codec and added voice activity detection <hr/> <ul style="list-style-type: none"> • 2.3 DC Characteristics: Updated Table 2-3 • 2.4 AC Characteristics: Updated TX output power for EDR mode in Table 2-5
0.5.0	<ul style="list-style-type: none"> • Chapter 1 Overview: added 1.4 Ordering Information, 1.6 Pin Layout • Chapter 2 Electrical Specifications: updated 2.4 AC Characteristics, added 2.1 Absolute Maximum Rating, 2.2 Recommended Operating Conditions, 2.4.2.1 Analog Input to Digital Output, 2.4.2.2 Digital Input to Analog Output, 2.4.2.4 Digital Microphone Interface Characteristics, 2.4.2.4 Digital Microphone Interface Characteristics, 2.5 Flash Characteristics • Added Chapter 3 to Chapter 21
0.5.1	<ul style="list-style-type: none"> • Updated features of AES in Chapter 17 AES and ECC in Chapter 18 Public Key Engine (PKE).
0.5.2	<ul style="list-style-type: none"> • Added TLSR9528B related information and flash features, updated Bluetooth 5.2 to 5.3 • Added 1.2.2 CPU and Memory, updated 1-1 Ordering Information of TLSR9528, added tables from Table 1-9 PWM Signal Description to Table 1-27 Crystal Signal Description • Updated Figure 3-1 Reference Schematic of TLSR9528A and Table 3-13 BOM Table for TLSR9528A Reference Design • Updated 4.1.2 Flash, 4.2 MCU with DSP extension • Added 10.3 JTAG and SDP • Updated Figure 15-1 Block Diagram of Low Power Comparator and Table 15-1 Analog Register Related to Low Power Comparator
0.5.3	<ul style="list-style-type: none"> • Updated Figure 1-5 Pin Assignment of TLSR9528B and Table 1-5 Pin Function of TLSR9528B • Updated 4.5.3 LDO and DCDC
0.5.4	<ul style="list-style-type: none"> • Added TLSR9528T related information, Figure 1-6 Pin Assignment of TLSR9528T, Table 1-9 Pin Function of TLSR9528T

Version	Change Description
0.5.5	<ul style="list-style-type: none">• Added reference schematic and BOM for TLSR9528B in Chapter 3 Reference Design• Added 11.1.9 GPIO Driving LED Description• Updated 4.1.3 eFuse, Figure 4-3 Initial Power-up Sequence, 4.6 Wakeup Source, 11.1.2 Connection Relationship between GPIO and Related Modules, Chapter 16 Secure Boot, Firmware Encryption and Debug Lock
0.6.0	<ul style="list-style-type: none">• Added 8.4 Platform-Level Machine Timer (PLMT), 9.1 Trap, 9.2 Platform-Level Interrupt Controller (PLIC), 9.3 Software Platform-Level Interrupt Controller (PLIC_SW), Chapter 10 DMA• Updated Chapter 5 Audio, 11.5 I2S, 11.10 UART

Table of Contents

1 Overview.....	23
1.1 Block Diagram.....	23
1.2 Key Features	24
1.2.1 General Features	24
1.2.2 CPU and Memory	25
1.2.3 RF Features.....	26
1.2.4 Features of Power Management Module.....	26
1.2.5 Flash Features	27
1.2.6 Bluetooth Features.....	27
1.2.7 Zigbee Features.....	27
1.2.8 OpenThread Features	27
1.2.9 HomeKit Features	28
1.2.10 Wireless Audio Features	28
1.2.11 Concurrent Mode Feature.....	28
1.3 Typical Applications	29
1.4 Ordering Information	29
1.5 Package	29
1.6 Pin Layout.....	32
2 Electrical Specifications	54
2.1 Absolute Maximum Rating.....	54
2.2 Recommended Operating Conditions	54
2.3 DC Characteristics	54
2.4 AC Characteristics	56
2.4.1 RF Performance	56
2.4.2 Audio Performance	65
2.4.2.1 Analog Input to Digital Output.....	65
2.4.2.2 Digital Input to Analog Output	65
2.5 Storage Conditions.....	65
3 Reference Design	67
3.1 Reference Schematic for TLSR9528A	67
3.2 BOM (Bill of Material) for TLSR9528A	67
3.3 Reference Schematic for TLSR9528B	68
3.4 BOM (Bill of Material) for TLSR9528B	69
3.5 Reference Schematic for TLSR9528T	70
3.6 BOM (Bill of Material) for TLSR9528T	71
4 Memory, MCU and PMU	72

4.1 Memory	72
4.1.1 SRAM	72
4.1.2 Flash	74
4.1.3 eFuse	74
4.1.4 Unique ID	75
4.2 MCU	75
4.2.1 Physical Memory Protection	75
4.3 Working Mode	78
4.4 Reset	81
4.5 Power Management	82
4.5.1 Power-on-Reset (POR) and Brown-out Detect	82
4.5.2 Working Mode Switch	86
4.5.3 LDO and DCDC	87
4.5.4 VBAT and VANT Power-Supply Mode	88
4.6 Wakeup Source	88
5 Audio	91
5.1 Audio CODEC	91
5.1.1 Introduction	91
5.1.2 CODEC Input Path	92
5.1.2.1 Decimation Data Path	92
5.1.2.2 Sample Rate of CODEC Input	94
5.1.2.3 Digital Gain of CODEC Input	94
5.1.3 CODEC Output Path	96
5.1.3.1 Data Path of CODEC Output	96
5.1.3.2 Sample Rate of CODEC Output	98
5.1.3.3 Digital Gain of CODEC Output	98
5.2 Audio FIFO	99
5.2.1 Introduction	99
5.2.2 RXFIFO	99
5.2.2.1 I2S Data Transfer in RXFIFO	101
5.2.2.2 CODEC Data Transfer in RXFIFO	102
5.2.3 TXFIFO	103
5.2.3.1 I2S Data Transfer in TXFIFO	105
5.2.3.2 CODEC Data Transfer in RXFIFO	105
5.3 Register Description	105
6 BT/BLE/2.4GHz RF Transceiver	116
6.1 Overview	116
6.2 Air Interface Data Rate and RF Channel Frequency	116

6.3 Baseband.....	117
6.3.1 Packet Format	117
6.3.2 BLE Location Function.....	118
6.3.3 RSSI and Frequency Offset.....	118
7 Clock	120
7.1 Clock Sources	120
7.2 System Clock	122
7.3 Module Clock	122
7.3.1 System Timer Clock	122
7.3.2 USB Clock	122
7.3.3 I2S0 Clock.....	122
7.3.4 I2S1 Clock	122
7.3.5 DMIC Clock	122
7.3.6 clkzb32k	123
7.3.7 clk_7816	123
7.3.8 clk_msppi.....	123
7.3.9 clk_lsppi	123
7.3.10 clk_gsppi	123
7.4 Register Table	123
8 Timer	127
8.1 Timer0 ~ Timer1	127
8.1.1 Mode 0 (System Clock Mode).....	127
8.1.2 Mode 1 (GPIO Trigger Mode).....	127
8.1.3 Mode 2 (GPIO Pulse Width Mode)	128
8.1.4 Mode 3 (Tick Mode)	129
8.1.5 Watchdog	129
8.1.6 Register Table	129
8.2 32K LTimer.....	131
8.3 System Timer.....	133
8.4 Platform-Level Machine Timer (PLMT)	134
8.4.1 Introduction	134
8.4.2 Access To Mtime	134
8.4.3 Access To Mtimecmp	135
8.4.4 Register Description	135
9 Trap and PLIC.....	136
9.1 Trap	136
9.1.1 Introduction.....	136
9.1.2 Interrupt	136

9.1.2.1	Local Interrupts	136
9.1.2.2	Interrupt Status and Masking	137
9.1.2.3	Interrupt Priority	137
9.1.3	Exception	137
9.1.4	Trap Handling	138
9.1.4.1	Entering the Trap Handler	138
9.1.4.2	Returning from the Trap Handler	138
9.1.5	Machine Trap Related CSRs	138
9.1.5.1	Machine Status	138
9.1.5.2	Machine Interrupt Enable	139
9.1.5.3	Machine Trap Vector Base Address	139
9.1.5.4	Machine Exception Program Counter	140
9.1.5.5	Machine Cause Register	140
9.1.5.6	Machine Trap Value	141
9.1.5.7	Machine Interrupt Pending	142
9.1.5.8	Machine Detailed Trap Cause	142
9.1.5.9	Machine Miscellaneous Control Register	143
9.2	Platform-Level Interrupt Controller (PLIC)	144
9.2.1	Introduction	144
9.2.2	External Interrupt Sources	146
9.2.3	Support for Preemptive Priority Interrupt	147
9.2.3.1	Interrupt Claims with Preemptive Priority	147
9.2.3.2	Interrupt Completion with Preemptive Priority	147
9.2.3.3	Programming Sequence to Allow Preemption of Interrupts	147
9.2.4	Vectored Interrupts	149
9.2.5	Support for Software-Generated Interrupt	149
9.2.6	Interrupt Flow	149
9.2.7	Register Description	150
9.3	Software Platform-Level Interrupt Controller (PLIC_SW)	152
9.3.1	Introduction	152
9.3.2	Register Description	152
10	DMA	154
10.1	Introduction	154
10.1.1	Function Description	154
10.1.1.1	Channel Arbitration	155
10.1.1.2	Chain Transfer	155
10.1.1.3	Data Order	156
10.2	Registers	156

10.2.1 Register Summary	156
10.2.2 Interrupt Status Register (Offset 0x30)	157
10.2.3 Channel Abort Register (Offset 0x40)	158
10.2.4 Channel n Control Register (Offset 0x44+n*0x14).....	158
10.2.5 Channel n Source Address Register (Offset 0x48+n*0x14).....	162
10.2.6 Channel n Destination Address Register (Offset 0x4C+n*0x14)	162
10.2.7 Channel n Transfer Size Register (Offset 0x50+n*0x14).....	163
10.2.8 Channel n Linked List Pointer Register (Offset 0x54+n*0x14)	163
10.2.9 Baseband Related Register	163
10.2.10 Miscellaneous Register	166
10.3 Usage Guide	166
10.3.1 From SRAM to SRAM.....	166
10.3.2 From SRAM to Peripherals.....	167
10.3.3 From Peripherals to SRAM.....	168
10.3.4 From SRAM to Baseband.....	169
10.3.5 From Baseband to SRAM.....	170
11 Interface	171
11.1 GPIO	171
11.1.1 Basic Configuration	171
11.1.2 Connection Relationship between GPIO and Related Modules	179
11.1.3 Drive Strength	182
11.1.4 Polarity.....	183
11.1.5 GPIO IRQ Signal.....	183
11.1.6 GPIO2RISC IRQ Signal.....	183
11.1.7 GPIO GROUP IRQ Signal.....	185
11.1.8 Pull-up/Pull-down Resistors	185
11.1.9 GPIO Driving LED Description.....	187
11.2 Swire	187
11.3 JTAG and SDP	188
11.4 I2C.....	188
11.4.1 Communication Protocol	189
11.4.2 I2C Slave Mode	189
11.4.3 I2C Master Mode.....	190
11.4.3.1 I2C Master Write Transfer in NDMA Mode.....	190
11.4.3.2 I2C Master Read Transfer in NDMA Mode.....	190
11.4.3.3 I2C Master Writer Transfer in DMA Mode	191
11.4.3.4 I2C Master Read Transfer in DMA Mode	191
11.4.4 Register Description	191

11.5 I2S.....	195
11.5.1 Introduction	195
11.5.2 I2S Protocol	195
11.5.2.1 I2S Format	196
11.5.2.2 LJ Format.....	196
11.5.2.3 RJ Format	197
11.5.2.4 DSP Format (Mode A)	197
11.5.2.5 DSP Format (Mode B)	198
11.5.3 I2S Clock	198
11.5.4 I2S Synchronization	200
11.5.5 I2S Registers	200
11.6 Memory SPI.....	203
11.6.1 Memory SPI Diagram	203
11.6.2 MSPI Register Description	203
11.7 LSPI	208
11.7.1 LSPI Diagram.....	208
11.7.2 LSPI Register Description	209
11.8 GSPI.....	219
11.8.1 GSPI Diagram	219
11.8.2 GSPI Register Description	220
11.9 SPI Slave (SPI_SLV)	228
11.9.1 Diagram.....	228
11.9.2 Features	229
11.9.3 Function Description	229
11.10 UART.....	230
11.10.1 Introduction	230
11.10.2 Block Diagram	231
11.10.3 Function Description	231
11.10.3.1 Pin Configuration	231
11.10.3.2 Transmitter	231
11.10.3.3 Receiver	232
11.10.3.4 Baud Rate Generator.....	232
11.10.3.5 Loopback Mode	233
11.10.3.6 Error Conditions.....	234
11.10.3.7 Hardware Flow Control	234
11.10.3.8 Receiver Timeout	234
11.10.4 Register Description.....	235
11.11 USB	240

12 PWM	248
12.1 Enable PWM	248
12.2 Set PWM Clock	248
12.3 PWM Waveform, Polarity and Output Inversion	248
12.3.1 Waveform of Signal Frame.....	248
12.3.2 Invert PWM Output.....	249
12.3.3 Polarity for Signal Frame	249
12.4 PWM Mode	249
12.4.1 Select PWM Modes	249
12.4.2 Continuous Mode	249
12.4.3 Counting Mode	250
12.4.4 IR Mode	250
12.4.5 IR FIFO Mode.....	251
12.4.6 IR DMA FIFO Mode	252
12.5 PWM Interrupt	253
12.6 PWM Center Align Mode.....	253
12.7 Register Description	254
13 SAR ADC	258
13.1 Power On/Down	258
13.2 ADC Clock	258
13.3 ADC Control in Auto Mode.....	258
13.3.1 Set Max State and Enable Channel.....	258
13.3.2 "Set" State	259
13.3.3 "Capture" State	259
13.3.4 Usage Case with Detailed Register Setting.....	260
13.4 Battery Voltage Sampling	261
13.5 Register Table	261
14 Temperature Sensor.....	266
15 Low Power Comparator	267
15.1 Power On/Down	267
15.2 Select Input Channel.....	267
15.3 Select Mode and Input Channel for Reference	268
15.4 Select Scaling Coefficient	268
15.5 Low Power Comparator Output	268
15.6 Register Description	268
16 Secure Boot, Firmware Encryption and Debug Lock	271
16.1 Key Management.....	271
16.2 Flash Space and eFuse Definition	272

16.2.1 Flash Space in Secure Boot Mode	272
16.2.2 eFuse Definition in Secure Boot Mode.....	273
16.2.3 Use of Debug Key	273
16.3 Usage	273
17 AES	275
18 Public Key Engine (PKE)	277
18.1 Calculation Model Overview	277
18.2 Function Description	277
18.2.1 Module Description	277
18.2.2 Software Interface (Programming Model)	278
18.3 Register Description	280
19 PTA Interface	285
19.1 BLE Two-Wire Signaling	285
19.2 BLE Three-Wire or Four-Wire Signaling	286
19.3 BT Three-Wire or Four-Wire Signaling.....	288
20 Quadrature Decoder	291
20.1 Input Pin Selection	291
20.2 Common Mode and Double Accuracy Mode.....	291
20.3 Read Real Time Counting Value.....	293
20.4 QDEC Reset	294
20.5 Other Configuration	294
20.6 Timing Sequence	295
20.7 Register Table	296
21 True Random Number Generator (TRNG)	297
21.1 Model Overview.....	297
21.2 Interrupt Description	297
21.2.1 CPU Reads RBG_DR without Data	297
21.2.2 Data Valid	298
21.3 Usage Procedure	298
21.3.1 Normal Operation.....	298
21.3.2 Entropy Source	298
21.4 Register Description	298

List of Figures

Figure 1-1 Block Diagram of the System	23
Figure 1-2 Package of TLSR9528A/T	30
Figure 1-3 Package of TLSR9528B	31
Figure 1-4 Pin Assignment of TLSR9528A	33
Figure 1-5 Pin Assignment of TLSR9528B	37
Figure 1-6 Pin Assignment of TLSR9528T	42
Figure 3-1 Reference Schematic of TLSR9528A	67
Figure 3-2 Reference Schematic of TLSR9528B	69
Figure 3-3 Reference Schematic of TLSR9528T	70
Figure 4-1 Memory Map	73
Figure 4-2 Control Logic of Power up/down	82
Figure 4-3 Initial Power-up Sequence	84
Figure 4-4 Initial Power-down Sequence	85
Figure 4-5 LDO and DCDC	87
Figure 4-6 Wake up Sources	88
Figure 5-1 Audio CODEC	91
Figure 5-2 CODEC Input Path	92
Figure 5-3 Audio CODEC Decimation	93
Figure 5-4 Audio ALC Path	93
Figure 5-5 Structure of Average Filter	93
Figure 5-6 Signals before and after ALC	94
Figure 5-7 Data Path of CODEC Output	96
Figure 5-8 Sidetone Structure	97
Figure 5-9 Block Diagram of Audio FIFO	99
Figure 5-10 RXFIFO Input	100
Figure 5-11 I2S Data Transfer in RXFIFO	101
Figure 5-12 TXFIFO Output Structure	104

Figure 6-1 Block Diagram of RF Transceiver.....	116
Figure 7-1 Clock Sources.....	120
Figure 8-1 Block Diagram of PLMT	134
Figure 9-1 Block Diagram of Interrupt	136
Figure 9-2 Block Diagram of PLIC	144
Figure 9-3 Detailed Block Diagram of PLIC	145
Figure 9-4 Interrupt Flow	149
Figure 9-5 Block Diagram of PLIC_SW	152
Figure 10-1 Example of DMA Data Transfers	154
Figure 10-2 Linked List Structure for Chain Transfers.....	155
Figure 11-1 Logic Relationship between GPIO and Related Modules	179
Figure 11-2 Detailed Circuit for Part A.....	180
Figure 11-3 Detailed Circuit for Part B.....	181
Figure 11-4 Detailed Circuit of Part C.....	182
Figure 11-5 One GPIO drives two LEDs.....	187
Figure 11-6 I2C Timing	189
Figure 11-7 Byte Consisted of Slave Address and R/W Flag Bit	189
Figure 11-8 Read Format in Slave Mode	190
Figure 11-9 Write Format in Slave Mode	190
Figure 11-10 Timing Diagram of I2S Format.....	196
Figure 11-11 Timing Diagram of LJ Format.....	197
Figure 11-12 Timing Diagram of RJ Format	197
Figure 11-13 Timing Diagram of DSP Format Mode A	198
Figure 11-14 Timing Diagram of DSP Format Mode B	198
Figure 11-15 Clock Tree of I2S0 Module	199
Figure 11-16 Phase Relationship between i2s0_clk and i2s1_clk	200
Figure 11-17 Memory SPI Diagram	203
Figure 11-18 LSPI Diagram.....	209
Figure 11-19 GSPI Diagram	220

Figure 11-20 SPI_SLV Diagram	229
Figure 11-21 SPI_SLV Write Format.....	229
Figure 11-22 SPI_SLV Read Format	229
Figure 11-23 Block Diagram of UART	231
Figure 11-24 UART Protocol Formats and Sampling Point	233
Figure 11-25 Hardware Flow Control between 2 UARTs	234
Figure 11-26 Timeout Flag Used for Data Transmission	235
Figure 12-1 Signal Frame	248
Figure 12-2 PWM Output Waveform Chart	249
Figure 12-3 Continuous Mode	250
Figure 12-4 Counting Mode (n=0)	250
Figure 12-5 IR Mode (n=0)	251
Figure 12-6 IR Format Examples	252
Figure 12-7 Center Align Mode	253
Figure 13-1 Diagram of ADC	258
Figure 14-1 Block Diagram of Temperature Sensor	266
Figure 15-1 Block Diagram of Low Power Comparator	267
Figure 16-1 Key Management	271
Figure 16-2 Flash Space for Secure Boot	272
Figure 17-1 AES Address	275
Figure 18-1 Block Diagram of PKE Module	278
Figure 19-1 BLE Two-Wire Signaling	285
Figure 19-2 Example of BLE Two-Wire PTA Timing Diagram	285
Figure 19-3 BLE Three-Wire or Four-Wire Signaling.....	286
Figure 19-4 Example of BLE Four-Wire PTA Timing Diagram	287
Figure 19-5 BT Three-Wire or Four-Wire Signaling	288
Figure 19-6 Example of BT Four-Wire PTA Timing Diagram	289
Figure 20-1 Common Mode.....	292
Figure 20-2 Double Accuracy Mode.....	293

Figure 20-3 Read Real Time Counting Value	294
Figure 20-4 Shuttle Mode	294
Figure 20-5 Timing Sequence Chart	295
Figure 21-1 Module Structure.....	297

List of Tables

Table 1-1 Ordering Information of TLSR9528	29
Table 1-2 Mechanical Dimension of TLSR9528A/T	30
Table 1-3 Mechanical Dimension of TLSR9528B	31
Table 1-4 Pin Function of TLSR9528A.....	33
Table 1-5 Pin Function of TLSR9528B.....	37
Table 1-6 Pin Function of TLSR9528T	42
Table 1-7 GPIO Pin Mux of TLSR9528	46
Table 1-8 Flash IO Pin Mux	48
Table 1-9 PWM Signal Description	48
Table 1-10 I2C Signal Description	49
Table 1-11 I2S Signal Description	49
Table 1-12 UART Signal Description	49
Table 1-13 GSPI Signal Description	50
Table 1-14 LSPI Signal Description.....	50
Table 1-15 SPI Slave Signal Description	50
Table 1-16 7816 Signal Description	51
Table 1-17 DMIC Signal Description	51
Table 1-18 Swire Signal Description	51
Table 1-19 External Power Amplifier, Low Noise Amplifier Signal Description	51
Table 1-20 USB Signal Description	51
Table 1-21 JTAG Signal Description	51
Table 1-22 SDP Signal Description.....	52
Table 1-23 PTA Signal Description.....	52
Table 1-24 ATSEL Signal Description	52
Table 1-25 Low Current Comparator Signal Description	52
Table 1-26 SAR ADC Signal Description.....	53
Table 1-27 Crystal Signal Description	53

Table 2-1 Absolute Maximum Rating	54
Table 2-2 Recommend Operating Conditions	54
Table 2-3 RX/TX Current and Sleep Current	55
Table 2-4 Digital Inputs/Outputs	55
Table 2-5 RF Performance Characteristics	56
Table 2-6 USB Characteristics	63
Table 2-7 RSSI Characteristics	63
Table 2-8 Crystal Characteristics	63
Table 2-9 RC Oscillator Characteristics	64
Table 2-10 ADC Characteristics	64
Table 2-11 Analog Microphone / Line Input to ADC Path	65
Table 2-12 Audio DAC to Headphone Output Path	65
Table 3-1 BOM Table for TLSR9528A Reference Design	67
Table 3-2 BOM Table for TLSR9528B Reference Design	69
Table 3-3 BOM Table for TLSR9528T Reference Design	71
Table 4-1 eFuse Definition	74
Table 4-2 PMP Configuration Registers	76
Table 4-3 PMPiCFG Description	77
Table 4-4 PMP Address Registers	77
Table 4-5 D25 NAPOT Range Encoding in PMP Address and Configuration Registers	78
Table 4-6 Working Mode	79
Table 4-7 Retention Analog Registers in Deep Sleep	80
Table 4-8 Register Configuration for Software Reset	81
Table 4-9 Analog Register to Control Logic of Power Up/Down	83
Table 4-10 Characteristics of Initial Power-up/Power-down Sequence	85
Table 4-11 3.3 V Analog Register for Module Power up/down Control	86
Table 4-12 Analog Register for Wakeup	89
Table 5-1 Sample Rate of CODEC Input	94
Table 5-2 PGA Gain for Different Configurations	95

Table 5-3 Digital Gain for Different Configurations	95
Table 5-4 Gain of Sidetone	97
Table 5-5 Sample Rate of CODEC Output	98
Table 5-6 Register of ain0_sel and ain1_sel.....	100
Table 5-7 Data format of i2s0_ain0_come	101
Table 5-8 Data format of i2s1_ain0_come.....	102
Table 5-9 Data Structure of two Synchronization Mode	102
Table 5-10 Data format of dec0_ain0_come and dec1_ain0_come	103
Table 5-11 Data Format in RXFIFO.....	103
Table 5-12 Register of aout0_sel and aout1_sel	104
Table 5-13 Data format of i2s0_aout_come.....	105
Table 5-14 Audio Related Registers	105
Table 5-15 CODEC Related Registers	109
Table 6-1 Packet Format in Standard 1 Mbps BLE Mode.....	117
Table 6-2 Packet Format in Standard 2 Mbps BLE Mode	117
Table 6-3 Packet Format in Standard 500 kbps/125 kbps BLE Mode.....	117
Table 6-4 Packet Format in 802.15.4 Mode.....	117
Table 6-5 Packet Format in Proprietary Mode	118
Table 6-6 Packet Format of Basic Rate Packets	118
Table 6-7 Packet Format of Enhanced Data Rate Packet	118
Table 7-1 Clock Sources of Each Module	121
Table 7-2 Clock Related Registers.....	123
Table 8-1 Registers for Timer 0 ~ Timer 1.....	130
Table 8-2 32K LTimer Related Registers.....	132
Table 8-3 System Timer Related Registers	133
Table 8-4 PLMT Related Registers.....	135
Table 9-1 Interrupt Priority	137
Table 9-2 Register Description of mstatus	139
Table 9-3 Register Description of mie.....	139

Table 9-4 Register Description of mtvec.....	140
Table 9-5 Register Description of mepc	140
Table 9-6 Register Description of mcause	140
Table 9-7 Possible Values of mcause.....	140
Table 9-8 Possible values of mcause after reset.....	141
Table 9-9 Possible values of mcause after vector interrupt	141
Table 9-10 Register Description of mtval.....	142
Table 9-11 Register Description of mip.....	142
Table 9-12 Register Description of mdcause	142
Table 9-13 Detailed mdcause meaning in different mcause condition	143
Table 9-14 Register Description of mdcause	144
Table 9-15 Interrupt Sources	146
Table 9-16 Register Configuration for PLIC	150
Table 9-17 Register Configuration for PLIC_SW	153
Table 10-1 Format of Linked List Descriptor.....	156
Table 10-2 DMA Register Summary.....	156
Table 10-3 Interrupt Status Register	157
Table 10-4 Channel Abort Register.....	158
Table 10-5 Channel n Control Register	158
Table 10-6 Request/Ack Handshake Pair for Hardware Connection.....	161
Table 10-7 Channel n Source Address Register	162
Table 10-8 Channel n Destination Address Register	162
Table 10-9 Channel n Transfer Size Register.....	163
Table 10-10 Channel Linked List Pointer Register.....	163
Table 10-11 Baseband Related Registers.....	163
Table 10-12 Linked List Interrupt Mode.....	166
Table 10-13 Register Configuration for SRAM to SRAM.....	166
Table 10-14 Register Configuration for SRAM to Peripherals.....	167
Table 10-15 Register Configuration for Peripherals to SRAM.....	168

Table 11-1 GPIO Pad Function Mux	171
Table 11-2 Flash IO Pin Mux	173
Table 11-3 GPIO Setting	173
Table 11-4 GPIO Function Mux Configuration Registers.....	177
Table 11-5 GPIO IRQ Table	183
Table 11-6 Analog Registers for Pull-up/Pull-down Resistor Control	185
Table 11-7 Swire Related Registers	188
Table 11-8 I2C Related Registers	191
Table 11-9 Frame Clock and MSB Position	195
Table 11-10 I2S Related Registers.....	201
Table 11-11 Memory SPI Related Registers	204
Table 11-12 LSPI Related Registers	209
Table 11-13 GSPI Related Registers.....	220
Table 11-14 SPI_SLV Commands	230
Table 11-15 Clock Variation Tolerance Factor	233
Table 11-16 UART Related Registers	235
Table 11-17 USB Related Registers	241
Table 12-1 PWM Registers.....	254
Table 13-1 Overall Register Setting.....	260
Table 13-2 SAR ADC Registers	261
Table 14-1 Analog Register for Temperature Sensor.....	266
Table 15-1 Analog Register Related to Low Power Comparator.....	268
Table 16-1 eFuse Data for Secure Boot	273
Table 17-1 AES Related Registers	275
Table 18-1 Dual Port RAM Address Map.....	279
Table 18-2 PKE Related Registers.....	280
Table 19-1 Register Configuration for t1/t2	287
Table 19-2 Register Configuration for BT PTA	289
Table 20-1 Input Pin Selection.....	291

Table 20-2 Timing	295
Table 20-3 Register Table for QDEC	296
Table 21-1 TRNG Related Register	299

1 Overview

The TLSR9528 supports standards and industrial alliance specifications including Bluetooth basic rate (BR), enhanced data rate (EDR), low energy (LE), indoor positioning, Bluetooth LE Mesh, Zigbee 3.0, RF4CE, HomeKit, 6LoWPAN, Thread, Matter, 2.4 GHz proprietary, RFFE and Wi-Fi Coexistence Interface.

The TLSR9528 combines the features and functions needed for high quality wireless audio and wearable devices into a single System-on-Chip (SoC).

1.1 Block Diagram

The TLSR9528 is designed to offer high integration, ultra-low power application capabilities. The system's block diagram is as shown in Figure 1-1.

Figure 1-1 Block Diagram of the System

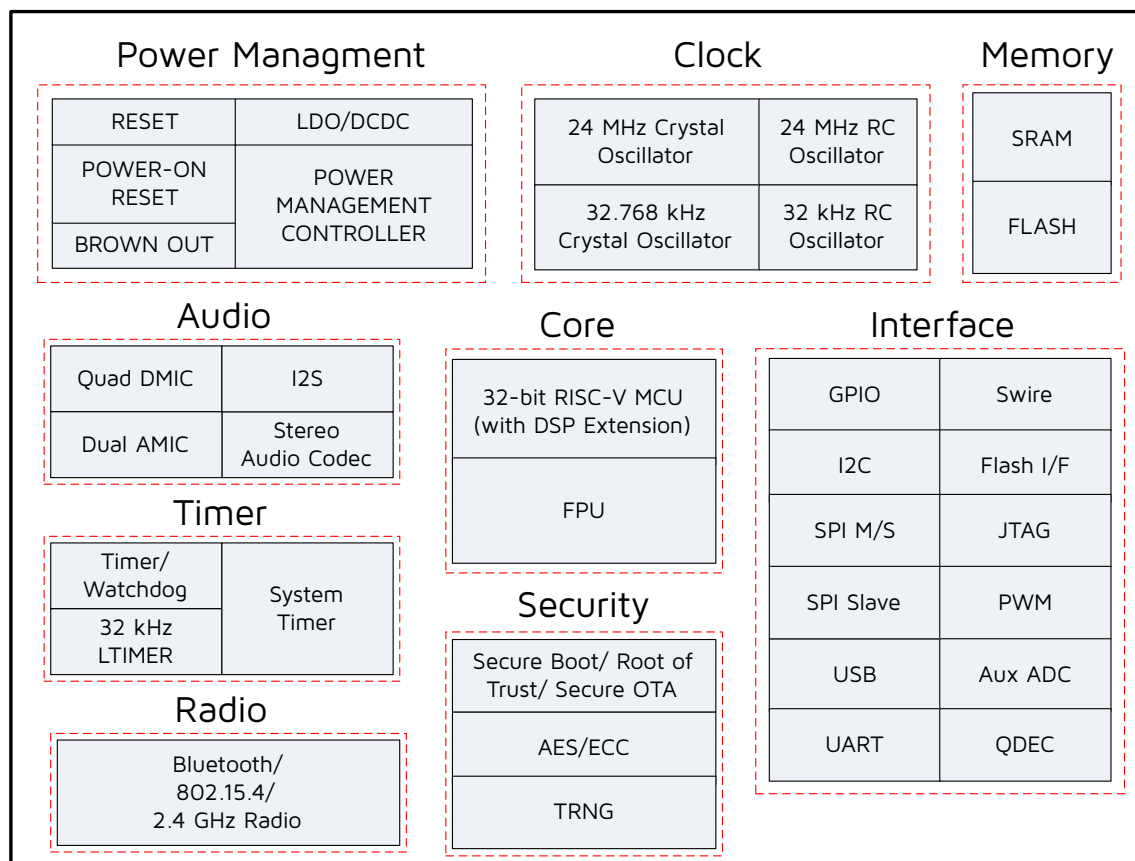

The TLSR9528 integrates a powerful 32-bit RISC-V (RISC-Five) MCU, 2.4 GHz ISM Radio, 512 KB SRAM, embedded 1 MB/2 MB/4 MB flash or external flash (depending on detailed parts, see section [1.4 Ordering Information](#)), stereo audio CODEC, Aux ADC, analog and digital microphone input, PWM, quadrature decoder (QDEC), flexible IO interfaces, and other peripheral blocks required for advanced audio applications.

The TLSR9528 also includes multi-stage power management design allowing ultra-low power operation and making it the ideal candidate for wearable and power-constraint applications.

With the high integration level of TLSR9528, few external components are needed to satisfy customers' complicated application requirements.

1.2 Key Features

1.2.1 General Features

General features are as follows:

1. Supports 128-bit Unique Chip ID
2. Security solution
 - Root of Trust
 - Secure Boot
 - Secure OTA
 - Firmware encryption
 - Secure Debug Port Control
 - Prevent any unauthorized or maliciously modified software from running
 - Signature and verification based on RSA1024
 - 1024-bit eFuse
 - Embedded hardware AES block cipher with 128 bit keys and software AES-CCM, supports ECB/CCM/GCM/CTR modes
 - Hardware acceleration for elliptical curve cryptography (ECC), supports ECDH and ECDSA
 - Hardware true random number generator (TRNG)
3. RTC and other timers
 - Clock source of 24 MHz & 32.768 kHz Crystal and 32 kHz / 24 MHz embedded RC oscillator
 - Two general 32-bit timers with four selectable modes in active mode
 - Watchdog timer
 - A low-frequency 32 kHz timer available in low power mode
 - A low-frequency 32 kHz Platform-Level Machine Timer (PLMT)
 - A low-frequency 2 MHz ~ 4 MHz clock configurable on 24 MHz RC oscillator in low power mode
4. A rich set of digital and analog interfaces
 - Up to 48 GPIOs
 - Configurable to select 2-wire SDP or 4-wire JTAG debug interface
 - 4 different SPI channels
 - MSPI: Memory SPI dedicated for NOR flash
 - Up to 64 MHz SPI clock
 - Supports quad/dual/signal data line
 - GSPI: Global SPI
 - Up to 48 MHz SPI clock
 - Supports quad/dual/single data line
 - Supports PSRAM interface
 - Supports NOR Flash interface
 - Supports 4-channel CS_N for Multi-SPI Slave
 - LSPI: LCD SPI
 - Up to 48 MHz SPI Clock

- Supports TFT panel interface
 - Supports TFT panel interface without internal RAM
 - SPI Slave: SPI Slave for external accessing
 - 4-channel DMIC (Digital Mic) and 2-channel AMIC (Analog Mic)
 - 2-channel I2S with 24-bit 48 kHz sample rate
 - Stereo audio codec with VAD (Voice Activity Detection)
 - 2-channel I2C
 - 2-channel UART with hardware flow control and 7816 protocol support
 - USB 2.0 Full Speed
 - Swire
 - Up to 6 channels of differential PWM
 - IR transmitter with DMA
 - One quadrature decoder (QDEC), two-phase input selectable
 - 10-channel (only GPIO input), 14-bit auxiliary ADC
 - Low power comparator
 - Internal 3-channel LED resistance
 - 2 channels are able to drive up to 8 mA
 - 1 channel is able to drive up to 4 mA
 - Shrink current resistance
 - IO voltage can be configured as 3.3V or 1.8V by configuring CFG_VIO
5. Operating temperature range: -40°C ~ +85°C
 6. Completely RoHS-compliant package
 - TLSR9528A, 88-pin QFN 10x10x0.75 mm
 - TLSR9528B, 104-ball BGA 6x4.4x0.96 mm
 - TLSR9528T, 88-pin QFN 10x10x0.75 mm
 7. Supports 2.4 GHz IoT standards into a single SoC, including Bluetooth, Bluetooth LE Mesh, Zigbee 3.0, Homekit, 6LoWPAN, Thread, Matter and 2.4 GHz proprietary technologies

1.2.2 CPU and Memory

1. 32-bit RISC-V (IMACFDP) micro-controller
 - Instruction and data cache controller (8K I-Cache and 8K D-Cache)
 - Maximum running speed up to 96 MHz
 - Integrated DSP extension instructions
 - Integrated "F" standard extensions for single-precision floating-point
2. Memory architecture
 - Program memory: Up to 4 MB external flash for TLSR9528A/T, embedded 2 MB flash or external flash for TLSR9528B
 - 512 KB SRAM including up to 96 KB retention SRAM
3. DSP features
 - SIMD Data Processing Instructions

- Partial-SIMD Data Processing Instructions
- 64-bit Profile Instructions
- Non-SIMD Instructions
- Overflow Status Manipulation Instructions

1.2.3 RF Features

RF features include:

1. Bluetooth/802.15.4/2.4 GHz RF transceiver in worldwide 2.4 GHz ISM band
2. Bluetooth compliant, BR 1 Mbps, EDR 2 Mbps and 3 Mbps, Bluetooth LE 1 Mbps and 2 Mbps, Long Range 125 kbps and 500 kbps
3. Bluetooth for High Accuracy Distance Measurement by hardware accelerator
4. High accuracy ranging and distance measurement with channel sounding
5. IEEE 802.15.4 compliant, 250 kbps
6. 2.4 GHz proprietary 1 Mbps/2 Mbps/250 kbps/500 kbps mode with Adaptive Frequency Hopping feature
7. RX sensitivity: -92 dBm @ BR mode, -93 dBm @ EDR 2 Mbps mode, -86.5 dBm @ EDR 3 Mbps mode, -96 dBm @ Bluetooth LE 1 Mbps mode, -93.5 dBm @ Bluetooth LE 2 Mbps mode, -100.5 dBm @ Long Range 125 kbps mode, -98.5 dBm @ Long Range 500 kbps mode, -99.5 dBm @ IEEE 802.15.4 250 kbps mode
8. TX output power: -24 to +10 dBm @ Bluetooth LE / BR mode, +7 dBm @ EDR mode
9. 50 Ω matched single-pin antenna input
10. RSSI monitoring with +/-1 dB resolution and ranging from -100 dBm to 0 dBm
11. Auto acknowledgment, retransmission and flow control
12. Supports full-function Bluetooth LE AoA/AoD location features
13. Supports PTA (Packet Traffic Arbitrator) for Wi-Fi co-existence

1.2.4 Features of Power Management Module

Features of power management module include:

1. Power supply
 - VBAT (battery): 1.9 V ~ 4.3 V
 - VBUS (USB): 4.5 V ~ 5.5 V
2. Battery monitor for low battery voltage detection
3. Brownout detection/shutdown and Power-On-Reset
4. Multiple-power-state to optimize power consumption
5. Low power consumption:
 - Whole chip, RX EDR mode: 4.8 mA @ 4.2 V DCDC
 - Whole chip, TX BR mode: 4.6 mA @ 0 dBm, 4.2 V DCDC
 - Whole chip, TX EDR mode: 6.0 mA @ 0 dBm, 4.2 V DCDC
 - Deep sleep with external wakeup (without SRAM retention): 0.7 μ A
 - Deep sleep with SRAM retention: 1.7 μ A (with 32 KB SRAM retention), 2.7 μ A (with 64 KB SRAM retention), 4.7 μ A (with 96 KB SRAM retention)
 - Deep sleep with external wakeup (without SRAM retention, with 32K RC): 1.1 μ A

- Deep sleep with SRAM retention: 2.1 μ A (with 32 KB SRAM retention, with 32K RC), 3.1 μ A (with 64 KB SRAM retention, with 32K RC), 5.1 μ A (with 96 KB SRAM retention, with 32K RC)
6. Dynamic power reduction (DPR) for best energy efficiency
 7. Supports VBAT communication: Data transfer through VBAT supply modulation for easy communication with TWS charging case

1.2.5 Flash Features

The TLSR9528B embeds flash with features below:

1. Puya P25Q16SU
1. Total 1621MB (128168 Mbits)
2. Flexible architecture: 4 KB per sector, 64 KB / 32 KB per block
3. Up to 256 bytes per programmable page
4. Write protect all or portions of memory
5. Sector erase (4 KB)
6. Block erase (32 KB / 64 KB)
7. Cycle endurance: 100,000 program/erases
8. Data retention: typical 20-year retention

1.2.6 Bluetooth Features

Bluetooth features include:

1. Qualified Bluetooth BR, EDR, and Bluetooth LE 5.3, main features include:
 - 1Mbps, 2Mbps, Long Range S2 (500 Kbps), S8 (125 Kbps)
 - High duty cycle non-connectable ADV
 - Extended ADV
 - LE channel selection algorithm #2
2. Bluetooth SIG Mesh support
3. Bluetooth based location and indoor positioning support with AoA and AoD (a.k.a Bluetooth 5.3)
4. Bluetooth ISO channel support (a.k.a Bluetooth 5.3) with broadcast and connected mode
5. TWS audio over either Bluetooth Classic or Bluetooth LE 5.3 channels

1.2.7 Zigbee Features

Zigbee features include:

1. Zigbee 3.0 platform with Zigbee 3.0 device support, compatible with ZHA and ZLL
2. Green Power support for low power devices
3. Supports High Data Rate Modes (500/1000/2000 kbps) for applications beyond IEEE 802.15.4 compliant networks
4. Supports Automatic Rate Recognition feature based on SFD field

1.2.8 OpenThread Features

OpenThread features include:

1. Implement all Thread networking layers (IPv6, 6LoWPAN, IEEE 802.15.4 with MAC security, Mesh Link Establishment, Mesh Routing)
2. Supports Full Thread Device (FTD) and Minimal Thread Device (MTD)
3. Supports rich applications
 - IPv6 configuration and raw data interface
 - UDP sockets
 - CoAP client and server

1.2.9 HomeKit Features

HomeKit features include:

1. Single-chip solution with hardware acceleration for all HomeKit security operations
2. Supports Apple HomeKit ADK over Bluetooth LE and Thread
3. Conformant to latest HomeKit specification
4. Tested against Apple HomeKit Accessory Tester and Apple iOS HomeKit HOME application
5. Supports all HAP defined services and characteristics
6. Supports custom defined HAP services and characteristics
7. HomeKit custom update over-the-air (OTA) profile for secure software upgrade over the air implemented

1.2.10 Wireless Audio Features

Wireless audio features include:

1. High performance stereo audio codec with SNR over 96 dB and sample rate up to 48 kHz
1. 24-bit ADC/DAC for codec
1. Telink-patented technology for true wireless stereo and 1+N hearable devices with synchronized playback and balanced power on all devices
2. Supports audio codecs such as SBC, Opus, LC3, AAC
3. Supports voice codecs such as G.711, A-Law, u-Law, CVSD, mSBC
4. Supports latest HFP, HSP, A2DP, AVRCP, SPP, and PBAP, ANCS, DIS
5. Supports Apple iAP2
6. Supports Bluetooth EDR + Bluetooth LE dual mode operation
7. Supports noise suppression and echo cancellation
8. Supports Packet Loss Concealment (PLC) for voice processing
9. Supports Voice Activity Detection (VAD)
10. Supports Keyword Spotting (KWS) and command word local recognition

1.2.11 Concurrent Mode Feature

In concurrent mode, the chip supports multiple standards working concurrently.

Typical combination is Bluetooth LE + 802.15.4 based standard (e.g. Zigbee, Thread, or 6LoWPAN): Bluetooth LE and 802.15.4 based stacks can run concurrently with one application state based on time division technology, e.g. Bluetooth LE stack and Thread stack will run alternately during the divided time slots.

1.3 Typical Applications

The TLSR9528 is an ideal SoC for advanced wireless audio solutions. Its typical applications include, but are not limited to the following:

- Wearable devices
 - Augmented reality glasses
 - Smart watches
 - Smart trackers
 - Wristband
- Audio solutions
 - Wireless headsets
 - Earbuds
- IoT applications
 - Smart lighting, smart home devices
 - RF and IR remote control
 - Smart grid
 - Intelligent logistics/transportation/city
 - Health care

1.4 Ordering Information

Table 1-1 Ordering Information of TLSR9528

Product Series	Ordering No.	Package Type	SRAM Size	Flash Size	Temperature Range	Packing Method	Minimum Order Quantity
TLSR9528	TLSR9528AER	QFN88 10x10x0.75mm 3.3V GPIO	512KB	External flash	-40°C~+85°C	TR ^a	2500
TLSR9528	TLSR9528BER	BGA104 6x4.4x0.96	512KB	2MB	-40°C~+85°C	TR	3000
TLSR9528	TLSR9528TER	QFN88 10x10x0.75mm 1.8V GPIO	512KB	External flash	-40°C~+85°C	TR	2500

a. Packing method "TR" means tape and reel. The tape and reel material DO NOT support baking under high temperature.

1.5 Package

Package dimensions of TLSR9528A and TLSR9528T are shown below.

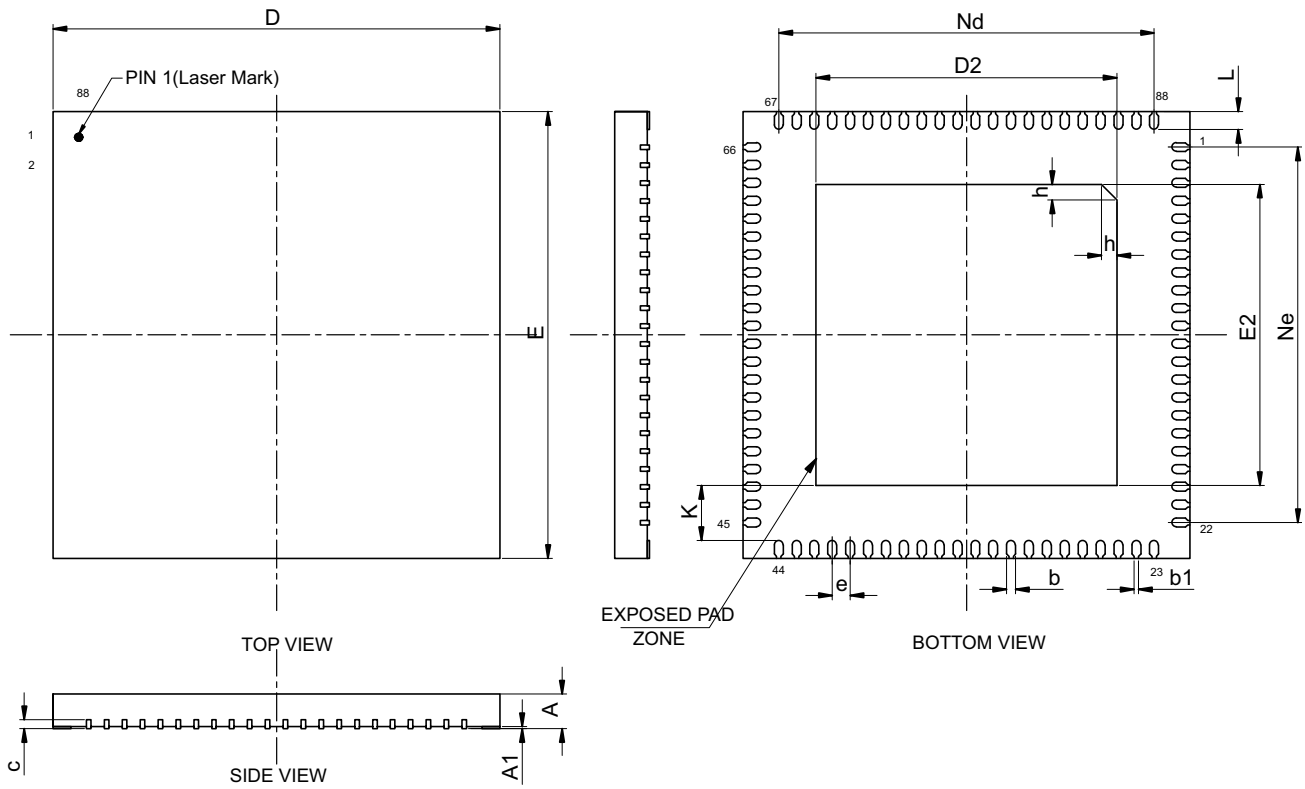
Figure 1-2 Package of TLSR9528A/T

Table 1-2 Mechanical Dimension of TLSR9528A/T

Symbol	Millimeter		
	Min	Nom	Max
A	0.7	0.75	0.80
A1	0.00	0.02	0.05
b	0.15	0.20	0.25
b1	0.10REF		
c	0.18	0.20	0.25
D	9.90	10.00	10.10
D2	6.64	6.74	6.84
e	0.40BSC		
Nd	8.40REF		
E	9.90	10.00	10.10
E2	6.64	6.74	6.84
Ne	8.40REF		

Symbol	Millimeter		
	Min	Nom	Max
L	0.30	0.40	0.50
K	0.20	-	-
h	0.30	0.35	0.40
L/F carrier	300x300		

Package dimensions of TLSR9528B are shown below.

Figure 1-3 Package of TLSR9528B

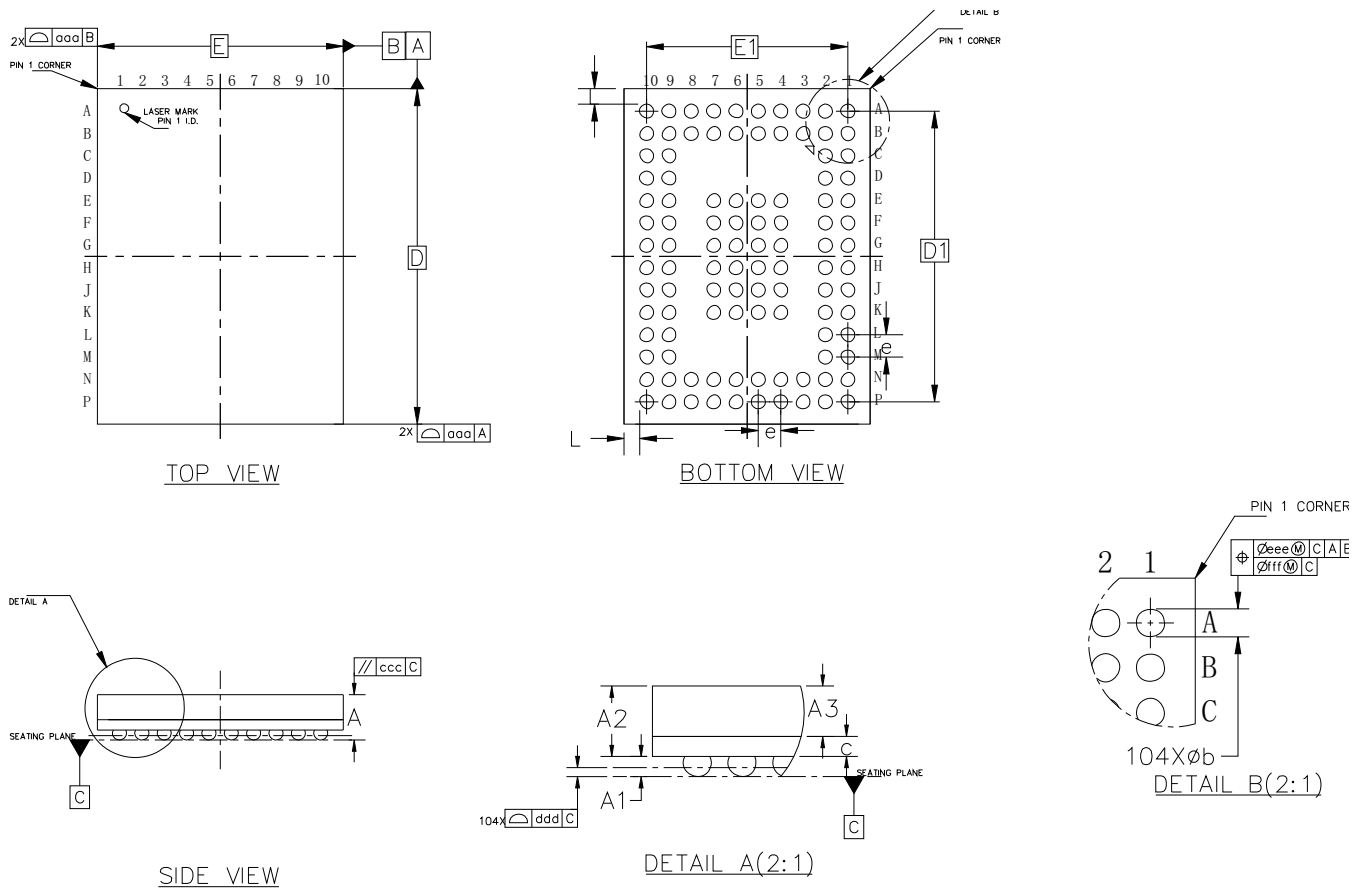

Table 1-3 Mechanical Dimension of TLSR9528B

Symbol	Millimeter		
	Min	Nom	Max
A	0.90	0.96	1.02
A1	0.13	0.18	0.23
A2	0.73	0.78	0.83

Symbol	Millimeter		
	Min	Nom	Max
A3	0.60 BASIC		
c	0.15	0.18	0.21
D	5.90	6.00	6.10
D1	5.20 BASIC		
E	4.30	4.40	4.50
E1	3.60 BASIC		
e	0.40 BASIC		
b	0.20	0.25	0.30
L	0.275 REF		
aaa	0.10		
ccc	0.08		
ddd	0.08		
eee	0.15		
fff	0.05		

1.6 Pin Layout

Pin assignment of TLSR9528A is shown below.

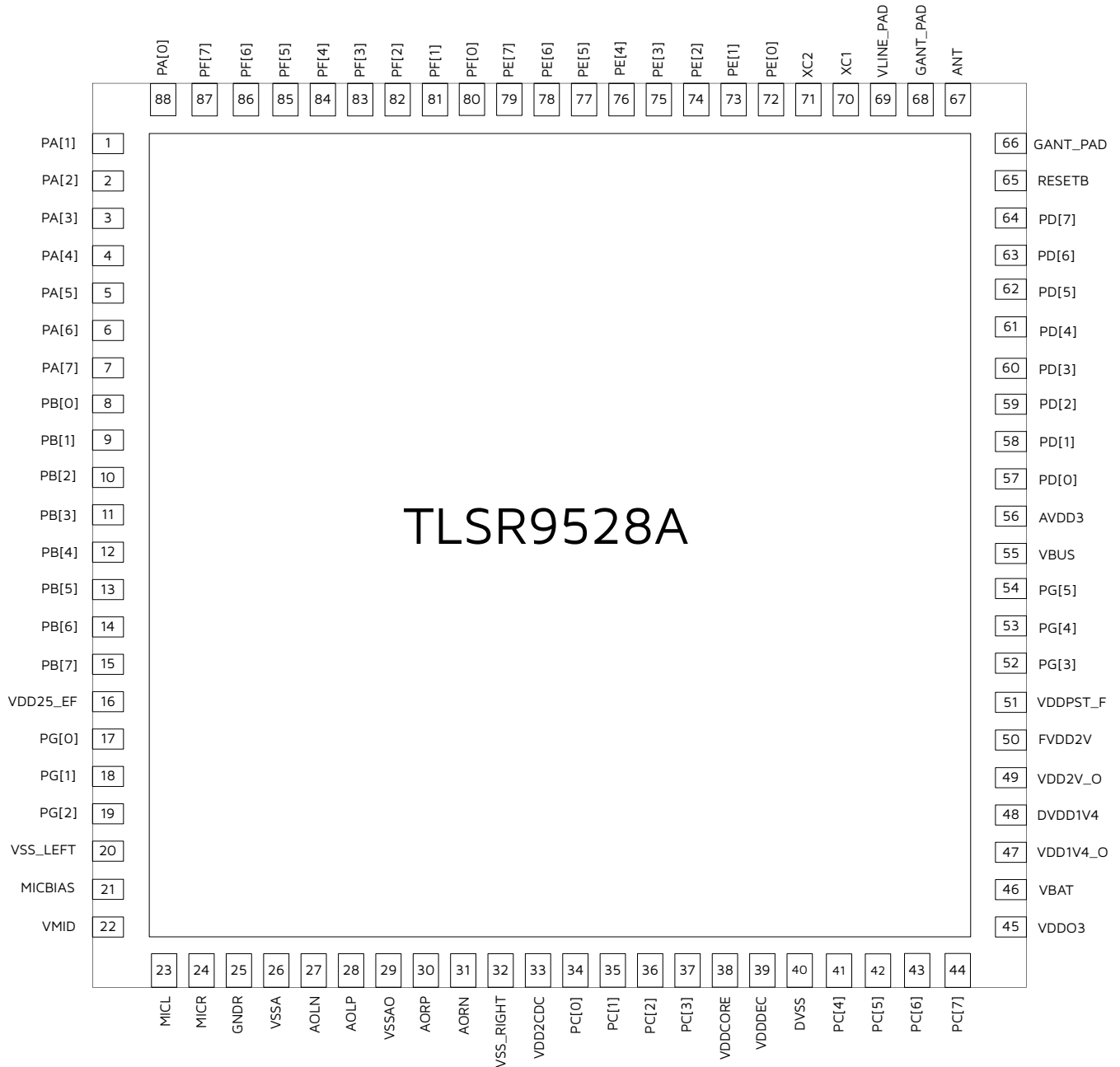
Figure 1-4 Pin Assignment of TLSR9528A

Functions of 88 pins of TLSR9528A are described in table below.

Table 1-4 Pin Function of TLSR9528A

No.	Pin Name	Type	Description
1	PA[1]	GPIO	GPIO PA[1]
2	PA[2]	GPIO	GPIO PA[2]
3	PA[3]	GPIO	GPIO PA[3]
4	PA[4]	GPIO	GPIO PA[4]

No.	Pin Name	Type	Description
5	PA[5]	GPIO	GPIO PA[5]
6	PA[6]	GPIO	GPIO PA[6]
7	PA[7]	GPIO	GPIO PA[7]
8	PB[0]	GPIO	GPIO PB[0]
9	PB[1]	GPIO	GPIO PB[1]
10	PB[2]	GPIO	GPIO PB[2]
11	PB[3]	GPIO	GPIO PB[3]
12	PB[4]	GPIO	GPIO PB[4]
13	PB[5]	GPIO	GPIO PB[5]
14	PB[6]	GPIO	GPIO PB[6]
15	PB[7]	GPIO	GPIO PB[7]
16	VDD25_EF	PWR	eFuse power supply
17	PG[0]	Flash IO	Flash IO PG[0]
18	PG[1]	Flash IO	Flash IO PG[1]
19	PG[2]	Flash IO	Flash IO PG[2]
20	VSS_LEFT	GND	Analog ground for left channel
21	MICBIAS	Analog	Microphone biasing voltage
22	VMID	Analog	Audio pin connecting to external decap
23	MICL	Analog	Left channel microphone
24	MICR	Analog	Right channel microphone
25	GNDR	GND	Analog ground
26	VSSA	GND	Analog ground
27	AOLN	Analog	Left channel negative analog output
28	AOLP	Analog	Left channel positive analog output
29	VSSAO	GND	Analog ground
30	AORP	Analog	Right channel positive analog output
31	AORN	Analog	Right channel negative analog output
32	VSS_RIGHT	GND	Analog ground for right channel

No.	Pin Name	Type	Description
33	VDD2CDC	PWR	Power supply for CODEC module
34	PC[0]	GPIO	GPIO PC[0]
35	PC[1]	GPIO	GPIO PC[1]
36	PC[2]	GPIO	GPIO PC[2]
37	PC[3]	GPIO	GPIO PC[3]
38	VDDCORE	PWR	Digital core power supply
39	VDDDEC	PWR	Digital power supply
40	DVSS	GND	Digital core ground
41	PC[4]	GPIO	GPIO PC[4]
42	PC[5]	GPIO	GPIO PC[5]
43	PC[6]	GPIO	GPIO PC[6]
44	PC[7]	GPIO	GPIO PC[7]
45	VDDO3	PWR	3.3V LDO output
46	VBAT	PWR	Lion-Battery power supply
47	VDD1V4_O	PWR	1.4V LDO/DCDC output
48	DVDD1V4	PWR	Power supply for internal digital LDO and analog LDO
49	VDD2V_O	PWR	2V LDO/DCDC output
50	FVDD2V	PWR	Flash power supply
51	VDDPST_F	PWR	Integrated flash LDO 1.8V output
52	PG[3]	Flash IO	Flash IO PG[3]
53	PG[4]	Flash IO	Flash IO PG[4]
54	PG[5]	Flash IO	Flash IO PG[5]
55	VBUS	PWR	5V USB power supply
56	AVDD3	PWR	3.3V analog power supply
57	PD[0]	GPIO	GPIO PD[0]
58	PD[1]	GPIO	GPIO PD[1]
59	PD[2]	GPIO	GPIO PD[2]
60	PD[3]	GPIO	GPIO PD[3]

No.	Pin Name	Type	Description
61	PD[4]	GPIO	GPIO PD[4]
62	PD[5]	GPIO	GPIO PD[5]
63	PD[6]	GPIO	GPIO PD[6]
64	PD[7]	GPIO	GPIO PD[7]
65	RESETB	Reset	Reset pin, active low
66	GANT_PAD	GND	Antenna ground
67	ANT	Analog	Pin to connect to the antenna through the matching network
68	GANT_PAD	GND	Antenna ground
69	VLINE_PAD	PWR	1.2V RF power supply
70	XC1	Analog	Crystal oscillator pin 1
71	XC2	Analog	Crystal oscillator pin 2
72	PE[0]	GPIO	GPIO PE[0]
73	PE[1]	GPIO	GPIO PE[1]
74	PE[2]	GPIO	GPIO PE[2]
75	PE[3]	GPIO	GPIO PE[3]
76	PE[4]	GPIO	GPIO PE[4]
77	PE[5]	GPIO	GPIO PE[5]
78	PE[6]	GPIO	GPIO PE[6]
79	PE[7]	GPIO	GPIO PE[7]
80	PF[0]	GPIO	GPIO PF[0]
81	PF[1]	GPIO	GPIO PF[1]
82	PF[2]	GPIO	GPIO PF[2]
83	PF[3]	GPIO	GPIO PF[3]
84	PF[4]	GPIO	GPIO PF[4]
85	PF[5]	GPIO	GPIO PF[5]
86	PF[6]	GPIO	GPIO PF[6]
87	PF[7]	GPIO	GPIO PF[7]
88	PA[0]	GPIO	GPIO PA[0]

Pin assignment of TLSR9528B is shown below.

Figure 1-5 Pin Assignment of TLSR9528B

	1	2	3	4	5	6	7	8	9	10																								
A	PF[4]	PF[0]	PE[6]	PE[5]	PE[0]	XC2	XC1	VLINE	GANT	ANT																								
B	PF[5]	PF[1]	PE[7]	PE[4]	PE[1]	PE[2]	PE[3]	GLINE	PD[6]	RESETB																								
C	PF[6]	PF[2]	<table border="1" style="margin: auto;"> <tr> <td>PG[0]</td> <td>VSS</td> <td>VSS</td> <td>CFG_VIO</td> </tr> <tr> <td>PG[1]</td> <td>VSS</td> <td>VSS</td> <td>AVSS</td> </tr> <tr> <td>PG[2]</td> <td>VSS</td> <td>VSS</td> <td>PG[5]</td> </tr> <tr> <td>VSSD</td> <td>VSSA_ADC</td> <td>VSS</td> <td>PG[4]</td> </tr> <tr> <td>VSSA_ANA1</td> <td>VSSA_ANA2</td> <td>VSS</td> <td>PG[3]</td> </tr> <tr> <td>VSSAO_1</td> <td>VSSAO_2</td> <td>VSS</td> <td>DVSS</td> </tr> </table>						PG[0]	VSS	VSS	CFG_VIO	PG[1]	VSS	VSS	AVSS	PG[2]	VSS	VSS	PG[5]	VSSD	VSSA_ADC	VSS	PG[4]	VSSA_ANA1	VSSA_ANA2	VSS	PG[3]	VSSAO_1	VSSAO_2	VSS	DVSS	PD[5]	PD[7]
PG[0]	VSS	VSS							CFG_VIO																									
PG[1]	VSS	VSS							AVSS																									
PG[2]	VSS	VSS							PG[5]																									
VSSD	VSSA_ADC	VSS							PG[4]																									
VSSA_ANA1	VSSA_ANA2	VSS							PG[3]																									
VSSAO_1	VSSAO_2	VSS							DVSS																									
D	PF[7]	PF[3]	PD[4]	PD[3]																														
E	PA[3]	PA[2]	PD[2]	PD[1]																														
F	PA[0]	PB[0]	PD[0]	AVDD3																														
G	PB[3]	PB[4]	VBUS	VBUS																														
H	PB[6]	PB[5]	FVDD2V	VDDPST_F																														
J	VDD25_EF	PB[7]	FVSS_DCDC	VDD2V_O																														
K	PA[1]	PA[4]	VSS_DCDC	DVDD1V4																														
L	PA[6]	PA[5]	VDD1V4_O	VBAT																														
M	MICBIAS	PA[7]	PC[6]	VBAT																														
N	VMID	PB[1]	PB[2]	PC[2]	PC[1]	PC[0]	PC[3]	VDDDEC	PC[5]	VDDO3																								
P	MICL	MICR	AOLN	AOLP	AORP	AORN	VDD2CDC	VDDCORE	PC[4]	PC[7]																								

Functions of 104 pins of TLSR9528B are described in table below.

Table 1-5 Pin Function of TLSR9528B

No.	Pin Name	Type	Description
A1	PF[4]	GPIO	GPIO PF[4]
A2	PF[0]	GPIO	GPIO PF[0]
A3	PE[6]	GPIO	GPIO PE[6]
A4	PE[5]	GPIO	GPIO PE[5]
A5	PE[0]	GPIO	GPIO PE[0]
A6	XC2	Analog	Crystal oscillator pin 2
A7	XC1	Analog	Crystal oscillator pin 1
A8	VLINE	PWR	1.2V power supply of RF transceiver
A9	GANT	GND	Ground of antenna

No.	Pin Name	Type	Description
A10	ANT	Analog	Pin to connect to the antenna through the matching network
B1	PF[5]	GPIO	GPIO PF[5]
B2	PF[1]	GPIO	GPIO PF[1]
B3	PE[7]	GPIO	GPIO PE[7]
B4	PE[4]	GPIO	GPIO PE[4]
B5	PE[1]	GPIO	GPIO PE[1]
B6	PE[2]	GPIO	GPIO PE[2]
B7	PE[3]	GPIO	GPIO PE[3]
B8	GLINE	GND	Ground of RF transceiver
B9	PD[6]	GPIO	GPIO PD[6]
B10	RESETB	Reset	Reset pin, active low
C1	PF[6]	GPIO	GPIO PF[6]
C2	PF[2]	GPIO	GPIO PF[2]
C9	PD[5]	GPIO	GPIO PD[5]
C10	PD[7]	GPIO	GPIO PD[7]
D1	PF[7]	GPIO	GPIO PF[7]
D2	PF[3]	GPIO	GPIO PF[3]
D9	PD[4]	GPIO	GPIO PD[4]
D10	PD[3]	GPIO	GPIO PD[3]
E1	PA[3]	GPIO	GPIO PA[3]
E2	PA[2]	GPIO	GPIO PA[2]
E4	PG[0]	GPIO	GPIO PG[0], not connected when using internal flash
E5	VSS	GND	GND
E6	VSS	GND	GND
E7	CFG_VIO	Analog	Configuration pin for IO voltage, connects to VSS for 3.3V IO voltage, connects to VDDO3/AVDD3 for 1.8V IO voltage.
E9	PD[2]	GPIO	GPIO PD[2]
E10	PD[1]	GPIO	GPIO PD[1]

No.	Pin Name	Type	Description
F1	PA[0]	GPIO	GPIO PA[0]
F2	PB[0]	GPIO	GPIO PB[0]
F4	PG[1]	GPIO	GPIO PG[1], not connected when using internal flash
F5	VSS	GND	GND
F6	VSS	GND	GND
F7	AVSS	GND	Analog ground
F9	PD[0]	GPIO	GPIO PD[0]
F10	AVDD3	PWR	3.3V analog power supply when CFG_VIO connects to VSS; 1.8V analog power supply when CFG_VIO connects to VDDO3/AVDD3
G1	PB[3]	GPIO	GPIO PB[3]
G2	PB[4]	GPIO	GPIO PB[4]
G4	PG[2]	GPIO	GPIO PG[2], not connected when using internal flash
G5	VSS	GND	GND
G6	VSS	GND	GND
G7	PG[5]	GPIO	GPIO PG[5], not connected when using internal flash
G9	VBUS	PWR	5V USB power supply
G10	VBUS	PWR	5V USB power supply
H1	PB[6]	GPIO	GPIO PB[6]
H2	PB[5]	GPIO	GPIO PB[5]
H4	VSSD	GND	Digital ground
H5	VSSA_ADC	GND	Analog ground for ADC
H6	VSS	GND	GND
H7	PG[4]	GPIO	GPIO PG[4], not connected when using internal flash
H9	FVDD2V	PWR	Flash power supply
H10	VDDPST_F	PWR	Integrated flash LDO 1.8V output
J1	VDD25_EF	PWR	eFuse power supply
J2	PB[7]	GPIO	GPIO PB[7]
J4	VSSA_ANA1	GND	Analog ground

No.	Pin Name	Type	Description
J5	VSSA_ANA2	GND	Analog ground
J6	VSS	GND	GND
J7	PG[3]	GPIO	GPIO PG[3], not connected when using internal flash
J9	FVSS_DCDC	GND	Ground of DCDC
J10	VDD2V_O	PWR	2V LDO/DCDC output
K1	PA[1]	GPIO	GPIO PA[1]
K2	PA[4]	GPIO	GPIO PA[4]
K4	VSSAO_1	GND	Analog ground
K5	VSSAO_2	GND	Analog ground
K6	VSS	GND	GND
K7	DVSS	GND	Digital core ground
K9	VSS_DCDC	GND	Ground of DCDC
K10	DVDD1V4	PWR	Power supply for internal digital LDO and analog LDO
L1	PA[6]	GPIO	GPIO PA[6]
L2	PA[5]	GPIO	GPIO PA[5]
L9	VDD1V4_O	PWR	1.4V LDO/DCDC output
L10	VBAT	PWR	Lion-Battery power supply
M1	MICBIAS	Analog	Microphone biasing voltage
M2	PA[7]	GPIO	GPIO PA[7]
M9	PC[6]	GPIO	GPIO PC[6]
M10	VBAT	PWR	Lion-Battery power supply
N1	VMID	Analog	Audio pin connecting to external decap
N2	PB[1]	GPIO	GPIO PB[1]
N3	PB[2]	GPIO	GPIO PB[2]
N4	PC[2]	GPIO	GPIO PC[2]
N5	PC[1]	GPIO	GPIO PC[1]
N6	PC[0]	GPIO	GPIO PC[0]
N7	PC[3]	GPIO	GPIO PC[3]

No.	Pin Name	Type	Description
N8	VDDDEC	PWR	Digital power supply
N9	PC[5]	GPIO	GPIO PC[5]
N10	VDDO3	PWR	3.3V LDO output when CFG_VIO connects to VSS; 1.8V LDO output when CFG_VIO connects to VDDO3/AVDD3
P1	MICL	Analog	Left channel microphone
P2	MICR	Analog	Right channel microphone
P3	AOLN	Analog	Left channel negative analog output
P4	AOLP	Analog	Left channel positive analog output
P5	AORP	Analog	Right channel positive analog output
P6	AORN	Analog	Right channel negative analog output
P7	VDD2CDC	PWR	Power supply for CODEC module
P8	VDDCORE	PWR	Digital core power supply
P9	PC[4]	GPIO	GPIO PC[4]
P10	PC[7]	GPIO	GPIO PC[7]

Pin assignment of TLSR9528T is shown below.

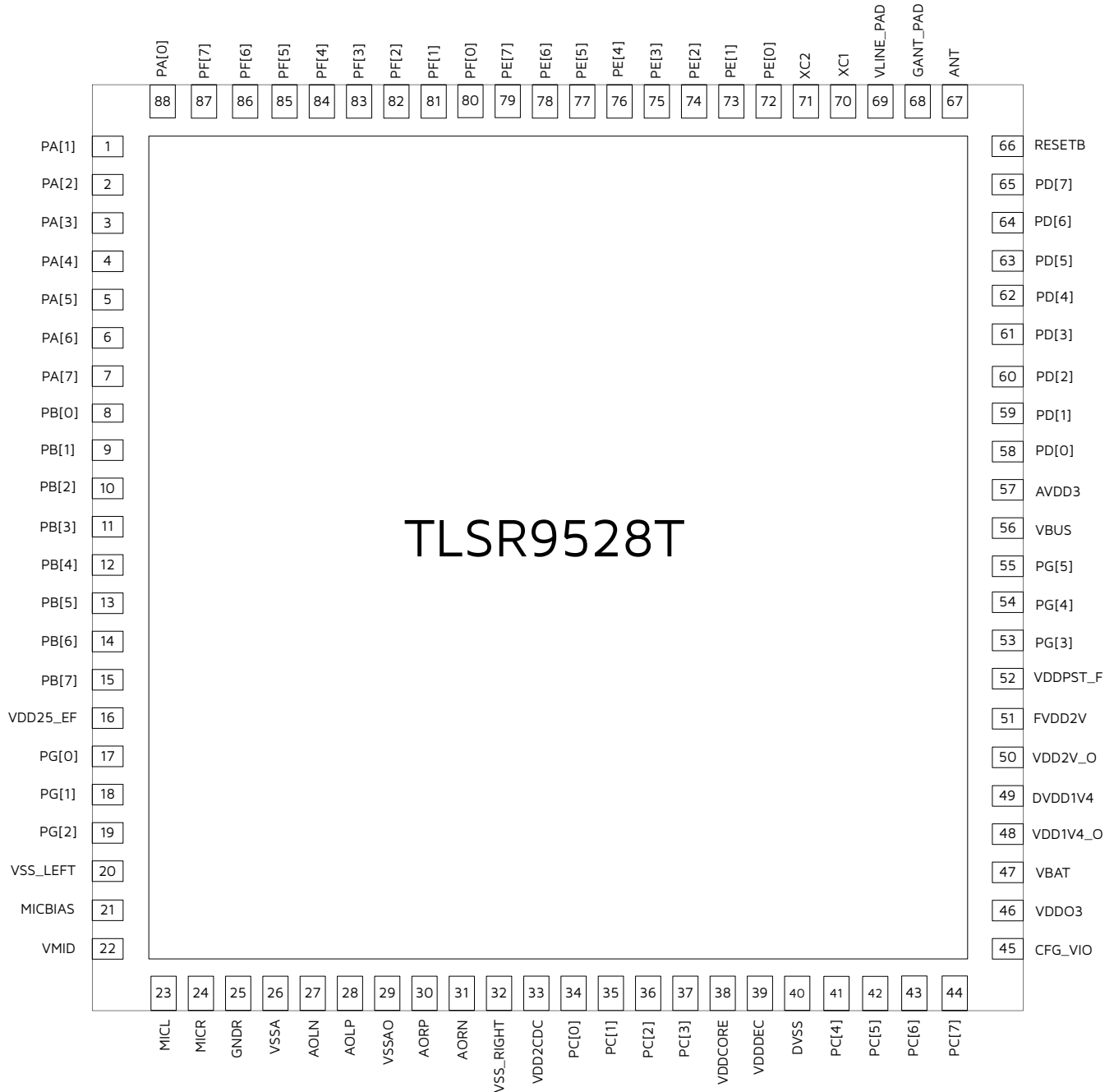
Figure 1-6 Pin Assignment of TLSR9528T

Functions of 88 pins of TLSR9528T are described in table below.

Table 1-6 Pin Function of TLSR9528T

No.	Pin Name	Type	Description
1	PA[1]	GPIO	GPIO PA[1]
2	PA[2]	GPIO	GPIO PA[2]
3	PA[3]	GPIO	GPIO PA[3]
4	PA[4]	GPIO	GPIO PA[4]

No.	Pin Name	Type	Description
5	PA[5]	GPIO	GPIO PA[5]
6	PA[6]	GPIO	GPIO PA[6]
7	PA[7]	GPIO	GPIO PA[7]
8	PB[0]	GPIO	GPIO PB[0]
9	PB[1]	GPIO	GPIO PB[1]
10	PB[2]	GPIO	GPIO PB[2]
11	PB[3]	GPIO	GPIO PB[3]
12	PB[4]	GPIO	GPIO PB[4]
13	PB[5]	GPIO	GPIO PB[5]
14	PB[6]	GPIO	GPIO PB[6]
15	PB[7]	GPIO	GPIO PB[7]
16	VDD25_EF	PWR	eFuse power supply
17	PG[0]	Flash IO	Flash IO PG[0]
18	PG[1]	Flash IO	Flash IO PG[1]
19	PG[2]	Flash IO	Flash IO PG[2]
20	VSS_LEFT	GND	Analog ground for left channel
21	MICBIAS	Analog	Microphone biasing voltage
22	VMID	Analog	Audio pin connecting to external decap
23	MICL	Analog	Left channel microphone
24	MICR	Analog	Right channel microphone
25	GNDR	GND	Analog ground
26	VSSA	GND	Analog ground
27	AOLN	Analog	Left channel negative analog output
28	AOLP	Analog	Left channel positive analog output
29	VSSAO	GND	Analog ground
30	AORP	Analog	Right channel positive analog output
31	AORN	Analog	Right channel negative analog output
32	VSS_RIGHT	GND	Analog ground for right channel

No.	Pin Name	Type	Description
33	VDD2CDC	PWR	Power supply for CODEC module
34	PC[0]	GPIO	GPIO PC[0]
35	PC[1]	GPIO	GPIO PC[1]
36	PC[2]	GPIO	GPIO PC[2]
37	PC[3]	GPIO	GPIO PC[3]
38	VDDCORE	PWR	Digital core power supply
39	VDDDEC	PWR	Digital power supply
40	DVSS	GND	Digital core ground
41	PC[4]	GPIO	GPIO PC[4]
42	PC[5]	GPIO	GPIO PC[5]
43	PC[6]	GPIO	GPIO PC[6]
44	PC[7]	GPIO	GPIO PC[7]
45	CFG_VIO	Analog	Configuration pin for IO voltage, connects to VSS for 3.3V IO voltage, connects to VDDO3/AVDD3 for 1.8V IO voltage.
46	VDDO3	PWR	3.3V LDO output when CFG_VIO connects to VSS; 1.8V LDO output when CFG_VIO connects to VDDO3/AVDD3
47	VBAT	PWR	Lion-Battery power supply
48	VDD1V4_O	PWR	1.4V LDO/DCDC output
49	DVDD1V4	PWR	Power supply for internal digital LDO and analog LDO
50	VDD2V_O	PWR	2V LDO/DCDC output
51	FVDD2V	PWR	Flash power supply
52	VDDPST_F	PWR	Integrated flash LDO 1.8V output
53	PG[3]	Flash IO	Flash IO PG[3]
54	PG[4]	Flash IO	Flash IO PG[4]
55	PG[5]	Flash IO	Flash IO PG[5]
56	VBUS	PWR	5V USB power supply
57	AVDD3	PWR	3.3V analog power supply when CFG_VIO connects to VSS; 1.8V analog power supply when CFG_VIO connects to VDDO3/AVDD3
58	PD[0]	GPIO	GPIO PD[0]

No.	Pin Name	Type	Description
59	PD[1]	GPIO	GPIO PD[1]
60	PD[2]	GPIO	GPIO PD[2]
61	PD[3]	GPIO	GPIO PD[3]
62	PD[4]	GPIO	GPIO PD[4]
63	PD[5]	GPIO	GPIO PD[5]
64	PD[6]	GPIO	GPIO PD[6]
65	PD[7]	GPIO	GPIO PD[7]
66	RESETB	Reset	Reset pin, active low
67	ANT	Analog	Pin to connect to the antenna through the matching network
68	GANT_PAD	GND	Antenna ground
69	VLINE_PAD	PWR	1.2V RF power supply
70	XC1	Analog	Crystal oscillator pin 1
71	XC2	Analog	Crystal oscillator pin 2
72	PE[0]	GPIO	GPIO PE[0]
73	PE[1]	GPIO	GPIO PE[1]
74	PE[2]	GPIO	GPIO PE[2]
75	PE[3]	GPIO	GPIO PE[3]
76	PE[4]	GPIO	GPIO PE[4]
77	PE[5]	GPIO	GPIO PE[5]
78	PE[6]	GPIO	GPIO PE[6]
79	PE[7]	GPIO	GPIO PE[7]
80	PF[0]	GPIO	GPIO PF[0]
81	PF[1]	GPIO	GPIO PF[1]
82	PF[2]	GPIO	GPIO PF[2]
83	PF[3]	GPIO	GPIO PF[3]
84	PF[4]	GPIO	GPIO PF[4]
85	PF[5]	GPIO	GPIO PF[5]
86	PF[6]	GPIO	GPIO PF[6]

No.	Pin Name	Type	Description
87	PF[7]	GPIO	GPIO PF[7]
88	PA[0]	GPIO	GPIO PA[0]

GPIO pin mux functions of TLSR9528A/B/T are shown in the table below.

Table 1-7 GPIO Pin Mux of TLSR9528

Pad	Default	Function1	Function2	Analog Function
PA[0]	GPIO	All functions ^a	SWM	-
PA[1]	GPIO	All functions	SWM	-
PA[2]	GPIO	All functions	SWM	-
PA[3]	GPIO	All functions	SWM	-
PA[4]	GPIO	All functions	SWM	-
PA[5]	GPIO	-	DM	-
PA[6]	GPIO	-	DP	-
PA[7]	SWS	-	SWS	-
PB[0]	GPIO	All functions	SWM	lp_comp<0>/sar_in<0>
PB[1]	GPIO	All functions	SWM	lp_comp<1>/sar_in<1>
PB[2]	GPIO	All functions	SWM	lp_comp<2>/sar_in<2>
PB[3]	GPIO	All functions	SWM	lp_comp<3>/sar_in<3>
PB[4]	GPIO	All functions	SWM	lp_comp<4>/sar_in<4>
PB[5]	GPIO	All functions	SWM	lp_comp<5>/sar_in<5>
PB[6]	GPIO	All functions	SWM	lp_comp<6>/sar_in<6>
PB[7]	GPIO	All functions	SWM	lp_comp<7>/sar_in<7>/ vbus_comm_rx
PC[0]	SSPI_CN	All functions	SSPI_CN	-
PC[1]	SSPI_CK	All functions	SSPI_CK	-
PC[2]	SSPI_SI	All functions	SSPI_SI	-
PC[3]	SSPI_SO	All functions	SSPI_SO	-
PC[4]	TDI	All functions	TDI	-
PC[5]	TDO	All functions	TDO	-

Pad	Default	Function1	Function2	Analog Function
PC[6]	TMS	All functions	TMS	-
PC[7]	TCK	All functions	TCK	-
PD[0]	GPIO	All functions	SWM	xtl32k_in/sar_in<8>
PD[1]	GPIO	All functions	SWM	xtl32k_out/sar_in<9>
PD[2]	GPIO	All functions	SWM	cdc_ldo_vo_test
PD[3]	GPIO	All functions	SWM	-
PD[4]	GPIO	All functions	SWM	-
PD[5]	GPIO	All functions	SWM	-
PD[6]	GPIO	All functions	SWM	-
PD[7]	GPIO	All functions	SWM	-
PE[0]	GPIO	-	LSPI_CN	-
PE[1]	GPIO	-	LSPI_CK	-
PE[2]	GPIO	-	LSPI_MOSI	-
PE[3]	GPIO	-	LSPI_MISO	-
PE[4]	GPIO	-	LSPI_IO2	-
PE[5]	GPIO	-	LSPI_IO3	-
PE[6]	GPIO	All functions	SWM	-
PE[7]	GPIO	All functions	SWM	-
PF[0]	GPIO	All functions	SWM	-
PF[1]	GPIO	All functions	SWM	-
PF[2]	GPIO	All functions	SWM	-
PF[3]	GPIO	All functions	SWM	-
PF[4]	GPIO	All functions	SWM	-
PF[5]	GPIO	All functions	SWM	-
PF[6]	GPIO	All functions special ^b	SWM	-
PF[7]	GPIO	All functions special	SWM	-

- a. "All functions" include 60 functions: GSPI_CN3, GSPI_CN2, GSPI_CN1, I2C1_SCL, I2C1_SDA, RX_CYC2LNA, ATSEL_3, ATSEL_2, ATSEL_1, ATSEL_0, BT_INBAND, BT_STATUS, BT_ACTIVITY, WIFI_DENY, TX_CYC2PA, DMIC1_DAT, DMIC1_CLK, DMICO_DAT, DMICO_CLK, I2S1_CLK, I2S1_DAT_IN, I2S1_LR_IN, I2S1_DAT_OUT, I2S1_LR_OUT, I2S1_BCK, I2SO_CLK, I2SO_DAT_IN, I2SO_LR_IN, I2SO_DAT_OUT, I2SO_LR_OUT, I2SO_BCK, CLK_7816, UART1_RTX, UART1_TX, UART1_RTS, UART1_CTS, UART0_RTX, UART0_TX, UART0_RTS, UART0_CTS, I2C_SDA, I2C_SCL, GSPI_MOSI, GSPI_MISO, GSPI_IO2, GSPI_IO3, GSPI_CK, GSPI_CNO, PWM5_N, PWM4_N, PWM3_N, PWM2_N, PWM1_N, PWMO_N, PWM5, PWM4, PWM3, PWM2, PWM1, and PWMO.
- b. "All functions special" include 55 functions, which is above 60 functions exclude GSPI_CN3, GSPI_CN2, GSPI_CN1, I2C1_SCL, and I2C1_SDA.

Flash IO multiple functions are listed in table below:

Table 1-8 Flash IO Pin Mux

Pad	Default
PG[0]	MSPI_MOSI
PG[1]	MSPI_CK
PG[2]	MSPI_IO3
PG[3]	MSPI_CN
PG[4]	MSPI_MISO
PG[5]	MSPI_IO2

NOTE:

- The default function of GPIO pins PC[5], PG[1], PG[2], PG[3] and PG[5] is outputting voltage, however, these pins cannot maintain high level or low level after deep sleep or deep retention sleep although they have pull-up/down resistor, therefore these pins are not suitable to be used for the applications that require stable voltage such as wakeup source.
- The GPIO pins PG[0...5] for MSPI interface are not suitable to be used as wakeup source.
- When the IO voltage is configured to 1.8V and the chip is powered by the 5V VBUS, the default output GPIO PC[5] will have a voltage of 3.3V for a period of time after power-on or reset. It is important to ensure that the subsequent module can tolerate a 3.3V input.

Descriptions of each signal are listed below:

NOTE: Insufficient pins will lead to lack of corresponding function including I2C, I2S, UART, DMIC, USB, JTAG, SDP and PTA.

Table 1-9 PWM Signal Description

Signal	Type	Description
PWMO	DO	PWM channel 0 output
PWMO_N	DO	PWM channel 0 inversion output

Signal	Type	Description
PWM1	DO	PWM channel 1 output
PWM1_N	DO	PWM channel 1 inversion output
PWM2	DO	PWM channel 2 output
PWM2_N	DO	PWM channel 2 inversion output
PWM3	DO	PWM channel 3 output
PWM3_N	DO	PWM channel 3 inversion output
PWM4	DO	PWM channel 4 output
PWM4_N	DO	PWM channel 4 inversion output
PWM5	DO	PWM channel 5 output
PWM5_N	DO	PWM channel 5 inversion output

Table 1-10 I2C Signal Description

Signal	Type	Description
I2C_SCL	DIO	I2C SCL
I2C_SDA	DIO	I2C SDA

Table 1-11 I2S Signal Description

Signal	Type	Description
I2S_BCK	DIO	I2S bit CLK
I2S_CLK	DO	I2S base CLK
I2S_LR_IN	DIO	I2S left and right channel SEL
I2S_LR_OUT	DIO	I2S left and right channel SEL
I2S_DAT_IN	DI	I2S data IN
I2S_DAT_OUT	DO	I2S data OUT

Table 1-12 UART Signal Description

Signal	Type	Description
UART_CTS	DI	UART Clear to Send signal
UART_RTS	DO	UART Ready to Send signal

Signal	Type	Description
UART_RTX	DIO	UART RTX
UART_TX	DO	UART TX

Table 1-13 GSPI Signal Description

Signal	Type	Description
GSPI_CLK	DIO	GSPI CLK
GSPI_CN	DIO	GSPI CN
GSPI_MISO	DIO	GSPI MISO
GSPI_MOSI	DIO	GSPI MOSI
GSPI_IO2	DIO	GSPI IO2
GSPI_IO3	DIO	GSPI IO3

Table 1-14 LSPI Signal Description

Signal	Type	Description
LSPI_CLK	DIO	LSPI CLK
LSPI_CN	DIO	LSPI CN
LSPI_MISO	DIO	LSPI MISO
LSPI_MOSI	DIO	LSPI MOSI
LSPI_IO2	DIO	LSPI IO2
LSPI_IO3	DIO	LSPI IO3

Table 1-15 SPI Slave Signal Description

Signal	Type	Description
SSPI_CLK	DI	SSPI CLK
SSPI_CN	DI	SSPI CN
SSPI_SI	DIO	SSPI SI
SSPI_SO	DIO	SSPI SO

Table 1-16 7816 Signal Description

Signal	Type	Description
CLK_7816	DO	7816 CLK

Table 1-17 DMIC Signal Description

Signal	Type	Description
DMIC_CLK	DO	DMIC CLK
DMIC_DAT	DI	DMIC DATA IN

Table 1-18 Swire Signal Description

Signal	Type	Description
SWM	DIO	Swire Master
SWS	DIO	Swire Slave

Table 1-19 External Power Amplifier, Low Noise Amplifier Signal Description

Signal	Type	Description
RX_CYC2LNA	DO	External low noise amplifier
TX_CYC2PA	DO	External power amplifier

Table 1-20 USB Signal Description

Signal	Type	Description
DP	DIO	USB DP
DM	DIO	USB DM

Table 1-21 JTAG Signal Description

Signal	Type	Description
TDI	DI	Test data input
TDO	DO	Test data output
TMS	DIO	Test mode selection
TCK	DI	Test clock input

Table 1-22 SDP Signal Description

Signal	Type	Description
TCK	DI	Test clock input
TMS	DIO	Test mode selection

Table 1-23 PTA Signal Description

Signal	Type	Description
BT_ACTIVITY	DIO	Bluetooth activity
BT_STATUS	DIO	Bluetooth status
BT_INBAND	DIO	Bluetooth inband
WIFI_DENY	DI	WIFI deny

Table 1-24 ATSEL Signal Description

Signal	Type	Description
ATSEL_3	DIO	AoA/AoD antenna selection 3
ATSEL_2	DIO	AoA/AoD antenna selection 2
ATSEL_1	DIO	AoA/AoD antenna selection 1
ATSEL_0	DIO	AoA/AoD antenna selection 0

Table 1-25 Low Current Comparator Signal Description

Signal	Type	Description
lc_comp<0>	AI	Low current comparator channel 0
lc_comp<1>	AI	Low current comparator channel 1
lc_comp<2>	AI	Low current comparator channel 2
lc_comp<3>	AI	Low current comparator channel 3
lc_comp<4>	AI	Low current comparator channel 4
lc_comp<5>	AI	Low current comparator channel 5
lc_comp<6>	AI	Low current comparator channel 6
lc_comp<7>	AI	Low current comparator channel 7

Table 1-26 SAR ADC Signal Description

Signal	Type	Description
sar_in<0>	AI	SAR ADC input channel 0
sar_in<1>	AI	SAR ADC input channel 1
sar_in<2>	AI	SAR ADC input channel 2
sar_in<3>	AI	SAR ADC input channel 3
sar_in<4>	AI	SAR ADC input channel 4
sar_in<5>	AI	SAR ADC input channel 5
sar_in<6>	AI	SAR ADC input channel 6
sar_in<7>	AI	SAR ADC input channel 7
sar_in<8>	AI	SAR ADC input channel 8
sar_in<9>	AI	SAR ADC input channel 9

Table 1-27 Crystal Signal Description

Signal	Type	Description
xtl32k_out	AO	32kHz crystal output pin
xtl32k_in	AI	32kHz crystal input pin

NOTE:

- DI: Digital input
- DO: Digital output
- DIO: Digital input/output
- AI: Analog input
- AO: Analog output
- AIO: Analog input/output

2 Electrical Specifications

NOTE: The electrical characteristics currently listed in this section are target specifications and only provided for reference. Some data may be updated according to actual test results.

2.1 Absolute Maximum Rating

Table 2-1 Absolute Maximum Rating

Characteristics	Sym.	Min.	Max.	Unit	Test Condition
Supply voltage	VBAT	-0.3	4.3	V	-
USB voltage	VBUS	-0.3	5.5	V	-
Voltage on input pin	V_{in}	-0.3	VDD+0.3	V	-
Output voltage	V_{out}	0	VDD	V	-
Storage temperature range	T_{Str}	-65	150	°C	-
Soldering temperature	T_{Sld}	-	260	°C	-

NOTE:

- Stresses above those listed in “Absolute Maximum Ratings” may cause permanent damage to the device. This is a stress only rating and operation of the device at these or any other conditions above those indicated in the operational sections of this specification is not implied.
- VDD stands for IO voltage, such as VDDO3. Generally, the range of the IO voltage is 1.8 V ~ 3.6 V, and the typical value is 3.3 V, and can be configured to 1.8V by configuring CFG_VIO pin.

2.2 Recommended Operating Conditions

Table 2-2 Recommend Operating Conditions

Item	Sym.	Min.	Typ.	Max.	Unit	Condition
Power supply voltage	VBAT	1.9	3.7	4.3	V	-
USB supply voltage	VBUS	4.5	5.0	5.5	V	-
Supply rise time (from 1.6 V to 1.8 V)	T_R	-	-	10	ms	-
Operating temperature range	T_{Opr}	-40	-	85	°C	-

2.3 DC Characteristics

Unless otherwise stated, the general test conditions are: VDD = 4.2 V, T = 25°C.

Table 2-3 RX/TX Current and Sleep Current

Item	Sym.	Min	Typ.	Max	Unit	Conditions
RX current	I_{RX}	-	4.8	-	mA	Whole chip ^a
TX current	I_{TX}	-	4.6	-	mA	Whole chip @ 0 dBm with 4.2 V DCDC, BR/BLE mode
		-	6.0	-	mA	Whole chip @ 0 dBm with 4.2 V DCDC, EDR mode
Deep sleep with 32 KB SRAM retention	I_{Deep1}	-	1.7	-	μ A	Without 32K RC ^b
Deep sleep with 64 KB SRAM retention		-	2.7	-	μ A	
Deep sleep with 96 KB SRAM retention		-	4.7	-	μ A	
Deep sleep without SRAM retention	I_{Deep2}	-	0.7	-	μ A	
Deep sleep with 32 KB SRAM retention	I_{Deep3}	-	2.1	-	μ A	With 32K RC ^c
Deep sleep with 64 KB SRAM retention		-	3.1	-	μ A	
Deep sleep with 96 KB SRAM retention		-	5.1	-	μ A	
Deep sleep without SRAM retention	I_{Deep4}	-	1.1	-	μ A	

a. The complete test conditions for TX/RX current: (1) turn off the clock and power of the modules irrelevant to RF; (2) hold the modules irrelevant to RF; (3) disable PLL clock and RC_24M to make the Pad_24M is the only clock source for cclk; (4) stall the MCU.

b. Without 32K RC: The wakeup source is external signal from GPIO input, the internal 32K RC is disabled.

c. With 32K RC: The wakeup source is 32K RC, it is enabled.

Table 2-4 Digital Inputs/Outputs

Item	Sym.	Min.	Typ.	Max.	Unit	Conditions
Input high voltage	V_{IH}	0.7*VDD	-	VDD	V	-
Input low voltage	V_{IL}	VSS	-	0.3*VDD	V	-
Output high voltage	V_{OH}	0.9*VDD	-	VDD	V	-

Item	Sym.	Min.	Typ.	Max.	Unit	Conditions
Output low voltage	VOL	VSS	-	0.1*VDD	V	-

2.4 AC Characteristics

NOTE: The data in this section is only provided for reference and will be updated according to actual test results.

2.4.1 RF Performance

Unless otherwise stated, the general test conditions are: VDD = 4.2 V, T = 25°C.

Table 2-5 RF Performance Characteristics

Item	Sym.	Min.	Typ.	Max.	Unit	Conditions	
RF frequency range	-	2400	-	2483.5	MHz	Programmable in 1 MHz step	
Data rate	BR 1 Mbps, ±160 kHz deviation EDR 2 Mbps, ±160 kHz deviation EDR 3 Mbps, ±160 kHz deviation Bluetooth LE/2.4G proprietary 1 Mbps, ±250 kHz deviation Bluetooth LE/2.4G proprietary 2 Mbps, ±500 kHz deviation Bluetooth LE 125 kbps, ±250 kHz deviation Bluetooth LE 500 kbps, ±250 kHz deviation IEEE 802.15.4 250 kbps, ±500 kHz deviation 2.4GHz proprietary 250 kbps, ±62.5 kHz deviation 2.4GHz proprietary 500 kbps, ±125 kHz deviation						
BT BR RF_RX Performance							
Sensitivity	1 Mbps	-	-	-92	-	dBm	-
Frequency offset tolerance	-	-200	-	+200	-	kHz	-
Maximum received signal at 0.1% BER	-	-	0	-	-	dBm	-
Co-channel rejection	-	-	11	-	-	dB	Wanted signal at -60 dBm

Item		Sym.	Min.	Typ.	Max.	Unit	Conditions
In-band blocking rejection (equal modulation interference)	+1/-1 MHz offset	-	-	-8/-8	-	dB	Wanted signal at -60 dBm
	+2/-2 MHz offset	-	-	-35/-35	-	dB	Wanted signal at -60 dBm
	+3/-3 MHz offset	-	-	-55/-55	-	dB	Wanted signal at -67 dBm
Image rejection		-	-	-35	-	dB	Wanted signal at -60 dBm; image frequency = RF_channel - 2 MHz
BT BR RF_TX Performance							
Output power, maximum setting		-	-	10	-	dBm	-
Transmitter power control step		-	-	3	-	dB	-
Output power control range		-	-	30	-	dB	-
Initial carrier frequency offset		-	-	±10	-	kHz	-
Frequency drift (DH3)		-	-	±10	-	kHz	-
Frequency deviation	Δf_{1avg}	-	-	160	-	kHz	140 kHz ~ 175 kHz
	Δf_{2max}	-	115	-	-	kHz	≥ 115 kHz
	$\Delta f_{2avg} / \Delta f_{1avg}$	-	-	0.9	-	-	≥ 0.8
Adjacent channel power (ACP)	M - N = 2	-	-	-	-20	dBm	-
	M - N = 3	-	-	-	-40	dBm	-
Modulation 20 dB bandwidth		-	-	0.9	-	MHz	-
BT EDR RF_RX Performance							

Item		Sym.	Min.	Typ.	Max.	Unit	Conditions
Sensitivity	EDR2 2 Mbps	-	-	-93	-	dBm	-
	EDR3 3 Mbps	-	-	-86.5	-	dBm	-
Frequency offset tolerance		-	-200	-	+200	kHz	-
Maximum received signal at 0.1% BER		-	-	0	-	dBm	-
EDR2	Co-channel rejection	-	-	10	-	dB	Wanted signal at -60 dBm
	In-band blocking rejection (equal modulation interference)	+1/-1 MHz offset	-	-12/-13	-	dB	Wanted signal at -60 dBm
		+2/-2 MHz offset	-	-48/-48	-	dB	Wanted signal at -60 dBm
		+3/-3 MHz offset	-	-51/-52	-	dB	Wanted signal at -67 dBm
	Image rejection	-	-	-33	-	dB	Wanted signal at -67 dBm; image frequency = RF_channel - 2 MHz
EDR3	Co-channel rejection	-	-	16	-	dB	Wanted signal at -60 dBm
	In-band blocking rejection (equal modulation interference)	+1/-1 MHz offset	-	-7/-7	-	dB	Wanted signal at -60 dBm
		+2/-2 MHz offset	-	-33/-33	-	dB	Wanted signal at -60 dBm
		+3/-3 MHz offset	-	-51/-50	-	dB	Wanted signal at -67 dBm
	Image rejection	-	-	-33	-	dB	Wanted signal at -67 dBm; image frequency = RF_channel - 2 MHz
BT EDR RF_TX Performance							
Output power, maximum setting		-	-	7	-	dBm	-

Item		Sym.	Min.	Typ.	Max.	Unit	Conditions
Transmitter power control step		-	-	3	-	dB	-
Output power control range		-	30			dB	-
Initial carrier frequency offset		-	-	±10	-	kHz	-
Frequency drift	EDR2 (2DH5)	-	-	±10	-	kHz	-
	EDR3 (3DH5)	-	-	±10	-	kHz	-
Adjacent channel power (ACP)	EDR2	M - N = 2	-	-	-20	dBm	-
		M - N = 3	-	-	-40	dBm	-
	EDR3	M - N = 2	-	-	-20	dBm	-
		M - N = 3	-	-	-40	dBm	-
Modulation accuracy	EDR2	RMS DEVM	-	8	-	%	≤ 20%
		PEAK DEVM	-	20	-	%	≤ 30%
		99% DEVM	-	-	35	%	≤ 35%
	EDR3	RMS DEVM	-	8	-	%	≤ 13%
		PEAK DEVM	-	20	-	%	≤ 25%
		99% DEVM	-	-	20	%	≤ 20%
Modulation 20 dB bandwidth		-	-	0.9	-	MHz	-
Bluetooth LE 1 Mbps RF_RX Performance (±250 kHz Deviation)							
Sensitivity	1 Mbps	-	-	-96	-	dBm	-
Frequency offset tolerance		-	-200	-	+200	kHz	-
Co-channel rejection		-	-	8	-	dB	Wanted signal at -67 dBm

Item		Sym.	Min.	Typ.	Max.	Unit	Conditions
In-band blocking rejection (equal modulation interference)	+1/-1 MHz offset	-	-	-4/-3	-	dB	Wanted signal at -67 dBm
	+2/-2 MHz offset	-	-	-41/-41	-	dB	
	≥ 3 MHz offset	-	-	-49	-	dB	
Image rejection		-	-	-38	-	dB	Wanted signal at -67 dBm; image frequency = RF_channel - 2MHz
Bluetooth LE 1 Mbps RF_TX Performance							
Output power, maximum setting		-	-	10	-	dBm	-
Output power, minimum setting		-	-	-24	-	dBm	-
Programmable output power range		-	34			dB	-
Modulation 20 dB bandwidth		-	-	1.4	-	MHz	-
Bluetooth LE 2 Mbps RF_RX Performance (±500 kHz Deviation)							
Sensitivity	2 Mbps	-	-	-93.5	-	dBm	-
Frequency offset tolerance		-	-300	-	+300	kHz	-
Co-channel rejection		-	-	8	-	dB	Wanted signal at -67 dBm
In-band blocking rejection	+2/-2 MHz offset	-	-	-4/-4	-	dB	Wanted signal at -67 dBm
	+4/-4 MHz offset	-	-	-35/-35	-	dB	
	> 6 MHz offset	-	-	-39	-	dB	
Image rejection		-	-	-25	-	dB	Wanted signal at -67 dBm; image frequency = RF_channel - 3 MHz

Item	Sym.	Min.	Typ.	Max.	Unit	Conditions	
Bluetooth LE 2 Mbps RF_TX Performance							
Output power, maximum setting	-	-	10	-	dBm	-	
Output power, minimum setting	-	-	-24	-	dBm	-	
Programmable output power range			34		dB	-	
Modulation 20 dB bandwidth	-	-	2.5	-	MHz	-	
Bluetooth LE 125 kbps RF_RX Performance (± 250kHz Deviation)							
Sensitivity	125 kbps	-	-	-100.5	-	dBm	-
Frequency offset tolerance		-	-200	-	+200	kHz	-
Co-channel rejection		-	-	2	-	dB	Wanted signal at -79 dBm
In-band blocking rejection (equal modulation interference)	+1/-1 MHz offset	-	-	-6/-6	-	dB	Wanted signal at -79 dBm
	+2/-2 MHz offset	-	-	-38/-38	-	dB	
	≥ 3 MHz offset	-	-	-48/-48	-	dB	
Image rejection		-	-	-27	-	dB	Wanted signal at -79 dBm; image frequency = RF_channel - 2 MHz
Bluetooth LE 125 kbps RF_TX Performance							
Output power, maximum setting	-	-	10	-	dBm	-	
Output power, minimum setting (resolution)	-	-	-24	-	dBm	-	
Programmable output power range	-		34		dB	-	
Modulation 20 dB bandwidth	-	-	1.4	-	MHz	-	

Item		Sym.	Min.	Typ.	Max.	Unit	Conditions
Bluetooth LE 500 kbps RF_RX Performance (± 250 kHz Deviation)							
Sensitivity	500 kbps	-	-	-98.5	-	dBm	-
Frequency offset tolerance		-	-200	-	+200	kHz	-
Co-channel rejection		-	-	4	-	dB	Wanted signal at -72 dBm
In-band blocking rejection (equal modulation interference)	+1/-1 MHz offset	-	-	-6/-6	-	dB	Wanted signal at -72 dBm
	+2/-2 MHz offset	-	-	-42/-41	-	dB	
	≥ 3 MHz offset	-	-	-55	-	dB	
Image rejection		-	-	-40	-	dB	Wanted signal at -72 dBm; image frequency = RF_channel - 2 MHz
Bluetooth LE 500 kbps RF_TX Performance							
Output power, maximum setting		-	-	10	-	dBm	-
Output power, minimum setting		-	-	-24	-	dBm	-
Programmable output power range		-	34			dB	-
Modulation 20 dB bandwidth		-	-	1.4	-	MHz	-
Zigbee/Rf4CE/6LoWPan/Thread RF_RX Performance (IEEE 802.15.4 250 kbps ± 500 kHz Deviation)							
Sensitivity	250 kbps	-	-	-99.5	-	dBm	-
Frequency offset tolerance		-	-300	-	+300	kHz	-
Adjacent channel rejection (-1/+1 channel)		-	-	-38/-38	-	dB	Wanted signal at -82 dBm
Adjacent channel rejection (-2/+2 channel)		-	-	-38/-38	-	dB	Wanted signal at -82 dBm
Zigbee/Rf4CE/6LoWPan/Thread RF_TX Performance (IEEE 802.15.4 250 kbps)							

Item	Sym.	Min.	Typ.	Max.	Unit	Conditions
Output power, maximum setting	-	-	10	-	dBm	-
Output power, minimum setting (resolution)	-	-	-24	-	dBm	-
Programmable output power range	-	34			dB	-
Modulation 20 dB bandwidth	-	-	2.7	-	MHz	-
Error vector magnitude	EVM	-	-	2%	-	Max (10 dBm) power output

Table 2-6 USB Characteristics

Item	Sym.	Min.	Typ.	Max.	Unit	Conditions
USB output signal cross-over voltage	V_{CrS}	1.3	-	2.0	V	-

Table 2-7 RSSI Characteristics

Item	Sym.	Min.	Typ.	Max.	Unit	Conditions
RSSI range	-	-100	-	0	dBm	-
Resolution	-	-	±1	-	dB	-

Table 2-8 Crystal Characteristics

Item	Sym.	Min.	Typ.	Max.	Unit	Conditions
24 MHz Crystal						
Nominal frequency (parallel resonant)	f_{NOM}	-	24	-	MHz	-
Frequency tolerance	f_{TOL}	-20	-	+20	ppm	-
Load capacitance	C_L	5	12	18	pF	Programmable on chip load cap
Equivalent series resistance	ESR	-	50	100	Ohm	-
32.768 kHz Crystal						

Item	Sym.	Min.	Typ.	Max.	Unit	Conditions
Nominal frequency (parallel resonant)	f_{NOM}	-	32.768	-	kHz	-
Frequency tolerance	f_{TOL}	-100	-	+100	ppm	-
Load capacitance	C_L	6	9	12.5	pF	Programmable on chip load cap
Equivalent series resistance	ESR	-	50	80	kOhm	-

Table 2-9 RC Oscillator Characteristics

Item	Sym.	Min.	Typ.	Max.	Unit	Conditions
24 MHz RC Oscillator						
Nominal frequency	f_{NOM}	-	24	-	MHz	-
Frequency tolerance	f_{TOL}	-	1	-	%	On chip calibration
32 kHz RC Oscillator						
Nominal frequency	f_{NOM}	-	32	-	kHz	-
Frequency tolerance	f_{TOL}	-	0.03	-	%	On chip calibration
Calibration time	-	-	3	-	ms	-

Table 2-10 ADC Characteristics

Item	Sym.	Min.	Typ.	Max.	Unit	Conditions
Differential nonlinearity	DNL	-	-	1	LSB	10-bit resolution mode
Integral nonlinearity	INL	-	-	2	LSB	10-bit resolution mode
Signal-to-noise and distortion ratio	SINAD	-	70	-	dB	$f_{\text{IN}} = 1 \text{ kHz}$, $f_{\text{S}} = 16 \text{ kHz}$
Effective number of bits	ENOB	-	10.5	-	bits	-
Sampling frequency	F_s	-	-	200	ksps	-

2.4.2 Audio Performance

2.4.2.1 Analog Input to Digital Output

Measurement conditions: Input sine wave with a frequency of 1kHz, measurement bandwidth 20Hz– $F_s / 2$ for $F_s = 8$ to 32 kHz, measurement bandwidth 20 Hz to 20 kHz for $F_s = 44.1$ kHz to 96 kHz, unless otherwise specified.

Table 2-11 Analog Microphone / Line Input to ADC Path

Parameter	Test conditions	Min.	Typ	Max.	Unit
SNR	500mVp input of 1.02 kHz, 0dB PGA gain	-	75	-	dB
THD+N	normal performance	-	-70	-	dB

2.4.2.2 Digital Input to Analog Output

Measurement conditions: input sine wave with a frequency of 1 kHz, measurement bandwidth 20 Hz to 20 kHz, unless otherwise specified.

Table 2-12 Audio DAC to Headphone Output Path

Parameter	Test conditions	Min.	Typ	Max.	Unit
Output voltage	-	1.771	1.806	1.847	V
Maximum output power	32 Ohm load	-	22.5	-	mW
	16 Ohm load	-	31	-	mW
Dynamic Range	-	-	100	-	dB
Noise	-	-	10	-	uV
THD	-6dB input @1.02kHz/6.2kHz or 5.6mW for 32ohm	-	-98	-	dB
THD+N	@12 mW	-	-84	-	dB
	@5 mW	-	-88	-	dB
Pop-up Noise	Active < - > Inactive, 10 kOhm load	-	-70	-	dBV
Output load resistance (RI)	-	16	-	32	Ohm

2.5 Storage Conditions

The SoC series is applicable to Moisture Sensitivity Level 3 (based on JEDEC Standard).

1. Calculated shelf life in sealed moisture barrier bag (MBB): 12 months at <math><40^{\circ}\text{C}</math> and <math><90\%</math> relative humidity (RH)
2. Peak package body temperature: 260°C

3. After bag is opened, devices that will be subjected to reflow solder or other high temperature process must be
 - Mounted within: 168 hours of factory conditions $\leq 30^{\circ}\text{C}/60\% \text{RH}$, or
 - Stored at $<10\% \text{RH}$
4. Devices require bake before mounting, if:
 - Humidity Indicator Card reads $>10\%$ when read at $23 \pm 5^{\circ}\text{C}$
 - Both of the conditions in 3 are not met
5. If baking is required, devices may be baked for 24 hours at $125 \pm 5^{\circ}\text{C}$

Note: If device containers cannot be subjected to high temperature or shorter bake times are desired, please refer to IPC/JEDEC J-STD-033 for bake condition.

3 Reference Design

3.1 Reference Schematic for TLSR9528A

The reference schematic of TLSR9528A is shown as below.

Figure 3-1 Reference Schematic of TLSR9528A

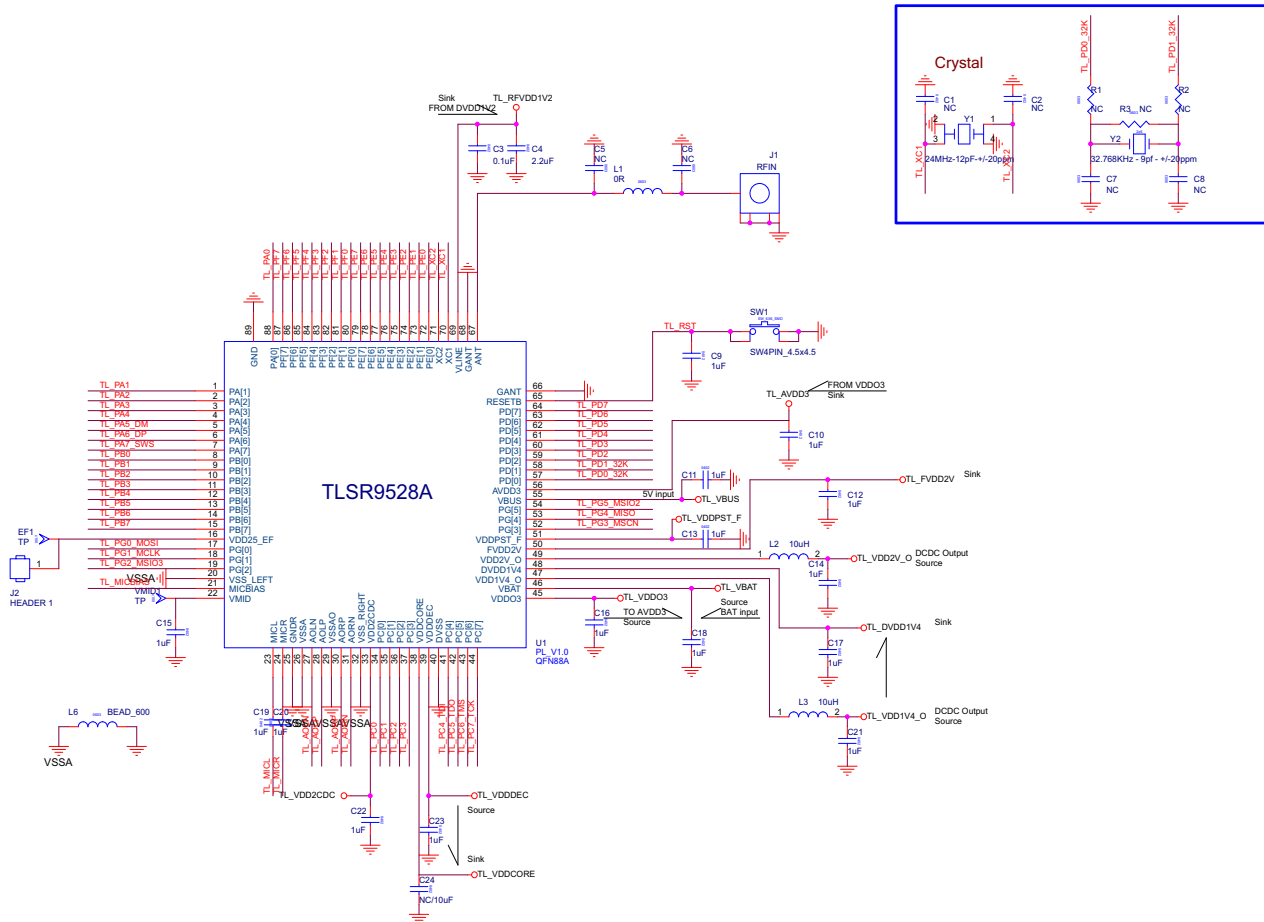

3.2 BOM (Bill of Material) for TLSR9528A

The bill of material table for TLSR9528A reference design is listed as below.

Table 3-1 BOM Table for TLSR9528A Reference Design

Quantity	Reference	Value	Description
1	C3	0.1uF	Capacitance,X5R, ±10%
15	C9,C10,C11,C12,C13,C14,C15,C16,C17, C18,C19,C20,C21,C22,C23	1uF	Capacitance,X5R, ±10%
1	C4	2.2uF	Capacitance,X5R, ±10%

Quantity	Reference	Value	Description
1	J1	RFIN	Connector for RF input
1	J2	HEADER 1	Pin headers
1	L1	OR	Resistance,SMD,±5%
2	L2,L3	10uH	High frequency chip inductor,SMD,20%
1	L6	BEAD_600	BEAD
1	SW1	SW4PIN_4.5x4.5	Button
1	U1	TLSR9528A	BT/BLE Audio SOC
1	Y1	24MHz-12pF-+/- 20ppm	XTAL SMD 3225, 24 MHz, CI=12pF, total tol.±20ppm
1	Y2	32.768KHz - 9pf - +/-20ppm	XTAL RADIAL 2x6mm, 32.768KHz, CI=9pF, total tol.±20ppm

3.3 Reference Schematic for TLSR9528B

The reference schematic of TLSR9528B is shown as below.

Quantity	Reference	Value	Description
1	J19	HEADER 3	Jumper
1	L1	OR	Resistance,SMD,±5%
2	L2,L3	10uH	High frequency chip inductor,SMD,20%
1	SW1	SW4PIN_4.5x4.5	Button
1	U1	TLSR9528B	BT/BLE Audio SOC
1	Y1	24MHz-12pF-+/-20ppm	XTAL SMD 3225, 24 MHz, CI=12pF, total tol.±20ppm
1	Y2	32.768KHz - 9pf - +/-20ppm	XTAL RADIAL 2x6mm, 32.768KHz, CI=9pF, total tol.±20ppm

3.5 Reference Schematic for TLSR9528T

The reference schematic of TLSR9528T is shown as below.

Figure 3-3 Reference Schematic of TLSR9528T

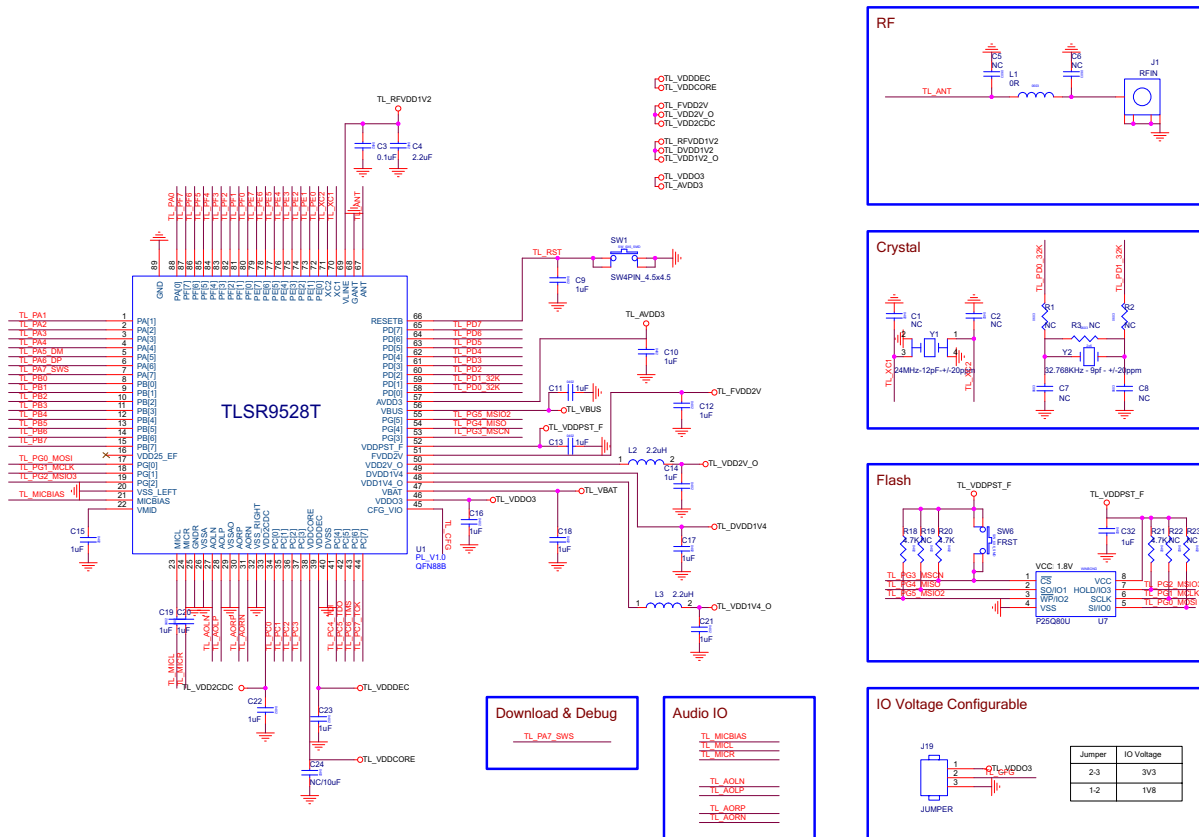

3.6 BOM (Bill of Material) for TLSR9528T

The bill of material table for TLSR9528T reference design is listed as below.

Table 3-3 BOM Table for TLSR9528T Reference Design

Quantity	Reference	Value	Description
1	C3	0.1uF	Capacitance,X5R, ±10%
16	C9,C10,C11,C12,C13,C14,C15,C16,C17, C18,C19,C20,C21,C22,C23,C32	1uF	Capacitance,X5R, ±10%
1	C4	2.2uF	Capacitance,X5R, ±10%
1	J1	RFIN	Connector for RF input
1	J19	HEADER 3	Jumper
1	L1	OR	Resistance,SMD,±5%
2	L2,L3	10uH	High frequency chip inductor,SMD,20%
3	R18,R20,R21	4.7K	Resistance,SMD,±5%
1	SW1	SW4PIN_4.5x4.5	Button
1	SW6	FRST	Button
1	U1	TLSR9528T	BT/BLE Audio SOC
1	U7	P25Q80U	Flash
1	Y1	24MHz-12pF-+/- 20ppm	XTAL SMD 3225, 24 MHz, Cl=12pF, total tol.±20ppm
1	Y2	32.768KHz - 9pf - +/-20ppm	XTAL RADIAL 2x6mm, 32.768KHz, Cl=9pF, total tol.±20ppm

4 Memory, MCU and PMU

4.1 Memory

The SoC embeds 256 KB SRAM (including 96 KB with retention in deep sleep) as instruction memory, 256 KB SRAM as data memory, and external flash (depending on detailed parts, see section [1.4](#)) as program memory.

4.1.1 SRAM

The memory map is shown below. As shown in the figure, the SoC embedded 2 SRAM, 256 KB instruction local memory (ILM) and 256 KB data local memory (DLM). For ILM, the lower 96 KB is with retention in deep sleep. ILM and DLM have different addressing address for MCPU (shown as ILM_CPU and DLM_CPU). Please be noted, ILM can store both instruction and data while DLM can only store data, so the instruction stored in local memory should be no more than 256 KB.

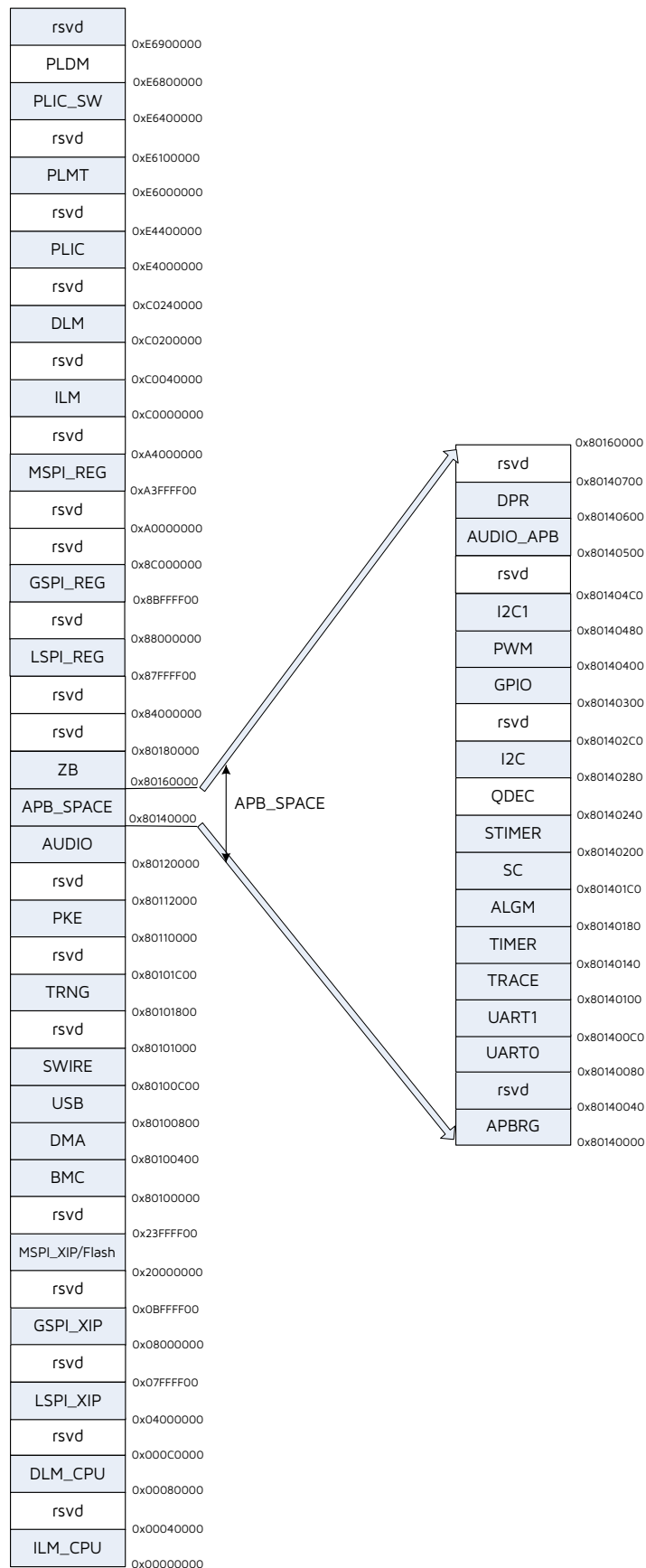
Figure 4-1 Memory Map

4.1.2 Flash

For TLSR9528A/T, the SoC does not include internal flash. Instead, a MSPI interface is provided for external flash.

The internal flash mainly supports page program, sector/block/chip erase operations, and deep power down operation. Please refer to the corresponding SDK for flash memory operation details.

Please note that the flash area ranging from 0x1FE000 to 0x1FFFFFF is reserved for Telink internal use.

MCU uses the separate MSPI_CLK frequency to load instructions, and adopts flash driver to access (read/write) flash with the same speed.

NOTE:

- By default, the page write is 256 bytes at a time and it is not recommended to write less than 255 bytes data. For example, if users want to rewrite 64 to 128 bytes in one page, the first step is to read total 256 bytes of a page, then replace the 64 to 128 bytes data, and rewrite the corrective 256 bytes to program again after page erase.

4.1.3 eFuse

The non-volatile eFuse is defined as below.

Table 4-1 eFuse Definition

Name	Default	Description
Reserved	-	Reserved for future use
MAC_ADDR	64'd0	64 bits Telink-Assigned MAC Address (including 48 bits MAC Address for Bluetooth or 64 bits MAC Address for 802.15.4)
Reserved	-	Reserved for Telink internal use
Security_Feature	32'd0	[31] Flash Encryption Enable [30] Reserved [29] mode selection, 1: secure boot mode (verified signature), 0: normal mode [28:0] Reserved for Telink internal use
pub_key_hash	256'd0	Hash public key, unmodifiable
debug_text	128'd0	Plaintext for debugging
chip_id	128'd0	128-bit chip ID, unmodifiable
Reserved	128'd0	Reserved
root_key	128'd0	Root key

Name	Default	Description
Interface functions	32'd0	[31:16] Reserved [15] if_sws_disable: SWS function disable. 1'b1: disable; 1'b0: enable. [14] if_jtag_disable: JTAG function disable. 1'b1: disable; 1'b0: enable. [13:0] Reserved

4.1.4 Unique ID

For chip identification and traceability, the SoC is preloaded with 128-bit Unique ID (UID). This UID can be read via the interface in SDK.

4.2 MCU

The SoC embeds a 32-bit RISC-V micro-controller, features are listed as following:

1. 5-stage in-order execution pipeline
2. Fast Hardware multiplier
3. Hardware divider
4. Dynamic branch prediction
 - 32-entry branch target buffer (BTB)
5. Performance monitors
6. Misaligned memory accesses
7. RISC-V RV32I base integer instruction set
8. RISC-V RVC standard extension for compressed instructions
9. RISC-V RVM standard extension for integer multiplication and division
10. RISC-V RVA standard extension for atomic instructions
11. RISC-V "F" standard extensions for single-precision floating-point
12. DSP extension
13. I & D caches
14. I & D local memories
15. Machine mode and User mode
16. 8 entries PMP (Physical Memory Protection)

4.2.1 Physical Memory Protection

To support secure processing and contain faults, it is desirable to limit the physical addresses accessible by software running on a hart (hardware thread). Physical memory protection (PMP) unit provides hart machine-mode control registers to allow physical memory access privileges (read, write, execute) to be specified for each physical memory region.

PMP checks are applied to all accesses when the hart is running in U modes, and for loads and stores when the MPRV bit is set in the m-status register and the MPP field in the m-status register contains U. Optionally, PMP checks may additionally apply to M-mode accesses, in which case the PMP registers themselves are locked, so that even M-mode software cannot change them without a system reset. PMP violations are always trapped precisely at the processor.

PMP entries are described by an 8-bit configuration register and one 32 bit address register.

8 PMP entries are supported. PMP CSRs are only accessible to M-mode.

NOTE: The abbreviations for the Type column of register table are summarized below:

- *RO: read only*
- *WO: write only*
- *R/W: readable and writable*
- *W1C: write 1 to clear*
- *W1S: write 1 to set*
- *Volatile: can be modified unexpectedly*

Table 4-2 PMP Configuration Registers

CSR Address	CSR Name	Bit	Description
0x3A0	pmpcfg0	[31:24]	PMP3CFG
		[23:16]	PMP2CFG
		[15:8]	PMP1CFG
		[7:0]	PMPOCFG
0x3A1	pmpcfg1	[31:24]	PMP7CFG
		[23:16]	PMP6CFG
		[15:8]	PMP5CFG
		[7:0]	PMP4CFG

The 8-bit PMPiCFG is described as below.

Table 4-3 PMPiCFG Description

Field Name	Bit	Description	Type	Reset
L	[7]	Write lock and permission enforcement bit for Machine mode. 0: Machine mode writes to PMP entry registers are allowed. R/W/X permissions apply to U modes 1: For PMP entry i, writes to PMPiCFG and PMPADDRi are ignored. Additionally, if PMPiCFG.A is set to TOR, writes to pmpaddr _{i-1} are ignored as well. As for Permission enforcement, R/W/X permissions apply to all modes. This bit can only be cleared to 0 with a system reset	W1S	0
Reserved	[6:5]	Reserved	-	-
A	[4:3]	Address matching mode. 0: OFF: Null region. 1: TOR: Top of range. For PMP entry 0, it matches any address A < pmpaddr0. For PMP entry i, it matches any address A such that pmpaddr _i > A >= pmpaddr _{i-1} . But the 4-byte range is not supported. 2: Reserved. 3: NAPOT: Naturally aligned power-of-2 region, >= 8 bytes. This mode makes use of the low-order bits of the associated address register to encode the size of the range. See Table 4-5 for range encoding from the value of a PMP address register.	R/W	0
X	[2]	Instruction execution control. 0: Instruction execution is not allowed. 1: Instruction execution is allowed	R/W	0
W	[1]	Write access control. 0: Write accesses are not allowed. 1: Write accesses are allowed.	R/W	0
R	[0]	Read access control. 0: Read accesses are not allowed 1: Read accesses are allowed.	R/W	0

Table 4-4 PMP Address Registers

CSR Address	CSR Name	Bit	Description	Type	Reset
0x3B0	pmpaddr0	[31:0]	PMP entry 0 address register	R/W	0

CSR Address	CSR Name	Bit	Description	Type	Reset
0x3B1	pmpaddr1	[31:0]	PMP entry 1 address register	R/W	0
0x3B2	pmpaddr2	[31:0]	PMP entry 2 address register	R/W	0
0x3B3	pmpaddr3	[31:0]	PMP entry 3 address register	R/W	0
0x3B4	pmpaddr4	[31:0]	PMP entry 4 address register	R/W	0
0x3B5	pmpaddr5	[31:0]	PMP entry 5 address register	R/W	0
0x3B6	pmpaddr6	[31:0]	PMP entry 6 address register	R/W	0
0x3B7	pmpaddr7	[31:0]	PMP entry 7 address register	R/W	0

Each PMP address register encodes bits 33–2 of a 34-bit physical address, as shown in the register format. The encoding is described in [Table 4-5](#). The “a” in the table represents one bit address, with arbitrary values.

Table 4-5 D25 NAPOT Range Encoding in PMP Address and Configuration Registers

Register Content	Match Size (Byte)
aaaa...aaa0	8 (2^3)
aaaa...aa01	16 (2^4)
aaaa...a011	32 (2^5)
.....
aa01...1111	2^{32}
a011...1111	2^{33}
0111...1111	2^{34}
1111...1111	2^{35}

4.3 Working Mode

The SoC supports six working modes, including Active, Idle, Suspend, Deep Sleep with SRAM retention, Deep Sleep without SRAM retention, and Shutdown.

- The Power Management (PM) module is always active in all working modes.
- For modules such as MCU, RF transceiver (Radio), and SRAM, the state depends on working mode, as shown below.

Table 4-6 Working Mode

Mode	Active	Idle	Suspend	Deep Sleep With SRAM Retention	Deep Sleep without SRAM Retention	Shutdown
MCU	active	stall	stall	off	off	off
Radio	available	available	off	off	off	off
USB	available	available/off	stall/off	off	off	off
Audio	available	available/off	stall/off	off	off	off
Wakeup Time to Active Mode in LDO Mode	-	0 μ s	100 μ s	Shorter than Deep sleep without retention, almost same as Suspend	1 ms	10 ms
Wakeup Time to Active Mode in DCDC Mode	-	-	-	-	-	-
Retention SRAMs (with retention in deep sleep)	full	full	full	full	off	off
Wakeup on RTC (32K Timer wakeup)	-	-	available	available	available	off
Wakeup on pin (IO wakeup)	-	-	available	available	available	off
Wakeup on interrupt	-	available	-	-	-	-
Wakeup on reset pin (RESETB)	-	available	available	available	available	on

NOTE:

- active: MCU is at working state.
- stall: In Idle and Suspend mode, MCU does not work, while its clock is still running.
- available for modules: It's selectable to be at working state, or stall/be powered down if it does not need to work.
- available/on for wakeup: Corresponding wakeup method is supported.
- off for wakeup: Corresponding wakeup method is not supported.
- full/off for SRAMs:
 - full: Full speed. In Active, Idle and Suspend mode, the three 32KB retention SRAMs are powered on and work normally (can be accessed); in Deep sleep with SRAM retention, the retention SRAMs are powered on, however, the contents of the retention SRAMs can be retained and cannot be accessed.
 - off: The retention SRAMs are powered down in Deep sleep without SRAM retention and Shutdown mode.

Analog registers (0x35 ~ 0x3c) as shown in below table are retained in deep sleep mode and can be used to store program state information across deep sleep cycles.

- Analog registers 0x3a-0x3c are non-volatile even when chip enters deep sleep or chip is reset by watchdog or software, i.e. the contents of these registers won't be changed by deep sleep or watchdog reset or chip software reset.
- Analog registers 0x35-0x39 are non-volatile in deep sleep, but will be cleared by watchdog reset or chip software reset.
- After POR (Power-On-Reset), all registers will be cleared to their default values, including these analog registers.

User can set flag in these analog registers correspondingly, so as to check the booting source by reading the flag.

Table 4-7 Retention Analog Registers in Deep Sleep

Address	Type	Description	Reset Value
afe_0x35	R/W	buffer clean at watchdog	11111111
afe_0x36	R/W	buffer clean at watchdog	00000000
afe_0x37	R/W	buffer clean at watchdog	00000000
afe_0x38	R/W	buffer clean at watchdog	00000000
afe_0x39	R/W	buffer clean at watchdog	00000000
afe_0x3a	R/W	buffer clean at power on	00000000
afe_0x3b	R/W	buffer clean at power on	00000000
afe_0x3c	R/W	buffer clean at power on	11111111

4.4 Reset

The chip supports three types of reset methods, including POR (Power-On-Reset), watchdog reset and software reset.

1. POR: After power on, the whole chip will be reset, and all registers will be cleared to their default values.
2. Watchdog reset: A programmable watchdog is supported to monitor the system. If watchdog reset is triggered, registers except for the retention analog registers 0x3a-0x3c will be cleared.
3. Software reset: It is also feasible to carry out software reset for the whole chip or some modules.
 - Setting address 0x2f[5] as 1'b1 is to reset the whole chip. Similar to watchdog reset, the retention analog registers 0x3a-0x3c are non-volatile, while other registers including 0x35-0x39 will be cleared by chip software reset.
 - Addresses 0x20-0x23 serve to reset individual modules: if some bit is set to logic "1", the corresponding module is reset.

The base address of the following reset related registers is 0x801401c0.

Table 4-8 Register Configuration for Software Reset

Address Offset	Name	Type	Description	Reset Value
0x20	RST0	R/W	[0]: LSPI, reset active low, 0 for reset, 1 for disable reset [1]: I2C [2]: UART0 [3]: USB [4]: PWM [5]: rsvd [6]: UART1 [7]: Swires	0xa0
0x21	RST1	R/W	[0]: rsvd [1]: System Timer [2]: DMA [3]: ALGM [4]: PKE [5]: rsvd [6]: GSPI, apb spi [7]: SPISLV, spi slave	0x80
0x22	RST2	R/W	[0]: Timer [1]: Audio [2]: I2C1 [3]: MCU reset disable [4]: MCU reset enable, when this bit set 1, enable power on reset to reset mcu (reset all) [5]: LM [6]: TRNG [7]: DPR	0x38

Address Offset	Name	Type	Description	Reset Value
0x23	RST3	R/W	[0]: ZB [1]: ZB_MSTCLK [2]: ZB_LPCLK [3]: ZB_CRYPT [4]: MSPI [5]: QDEC [6]: SARADC [7]: ALG, analog module reset	0x90
0x2f	PWDNEN	R/W	[0]: suspend enable (RW) [4]: ramcrc_clren_tgl (W) [5]: rst_all (act as watchdog reset) (VOLATILE) [7]: stall_en_trg (stall mcu trig) (W)	0x00

4.5 Power Management

The multiple-stage Power Management (PM) module is flexible to control power state of the whole chip or individual functional blocks such as MCU, RF Transceiver, and peripherals by the following methods:

1. Power-On-Reset (POR) and Brown-out detect
2. Working Mode Switch
3. LDO and DCDC
4. VBAT and VANT Power-Supply Mode

4.5.1 Power-on-Reset (POR) and Brown-out Detect

Figure below shows the control logic of power up/down.

Figure 4-2 Control Logic of Power up/down

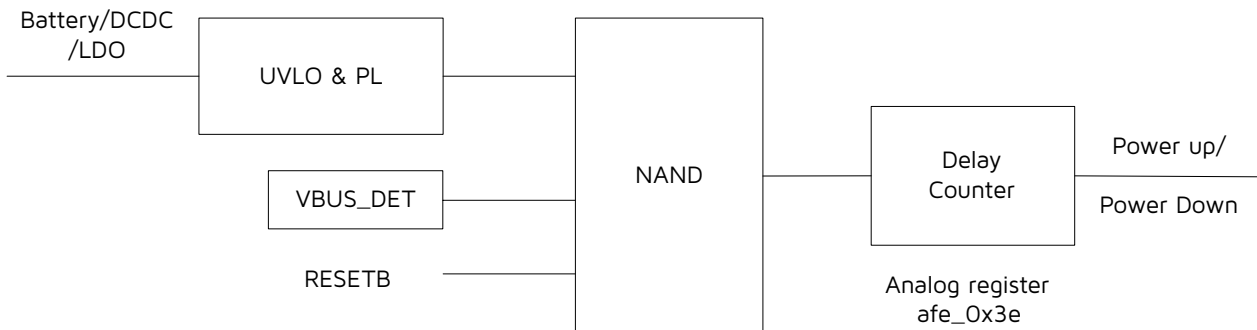

As shown in figure above, the whole power up and down is controlled by the UVLO (Ultra-low Voltage Lockout) & PL (Power Logic) module, VBUS detector and the external RESETB pin via the logic shown in the above diagram. UVLO takes the external power supply as input and releases the lock only when the power supply voltage is higher than a preset threshold. When there is USB plugged in, the VBUS_DET detects that VBUS has power and may generate reset after 5ms, however, it can writer pm top register 0x69 bit [6] to 1 to disable this reset generation. The RESETB pin has an internal pull-up resistor; an external capacitor can be connected on the RESETB pin to control the POR delay.

After UVLO, VBUS_DET and RESETB release, there is a further configurable delay before the system reset signal ("Sysrst") is released. The delay is adjusted by analog register afe_0x3e. Since the content of afe_0x3e is reset to default only after power cycle, watchdog reset, or software reset, the delay change using afe_0x3e is only applicable when the chip has not gone through these reset conditions. For example, after deep sleep wakeup, the setting in afe_0x3e will take effect.

The related analog registers are described in table below.

Table 4-9 Analog Register to Control Logic of Power Up/Down

Address	Name	Type	Description	Default Value
afe_0x3e	r_dly	R/W	base on 16KHz frequency increase counter (8ms)	10000000
afe_0x69	pg status	R	[6] vbus_detect (write 1 to disable vbus rst timer)	-

Power up and power down sequences are shown in figures below.

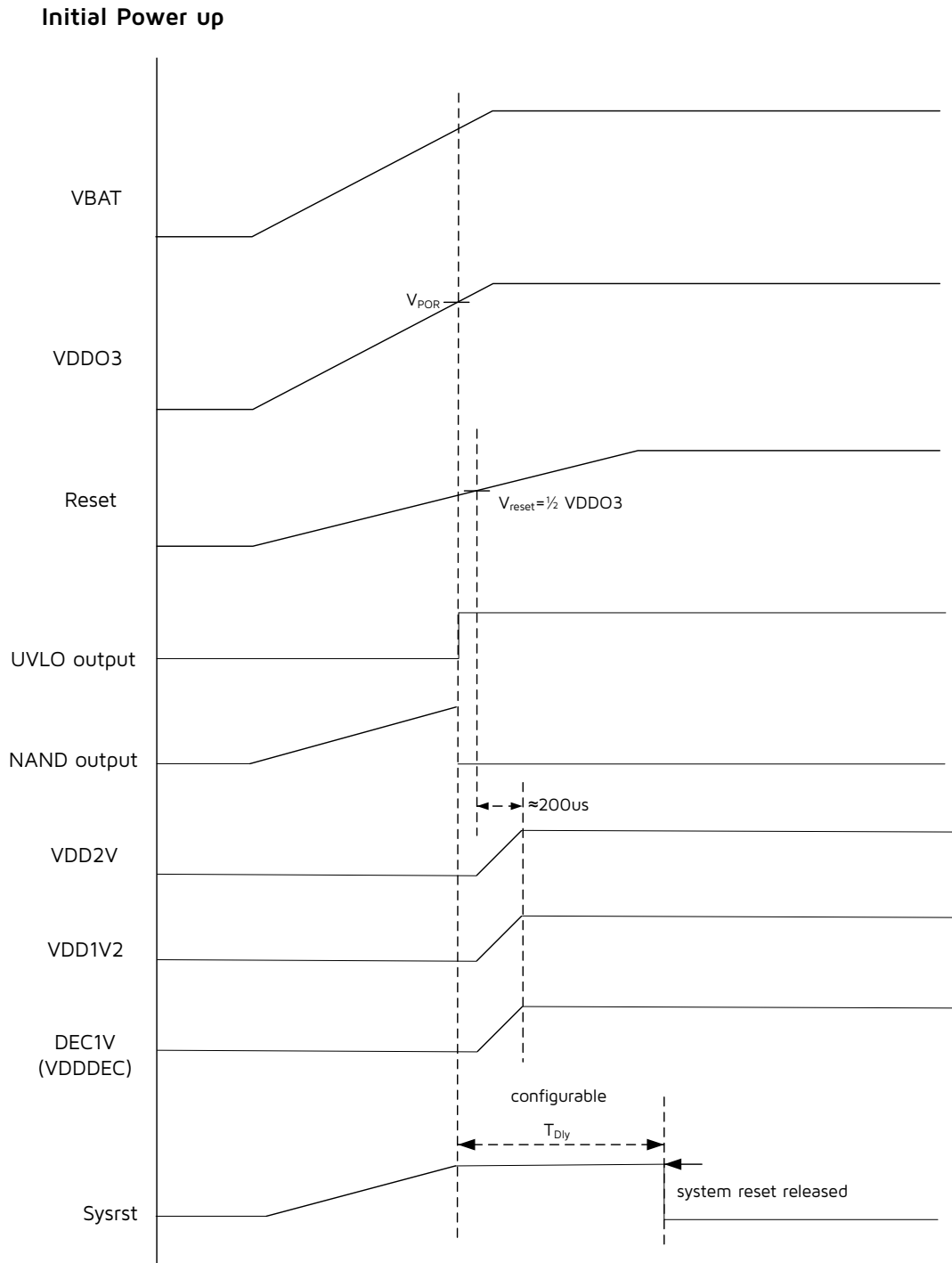
Figure 4-3 Initial Power-up Sequence

NOTE:

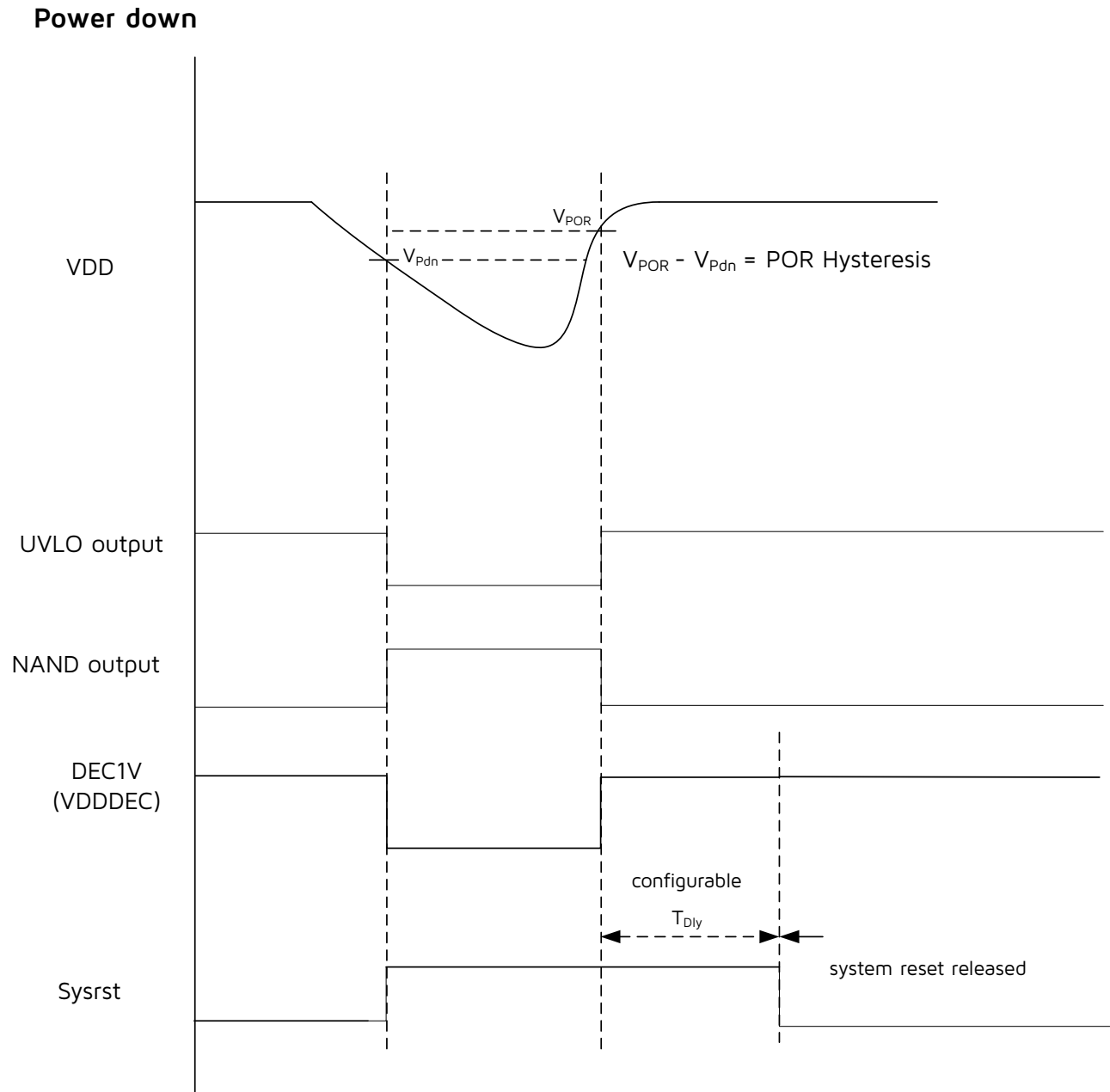
- The VDDO3 actually has no delay relative to VBAT, as the internal circuit is powered by VBAT.

Figure 4-4 Initial Power-down Sequence

Table 4-10 Characteristics of Initial Power-up/Power-down Sequence

Symbol	Parameter	Min.	Typ.	Max.	Unit
V_{POR}	VDD voltage when V_{UVLO} turns to high level	-	1.73	-	V
V_{PDN}	VDD voltage when V_{UVLO} turns to low level	-	1.61	-	V
T_{DLY}	Delay counter value	Configurable via analog register afe_0x3e			

4.5.2 Working Mode Switch

In Active mode, MCU is active, all SRAMs are accessible, and other modules are selectable whether to be at working state.

The chip can switch to Idle mode to stall the MCU. In this mode, all SRAMs are still accessible, modules such as RF transceiver, USB are still selectable whether to be at working state. The chip can be triggered to Active mode by interrupt or RESETB pin, and the time to switch to Active mode is negligible.

To decrease power consumption to different levels, the chip can switch to power saving mode (Suspend, Deep sleep with SRAM retention, Deep sleep without SRAM retention, Shutdown) correspondingly.

- In Suspend mode, MCU stalls, all SRAMs are still accessible, the PM module is active, and modules such as RF transceiver, USB are powered down. The chip can be triggered to Active mode by 32K Timer, IO pin or RESETB pin. It takes 100 μ s or so to switch from Suspend mode to Active mode.
- In Deep sleep with SRAM retention, the PM module is active, analog and digital modules except for the retention SRAMs are powered down, while the retention SRAMs can be retained and not accessible. The chip can be triggered to Active mode by 32K Timer, IO pin or RESETB pin. The time to switch to Active mode is shorter than Deep sleep without SRAM retention and close to Suspend.
- In Deep sleep without SRAM retention, only the PM module is active, while analog and digital modules including the retention SRAMs are powered down. The chip can be triggered to Active mode by 32K Timer, IO pin or RESETB pin. The time to switch to Active mode is 1 ms or so.
- In Shutdown mode, all digital and analog modules are powered down, and only the PM module is active. The chip can be triggered to Active mode by RESETB pin only. The time to switch to Active mode is 10 ms or so.

User can directly invoke corresponding library function to switch working mode of the chip.

If certain module doesn't need to work, user can power down this module in order to save power.

Table 4-11 3.3 V Analog Register for Module Power up/down Control

Address	Type	Description	Reset Value
afe_0x4c	R/W	[0] 1: auto power down 32KRC [1] 1: auto power down 32K xtal [2] 1: auto power down 4M rcosc [3] 1: auto power down 24M xtal [4] 1: auto power power logic [5] 1: auto power down dcdc [6] 1: auto power down vbus LDO [7] 1: auto power down ana/BBPLL/ temp_sensor LDO	0x0

Address	Type	Description	Reset Value
afe_0x4d	R/W	[0] 1: auto power down low power comparator [1] 1: auto power down dcore/sram LDO [2] 1: auto power down UVLO ib [3] 1: auto power down vbus switch [4] 1: auto power down flash LDO [5] rsvd [6] 1: power down sequence enable [7] 1: enable isolation	0x0

4.5.3 LDO and DCDC

The diagram of LDO and DCDC module is shown as following.

Figure 4-5 LDO and DCDC

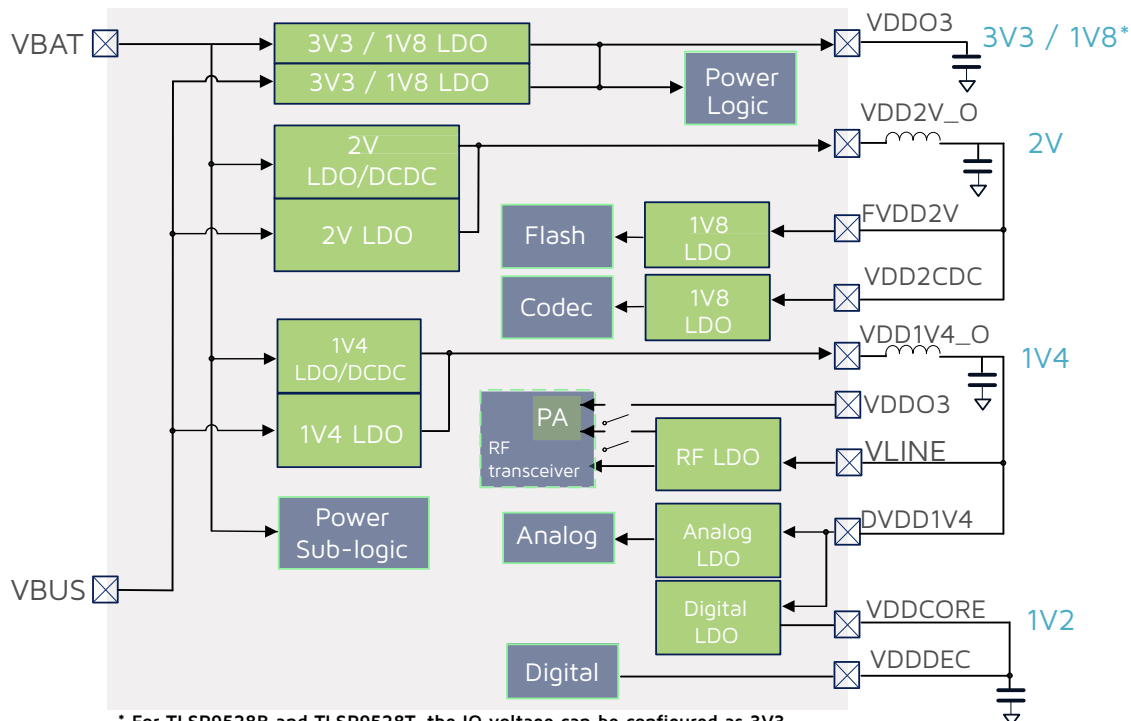

* For TLSR9528B and TLSR9528T, the IO voltage can be configured as 3V3 (CFG_VIO connects to VSS) or 1V8 (CFG_VIO connects to VDDO3/AVDD3). For the internal PA, if VDDO3 is configured as 3V3, the maximum TX power can reach 10 dBm; if configured as 1V8, the maximum TX power can reach 5 dBm.

As shown in figure above, the SoC has two modes of power supply VBAT and VBUS. After power up, the 3.3/1.8 V LDO can generate 3.3/1.8 V output and supply power for Power logic module; the 2 V LDO or 2 V DCDC can generate 2 V voltage output and through internal 1.8V LDOs to supply power for flash and CODEC modules; the 1.4 V LDO or 1.4 V DCDC can generate 1.4 V voltage output as the input of the internal RF LDO, analog LDO and digital LDO; the three LDOs can supply power for RF, Analog, and Digital modules respectively; the digital LDO can generate 1.2 V output as VDDCORE, as well as VDDDEC to supply power for digital signals.

4.5.4 VBAT and VANT Power-Supply Mode

The chip provides two power-supply modes including VBAT mode and VANT mode.

- In VBAT mode, the chip is directly supplied with power by its battery voltage. The maximum output power is related to power supply voltage, for example, the maximum power is 10 dBm or so at 3.3 V power supply.
- In VANT mode, the chip is supplied with 1.2 V voltage by the embedded DCDC and LDO. In this mode, output power won't change with AVDD basically, and the maximum power is 5 dBm or so. Corresponding to the VBAT mode, the VANT mode is more power-saving at the same TX power.

NOTE:

- When the VBAT is in VBAT_MAX_VALUE_LESS_THAN_3V6 mode, the IO voltage of GPIO cannot be configured to 1.8V.
- The VBAT channel detection does not support using 1.8V.

4.6 Wakeup Source

The figure below shows wake up sources of the SoC.

Figure 4-6 Wake up Sources

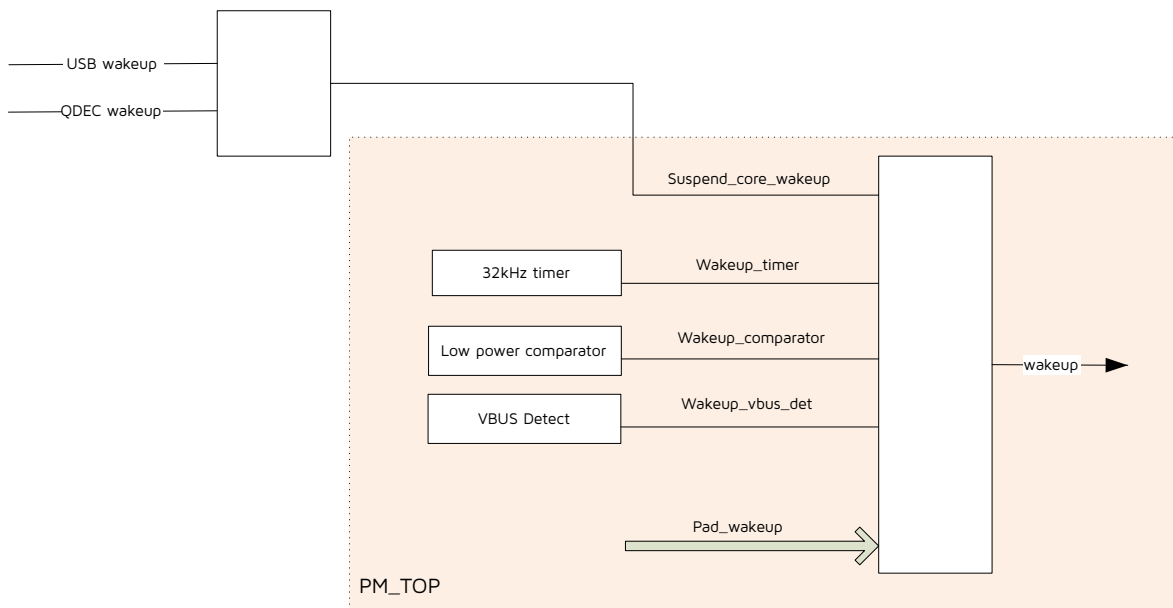

Each wake up source is detailed below:

USB & QDEC

These wakeup sources can only wake up the system from suspend mode.

For USB wakeup, once USB host sends out resuming signal, the system will be woke up.

For QDEC wakeup, it is mainly used in mouse applications, details refer to [Chapter 20 Quadrature Decoder](#).

32 kHz Timer

This wakeup source is able to wake up the system from suspend mode or two deep sleep modes.

Low Power Comparator

This wakeup source is able to wake up the system from suspend mode or two deep sleep modes.

VBUS Detect

This wakeup source is able to wake up the system from suspend mode or two deep sleep modes.

Pad wakeup

This wakeup source is from IO signals and able to wake up the system from suspend mode or two deep sleep modes.

Table 4-12 Analog Register for Wakeup

Address	Type	Description	Default Value
afe_0x3f	R/W	PA_polarity wakeup polarity 0: high level wakeup,1: low level wakeup	0x0
afe_0x40	R/W	PB_polarity wakeup polarity 0: high level wakeup,1: low level wakeup	0x0
afe_0x41	R/W	PC_polarity wakeup polarity 0: high level wakeup,1: low level wakeup	0x0
afe_0x42	R/W	PD_polarity wakeup polarity 0: high level wakeup,1: low level wakeup	0x0
afe_0x43	R/W	PE_polarity wakeup polarity 0: high level wakeup,1: low level wakeup	0x0
afe_0x44	R/W	PF_polarity wakeup polarity 0: high level wakeup,1: low level wakeup	0x0
afe_0x45	R/W	PA wakeup enable	0x0
afe_0x46	R/W	PB wakeup enable	0x0
afe_0x47	R/W	PC wakeup enable	0x0
afe_0x48	R/W	PD wakeup enable	0x0
afe_0x49	R/W	PE wakeup enable	0x0
afe_0x4a	R/W	PF wakeup enable	0x0

Address	Type	Description	Default Value
afe_0x4b	R/W	[0] pad wakeup enable [1] rsvd [2] timer wakeup enable [3] comparator wakeup enable [4] rsvd [5] rsvd [6] VAD wakeup enable [7] shutdown wakeup enable	0x0
afe_0x64	R	write 1 to clean the status: [0]: wkup pad [1]: rsvd [2]: wkup timer [3]: wkup cmp [4]: rsvd [5]: rsvd [6]: wkup vad [7]: watch_dog	-
afe_0x7f	R/W	[3]: vbus_detect_pol, vbus detect wakeup polarity, 1: low level active, 0: high level active [4]: wkup_vbus_en, vbus detect wakeup enable	0x0

5 Audio

This chapter includes audio CODEC and audio FIFO.

5.1 Audio CODEC

5.1.1 Introduction

This figure below shows the gain of the input path and the output path of the audio CODEC.

Figure 5-1 Audio CODEC

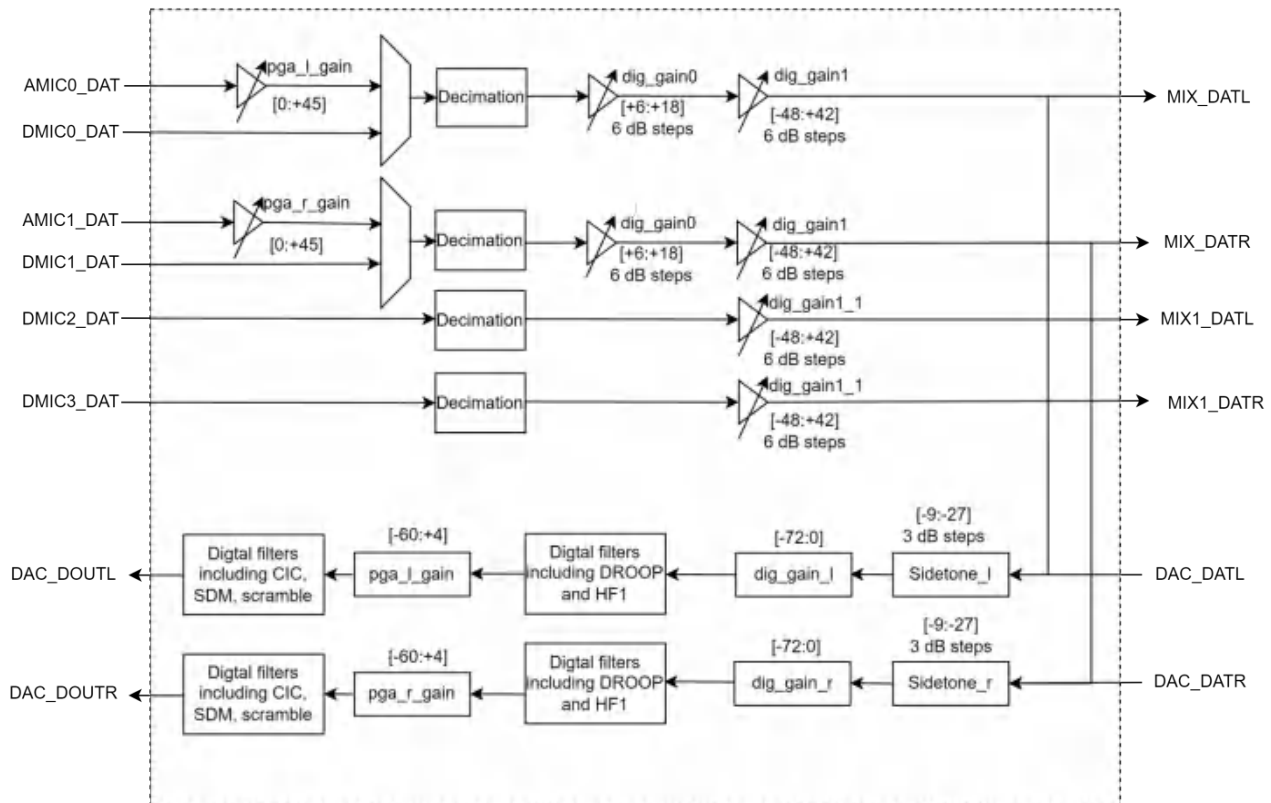

The audio CODEC features include:

- Supports 2 channel ADC
- Supports 4-mono or 2-stereo DMIC
- Supports 2 channel DAC
- Supports sampling rate of 8 kHz, 8.0214 kHz, 11.0259 kHz, 12 kHz, 16 kHz, 22.0588 kHz, 24 kHz, 32 kHz, 44.118 kHz and 48 kHz
- MCLK = 12 MHz
- CODEC data bit width of 16 bits and 20 bits
- CODEC input path consists of analog PGA gain, digital filters, ALC and two digital gains
- CODEC output path consists of sidetone, two digital gains, and digital filters
- CODEC input path analog PGA gain range is 0 ~ 45.2dB; dig_gain0 gain has +6dB, +12dB and +18dB three grades; dig_gain1 gain range is -48dB ~ 42dB

- Sidetone gain range -9dB--27dB, 3dB/step
- Third-order SDM modulation
- Codec output path has a separate linear adjustable gain range of -72dB-0dB at sample rate of 48 kHz; linear adjustable gain range of -60dB-+4dB at 96 kHz

5.1.2 CODEC Input Path

The CODEC input path is illustrated in figure below.

Figure 5-2 CODEC Input Path

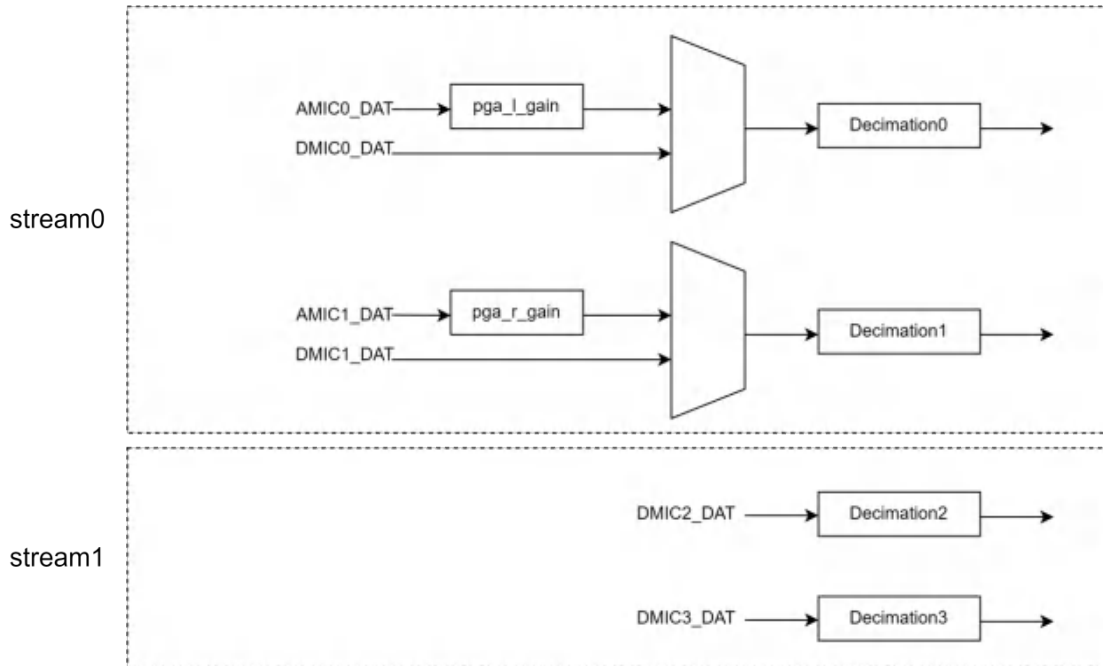

The CODEC input has two groups of streams (stream0 and stream1) and four data paths. The stream0 is used to support dual AMIC input; when AMIC input is needed, set dec0_en (0x8014058b[0]) to 1 to enable stream0 dual decimation, set dec0_en_ch (0x801405a8[1:0]) to 1 to enable the MIC interface module switch, and then configure mic_sel (0x801405a8[3]) to 0 to select the input source as AMIC.

The CODEC supports up to four DMIC inputs, that is, both stream0 and stream1 switch DMIC as input source. The switches of digital filter for stream0 and stream1 are dec0_en (0x8014058b[0]) and dec1_en (0x801405ab[0]), when stream0 selects DMIC as input source, configure mic_sel to 1. The stream1 only supports DMIC input.

5.1.2.1 Decimation Data Path

The following figure shows the data path of the CODEC decimation of this chip, including a CIC filter, two half-band filters, a filter as compensation, and a high pass filter (HPF). The HPF is for filtering DC, and the switch is hpf_en (0x80140580[0]). The decimation output has two formats, one is 20-bit, the other is 16-bit, Set dec0_ain0_mode (80140560[0]) or dec0_ain1_mode (80140560[2]) to 0 to make output as 16-bit format; then set trunc_mode (80140561[6]) to 1 to capture lower 16 bits, otherwise capture higher 16 bits.

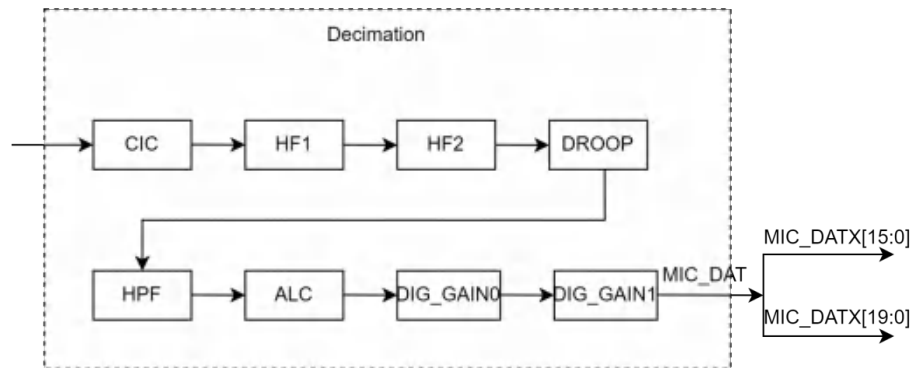
Figure 5-3 Audio CODEC Decimation

The ALC path is shown below and consists of a downsampling filter, ALC&NG, and adjustable gain.

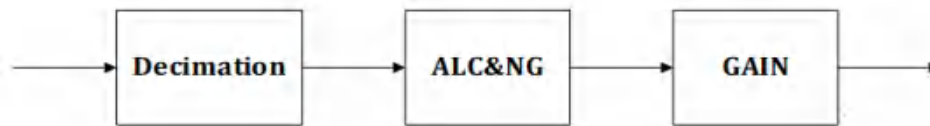
Figure 5-4 Audio ALC Path

The structure of Average filter is shown below and is used to detect the envelope value of the input data. The parameter $\alpha=2^{(-K1)}$, $K1(0x80140585[7:4])$ can be adjusted to regulate the speed of detecting the following envelope.

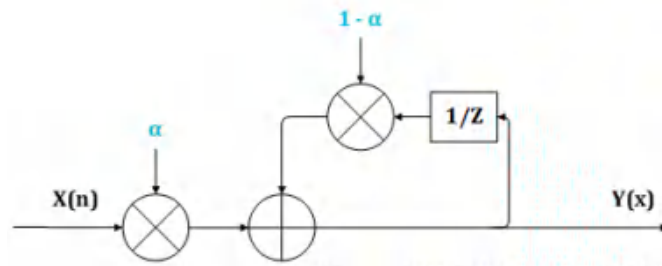
Figure 5-5 Structure of Average Filter

The ALC modules of stream0 and stream1 share a common set of configuration registers. Set ALC_SEL (0x801405a1[6:5]) as the switch for both left and right path ALC; the ALC module will compare the detected envelope value with the configured reference threshold ALCL (0x801405a0[3:0]), and if it is larger than the reference threshold, then reduce the gain, and vice versa increase; change the gain increase/decrease rate by adjusting ATK (0x801405a2[3:0]) and DCY (0x801405a2[7:4]) to change the gain increase/decrease rate. Configure ALC_HLD (0x801405a1[3:0]) when the gain needs to be reduced to make the gain have a hysteresis time in reducing; if the dynamic adjustable gain is greater than MAXGAIN (0x801405a0[6:4]), it will be kept at MAXGAIN, and below MINGAIN (0x801405a4[2:0]), it will be kept at MINGAIN.

Noise Gating is to prevent noise from entering when there is no useful signal during record. The NGAT (0x801405a3[0]) is the switch, NGTH(0x801405a3[7:3]) is the noise threshold. When the detected input signal amplitude is less than the set threshold, it is considered as noise, NGG(0x801405a3[2:1]) is configured as 2'b01 to make the signal softmute.

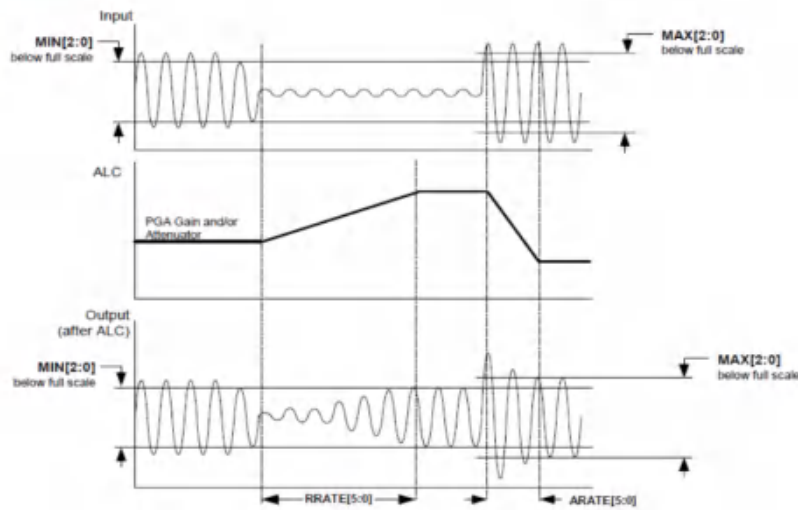
Figure 5-6 Signals before and after ALC

5.1.2.2 Sample Rate of CODEC Input

The master clock mclk of CODEC is divided from pll, the mclk frequency is 12MHz, the input path of CODEC supports sampling rate of 8 kHz ~ 48 kHz, obtained by configuring dec0_clk_sr (0x8014058a[5:1]) or dec1_clk_sr (0x801405ac[4:0]). The dmic_clk is divided from dec_clk.

Table 5-1 Sample Rate of CODEC Input

MCLK	CODEC input sample rate	Coded	dec_clk	dmic_clk = dec_clk/2
12.000MHz	8kHz (MCLK/1500)	00110	mclk/6	1MHz
	8.0214kHz (MCLK/1496)	10111	mclk/5.5	1.092MHz
	11.0259kHz (MCLK/1088)	11001	mclk/4	1.5MHz
	12kHz (MCLK/1000)	01000	mclk/4	1.5MHz
	16kHz (MCLK/750)	01010	mclk/3	2MHz
	22.0588kHz (MCLK/544)	11011	mclk/2	3MHz
	24kHz (MCLK/500)	11100	mclk/2	3MHz
	32kHz (MCLK/375)	01100	mclk/1.5	4MHz
	44.118kHz (MCLK/272)	10001	mclk	6MHz
	48kHz (MCLK/250)	00000	mclk	6MHz

5.1.2.3 Digital Gain of CODEC Input

The 3 registers on the CODEC input data path that control gain: PGA gain, dig_gain0, and dig_gain1.

PGA Gain

Control the left channel of the AMIC by configuring pgavol_in (80140590[3:0]) and the right channel of the AMIC by configuring pgavol_inR (8014059b[3:0]).

Table 5-2 PGA Gain for Different Configurations

Code (4 bits)	PGA Gain (dB)
0000	45.2
0001	43.5
0010	42.1
0011	40.5
0100	39.1
0101	37.4
0110	36.0
0111	34.6
1000	33.0
1001	30.1
1010	27.0
1011	24.0
1100	21.0
1101	15.0
1110	9.0
1111	0

dig_gain0

Dec0 has +6dB, +12dB, +18dB (801405a5[5:4]:2'b1,2'd2,2'd3) three levels of digital gain to control the left and right channels simultaneously.

dig_gain1

There is also a gain range of -48dB~+42dB, 6dB/step while controlling the digital gain of the left and right channels.

By configuring dec0_vol(0x80140561[5:0]) to control the digital gain of the left and right channels of dec0; by configuring dec1_vol(0x80140555[5:0]) to control the digital gain of the left and right channels of dec1.

Table 5-3 Digital Gain for Different Configurations

Gain	Coded
-48dB	0x00

Gain	Coded
-42dB	0x04
-36dB	0x08
-30dB	0x0c
-24dB	0x10
-18dB	0x14
-16dB	0x15
-12dB	0x18
-6dB	0x1c
0dB	0x20
+6dB	0x24
+12dB	0x28
+18dB	0x2c
+24dB	0x30
+30dB	0x34
+36dB	0x38
+42dB	0x3c

5.1.3 CODEC Output Path

5.1.3.1 Data Path of CODEC Output

The figure below shows the data path of the CODEC output of this chip, and Headphone in the figure refers to the analog part.

Figure 5-7 Data Path of CODEC Output

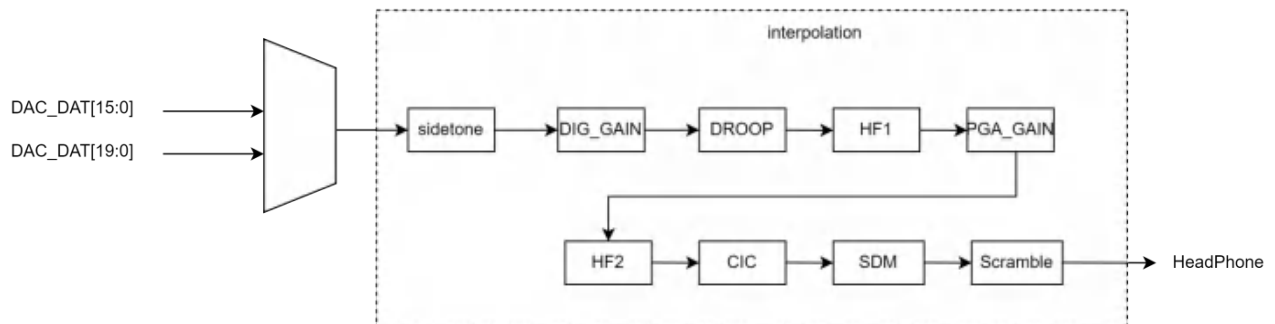

Sidetone

The general application scenario of the sidetone is in the phone call, the human voice collected from the microphone side can be played out from the headphone, the sidetone structure in this chip is shown in the figure below.

Figure 5-8 Sidetone Structure

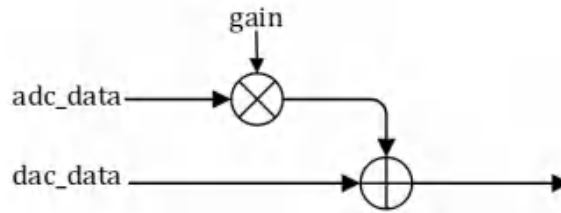

The ADC channel data played in Sidetone's DAC channel will multiply a gain, gain range -9dB ~ -27dB, 3dB/step. Configure `sdtg_l` (0x80140584[4:2]) and `sdtg_r` (0x80140584[7:5]) to get this gain. When `sdtg_l` or `sdtg_r` is 0, the default is bypass.

Table 5-4 Gain of Sidetone

<code>sdtg_l/sdtg_r</code>	gain (dB)
3'b000	-30
3'b001	-27
3'b010	-24
3'b011	-21
3'b100	-18
3'b101	-15
3'b110	-12
3'b111	-9

SDM (Sigma-Delta Modulation)

The SDM modulation in the output path of this chip is third order, configure `dsm_mode` (0x80140580[1]) to select digital DSM mode. Configure it to 0, the transfer function $H(Z)=1+Z^{-1}$, the out-of-band zero position is at (output sampling rate)/2; configure it to 1, the transfer function $H(Z)=1+Z^{-3}$, the out-of-band zero position is at (output sampling rate)/2 and (output sampling rate)/6. In which, the dither part of the switch is configured with `dither_en` (0x80140580[3]), and the added perturbation size is configured with `dither_power` (0x80140581 ~ 0x80140583). The quantizer part of the DSM has a 3bit/4bit option to configure `dsm_opt_sel` (0x8014058f[5]).

CIC Compensation

After CIC interpolation filtering it will cause attenuation in the passband, so there is an optional +0.6dB gain compensation option between CIC and SDM, by configuring `cic_comp_en`(0x8014058f[6]).

Softmute

The softmute function of the output path can be implemented by configuring `int_mute_l`(0x80140584[0]), `int_mute_r`(0x80140584[1]), but the step of softmute is fixed and takes longer time. It can also be achieved

by configuring `pga_mute_l(0x8014058f[3])`, `pga_mute_r(0x8014058d[3])`, and the time of softmute can be controlled by configuring `mute_step_sel(0x801405aa[7:0])`. In default situation, the step is 0xa, the 48kHz sample rate, the softmute time is about 21.2ms. With a configured step of 5, the 48kHz sample rate, the softmute time is about 4.2ms.

5.1.3.2 Sample Rate of CODEC Output

The CODEC output path supports sampling rate of 8 kHz ~ 48 kHz, obtained by configuring `int_clk_sr(0x8014058b[7:3])`.

Table 5-5 Sample Rate of CODEC Output

MCLK	CODEC output sample rate	Coded
12.000MHz	8kHz(MCLK/1500)	00110
	8.0214kHz(MCLK/1496)	10111
	11.0259kHz(MCLK/1088)	11001
	12kHz(MCLK/1000)	01000
	16kHz(MCLK/750)	01010
	22.0588kHz(MCLK/544)	11011
	24kHz(MCLK/500)	11100
	32kHz(MCLK/375)	01100
	44.118kHz(MCLK/272)	10001
	48kHz(MCLK/250)	00000

5.1.3.3 Digital Gain of CODEC Output

1) The left and right channels of the CODEC output channel have an independent linear adjustable gain with the range of -72dB ~ 0dB at the sampling rate of 48 kHz, respectively, obtained by configuring `int_vol_l(0x80140587&0x80140588)` and `int_vol_r(0x80140585&0x80140586)`.

$$\text{dB} = \log_{10}(x/4096)$$

2) At 96kHz there is a linear adjustable gain with the gain range of -60dB ~ +4dB, obtained by configuring `pga_l_gain(0x8014058e&0x8014058f)` and `pga_r_gain(0x8014058c&0x8014058d)`, generally use 0.4dB as a step.

$$\text{dB} = \log_{10}(x/1024)$$

5.2 Audio FIFO

5.2.1 Introduction

Figure 5-9 Block Diagram of Audio FIFO

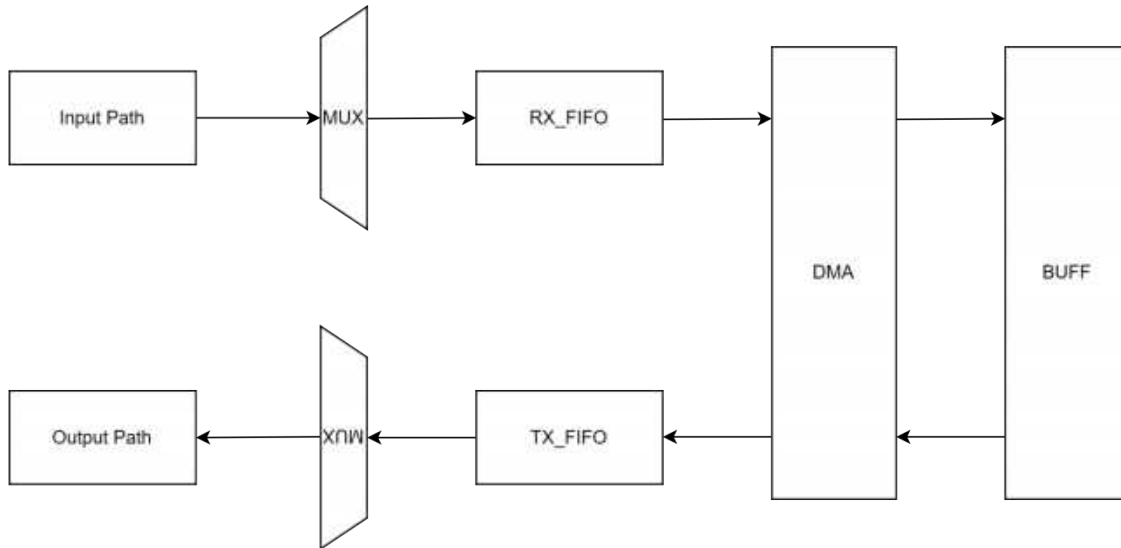

The above figure shows the general block diagram of Audio FIFO, the input path includes I2S, USB, SAR ADC and CODEC. Write to RX_FIFO after selection according to MUX, when the source address is 0x120000 or 0x120040 DMA will move the data from FIFO to user-defined SRAM; when the destination address is 0x120000 or 0x120040 DMA will move the data in SRAM to TX_FIFO. Then select the output path according to MUX, the output path includes I2S, USB and CODEC. Take 16bit stereo i2s0, fifo0 as an example, configure ain0_sel to 3'0, i2s0_ain0_come to 2'b10, aout_sel to 2'b0, i2s0_aout_come to 4'b0010.

Audio FIFO features include:

- The input path includes I2S, USB, SAR ADC and CODEC
- The output path includes I2S, USB and CODEC
- In sync mode, only RXFIFO1 path can be selected

5.2.2 RXFIFO

The following figure shows the input structure of RXFIFO. The RXFIFO input supports a variety of different source multiplexing channels, and the configuration registers can be used to select the channel and data format to meet different requirements.

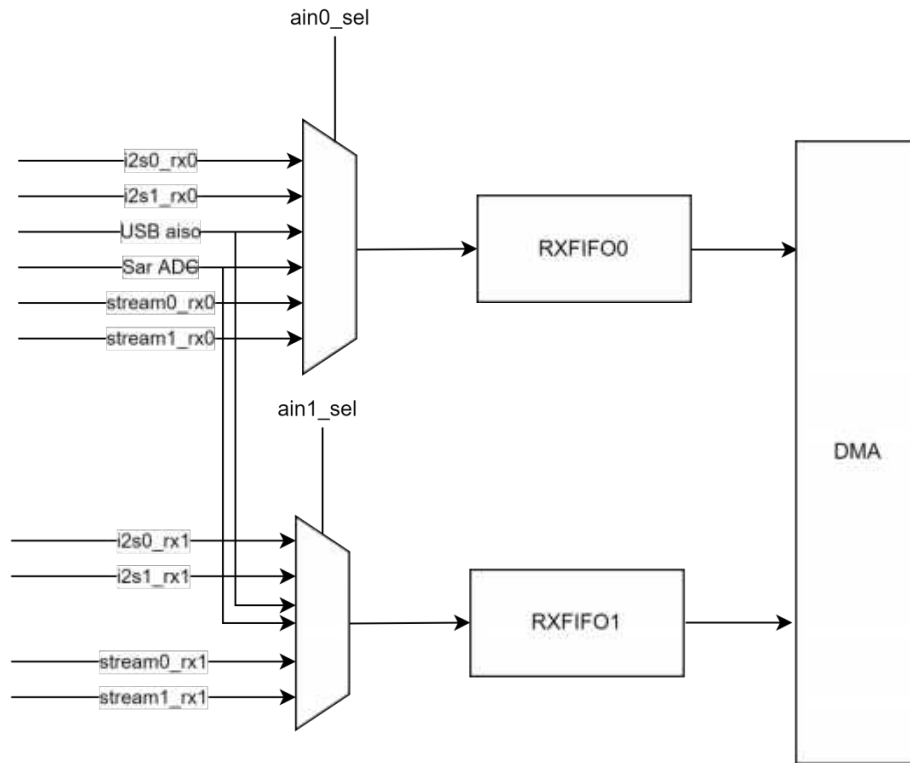
Figure 5-10 RXFIFO Input

Select the input source for the RXFIFO0 path by configuring `ain0_sel`(0x80140505[2:0]). Select the input source for the RXFIFO1 path by configuring `ain1_sel`(0x80140506[2:0]).

Table 5-6 Register of `ain0_sel` and `ain1_sel`

Register	Description
<code>ain0_sel</code>	Rxfifo0 input source select: 3'b000: i2s0. 3'b001: i2s1. 3'b010: usb. 3'b011: sar. 3'b100: codec dec0 3'b101: codec dec1
<code>ain1_sel</code>	Rxfifo1 input source select: 3'b000: i2s0. 3'b001: i2s1. 3'b010: usb. 3'b011: sar. 3'b100: codec dec0 3'b101: codec dec1

5.2.2.1 I2S Data Transfer in RXFIFO

Figure 5-11 I2S Data Transfer in RXFIFO

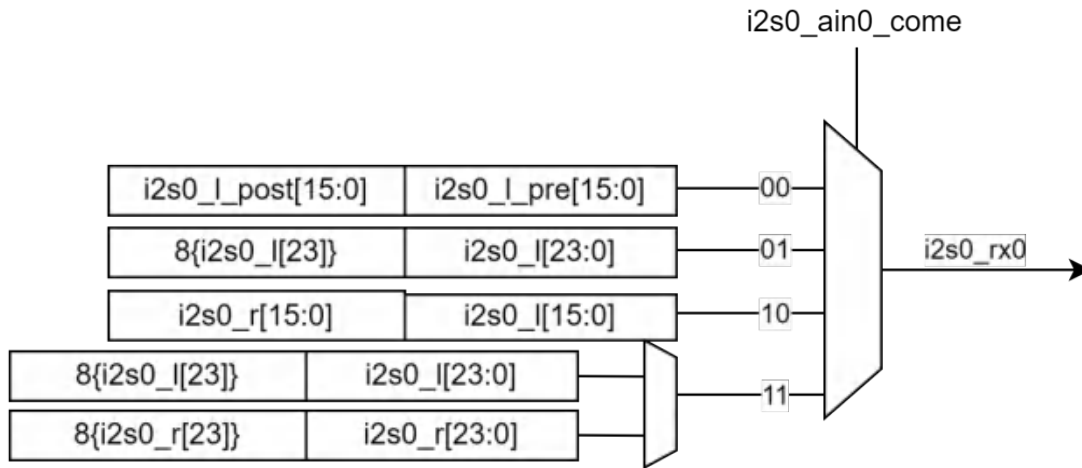

When I2S0 is used as the input source of RXFIFO 0, the data format of I2S0 is selected by configuring `i2s0_ain0_come(0x80140504[1:0])`, as shown in the following table.

Table 5-7 Data format of i2s0_ain0_come

Register	Description
i2s0_ain0_come	Rxfifo0 input mode select:
	2'b00: 16bit mono
	2'b01: 20/24bit mono
	2'b10: 16bit stereo
	2'b11: 20/24bit stereo.

- When `i2s0_ain0_come` selects 16bit mono, it will input the two strokes of i2s0 left channel data into 32bit into FIFO, and the first stroke is located at the low 16bit of 32bit, and the second stroke is the high 16bit of 32bit;
- When `i2s0_ain0_come` selects 20/24bit mono, the left channel will be expanded into 32bit and input into FIFO;
- When `i2s0_ain0_come` selects 16bit stereo, the 16bit data of the left and right channels will be spliced into 32bit and input into FIFO, where the left channel data is the low 16bit of 32bit;
- When `i2s0_ain0_come` selects 20/24bit stereo, it will input the data into FIFO in two strokes, first transmitting the 32bit data of the left channel symbol expansion, and then transmitting the 32bit data of the right channel symbol expansion.

When I2S1 is used as the input source of RXFIFO 0, the data format of I2S1 is selected by configuring `i2s1_ain0_come(0x80140534[1:0])`, as shown in the above table.

Table 5-8 Data format of i2s1_ain0_come

Register	Description
i2s1_ain0_come	rxfifo0 input mode select: 2'b00: 16bit mono 2'b01: 20/24bit mono 2'b10: 16bit stereo 2'b11: 20/24bit stereo.

In addition, when the I2S data is used as the input source of RXFIFO1 is basically the same as RXFIFO0, the only difference is that RXFIFO1 supports i2s_sync_mode 16bit(Ox80140533[0]) and i2s_sync_mode 20/24bit(Ox80140533[1]).

When the RXFIFO1 path is selected, i2s_sync_mode 16bit(Ox33[0]) or i2s_sync_mode20/24bit(Ox33[1]) is set to 1, I2S0/I2S1 multiplex the same DMA channel thus achieving the purpose of data synchronization. The data structure of the two synchronization modes is shown in the following table.

- When register i2s_sync_mode[0] is set to 1, that is, 16bit synchronization, two write FIFO actions will be initiated, the first one transmits 32bit of data splicing around i2s1, of which the lower 16bit is the left channel data of i2s1, the second one transmits 32bit of data splicing around i2s0, of which the lower 16bit is the left channel data of i2s0;
- When register i2s_sync_mode[1] is set to 1, that is, 20bit or 24bit synchronization, four write FIFO actions will be initiated, the first one transmits 32bit data after i2s1 left channel symbol expansion, the second one transmits 32bit data after i2s1 right channel symbol expansion, the third one transmits 32bit data after i2s0 left channel symbol expansion data, and the fourth one transmits the 32bit data after the i2s0 right channel symbol expansion.

Table 5-9 Data Structure of two Synchronization Mode

Sync mode	Data structure
i2s sync mode 16bit	{i2s1_r[15:0], i2s1_l[15:0]}, {i2s0_r[15:0], i2s0_l[15:0]}
i2s sync mode 20bit	{{12{i2s1_l[19]}}, i2s1_l[19:0]}, {{12{i2s1_r[19]}}, i2s1_r[19:0]}, {{12{i2s0_l[19]}}, i2s0_l[19:0]} {{12{i2s0_r[19]}}, i2s0_r[19:0]}
i2s sync mode 24bit	{{8{i2s1_l[23]}}, i2s1_l[23:0]}, {{8{i2s1_r[23]}}, i2s1_r[23:0]}, {{8{i2s0_l[23]}}, i2s0_l[23:0]} {{8{i2s0_r[23]}}, i2s0_r[23:0]}

5.2.2.2 CODEC Data Transfer in RXFIFO

When stream0 is used as the input source of RXFIFO 0, the data format of stream0 is selected by configuring dec0_ain0_mode(Ox80140560[1:0]) as shown in the following table.

Table 5-10 Data format of dec0_ain0_come and dec1_ain0_come

Register	Description
dec0_ain0_come	Rxfifo0 input mode select: 2'b00: 16bit mono 2'b01: 20bit mono 2'b10: 16bit stereo 2'b11: 20bit stereo.
dec1_ain0_come	rxfifo0 input mode select: 3'b000: 16bit mono 3'b001: 20bit mono 3'b010: 16bit stereo 3'b011: 20bit stereo. 3'b100: 16bit stereo(4 channel).

When stream1 is used as the input source of RXFIFO 0, the data format of stream1 is selected by configuring dec1_ain0_mode(0x80140556[2:0]) as shown in the table above, where 4 channel mode means four microphone inputs are multiplexed with rxfifo0 so as to achieve 4 mic synchronization purpose, but only supports 16bit.

The following table shows the format of the data in the RXFIFO:

Table 5-11 Data Format in RXFIFO

Sync mode	Data structure
16bit mono	{channel_l_post[15:0], channel_l_pre[15:0]}
16bit stereo	{channel_r[15:0], channel_l[15:0]}
20bit mono	{{12{channel[19]}}, channel_l[19:0]}
20bit stereo	{{12{channel_l[19]}}, channel_l[19:0]} {{12{channel_r[19]}}, channel_r[19:0]}
4 channel stereo	{channel_l_post[15:0], channel_l_pre[15:0]} {channel_r_post[15:0], channel_r_pre[15:0]}

Also the CODEC data is the same as RXFIFO0 when it is used as the input source of RXFIFO1. The only difference is that when the CODEC data is in mono format, only RXFIFO0 is selected for the left channel data and RXFIFO1 is selected for the right channel data.

5.2.3 TXFIFO

The following figure shows the output structure of TXFIFO, TXFIFO output also supports a variety of different source multiplexing channels.

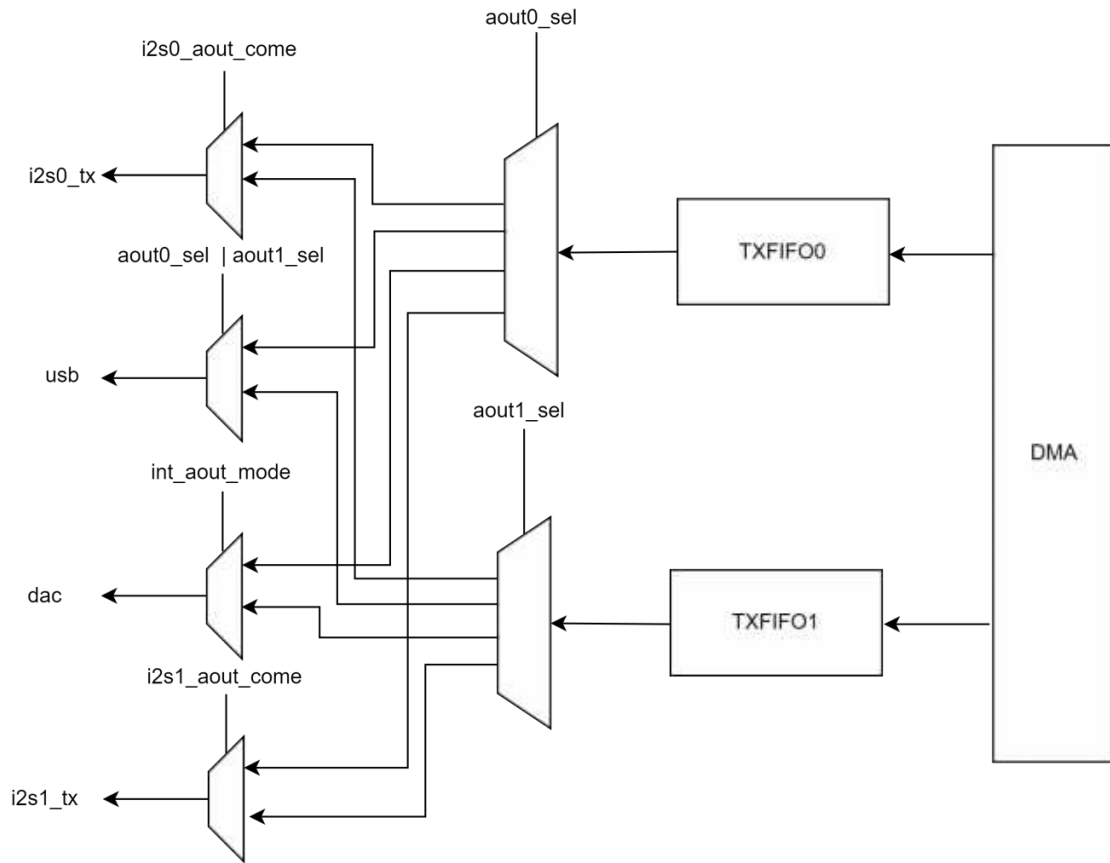
Figure 5-12 TXFIFO Output Structure

Select the output source of the TXFIFO0 path by configuring `aout0_sel`(`0x80140505[4:3]`). Select the input source of the TXFIFO1 path by configuring `aout1_sel`(`0x80140506[4:3]`).

Table 5-12 Register of `aout0_sel` and `aout1_sel`

Register	Description
<code>aout0_sel</code>	txfifo0 output destination select: 2'b00: i2s0. 2'b01: usb. 2'b10: codec dac. 2'b11: i2s1.
<code>aout1_sel</code>	txfifo1output destination select: 2'b00: i2s0. 2'b01: usb. 2'b10: codec dac. 2'b11: i2s1.

5.2.3.1 I2S Data Transfer in TXFIFO

When I2S0 is used as the output source of TXFIFO 0, the data format of I2S0 is selected by configuring `i2s0_aout_come(0x80140504[7:4])`; when I2S1 is used as the output source of TXFIFO 0, the data format of I2S1 is selected by configuring `i2s1_aout_come(0x80140534[7:4])`. Taking `i2s0_aout_come` as an example:

Table 5-13 Data format of `i2s0_aout_come`

Register	Description
<code>i2s0_aout_come</code>	txfifo out mode select: 4'b0000: fifo0 mono 16bit. 4'b0001: fifo0 mono 20/24bit. 4'b0010: fifo0 stereo 16bit. 4'b0011: fifo0 stereo 20/24bit. 4'b0100: fifo1 mono 16bit. 4'b0101: fifo1 mono 20/24bit. 4'b0110: fifo0&fifo1 stereo 16bit. 4'b0111: fifo0&fifo1 stereo 20/24bit. 4'b1000: fifo1 stereo 20/24bit. 4'b1001: fifo1 stereo 16bit.

The configuration of 4'b0110 or 4'b0111 means that two buf data will be input to audio, which is generally only used when the left and right data are in different buf respectively.

NOTE: When i2s synchronous mode this register can not be configured to 4'b0000, 4'b0110 and 4'b0100.

5.2.3.2 CODEC Data Transfer in RXFIFO

When the data of the CODEC is used as the output source of the TXFIFO is exactly the same as i2s, the configuration register `int_aout_mode(80140560[7:4])`, the CODEC data format is only 16bit and 20bit.

5.3 Register Description

The audio path related registers are listed in the table below. The base address for the following registers is 0x80140500.

Table 5-14 Audio Related Registers

Address Offset	Name	Type	Description	Reset Value
0x05	AUDIO_SEL1	RW	[2:0]: ain0_sel, fifo0 input source select: 3'b000: i2s0. 3'b001: i2s1. 3'b010: usb. 3'b011: sar. 3'b100: codec adc0; 3'b101: codec adc1 [4:3]: aout0_sel, fifo0 output source select: 2'b00: i2s0. 2'b01: usb. 2'b10: codec dac. 2'b11: i2s1.	0x1f

Address Offset	Name	Type	Description	Reset Value
0x06	AUDIO_SEL2	RW	[2:0]: ain1_sel, fifo1 input source select: 3'b000: i2s0. 3'b001: i2s1. 3'b010: usb. 3'b011: sar. 3'b100: codec adc0; 3'b101: codec adc1 [4:3]: aout1_sel, fifo1 output source select: 2'b00: i2s0. 2'b01: usb. 2'b10: codec dac. 2'b11: i2s1.	0x1f
0x0a	FIFO_TRIG0	RW	[3:0]: aout0_fifo_trig_num, fifo0 tx trigger number. [7:4]: ain0_fifo_trig_num, fifo0 rx trigger number.	0x17
0x0b	FIFO_TRIG1	RW	[3:0]: aout1_fifo_trig_num, fifo1 tx trigger number. [7:4]: ain1_fifo_trig_num, fifo1 rx trigger number.	0x17
0x0c	aout0_fifo_num	R	[3:0]: aout0_fifo_num, fifo0 tx data number.	0x00
0x0d	ain0_fifo_num	R	[3:0]: ain0_fifo_num, fifo0 rx data number.	0x00
0x0e	aout1_fifo_num	R	[3:0]: aout1_fifo_num, fifo1 tx data number.	0x00
0x0f	ain1_fifo_num	R	[3:0]: ain1_fifo_num, fifo1 rx data number.	0x00
0x11	PTR_EN	RW	[0]: rx0_wptr_en, rx0 write ptr enable [1]: tx0_rptr_en, tx0 read ptr enable [2]: rx1_wptr_en, rx1 write ptr enable [3]: tx1_rptr_en, tx1 read ptr enable	0x0f
0x22	tx0_rptr_r0	R	[7:2]: tx0_rptr0, tx0 read ptr low byte .	0x00
0x23	tx0_rptr_r1	R	[7:0]: tx0_rptr1, tx0 read ptr high byte.	0x00
0x24	txfifo0_th_r0	RW	[7:0]: txfifo0_th0, tx0 fifo rptr threshold low byte.	0x00
0x25	txfifo0_th_r1	RW	[5:0]: txfifo0_th1, tx0 fifo rptr threshold high byte.	0x00
0x26	TX0_MAX0l	RW	[7:0]: tx0_max0l, tx0 fifo depth low byte.	0x00
0x27	TX0_MAX0h	RW	[5:0]: tx0_max0h, tx0 fifo depth high byte.	0x00
0x28	rx0_wptr_r0	RW	[7:2]: rx0_wptr0, rx0 write ptr low byte.	0x00
0x29	rx0_wptr_r1	RW	[7:0]: rx0_wptr1, rx0 write ptr high byte.	0x00
0x2a	rxfifo0_th_r0	RW	[7:0]: rxfifo0_th0, rx0 fifo wptr threshold low byte.	0x00
0x2b	rxfifo0_th_r1	RW	[5:0]: rxfifo0_th1, rx0 fifo wptr threshold high byte.	0x00

Address Offset	Name	Type	Description	Reset Value
0x2e	RX0_MAX0l	RW	[7:0]: rx0_max0l, rx0 fifo depth low byte.	0x00
0x2f	RX0_MAX0h	RW	[5:0]: rx0_max0h, rx0 fifo depth high byte.	0x00
0x33	I2S1_CTRL	RW	[1:0] i2s_sync_mode, i2s sync mode select	0x00
0x40	USB_AUDIO_CTRL	RW	[0] usb_rd_mode, usb data select [1] codec_align_mask, codec align mode mask [2] i2s_align_mask, i2s align mode mask	0x06
0x42	tx1_rptr_r0	R	[7:2] tx1_rptr0, tx1 read ptr low byte.	0x00
0x43	tx1_rptr_r1	R	[7:0] tx1_rptr1, tx1 read ptr high byte.	0x00
0x44	txfifo1_th_r0	RW	[7:0] txfifo1_th0, tx1 fifo rptr threshold low byte.	0x00
0x45	txfifo1_th_r1	RW	[5:0] txfifo1_th1, tx1 fifo rptr threshold high byte.	0x00
0x46	TX1_MAX0l	RW	[7:0] tx1_max0l, tx1 fifo depth low byte.	0x00
0x47	TX1_MAX0h	RW	[5:0] tx1_max0h, tx1 fifo depth high byte.	0x00
0x48	rx1_wptr_r0	R	[7:2] rx1_wptr0, rx1 write ptr low byte.	0x00
0x49	rx1_wptr_r1	R	[7:0] rx1_wptr1, rx1 write ptr high byte.	0x00
0x4a	rxfifo1_th_r0	RW	[7:0] txfifo1_th0, rx1 fifo wptr threshold low byte.	0x00
0x4b	rxfifo1_th_r1	RW	[5:0] txfifo1_th1, rx1 fifo wptr threshold high byte	0x00
0x4e	RX1_MAX0l	RW	[7:0] rx1_max0l, rx1 fifo depth low byte.	0x00
0x4f	RX1_MAX0h	RW	[5:0] rx1_max0h, rx1 fifo depth high byte.	0x00
0x55	CODEC1_VOLL	RW	[5:0] dec1_vol, adc1 volume: 0x00: -48dB; 0x18: -12dB; 0x1c: -6dB; 0x20: 0dB; 0x24: 6dB; 0x3c: 42dB	0x20
0x56	CODEC1_SEL	RW	[2:0] dec1_ain0_mode, fifo0 input mode select: 3'b000: 16bit mono. 3'b001: 20bit mono. 3'b010: 16bit stereo. 3'b011: 20bit stereo. 3'b100: 16bit stereo(4 channel mode). [6:4] dec1_ain1_mode, fifo1 input mode select: 3'b000: 16bit mono. 3'b001: 20bit mono. 3'b010: 16bit stereo. 3'b011: 20bit stereo. 3'b100: 16bit stereo(4 channel mode).	0x00

Address Offset	Name	Type	Description	Reset Value
0x57	ALIGN_CTRL	RW	[0] codec_align_en, codec align mode enable: 1'b0: disable; 1'b1: enable [1] i2s_align_en, i2s align mode enable: 1'b0: disable; 1'b1: enable [2] i2s_align_clk_sel, i2s align clk select: 1'b0: i2s0 clk; 1'b1: i2s1 clk [3] i2s_clk_sel, i2s0&i2s1 clk select: 1'b0: i2s0 clk-> i2s0, i2s1 clk-> i2s1; 1'b1: i2s align clk [5:4] i2s_align_ctrl, i2s0&i2s1 align enable independently, [5]-> i2s1; [4]-> i2s0 [7:6] adc&dac align enable independently, [7]-> dac; [6]-> adc	0xb0
0x58	CODEC_TIME R_TH0	RW	[7:0] codec_timer_th0, codec sys timer tick threshold 0 byte.	0xff
0x59	CODEC_TIME R_TH1	RW	[7:0] codec_timer_th1, codec sys timer tick threshold 1 byte.	0xff
0x5a	CODEC_TIME R_TH2	RW	[7:0] codec_timer_th2, codec sys timer tick threshold 2 byte.	0xff
0x5b	CODEC_TIME R_TH3	RW	[7:0] codec_timer_th3, codec sys timer tick threshold 3 byte.	0x03
0x60	CODECO_SE L	RW	[1:0] dec0_ain0_mode, fifo0 input mode select: 2'b00: 16bit mono. 2'b01: 20bit mono. 2'b10: 16bit stereo. 2'b11: 20bit stereo. [3:2] dec0_ain1_mode, fifo1 input mode select: 2'b00: 16bit mono. 2'b01: 20bit mono. 2'b10: 16bit stereo. 2'b11: 20bit stereo. [7:4] int_aout_mode, fifo out mode select: 4'b0000: fifo0 mono 16bit. 4'b0001: fifo0 mono 20bit. 4'b0010: fifo0 stereo 16bit. 4'b0011: fifo0 stereo 20bit. 4'b0100: fifo1 mono 16bit. 4'b0101: fifo1 mono 20bit. 4'b0110: fifo0&fifo1 stereo 16bit. 4'b0111: fifo0&fifo1 stereo 20bit. 4'b1000: fifo1 stereo 20bit. 4'b1001: fifo1 stereo 16bit.	0x00
0x61	CODECO_VO L	RW	[5:0] dec0_vol, adc0 volume: 0x00: -48dB; 0x18: -12dB; 0x1c: -6dB; 0x20: 0dB; 0x24: 6dB; 0x3c: 42dB [6] trunc_mode, dec gain truncation select. [7] int_bit_sel, int data format select.	0x20
0x62	FIFO_PTR_IR Q_MASK	RW	[0] rxfifo0_irq_en, rxfifo0 printer interrupt enable [1] txfifo0_irq_en, txfifo0 printer interrupt enable [2] rxfifo1_irq_en, rxfifo1 printer interrupt enable [3] txfifo1_irq_en, txfifo1 printer interrupt enable	0x00

Address Offset	Name	Type	Description	Reset Value
0x63	FIFO_PTR_IRQ_STATE	W1C	[0] rxfifo0_irq_st, rxfifo0 printer interrupt flag [1] txfifo0_irq_st, txfifo0 printer interrupt flag [2] rxfifo1_irq_st, rxfifo1 printer interrupt flag [3] txfifo1_irq_st, txfifo1 printer interrupt flag	0x00

The CODEC related registers are listed in the table below. The base address for the following registers is 0x80140580.

Table 5-15 CODEC Related Registers

Address Offset	Name	Type	Description	Reset Value
0x00	DSM_CTRL	RW	[0]: hpf_en, digital high pass filter enable: 1'b1: enable; 1'b0: disable. [1]: dsm_mode, digital delta-sigma modulator mode select: 1'b1: $1+z^{-3}$; 1'b0: $1+z^{-1}$ [2]: scramble_en, digital dsm out scramble enable: 1'b1: enable; 1'b0: disable. [3]: dither_en, digital dsm dither enable: 1'b1: enable; 1'b0: disable. [4]: dec0_swap, adc0 data swap enable: 1'b1: enable; 1'b0: disable. [5]: int_swap, dac data swap enable, 1'b1: enable; 1'b0: disable.	0x85
0x01	DITHER_POWER_1	RW	[6:0] dither_pow_1, dither power high byte	0x04
0x02	DITHER_POWER_2	RW	[7:0] dither_pow_2, dither power mid byte	0xfd
0x03	DITHER_POWER_3	RW	[7:0] dither_pow_3, dither power low byte	0xf3
0x04	SIDETONE	RW	[0] int_mute_l, DAC left volume soft mute [1] int_mute_r, DAC right volume soft mute [4:2] sdtg_l, gain control of left channel sidetone [7:5] sdtg_r, gain control of right channel sidetone	0x00
0x05	INT_VOL_R_1	RW	[3:0] int_vol_r, DAC right channel volume high byte [7:4] alc_k1, k1 factor for ALC	0x5e
0x06	INT_VOL_R_2	RW	[7:0] int_vol_r, DAC right channel volume low byte	0x42
0x07	INT_VOL_L_1	RW	[3:0] int_vol_l, DAC left channel volume high byte [7:4] alc_k2, k2 factor for ALC	0x4e

Address Offset	Name	Type	Description	Reset Value
0x08	INT_VOL_L_2	RW	[7:0] int_vol_l, DAC left channel volume low byte	0x42
0x0a	CLK_CTRL_1	RW	[0] clk_usb, clk usb mode select, 1'b0: normal mode; 1'b1: usb mode [5:1] dec0_clk_sr, adc0 sample rate config [6] clk_div2, mclk div2 enable, 1'b0: mclk not divide; 1'b1: mclk divide2 [7] clk0_en, codec0 mclk enable, 1'b0: mclk disable; 1'b1: mclk enable	0x00
0x0b	CLK_CTRL_2	RW	[0] dec0_en, ADC0 decimation filter enable, 1'b0: disable; 1'b1: enable [1] int_en, DAC interpolation filter enable, 1'b0: disable; 1'b1: enable [7:3] int_clk_sr, dac sample rate config	0x00
0x0c	PGA_GAIN_R_1	RW	[7:0] pga_gain_r, DAC right channel pga gain low byte	0x00
0x0d	PGA_GAIN_R_2	RW	[2:0] pga_gain_r, DAC right channel pga gain high byte [3] pga_mute_r, DAC right channel soft mute, 1'b0: disable; 1'b1: enable	0x04
0x0e	PGA_GAIN_L_1	RW	[7:0] pga_gain_l, DAC left channel pga gain low byte	0x00
0x0f	PGA_GAIN_L_2	RW	[2:0] pga_gain_l, DAC left channel pga gain high byte [3] pga_mute_l, DAC left channel soft mute, 1'b0: disable; 1'b1: enable [4] dsm_gcoef_sel, sigma-delta modulator g coefficient select 1'b1: opt1, 2 ⁻¹⁰ +2 ⁻¹¹ ; 1'b0: opt2, 2 ⁻¹¹ [5] dsm_opt_sel, sigma-delta modulator quantizer select 1'b1: opt1, 3bit; 1'b0: opt2, 4bit [6] cic_comp_en, cic filter compensation enable, 1'b0: disable; 1'b1: enable	0x34
0x10	ANA_REG_0	RW	[3:0] PGAVOL_IN, The volume control of the input stage of PGA of left channel. 0db~45db 4'b1111:0db 4'b1110:9.0db 4'b1101:15.0db 4'b1100:21.0db 4'b1011:24.0db 4'b1010:27.0db 4'b1001:30.1db 4'b1000:33.0db 4'b0111:34.6db 4'b0110:36.0db 4'b0101:37.4db 4'b0100:39.1db 4'b0011:40.5db 4'b0010:42.1db 4'b0001:43.5db 4'b0000:45.2db	0x07

Address Offset	Name	Type	Description	Reset Value
0x11	ANA_REG_1	RW	[0] INMUTE_PGA, 1'b1:mute the input gain stage of PGA [1] MUTE_PGA, 1'b1:PGA is mute [2] PD_PGABUF, 1'b1:the left PGA S2D buffer is power down [3] PD_PGABOOST, 1'b1:the left PGA boost stage is power down [4] PD_INPPGA, 1'b1:the left INPPGA is power down	0x00
0x12	ANA_REG_2	RW	[1:0] ASDM_DITH, dither amplitude.2'b00:vdd/48 2'b01:vdd/24 2'b10:vdd/12 2'b11:vdd/6 [2] ASDM_DITHEEN, dither enable [3] ASDM_DITHIN [4] ASDMDEM_EN, the left channel ASDM DEM enable [5] CTR_IREF, the current bias control bit. 1'b1:the current is half [6] PD_ASDM, power down ASDM	0x00
0x13	ANA_REG_3	RW	[0] PDPAL, Power down left channel PA [1] PDPAR, Power down right channel PA [2] PDSCFL, power down left channel DAC [3] PDSCFR, power down right channel DAC [5:4] SCF_CTL, DAC bias current ctrl:2'b00:default 2'b01:0.5x 2'b10:0.75x 2'b11:1.25x	0x00
0x14	ANA_REG_4	RW	[1:0] VMDSEL, Vmid impedance select.2'b0:472k/2;2'b1:236k/ 2;2'd2:30k/2;2'd3:6k/2 [3:2] PD_VMID, power down VMID [6:5] IBSEL, codec current select. 2'd0:x4/3;2'd1:default;2'd2:x6/ 3;2'd3:x2/3	0x60

Address Offset	Name	Type	Description	Reset Value
0x15	ANA_REG_5	RW	[0] LVEN, DAC/DRV/Vrefbuf Ibias current select LV_EN IBSEL[1:0] Ib3u 0 11 3.07uA(default) 0 10 1.7uA 0 01 2.18uA 0 00 2.54uA 1 11 5.0uA 1 10 2.18uA 1 01 3.0uA 1 00 3.8uA [1] PDMICBIAS, reserved [2] PDBIAS, 1'b1:the current bias is power down.	0x00
0x16	ANA_REG_6	RW	[0] L_HP_ctrl_vref, 1'b1:Enable high-performance Vref_buf. [1] L_INT_vref, 1'b1:Bypass the Vref_buf LPF filter. [2] L_LP_ctrl_vref, 1'b1:enable low-performance Vref_buf. [3] L_LP_ctrl_dacL, 1'b1:enable low-performance left DAC. [4] L_LP_ctrl_dacR, 1'b1:enable low-performance right DAC. [5] L_LP_ctrl_drvL, 1'b1:enable low-performance left driver. [6] L_LP_ctrl_drvR, 1'b1:enable low-performance right driver.	0x01
0x17	ANA_REG_7	RW	[0] L_FRC_ON_DRVL, Force turn on left DRV control signal. 1'b1, force on DRV enable; 1'b0, disable force on function. [1] L_FRC_ON_DRVR, Force turn on right DRV control signal. 1'b1, force on DRV enable; 1'b0, disable force on function. [2] L_HP_ctrl_drvL, 1'b1:enable high-performance left driver. [3] L_HP_ctrl_drvR, 1'b1:enable high-performance right driver.	0x00
0x18	ANA_REG_8	RW	[2:0] Ido_adc_trim, change Ido adc output step:50mV 3'b000:1.6V 3'b001:1.65V 3'b010:1.7V 3'b011:1.75V 3'b100(default):1.8V 3'b101:1.85V 3'b110:1.9V 3'b111:1.95V [3] Ido_adc_en_vo_2p0, Ido adc output 2.0V enable	0x04
0x19	ANA_REG_9	RW	[2:0] Ido_dac_trim, change Ido dac output step:50mV 3'b000:1.6V 3'b001:1.65V 3'b010:1.7V 3'b011:1.75V 3'b100(default):1.8V 3'b101:1.85V 3'b110:1.9V 3'b111:1.95V [3] Ido_dac_en_vo_2p0, Ido dac output 2.0V enable	0x04

Address Offset	Name	Type	Description	Reset Value
0x1a	ANA_REG_10	RW	[2:0] ldo_pa_trim, change ldo pa output step:50mV 3'b000:1.6V 3'b001:1.65V 3'b010:1.7V 3'b011:1.75V 3'b100(default):1.8V 3'b101:1.85V 3'b110:1.9V 3'b111:1.95V [3] ldo_pa_en_vo_2p0, ldo pa output 2.0V enable	0x04
0x1b	ANA_REG_11	RW	[3:0] PGAVOL_INR, The volume control of the input stage of PGA of right channel.0db~45db 4'b1111:0db 4'b1110:9.0db 4'b1101:15.0db 4'b1100:21.0db 4'b1011:24.0db 4'b1010:27.0db 4'b1001:30.1db 4'b1000:33.0db 4'b0111:34.6db 4'b0110:36.0db 4'b0101:37.4db 4'b0100:39.1db 4'b0011:40.5db 4'b0010:42.1db 4'b0001:43.5db 4'b0000:45.2db [4] LVEN_ADC, ADC/Micbias current select: 3'b000:2.54uA; 3'b001:3.8uA; 3'b010:2.18uA; 3'b011:3.0uA; 3'b100:1.7uA; 3'b101:2.18uA; 3'b110:3.07uA(default); 3'b111:5.0uA [6:5] IBSEL_ADC [7] PDBIAS_ADC, power down bias adc	0x67
0x1c	ANA_REG_12	RW	[0] INMUTE_PGAR, 1'b1:mute the input gain stage of PGA of right channel [1] MUTE_PGAR, 1'b1:right channel PGA is mute [2] PD_PGABUFR, 1'b1:the right PGA S2D buffer is power down. [3] PD_PGABOOSTR, 1'b1:the right PGA boost is power down. [4] PD_INPPGAR, 1'b1:the right INPPPGA is power down	0x00
0x1d	ANA_REG_13	RW	[1:0] ASDM_DITHR, the right channel current select. 2'd0:Vdd/48; 2'd1:Vdd/24; 2'd2:Vdd/12; 2'd3:Vdd/6 [2] ASDM_DITHEENR, the right channel dither enable [3] ASDM_DITHINR [4] ASDMDEM_ENR, the right channel ASDM DEM enable [5] CTR_IREFR, the right channel current bias control bit.1'b1:PGA current/2. [6] PD_ASDMR, power down the right channel of ASDM	0x00
0x20	ALC_CTL_0	RW	[3:0] ALCL, ALC target-sets signal level at ADC input 4'b0000:-28.5dB FS 4'b0001:-27.0dB FS...(1.5dB steps) 4'b1110:- 7.5dB FS 4'b1111:-6dB FS [6:4] MAXGAIN, Set max gain of PGA.3'b111:30dB 3'b110:24dB...(- 6dB setp)... 3'b000:-12dB	0x7b

Address Offset	Name	Type	Description	Reset Value
0x21	ALC_CTL_1	RW	[3:0] HLD, ALC hold time before gain is increased. 4'b0000:0ms 4'b0001:2.67ms 4'b0010:5.33ms...(time doubles with every step) 4'b1111:43.691ms [6:5] ALCSEL, ALC function select. 2'b00:ALC off 2'b01:Right channel only 2'b10:Left channel only 2'b11:Setereo	0x00
0x22	ALC_CTL_2	RW	[3:0] ATK, ALC attack(gain ramp-down) time. 4'b0000:6ms 4'b0001:12ms 4'b0010:24ms...(time doubles with every step) 4'b1010 or higher=6.14s [7:4] DCY, ALC delay(gain ramp-down) time. 4'b0000:24ms 4'b0001:48ms 4'b0010=96ms...(time doubles with every step)4'b1010 or higher=24.58s	0x32
0x23	ALC_CTL_3	RW	[0] NGAT, Noise gate function enable. 1'b1:enable 1'b0:disable [2:1] NGG, Noise gate type. X0 = PGA gain held constant, 2'b01=mute ADC output, 2'b11=reserved [7:3] NGTH, Noise gate threshold. 5'b00000:-76.5dBfs 5'b00001:- 75dBfs...1.5dB steps 5'b11110:-31.5dBfs 5'b11111:-30dBfs	0x00
0x24	ALC_CTL_4	RW	[2:0] MINGAIN, Set min gain of PGA.3'b111:-30dB 3'b110:-36dB...(- 6dB setp)... 3'b000:-72dB	0x02
0x25	ALC_CTL_5	RW	[0] DACLINV, Left channel DAC signal invert ctrl [1] DACRINV, Right channel DAC signal invert ctrl [2] INT_GAIN, dac digit gain:1'b1:X2(6db) [5:4] DEC_GAIN, 2'd1:X2,2'd2:X4,2'd3:X8 [7] DIGMIX, (L+R)/2	0x00
0x28	MIC_CTRL	RW	[1:0] dec0_en_ch, dec0 mic interface enable, 1'b0:disable, 1'b1: enable [2] r_neg, 1'b1:dmic data is sync by scan mode clk [3] mic_sel, 1'b1:dmic 1'b0:amic [7:6] r_if	0x40

Address Offset	Name	Type	Description	Reset Value
0x29	ADC_1M_CLK_CTRL	RW	[0] clk_1m_en, 1M clk enable [1] clk_1m_sel, clk select: 1'b1:6M (better performance); 1'b0:1M. [3:2] dec_sft_ctrl, dec data shift. 2'b0:<<8; 2'b1:<<7; 2'd2:<<9; 2'd3:<<9 [4] softmute_mode_sel, dac pga softmute enable [5] ana_pa_clk_6m_en, fix 6m clk for analog [6] dmic_clk_mode, dmic clk mode select [7] dsm_debug_sel, codec dac 1bit dsm out for debug, 1'b1: right channel; 1'b0: left channel	0x01
0x2a	MUTE_STEP_SEL	RW	[7:0] mute_step_sel, dac pga softmute step	0x0a
0x2b	DEC1_CTRL0	RW	[0] dec1_en, ADC1 decimation filter enable, 1'b0: disable; 1'b1: enable [1] clk1_en, codec1 mclk enable, 1'b0: mclk disable, 1'b1: mclk enable [3:2] dec1_en_ch, dec1 mic interface enable, 1'b0:disable; 1'b1: enable [4] dec1_swap, adc1 data swap enable, 1'b1: enable; 1'b0: disable	0x00
0x2c	DEC1_CTRL1	RW	[4:0] dec1_clk_sr, adc1 sample rate config [5] dac_clk_sel, 1'b1:dac output clk select ~int_clk_div; 1'b0:dac output clk select int_clk_div	0x00

6 BT/BLE/2.4GHz RF Transceiver

6.1 Overview

The SoC integrates an advanced RF transceiver for Dual-Mode (BLE + BR/EDR), 802.15.4 and 2.4 GHz application.

This RF transceiver works in the worldwide 2.4 GHz ISM band and it consists of a fully integrated RF synthesizer, a Power Amplifier (PA), a Low Noise Amplifier (LNA), a TX LPF, a Rx complex filter, a TX DAC, a RX ADC, BLE/BT modulator/Demodulator and on-chip balun.

The Classic Bluetooth mode works in standard-compliant BR mode / EDR2 mode and EDR3 mode.

The BLE mode works in standard-compliant 1 Mbps BLE mode, 2 Mbps enhancement BLE mode, 125 Kbps BLE long range mode (S8), 500kbps BLE long range mode (S2).

The Zigbee mode works in IEEE 802.15.4 standard-compliant 250 Kbps mode.

The block diagram of the transceiver is shown below.

Figure 6-1 Block Diagram of RF Transceiver

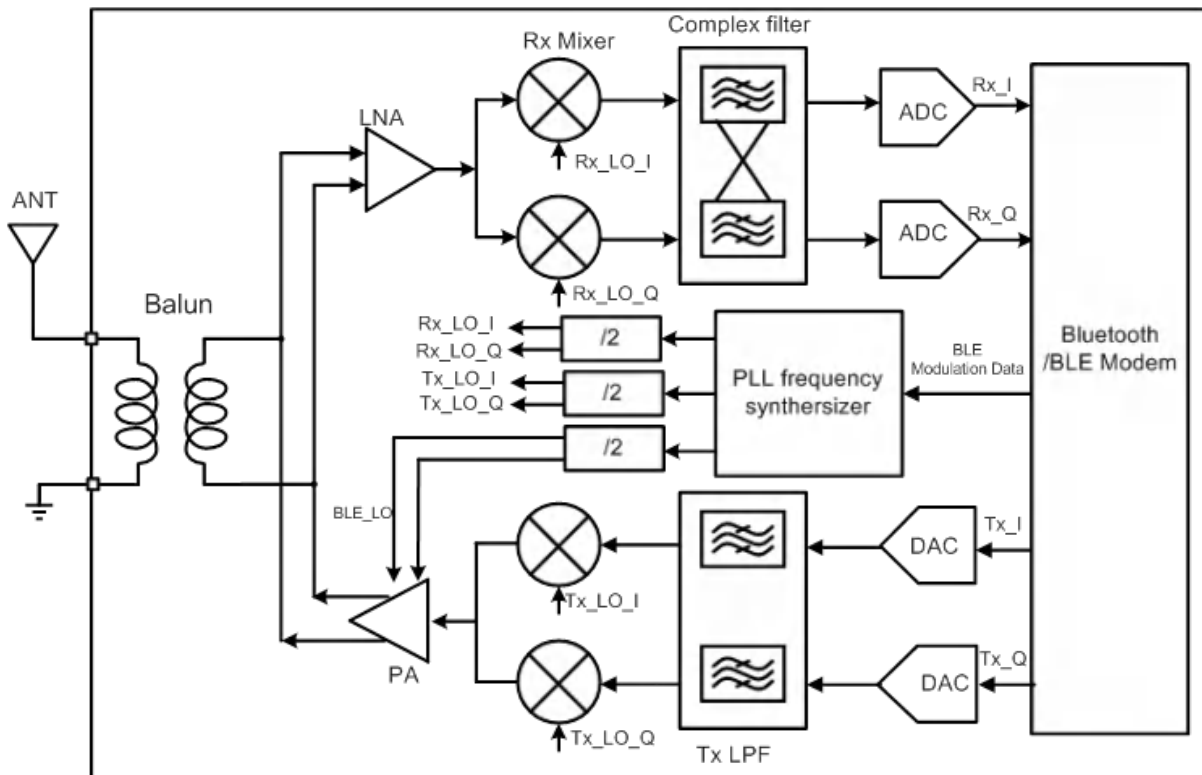

6.2 Air Interface Data Rate and RF Channel Frequency

Air interface data rate, the modulated signaling rate for RF transceiver when transmitting and receiving data, is configurable via related register setting: 125 kbps, 250 kbps, 500 kbps, 1 Mbps, 2 Mbps, 3 Mbps.

RF transceiver can operate with frequency ranging from 2.400 GHz to 2.4835 GHz. The RF channel frequency setting determines the center of the channel.

6.3 Baseband

The baseband is disabled by default. The corresponding API is available for user to power on/down the baseband and enable/disable clock, so that the baseband can be turned on/off flexibly.

The baseband contains dedicated hardware logic to perform fast AGC control, access code correlation, CRC checking, data whitening, encryption/decryption and frequency hopping logic.

The baseband supports all features required by Bluetooth LE and 802.15.4 specification.

6.3.1 Packet Format

Packet format in standard 1 Mbps BLE mode is shown in table below.

Table 6-1 Packet Format in Standard 1 Mbps BLE Mode

LSB				MSB
Preamble (1 octet)	Access Address (4 octets)	PDU (2 ~ 257 octets)	CRC (3 octets)	

Packet length 80 bit ~ 2120 bit (80 ~ 2120 μ s @ 1 Mbps).

Packet format in standard 2 Mbps BLE mode is shown in table below.

Table 6-2 Packet Format in Standard 2 Mbps BLE Mode

LSB				MSB
Preamble (2 octet)	Access Address (4 octets)	PDU (2 ~ 257 octets)	CRC (3 octets)	

Packet length 88 bit ~ 2028 bit (44 ~ 1064 μ s @ 2 Mbps).

Packet format in standard 500kbps/125kbps BLE mode is shown in table below.

Table 6-3 Packet Format in Standard 500 kbps/125 kbps BLE Mode

LSB						MSB
Preamble (10 octet)	Access Address (4 octets)	CI (2 bits)	TERM1 (3 bits)	PDU (2 ~ 257 octets)	CRC (3 octets)	TERM2 (3 bits)

Packet format in 250 kbps 802.15.4 mode is shown in table below.

Table 6-4 Packet Format in 802.15.4 Mode

LSB						MSB
-----	--	--	--	--	--	-----

Preamble (4~16 octet)	SFD (1 octet)	Frame Length (1 octet)	PSDU (Variable 0~127 octets)	CRC (2 octets)
SHR		PHR	PHY Payload	

Packet format in 2.4 GHz proprietary mode is shown in table below:

Table 6-5 Packet Format in Proprietary Mode

LSB/MSB		MSB/LSB	
Preamble (configurable 8 octet)	Access Address (configurable 2~5 bytes)	Packet Controller + Payload (1~33 bytes)	CRC (1~2 bytes)

Packet format of Basic Rate Packet is shown in table below.

Table 6-6 Packet Format of Basic Rate Packets

LSB 68/72	54	0~2790	MSB
Preamble	Access Code	Header	Payload

Packet format of Enhanced Data Rate Packets is shown in table below.

Table 6-7 Packet Format of Enhanced Data Rate Packet

LSB					MSB	
Preamble	Access Code	Header	Guard	SYNC	Enhanced Data Rate Payload	Trailer
GFSK				DPSK		

6.3.2 BLE Location Function

In BLE 1M or 2M mode, BLE location features including AoA (Angle of Arrival) and AoD (Angle of Departure) are supported.

In the location mode of operation, the chip transmits a training sequence concatenated to the normal packet transmissions. In AoA mode of operation, the receiving side has multiple antennas and will be switched during the training sequence period. In AoD mode of operation, the transmitting side has multiple antennas and will be switched during the training sequence period. In either mode, the receiving side will be able to determine based on the phase variations of the received training sequences, the angle of location of the peer device.

6.3.3 RSSI and Frequency Offset

The SoC provides accurate RSSI (Receiver Signal Strength Indicator) and frequency offset indication.

- RSSI can be read from the 1 byte at the tail of each received data packet.

- If no data packet is received (e.g. to perform channel energy measurement when no desired signal is present), real-time RSSI can also be read from specific registers which will be updated automatically.
- RSSI monitoring resolution can reach +/-1 dB.
- Frequency offset can be read from the 2 bytes at the tail of the data packet. Valid bits of actual frequency offset may be less than 16 bits, and different valid bits correspond to different tolerance range.

Telink supplies corresponding drivers for user to read RSSI and frequency offset as needed.

7 Clock

7.1 Clock Sources

The SoC's clock sources are a 24 MHz RC oscillator and an external 24 MHz crystal, as shown below.

Figure 7-1 Clock Sources

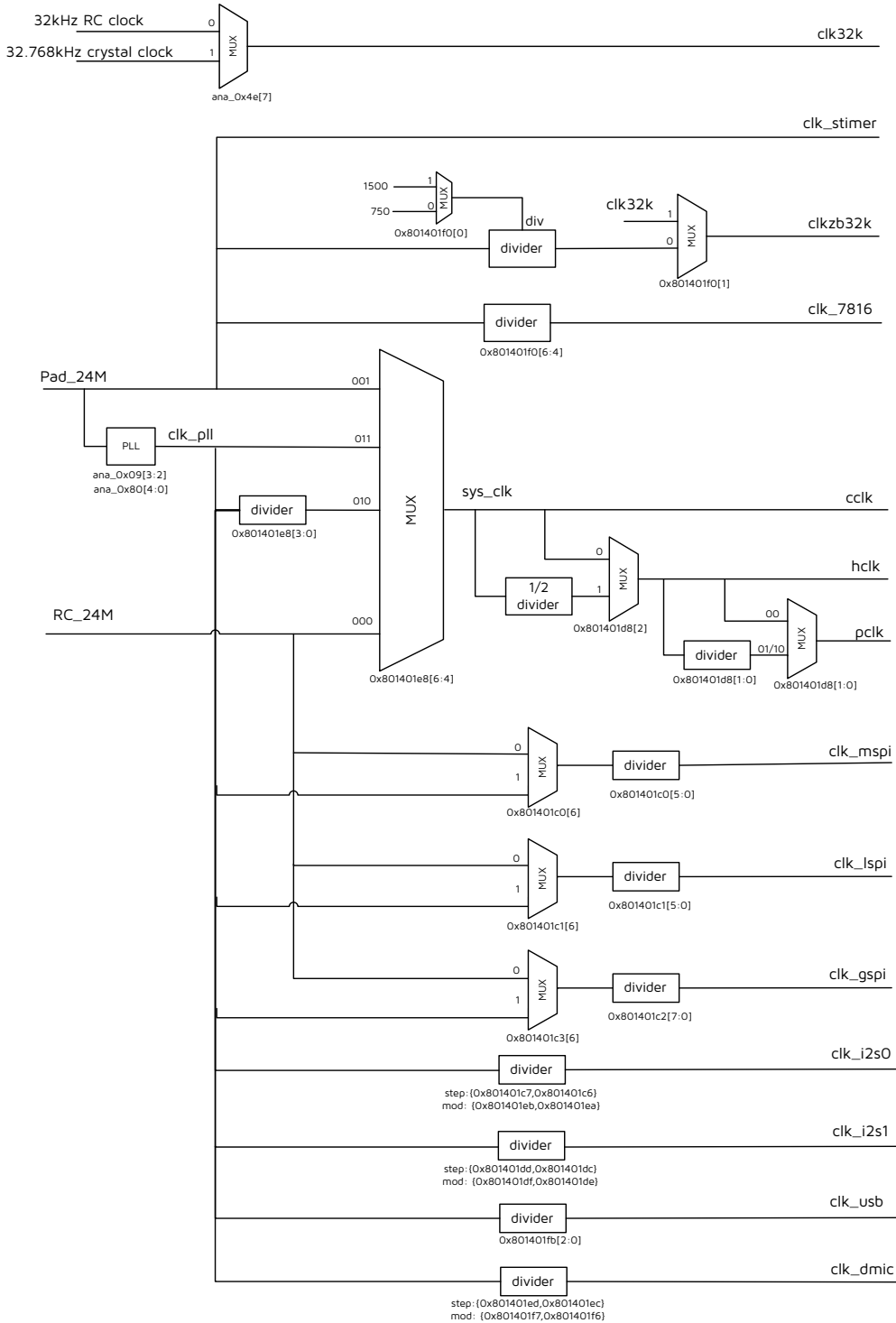

NOTE: The maximum frequency supported by cclk is 96 MHz.

The clock sources of each module are shown in table below.

Table 7-1 Clock Sources of Each Module

Module	Clock Source(s)
HSPI	hclk
PLMT	clk32k, hclk
PLIC	hclk
MCU	cclk
ILM	cclk
DLM	cclk
MSPI	hclk, clk_mspi
GSPI	hclk, clk_gspi
LSPI	hclk, clk_lspi
ZB	clkzb32k, hclk
AUDIO	hclk, pclk, clk_i2s, clk_dmic
PKE	hclk
TRNG	hclk
SWIRE	hclk
USB	hclk, clk_usb
DMA	hclk
BMC	hclk
I2C	pclk
PWM	pclk, clk32k
GPIO	pclk
QDEC	pclk
STIMER	pclk, clk32k, clk_stimer
ALGM	pclk
TIMER	pclk
UART1	pclk

Module	Clock Source(s)
UART0	pclk
SPI_SLV	hclk

7.2 System Clock

There are four selectable clock sources for MCU system clock: RC_24M derived from 24 MHz RC oscillator, 24 MHz crystal, sclk_div, and pll clk. The sources are selectable via register CLKSELO.

7.3 Module Clock

Registers CLKENO–CLKEN3 are used to enable or disable clock for various modules. By disable the clocks of unused modules, current consumption could be reduced.

7.3.1 System Timer Clock

System timer clock is derived from 24 MHz crystal oscillator.

7.3.2 USB Clock

USB clock is generated by pll_clk via frequency divider, the frequency is calculated with the following equations:

$$F_{clk_usb} = F_{pllclk}/n \quad (n=0x801401fb[2:0], n=1\sim7)$$

7.3.3 I2S0 Clock

I2S0 clock is generated by pll_clk via frequency divider. Register I2S0_STEP_H[7] should be set as 1'b1 to enable I2S0 clock. I2S0 clock frequency dividing factor contains step and mod.

Registers I2S0_STEP_H[6:0], I2S0_STEP_L[7:0], I2S0_MOD_H[7:0] and I2S0_MOD_L[7:0] serve to set I2S0 clock step[14:0] and mod[15:0] respectively, and mod should be no less than 2*step.

I2S0 clock frequency, F_{i2s0_clock} , equals to $pllclk * I2S0_step[14:0] / I2S0_mod[15:0]$.

7.3.4 I2S1 Clock

I2S1 clock is generated by pll_clk via frequency divider. Register I2S1_STEP_H[7] should be set as 1'b1 to enable I2S1 clock. I2S1 clock frequency dividing factor contains step and mod.

Registers I2S1_STEP_H[6:0], I2S1_STEP_L[7:0], I2S1_MOD_H[7:0] and I2S1_MOD_L[7:0] serve to set I2S1 clock step[14:0] and mod[15:0] respectively, and mod should be no less than 2*step.

I2S1 clock frequency, F_{i2s1_clock} , equals to $pllclk * I2S1_step[14:0] / I2S1_mod[15:0]$.

7.3.5 DMIC Clock

DMIC clock is generated by pll_clk via frequency divider. Register DMIC_STEP_H[7] should be set as 1'b1 to enable DMIC clock. DMIC clock frequency dividing factor contains step and mod.

Registers DMIC_STEP_H[6:0], DMIC_STEP_L[7:0], DMIC_MOD_H[7:0] and DMIC_MOD_L[7:0] serve to set DMIC clock step[14:0] and mod[15:0] respectively, and mod should be no less than 2*step.

DMIC clock frequency, F_{dmic_clock}, equals to pllclk*DMIC_step[14:0]/DMIC_mod[15:0].

7.3.6 clkzb32k

When CLK_DIV[0] = 1, F_{clkzb32k}=F_{pad_24m}/1500; when CLK_DIV[0] = 0, F_{clkzb32k}=F_{pad_24m}/700; when register CLK_DIV[1] = 1, clkzb32k chooses clk32k, when CLK_DIV[1] = 0, clkzb32 chooses the clock generated by pad_24M via a frequency divider.

7.3.7 clk_7816

F_{clk_7816} = F_{pad_24m}/n (n=CLK_DIV[6:4], n=2~7)

F_{clk_7816} = F_{pad_24m}/16 (n=CLK_DIV[6:4], n=0)

7.3.8 clk_msppi

The clk_msppi is the system clock of MSPI module. The default value of CLKSELO[7] is 1, and clk_msppi chooses sys_clk.

If MSPI_MODE[6] = 1, F_{clk_msppi} = F_{pllclk}/n (n=MSPI_MODE[5:0], n=1~63);

If MSPI_MODE[6] = 0, F_{clk_msppi} = F_{24M}/n (n=MSPI_MODE[5:0], n=1~63).

7.3.9 clk_lsppi

If LSPI_MODE[6] = 1, F_{clk_lsppi} = F_{pllclk}/n (n=LSPI_MODE[5:0], n=1~63);

If LSPI_MODE[6] = 0, F_{clk_lsppi} = F_{24M}/n (n=LSPI_MODE[5:0], n=1~63).

7.3.10 clk_gsppi

If GSPI_MODE_H[6] = 1, F_{clk_gsppi} = F_{pllclk}/n (n=GSPI_MODE_L[7:0], n=1~255);

If GSPI_MODE_H[6] = 0, F_{clk_gsppi} = F_{24M}/n (n=GSPI_MODE_L[7:0], n=1~255).

7.4 Register Table

Clock related registers are listed in table below. The base address of the following registers is 0x801401c0.

Table 7-2 Clock Related Registers

Address Offset	Type	Description	Reset Value
0x12	R/W	CLKMOD [3:0]: zb_mst_mod, zb master clock divider mod output clk is 1/(zb_mst_mod+1)	0x03

Address Offset	Type	Description	Reset Value
0x24	R/W	CLKEN0 [0]: lspi [1]: i2c [2]: uart0 [3]: usb [4]: pwm [5]: rsvd [6]: uart1 [7]: swires	0xa0
0x25	R/W	CLKEN1 [0]: rsvd [1]: stimer [2]: dma [3]: algm [4]: pke [5]: machinetime [6]: gspi [7]: spislv	0xa0
0x26	R/W	CLKEN2 [0]: timer [1]: audio [2]: i2c1 [3]: rsvd [4]: mcu [5]: lm [6]: trng [7]: dpr	0x30

Address Offset	Type	Description	Reset Value
0x27	R/W	CLKEN3 [0]:zb_pclk [1]:zb_mstclk [2]:zb_lpclk [3]: rsvd [4]:mspi [5]:qdec [6]:rsvd2 [7]:rsvd3	0x10
0x28	R/W	CLKSELO [3:0]:sclk_div [6:4]:sclk_sel, 000:24M_rc, 001:24M_xtal, 010:sclk_div, 011:pll clk	0x02
0x2a	R/W	I2S0_MOD_L [7:0]: i2s0_mod_l	0x02
0x2b	R/W	I2S0_MOD_H [7:0]: i2s0_mod_h	0x00
0x2c	R/W	DMIC_STEP_L [7:0]:dmic_step_l	0x01
0x2d	R/W	DMIC_STEP_H [6:0]:dmic_step_h [7]: dmic_clk_sel	0x00
0x2e	R/W	WAKEUPEN [0]: usb_pwdn_i, enable wakeup from usb [1]: gpio_wakeup_i, enable wakeup from gpio [2]: qdec_wakeup_i, enable wakeup from qdec [4]: usb resume, enable remote wakeup from USB [5]: standby ex [7:6]: reserved	0x00

Address Offset	Type	Description	Reset Value
0x2f	R/W	PWDNEN [0]: suspend_en_o [4]: ramcrc_clren_tgl [5]: rst_all [7]: stall_en_trg	0x00
0x30	R/W	CLK_DIV [0:2]: clkzb32k_sel [6:4]: r_7816_mod, 7816 clk div [7]: r_7816_clk_en, 7816 clk enable	0x62

8 Timer

8.1 Timer0 ~ Timer1

The SoC supports two timers: Timer0 ~ Timer1. Timer0 and Timer1 support four modes: Mode 0 (System Clock Mode), Mode 1 (GPIO Trigger Mode), Mode 2 (GPIO Pulse Width Mode) and Mode 3 (Tick Mode), which are selectable via the register TMR_CTRL0 (address 0x80140140).

8.1.1 Mode 0 (System Clock Mode)

In Mode 0, system clock is employed as clock source.

After Timer is enabled, Timer Tick (i.e. counting value) is increased by 1 on each positive edge of system clock from preset initial Tick value. Generally the initial Tick value is set to 0.

Once current Timer Tick value matches the preset Timer Capture (i.e. timing value), an interrupt is generated, Timer stops counting and Timer status is updated.

Steps of setting Timer0 for Mode 0 is taken as an example.

Step 1 Set initial Tick value of Timer0

Set Initial value of Tick via registers TMR_TICK0_0~TMR_TICK0_3, from lowest byte to highest byte respectively. It's recommended to clear initial Timer Tick value to 0.

Step 2 Set Capture value of Timer0

Set registers TMR_CAPTO_0~TMR_CAPTO_3, from lowest byte to highest byte respectively.

Step 3 Set Timer0 to Mode 0 and enable Timer0

Set register TMR_CTRL0 [2:1] to 2'b00 to select Mode 0; Meanwhile set TMR_CTRL0 [0] to 1'b1 to enable Timer0. Timer0 starts counting upward, and Tick value is increased by 1 on each positive edge of system clock until it reaches Timer0 Capture value.

8.1.2 Mode 1 (GPIO Trigger Mode)

In Mode 1, GPIO is employed as clock source. The "M0"/"M1"/"M2" register specifies the GPIO which generates counting signal for Timer0/Timer1/Timer2.

After Timer is enabled, Timer Tick (i.e. counting value) is increased by 1 on each positive/negative (configurable) edge of GPIO from preset initial Tick value. Generally the initial Tick value is set to 0. The "Polarity" register specifies the GPIO edge when Timer Tick counting increases.

Once current Timer Tick value matches the preset Timer Capture (i.e. timing value), an interrupt is generated and timer stops counting.

Steps of setting Timer1 for Mode 1 is taken as an example.

Step 1 Set initial Tick value of Timer1

Set Initial value of Tick via registers TMR_TICK1_0~TMR_TICK1_3, from lowest byte to highest byte respectively. It's recommended to clear initial Timer Tick value to 0.

Step 2 Set Capture value of Timer1

Set registers TMR_CAPT1_0~TMR_CAPT1_3, from lowest byte to highest byte respectively.

Step 3 Select GPIO source and edge for Timer1

Select certain GPIO to be the clock source via setting "M1" register.

Select positive edge or negative edge of GPIO input to trigger Timer1 Tick increment via setting "Polarity" register.

Step 4 Set Timer1 to Mode 1 and enable Timer1

Set TMR_CTRL0 [5:4] to 2'b01 to select Mode 1; Meanwhile set TMR_CTRL0 [3] to 1'b1 to enable Timer1. Timer1 starts counting upward, and Timer1 Tick value is increased by 1 on each positive/negative (specified during the 3rd step) edge of GPIO until it reaches Timer1 Capture value.

8.1.3 Mode 2 (GPIO Pulse Width Mode)

In Mode 2, system clock is employed as the unit to measure the width of GPIO pulse. The "M0"/"M1"/"M2" register specifies the GPIO which generates control signal for Timer0/Timer1/Timer2.

After Timer is enabled, Timer Tick is triggered by a positive/negative (configurable) edge of GPIO pulse. Then Timer Tick (i.e. counting value) is increased by 1 on each positive edge of system clock from preset initial Tick value. Generally the initial Tick value is set to 0. The "Polarity" register specifies the GPIO edge when Timer Tick starts counting.

While a negative/positive edge of GPIO pulse is detected, an interrupt is generated and timer stops counting. The GPIO pulse width could be calculated in terms of tick count and period of system clock.

Steps of setting Timer1 for Mode 2 is taken as an example.

Step 1 Set initial Timer1 Tick value

Set Initial value of Tick via registers TMR_TICK1_0~TMR_TICK1_3, from lowest byte to highest byte respectively. It's recommended to clear initial Timer Tick value to 0.

Step 2 Select GPIO source and edge for Timer1

Select certain GPIO to be the clock source via setting "M1" register.

Select positive edge or negative edge of GPIO input to trigger Timer2 counting start via setting "Polarity" register.

Step 3 Set Timer2 to Mode 2 and enable Timer1

Timer1 Tick is triggered by a positive/negative (specified during the 2nd step) edge of GPIO pulse. Timer1 starts counting upward and Timer1 Tick value is increased by 1 on each positive edge of system clock.

While a negative/positive edge of GPIO pulse is detected, an interrupt is generated and Timer1 tick stops.

Step 4 Read current Timer1 Tick value to calculate GPIO pulse width

Read current Timer1 Tick value.

Then GPIO pulse width is calculated as follows:

GPIO Pulse Width = System Clock Period *(Current Timer1 Tick - Initial Timer1 Tick)

For initial Timer1 Tick value is set to the recommended value of 0, then:

GPIO Pulse Width = System Clock Period * Current Timer1 Tick

8.1.4 Mode 3 (Tick Mode)

In Mode 3, system clock is employed.

After Timer is enabled, Timer Tick starts counting upward, and Timer Tick value is increased by 1 on each positive edge of system clock.

This mode could be used as time indicator. There will be no interrupt generated. Timer Tick keeps rolling from 0 to 0xffffffff. When Timer tick overflows, it returns to 0 and starts counting upward again.

Steps of setting Timer0 for Mode 3 is taken as an example.

Step 1 Set initial Tick value of Timer0

Set Initial value of Tick via TMR_TICKO_1 ~TMR_TICKO_3, from lowest byte to highest byte respectively.

Step 2 Set Timer0 to Mode 3 and enable Timer0

Set TMR_CTRL0 [2:1] to 2'b11 to select Mode 3, meanwhile set address TMR_CTRL0 [0] to 1'b1 to enable Timer0. Timer0 Tick starts to roll.

Step 3 Read current Timer0 Tick value

Current Timer0 Tick value can be read from TMR_TICKO_1 ~TMR_TICKO_3.

8.1.5 Watchdog

Programmable watchdog could reset chip from unexpected hang up or malfunction.

Watchdog Capture has 24bits, which consists of WT_TARGET_1~WT_TARGET_3 as byte 1 ~byte 3. Chip will be reset when TMR_CTRL3[2] is set to 1.

Step 1 Set WT_TARGET_1~WT_TARGET_3

Set registers WT_TARGET_1~WT_TARGET_3, from lowest byte to highest byte respectively.

Step 2 Enable Watchdog

Set TMR_CTRL2[7] to 1'b1 to enable Watchdog.

During normal working condition, TMR_CTRL3[3] need write 1 to clean the watchdog before the watchdog hits WT_TARGET3-1, or it will reboot the whole chip, and the TMR_CTRL3[2] will be assert to 1, this bit will be clean when write 1.

8.1.6 Register Table

Timer related register are listed in table below. The base address for the following registers is 0x80140140.

Table 8-1 Registers for Timer 0 ~ Timer 1

Offset	Type	Description	Reset Value
0x00	R/W	TMR_CTRL0 [1:0] tmr0m_sel, 0:tmr0m0,using pclk 1:tmr0m1, count gpio2risc0 posedge 2:tmr0m2 count gpio2risc0 high width 3:tmr0m3,tick [2] tmren0, Timer0 enable [3] tm0_nowrap, Timer0 nowrap [5:4] tmr1m_sel, 0:tmr1m0,using pclk 1:tmr1m1, count gpio2risc1 posedge 2:tmr1m2 count gpio2risc1 high width 3:tmr1m3,tick [6] tmren1, Timer2 enable [7] tm1_nowrap, Timer1 nowrap	0x0
0x02	R/W	TMR_CTRL2 [6:0] reserved [7] watchdog_en	0x0
0x03	R/W	TMR_CTRL3 [0] tmr0, tmr0_o=tmr0 [1] tmr1, tmr1_o=tmr1 [2] wdstat, hit watchdog target [3] wd_cnt_clr, clear wd_cnt [6:4] reserved [7] software_irq	0x0
0x04	R/W	TMR_CAPTO_0 capt0[7:0] Byte 0 of timer0 capture	0x0
0x05	R/W	TMR_CAPTO_1 capt0[15:8] Byte 1 of timer0 capture	0x0
0x06	R/W	TMR_CAPTO_2 capt0[23:16] Byte 2 of timer0 capture	0x0
0x07	R/W	TMR_CAPTO_3 capt0[31:24] Byte 3 of timer0 capture	0x0
0x08	R/W	TMR_CAPT1_0 capt1[7:0] Byte 0 of timer1 capture	0x0

Offset	Type	Description	Reset Value
0x09	R/W	TMR_CAPT1_1 capt1[15:8] Byte 1 of timer1 capture	0x0
0x0a	R/W	TMR_CAPT1_2 capt1[23:16] Byte 2 of timer1 capture	0x0
0x0b	R/W	TMR_CAPT1_3 capt1[31:24] Byte 3 of timer1 capture	0x0
0x0d	R/W	WT_TARGET_1 watchdog_target2[15:8] Byte 1 of watchdog target value	0x0
0x0e	R/W	WT_TARGET_2 watchdog_target2[23:16] Byte 2 of watchdog target value	0x0
0x0f	R/W	WT_TARGET_3 watchdog_target2[31:24] Byte 3 of watchdog target value	0x0
0x10	R/W	TMR_TICK0_0 tick0[7:0] Byte 0 of timer0 ticker	0x0
0x11	R/W	TMR_TICK0_1 tick0[15:8] Byte 1 of timer0 ticker	0x0
0x12	R/W	TMR_TICK0_2 tick0[23:16] Byte 2 of timer0 ticker	0x0
0x13	R/W	TMR_TICK0_3 tick0[31:24] Byte 3 of timer0 ticker	0x0
0x14	R/W	TMR_TICK1_0 tick1[7:0] Byte 0 of timer1 ticker	0x0
0x15	R/W	TMR_TICK1_1 tick1[15:8] Byte 1 of timer1 ticker	0x0
0x16	R/W	TMR_TICK1_2 tick1[23:16] Byte 2 of timer1 ticker	0x0
0x17	R/W	TMR_TICK1_3 tick1[31:24] Byte 3 of timer1 ticker	0x0

8.2 32K LTimer

The SoC also supports a low frequency (32 kHz) LTIMER in suspend mode or deep sleep mode. This timer can be used as one kind of wakeup source.

In order to avoid the situation of not being able to wake up in low power mode and power on error, a new watch dog function has been added to the 32 kHz timer. And the watch dog function is enabled by default.

The corresponding register configuration is as follows.

Table 8-2 32K LTimer Related Registers

Address	Name	Description	Default Value
afe_0x64	status	write 1 to clean the status: [0]:wkup pad [1]:wkup dig [2]:wkup timer [3]:wkup cmp [4]:wkup mdec [5]:rsvd [6]:wkup vad [7]:watch_dog	-
afe_0x79	ltimer_watchdog_en	[0]: ltimer_watchdog_en [3:1] rsvd [7:4] rsvd, ltimer_watchdog_v[7:0] is 0x0	1
afe_0x7a	ltimer_watchdog_v[15:8]	[7:0] ltimer_watchdog_v[15:8]	01110001
afe_0x7b	ltimer_watchdog_v[23:16]	[7:0] ltimer_watchdog_v[23:16]	00000010
afe_0x7c	ltimer_watchdog_v[31:24]	[7:0] ltimer_watchdog_v[31:24]	0

The afe_0x79[0] is the watch dog enable signal, write 1 to enable the watch dog function.

The afe_0x7a to afe_0x7c combined into ltimer_watchdog_v[31:8] is the target value corresponding to the 32k timer reset for the entire system. The default value is 0x271, which is 0x27100 for 32k cycle, corresponding to 5 seconds. (After power up, if the firmware does not modify this value in time, it will reset the whole system after 5 seconds).

The afe_0x64[7] is the status of watch dog, write 1 to clear the status.

The difference between this watch dog and the regular watch dog is that clearing the dog is achieved by modifying the ltimer_watchdog_v value. Because the 32k timer is reused, the calculator keeps adding until the count reaches the maximum value and then continues from 0. When modifying the value, the enable signal needs to be disabled first.

8.3 System Timer

The SoC also supports a System Timer, the clock frequency for System Timer is fixed as 24 MHz irrespective of system clock.

In suspend mode, both System Timer and Timer0 ~ Timer1 stop counting, and 32K Timer starts counting. When the chip restores to active mode, Timer0 ~ Timer1 will continue counting from the number when they stops; In contrast, System Timer will continue counting from an adjusted number which is a sum of the number when it stops and an offset calculated from the counting value of 32K Timer during suspend mode.

System timer related registers are listed in table below. The base address for the registers is 0x80140200.

Table 8-3 System Timer Related Registers

Offset	Type	Description	Reset Value
0x00	R/W	SYS_TIMER0	0x00
0x01	R/W	SYS_TIMER1	0x00
0x02	R/W	SYS_TIMER2	0x00
0x03	R/W	SYS_TIMER3	0x00
0x0a	R/W	SYS_TIMER_CTRL [0] wr_32k, 1:32k write mode; 0:32k read mode [1] timer_en, system timer enable [2] timer_auto [3] cal_32k_en, 32k calibration enable [7:4] cal_32k_mode, 32k calibration mode ($2^{(16 - \text{cal_32k_mode})}$) cycles of 32k clock	0xc1
0x0b	R/W	SYS_TIMER_ST [1] cmd_stop, write 1, stop system timer when using auto mode [3] cmd_sync, write 1, start 32k count write; R:st_list3(wr_busy) [4] clk_32k, 32k clock read [5] clr_rd_done, clear read 32k update flag; R:st_list5(rd_done) [6] rd_busy, 32k read busy status [7] cmd_set_dly_done, system timer set done status upon next 32k posedge	0x00

8.4 Platform-Level Machine Timer (PLMT)

8.4.1 Introduction

The RISC-V architecture defines a machine timer that provides a real-time counter and generates timer interrupts. Platform-Level Machine Timer (PLMT) is an implementation of the machine timer.

PLMT supports the following features:

- Supports 64-Bits mtime and mtimecmp
- Supports timer interrupt generation when $\text{mtime} \geq \text{mtimecmp}$

The PLMT block diagram is shown in the figure below.

Figure 8-1 Block Diagram of PLMT

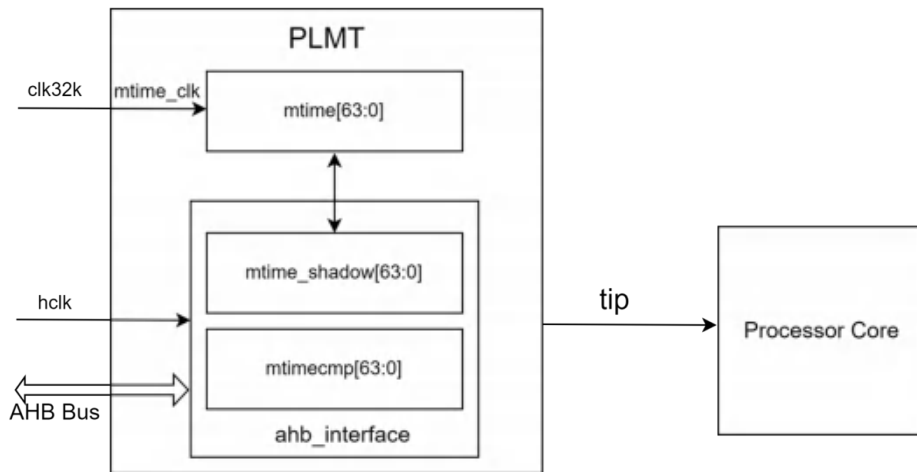

PLMT primarily consists of these memory-mapped registers: mtime and mtimecmp. The mtime register is a 64-bit real-time counter clocked by mtime_clk. The source of mtime_clk is clk32k.

The mtimecmp register stores a 64-bit value for comparing with mtime. When the value in mtime is greater than or equal to the value in mtimecmp, the mtip signal is asserted for generating a timer interrupt. When mtimecmp is written, the interrupt is cleared and the mtip signal is deasserted.

The mtime register is driven by mtime_clk, which is assumed to be slower than hclk. The mtime_shadow shadow register is maintained in the hclk domain to reduce the latency of accessing the mtime register in the slow clock domain. The values of mtime and mtime_shadow registers are constantly synchronized such that mtime_shadow maintains the most up-to-date values of mtime. The value in mtime_shadow is instantly returned when reading the mtime register. When writing the mtime register, bus write transactions finish when the values are written to the mtime_shadow register, and PLMT handles the synchronization to mtime in the background.

8.4.2 Access To Mtime

The mtime counter is a 64-bit value and it increments non-stop on every machine timer clock except the first few cycles after its control register updates. But it can only be accessed as two separate 32-bit registers by 32-bit width bus. So, please follow the following programming sequence to make sure the access to mtime is correct.

For Write Mtime sequence:

1. Write zero to mtime[31:0].
2. Write high part of the intended value to mtime[63:32].
3. Write low part of the intended value to mtime[31:0].

For Read Mtime sequence:

1. Read mtime[63:32] and save it to integer variable hi0.
2. Read mtime[31:0] and save it to integer variable lo0.
3. Read mtime[63:32] and save it to integer variable hi1.
4. If hi1 is not equal to hi0, jump to step 1. Otherwise, return $((\text{unsigned long long})\text{hi0} \ll 32) \mid \text{lo0}$;

8.4.3 Access To Mtimecmp

The mtimecmp register is a 64-bit value. But it can only be accessed as two separate 32-bit registers by 32-bit width bus. So, please follow the following programming sequence to avoid spuriously generating an interrupt due to the intermediate value of the mtimecmp register.

For Write Mtimecmp sequence:

1. Write 0xFFFFFFFF to mtimecmp[31:0].
2. Write high part of the intended value to mtimecmp[63:32].
3. Write low part of the intended value to mtimecmp[31:0].

8.4.4 Register Description

PLMT related registers are listed in table below. The base address for the following registers is 0xE6000000.

Please note that PLMT supports only 32-bit. Behaviors of 8-bit and 16-bit transfers are UNDEFINED, and these transfers might be ignored as well as result in error responses or unexpected register updates.

Table 8-4 PLMT Related Registers

Offset	Name	Type	Description	Reset Value
0x00	mtime_low	R/W	low part of mtime [31:0]: mtime[31:0]	0x00
0x04	mtime_high	R/W	high part of mtime [31:0]: mtime[63:32]	0x00
0x08	mtimecmp_low	R/W	low part of mtimecmp [31:0]: mtimecmp[31:0]	0xFFFFFFFF
0x0c	mtimecmp_high	R/W	high part of mtimecmp [31:0]: mtimecmp[63:32]	0xFFFFFFFF

9 Trap and PLIC

9.1 Trap

9.1.1 Introduction

According to the RISC-V Privileged Architecture, a trap is a control flow change of normal instruction execution caused by an interrupt or an exception. An interrupt is a control flow change event initiated by an external source. An exception is a control flow change event generated as a by-product of instruction execution. When a trap happens, the processor stops processing the current flow of instructions, disables interrupts, saves enough states for later resumption, and starts executing a trap handler.

Interrupts can be local or external. The external interrupts are global interrupts that are arbitrated externally by a platform level interrupt controller (PLIC) and the selected external interrupt joins the rest of local interrupts for arbitration to take a trap.

For exceptions, mepc is the PC (Program Counter) of the faulting instruction. For Interrupts, mepc is pointing to the interrupted instruction.

9.1.2 Interrupt

Figure 9-1 Block Diagram of Interrupt

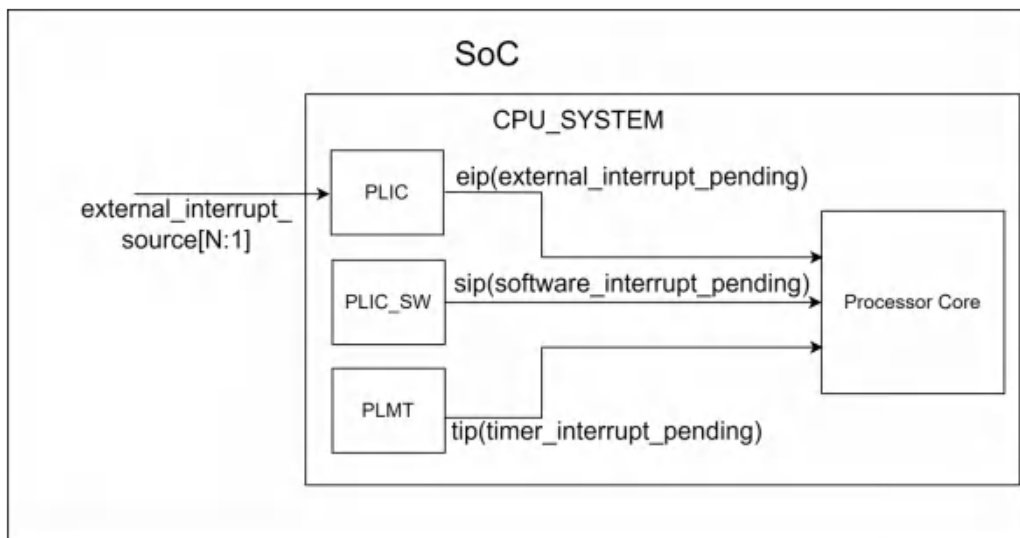

As shown in the above figure, the processor provides three interrupt inputs: platform-level machine timer (PLMT) interrupt, software platform-level interrupt controller (PLIC_SW) interrupt, and platform-level interrupt controller (PLIC) interrupt.

The PLMT interrupt and PLIC_SW interrupt are local interrupts. External interrupts are arbitrated and distributed by PLIC to the processor. Each external interrupt source can be assigned its own priority, and the processor core could select which external interrupt sources it would handle. PLIC routes the highest priority interrupt source to the target processor.

9.1.2.1 Local Interrupts

In addition to external interrupts, the processor may generate internal interrupts for the following events:

- Bus read/write transaction error
- Performance monitor overflow

9.1.2.2 Interrupt Status and Masking

The mip CSR (Control and Status Register of the processor core) contains pending bits of these interrupts, with the mie CSR contains enable bits of the respective interrupts. The processor can selectively enable interrupts by manipulating the mie CSR, or globally disable interrupts by clearing the mstatus.MIE bit.

9.1.2.3 Interrupt Priority

When multiple interrupts are taken at the same time, they are handled under the following order:

Table 9-1 Interrupt Priority

Priority	Interrupt
High	M-mode performance monitor overflow interrupt
↓	M-mode bus read/write transaction error interrupt
	M-mode external interrupt (MEI)
	M-mode software interrupt (MSI)
Low	M-mode timer interrupt (MTI)

9.1.3 Exception

The processor implements the following exceptions.

- Instruction address misaligned exceptions
 - Jump to misaligned addresses
- Instruction access faults
 - Bus errors caused by instruction fetches
- Illegal instructions
 - Unsupported instructions
 - Privileged instructions
 - Accessing non-existent CSRs (Control and Status Registers of the processor core)
 - Accessing privileged CSRs
 - Writing to read-only CSRs
- Breakpoint exceptions
- Load address misaligned exceptions
- Load access faults
 - Bus errors caused by load instructions
- Store/AMO (atomic memory operation) address misaligned exceptions
- Store/AMO access faults
- Environment calls
- Stack overflow/underflow exceptions

9.1.4 Trap Handling

9.1.4.1 Entering the Trap Handler

When a trap occurs, the following operations are applied:

- mepc is set to the current program counter.
- mstatus is updated.
 - The MPP field is set to the current privilege mode.
 - The MPIE field is set to the MIE field.
 - The MIE field is set to 0.
- mcause is updated.
- mtval is updated on any of address-misaligned or access-fault exceptions.
- The privilege mode is changed to M-mode.
- When mmisc_ctl.VEC_PLIC is 0, the program counter is set to the address specified by mtvec.
- When mmisc_ctl.VEC_PLIC is 1, the mtvec register will be the base address register of a vector table with 4-byte entries storing addresses pointing to interrupt service routines.
 - mtvec[0] is for exceptions and non-external local interrupts. For these traps, the mcause register records the trap type based on RISC-V definitions.
 - mtvec[i] is for external PLIC interrupt source i triggered through the mip.MEIP pending condition.

9.1.4.2 Returning from the Trap Handler

After handling a trap, the MRET instruction can be executed for returning to the instruction and the privilege context before the trap happened. Alternatively, the trap handler could assign new PC, privilege level and/or interrupt enable status to mepc, mstatus.MPP and mstatus.MPIE before MRET. Specifically, the following operations take place when an MRET instruction is executed:

- The program counter is set to mepc.
- The privilege mode is set to mstatus.MPP.
- mstatus is updated.
 - The MPP field is set to U-mode.
 - The MIE field is set to the MPIE field.
 - The MPIE field is set to 1.

9.1.5 Machine Trap Related CSRs

9.1.5.1 Machine Status

Mnemonic Name: mstatus

Access Mode: Machine

CSR Address: 0x300

Table 9-2 Register Description of mstatus

Name	Bits	Type	Description	Reset
MIE	[3]	R/W	M-mode interrupt enable bit.	0
MPIE	[7]	R/W	MPIE holds the value of the MIE bit prior to a trap.	0
MPP	[12:11]	R/W	MPP holds the privilege mode prior to a trap. 0: User mode 1: Reserved 2: Reserved 3: Machine mode	3

9.1.5.2 Machine Interrupt Enable

Mnemonic Name: mie

Access Mode: Machine

CSR Address: 0x304

Table 9-3 Register Description of mie

Name	Bits	Type	Description	Reset
MSIE	[3]	R/W	M-mode software interrupt enable bit.	0
MTIE	[7]	R/W	M-mode timer interrupt enable bit.	0
MEIE	[11]	R/W	M-mode external interrupt enable bit.	0
BWEI	[17]	R/W	Bus write transaction error local interrupt enable bit. The processor may receive bus errors on store instructions or cache writebacks.	0
PMOVI	[18]	R/W	Performance monitor overflow local interrupt enable bit.	0

9.1.5.3 Machine Trap Vector Base Address

Mnemonic Name: mtvec

Access Mode: Machine

CSR Address: 0x305

This register determines the base address of the trap vector. The least significant 2 bits are hardwired to zeros. When `mmisc_ctl.VEC_PLIC` is 0 (PLIC is not in the vector mode), this register indicates the entry points for the trap handler and it may point to any 4-byte aligned location in the memory space.

On the other hand, when `mmisc_ctl.VEC_PLIC` is 1 (PLIC is in the vector mode), this register will be the base address of a vector table with 4-byte entries storing addresses pointing to interrupt service routines.

- This register should be aligned to 256-byte boundary.
- `mtvec[0]` is for exceptions, local interrupts.

- mtvec[i] is for external PLIC interrupt source i triggered through the mip.MEIP pending condition

Table 9-4 Register Description of mtvec

Name	Bits	Type	Description	Reset
Base[31:2]	[31:2]	R/W	Base address for interrupt and exception handlers.	0

9.1.5.4 Machine Exception Program Counter

Mnemonic Name: mepc

Access Mode: Machine

CSR Address: 0x341

This register is written with the virtual address of the instruction that encountered traps when these events occurred.

Table 9-5 Register Description of mepc

Name	Bits	Type	Description	Reset
EPC	[31:0]	R/W	Exception program counter. Bit[0] is hardwired to zero.	0

9.1.5.5 Machine Cause Register

Mnemonic Name: mcause

Access Mode: Machine

CSR Address: 0x342

This register indicates the cause of trap, reset or the interrupt source ID of a vector interrupt. This register is updated when a trap, reset or vector interrupt occurs. When multiple events may cause a trap to be taken with the same mcause value, the value of mdcause records the exact event that causes the trap.

Table 9-6 Register Description of mcause

Name	Bits	Type	Description	Reset
Exception_code	[11:0]	R/W	Exception code	0
Interrupt	[31]	R/W	Interrupt	0

The following table shows the possible values of mcause:

Table 9-7 Possible Values of mcause

Interrupt	Exception Code	Description
1	3	Machine software interrupt
1	7	Machine timer interrupt
1	11	Machine non-vector external interrupt
1	17	Bus read/write transaction error interrupt (M-mode)

Interrupt	Exception Code	Description
1	18	Performance monitor overflow interrupt (M-mode)
0	0	Instruction address misaligned
0	1	Instruction access fault
0	2	Illegal instruction
0	3	Breakpoint
0	4	Load address misaligned
0	5	Load access fault
0	6	Store/AMO address misaligned
0	7	Store/AMO access fault
0	8	Environment call from U-mode
0	11	Environment call from M-mode
0	32	Stack overflow exception
0	33	Stack underflow exception

The following tables show the possible values of mcause after reset:

Table 9-8 Possible values of mcause after reset

Interrupt	Exception Code	Description
0	0	Initial value when the processor comes out of reset

The following tables show the possible values of mcause after vector interrupt:

Table 9-9 Possible values of mcause after vector interrupt

Interrupt	Exception Code	Description
0	Interrupt source ID	Interrupt source ID when a vector interrupt occurs

9.1.5.6 Machine Trap Value

Mnemonic Name: mtval

Access Mode: Machine

CSR Address: 0x343

This register is updated when a trap is taken to M-mode. The updated value is dependent on the cause of traps:

- For Hardware Breakpoint exceptions, Address Misaligned exceptions, or Access Fault exceptions, it is the effective faulting addresses.

- For illegal instruction exceptions, the updated value is the faulting instruction.
- For other exceptions, mtval is set to zero.

For instruction-fetch access faults, this register will be updated with the address pointing to the portion of the instruction that caused the fault, while the mepc register will be updated with the address pointing to the beginning of the instruction.

Table 9-10 Register Description of mtval

Name	Bits	Type	Description	Reset
mtval	[31:0]	R/W	Exception-specific information for software trap handling	0

9.1.5.7 Machine Interrupt Pending

Mnemonic Name: mip

Access Mode: Machine

CSR Address: 0x344

Table 9-11 Register Description of mip

Name	Bits	Type	Description	Reset
MSIP	[3]	RO	M-mode software interrupt pending bit.	0
MTIP	[7]	RO	M-mode timer interrupt pending bit.	0
MEIP	[11]	RO	M-mode external interrupt pending bit.	0
BWEI	[17]	R/W	Bus write transaction error local interrupt pending bit. The processor may receive bus errors on store instructions or cache writebacks.	0
PMOVI	[18]	R/W	Performance monitor overflow local interrupt pending bit.	0

9.1.5.8 Machine Detailed Trap Cause

Mnemonic Name: mdcause

Access Mode: Machine

CSR Address: 0x7c9

Table 9-12 Register Description of mdcause

Name	Bits	Type	Description	Reset
mdcause	[2:0]	R/W	This register further disambiguates causes of traps recorded in the mcause register. See the below for details.	0

Table 9-13 Detailed mdcause meaning in different mcause condition

mcause condition	mdcause value	Meaning
mcause == 1 (Instruction access fault)	0	Reserved
	1	Reserved
	2	PMP instruction access violation
	3	Reserved
	4	Reserved
mcause == 2 (Illegal instruction)	0	The actual faulting instruction is stored in the mtval CSR.
	1	FP (Floating-Point) disabled exception
mcause == 5 (Load access fault)	0	Reserved
	1	Reserved
	2	PMP load access violation
	3	Bus error
	4	Misaligned address
	5	Reserved
	6	Reserved
	7	Reserved
mcause == 7 (Store access fault)	0	Reserved
	1	Reserved
	2	PMP store access violation
	3	Bus error
	4	Misaligned address
	5	Reserved
	6	Reserved
	7	Reserved

9.1.5.9 Machine Miscellaneous Control Register

Mnemonic Name: mmisc_ctl

Access Mode: Machine

CSR Address: 0x7d0

Table 9-14 Register Description of mdcause

Name	Bits	Type	Description	Reset
VEC_PLIC	[1]	R/W	Select the operation mode of PLIC: 0: Non-Vector mode; 1: Vector mode; Please note that both this bit and PLIC_FEN.VECTORED in PLIC should be turned on for the vectored interrupt support to work correctly.	0

9.2 Platform-Level Interrupt Controller (PLIC)

9.2.1 Introduction

The SoC embeds a Platform-Level Interrupt Controller (PLIC) prioritizes and distributes global interrupts. It is compatible with RISC-V PLIC with the following features:

- Number of interrupts: 46
- Programmable interrupt priority: 1/2/3
- Preemptive priority interrupt extension
- Vectored interrupt extension
- Software-programmable interrupt generation

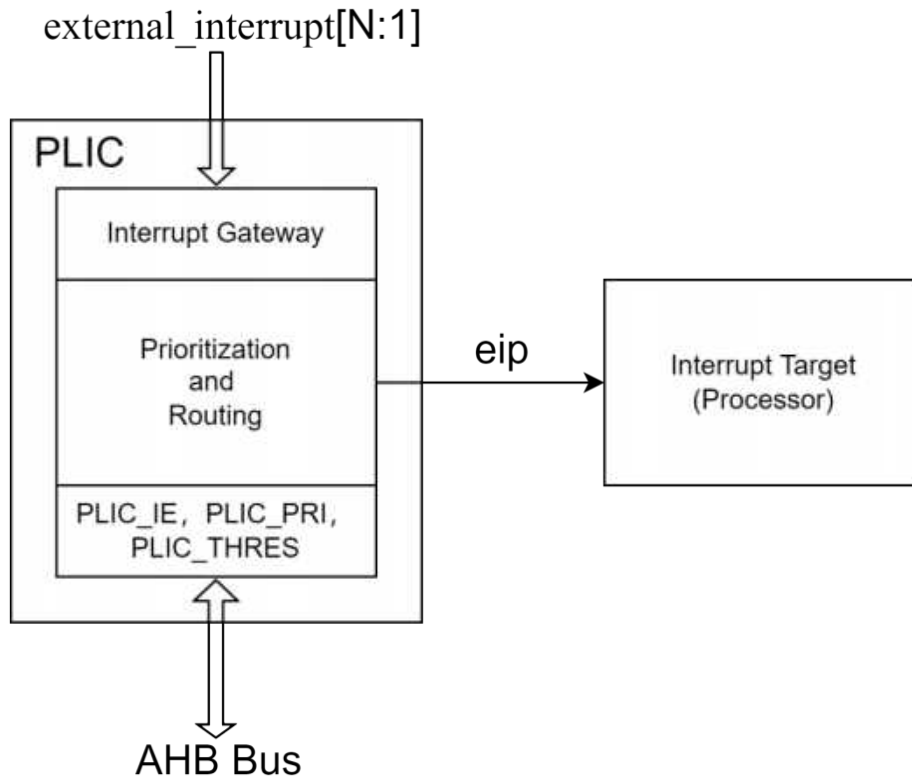
Figure 9-2 Block Diagram of PLIC

The above figure shows the block diagram of PLIC. External interrupt sources (e.g., peripherals) send interrupt requests to PLIC through external_interrupt[N:1] signals. The signals are level-triggered, and they are converted to interrupt requests by the interrupt gateway. Interrupt requests are prioritized and routed to interrupt targets (e.g., processor core) according to interrupt settings. Interrupt settings include enable bits (PLIC_IE), priorities (PLIC_PRI), and priority thresholds (PLIC_THRES), and these settings are programmable through the bus interface. Note that interrupt targets should not modify PLIC_IE, PLIC_PRI and PLIC_THRES if there are any un-serviced interrupts.

The eip is an external interrupt pending notification signal to the target. It is a level signal summarizing the interrupt pending status of all interrupt sources (PLIC_IP) to the target. When a target takes the external interrupt, it should send an interrupt claim request (bus read request) to retrieve the interrupt ID, upon which the corresponding PLIC_IP bit will be cleared and eip will be de-asserted. The eip is guaranteed to be de-asserted for at least one cycle even if there are pending interrupt sources still remaining. This is done to ensure that the interrupt detection logic of the target processor can see the remaining interrupt pending status.

The interrupt gateway stops processing newer interrupt requests from its interrupt sources once it reports an interrupt request. When the target has serviced the interrupt, it should send the interrupt completion message (bus write request) to PLIC such that the interrupt gateway resumes processing newer interrupt requests.

The PLIC_IP register provides a summary of all interrupt sources status. In addition, it is also writable for setting software-programmed interrupts for the corresponding interrupt sources.

Figure 9-3 Detailed Block Diagram of PLIC

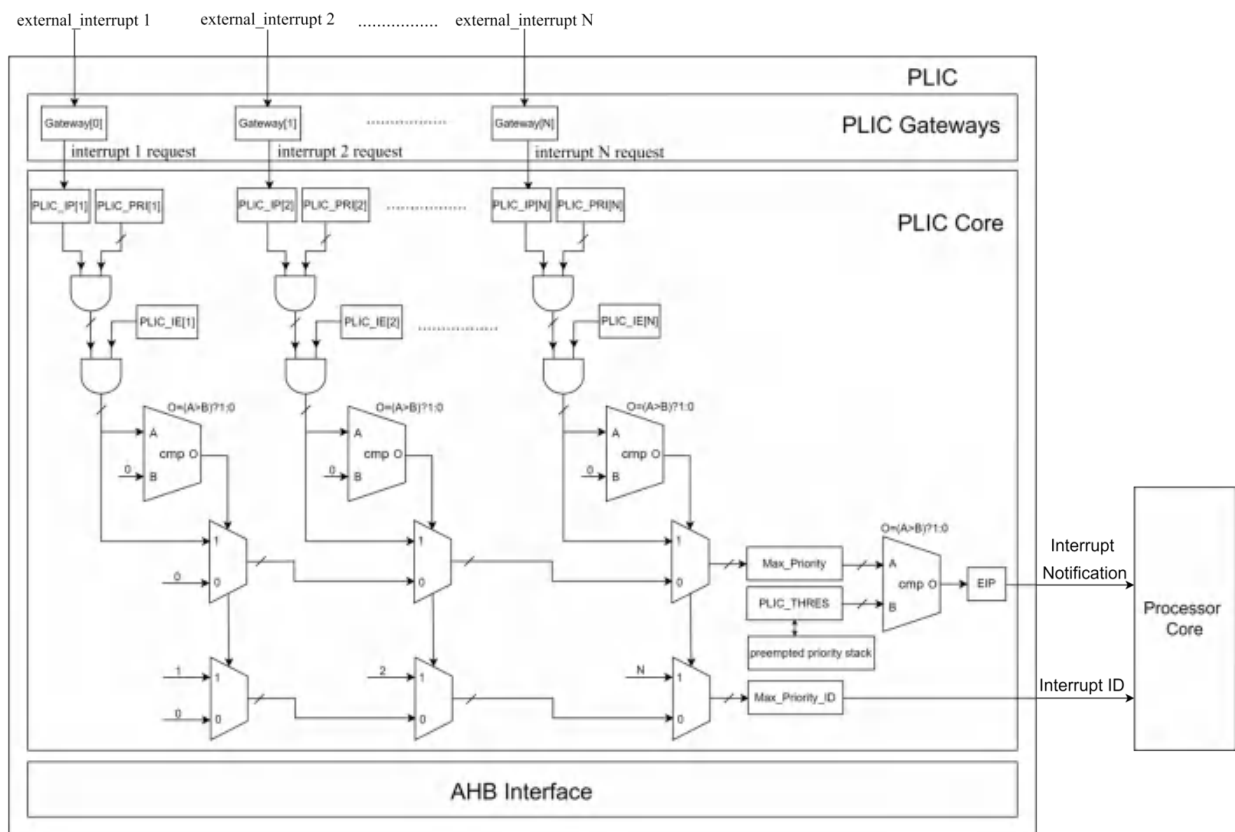

The above figure shows a more detailed block diagram. The PLIC contains multiple interrupt gateways, one per interrupt source, together with a PLIC core that performs interrupt prioritization and routing. External

interrupts are sent from their source to an interrupt gateway that processes the interrupt signal from each source and sends a single interrupt request to the PLIC core, which latches these in the core interrupt pending bits (PLIC_IP). Each interrupt source is assigned a separate priority (PLIC_PRI) and interrupt enable (PLIC_IE). The PLIC core will generate an interrupt notification to the processor core if there are any pending interrupts enabled, and the priority of the pending interrupts exceeds the target threshold (PLIC_THRES). When the target takes the external interrupt, it sends an interrupt claim request to retrieve the identifier of the highest-priority global interrupt source pending for that target from the PLIC core, which then clears the corresponding interrupt source pending bit. After the target has serviced the interrupt, it sends the associated interrupt gateway an interrupt completion message and the interrupt gateway can now forward another interrupt request for the same source to the PLIC.

9.2.2 External Interrupt Sources

There are 46 external interrupt sources, listed in table below.

Table 9-15 Interrupt Sources

No.	Interrupt Source	No.	Interrupt Source
1	stimer_irq: system timer interrupt	24	usb_pwrn_irq: USB suspend interrupt
2	algm_irq: analog register master interface interrupt	25	gpio_irq
3	timer1_irq	26	gpio2risc[0]_irq
4	timer0_irq	27	gpio2risc[1]_irq
5	dma_irq	28	soft_irq: software interrupt
6	bmc_irq: ahb bus matrix controller interrupt	29	mspi_irq
7	usb_setup_irq: USB setup interrupt	30	usb_reset_irq: USB reset interrupt
8	usb_data_irq: USB data interrupt	31	usb_250us_sof_irq: USB 250us or SOF interrupt
9	usb_status_irq: USB status interrupt	32	reserved
10	usb_setinf_irq: USB set interface interrupt	33	qdec_irq
11	usb_edp_irq: USB edp(1-8) interrupt	34	gpio_src_irq[0]: gpio_group_irq[0]
12	reserved	35	gpio_src_irq[1]: gpio_group_irq[1]
13	reserved	36	gpio_src_irq[2]: gpio_group_irq[2]
14	zb_bt_irq:BR/EDR sub-system interrupt	37	gpio_src_irq[3]: gpio_group_irq[3]
15	zb_ble_tl_irq:BLE(TL) sub-system interrupt	38	gpio_src_irq[4]: gpio_group_irq[4]
16	pwm_irq	39	gpio_src_irq[5]: gpio_group_irq[5]
17	pke_irq	40	gpio_src_irq[6]: gpio_group_irq[6]
18	uart1_irq	41	gpio_src_irq[7]: gpio_group_irq[7]

No.	Interrupt Source	No.	Interrupt Source
19	uart0_irq	42	reserved
20	dfifo_irq: audio dma fifo interrupt	43	reserved
21	i2c_irq	44	pm_wkup_irq: PM wakeup interrupt
22	lspi_irq	45	pm_mix_irq: PM mixed interrupt
23	gspi_irq	46	dpr_irq

9.2.3 Support for Preemptive Priority Interrupt

The PLIC implements the preemptive priority interrupt extension which enables faster responses for high-priority interrupts. This feature is enabled by setting `PLIC_FEN.PREEMPT` to 1.

With this extension, if a high-priority interrupt arrives and the global interrupt is enabled (i.e., `mstatus.MIE` is 1), the processor will stop servicing the current low-priority interrupt and begin servicing this new high-priority interrupt. The handling of the suspended lower-priority interrupts will resume only after the handling of the higher-priority interrupt ends. Interrupts of same or lower priorities will not cause preemption to take effect and interfere the handling of the current interrupt. They have to wait until the handling of the current interrupt finishes.

To support this feature, the PLIC core is enhanced with a preempted priority stack. The stack saves and restores priorities of the nested/preempted interrupts.

The operation of the preempted stack is implicitly performed through two regular PLIC operations (Interrupt Claim and Interrupt Completion). See the next two subsections for more information.

9.2.3.1 Interrupt Claims with Preemptive Priority

When the target sends an interrupt claim message to the PLIC core, the PLIC core will atomically determine the ID of the highest-priority pending interrupt for the target and then de-assert the corresponding source's `PLIC_IP` bit. The PLIC core will then return the ID to the target.

At the same time, the priority number in the target's Priority Threshold Register (`PLIC_THRES`) will be saved to a preempted priority stack for that target and the new priority number of the claimed interrupt will be written to `PLIC_THRES`.

9.2.3.2 Interrupt Completion with Preemptive Priority

When the target sends an interrupt completion message to the PLIC core, in addition to forwarding the completion message to the associated gateway, the PLIC core will restore the highest priority number in the preempted priority stack back to `PLIC_THRES`.

Note that out-of-order completion of interrupts is not allowed when this feature is turned on — the latest claimed interrupt should be completed first.

9.2.3.3 Programming Sequence to Allow Preemption of Interrupts

Turning on the global interrupt enable flag (`mstatus.MIE`) is all it takes to allow the current interrupt handler to be preempted by higher priority interrupts. However, as the preemptive priority stack operations do not allow

out-of-order completion, some care should be taken to make sure that the claim and completion operations are nested properly.

For the non-vector mode single-entry interrupt handler, the global interrupt enable flag could be turned on after the processor context are saved and Interrupt Claim is performed to allow preemption of the current interrupt handler. At the end of interrupt handler, an Interrupt Completion message is performed to signal that the handler has processed the interrupt and PLIC may deliver the next interrupt from the same interrupt source again. As both claim and completion messages are done through load/store instructions to device regions, they should automatically be ordered correctly. Compared with the vectored mode interrupt handler two paragraphs below, the global interrupt flag does not need to be disabled and no FENCE needs to be inserted after sending the completion message.

In summary, below is the suggested sequence for a non-vector mode interrupt handler for supporting preemptive priority interrupts:

1. Save registers/CSRs to stack
2. Send Interrupt Claim message to PLIC (device-load)
3. Enable global interrupt (mstatus.MIE)
4. Handle the expected interrupt
5. Send Interrupt Completion message to PLIC (device-store)
6. Restore registers/CSRs
7. Return from interrupt

For vector mode interrupt handlers, Interrupt Claim is implicit when the external interrupt is taken. The global interrupt enable flag could be turned on as long as the processor context are saved to allow preemption of the current interrupt handler. However, the global interrupt flag should be turned off before Interrupt Completion operations are performed, since the processor will trigger the next implicit Interrupt Claim operation as soon as the global interrupt enable flag is turned on and cause races between Interrupt Claim and Interrupt Completion. Additionally, a FENCE io,io operation should be inserted after the Interrupt Completion operation to make sure that the completion message reaches PLIC before the interrupt handler returns, which turns on the interrupt enable flag again and cause the next Interrupt Claim to be performed.

In summary, below is the suggested sequence for a vector mode interrupt handler for supporting preemptive priority interrupts:

1. Save registers/CSRs to stack
2. Enable global interrupt (mstatus.MIE)
3. Handle the expected interrupt
4. Disable global interrupt (mstatus.MIE)
5. Send Interrupt Completion message to PLIC (device-store)
6. Restore registers/CSRs
7. Use a FENCE io, io instruction to ensure that the completion message has reached PLIC.
8. Return from interrupt

9.2.4 Vectored Interrupts

The PLIC enhances the RISC-V PLIC functionality with the vector mode extension to allow the interrupt target to receive the interrupt source ID without going through the target claim request protocol. This feature can shorten the latency of interrupt handling by enabling the interrupt target to run the corresponding interrupt handler directly upon accepting the external interrupt. It is enabled by setting `PLIC_FEN.VECTORED` to 1.

9.2.5 Support for Software-Generated Interrupt

The PLIC also adds support for a software-generated interrupt feature. The interrupt pending registers (`PLIC_IP`) are writable and has the operation definition of “write-1-to-set”, so software can set the pending bit of an interrupt source by writing a 1 to the corresponding bit of the interrupt pending register of the interrupt source.

9.2.6 Interrupt Flow

The below figure shows the messages flowing between agents when handling interrupts via the PLIC.

Figure 9-4 Interrupt Flow

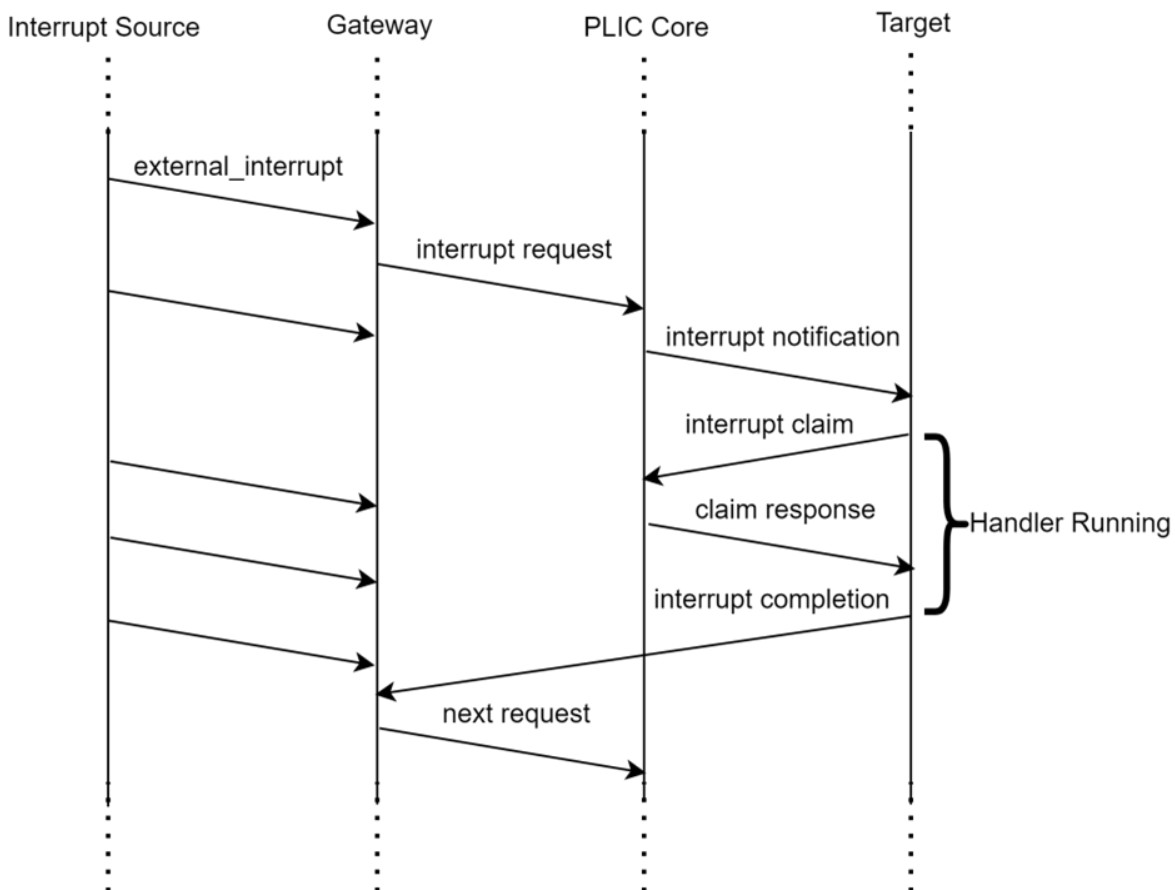

The gateway will only forward a single interrupt request at a time to the PLIC, and not forward subsequent interrupts requests until an interrupt completion is received. The PLIC will set the `PLIC_IP` bit once it accepts an interrupt request from the gateway, and sometime later forward an interrupt notification to the target. The target might take a while to respond to a new interrupt arriving, but will then send an interrupt claim request to the PLIC core to obtain the interrupt ID. The PLIC core will atomically return the ID and clear the

corresponding PLIC_IP bit. Once the handler has processed the interrupt, it sends an interrupt completion message to the gateway to allow a new interrupt request.

9.2.7 Register Description

PLIC related register are listed in table below. The base address for the following registers is 0xE4000000.

Please note that PLIC supports only 32-bit. Behaviors of 8-bit and 16-bit transfers are UNDEFINED, and these transfers might be ignored as well as result in error responses or unexpected register updates.

Table 9-16 Register Configuration for PLIC

Offset	Name	Type	Description	Reset Value
0x00	PLIC_FEN	R/W	Feature Enable Register [0]: PREEMPT, Preemptive priority interrupt enable [1]: VECTORED, Vector mode enable Please note that both this bit and the mmisc_ctl.VEC_PLIC bit of the processor should be turned on for the vectored interrupt support to work correctly.	0x00
0x04*n	PLIC_PRI	R/W	Interrupt Source Priority. This register determines the priority for interrupt source n. [1:0]: Interrupt source priority. 0: Never interrupt, 1-3: Interrupt source priority. The larger the value, the higher the priority.	0x01
0x1000	PLIC_IP	R/W	Interrupt sources 1-31 Pending. The registers provide the interrupt pending status of interrupt sources 1-31, and a way for software to trigger an interrupt without relying on external devices. Every interrupt source occupies 1 bit. When these registers are read, the interrupt pending status of interrupt sources are returned. The pending bits could be set by writing a bit mask that specifies the bit positions to be set, and this action would result in software-programmed interrupts of the corresponding interrupt sources. The pending bits could only be cleared through the Interrupt Claim requests. [31:1]: interrupt pending status of interrupt sources 1-31.	0x00

Offset	Name	Type	Description	Reset Value
0x1004	PLIC_IP_H	R/W	<p>Interrupt sources 32~46 Pending.</p> <p>The registers provide the interrupt pending status of interrupt sources 32~46, and a way for software to trigger an interrupt without relying on external devices. Every interrupt source occupies 1 bit. When these registers are read, the interrupt pending status of interrupt sources are returned. The pending bits could be set by writing a bit mask that specifies the bit positions to be set, and this action would result in software-programmed interrupts of the corresponding interrupt sources. The pending bits could only be cleared through the Interrupt Claim requests.</p> <p>[14:0]: interrupt pending status of interrupt sources 32~46.</p>	0x00
0x2000	PLIC_IE	R/W	<p>Interrupt Enable Bits for interrupt sources 1~31</p> <p>Every interrupt source occupies 1 bit.</p> <p>[31:1]: Interrupt Enable Bits for interrupt sources 1~31</p>	0x00
0x2004	PLIC_IE_H	R/W	<p>Interrupt Enable Bits for interrupt sources 32~46</p> <p>Every interrupt source occupies 1 bit.</p> <p>[14:0]: Interrupt Enable Bits for interrupt sources 32~46.</p>	0x00
0x20000 0	PLIC_THRES	R/W	<p>Priority Threshold</p> <p>[31:0]: THRESHOLD, Interrupt priority threshold</p>	0x0
0x20000 4	PLIC_CLAIM_COMP	R/W	<p>Claim and Complete Register</p> <p>[9:0]: INTERRUPT_ID, On reads, indicating the interrupt source that has being claimed. On writes, indicating the interrupt source that has been handled (completed).</p>	0x0
0x20040 0	PLIC_PPSTACK	R/W	<p>Preempted Priority Stack Register</p> <p>The register is read/writable registers for accessing the preempted priority stack. The purpose of the register is for saving and restoring priorities of the nested/preempted interrupts.</p> <p>[3:0]: Each bit indicates if the corresponding priority level has been preempted by a higher-priority interrupt.</p>	0x00

9.3 Software Platform-Level Interrupt Controller (PLIC_SW)

9.3.1 Introduction

The SoC embeds another one PLIC named PLIC_SW for Software-programmable interrupt generation. It is compatible with RISC-V PLIC with the following features:

- Number of interrupt: 1
- Software-programmable interrupt generation

The below Figure shows the block diagram of PLIC_SW. PLIC_SW doesn't support handling external interrupts, only support Software-programmable interrupt.

For detailed functional descriptions, please refer to PLIC.

Figure 9-5 Block Diagram of PLIC_SW

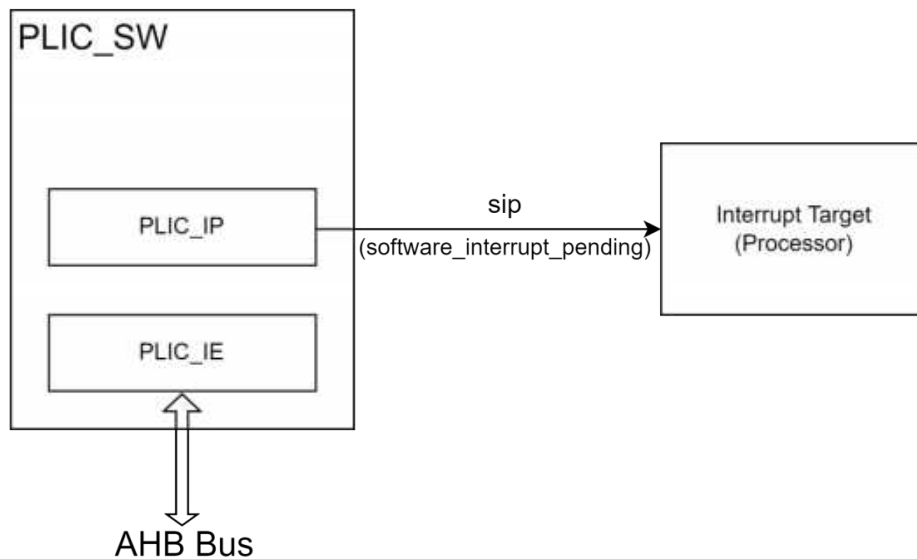

9.3.2 Register Description

The PLIC_SW related register are listed in table below. The base address for the following registers is 0xE6400000.

Please note that PLIC_SW supports only 32-bit. Behaviors of 8-bit and 16-bit transfers are UNDEFINED, and these transfers might be ignored as well as result in error responses or unexpected register updates.

Table 9-17 Register Configuration for PLIC_SW

Offset	Name	Type	Description	Reset Value
0x1000	PLIC_IP	R/W	<p>Interrupt sources 1 Pending.</p> <p>The registers provide the interrupt pending status of interrupt sources 1, and a way for software to trigger an interrupt without relying on external devices. Every interrupt source occupies 1 bit. When these registers are read, the interrupt pending status of interrupt sources are returned. The pending bits could be set by writing a bit mask that specifies the bit positions to be set, and this action would result in software-programmed interrupts of the corresponding interrupt sources. The pending bits could only be cleared through the Interrupt Claim requests.</p> <p>[1]: interrupt pending status of interrupt sources 1.</p>	0x00
0x2000	PLIC_IE	R/W	<p>Interrupt Enable Bits for interrupt sources 1.</p> <p>Every interrupt source occupies 1 bit.</p> <p>[1]: Interrupt Enable Bits for interrupt sources 1</p>	0x00
0x20000 4	PLIC_CLAIM_COMP	R/W	<p>Claim and Complete Register</p> <p>[9:0]: INTERRUPT_ID, On reads, indicating the interrupt source that has being claimed. On writes, indicating the interrupt source that has been handled (completed).</p>	0x00

10 DMA

10.1 Introduction

The SoC embeds DMA (Direct Memory Access) module with DMAC. DMAC is a direct memory access controller which transfers regions of data efficiently on bus.

DMAC features include:

- Supports up to 8 DMA channels
- Supports up to 22 request/acknowledge pairs for hardware handshaking
- Supports chain transfer

10.1.1 Function Description

DMAC supports up to 8 DMA channels. Each DMA channel provides a set of registers to describe the intended data transfers. Multiple DMA channels can be enabled concurrently, but the DMA controller services one channel at a time.

Figure 10-1 shows an illustration of data transfer timing for a channel. In this figure, R means Read, W means Write, n is related with BurstSize, for example, when BurstSize is set to 2, it means 4 DMA transfers are required, n is 3 and details refer to the SrcBurstSize register description in Table 10-5. The details of channel arbitration refers to the next section. To prevent channels from being starved, the DMA controller services all ready-channels alternatively, performing at most SrcBurstSize data transfers each time. Consequently, the data transfers of a channel may be split into several chunks when the total transfer size (TranSize) is larger than the source burst size (SrcBurstSize). When the overall data transfers of a channel complete, the DMA controller will update the interrupt status register, IntStatus, and assert the interrupt signal if the terminal count interrupt is enabled.

The peripherals that support DMA burst transfer include: Audio, MSPI, LSPI and GSPI. For specific supported BurstSize and direction, please refer to the relevant sections of the corresponding peripheral interfaces.

The data transfers of a channel will be stopped when an error occurs. The data transfers of a channel can also be aborted by software. In either case, the DMA controller will disable the channel, and assert the interrupt signal if the corresponding interrupt is enabled.

Figure 10-1 Example of DMA Data Transfers

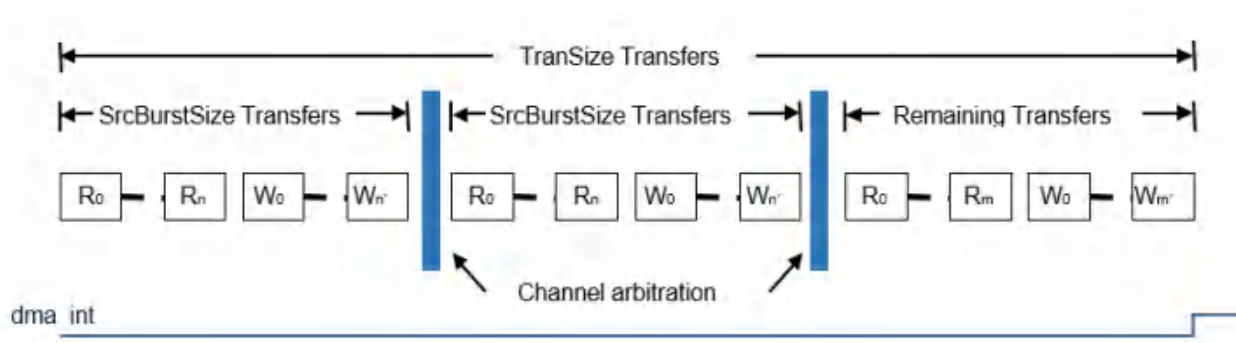

10.1.1.1 Channel Arbitration

DMA provides two priority levels for channel arbitration. Every channel is associated with a priority level by the Priority field of the channel control register, *ChnCtrl*. During the channel arbitration, the DMA controller selects a high priority channel first. A low priority channel is only selected if there is no high priority channel. Channels of the same priority level will be selected by the round-robin scheme.

10.1.1.2 Chain Transfer

DMA provides the chain transfer function, with which multiple blocks of data can be transferred consecutively without the intervention of the main processor.

Before a chain transfer is started, a linked list structure must be built to describe the data blocks to move and the associated control setups. The first element of the list (the head of the list) is described by the channel control registers. The rest of elements of the list are specified by the linked list descriptors stored in the memory, where the linked list descriptor holds the control values to load to the channel control registers to continue the data transfer. Figure 2 shows an example of the linked list structure.

When the channel is enabled, the DMA controller will first transfer data according to the channel control registers. After the data transfer completes, the DMA controller will continue the data transfer by following the *ChnLLPointer*. The content of the linked list descriptor pointed by *ChnLLPointer* will be loaded to the channel control registers if *ChnLLPointer* is not zero. The loaded descriptor becomes the new head of the list and this process repeats until the *ChnLLPointer* is zero.

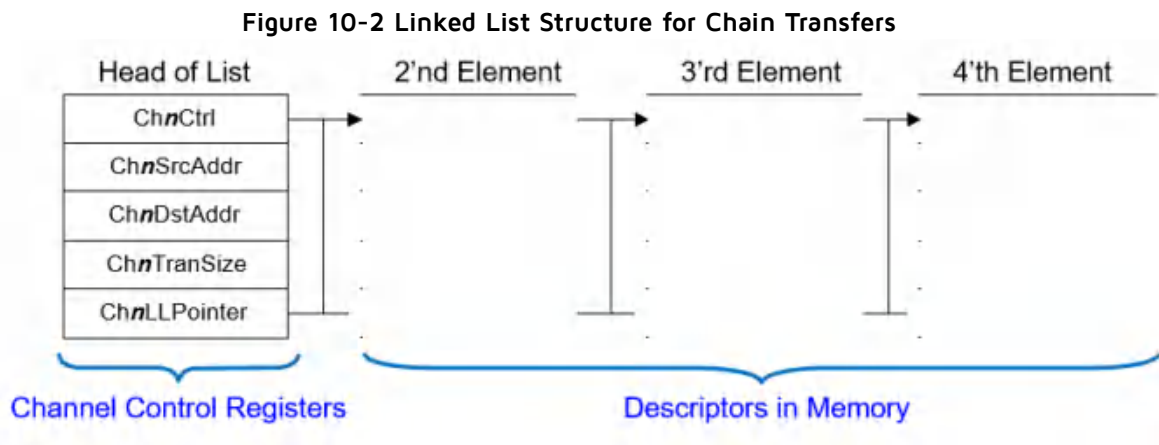

There are three modes of interrupt generation for the linked list, see the description of register *Chn_llp_int_mode* below for details.

(1) When *Chn_llp_int_mode*==0, the linked list interrupt is generated under the following conditions

When the terminal count interrupt (*IntTCMask*) of a channel is enabled, the DMA controller will generate an interrupt and disable the channel when the data transfer for the head of the list is done. If the *ChnLLPointer* is not zero, the channel control registers will be preloaded with the next descriptor before the interrupt is generated. The interrupt handling software could resume the chain transfer by just re-enabling the channel.

(2) When *Chn_llp_int_mode*==1, the linked list interrupt is generated under the following conditions

When the terminal count interrupt (*IntTCMask*) of a channel is enabled, the DMA controller will generate an interrupt and disable the channel when the data transfer for the head of the list is done. If the *ChnLLPointer* is not zero, the interrupt will be generated after each channel control register is completed.

(3) When *Chn_llp_int_mode*==2, the linked list interrupt is generated under the following conditions

When the terminal count interrupt (IntTCMask) of a channel is enabled, the DMA controller will generate an interrupt and disable the channel when the data transfer for the head of the list is done. If the ChnLLPointer is not zero, the interrupt will be generated after each channel control register is completed, and the linked list will be aborted, the software should resume the chain transfer by re-enabling the channel.

The following table shows the format of the linked list descriptor. The bit field definition of each descriptor word is the same as the corresponding channel control register except the channel enable bit, which is reserved in the linked list descriptor.

Table 10-1 Format of Linked List Descriptor

Name	Offset	Description	Format
Ctrl	0x00	Channel control	See Table 10-5
SrcAddr	0x04	Source address	See Table 10-7
DstAddr	0x08	Destination address	See Table 10-8
TranSize	0x0C	Total transfer size	See Table 10-9
LLPointer	0x10	Linked list pointer	See Table 10-10

The peripherals supporting chain transfer include: RX of UART, and audio.

10.1.1.3 Data Order

DMA provides three address control modes: increment mode, decrement mode, and fixed mode. At the increment mode, the address is increased after the DMA controller accesses a data of the source/destination. At the decrement mode, the address is decreased after the DMA controller accesses a data of the source/destination. At the fixed mode, the address remains unchanged after the DMA controller accesses a data of the source/destination.

10.2 Registers

10.2.1 Register Summary

The table below shows a summary of the DMA registers. The base address of DMA is 0x80100400.

Table 10-2 DMA Register Summary

Offset	Name	Description	Category
+0x30	IntStatus	Interrupt status register	Channel status register
+0x38~0x3c	-	Reserved	

Offset	Name	Description	Category
+0x40	ChAbort	Channel abort register	Channel control registers
+0x44 + n*0x14	ChnCtrl	Channel <i>n</i> control register	
+0x48 + n*0x14	ChnSrcAddr	Channel <i>n</i> source address register	
+0x4c + n*0x14	ChnDstAddr	Channel <i>n</i> destination address register	
+0x50 + n*0x14	ChnTranSize	Channel <i>n</i> transfer size register	
+0x54 + n*0x14	ChnLLPointer	Channel <i>n</i> linked list pointer register	

10.2.2 Interrupt Status Register (Offset 0x30)

This register contains the terminal count, error, and abort status. The terminal count status of a channel is asserted when the channel encounters the terminal counter event. The error/abort status of a channel is asserted when the channel encounters the error/abort event. There is one bit of status for each channel and the status bit is zero when the corresponding channel is not configured.

Table 10-3 Interrupt Status Register

Name	Bit	Type	Description	Reset
Reserved	31:24	-	Reserved	-
TC	23:16	R/W1C	The terminal count status of DMA channels, one bit per channel. The terminal count status is asserted when a channel transfer finishes without abort or error event. 0x0: channel N has no terminal count status 0x1: channel N has terminal count status	0x0
Abort	15:8	R/W1C	The abort status of channel, one bit per channel. The abort status is asserted when a channel transfer is aborted. Configure the channel abort register (offset 0x40) corresponding bit to 1 to indicate abort the corresponding DMA channel. 0x0: channel N has no abort status 0x1: channel N has abort status	0x0

Name	Bit	Type	Description	Reset
Error	7:0	R/W1C	<p>The error status, one bit per channel.</p> <p>The error status is asserted when a channel transfer encounters the following error events:</p> <ul style="list-style-type: none"> • Bus error • Unaligned address • Unaligned transfer width • Reserved configuration <p>0x0: channel N has no error status</p> <p>0x1: channel N has error status</p>	0x0

10.2.3 Channel Abort Register (Offset 0x40)

The register controls the abortion of the DMA channel transfers, one-bit per channel. Write 1 to stop the current transfer of the corresponding channel. The abort bit is automatically cleared by hardware when the corresponding status bit in the interrupt status register is cleared.

Table 10-4 Channel Abort Register

Name	Bit	Type	Description	Reset
ChAbort	7:0	WO	<p>Write 1 to this field to stop the channel transfer.</p> <p>The bits can only be set when the corresponding channels are enabled. Otherwise, the writes will be ignored for channels that are not enabled.</p>	0x0

10.2.4 Channel n Control Register (Offset 0x44+n*0x14)

Table 10-5 Channel n Control Register

Name	Bit	Type	Description	Reset
Auto enable en	31	R/W	BB TX RX AUTO EN	0x0
Write_num_en	30	R/W	<p>Enable write num</p> <p>If this register is enabled, the peripheral to SRAM will write the number of bytes received to the first 4 bytes of the destination address at the end of the process. It should be noted that when write_num_en is enabled, CHnTranSize should be set to 0xfffff.</p>	0x0
Priority	29	R/W	<p>Channel priority level</p> <p>0x0: lower priority</p> <p>0x1: reserved</p>	0x0

Name	Bit	Type	Description	Reset
Read_num_en	28	R/W	1:tx_size from ram 0:tx_size from reg If the register is enabled, when TX enables the first data transfer, it will write the first word of the source address to the CHnTranSize register and clear rnum_en. If rnum_en is not enabled, it is needed to configure the CHnTranSize register.	0x0
SrcBurstSize	26:24	R/W	Source burst size. This field indicates the number of transfers before DMA channel re-arbitration. This is configured according to the DMA BusrtSize that can be supported by the peripheral. Total byte of a burst is SrcBurstSize * SrcWidth. 0x0: 1 transfer 0x1: 2 transfers 0x2: 4 transfers 0x3: 8 transfers 0x4: 16 transfers 0x5: 32 transfers 0x6: 64 transfers 0x7: 128 transfers	0x0
SrcWidth	23:22	R/W	Source transfer width 0x0: byte transfer 0x1: half-word transfer 0x2: word transfer 0x3: reserved, setting the field with this value triggers error exception	0x2

Name	Bit	Type	Description	Reset
DstWidth	21:20	R/W	Destination transfer width. Both the total transfer byte and the total burst bytes should be aligned to the destination transfer width; otherwise the error event will be triggered. For example, destination transfer width should be set as byte transfer if total transfer byte is not aligned to word or half-word. See SrcBurstSize field above for the definition of total burst byte for the definition of the total transfer bytes. 0x0: byte transfer 0x1: half-word transfer 0x2: word transfer 0x3: reserved, set the field as this value triggers error exception	0x2
SrcMode	19	R/W	Source DMA handshake mode 0x0: normal mode 0x1: handshake mode	0x0
DstMode	18	R/W	Destination DMA handshake mode 0x0: normal mode 0x1: handshake mode	0x0
SrcAddrCtrl	17:16	R/W	Source address control 0x0: increment address 0x1: decrement address 0x2: fixed address 0x3: reserved, setting the field with this value triggers the error exception	0x0
DstAddrCtrl	15:14	R/W	Destination address control 0x0: increment address 0x1: decrement address 0x2: fixed address 0x3: reserved, setting the field with this value triggers the error exception	0x0
SrcReqSel	13:9	R/W	Source DMA request select. Select the request/ack handshake pair that the source. See Table 10-6 .	0x0

Name	Bit	Type	Description	Reset
DstReqSel	8:4	R/W	Destination DMA request select. Select the request/ack handshake pair that the destination. See Table 10-6 .	0x0
IntAbtMask	3	R/W	Channel abort interrupt mask 0x0: allow the abort interrupt to be triggered 0x1: disable the abort interrupt	0x0
IntErrMask	2	R/W	Channel error interrupt mask 0x0: allow the error interrupt to be triggered 0x1: disable the error interrupt	0x0
IntTCMask	1	R/W	Channel terminal count interrupt mask. 0x0: allow the terminal count interrupt to be triggered 0x1: disable the terminal count interrupt	0x0
Enable	0	R/W	Channel enable bit 0x0: disable 0x1: enable	0x0

The following table shows the labels of the request/ack handshake pair for hardware connections. The SrcReqSel and DstReqSel registers select appropriate number from this table according to the actual functional needs.

Table 10-6 Request/Ack Handshake Pair for Hardware Connection

Signal Name	Request/Ack Selection
lspl_tx	0
lspl_rx	1
uart0_tx	2
uart0_rx	3
gspl_tx	4
gspl_rx	5
i2c_tx	6
i2c_rx	7
zb_tx	8
zb_rx	9
pwm_tx	10

Signal Name	Request/Ack Selection
RSVD	11
algm_tx	12
algm_rx	13
uart1_tx	14
uart1_rx	15
audio0_tx	16
audio0_rx	17
audio1_tx	18
audio1_rx	19
mspi_tx	20
mspi_rx	21

10.2.5 Channel n Source Address Register (Offset 0x48+n*0x14)

Table 10-7 Channel n Source Address Register

Name	Bit	Type	Description	Reset
SrcAddr	31:0	R/W	Source starting address. When a transfer completes, its value is updated to the ending address + sizeof(SrcWidth). This address must be aligned to the source transfer size; otherwise, an error event will be triggered.	0x0

10.2.6 Channel n Destination Address Register (Offset 0x4C+n*0x14)

Table 10-8 Channel n Destination Address Register

Name	Bit	Type	Description	Reset
DstAddr	31:0	R/W	Destination starting address. When a transfer completes, its value is updated to the ending address + sizeof(DstWidth). This address must be aligned to the destination transfer size; otherwise the error event will be triggered.	0x0

Since the data width of the peripherals for DMA transfer are word, it is unified that the DMA SrcAddr and DstAddr are word-aligned.

10.2.7 Channel n Transfer Size Register (Offset 0x50+n*0x14)

Table 10-9 Channel n Transfer Size Register

Name	Bit	Type	Description	Reset
Reserved	31:24	-	-	-
TranSize_idx	23:22	R/W	Byte size	0x0
TranSize	21:0	R/W	Total transfer size from source. The total number of transferred bytes is TranSize * SrcWidth. The value is updated to zero when the DMA transfer is done. If a channel is enabled with zero total transfer size, the error event will be triggered and the transfer will be terminated.	0x0

The actual amount of data transferred is as follows.

For RX, transize_idx is invalid, the actual amount of data transferred = TranSize * SrcWidth.

For TX, transize_idx is valid, when transize_idx is not 0, the actual amount of data transferred = (TranSize - 1) * SrcWidth + TranSize_idx; when transize_idx is 0, the actual amount of data transferred = TranSize * SrcWidth.

When the DMA transfer direction is from peripheral to SRAM, the actual size written to SRAM is TranSize and TranSize_idx is ignored.

10.2.8 Channel n Linked List Pointer Register (Offset 0x54+n*0x14)

Table 10-10 Channel Linked List Pointer Register

Name	Bit	Type	Description	Reset
LLPointer	31:2	R/W	Pointer to the next block descriptor. The pointer must be word aligned.	0x0
Reserved	1:0	-	-	-

10.2.9 Baseband Related Register

Baseband TX can only use channel 0 of DMA, and baseband RX can only use channel 1 of DMA.

For DMA, there are specific functions for the baseband module, the detailed registers are as follows.

Table 10-11 Baseband Related Registers

Name	Address	Bit	Type	Description	Reset
BB_TX_SIZE	0xf0-0xf1	15:0	R/W	Size of each TX buffer, unit is byte.	0x0
BB_TX_CHN_DEP	0xf3	2:0	R/W	Depth of TX FIFO, the actual depth is $2^{BB_TX_CHN_DEP}$	0x0

Name	Address	Bit	Type	Description	Reset
BB_RX_WPTR	0xf4	4:0	R/W	RX_WPTR pointer	0x0
RX_RPTR_CLR	0xf5	7	W1C	Clear the RX_RPTR pointer	0x0
RX_RPTR_NXT		6	W1C	Add 1 to RX_RPTR pointer	0x0
RX_RPTR_SET		5	W1C	Set RX_RPTR pointer	0x0
BB_RX_RPTR		4:0	R/W	Set the specific value of the RX_RPTR pointer	0x0
BB_RX_SIZE	0xf6~0xf7	15:0	R/W	Size of each RX buffer, unit is byte.	0x0
TX_WPTRn	0x100+n*2, n=[0:5]	15:0	R/W	TX_WPTR pointer corresponding to the baseband channel	0x0
TX_RPTRn_CLR	0x101+n*2(n =[0:5])	7	W1C	Clear the TX_WPTR pointer corresponding to the baseband channel	0x0
TX_RPTRn_NXT		6	W1C	Add 1 to the TX_WPTR pointer corresponding to the baseband channel	0x0
TX_RPTRn_SET		5	W1C	Set the TX_WPTR pointer corresponding to the baseband channel	0x0
TX_RPTRn		4:0	R/W	TX_RPTR pointer corresponding to the baseband channel	0x0

Name	Address	Bit	Type	Description	Reset
Dma_req_d1_en	0x10c	5	R/W	Synchronize the dma_request signal to hclk domain	0x0
Ch1_rx_err_en		4	R/W	DMA TC interrupt does not work if baseband rx_err occurs	0x0
Ch_1_rnum_en_bk		3	R/W	ch_1_rnum_en_bk needs to be used with read_num_en because the read_num_en register is cleared to 0 after each first load of TranSize and the value of ch_1_rnum_en_bk is automatically loaded after the DMA transfer is completed	0x0
Ch_0_rnum_en_bk		2	R/W	ch_0_rnum_en_bk needs to be used with read_num_en because the read_num_en register is cleared to 0 after each first load of TranSize and the value of ch_0_rnum_en_bk is automatically loaded after the DMA transfer is completed	0x1
rx_multi_en		1	R/W	The role of rx_multi_en: it will automatically load the destination address register after each DMA transfer and automatically load 0xffff into the TranSize register	0x0
Tx_multi_en		0	R/W	The role of tx_multi_en: DMA will check the read/write pointer of the current baseband channel after receiving the send request from the baseband, if the FIFO of the current baseband channel is empty, DMA will read data from the default buffer.	0x0
Rx_wptr_mask	0x10d	4:0	R/W	Depth of RX FIFO, the actual depth is $2^{\text{rx_wptr_mask}}$	0x0

10.2.10 Miscellaneous Register

Table 10-12 Linked List Interrupt Mode

Name	Address	Bit	Type	Description	Reset
Chn_Ilp_int_mode	0x113-0 x114	[1+n*2: 0+n*2]	R/W	0: Ilp continue mode, the linked list transfer is continuous, interrupt is generated only when the last chain completes 1: Ilp interrupt mode, the linked list does not stop, the interrupt is generated at the completion of each chain 2: Ilp terminal mode, the linked list stops automatically at the completion of each chain, interrupt is generated at the completion of each chain 3: rsvd	0xff

10.3 Usage Guide

10.3.1 From SRAM to SRAM

It is recommended to disable `wnum_en`, `rnum_en` and `auto_enable_en`. For SRAM, the `transize_idx` (only applicable to peripherals) will be invalid. If byte-unit data needs to be transferred from SRAM to SRAM, the `srcwidth` and `dstwidth` control registers need to be set.

Assuming that 1023 bytes of data need to be transferred from address A to address B, B should be written to the destination address register, A should be written to the source address register, 1023 should be written to the `transize` register, and finally the Channel n Control Register (Offset $0x44+n*0x14$) should be configured as the table below.

Table 10-13 Register Configuration for SRAM to SRAM

Bit	Name	Configuration
31	<code>auto_enable_en</code>	Set to 0.
30	<code>wnum_en</code>	Set to 0.
29	<code>priority</code>	Set to 0.
28	<code>rnum_en</code>	Set to 0.
27	<code>reserved</code>	Reserved bit
24-26	<code>src_burst_size</code>	Set to any value stated in Table 10-5 .
22-23	<code>srcwidth</code>	Set to any value stated in Table 10-5 .

Bit	Name	Configuration
20-21	dstwidth	The dstwidth must be aligned with the DMA TranSize. For example, if the DMA TranSize is not aligned with a half word, it should be configured as a byte. If the DMA TranSize is neither aligned with a byte nor aligned with a word, it should be configured as a half word.
19	src_mode	Set to 0.
18	dst_mode	Set to 0.
16-17	src_addr_ctl	Set to 0.
14-15	dst_addr_ctl	Set to 0.
9-13	src_req_sel	Ignore.
4-8	dst_req_sel	Ignore.
3	abort interrupt enable	Enable Abort Interrupt when write 1 to the corresponding channel ChAbort Register.
2	error interrupt enable	Enable Error Interrupt when an error occurs. The detailed error description refers to Error register (Offset 0x30).
1	tc interrupt enable	Enable TC interrupt when DMA transmission completes.
0	enable	Write 1 to start DMA transmission, write 0 to abort transmission.

10.3.2 From SRAM to Peripherals

From SRAM to peripherals, only transferring with srcwidth and dstwidth of word is supported.

Assuming that 1023 bytes of data need to be transferred from SRAM address A to peripheral address B, B should be written to the destination address register, A should be written to the source address register, $(1023+3)/4$ should be written to the transize register, and $1023\%4$ should be written to the transize_idx register. Finally, the Channel n Control Register (Offset $0x44+n*0x14$) should be configured. as the table below.

Table 10-14 Register Configuration for SRAM to Peripherals

Bit	Name	Configuration
31	auto_enable_en	Set to 0.
30	wnum_en	Set to 0.
29	priority	Set to 0.
28	rnum_en	Set to 0.
27	reserved	Reserved bit

Bit	Name	Configuration
24-26	src_burst_size	Set to the burst size that peripheral supports.
22-23	srcwidth	Set to word.
20-21	dstwidth	Set to word.
19	src_mode	Set to 0.
18	dst_mode	Set to 1.
16-17	src_addr_ctl	Set to 0.
14-15	dst_addr_ctl	Set to 2.
9-13	src_req_sel	Ignore.
4-8	dst_req_sel	Set according to the corresponding Request/Ack Selection number of the peripheral in Table 10-6 .
3	abort interrupt enable	Set to the burst size that peripheral supports.
2	error interrupt enable	Enable Error Interrupt when an error occurs. The detailed error description refers to Error register (Offset 0x30).
1	tc interrupt enable	Enable TC Interrupt when DMA transmission completes.
0	enable	Write 1 to start DMA transmission, write 0 to abort transmission.

10.3.3 From Peripherals to SRAM

From peripherals to SRAM, only transferring with srcwidth and dstwidth of word is supported.

If transferring data from peripheral address A to SRAM address B, B should be written to the destination address register, A should be written to the source address register, 0xffffffff should be written to the trsize register since the amount of bytes being transferred is unknown. Finally, the Channel n Control Register (Offset 0x44+n*0x14) should be configured as the table below.

Table 10-15 Register Configuration for Peripherals to SRAM

Bit	Name	Configuration
31	auto_enable_en	Set to 0.
30	wnum_en	Set to 1 to write the number of data received to a word before the destination address.
29	priority	Set to 0.
28	rnum_en	Set to 0.

Bit	Name	Configuration
27	reserved	reserved bit
24-26	src_burst_size	Set to the burst size that peripheral supports.
22-23	srcwidth	Set to word.
20-21	dstwidth	Set to word.
19	src_mode	Set to 1.
18	dst_mode	Set to 0.
16-17	src_addr_ctl	Set to 2.
14-15	dst_addr_ctl	Set to 0.
9-13	src_req_sel	Set according to the corresponding Request/Ack Selection number of the peripheral in Table 10-6 .
4-8	dst_req_sel	Ignore.
3	abort interrupt enable	Enable Abort Interrupt when write 1 to the corresponding channel ChAbort Register.
2	error interrupt enable	Enable Error Interrupt when an error occurs. The detailed error description refers to Error register (Offset 0x30).
1	tc interrupt enable	Enable TC Interrupt when DMA transmission completes.
0	enable	Write 1 to start DMA transmission, write 0 to abort transmission.

10.3.4 From SRAM to Baseband

The configuration method for transferring data from SRAM to baseband is the same as that from SRAM to peripheral mentioned above. However, for the previous method, after each DMA transfer, it's necessary to reconfigure the transize register, source address register, and enable control register (en). In comparison, there are some enhanced functionalities for baseband. After enabling tx_multi_en, DMA will automatically load the source address register. After enabling rnum_en, DMA will automatically load the transize register (also needing to set ch_0_rnum_en_bk at dma_base+0x10c to 1 since rnum_en will be cleared to 0 after every first loading of transize, and it will automatically load the value of ch_0_rnum_en_bk after completing a DMA transfer). By enabling auto_enable_en, the en in the enable control register will be automatically enabled depending on the requests made by baseband. The mechanism for automatic loading of the source address register works as follows:

TX has a total of 6 channels (0-5), it is needed to set the FIFO depth of each chn tx_chn_dep (where 0 represents one buffer, 1 represents two buffers, and 2 represents four buffers) and set the size of each buffer buf_size(bb_tx_size) bytes.

The channel will be fixed on the baseband side for each transfer. After enabling the tx_multi_en of DMA, DMA receives the send request from baseband and views the read/write pointer of the current channel. If the FIFO

of the current channel is empty, DMA will read data from the default buff. If the current channel's FIFO is not empty, DMA will go to the corresponding rptr of the current channel to read the data. The write pointer of TX is maintained by software while the read pointer is maintained by hardware (incremented every time a tx_commit is received by baseband in multi-mode. In case the baseband does not use multi-mode, the software can neglect maintaining the write pointer, making all txfifo's empty; then, the DMA automatically reads data from the default buffer during transmission). Hence, the multi-mode of DMA can be used even when the baseband is in non-multi mode.

10.3.5 From Baseband to SRAM

The same method used for peripheral to SRAM can also be applied to transfer data from baseband to SRAM. Similar to the previous case, after every DMA transfer, configuring destination address register, transize register, and enable control register's en becomes necessary. However, for the Rx channel of baseband, DMA has enhanced functionality. By enabling rx_multi_en, upon completing every DMA transfer, the DMA automatically loads the destination address register and sets the transize register with 0xffffffff. The auto_enable_en in the control register is activated such that when the baseband initiates an RX request, the en register in the control register is automatically enabled.

The mechanism for DMA to automatically load the destination registers:

Unlike TX which has 6 channels, RX has only one FIFO buffer, therefore only the RX FIFO depth rx_wptr_mask(dma_base+0x10d[4:0]) and the buffer size (bb_rx_size) in bytes need to be set.

Whenever a DMA transfer is initiated, DMA reads data from baseband and writes it to the specified address in the destination address register. After completing the transfer, if the received packet is valid, the baseband generates an rx_commit signal to the DMA, which increments the rx_wptr. The next packet of data will then be written into the buffer pointed to by rx_wptr. If the rxfifo's depth is zero, incoming data will continue to be written to the same location.

11 Interface

11.1 GPIO

The SoC supports up to 48 GPIOs. All digital IOs can be used as general purpose IOs.

11.1.1 Basic Configuration

All GPIOs can be configured with related registers, as described as following.

Table 11-1 GPIO Pad Function Mux

Pad	Default	Register = [63:1]	Register = 0	Register
PA[0]	GPIO	All functions	SWM	0x80140348[5:0]
PA[1]	GPIO	All functions	SWM	0x80140349[5:0]
PA[2]	GPIO	All functions ^a	SWM	0x8014034a[5:0]
PA[3]	GPIO	All functions	SWM	0x8014034b[5:0]
PA[4]	GPIO	All functions	SWM	0x8014034c[5:0]
PA[5]	GPIO	-	DM	0x8014034d[5:0]
PA[6]	GPIO	-	DP	0x8014034e[5:0]
PA[7]	SWS	-	SWS	0x8014034f[5:0]
PB[0]	GPIO	All functions	SWM	0x80140350[5:0]
PB[1]	GPIO	All functions	SWM	0x80140351[5:0]
PB[2]	GPIO	All functions	SWM	0x80140352[5:0]
PB[3]	GPIO	All functions	SWM	0x80140353[5:0]
PB[4]	GPIO	All functions	SWM	0x80140354[5:0]
PB[5]	GPIO	All functions	SWM	0x80140355[5:0]
PB[6]	GPIO	All functions	SWM	0x80140356[5:0]
PB[7]	GPIO	All functions	SWM	0x80140357[5:0]
PC[0]	SSPI_CN	All functions	SSPI_CN	0x80140358[5:0]
PC[1]	SSPI_CK	All functions	SSPI_CK	0x80140359[5:0]
PC[2]	SSPI_SI	All functions	SSPI_SI	0x8014035a[5:0]
PC[3]	SSPI_SO	All functions	SSPI_SO	0x8014035b[5:0]
PC[4]	TDI	All functions	TDI	0x8014035c[5:0]

Pad	Default	Register = [63:1]	Register = 0	Register
PC[5]	TDO	All functions	TDO	0x8014035d[5:0]
PC[6]	TMS	All functions	TMS	0x8014035e[5:0]
PC[7]	TCK	All functions	TCK	0x8014035f[5:0]
PD[0]	GPIO	All functions	SWM	0x80140360[5:0]
PD[1]	GPIO	All functions	SWM	0x80140361[5:0]
PD[2]	GPIO	All functions	SWM	0x80140362[5:0]
PD[3]	GPIO	All functions	SWM	0x80140363[5:0]
PD[4]	GPIO	All functions	SWM	0x80140364[5:0]
PD[5]	GPIO	All functions	SWM	0x80140365[5:0]
PD[6]	GPIO	All functions	SWM	0x80140366[5:0]
PD[7]	GPIO	All functions	SWM	0x80140367[5:0]
PE[0]	GPIO	-	LSPL_CN	0x80140368[5:0]
PE[1]	GPIO	-	LSPL_CK	0x80140369[5:0]
PE[2]	GPIO	-	LSPL_MOSI	0x8014036a[5:0]
PE[3]	GPIO	-	LSPL_MISO	0x8014036b[5:0]
PE[4]	GPIO	-	LSPL_IO2	0x8014036c[5:0]
PE[5]	GPIO	-	LSPL_IO3	0x8014036d[5:0]
PE[6]	GPIO	All functions	SWM	0x8014036e[5:0]
PE[7]	GPIO	All functions	SWM	0x8014036f[5:0]
PF[0]	GPIO	All functions	SWM	0x80140370[5:0]
PF[1]	GPIO	All functions	SWM	0x80140371[5:0]
PF[2]	GPIO	All functions	SWM	0x80140372[5:0]
PF[3]	GPIO	All functions	SWM	0x80140373[5:0]
PF[4]	GPIO	All functions	SWM	0x80140374[5:0]
PF[5]	GPIO	All functions	SWM	0x80140375[5:0]
PF[6]	GPIO	All functions special ^b	SWM	0x80140376[5:0]
PF[7]	GPIO	All functions special	SWM	0x80140377[5:0]

- a. "All functions" include 60 functions: GSPI_CN3, GSPI_CN2, GSPI_CN1, I2C1_SCL, I2C1_SDA, RX_CYC2LNA, ATSEL_3, ATSEL_2, ATSEL_1, ATSEL_0, BT_INBAND, BT_STATUS, BT_ACTIVITY, WIFI_DENY, TX_CYC2PA, DMIC1_DAT, DMIC1_CLK, DMICO_DAT, DMICO_CLK, I2S1_CLK, I2S1_DAT_IN, I2S1_LR_IN, I2S1_DAT_OUT, I2S1_LR_OUT, I2S1_BCK, I2SO_CLK, I2SO_DAT_IN, I2SO_LR_IN, I2SO_DAT_OUT, I2SO_LR_OUT, I2SO_BCK, CLK_7816, UART1_RTX, UART1_TX, UART1_RTS, UART1_CTS, UART0_RTX, UART0_TX, UART0_RTS, UART0_CTS, I2C_SDA, I2C_SCL, GSPI_MOSI, GSPI_MISO, GSPI_IO2, GSPI_IO3, GSPI_CK, GSPI_CNO, PWM5_N, PWM4_N, PWM3_N, PWM2_N, PWM1_N, PWMO_N, PWM5, PWM4, PWM3, PWM2, PWM1, and PWMO.
- b. "All functions special" include 55 functions, which is above 60 functions exclude GSPI_CN3, GSPI_CN2, GSPI_CN1, I2C1_SCL, and I2C1_SDA.

Flash IO multiple functions are listed in table below:

Table 11-2 Flash IO Pin Mux

Pad	Default
PG[0]	MSPI_MOSI
PG[1]	MSPI_CK
PG[2]	MSPI_IO3
PG[3]	MSPI_CN
PG[4]	MSPI_MISO
PG[5]	MSPI_IO2

Table 11-3 GPIO Setting

Pad	Input	IE	OEN	Output	Polarity	DS	Act as GPIO
PA[0]	0x8014030 0 [0]	0x8014030 1 [0]	0x8014030 2 [0]	0x8014030 3 [0]	0x8014030 4 [0]	0x8014030 5 [0]	0x8014030 6 [0]
PA[1]	0x8014030 0 [1]	0x8014030 1 [1]	0x8014030 2 [1]	0x8014030 3 [1]	0x8014030 4 [1]	0x8014030 5 [1]	0x8014030 6 [1]
PA[2]	0x8014030 0 [2]	0x8014030 1 [2]	0x8014030 2 [2]	0x8014030 3 [2]	0x8014030 4 [2]	0x8014030 5 [2]	0x8014030 6 [2]
PA[3]	0x8014030 0 [3]	0x8014030 1 [3]	0x8014030 2 [3]	0x8014030 3 [3]	0x8014030 4 [3]	0x8014030 5 [3]	0x8014030 6 [3]
PA[4]	0x8014030 0 [4]	0x8014030 1 [4]	0x8014030 2 [4]	0x8014030 3 [4]	0x8014030 4 [4]	0x8014030 5 [4]	0x8014030 6 [4]
PA[5]	0x8014030 0 [5]	0x8014030 1 [5]	0x8014030 2 [5]	0x8014030 3 [5]	0x8014030 4 [5]	0x8014030 5 [5]	0x8014030 6 [5]

Pad	Input	IE	OEN	Output	Polarity	DS	Act as GPIO
PA[6]	0x8014030 0 [6]	0x8014030 1 [6]	0x8014030 2 [6]	0x8014030 3 [6]	0x8014030 4 [6]	0x8014030 5 [6]	0x8014030 6 [6]
PA[7]	0x8014030 0 [7]	0x8014030 1 [7]	0x8014030 2 [7]	0x8014030 3 [7]	0x8014030 4 [7]	0x8014030 5 [7]	0x8014030 6 [7]
PB[0]	0x8014030 8 [0]	0x8014030 9 [0]	0x8014030 a [0]	0x8014030 b [0]	0x8014030 c [0]	0x8014030 d [0]	0x8014030 e [0]
PB[1]	0x8014030 8 [1]	0x8014030 9 [1]	0x8014030 a [1]	0x8014030 b [1]	0x8014030 c [1]	0x8014030 d [1]	0x8014030 e [1]
PB[2]	0x8014030 8 [2]	0x8014030 9 [2]	0x8014030 a [2]	0x8014030 b [2]	0x8014030 c [2]	0x8014030 d [2]	0x8014030 e [2]
PB[3]	0x8014030 8 [3]	0x8014030 9 [3]	0x8014030 a [3]	0x8014030 b [3]	0x8014030 c [3]	0x8014030 d [3]	0x8014030 e [3]
PB[4]	0x8014030 8 [4]	0x8014030 9 [4]	0x8014030 a [4]	0x8014030 b [4]	0x8014030 c [4]	0x8014030 d [4]	0x8014030 e [4]
PB[5]	0x8014030 8 [5]	0x8014030 9 [5]	0x8014030 a [5]	0x8014030 b [5]	0x8014030 c [5]	0x8014030 d [5]	0x8014030 e [5]
PB[6]	0x8014030 8 [6]	0x8014030 9 [6]	0x8014030 a [6]	0x8014030 b [6]	0x8014030 c [6]	0x8014030 d [6]	0x8014030 e [6]
PB[7]	0x8014030 8 [7]	0x8014030 9 [7]	0x8014030 a [7]	0x8014030 b [7]	0x8014030 c [7]	0x8014030 d [7]	0x8014030 e [7]
PC[0]	0x8014031 0 [0]	ana_0xbd [0]	0x8014031 2 [0]	0x8014031 3 [0]	0x8014031 4 [0]	ana_0xbf [0]	0x8014031 6 [0]
PC[1]	0x8014031 0 [1]	ana_0xbd [1]	0x8014031 2 [1]	0x8014031 3 [1]	0x8014031 4 [1]	ana_0xbf [1]	0x8014031 6 [1]
PC[2]	0x8014031 0 [2]	ana_0xbd [2]	0x8014031 2 [2]	0x8014031 3 [2]	0x8014031 4 [2]	ana_0xbf [2]	0x8014031 6 [2]
PC[3]	0x8014031 0 [3]	ana_0xbd [3]	0x8014031 2 [3]	0x8014031 3 [3]	0x8014031 4 [3]	ana_0xbf [3]	0x8014031 6 [3]
PC[4]	0x8014031 0 [4]	ana_0xbd [4]	0x8014031 2 [4]	0x8014031 3 [4]	0x8014031 4 [4]	ana_0xbf [4]	0x8014031 6 [4]
PC[5]	0x8014031 0 [5]	ana_0xbd [5]	0x8014031 2 [5]	0x8014031 3 [5]	0x8014031 4 [5]	ana_0xbf [5]	0x8014031 6 [5]

Pad	Input	IE	OEN	Output	Polarity	DS	Act as GPIO
PC[6]	0x8014031 0 [6]	ana_0xbd [6]	0x8014031 2 [6]	0x8014031 3 [6]	0x8014031 4 [6]	ana_0xbf [6]	0x8014031 6 [6]
PC[7]	0x8014031 0 [7]	ana_0xbd [7]	0x8014031 2 [7]	0x8014031 3 [7]	0x8014031 4 [7]	ana_0xbf [7]	0x8014031 6 [7]
PD[0]	0x8014031 8 [0]	ana_0xc0 [0]	0x8014031a [0]	0x8014031 b [0]	0x8014031c [0]	ana_0xc2 [0]	0x8014031 e [0]
PD[1]	0x8014031 8 [1]	ana_0xc0 [1]	0x8014031a [1]	0x8014031 b [1]	0x8014031c [1]	ana_0xc2 [1]	0x8014031 e [1]
PD[2]	0x8014031 8 [2]	ana_0xc0 [2]	0x8014031a [2]	0x8014031 b [2]	0x8014031c [2]	ana_0xc2 [2]	0x8014031 e [2]
PD[3]	0x8014031 8 [3]	ana_0xc0 [3]	0x8014031a [3]	0x8014031 b [3]	0x8014031c [3]	ana_0xc2 [3]	0x8014031 e [3]
PD[4]	0x8014031 8 [4]	ana_0xc0 [4]	0x8014031a [4]	0x8014031 b [4]	0x8014031c [4]	ana_0xc2 [4]	0x8014031 e [4]
PD[5]	0x8014031 8 [5]	ana_0xc0 [5]	0x8014031a [5]	0x8014031 b [5]	0x8014031c [5]	ana_0xc2 [5]	0x8014031 e [5]
PD[6]	0x8014031 8 [6]	ana_0xc0 [6]	0x8014031a [6]	0x8014031 b [6]	0x8014031c [6]	ana_0xc2 [6]	0x8014031 e [6]
PD[7]	0x8014031 8 [7]	ana_0xc0 [7]	0x8014031a [7]	0x8014031 b [7]	0x8014031c [7]	ana_0xc2 [7]	0x8014031 e [7]
PE[0]	0x8014032 0 [0]	0x8014032 1 [0]	0x8014032 2 [0]	0x8014032 3 [0]	0x8014032 4 [0]	0x8014032 5 [0]	0x8014032 6 [0]
PE[1]	0x8014032 0 [1]	0x8014032 1 [1]	0x8014032 2 [1]	0x8014032 3 [1]	0x8014032 4 [1]	0x8014032 5 [1]	0x8014032 6 [1]
PE[2]	0x8014032 0 [2]	0x8014032 1 [2]	0x8014032 2 [2]	0x8014032 3 [2]	0x8014032 4 [2]	0x8014032 5 [2]	0x8014032 6 [2]
PE[3]	0x8014032 0 [3]	0x8014032 1 [3]	0x8014032 2 [3]	0x8014032 3 [3]	0x8014032 4 [3]	0x8014032 5 [3]	0x8014032 6 [3]
PE[4]	0x8014032 0 [4]	0x8014032 1 [4]	0x8014032 2 [4]	0x8014032 3 [4]	0x8014032 4 [4]	0x8014032 5 [4]	0x8014032 6 [4]
PE[5]	0x8014032 0 [5]	0x8014032 1 [5]	0x8014032 2 [5]	0x8014032 3 [5]	0x8014032 4 [5]	0x8014032 5 [5]	0x8014032 6 [5]

Pad	Input	IE	OEN	Output	Polarity	DS	Act as GPIO
PE[6]	0x8014032 0 [6]	0x8014032 1 [6]	0x8014032 2 [6]	0x8014032 3 [6]	0x8014032 4 [6]	0x8014032 5 [6]	0x8014032 6 [6]
PE[7]	0x8014032 0 [7]	0x8014032 1 [7]	0x8014032 2 [7]	0x8014032 3 [7]	0x8014032 4 [7]	0x8014032 5 [7]	0x8014032 6 [7]
PF[0]	0x8014032 8 [0]	0x8014032 9 [0]	0x8014032 a [0]	0x8014032 b [0]	0x8014032 c [0]	0x8014032 d [0]	0x8014032 e [0]
PF[1]	0x8014032 8 [1]	0x8014032 9 [1]	0x8014032 a [1]	0x8014032 b [1]	0x8014032 c [1]	0x8014032 d [1]	0x8014032 e [1]
PF[2]	0x8014032 8 [2]	0x8014032 9 [2]	0x8014032 a [2]	0x8014032 b [2]	0x8014032 c [2]	0x8014032 d [2]	0x8014032 e [2]
PF[3]	0x8014032 8 [3]	0x8014032 9 [3]	0x8014032 a [3]	0x8014032 b [3]	0x8014032 c [3]	0x8014032 d [3]	0x8014032 e [3]
PF[4]	0x8014032 8 [4]	0x8014032 9 [4]	0x8014032 a [4]	0x8014032 b [4]	0x8014032 c [4]	0x8014032 d [4]	0x8014032 e [4]
PF[5]	0x8014032 8 [5]	0x8014032 9 [5]	0x8014032 a [5]	0x8014032 b [5]	0x8014032 c [5]	0x8014032 d [5]	0x8014032 e [5]
PF[6]	0x8014032 8 [6]	0x8014032 9 [6]	0x8014032 a [6]	0x8014032 b [6]	0x8014032 c [6]	0x8014032 d [6]	0x8014032 e [6]
PF[7]	0x8014032 8 [7]	0x8014032 9 [7]	0x8014032 a [7]	0x8014032 b [7]	0x8014032 c [7]	0x8014032 d [7]	0x8014032 e [7]
PG[0]	0x8014033 0 [0]	0x8014033 1 [0]	0x8014033 2 [0]	0x8014033 3 [0]	0x8014033 4 [0]	0x8014033 5 [0]	0x8014033 6 [0]
PG[1]	0x8014033 0 [1]	0x8014033 1 [1]	0x8014033 2 [1]	0x8014033 3 [1]	0x8014033 4 [1]	0x8014033 5 [1]	0x8014033 6 [1]
PG[2]	0x8014033 0 [2]	0x8014033 1 [2]	0x8014033 2 [2]	0x8014033 3 [2]	0x8014033 4 [2]	0x8014033 5 [2]	0x8014033 6 [2]
PG[3]	0x8014033 0 [3]	0x8014033 1 [3]	0x8014033 2 [3]	0x8014033 3 [3]	0x8014033 4 [3]	0x8014033 5 [3]	0x8014033 6 [3]
PG[4]	0x8014033 0 [4]	0x8014033 1 [4]	0x8014033 2 [4]	0x8014033 3 [4]	0x8014033 4 [4]	0x8014033 5 [4]	0x8014033 6 [4]
PG[5]	0x8014033 0 [5]	0x8014033 1 [5]	0x8014033 2 [5]	0x8014033 3 [5]	0x8014033 4 [5]	0x8014033 5 [5]	0x8014033 6 [5]

NOTE:

- IE: Input enable, high active. 1: enable input, 0: disable input.
- OEN: Output enable, low active. 0: enable output, 1: disable output.
- Output: configure GPO output.
- Input: read GPI input.
- DS: Drive strength. 1: maximum DS level (default), 0: minimal DS level.
- Act as GPIO: enable (1) or disable (0) GPIO function.
- Polarity: see section below

Table 11-4 GPIO Function Mux Configuration Registers

Address	Type	Description	Default Value
0x80140348	RW	[5:0]: function control bits of PA0_FS	0x00
0x80140349	RW	[5:0]: function control bits of PA1_FS	0x00
0x8014034a	RW	[5:0]: function control bits of PA2_FS	0x00
0x8014034b	RW	[5:0]: function control bits of PA3_FS	0x00
0x8014034c	RW	[5:0]: function control bits of PA4_FS	0x00
0x8014034d	R	[5:0]: function control bits of PA5_FS	0x00
0x8014034e	R	[5:0]: function control bits of PA6_FS	0x00
0x8014034f	R	[5:0]: function control bits of PA7_FS	0x00
0x80140350	RW	[5:0]: function control bits of PB0_FS	0x00
0x80140351	RW	[5:0]: function control bits of PB1_FS	0x00
0x80140352	RW	[5:0]: function control bits of PB2_FS	0x00
0x80140353	RW	[5:0]: function control bits of PB3_FS	0x00
0x80140354	RW	[5:0]: function control bits of PB4_FS	0x00
0x80140355	RW	[5:0]: function control bits of PB5_FS	0x00
0x80140356	RW	[5:0]: function control bits of PB6_FS	0x00
0x80140357	RW	[5:0]: function control bits of PB7_FS	0x00
0x80140358	RW	[5:0]: function control bits of PC0_FS	0x00
0x80140359	RW	[5:0]: function control bits of PC1_FS	0x00
0x8014035a	RW	[5:0]: function control bits of PC2_FS	0x00
0x8014035b	RW	[5:0]: function control bits of PC3_FS	0x00

Address	Type	Description	Default Value
0x8014035c	RW	[5:0]: function control bits of PC4_FS	0x00
0x8014035d	RW	[5:0]: function control bits of PC5_FS	0x00
0x8014035e	RW	[5:0]: function control bits of PC6_FS	0x00
0x8014035f	RW	[5:0]: function control bits of PC7_FS	0x00
0x80140360	RW	[5:0]: function control bits of PD0_FS	0x00
0x80140361	RW	[5:0]: function control bits of PD1_FS	0x00
0x80140362	RW	[5:0]: function control bits of PD2_FS	0x00
0x80140363	RW	[5:0]: function control bits of PD3_FS	0x00
0x80140364	RW	[5:0]: function control bits of PD4_FS	0x00
0x80140365	RW	[5:0]: function control bits of PD5_FS	0x00
0x80140366	RW	[5:0]: function control bits of PD6_FS	0x00
0x80140367	RW	[5:0]: function control bits of PD7_FS	0x00
0x80140368	R	[5:0]: function control bits of PE0_FS	0x00
0x80140369	R	[5:0]: function control bits of PE1_FS	0x00
0x8014036a	R	[5:0]: function control bits of PE2_FS	0x00
0x8014036b	R	[5:0]: function control bits of PE3_FS	0x00
0x8014036c	R	[5:0]: function control bits of PE4_FS	0x00
0x8014036d	R	[5:0]: function control bits of PE5_FS	0x00
0x8014036e	RW	[5:0]: function control bits of PE6_FS	0x00
0x8014036f	RW	[5:0]: function control bits of PE7_FS	0x00
0x80140370	RW	[5:0]: function control bits of PF0_FS	0x00
0x80140371	RW	[5:0]: function control bits of PF1_FS	0x00
0x80140372	RW	[5:0]: function control bits of PF2_FS	0x00
0x80140373	RW	[5:0]: function control bits of PF3_FS	0x00
0x80140374	RW	[5:0]: function control bits of PF4_FS	0x00
0x80140375	RW	[5:0]: function control bits of PF5_FS	0x00
0x80140376	RW	[5:0]: function control bits of PF6_FS	0x00
0x80140377	RW	[5:0]: function control bits of PF7_FS	0x00

11.1.2 Connection Relationship between GPIO and Related Modules

GPIO can be used to generate GPIO interrupt signal for interrupt system, counting or control signal for Timer/Counter module, or gpio2risc interrupt signal for interrupt system.

For the “Exclusive Or (XOR)” operation result for input signal from any GPIO pin and respective “Polarity” value, on one hand, it takes “And” operation with “irq” and generates GPIO interrupt request signal; on the other hand, it takes “And” operation with “MO/M1”, and generates counting signal in Mode 1 or control signal in Mode 2 for Timer0/Timer1, or generates GPIO2RISC[0]/GPIO2RISC[1] interrupt request signal.

- **gpio_irq**: GPIO interrupt request signal = $| ((\text{Input} \wedge \text{Polarity}) \& \text{IRQ})$, it is the interrupt request signal generated from GPIO;
- **gpio2risc[0]_irq**: GPIO2RISC[0] interrupt request signal = $| ((\text{Input} \wedge \text{Polarity}) \& \text{MO})$, it is the interrupt request signal generated from GPIO and MO registers;
- **timer0_irq**: Counting (Mode 1) or control (Mode 2) signal for Timer0 = $| ((\text{Input} \wedge \text{Polarity}) \& \text{MO})$, it is the interrupt request signal generated from GPIO, MO and Timer0;
- **gpio2risc[1]_irq**: GPIO2RISC[1] interrupt request signal = $| ((\text{Input} \wedge \text{Polarity}) \& \text{M1})$, it is the interrupt request signal generated from GPIO and M1 registers;
- **timer1_irq**: Counting (Mode 1) or control (Mode 2) signal for Timer1 = $| ((\text{input} \wedge \text{polarity}) \& \text{M1})$, it is the interrupt request signal generated from GPIO, MO and Timer1;
- **gpio_group_irq**: gpio_group_irq[7:0] interrupt request signals are from a set of GPIO, which can be configured via registers GPIO_GROUP_IRQ_SEL[2:0].

The logic relationship is shown in figure below.

Figure 11-1 Logic Relationship between GPIO and Related Modules

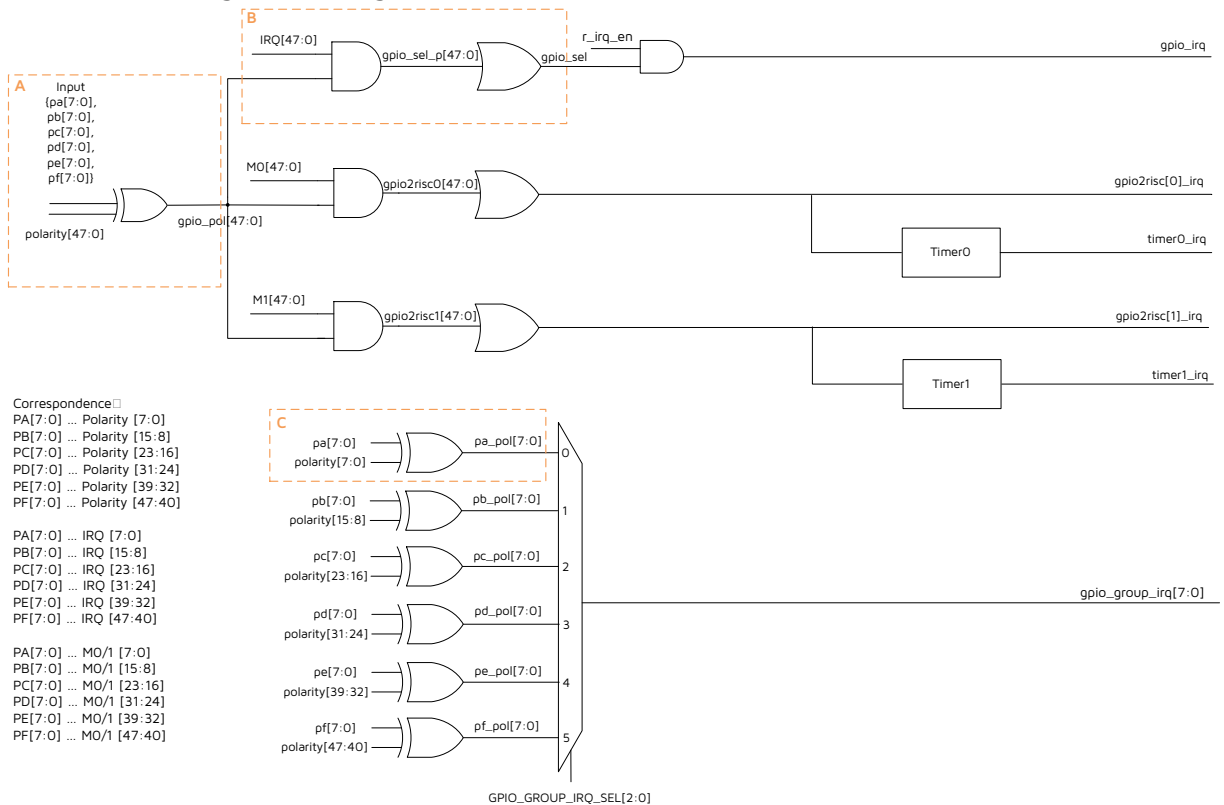

In the figure above, the detailed digital circuit for part A is shown as below. The input register and polarity register of each corresponding GPIO pin take XOR operation to get one gpio_pol signal. The output of this part is gpio_pol[47:0] which is a set of 48 bits signals.

Figure 11-2 Detailed Circuit for Part A

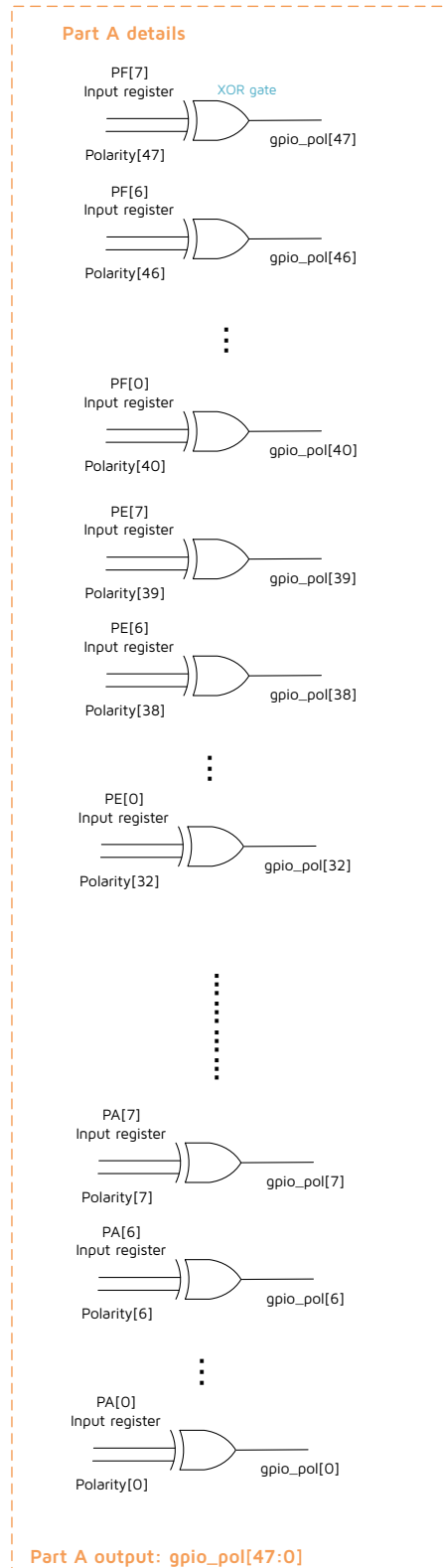

The detailed digital circuit for part B is shown as below. The IRQ register and gpio_pol signal of each corresponding GPIO pin take AND operation to get one gpio_sel_p signal, then 48 bits gpio_sel_p signals take OR operation to get one gpio_sel signal. The output of this part is gpio_sel which is the 1 bit signal.

Figure 11-3 Detailed Circuit for Part B

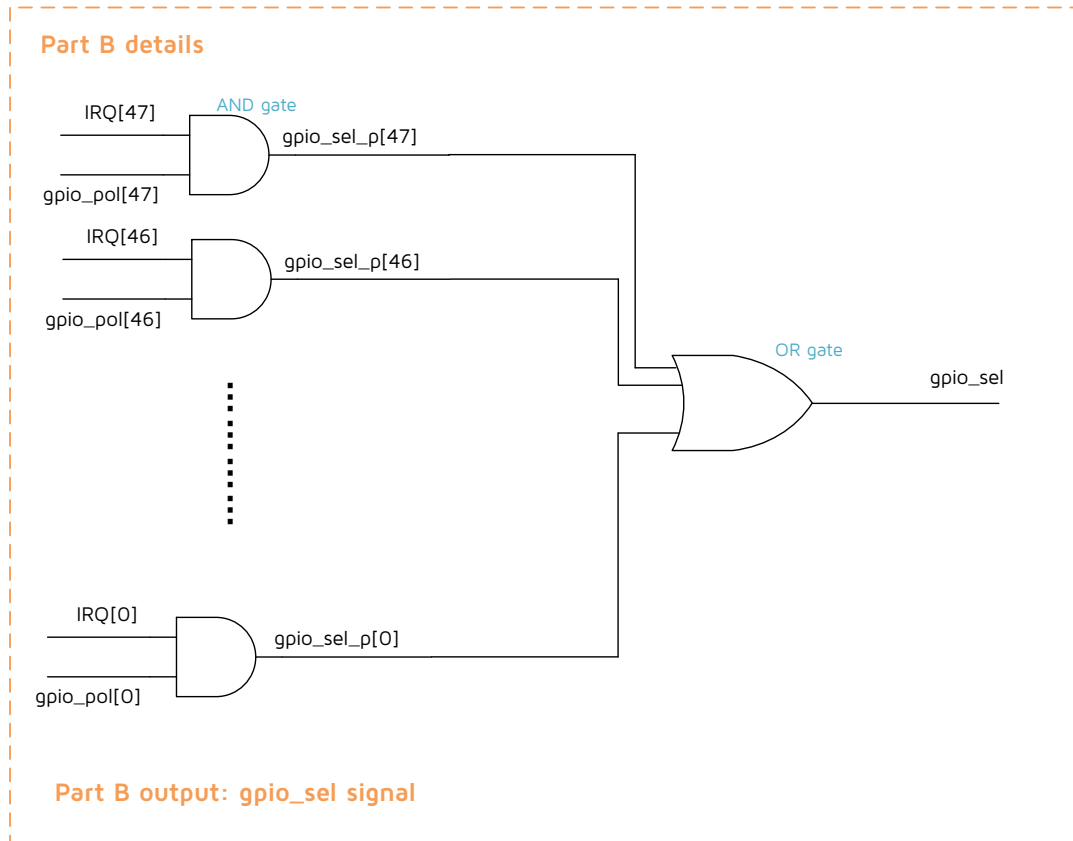

For the detailed digital circuit of M0[47:0] to gpio2risc[0]_irq and M1[47:0] to gpio2risc[1]_irq, the operations are similar with the detailed circuit of part B.

The detailed digital circuit for part C is shown as below. The output of this part is pa_pol[7:0] which is a set of 8 bits signals.

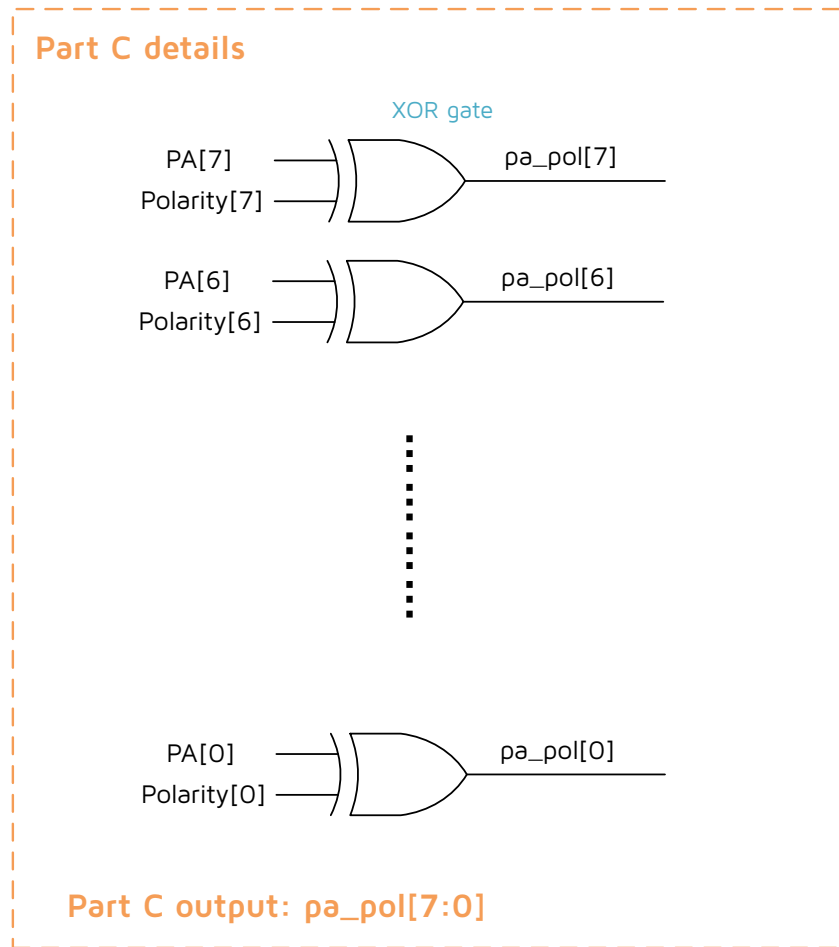
Figure 11-4 Detailed Circuit of Part C

Similarly, the output of the circuits below part C are pb_pol[7:0], pc_pol[7:0], pd_pol[7:0], pe_pol[7:0], and pf_pol[7:0]. The 6 groups of px_pol signals mux with GPIO_GROUP_IRQ_SEL[2:0] to get gpio_irq_group signals.

Please note that gpio_group_irq[7] is the result from pa_pol[7], pb_pol[7], pc_pol[7], pd_pol[7], pe_pol[7], pf_pol[7] and GPIO_GROUP_IRQ_SEL[2:0], and similarly, gpio_group_irq[6] is the result from pa_pol[6], pb_pol[6], pc_pol[6], pd_pol[6], pe_pol[6], pf_pol[6] and GPIO_GROUP_IRQ_SEL[2:0], and so on. This is different from the above interrupt request signals shown in [Figure 11-1 Logic Relationship between GPIO and Related Modules](#), they are the operation results from all 48 GPIOs.

11.1.3 Drive Strength

The registers in the “DS” column are used to configure the corresponding pin’s driving strength: “1” indicates maximum drive level, while “0” indicates minimal drive level.

The “DS” configuration will take effect when the pin is used as output. It’s set as the strongest driving level by default. In actual applications, driving strength can be decreased to lower level if necessary.

- PA[5:7], PE[0:1], PE[4:7], PF[0:7]: maximum = 8 mA (“DS” = 1), minimum = 4 mA (“DS” = 0)
- Other GPIOs (PA[0:4], PB[0:7], PC[0:7], PD[0:7], PE[2:3], and PG[0:5]): maximum = 4 mA (“DS” = 1), minimum = 2 mA (“DS” = 0)

11.1.4 Polarity

By configuring “Polarity” registers, user can determine GPIO edges in Timer modes. In Timer Mode 1, it determines GPIO edge when Timer Tick counting increases. In Timer Mode 2, it determines GPIO edge when Timer Tick starts counting.

Users can read addresses to see which GPIO asserts counting signals (Mode 1) / control signal (Mode 2) for Timers.

11.1.5 GPIO IRQ Signal

Select GPIO interrupt trigger edge (positive edge or negative edge) via configuring “Polarity”, and set corresponding GPIO interrupt enabling bit “Irq”.

11.1.6 GPIO2RISC IRQ Signal

Select GPIO2RISC interrupt trigger edge (positive edge or negative edge) via configuring “Polarity”, and set corresponding GPIO enabling bit “M0”/“M1”, then enable GPIO2RISC[0]/GPIO2RISC[1] interrupt.

Table 11-5 GPIO IRQ Table

Pad	Input	IRQ	M0	M1	Polarity
PA[0]	0x80140300[0]	0x80140307[0]	0x80140338[0]	0x80140340[0]	0x80140304[0]
PA[1]	0x80140300[1]	0x80140307[1]	0x80140338[1]	0x80140340[1]	0x80140304[1]
PA[2]	0x80140300[2]	0x80140307[2]	0x80140338[2]	0x80140340[2]	0x80140304[2]
PA[3]	0x80140300[3]	0x80140307[3]	0x80140338[3]	0x80140340[3]	0x80140304[3]
PA[4]	0x80140300[4]	0x80140307[4]	0x80140338[4]	0x80140340[4]	0x80140304[4]
PA[5]	0x80140300[5]	0x80140307[5]	0x80140338[5]	0x80140340[5]	0x80140304[5]
PA[6]	0x80140300[6]	0x80140307[6]	0x80140338[6]	0x80140340[6]	0x80140304[6]
PA[7]	0x80140300[7]	0x80140307[7]	0x80140338[7]	0x80140340[7]	0x80140304[7]
PB[0]	0x80140308[0]	0x8014030f[0]	0x80140339[0]	0x80140341[0]	0x8014030c[0]
PB[1]	0x80140308[1]	0x8014030f[1]	0x80140339[1]	0x80140341[1]	0x8014030c[1]
PB[2]	0x80140308[2]	0x8014030f[2]	0x80140339[2]	0x80140341[2]	0x8014030c[2]
PB[3]	0x80140308[3]	0x8014030f[3]	0x80140339[3]	0x80140341[3]	0x8014030c[3]
PB[4]	0x80140308[4]	0x8014030f[4]	0x80140339[4]	0x80140341[4]	0x8014030c[4]
PB[5]	0x80140308[5]	0x8014030f[5]	0x80140339[5]	0x80140341[5]	0x8014030c[5]
PB[6]	0x80140308[6]	0x8014030f[6]	0x80140339[6]	0x80140341[6]	0x8014030c[6]
PB[7]	0x80140308[7]	0x8014030f[7]	0x80140339[7]	0x80140341[7]	0x8014030c[7]
PC[0]	0x80140310[0]	0x80140317[0]	0x8014033a[0]	0x80140342[0]	0x80140314[0]

Pad	Input	IRQ	M0	M1	Polarity
PC[1]	0x80140310[1]	0x80140317[1]	0x8014033a[1]	0x80140342[1]	0x80140314[1]
PC[2]	0x80140310[2]	0x80140317[2]	0x8014033a[2]	0x80140342[2]	0x80140314[2]
PC[3]	0x80140310[3]	0x80140317[3]	0x8014033a[3]	0x80140342[3]	0x80140314[3]
PC[4]	0x80140310[4]	0x80140317[4]	0x8014033a[4]	0x80140342[4]	0x80140314[4]
PC[5]	0x80140310[5]	0x80140317[5]	0x8014033a[5]	0x80140342[5]	0x80140314[5]
PC[6]	0x80140310[6]	0x80140317[6]	0x8014033a[6]	0x80140342[6]	0x80140314[6]
PC[7]	0x80140310[7]	0x80140317[7]	0x8014033a[7]	0x80140342[7]	0x80140314[7]
PD[0]	0x80140318[0]	0x8014031f[0]	0x8014033b[0]	0x80140343[0]	0x8014031c[0]
PD[1]	0x80140318[1]	0x8014031f[1]	0x8014033b[1]	0x80140343[1]	0x8014031c[1]
PD[2]	0x80140318[2]	0x8014031f[2]	0x8014033b[2]	0x80140343[2]	0x8014031c[2]
PD[3]	0x80140318[3]	0x8014031f[3]	0x8014033b[3]	0x80140343[3]	0x8014031c[3]
PD[4]	0x80140318[4]	0x8014031f[4]	0x8014033b[4]	0x80140343[4]	0x8014031c[4]
PD[5]	0x80140318[5]	0x8014031f[5]	0x8014033b[5]	0x80140343[5]	0x8014031c[5]
PD[6]	0x80140318[6]	0x8014031f[6]	0x8014033b[6]	0x80140343[6]	0x8014031c[6]
PD[7]	0x80140318[7]	0x8014031f[7]	0x8014033b[7]	0x80140343[7]	0x8014031c[7]
PE[0]	0x80140320[0]	0x80140327[0]	0x8014033c[0]	0x80140344[0]	0x80140324[0]
PE[1]	0x80140320[1]	0x80140327[1]	0x8014033c[1]	0x80140344[1]	0x80140324[1]
PE[2]	0x80140320[2]	0x80140327[2]	0x8014033c[2]	0x80140344[2]	0x80140324[2]
PE[3]	0x80140320[3]	0x80140327[3]	0x8014033c[3]	0x80140344[3]	0x80140324[3]
PE[4]	0x80140320[4]	0x80140327[4]	0x8014033c[4]	0x80140344[4]	0x80140324[4]
PE[5]	0x80140320[5]	0x80140327[5]	0x8014033c[5]	0x80140344[5]	0x80140324[5]
PE[6]	0x80140320[6]	0x80140327[6]	0x8014033c[6]	0x80140344[6]	0x80140324[6]
PE[7]	0x80140320[7]	0x80140327[7]	0x8014033c[7]	0x80140344[7]	0x80140324[7]
PF[0]	0x80140328 [0]	0x8014032f[0]	0x8014033d[0]	0x80140345[0]	0x8014032c[0]
PF[1]	0x80140328[1]	0x8014032f[1]	0x8014033d[1]	0x80140345[1]	0x8014032c[1]
PF[2]	0x80140328[2]	0x8014032f[2]	0x8014033d[2]	0x80140345[2]	0x8014032c[2]
PF[3]	0x80140328[3]	0x8014032f[3]	0x8014033d[3]	0x80140345[3]	0x8014032c[3]
PF[4]	0x80140328[4]	0x8014032f[4]	0x8014033d4	0x80140345[4]	0x8014032c[4]

Pad	Input	IRQ	M0	M1	Polarity
PF[5]	0x80140328[5]	0x8014032f[5]	0x8014033d[5]	0x80140345[5]	0x8014032c[5]
PF[6]	0x80140328[6]	0x8014032f[6]	0x8014033d[6]	0x80140345[6]	0x8014032c[6]
PF[7]	0x80140328[7]	0x8014032f[7]	0x8014033d[7]	0x80140345[7]	0x8014032c[7]
PG[0]	0x80140330[0]	-	-	-	0x80140334[0]
PG[1]	0x80140330[1]	-	-	-	0x80140334[1]
PG[2]	0x80140330[2]	-	-	-	0x80140334[2]
PG[3]	0x80140330[3]	-	-	-	0x80140334[3]
PG[4]	0x80140330[4]	-	-	-	0x80140334[4]
PG[5]	0x80140330[5]	-	-	-	0x80140334[5]

11.1.7 GPIO GROUP IRQ Signal

Select GPIO GROUP interrupt trigger edge (positive edge or negative edge) via configuring "Polarity", and select a set of GPIO as interrupt source via configuring "gpio_group_sel".

11.1.8 Pull-up/Pull-down Resistors

All GPIOs support configurable pull-up resistor of rank x1 and x100 or pull-down resistor of rank x10 which are all disabled by default. Analog registers afe_0x0e<7:0> ~ afe_0x17<7:0> serve to control the pull-up/pull-down resistor for each GPIO, as shown in table below.

NOTE: The GPIO pull-up/pull-down resistance is a simulation result by the internal MOSFET and affected by the IO voltage VDDO3. The lower the IO voltage of GPIO, the higher the pull-up/pull-down resistance of GPIO.

Table 11-6 Analog Registers for Pull-up/Pull-down Resistor Control

Address	Type	Description	Default Value
0x0e	R/W	GPIO_A<3:0> pull up and down select: 00: Null 01: 1M pull up 10: 100K pull down 11: 10K pull up	00000000
0x0f	R/W	GPIO_A<7:4> pull up and down select: 00: Null 01: 1M pull up 10: 100K pull down 11: 10K pull up	00000000

Address	Type	Description	Default Value
0x10	R/W	GPIO_B<3:0> pull up and down select: 00: Null 01: 1M pull up 10: 100K pull down 11: 10K pull up	00000000
0x11	R/W	GPIO_B<7:4> pull up and down select: 00: Null 01: 1M pull up 10: 100K pull down 11: 10K pull up	00000000
0x12	R/W	GPIO_C<3:0> pull up and down select: 00: Null 01: 1M pull up 10: 100K pull down 11: 10K pull up	00000000
0x13	R/W	GPIO_C<7:4> pull up and down select: 00: Null 01: 1M pull up 10: 100K pull down 11: 10K pull up	00000000
0x14	R/W	GPIO_D<3:0> pull up and down select: 00: Null 01: 1M pull up 10: 100K pull down 11: 10K pull up	00000000
0x15	R/W	GPIO_D<7:4> pull up and down select: 00: Null 01: 1M pull up 10: 100K pull down 11: 10K pull up	00000000

Address	Type	Description	Default Value
0x16	R/W	GPIO_E<3:0> pull up and down select: 00: Null 01: 1M pull up 10: 100K pull down 11: 10K pull up	00000000
0x17	R/W	GPIO_E<7:4> pull up and down select: 00: Null 01: 1M pull up 10: 100K pull down 11: 10K pull up	00000000

11.1.9 GPIO Driving LED Description

The LED for RGB (Red, Green, Blue) can be driven by GPIO, the application principle is as follows.

1. Through the three states of output high / output low / input high resistance of the GPIO to drive the LED on and off respectively (no simultaneous bright state);
2. Control LED brightness by 2 resistors.

Figure 11-5 One GPIO drives two LEDs

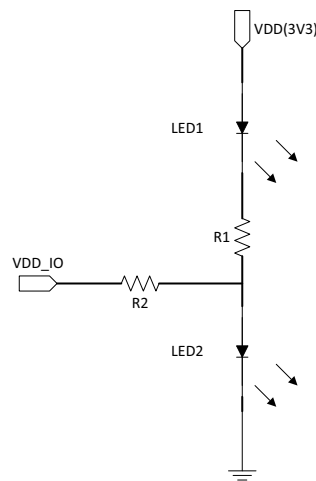

11.2 Swire

The SoC supports Single Wire Slave interface. SWM (Single Wire Master) and SWS (Single Wire Slave) represent the master and slave device of the single wire communication system developed by Telink. The maximum data rate can be up to 2 Mbps.

SWS usage is not supported in power-saving mode (deep sleep or suspend).

SWS related registers are listed as following, the base address of the following registers is 0x80100c00.

Table 11-7 Swire Related Registers

Offset	Type	Description	Default Value
0x00	R	SWIRE_DATA [7:0] swire_data	0x00
0x01	RW	SWIRE_CTL [0]:swire_wr [1]:swire_rd [2]:swire_cmd [4]:swire_eop [6]:swire_usb_det [7]:swire_usb_en	0x80
0x02	RW	SWIRE_CTL2 [6:0]: swire_clk_div	0x05
0x03	RW	SWIRE_ID [4:0] id_valid [7] fifo_mode	0x00

11.3 JTAG and SDP

This SoC has debug interfaces of JTAG and SDP. JTAG (Joint Test Action Group) is an interface used for debugging and programming the chip, and it includes four wires (TDI, TDO, TMS and TCK) for this SoC. SDP is a two-wire serial debug interface, which is multiplexed with TCK and TMS.

The specific GPIOs used as JTAG and SDP can be referred to the [Table 11-1 GPIO Pad Function Mux](#).

The bootstrap pin for switching between JTAG and SDP is PB[0] with the following definition:

- PB[0] is high (with pull-up): SDP is enabled;
- PB[0] is low (with pull-down): JTAG is enabled.

When power on after wake up from deep sleep mode, the SoC will read the voltage level of bootstrap pin and decide the debug port. This bootstrap pin cannot be modified through the init process or register.

11.4 I2C

The SoC embeds I2C hardware module, which could act as Master mode or Slave mode. I2C is a popular inter-IC interface requiring only 2 bus lines, a serial data line (SDA) and a serial clock line (SCL).

There are two channels of I2C signals in this chip. When the multiplexed GPIO pins are configured as I2C_SDA and I2C_SCL, they can work in Master and Slave mode; when the multiplexed GPIO pins are configured as I2C1_SCL and I2C1_SDA, they can work in Master mode only.

11.4.1 Communication Protocol

Telink I2C module supports standard mode (100kbps) and Fast-mode (400kbps) with restriction that system clock must be by at least 10x of data rate.

Two wires, SDA and SCL (SCK) carry information between Master device and Slave device connected to the bus. Each device is recognized by unique address (ID). Master device is the device which initiates a data transfer on the bus and generates the clock signals to permit that transfer. Slave device is the device addressed by a Master.

Both SDA and SCL are bidirectional lines connected to a positive supply voltage via a pull-up resistor. It's recommended to use external 3.3kOhm pull-up resistor. For standard mode, the internal pull-up resistor of rank x1 can be used instead of the external 3.3 kOhm pull-up.

When the bus is free, both lines are HIGH. It's noted that data in SDA line must keep stable when clock signal in SCL line is at high level, and level state in SDA line is only allowed to change when clock signal in SCL line is at low level.

Figure 11-6 I2C Timing

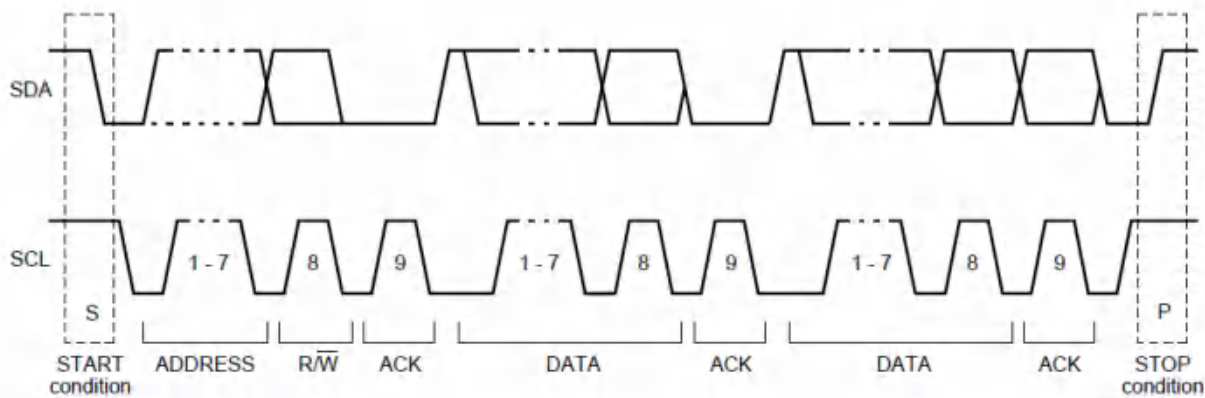

11.4.2 I2C Slave Mode

I2C module acts as Slave mode by default. I2C slave address can be configured via register I2C_ID (address 0x01) [7:1], as shown below.

Figure 11-7 Byte Consisted of Slave Address and R/W Flag Bit

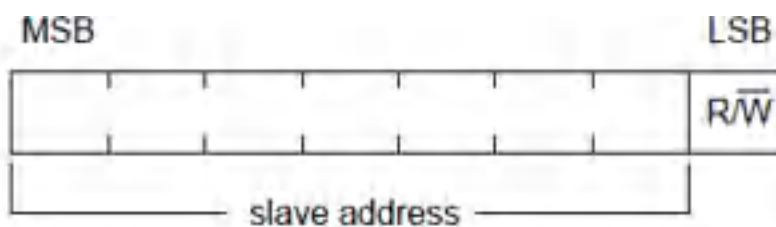

I2C slave mode supports two sub modes including Direct Memory Access (DMA) mode and No direct Memory Access (NDMA).

In I2C Slave mode, Master could initiate transaction anytime. I2C slave module will reply with ACK automatically. To monitor the start of I2C transaction, user could set interrupt from GPIO for SCA or SCL.

Read and write format of Slave modes are shown as below.

DMA and NDMA access buffer through dma and ahb, respectively.

Figure 11-8 Read Format in Slave Mode

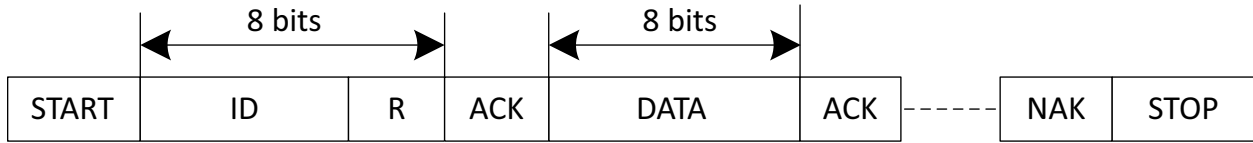
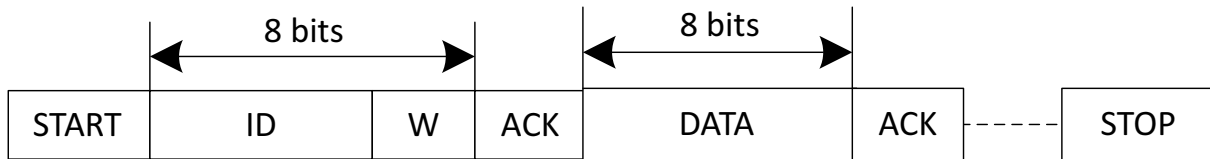

Figure 11-9 Write Format in Slave Mode



11.4.3 I2C Master Mode

Register I2CSCT0[1] should be set to 1'b1 to enable I2C master mode.

Register I2CSP sets I2C Master clock: $F_{I2C} = (\text{System Clock} / (4 * \text{clock speed configured in register I2CSP}))$.

A complete I2C protocol contains START, Slave Address, R/W bit, data, ACK and STOP. Slave address could be configured via I2C_ID [7:1].

I2C Master could send START, Slave Address, R/W bit, data and STOP cycle by configuring SLAVE_STRECH_EN. I2C master will send enabled cycles in the correct sequence.

Register I2CMST serves to indicate whether Master/Master packet is busy, as well as Master received status. Bit[0] will be set to 1 when one byte is being sent, and the bit can be automatically cleared after a start signal/address byte/acknowledge signal/data /stop signal is sent. Bit[1] is set to 1 when the start signal is sent, and the bit will be automatically cleared after the stop signal is sent. Bit[2] indicates whether to succeed in sending acknowledgement signal.

11.4.3.1 I2C Master Write Transfer in NDMA Mode

I2C Master has 8-byte buffer for write data, which are I2C_data_buf0, I2C_data_buf1, I2C_data_buf2 and I2C_data_buf3. Write transfer will be completed by I2C master module.

For example, to implement an I2C write transfer with 4-byte data, which contains START, Slave Address, Write bit, ACK from Slave, 1st byte, ACK from slave, 2nd byte, ACK from slave, 3rd byte, ACK from slave, 4th byte, ACK from slave and STOP, user needs to configure I2C slave address to I2C_ID[7:1], 1st byte address to buff. To start I2C write transfer, I2CSCT1 is configured to 0x13 (0001 0011). I2C Master will launch START, Slave address. 1 word data to buff; I2CSCT1 is configured to 0x24 (0000 0024). Write bit, load ACK to I2CMST[2], send buff data, load ACK to I2CMST[2] and then STOP sequentially.

I2C supports a single write of maximum length supported for a single DMA transfer.

11.4.3.2 I2C Master Read Transfer in NDMA Mode

I2C Master has 8 byte buffer for read data, which is fifo (0x08). Read transfer will be completed by I2C Master.

For example, to implement an I2C read transfer with 4 byte data, which contains START, Slave Address, Read bit, ACK from Slave, 4 byte from Slave, ACK by master and STOP, user needs to configure I2C slave address to I2C_ID[7:1]. To start I2C read transfer, I2CSCT1 is configured to 0x7b (0111 1011). I2C Master will launch

START, Slave address, Read bit, load ACK to I2CMST[2], load data to I2CDR, reply ACK and then STOP sequentially.

I2C supports a single read of maximum length supported for a single DMA transfer.

11.4.3.3 I2C Master Writer Transfer in DMA Mode

The data to be sent is put into SRAM, set tx dma config, user needs to configure I2C slave address to I2C_ID [7:1], 1st byte address to buff. To start I2C write transfer, I2CSCT1 is configured to 0x13 (0001 0011). I2C Master will launch START, Slave address. 1 word data to buff, I2CSCT1 is configured to 0x24 (0000 0024). Write bit, load ACK to I2CMST[2], send buff data, load ACK to I2CMST[2] and then STOP sequentially.

I2C supports a single write of maximum length supported for a single DMA transfer.

11.4.3.4 I2C Master Read Transfer in DMA Mode

For example, set rx dma config, user needs to configure I2C slave address to I2C_ID[7:1]. To start I2C read transfer, I2CSCT1 is configured to 0x7b (0111 1011). I2C Master will launch START, Slave address, Read bit, load ACK to I2CMST[2], load data to I2CDR, reply ACK and then STOP sequentially.

I2C supports a single write of maximum length supported for a single DMA transfer.

11.4.4 Register Description

The I2C related registers are listed as following, the base address of the following registers is 0x80140280.

Table 11-8 I2C Related Registers

Address Offset	Type	Description	Default Value
0x00	RW	I2CSP I2C master clock speed: $pclk * 1000 * 1000 / (4 * I2C_CLK_SPEED)$	0x1f
0x01	RW	I2C_ID I2C id: [7:1] I2C slave address + [0] R/W flag bit	0x5c
0x02	VOLATILE/R	I2CMST [0]: master busy (volatile) [1]: master packet busy (volatile) [2]: master received status: 1 for nak; 0 for ack (volatile) [5:3]: master state of the base: 0-ms_id, 1-ms_addr, 2-ms_dataw, 3-ms_datar, 4-ms_start, 5-ms_stop, 6-ms_idle (R) [7:6]: slave state of the base: 0-ss_id, 1-ss_dataw, 2-ss_datar (R)	0x30

Address Offset	Type	Description	Default Value
0x03	RW	I2CSCT0 [0]: I2C mask_slave_wr [1]: I2C mask_master_nak [2]: rx interrupt enable [3]: tx interrupt enable [4]: mask_txdone [5]: mask_rxdone [6]: mask_rxend [7]: mask_txend	0x00
0x04	RW	I2CSCT1 [0]: launch ID cycle [1]: launch address cycle [2]: launch data write cycle [3]: launch data read cycle [4]: launch start cycle [5]: launch stop cycle [6]: enable read ID [7]: enable ACK in read command	0x00
0x05	RW	I2CTRIG [3:0]: rx_irq_trig level [7:4]: tx_irq_trig level	0x44
0x06	RW	I2CCTRL2 [0]: I2C master enable [1]: r_clk_stretch_en, clk stretch enable: suspend transmission by pulling SCL down to low level, and continue transmission after SCL is released to high level [2]: manual_tx_stop_hit [3]: manual_rx_stop_hit [4]: nak_stop_en [5]: tx_stretch_sel [6]: mask_stretch [7]: hold0	0x00

Address Offset	Type	Description	Default Value
0x07	RW	I2CCTRL3 [0]: r_clk_stretch_sen, slave auto stretch clk enable [1]: hold1 [2]: r_ms_nak_en, the last byte data read is automatically returned to nack [3]: manual_sda_delay, delay sda and oen before ack (ID, ADDRESS, DATAW) [4]: ndma_rxdone_en, NDMA mode: rxdone function switch; 1:enable,0:disable;dma mode must disable [5]: auto_rxclr_en, DMA and ndma mode: auto clr function switch; 1:enable,0:disable [6]: r_hs_mode, standard mode and system clock 48M,maintain ss_scl setup time Max [7]: r_fast_mode, fast mode: ss_scl setup time Min	0x30
0x08	RW	I2C_DATA_BUF0 Write/read buffer[7:0]	0x00
0x09	RW	I2C_DATA_BUF1 Write/read buffer[15:8]	0x00
0x0a	RW	I2C_DATA_BUF2 Write/read buffer[23:16]	0x00
0x0b	RW	I2C_DATA_BUF3 Write/read buffer[31:24]	0x00
0x0c	VOLATILE	I2C_BUFCNT [3:0]: rx_buf_cnt [7:4]: tx_buf_cnt	0x00
0x0d	VOLATILE	I2C_STATUS [2:0]: rbcnt [0] W1C, manual_stretch_clr(manual clear slave stretch); [1] W1C, slave manul stretch clk trig; [2] W1C, manual_clr_mst_ack [3]: i2c_irq_o [6:4]: wbcnt [7]: rxdone	0x00

Address Offset	Type	Description	Default Value
0x0e	VOLATILE	I2C_STATUS1 [0]: ss_read, judge whether slave is to read or write [1]: ss_scl, slave stretch indicate [2]: tx_empty [3]: rx_full [6]: ss_scl_irq, W1C, manual_stretch_irq_clr (manual clear slave stretch irq)	0x06
0x0f	W1C	I2C_CLR [0]: ss_rw_clr, manual clear slave rw irq [1]: ms_nak_clr, manual clear master nak_irq [2]: rx_clr, rx manual fifo_clear [3]: tx_clr, tx manual fifo_clear [4]: rxdone_irq_clr, rxdone irq clr [5]: txdone_clr, tx_en(tx_done manual clear) [6]: rx_end_clr, manual clear rxend [7]: tx_end_clr, manual clear txend	0x00
0x10	RW	I2CLENL Config buffer send and receive byte number (low): default 1 byte	0x01
0x11	RW	I2CLENM Config buffer send and receive byte number (middle): default 0 byte	0x00
0x12	RW	I2CLENH Config buffer send and receive byte number (high): default 0 byte	0x00
0x13	R	I2C_MST_STATUS [0]: id_busy, nak function id flag [1]: addr_busy, nak function address flag [2]: dataw_busy, nak function wdata flag [3]: datar_busy, nak function rdata flag	0x00

11.5 I2S

11.5.1 Introduction

There are two completely independent I2S modules in this chip, which can be connected to the peripheral CODEC through GPIO configuration and support I2S0, I2S1 dual module synchronization and I2S synchronization mode between multiple chips, Master/Slave mode and 4-wire/5-wire mode.

This section briefly introduces some I2S protocols, as well as I2S module clock and some functional register configuration. As I2S0 and I2S1 are completely independent and the same in function, this chapter takes I2S0 as an example to introduce.

I2S features include:

- Supports master and slave mode
- Supports 4-wire/5-wire mode
- Supports 16 bits / 20 bits / 24 bits data width
- Supports sampling rate of less than or equal to 192 kHz
- Supports align mode

11.5.2 I2S Protocol

The I2S protocols include: I2S format, Left Justified (LJ) format, Right Justified (RJ) format, DSP format (mode A and mode B). The frame clock and MSB position of each format are listed as below.

Table 11-9 Frame Clock and MSB Position

Format	Frame Clock Mode	MSB Position from Start of Frame Clock
I2S	50% duty cycle	One bit clock delay
Left Justified	50% duty cycle	No delay
Right Justified	50% duty cycle	
DSP mode A	Single bit clock wide pulse	No delay
DSP mode B	Single bit clock wide pulse	One bit clock delay

Since the function of I2S0 and I2S1 are the same, here describes the function configuration of I2S taking I2S0 as an example.

- The supported I2S, LJ, RJ and DSP format is set by configuring register `i2s0_format` (0x80140501[1:0]);
- The data bit width of 16 bits, 20 bits, 24 bits is selected by configuring register `i2s_wl` (0x80140501[3:2]);
- The register `i2s0_lrp` (0x80140501[4]) is used to switch mode A and mode B in DSP format, and to reverse LRCLK in other format;
- The register `i2s0_lrswap` (0x80140501[5]) is used to reverse the data of left and right channels;

- The I2S module supports slave and master mode, by configuring register `i2s_adc_dci_ms` (0x80140501[6]) and `i2s_dac_dci_ms` (0x80140501[7]) these two bits to control the ADC/DAC master or slave mode;
- The I2S supports four/five wire mode, four wire refers to the ADC and DAC channel share a SLRCLK, configure `80140500[3:2]` to 2'b01 to set ADC and DAC paths to share the SLRCLK of DAC, configure `80140500[3:2]` for 2'b10 to set ADC and DAC paths to share the SLRCLK of ADC.

11.5.2.1 I2S Format

The timing sequence of I2S format is shown as below.

Figure 11-10 Timing Diagram of I2S Format

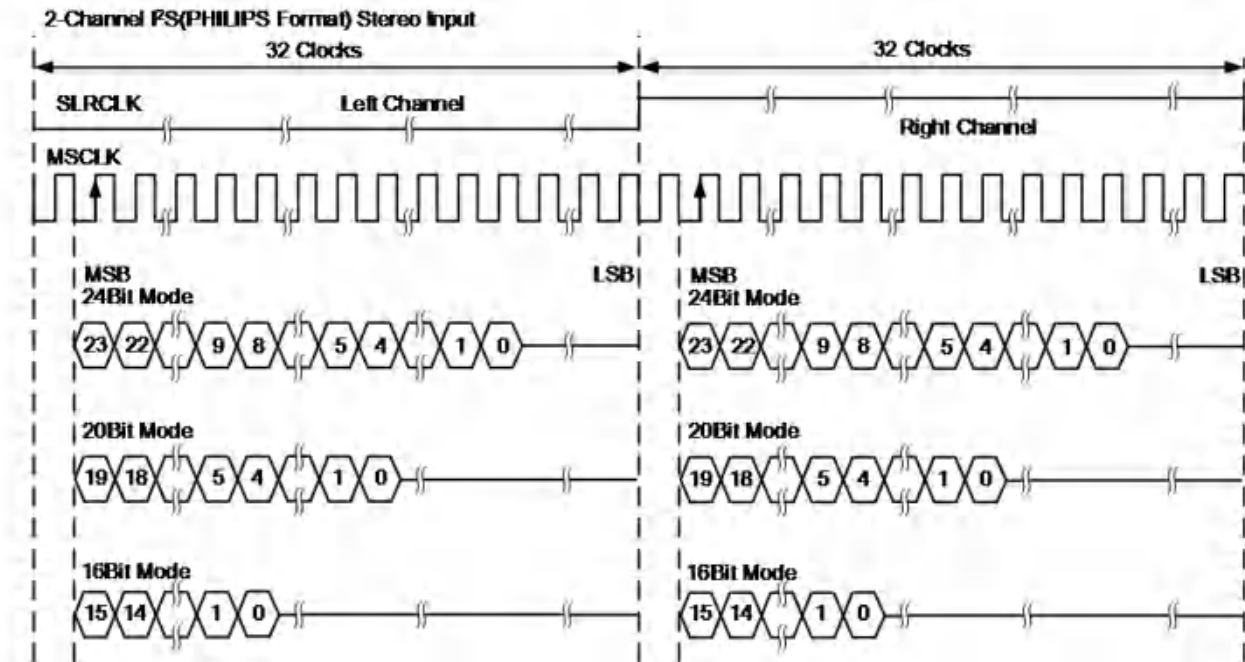

11.5.2.2 LJ Format

The timing sequence of LJ format is shown as below.

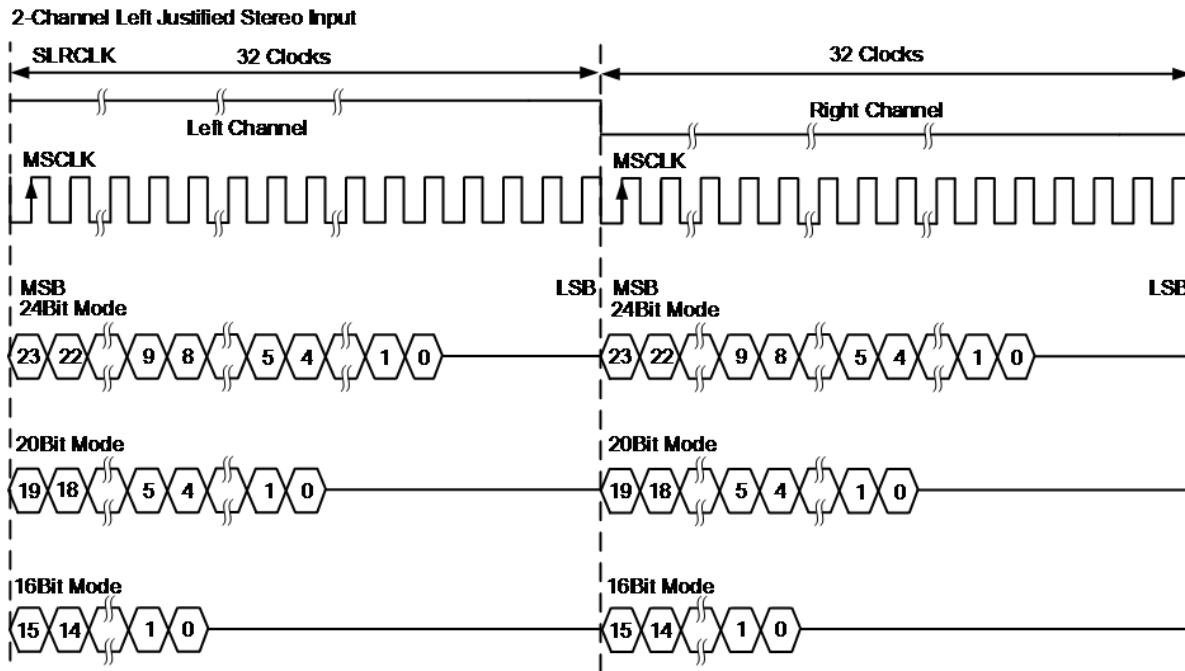
Figure 11-11 Timing Diagram of LJ Format

11.5.2.3 RJ Format

The timing sequence of RJ format is shown as below.

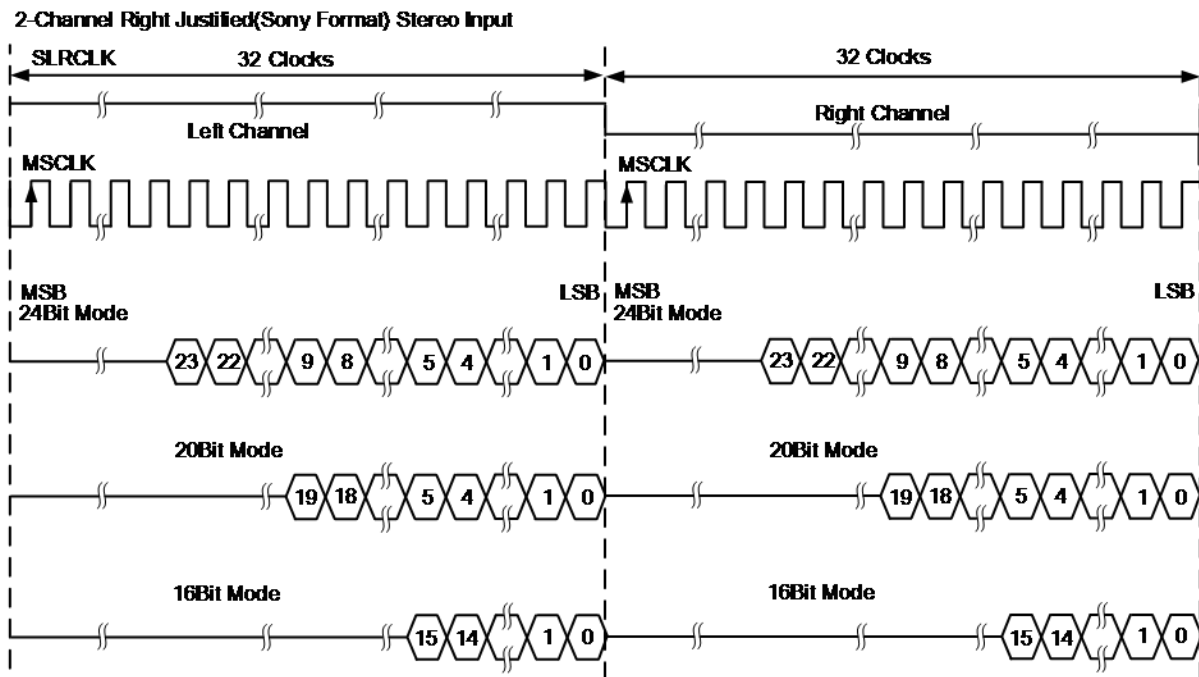
Figure 11-12 Timing Diagram of RJ Format

11.5.2.4 DSP Format (Mode A)

The timing sequence of DSP format mode A is shown as below.

Figure 11-13 Timing Diagram of DSP Format Mode A

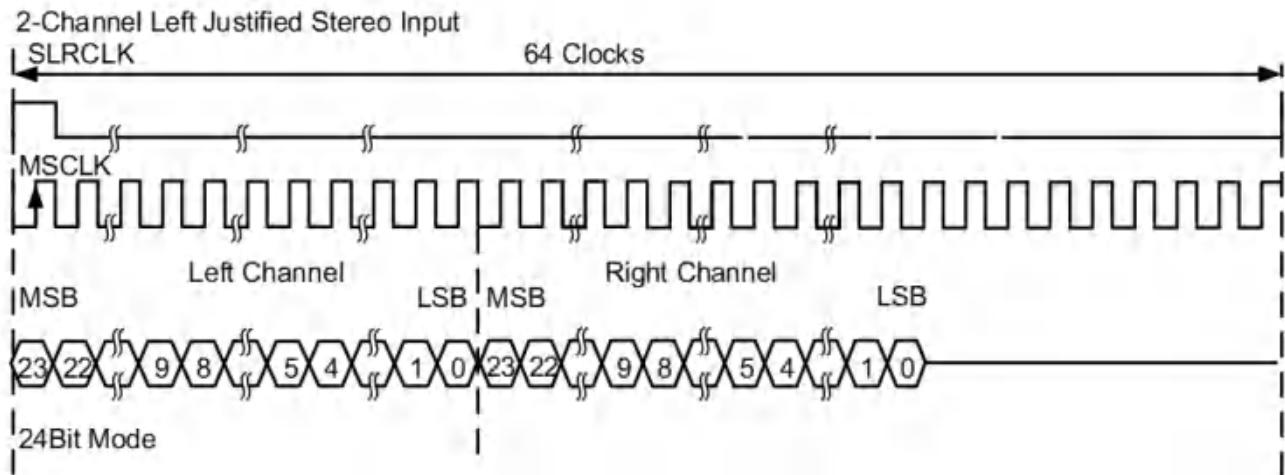

11.5.2.5 DSP Format (Mode B)

The timing sequence of DSP format mode B is shown as below.

Figure 11-14 Timing Diagram of DSP Format Mode B

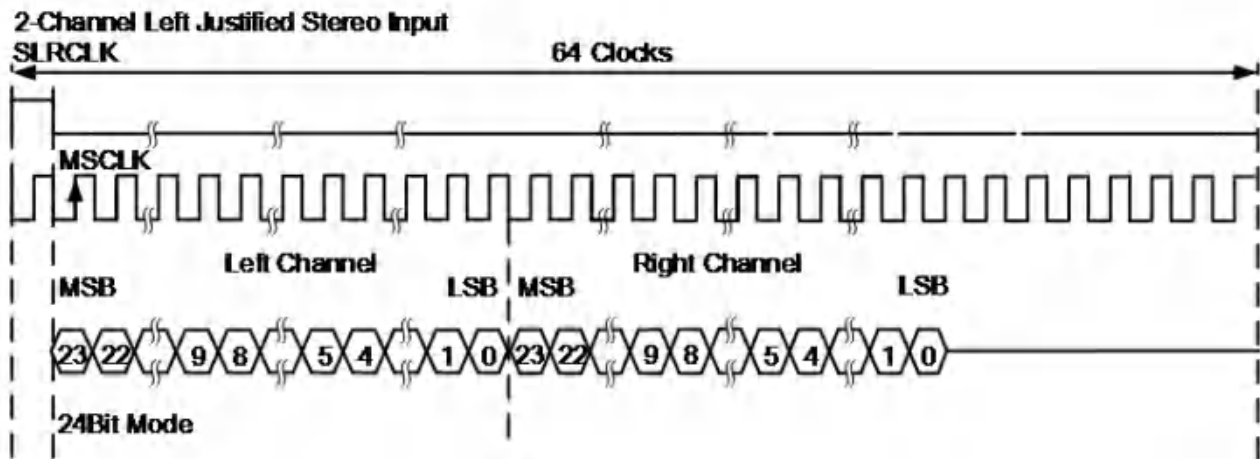

11.5.3 I2S Clock

Take the I2SO module as an example, the clock tree is shown in the figure below, in which clk_i2s0 is divided from pll.

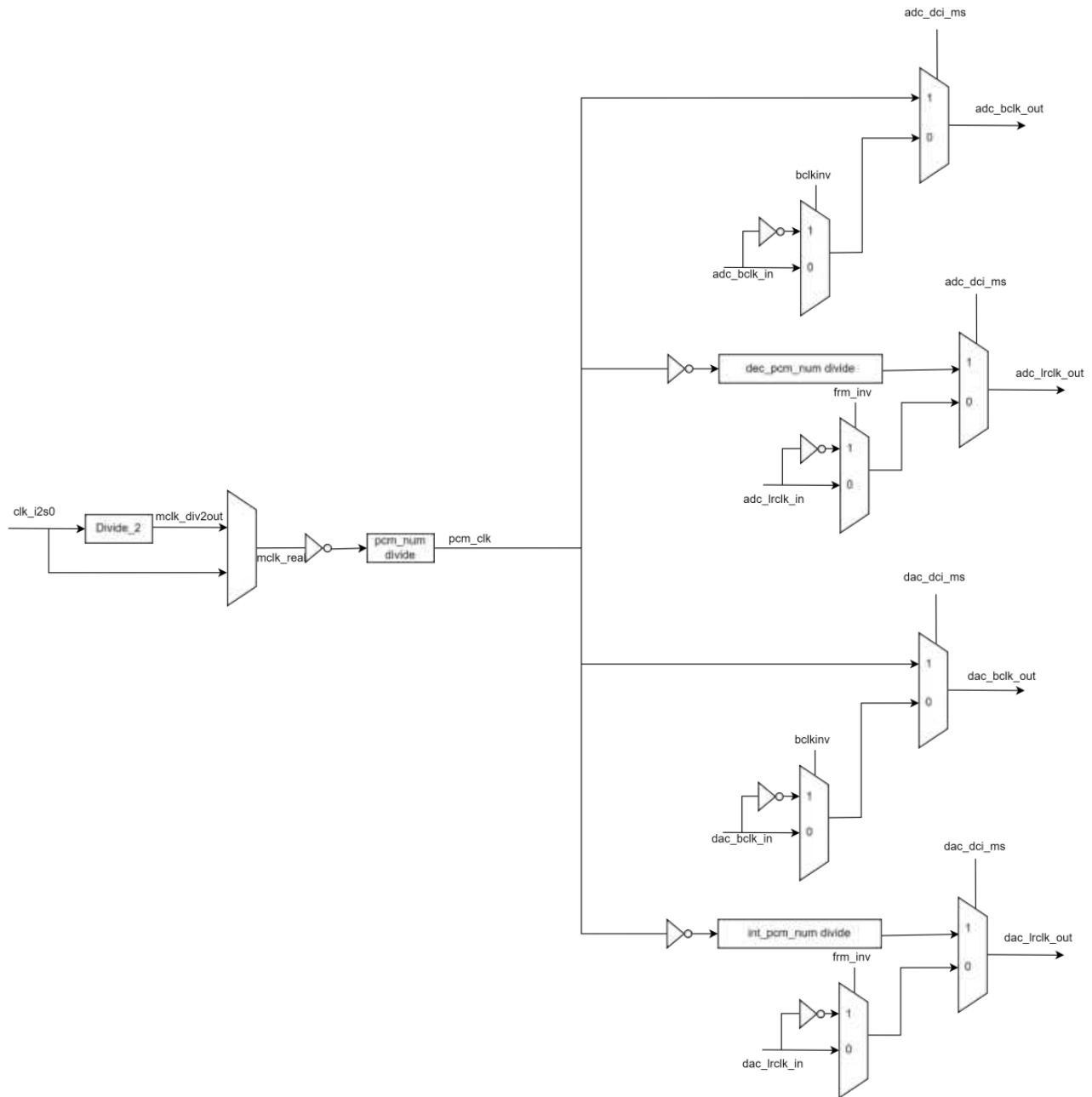
Figure 11-15 Clock Tree of I2S0 Module

- The `i2s0_clk_en(0x80140500[0])` is the I2S clock switch;
- We can choose whether to divide frequency for `clk_i2s0` by configuring `i2s0_clk_div2(0x80140500[1])`;
- When I2S module works as master (see above for registers), we can get bclk (bit clk) by configuring `i2s0_pcm_clk_num(0x80140554[3:0])`, which currently only supports even divisions (0, 2, 4...);
- We can get the lrclk (frame clk) from bclk dividing down by configuring `i2s0_int_pcm_num(0x80140550&0x80140551)` and `i2s0_dec_pcm_num(0x80140552&0x80140553)`, for example, bclk is 12 MHz. Currently if we want to configure lrclk as 48 kHz, configure `pcm_num` as 249 that is $48k=12M/(249+1)$; generally configure `pcm_num` as odd number to ensure lrclk has equal left and right width.

- In addition, in view of the external codec products have four-wire mode and five-wire mode, when the I2S module as a slave, according to demand configure `i2s0_mode` (0x80140500[3:2]) to switch four-wire or five-wire mode, and we can configure `bclkinv` (80140502[2]) and `frm_inv` (80140501[5]) to invert the input `bclk` and `lrclk`.

11.5.4 I2S Synchronization

Because of the need of external dual CODECs and the same phase, a dual I2S align mode is made in this chip.

- The register `i2s_align_en` (0x80140557[1]) is the general switch of I2S module align mode;
- The register `i2s_align_ctrl` (0x8014057[5:4]) is to control the align mode enable of `i2s0/i2s1` module respectively;
- The register `i2s_align_clk_sel` (0x80140557[2]) is to configure which `i2s` clock is shared by `i2s0/i2s1` module as the clock in align mode;
- The register `i2s_clk_sel`(0x80140557[3]) is to configure `i2s0/i2s1` module whether to use `i2s` align clock or their respective clock. The align clock is recommended as the clock for `i2s0/i2s1` in align mode.

The following figure shows the phase relationship between `i2s0_clk` and `i2s1_clk` before and after the alignment mode pairing.

Figure 11-16 Phase Relationship between `i2s0_clk` and `i2s1_clk`

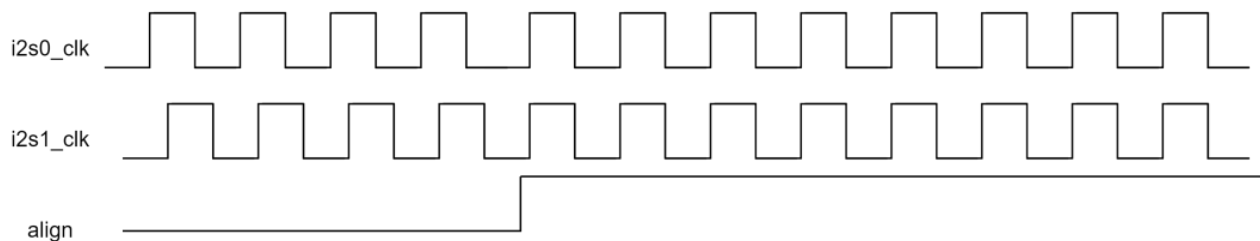

The usage of align mode in the order of configuration is described as below:

1. Configure the mode of I2S0 and I2S1, `i2s0_clk`, `i2s1_clk`;
2. Write `i2s_align_en` to 1 and write `i2s_align_ctrl` to 1;
3. Write `i2s_align_mask` (0x80140540[2]) to 0;
4. Set `i2s_timer_th` (0x8014055c-0x8014055f) threshold value to a reasonable value;
5. In align mode, the `sys_timer` gets the threshold of `i2s_timer_th` and triggers the `i2s0` and `i2s1` module.

The align mode can not only meet the `i2s0/i2s1` module synchronization within a chip, but also used to synchronize the I2S module between two (or more) chips; based on the operation of internal `i2s0/i2s1` synchronization, as long as the `sys_timer` tick of two chips are aligned, and by setting the threshold value of `i2s_timer_th`, to ensure that two chips trigger to generate the same phase clock at the same time, so as to achieve multi-chip I2S module phase synchronization.

In order to ensure that the same phase data generated by `i2s0/i2s1` can be accurately written to the SRAM, there is an align mode to match the data of `i2s0/i2s1` in DMA, which will be described in detail in section of Audio FIFO.

11.5.5 I2S Registers

The I2S related registers are listed as following, the base address of the following registers is 0x80140500.

Table 11-10 I2S Related Registers

Address Offset	Name	Type	Description	Default Value
0x00	I2S0_EN	R/W	[0]: i2s0_clk_en, i2s0 clk enable: 1'b1: enable; 1'b0: disable. [1]: i2s0_clk_div2, i2s0 clk divide2 enable: 1'b1: enable; 1'b0: disable. [3:2]: i2s0_mode, 2'b00: i2s0 5line mode; 2'b01: i2s0 4line dac mode; 2'b10: i2s0 4line adc mode [5:4]: i2s1_mode, 2'b00: i2s1 5line mode; 2'b01: i2s1 4line dac mode; 2'b10: i2s1 4line adc mode	0x00
0x01	I2S0_CFG1	R/W	[1:0]: i2s0_format, i2s0 format: 2'b00: RJ; 2'b01: LJ; 2'b10: I2S; 2'b11: DSP. [3:2]: i2s0_wl, i2s0 word length: 2'b00: 16; 2'b01: 20; 2'b10: 24 [4]: i2s0_lrp, DSP mode select when i2s DSP format or LRCLK invert operation: 1'b1: dsp mode B. 1'b0: dsp mode A. 1'b1: LRCLK invert; 1'b0: not invert [5]: i2s0_lrswap, i2s data swap. [6]: i2s0_adc_dci_ms, i2s0 adc as master. [7]: i2s0_dac_dci_ms, i2s0 dac as master.	0xca
0x02	I2S0_CFG2	R/W	[1:0]: i2s0_bcm_bits [2]: i2s0_bclkinv_o, bclk invert. [3]: rst_fifo0, manual reset fifo0 [4]: rst_fifo1, manual reset fifo1	0x00
0x30	I2S1_EN	R/W	[0]: i2s1_clk_en, i2s1 clk enable: 1'b1: enable; 1'b0: disable. [1]: i2s1_clk_div2, i2s1 clk divide2 enable: 1'b1: enable; 1'b0: disable.	0x00

Address Offset	Name	Type	Description	Default Value
0x31	I2S1_CFG1	R/W	[1:0]: i2s1_format, i2s1 format: 2'b00: RJ; 2'b01: LJ; 2'b10: I2S; 2'b11: DSP. [3:2]: i2s1_wl, i2s1 word length: 2'b00: 16; 2'b01: 20; 2'b10: 24 [4]: i2s1_lrp, DSP mode select when i2s DSP format or LRCLK invert operation: 1'b1: dsp mode A. 1'b0: dsp mode B. 1'b1: LRCLK invert; 1'b0: not invert [5]: i2s1_lrswap, i2s data swap. [6]: i2s1_adc_dci_ms, i2s1 adc as master. [7]: i2s1_dac_dci_ms, i2s1 dac as master.	0xca
0x36	I2S1_INT_PCM_NUM0	R/W	[7:0] i2s1_int_pcm_num0, dac i2s1 LRCLK counter low byte.	0x00
0x37	I2S1_INT_PCM_NUM1	R/W	[4:0] i2s1_int_pcm_num1, dac i2s1 LRCLK counter high byte.	0x00
0x38	I2S1_DEC_PCM_NUM0	R/W	[7:0] i2s1_dec_pcm_num0, adc i2s1 LRCLK counter low byte.	0x00
0x39	I2S1_DEC_PCM_NUM1	R/W	[4:0] i2s1_dec_pcm_num1, adc i2s1 LRCLK counter high byte.	0x00
0x3a	I2S1_PCM_CLK_NUM	R/W	[3:0] i2s1_pcm_clk_num, bclk division factor, i2s1_clk/(n*2).	0x00
0x50	I2S0_INT_PCM_NUM0	R/W	[7:0] i2s0_int_pcm_num0, dac i2s0 LRCLK counter low byte.	0x00
0x51	I2S0_INT_PCM_NUM1	R/W	[4:0] i2s0_int_pcm_num1, dac i2s0 LRCLK counter high byte.	0x00
0x52	I2S0_DEC_PCM_NUM0	R/W	[7:0] i2s0_dec_pcm_num0, adc i2s0 LRCLK counter low byte.	0x00
0x53	I2S0_DEC_PCM_NUM1	R/W	[4:0] i2s0_dec_pcm_num1, adc i2s0 LRCLK counter high byte.	0x00
0x54	I2S0_PCM_CLK_NUM	R/W	[3:0] i2s0_pcm_clk_num, bclk division factor, i2s0_clk/(n*2).	0x00
0x5c	I2S_TIMER_TH0	R/W	[7:0] i2s_timer_th0, i2s sys timer tick threshold 0 byte.	0xff
0x5d	I2S_TIMER_TH1	R/W	[7:0] i2s_timer_th1, i2s sys timer tick threshold 1 byte.	0xff

Address Offset	Name	Type	Description	Default Value
0x5e	I2S_TIMER_TH2	R/W	[7:0] i2s_timer_th2, i2s sys timer tick threshold 2 byte.	0xff
0x5f	I2S_TIMER_TH3	R/W	[7:0] i2s_timer_th3, i2s sys timer tick threshold 3 byte.	0x03

11.6 Memory SPI

11.6.1 Memory SPI Diagram

Memory SPI module is a controller which serves as a SPI master to access SPI flash. Features of memory SPI are listed as following:

- Supports SPI master mode
- Supports Dual line, Quad line and 3 line I/O SPI interface
- Supports XIP function
- Supports DMA transmission
- Supports DMA burst transmission, tx_dma up to burst4, rx_dma up to burst2
- Supports HW Crypto engine

The Memory SPI diagram is shown as below:

Figure 11-17 Memory SPI Diagram

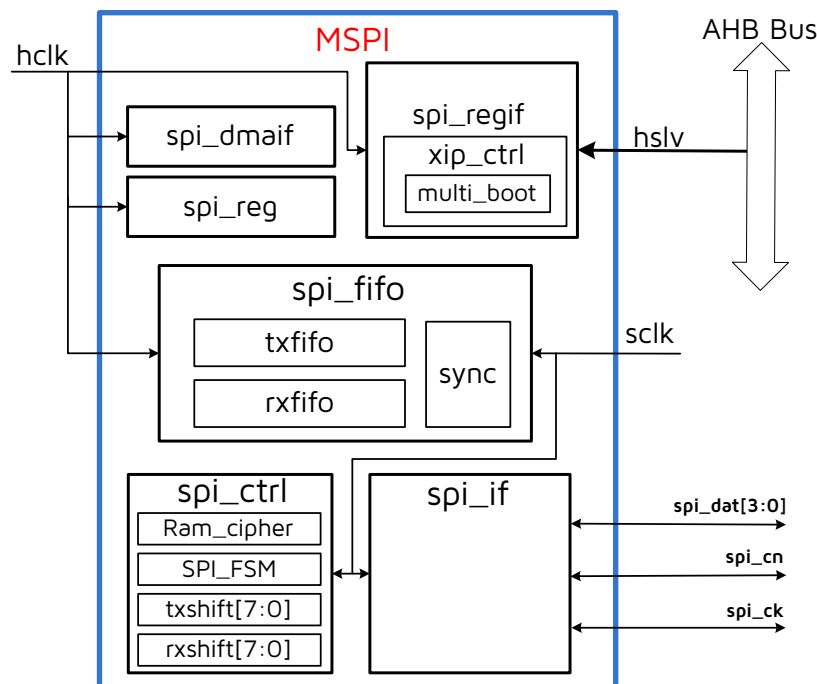

11.6.2 MSPI Register Description

Memory SPI related registers are listed as below. The base address of the following registers is 0xA3FFFF00.

Table 11-11 Memory SPI Related Registers

Offset	Type	Description	Default Value
0x00	RW	MSPI_WR_RD_DATA0 [7:0]: data[7:0] to transmit or received	0x00
0x01	RW	MSPI_WR_RD_DATA1 [7:0]: data[15:8] to transmit or received	0x00
0x02	RW	MSPI_WR_RD_DATA2 [7:0]: data[23:16] to transmit or received	0x00
0x03	RW	MSPI_WR_RD_DATA3 [7:0]: data[31:24] to transmit or received	0x00
0x04	RW	MSPI_CMD [7:0]: SPI Command	0x00
0x05	RW	MSPI_CTRL0 [2]: RXFIFOIntEn, enable the SPI Receive FIFO Threshold interrupt [3]: TXFIFOIntEn, enable the SPI Transmit FIFO Threshold interrupt [4]: EndIntEn, enable the End of SPI Transfer interrupt [6]: rx_dma_en, RX DMA enable [7]: tx_dma_en, TX DMA enable	0x00
0x07	RW	MSPI_TIMING [2:0] cs2sclk, the minimum time between the edge of SPI_CS and the edges of SPI_CLK. The actual duration is (SPI_CLK period*(cs2sclk+1)), MASTER ONLY [7:3] csht, the minimum time that SPI CS should stay HIGH. The actual duration is (SPI_CLK period*(csht+1)), MASTER ONLY	0x09
0x08	RW	MSPI_CTRL1 [1:0] data_lane, data lane, MASTER ONLY 0: single, 1: dual, 2: quad, 3: quad [3:2] addr_len, 2'b00:1byte 2'b01:2bytes 2'b10:3bytes 2'b11:4bytes, MASTER ONLY [4] addr_fmt, 0:single mode 1:the format of addr phase is the same as the data phase(Dual/Quad), MASTER ONLY [5] addr_en, 1:enabel addr phase, MASTER ONLY [6] cmd_fmt, 0: single mode 1: the format of the cmd phase is the same as the data phase(Dual/Quad), MASTER ONLY [7] cmd_en, the spi commnd phase enable, MASTER ONLY	0xa9

Offset	Type	Description	Default Value
0x09	RW	MSPI_CTRL2 [3:0] dummy_cnt, dummy number = {dummy_cnt_add, dummy_cnt} + 1 [7:4] transmode, the transfer mode the transfer sequence could be: 0x0: write and read at the same time (must enable CmdEn) 0x1: write only 0x2: read only (must enable CmdEn) 0x3: write, read 0x4: read, write 0x5: write, dummy, read 0x6: read, dummy, write (must enable CmdEn) 0x7: None Data (must enable CmdEn) 0x8: Dummy, write 0x9: Dummy, read 0xa~0xf: reserved	0x77
0x0c	RW	MSPI_ADDR0 [7:0] spi_addr0, spi address byte0, MASTER ONLY	0x0
0x0d	RW	MSPI_ADDR1 [7:0] spi_addr1, spi address byte1, MASTER ONLY	0x0
0x0e	RW	MSPI_ADDR2 [7:0] spi_addr2, spi address byte2, MASTER ONLY	0x0
0x0f	RW	MSPI_ADDR3 [7:0] spi_addr3, spi address byte3, MASTER ONLY	0x0
0x10	RW	MSPI_TX_CNT0 [7:0] tx_cnt0, transfer count for write data, byte0	0x00
0x11	RW	MSPI_TX_CNT1 [7:0] tx_cnt1, transfer count for write data, byte1	0x00
0x12	RW	MSPI_TX_CNT2 [7:0] tx_cnt2, transfer count for write data, byte2	0x00
0x14	RW	MSPI_RX_CNT0 [7:0] rx_cnt0, transfer count for read data, byte0	0x00

Offset	Type	Description	Default Value
0x15	RW	MSPI_RX_CNT1 [7:0] rx_cnt1, transfer count for read data, byte1	0x00
0x16	RW	MSPI_RX_CNT2 [7:0] rx_cnt2, transfer count for read data, byte2	0x00
0x18	RW	MSPI_CTRL3 [0] spi_lsb, transfer data with least significant bit first [1] spi_3line, MOSI is bi-directional signal in regular mode [3:2] spi_mode, spi_mode[0]:SPI_CLK Phase; spi_mode[1]:SPI_CLK Polarity [4] no_used [5] dmatx_sof_clrxfifo_en, auto clr txfifo when txdma start [6] dmarx_eof_clrrxfifo_en, auto clr rxfifo when rxdma end [7] auto_hready_en, auto control hready while access data register	0x90
0x19	RW	MSPI_TXFIFO_THRES [5:0] txfifo threshold	0x00
0x1a	RW	MSPI_RXFIFO_THRES [5:0] rxfifo threshold	0x00
0x1c	RW	MSPI_CTRL4 [0] xip_page_mode_en, xip page mode enable [1] xip_timeout_mode_en, 0:xip timeout disable 1:xip timeout enable [2] xip_stop, stop xip [3] xip_enable, enable xip [4] dummy_cnt_add	0x0a
0x1d	RW	MSPI_XIP_PAGE_SIZE [7:0] page_size, page boundary size = 2^page_size	0x00
0x1e	RW	MSPI_XIP_TIMEOUT_CNT [7:0] timeout_cnt, timeout time sel	0x20
0x20	RW	MSPI_SET_L [2:0] mspi_set_l, multiboot address offset option, 0:0k; 1:128k; 2:256k; 4:512k	0x00
0x21	RW	MSPI_SET_H [6:0] mspi_set_h, program space size = mspi_set_h*4k	0x00

Offset	Type	Description	Default Value
0x22	RW	MSPI_XIP_ADDR_OFFSET [7:0] xip_addr_offset, address offset = xip_addr_offset << 24	0x00
0x24	R	MSPI_TXFIFO_STATUS [6:0] txfifo_entries [7] txfifo_full	0x0
0x25	R	MSPI_RXFIFO_STATUS [6:0] rxfifo_entries [7] rxfifo_empty	0x0
0x28	RW/R	MSPI_STATUS [2] spi_soft_reset(RW), spi soft reset, high valid [3] xip_reg_arb_err(R), xip mode and reg mode conflict flag [4] rxfifo_clr_level(RW), rxfifo is in clear status [5] txfifo_clr_level(RW), txfifo is in clear status [7] busy(R), SPI is transferring	0x0
0x2a	W1C	MSPI_INT_STATUS0 [2] rxf_thres_int_stus, RX FIFO Threshold interrupt [3] txf_thres_int_stus, TX FIFO Threshold interrupt [4] trans_end_int_stus, End of SPI Transfer interrupt	0x00
0x90	RW	MSPI_XIP_RD_FMT [0] xip0_rd_data_dual, spi dual I/O mode, MASTER ONLY [1] xip0_rd_data_quad, spi quad I/O mode, MASTER ONLY [3:2] xip0_rd_addr_len, 2'b00:1bye 2'b01:2bytes 2'b10:3bytes 2'b11:4bytes [4] xip0_rd_addr_fmt, 0:single mode 1:the format of addr phase is the same as the data phase (Dual/Quad) [5] xip0_rd_addr_en, 1:enable addr phase, MASTER ONLY [6] xip0_rd_cmd_fmt, 0: single mode 1: the format of the cmd phase is the same as the data phase (Dual/Quad), MASTER ONLY [7] xip0_rd_cmd_en, the spi command phase enable, MASTER ONLY	0xa9
0x91	RW	MSPI_XIP_RD_TRANSMODE [3:0] xip0_rd_dummy_cnt, dummy number = dummy_cnt + 1 [7:4] xip0_rd_transmode	0x97

Offset	Type	Description	Default Value
0x93	RW	MSPI_XIP_RD_CMD [7:0] xip0_rd_cmd, read command used for xip	0x3b
0x94	RW	MSPI_XIP_WR_FMT [0] xip0_wr_data_dual, spi dual I/O mode, MASTER ONLY [1] xip0_wr_data_quad, spi quad I/O mode, MASTER ONLY [3:2] xip0_wr_addr_len, 2'b00:1bye 2'b01:2bytes 2'b10:3bytes 2'b11:4bytes [4] xip0_wr_addr_fmt, 0:single mode 1:the format of addr phase is the same as the data phase (Dual/Quad), MASTER ONLY [5] xip0_wr_addr_en, 1:enabel addr phase, MASTER ONLY [6] xip0_wr_cmd_fmt, 0: single mode 1: the format of the cmd phase is the same as the data phase (Dual/Quad), MASTER ONLY [7] xip0_wr_cmd_en, the spi command phase enable, MASTER ONLY	0xa8
0x95	RW	MSPI_XIP_WR_TRANSMODE [7:4] xip0_wr_transmode	0x10
0x97	RW	MSPI_XIP_WR_CMD [7:0] xip0_wr_cmd, write command used for xip	0x02

11.7 LSPI

11.7.1 LSPI Diagram

LSPI module is a controller which serves as a SPI master to access external LCD. Features of LSPI are listed as following:

- Supports SPI Master/Slave mode
- Supports Dual line, Quad line and 3 line I/O SPI interface
- Supports XIP function
- Supports DMA transmission
- Supports DMA burst transmission, tx_dma up to burst4, rx_dma up to burst2
- Supports LCD driving with SPI ports

The LSPI diagram is shown as below:

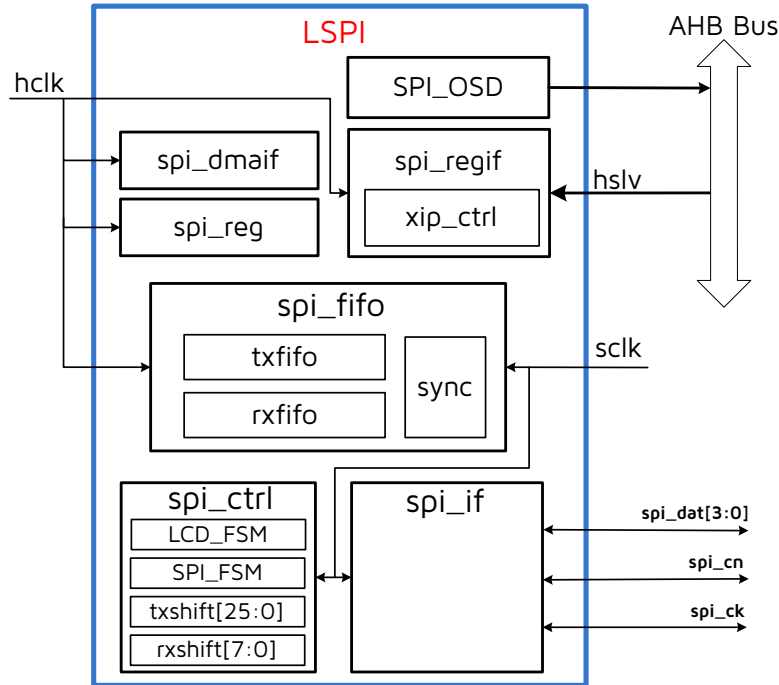
Figure 11-18 LSPI Diagram

11.7.2 LSPI Register Description

The LSPI related registers are listed as below. The base address of the following registers is 0x87FFFF00.

Table 11-12 LSPI Related Registers

Offset	Type	Description	Default Value
0x00	RW	LSPI_WR_RD_DATA0 [7:0]: data[7:0] to transmit or received	0x00
0x01	RW	LSPI_WR_RD_DATA1 [7:0]: data[15:8] to transmit or received	0x00
0x02	RW	LSPI_WR_RD_DATA2 [7:0]: data[23:16] to transmit or received	0x00
0x03	RW	LSPI_WR_RD_DATA3 [7:0]: data[31:24] to transmit or received	0x00
0x04	RW	LSPI_CMD [7:0]: SPI Command	0x00

Offset	Type	Description	Default Value
0x05	RW	LSPI_CTRL0 [0]: rxf_overnun_int_en, enable the SPI Receive FIFO Overrun interrupt, SLAVE ONLY [1]: txf_underrun_int_en, enable the SPI Transmit FIFO Underrun interrupt, SLAVE ONLY [2]: rxf_thres_int_en, enable the SPI Receive FIFO Threshold interrupt [3]: txf_thres_int_en, enable the SPI Transmit FIFO Threshold interrupt [4]: trans_end_int_en, enable the End of SPI Transfer interrupt [5]: slave_cmd_int_en, enable the Slave Command Interrupt, SLAVE ONLY [6]: rx_dma_en, RX DMA enable [7]: tx_dma_en, TX DMA enable	0x00
0x07	RW	LSPI_TIMING [2:0] cs2sclk, the minimum time between the edge of SPI_CS and the edges of SPI_CLK. The actual duration is (SPI_CLK period*(cs2sclk+1)), MASTER ONLY [7:3] csht, the minimum time that SPI CS should stay HIGH. The actual duration is (SPI_CLK period*(csht+1)), MASTER ONLY	0x09
0x08	RW	LSPI_CTRL1 [1:0] data_lane, data lane, MASTER ONLY 0: single, 1: dual, 2: quad, 3: quad [3:2] addr_len, 2'b00:1byte 2'b01:2bytes 2'b10:3bytes 2'b11:4bytes, MASTER ONLY [4] addr_fmt, 0:single mode 1:the format of addr phase is the same as the data phase(Dual/Quad), MASTER ONLY [5] addr_en, 1:enabel addr phase, MASTER ONLY [6] cmd_fmt, 0: single mode 1: the format of the cmd phase is the same as the data phase(Dual/Quad), MASTER ONLY [7] cmd_en, the spi commnd phase enable, MASTER ONLY	0xa9

Offset	Type	Description	Default Value
0x09	RW	LSPI_CTRL2 [3:0] dummy_cnt, dummy number = {dummy_cnt_add, dummy_cnt} + 1 [7:4] transmode, the transfer mode the transfer sequence could be: 0x0: write and read at the same time (must enable CmdEn) 0x1: write only 0x2: read only (must enable CmdEn) 0x3: write, read 0x4: read, write 0x5: write, dummy, read 0x6: read, dummy, write (must enable CmdEn) 0x7: None Data (must enable CmdEn) 0x8: Dummy, write 0x9: Dummy, read 0xa-0xf: reserved	0x77
0x0c	RW	LSPI_ADDR0 [7:0] spi_addr0, spi address byte0/lcd_porch_line_time[7:0]	0x0
0x0d	RW	LSPI_ADDR1 [7:0] spi_addr1, spi address byte1/lcd_porch_line_time[15:8]	0x0
0x0e	RW	LSPI_ADDR2 [7:0] spi_addr2, spi address byte2/lcd_display_line_time[7:0]	0x0
0x0f	RW	LSPI_ADDR3 [7:0] spi_addr3, spi address byte3/lcd_display_line_time[15:8]	0x0
0x10	RW	LSPI_TX_CNT0 [7:0] tx_cnt0, transfer count for write data, byte0/lcd_pixel_per_line[7:0]	0x00
0x11	RW	LSPI_TX_CNT1 [7:0] tx_cnt1, transfer count for write data, byte1/ {lcd_line_per_frame[5:0], lcd_pixel_per_line[9:8]}	0x00
0x12	RW	LSPI_TX_CNT2 [7:0] tx_cnt2, transfer count for write data, byte2/{4'h0, lcd_line_per_frame[9:6]}	0x00

Offset	Type	Description	Default Value
0x14	RW	LSPI_RX_CNT0 [7:0] rx_cnt0, transfer count for read data, byte0	0x00
0x15	RW	LSPI_RX_CNT1 [7:0] rx_cnt1, transfer count for read data, byte1	0x00
0x16	RW	LSPI_RX_CNT2 [7:0] rx_cnt2, transfer count for read data, byte2	0x00
0x18	RW	LSPI_CTRL3 [0] spi_lsb, transfer data with least significant bit first [1] spi_3line, MOSI is bi-directional signal in regular mode [3:2] spi_mode, spi_mode[0]:SPI_CLK Phase; spi_mode[1]:SPI_CLK Polarity [4] spi_master, SPI master mode selection [5] dmatx_sof_clrxfifo_en, auto clr txfifo when txdma start [6] dmarx_eof_clrxfifo_en, auto clr rxfifo when rxdma end [7] auto_hready_en, auto control hready while access data register	0x90
0x19	RW	LSPI_TXFIFO_THRES [5:0] txfifo threshold	0x00
0x1a	RW	LSPI_RXFIFO_THRES [5:0] rxfifo threshold	0x00
0x1c	RW	LSPI_CTRL4 [0] xip_page_mode_en, xip page mode enable [1] xip_timeout_mode_en, 0:xip timeout disable 1:xip timeout enable [2] xip_stop, stop xip [3] xip_enable, enable xip [4] dummy_cnt_add	0x0a
0x1d	RW	LSPI_XIP_PAGE_SIZE [7:0] page_size, page boundary size = $2^{\text{page_size}}$	0x00
0x1e	RW	LSPI_XIP_TIMEOUT_CNT [7:0] timeout_cnt, timeout time sel	0x20
0x22	RW	LSPI_XIP_ADDR_OFFSET [7:0] xip_addr_offset, address offset = $\text{xip_addr_offset} \ll 24$	0x00

Offset	Type	Description	Default Value
0x24	R	LSPI_TXFIFO_STATUS [6:0] txfifo_entries [7] txfifo_full	0x0
0x25	R	LSPI_RXFIFO_STATUS [6:0] rxfifo_entries [7] rxfifo_empty	0x0
0x28	RW/R	LSPI_STATUS [0] set_slave_ready(RW), set this bit to indicate that spi as slave is ready for data transaction [1] clr_slave_ready(RW), clear spi slave ready [2] spi_soft_reset(RW), spi soft reset, high valid [3] xip_reg_arb_err(R), xip mode and reg mode conflict flag [4] rxfifo_clr_level(RW), rxfifo is in clear status [5] txfifo_clr_level(RW), txfifo is in clear status [6] osd_ahbmst_busy(R), osd ahbmster is in busy status [7] busy(R), SPI is transferring	0x0
0x2a	W1C	LSPI_INT_STATUS0 [0] rxf_overnrun_int_stus, RX FIFO Overrun interrupt, SLAVE ONLY [1] txf_underrun_int_stus, TX FIFO Underrun interrpr, SLAVE ONLY [2] rxf_thres_int_stus, RX FIFO Threshold interrupt [3] txf_thres_int_stus, TX FIFO Threshold interrupt [4] trans_end_int_stus, End of SPI Transfer interrupt [5] slave_cmd_int_stus, Slave Command Interrupt, SLAVE ONLY	0x00
0x2b	W1C	LSPI_INT_STATUS1 [0] lcd_line_int_stus, lcd line interrupt status [1] lcd_lv1_int_stus, lcd line level interrupt status [2] lcd_frame_int_stus, lcd frame interrupt status	0x00
0x2f	RW	LSPI_LCD_CTRL2 [0] lcd_single_color_mode, 1: single color mode, use lut1 [1] lcd_rgb_big_endian_mode, 1:big endian mode; 0:little endian mode [2] lcd_ram_4bit_mode [5:3] lcd_int_mask, lcd interrupt mask, [3]: lcd_line_irq_mask [4]: lcd_line_lv1_irq_mask [5]: lcd_frame_irq_mask	0x00

Offset	Type	Description	Default Value
0x30	RW	LSPI_LCD_CTRL [0] lcd_scan_en, scan lcd enable [2:1] lcd_rgb_mode, 0:rsvd; 1:565; 2:666; 3:888 [3] lcd_2lane_en, 1: 2 data lane enable in ram lcd mode [6] line3_dcx_en, 1:enable 3line mode [7] dcx, 1:set dcx filed to 1	0x00
0x31	RW	LSPI_LCD_VBP_CNT [7:0] lcd_vbp_cnt, lcd vertical porch line number, actual num=lcd_vbp_cnt	0x00
0x32	RW	LSPI_LCD_VFP_CNT [7:0] lcd_vfp_cnt, lcd front porch line number, actual num=lcd_vbp_cnt	0x00
0x33	RW	LSPI_LCD_LINE_LVL [7:0] lcd_line_lvl, lcd line threshold to trig interrupt	0x00
0x34	RW	LSPI_LCD_BIMAGE_ADDR0 [7:5] lcd_bimage_start_addr0, background image data start address byte0	0x00
0x35	RW	LSPI_LCD_BIMAGE_ADDR1 [7:0] lcd_bimage_start_addr1, background image data start address byte1	0x00
0x36	RW	LSPI_LCD_BIMAGE_ADDR2 [7:0] lcd_bimage_start_addr2, background image data start address byte2	0x00
0x37	RW	LSPI_LCD_BIMAGE_ADDR3 [6:0] lcd_bimage_start_addr3, background image data start address byte3	0x00
0x38	RW	LSPI_LCD_FIMAGE_ADDR0 [7:4] lcd_fimage_start_addr0, front image data start address byte0	0x00
0x39	RW	LSPI_LCD_FIMAGE_ADDR1 [7:0] lcd_fimage_start_addr0, front image data start address byte1	0x00
0x3a	RW	LSPI_LCD_FIMAGE_ADDR2 [7:0] lcd_fimage_start_addr0, front image data start address byte2	0x00
0x3b	RW	LSPI_LCD_FIMAGE_ADDR2 [6:0] lcd_fimage_start_addr0, front image data start address byte3	0x00
0x3e	R	LSPI_LCD_LINE_CNT0 [7:0] lcd_line_cnt_l, lcd_line_cnt[7:0]	0x00

Offset	Type	Description	Default Value
0x3f	R	LSPI_LCD_LINE_CNT1 [1:0] lcd_line_cnt_l, lcd_line_cnt[9:8]	0x00
0x40	RW	LSPI_LCD_LUT_DATA0_BYTE0 [7:0] lcd_lut_data0_byte0, lcd lut address0 data byte0	0x00
0x41	RW	LSPI_LCD_LUT_DATA0_BYTE1 [7:0] lcd_lut_data0_byte1, lcd lut address0 data byte1	0x00
0x42	RW	LSPI_LCD_LUT_DATA0_BYTE2 [7:0] lcd_lut_data0_byte2, lcd lut address0 data byte2	0x00
0x44	RW	LSPI_LCD_LUT_DATA1_BYTE0 [7:0] lcd_lut_data1_byte0, lcd lut address1 data byte0	0x00
0x45	RW	LSPI_LCD_LUT_DATA1_BYTE1 [7:0] lcd_lut_data1_byte1, lcd lut address1 data byte1	0x00
0x46	RW	LSPI_LCD_LUT_DATA1_BYTE2 [7:0] lcd_lut_data1_byte2, lcd lut address1 data byte2	0x00
0x48	RW	LSPI_LCD_LUT_DATA2_BYTE0 [7:0] lcd_lut_data2_byte0, lcd lut address2 data byte0	0x00
0x49	RW	LSPI_LCD_LUT_DATA2_BYTE1 [7:0] lcd_lut_data2_byte0, lcd lut address2 data byte1	0x00
0x4a	RW	LSPI_LCD_LUT_DATA2_BYTE2 [7:0] lcd_lut_data2_byte0, lcd lut address2 data byte2	0x00
0x4c	RW	LSPI_LCD_LUT_DATA3_BYTE0 [7:0] lcd_lut_data3_byte0, lcd lut address3 data byte0	0x00
0x4d	RW	LSPI_LCD_LUT_DATA3_BYTE1 [7:0] lcd_lut_data3_byte0, lcd lut address3 data byte1	0x00
0x4e	RW	LSPI_LCD_LUT_DATA3_BYTE2 [7:0] lcd_lut_data3_byte0, lcd lut address3 data byte2	0x00
0x50	RW	LSPI_LCD_LUT_DATA4_BYTE0 [7:0] lcd_lut_data4_byte0, lcd lut address4 data byte0	0x00
0x51	RW	LSPI_LCD_LUT_DATA4_BYTE1 [7:0] lcd_lut_data4_byte0, lcd lut address4 data byte1	0x00

Offset	Type	Description	Default Value
0x52	RW	LSPI_LCD_LUT_DATA4_BYTE2 [7:0] lcd_lut_data4_byte0, lcd lut address4 data byte2	0x00
0x54	RW	LSPI_LCD_LUT_DATA5_BYTE0 [7:0] lcd_lut_data5_byte0, lcd lut address5 data byte0	0x00
0x55	RW	LSPI_LCD_LUT_DATA5_BYTE1 [7:0] lcd_lut_data5_byte0, lcd lut address5 data byte1	0x00
0x56	RW	LSPI_LCD_LUT_DATA5_BYTE2 [7:0] lcd_lut_data5_byte0, lcd lut address5 data byte2	0x00
0x58	RW	LSPI_LCD_LUT_DATA6_BYTE0 [7:0] lcd_lut_data6_byte0, lcd lut address6 data byte0	0x00
0x59	RW	LSPI_LCD_LUT_DATA6_BYTE1 [7:0] lcd_lut_data6_byte0, lcd lut address6 data byte1	0x00
0x5a	RW	LSPI_LCD_LUT_DATA6_BYTE2 [7:0] lcd_lut_data6_byte0, lcd lut address6 data byte2	0x00
0x5c	RW	LSPI_LCD_LUT_DATA7_BYTE0 [7:0] lcd_lut_data7_byte0, lcd lut address7 data byte0	0x00
0x5d	RW	LSPI_LCD_LUT_DATA7_BYTE1 [7:0] lcd_lut_data7_byte0, lcd lut address7 data byte1	0x00
0x5e	RW	LSPI_LCD_LUT_DATA7_BYTE2 [7:0] lcd_lut_data7_byte0, lcd lut address7 data byte2	0x00
0x60	RW	LSPI_LCD_LUT_DATA8_BYTE0 [7:0] lcd_lut_data8_byte0, lcd lut address8 data byte0	0x00
0x61	RW	LSPI_LCD_LUT_DATA8_BYTE1 [7:0] lcd_lut_data8_byte0, lcd lut address8 data byte1	0x00
0x62	RW	LSPI_LCD_LUT_DATA8_BYTE2 [7:0] lcd_lut_data8_byte0, lcd lut address8 data byte2	0x00
0x64	RW	LSPI_LCD_LUT_DATA9_BYTE0 [7:0] lcd_lut_data9_byte0, lcd lut address9 data byte0	0x00
0x65	RW	LSPI_LCD_LUT_DATA9_BYTE1 [7:0] lcd_lut_data9_byte0, lcd lut address9 data byte1	0x00

Offset	Type	Description	Default Value
0x66	RW	LSPI_LCD_LUT_DATA9_BYTE2 [7:0] lcd_lut_data9_byte0, lcd lut address9 data byte2	0x00
0x68	RW	LSPI_LCD_LUT_DATA10_BYTE0 [7:0] lcd_lut_data10_byte0, lcd lut address10 data byte0	0x00
0x69	RW	LSPI_LCD_LUT_DATA10_BYTE1 [7:0] lcd_lut_data10_byte0, lcd lut address10 data byte1	0x00
0x6a	RW	LSPI_LCD_LUT_DATA10_BYTE2 [7:0] lcd_lut_data10_byte0, lcd lut address10 data byte2	0x00
0x6c	RW	LSPI_LCD_LUT_DATA11_BYTE0 [7:0] lcd_lut_data11_byte0, lcd lut address11 data byte0	0x00
0x6d	RW	LSPI_LCD_LUT_DATA11_BYTE1 [7:0] lcd_lut_data11_byte0, lcd lut address11 data byte1	0x00
0x6e	RW	LSPI_LCD_LUT_DATA11_BYTE2 [7:0] lcd_lut_data11_byte0, lcd lut address11 data byte2	0x00
0x70	RW	LSPI_LCD_LUT_DATA12_BYTE0 [7:0] lcd_lut_data12_byte0, lcd lut address12 data byte0	0x00
0x71	RW	LSPI_LCD_LUT_DATA12_BYTE1 [7:0] lcd_lut_data12_byte0, lcd lut address12 data byte1	0x00
0x72	RW	LSPI_LCD_LUT_DATA12_BYTE2 [7:0] lcd_lut_data12_byte0, lcd lut address12 data byte2	0x00
0x74	RW	LSPI_LCD_LUT_DATA13_BYTE0 [7:0] lcd_lut_data13_byte0, lcd lut address13 data byte0	0x00
0x75	RW	LSPI_LCD_LUT_DATA13_BYTE1 [7:0] lcd_lut_data13_byte0, lcd lut address13 data byte1	0x00
0x76	RW	LSPI_LCD_LUT_DATA13_BYTE2 [7:0] lcd_lut_data13_byte0, lcd lut address13 data byte2	0x00
0x78	RW	LSPI_LCD_LUT_DATA14_BYTE0 [7:0] lcd_lut_data14_byte0, lcd lut address14 data byte0	0x00
0x79	RW	LSPI_LCD_LUT_DATA14_BYTE1 [7:0] lcd_lut_data14_byte0, lcd lut address14 data byte1	0x00

Offset	Type	Description	Default Value
0x7a	RW	LSPI_LCD_LUT_DATA14_BYTE2 [7:0] lcd_lut_data14_byte0, lcd lut address14 data byte2	0x00
0x7c	RW	LSPI_LCD_LUT_DATA15_BYTE0 [7:0] lcd_lut_data15_byte0, lcd lut address15 data byte0	0x00
0x7d	RW	LSPI_LCD_LUT_DATA15_BYTE1 [7:0] lcd_lut_data15_byte0, lcd lut address15 data byte1	0x00
0x7e	RW	LSPI_LCD_LUT_DATA15_BYTE2 [7:0] lcd_lut_data15_byte0, lcd lut address15 data byte2	0x00
0x90	RW	LSPI_XIP_RD_FMT [0] xip0_rd_data_dual, spi dual I/O mode, MASTER ONLY [1] xip0_rd_data_quad, spi quad I/O mode, MASTER ONLY [3:2] xip0_rd_addr_len, 2'b00:1byte 2'b01:2bytes 2'b10:3bytes 2'b11:4bytes [4] xip0_rd_addr_fmt, 0:single mode 1:the format of addr phase is the same as the data phase (Dual/Quad) [5] xip0_rd_addr_en, 1:enable addr phase, MASTER ONLY [6] xip0_rd_cmd_fmt, 0: single mode 1: the format of the cmd phase is the same as the data phase (Dual/Quad), MASTER ONLY [7] xip0_rd_cmd_en, the spi command phase enable, MASTER ONLY	0xa9
0x91	RW	LSPI_XIP_RD_TRANSMODE [3:0] xip0_rd_dummy_cnt, dummy number = dummy_cnt + 1 [7:4] xip0_rd_transmode, xip read transmode/lcd display transmode	0x97
0x93	RW	LSPI_XIP_RD_CMD [7:0] xip0_rd_cmd, read command used for xip	0x3b

Offset	Type	Description	Default Value
0x94	RW	LSPI_XIP_WR_FMT [0] xip0_wr_data_dual, spi dual I/O mode, MASTER ONLY [1] xip0_wr_data_quad, spi quad I/O mode, MASTER ONLY [3:2] xip0_wr_addr_len, 2'b00:1byte 2'b01:2bytes 2'b10:3bytes 2'b11:4bytes [4] xip0_wr_addr_fmt, 0:single mode 1:the format of addr phase is the same as the data phase (Dual/Quad), MASTER ONLY [5] xip0_wr_addr_en, 1:enabel addr phase, MASTER ONLY [6] xip0_wr_cmd_fmt, 0: single mode 1: the format of the cmd phase is the same as the data phase (Dual/Quad), MASTER ONLY [7] xip0_wr_cmd_en, the spi command phase enable, MASTER ONLY	0xa8
0x95	RW	LSPI_XIP_WR_TRANSMODE [7:4] xip0_wr_transmode, xip write transmode/lcd porch transmode	0x10
0x97	RW	LSPI_XIP_WR_CMD [7:0] xip0_wr_cmd, write command used for xip/lcd_cmd	0x02

11.8 GSPI

11.8.1 GSPI Diagram

The GSPI module is a controller which serves as a SPI master to access other general SPI interfaces. Features of GSPI are listed as following:

- Supports SPI Master/Slave mode
- Supports Dual line and 3 line I/O SPI interface
- Supports XIP function
- Supports DMA transmission
- Supports multi-chip selection function

The GSPI diagram is shown as following:

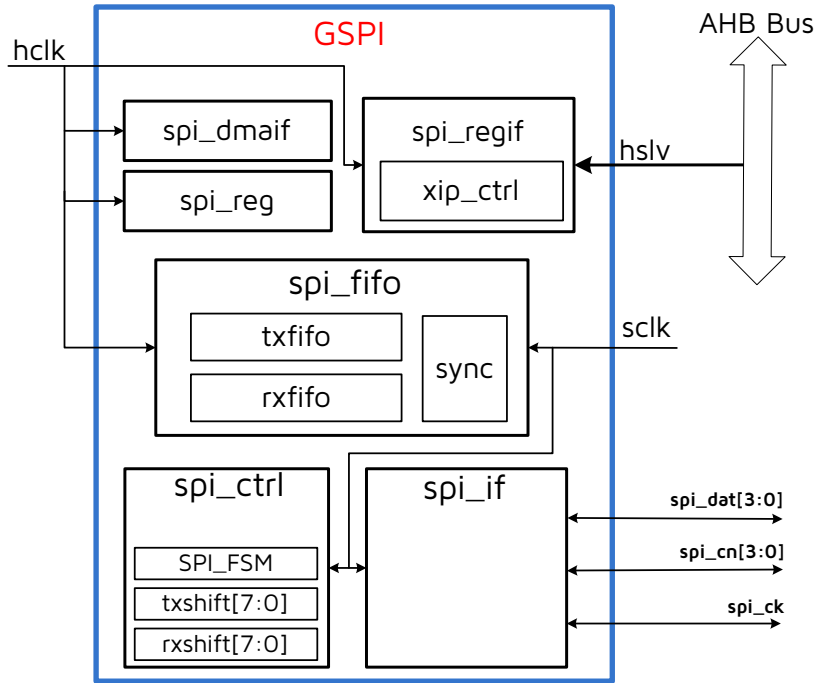
Figure 11-19 GSPI Diagram

11.8.2 GSPI Register Description

The GSPI related registers are listed as below. The base address of the following registers is 0x8BFFFF00.

Table 11-13 GSPI Related Registers

Offset	Type	Description	Default Value
0x00	RW	GSPI_WR_RD_DATA0 [7:0] wr_rd_data0, data[7:0] to transmit or received	0x00
0x01	RW	GSPI_WR_RD_DATA1 [7:0] wr_rd_data1, data[15:8] to transmit or received	0x00
0x02	RW	GSPI_WR_RD_DATA2 [7:0] wr_rd_data2, data[23:16] to transmit or received	0x00
0x03	RW	GSPI_WR_RD_DATA3 [7:0] wr_rd_data3, data[31:24] to transmit or received	0x00
0x04	RW	GSPI_CMD [7:0]: SPI Command	0x00

Offset	Type	Description	Default Value
0x05	RW	GSPI_CTRL0 [0] RXFIFOORIntEn, enable the SPI Receive FIFO Overrun interrupt, SLAVE ONLY [1] TXFIFOURIntEn, enable the SPI Transmit FIFO Underrun interrupt, SLAVE ONLY [2]: RXFIFOIntEn, enable the SPI Receive FIFO Threshold interrupt [3]: TXFIFOIntEn, enable the SPI Transmit FIFO Threshold interrupt [4]: EndIntEn, enable the End of SPI Transfer interrupt [6]: rx_dma_en, RX DMA enable [7]: tx_dma_en, TX DMA enable	0x00
0x07	RW	GSPI_TIMING [2:0] cs2sclk, the minimum time between the edge of SPI_CS and the edges of SPI_CLK. The actual duration is (SPI_CLK period*(cs2sclk+1)), MASTER ONLY [7:3] csht, the minimum time that SPI CS should stay HIGH. The actual duration is (SPI_CLK period*(csht+1)), MASTER ONLY	0x09
0x08	RW	GSPI_CTRL1 [1:0] data_lane, data lane, MASTER ONLY 0: single, 1: dual, 2: quad, 3: quad [3:2] addr_len, 2'b00:1bye 2'b01:2bytes 2'b10:3bytes 2'b11:4bytes, MASTER ONLY [4] addr_fmt, 0:single mode 1:the format of addr phase is the same as the data phase(Dual/Quad), MASTER ONLY [5] addr_en, 1:enabel addr phase, MASTER ONLY [6] cmd_fmt, 0: single mode 1: the format of the cmd phase is the same as the data phase(Dual/Quad), MASTER ONLY [7] cmd_en, the spi commnd phase enable, MASTER ONLY	0xa9

Offset	Type	Description	Default Value
0x09	RW	GSPI_CTRL2 [3:0] dummy_cnt, dummy number = {dummy_cnt_add, dummy_cnt} + 1 [7:4] transmode, the transfer mode the transfer sequence could be: 0x0: write and read at the same time (must enable CmdEn) 0x1: write only 0x2: read only (must enable CmdEn) 0x3: write, read 0x4: read, write 0x5: write, dummy, read 0x6: read, dummy, write (must enable CmdEn) 0x7: None Data (must enable CmdEn) 0x8: Dummy, write 0x9: Dummy, read 0xa~0xf: reserved	0x77
0x0c	RW	GSPI_ADDR0 [7:0] spi_addr0, spi address byte0, MASTER ONLY	0x0
0x0d	RW	GSPI_ADDR1 [7:0] spi_addr1, spi address byte1, MASTER ONLY	0x0
0x0e	RW	GSPI_ADDR2 [7:0] spi_addr2, spi address byte2, MASTER ONLY	0x0
0x0f	RW	GSPI_ADDR3 [7:0] spi_addr3, spi address byte3, MASTER ONLY	0x0
0x10	RW	GSPI_TX_CNT0 [7:0] tx_cnt0, transfer count for write data, byte0	0x00
0x11	RW	GSPI_TX_CNT1 [7:0] tx_cnt1, transfer count for write data, byte1	0x00
0x12	RW	GSPI_TX_CNT2 [7:0] tx_cnt2, transfer count for write data, byte2	0x00
0x14	RW	GSPI_RX_CNT0 [7:0] rx_cnt0, transfer count for read data, byte0	0x00

Offset	Type	Description	Default Value
0x15	RW	GSPI_RX_CNT1 [7:0] rx_cnt1, transfer count for read data, byte1	0x00
0x16	RW	GSPI_RX_CNT2 [7:0] rx_cnt2, transfer count for read data, byte2	0x00
0x18	RW	GSPI_CTRL3 [0] spi_lsb, transfer data with least significant bit first [1] spi_3line, MOSI is bi-directional signal in regular mode [3:2] spi_mode, spi_mode[0]:SPI_CLK Phase; spi_mode[1]:SPI_CLK Polarity [4] spi_master, SPI master mode selection [5] dmatx_sof_clrxfifo_en, auto clr txfifo when txdma start [6] dmarx_eof_clrrxfifo_en, auto clr rxfifo when rxdma end [7] auto_hready_en, auto control hready while access data register	0x90
0x19	RW	GSPI_TXFIFO_THRES [5:0] txfifo threshold	0x00
0x1a	RW	GSPI_RXFIFO_THRES [5:0] rxfifo threshold	0x00
0x1c	RW	GSPI_CTRL4 [0] xip_page_mode_en, xip page mode enable [1] xip_timeout_mode_en, 0:xip timeout disable 1:xip timeout enable [2] xip_stop, stop xip [3] xip_enable, enable xip [4] dummy_cnt_add	0x0a
0x1d	RW	GSPI_XIP_PAGE_SIZE [7:0] page_size, page boundary size = 2^page_size	0x00
0x1e	RW	GSPI_XIP_TIMEOUT_CNT [7:0] timeout_cnt, timeout time sel	0x20
0x22	RW	GSPI_XIP_ADDR_OFFSET [7:0] xip_addr_offset, address offset = xip_addr_offset << 24	0x00
0x24	R	GSPI_TXFIFO_STATUS [6:0] txfifo_entries [7] txfifo_full	0x0

Offset	Type	Description	Default Value
0x25	R	GSPI_RXFIFO_STATUS [6:0] rxfifo_entries [7] rxfifo_empty	0x0
0x28	RW/R	GSPI_STATUS [0] set_slave_ready(RW), set this bit to indicate that spi as salve is ready for data transaction [1] clr_slave_ready(RW), clear spi slave ready [2] spi_soft_reset(RW), spi soft reset, high valid [3] xip_reg_arb_err(R), xip mode and reg mode conflict flag [4] rxfifo_clr_level(RW), rxfifo is in clear status [5] txfifo_clr_level(RW), txfifo is in clear status [7] busy(R), SPI is transferring	0x0
0x2a	W1C	GSPI_INT_STATUS0 [0] rxf_overnun_int_stus, RX FIFO Overrun interrupt, SLAVE ONLY [1] txf_underrun_int_stus, TX FIFO Underrun interrpr,SLAVE ONLY [2] rxf_thres_int_stus, RX FIFO Threshold interrupt [3] txf_thres_int_stus, TX FIFO Threshold interrupt [4] trans_end_int_stus, End of SPI Transfer interrupt [5] slave_cmd_int_stus, Slave Command Interrupt, SLAVE ONLY	0x00
0x90	RW	GSPI_XIP_RD_FMT [0] xip0_rd_data_dual, spi dual I/O mode, MASTER ONLY [1] xip0_rd_data_quad, spi quad I/O mode, MASTER ONLY [3:2] xip0_rd_addr_len, 2'b00:1bye 2'b01:2bytes 2'b10:3bytes 2'b11:4bytes [4] xip0_rd_addr_fmt, 0:single mode 1:the format of addr phase is the same as the data phase (Dual/Quad) [5] xip0_rd_addr_en, 1:enable addr phase, MASTER ONLY [6] xip0_rd_cmd_fmt, 0: single mode 1: the format of the cmd phase is the same as the data phase (Dual/Quad), MASTER ONLY [7] xip0_rd_cmd_en, the spi command phase enable, MASTER ONLY	0xa9
0x91	RW	GSPI_XIP_RD_TRANSMODE [3:0] xip0_rd_dummy_cnt, dummy number = dummy_cnt + 1 [7:4] xip0_rd_transmode	0x97

Offset	Type	Description	Default Value
0x93	RW	GSPI_XIP_RD_CMD [7:0] xip0_rd_cmd, read command used for xip	0x3b
0x94	RW	GSPI_XIP_WR_FMT [0] xip0_wr_data_dual, spi dual I/O mode, MASTER ONLY [1] xip0_wr_data_quad, spi quad I/O mode, MASTER ONLY [3:2] xip0_wr_addr_len, 2'b00:1bye 2'b01:2bytes 2'b10:3bytes 2'b11:4bytes [4] xip0_wr_addr_fmt, 0:single mode 1:the format of addr phase is the same as the data phase (Dual/Quad), MASTER ONLY [5] xip0_wr_addr_en, 1:enabel addr phase, MASTER ONLY [6] xip0_wr_cmd_fmt, 0: single mode 1: the format of the cmd phase is the same as the data phase (Dual/Quad), MASTER ONLY [7] xip0_wr_cmd_en, the spi command phase enable, MASTER ONLY	0xa8
0x95	RW	GSPI_XIP_WR_TRANSMODE [7:4] xip0_wr_transmode	0x10
0x97	RW	GSPI_XIP_WR_CMD [7:0] xip0_wr_cmd, write command used for xip	0x02
0x98	RW	GSPI_XIP1_RD_FMT [0] xip1_rd_data_dual, spi dual I/O mode, MASTER ONLY [1] xip1_rd_data_quad, spi quad I/O mode, MASTER ONLY [3:2] xip1_rd_addr_len, 2'b00:1bye 2'b01:2bytes 2'b10:3bytes 2'b11:4bytes [4] xip1_rd_addr_fmt, 0:single mode 1:the format of addr phase is the same as the data phase (Dual/Quad) [5] xip1_rd_addr_en, 1:enable addr phase, MASTER ONLY [6] xip1_rd_cmd_fmt, 0: single mode 1: the format of the cmd phase is the same as the data phase (Dual/Quad), MASTER ONLY [7] xip1_rd_cmd_en, the spi command phase enable, MASTER ONLY	0xa9
0x99	RW	GSPI_XIP1_RD_TRANSMODE [3:0] xip1_rd_dummy_cnt, dummy number = dummy_cnt + 1 [7:4] xip1_rd_transmode	0x97

Offset	Type	Description	Default Value
0x9b	RW	GSPI_XIP1_RD_CMD [7:0] xip1_rd_cmd, read command used for xip	0x3b
0x9c	RW	GSPI_XIP1_WR_FMT [0] xip1_wr_data_dual, spi dual I/O mode, MASTER ONLY [1] xip1_wr_data_quad, spi quad I/O mode, MASTER ONLY [3:2] xip1_wr_addr_len, 2'b00:1bye 2'b01:2bytes 2'b10:3bytes 2'b11:4bytes [4] xip1_wr_addr_fmt, 0:single mode 1:the format of addr phase is the same as the data phase (Dual/Quad), MASTER ONLY [5] xip1_wr_addr_en, 1:enabel addr phase, MASTER ONLY [6] xip1_wr_cmd_fmt, 0: single mode 1: the format of the cmd phase is the same as the data phase (Dual/Quad), MASTER ONLY [7] xip1_wr_cmd_en, the spi command phase enable, MASTER ONLY	0xa8
0x9d	RW	GSPI_XIP1_WR_TRANSMODE [7:4] xip1_wr_transmode	0x10
0x9f	RW	GSPI_XIP1_WR_CMD [7:0] xip1_wr_cmd, write command used for xip	0x02
0xa0	RW	GSPI_XIP2_RD_FMT [0] xip2_rd_data_dual, spi dual I/O mode, MASTER ONLY [1] xip2_rd_data_quad, spi quad I/O mode, MASTER ONLY [3:2] xip2_rd_addr_len, 2'b00:1bye 2'b01:2bytes 2'b10:3bytes 2'b11:4bytes [4] xip2_rd_addr_fmt, 0:single mode 1:the format of addr phase is the same as the data phase (Dual/Quad) [5] xip2_rd_addr_en, 1:enable addr phase, MASTER ONLY [6] xip2_rd_cmd_fmt, 0: single mode 1: the format of the cmd phase is the same as the data phase (Dual/Quad), MASTER ONLY [7] xip2_rd_cmd_en, the spi command phase enable, MASTER ONLY	0xa9
0xa1	RW	GSPI_XIP2_RD_TRANSMODE [3:0] xip2_rd_dummy_cnt, dummy number = dummy_cnt + 1 [7:4] xip2_rd_transmode	0x97

Offset	Type	Description	Default Value
0xa3	RW	GSPI_XIP2_RD_CMD [7:0] xip2_rd_cmd, read command used for xip	0x3b
0xa4	RW	GSPI_XIP2_WR_FMT [0] xip2_wr_data_dual, spi dual I/O mode, MASTER ONLY [1] xip2_wr_data_quad, spi quad I/O mode, MASTER ONLY [3:2] xip2_wr_addr_len, 2'b00:1bye 2'b01:2bytes 2'b10:3bytes 2'b11:4bytes [4] xip2_wr_addr_fmt, 0:single mode 1:the format of addr phase is the same as the data phase (Dual/Quad), MASTER ONLY [5] xip2_wr_addr_en, 1:enabel addr phase, MASTER ONLY [6] xip2_wr_cmd_fmt, 0: single mode 1: the format of the cmd phase is the same as the data phase (Dual/Quad), MASTER ONLY [7] xip2_wr_cmd_en, the spi command phase enable, MASTER ONLY	0xa8
0xa5	RW	GSPI_XIP2_WR_TRANSMODE [7:4] xip2_wr_transmode	0x10
0xa7	RW	GSP2_XIP2_WR_CMD [7:0] xip2_wr_cmd, write command used for xip	0x02
0xa8	RW	GSPI_XIP3_RD_FMT [0] xip3_rd_data_dual, spi dual I/O mode, MASTER ONLY [1] xip3_rd_data_quad, spi quad I/O mode, MASTER ONLY [3:2] xip3_rd_addr_len, 2'b00:1bye 2'b01:2bytes 2'b10:3bytes 2'b11:4bytes [4] xip3_rd_addr_fmt, 0:single mode 1:the format of addr phase is the same as the data phase (Dual/Quad) [5] xip3_rd_addr_en, 1:enable addr phase, MASTER ONLY [6] xip3_rd_cmd_fmt, 0: single mode 1: the format of the cmd phase is the same as the data phase (Dual/Quad), MASTER ONLY [7] xip3_rd_cmd_en, the spi command phase enable, MASTER ONLY	0xa9
0xa9	RW	GSPI_XIP3_RD_TRANSMODE [3:0] xip3_rd_dummy_cnt, dummy number = dummy_cnt + 1 [7:4] xip3_rd_transmode	0x97

Offset	Type	Description	Default Value
0xab	RW	GSPI_XIP3_RD_CMD [7:0] xip3_rd_cmd, read command used for xip	0x3b
0xac	RW	GSPI_XIP3_WR_FMT [0] xip3_wr_data_dual, spi dual I/O mode, MASTER ONLY [1] xip3_wr_data_quad, spi quad I/O mode, MASTER ONLY [3:2] xip3_wr_addr_len, 2'b00:1bye 2'b01:2bytes 2'b10:3bytes 2'b11:4bytes [4] xip3_wr_addr_fmt, 0:single mode 1:the format of addr phase is the same as the data phase (Dual/Quad), MASTER ONLY [5] xip3_wr_addr_en, 1:enable addr phase, MASTER ONLY [6] xip3_wr_cmd_fmt, 0: single mode 1: the format of the cmd phase is the same as the data phase (Dual/Quad), MASTER ONLY [7] xip3_wr_cmd_en, the spi command phase enable, MASTER ONLY	0xa8
0xad	RW	GSPI_XIP3_WR_TRANSMODE [7:4] xip3_wr_transmode	0x10
0xaf	RW	GSP2_XIP3_WR_CMD [7:0] xip3_wr_cmd, write command used for xip	0x02
0xb0	RW	GSPI_XIP_SIZE_SET [1:0] xip_psrām0_end_addr, psrām0 space = {0, (xip_psrām0_end_addr+1) * 16m} [3:2] xip_psrām1_end_addr, psrām1 space = {(xip_psrām0_end_addr+1) * 16m, (xip_psrām1_end_addr+1) * 16m} [5:4] xip_psrām2_end_addr, psrām2 space = {(xip_psrām1_end_addr+1) * 16m, (xip_psrām2_end_addr+1) * 16m} [7:6] xip_psrām3_end_addr, psrām3 space = {(xip_psrām2_end_addr+1) * 16m, (xip_psrām3_end_addr+1) * 16m}	0x03

11.9 SPI Slave (SPI_SLV)

11.9.1 Diagram

SPI_SLV diagram is shown as below.

As shown in the diagram, SPI_SLAVE_Interface is used to analyze the protocol of the SPI interface, which is in spi_clk_i domain. SPI_SLAVE_Control is used to synchronize the data of spi_clk_i domain to sclk domain, and

parse out the address and data segment to AHB_MASTER module. The AHB_MASTER module synchronizes the data from the sclk domain to the ahb clk domain and sends the parsed address and data to form the AHB bus.

Figure 11-20 SPI_SLV Diagram

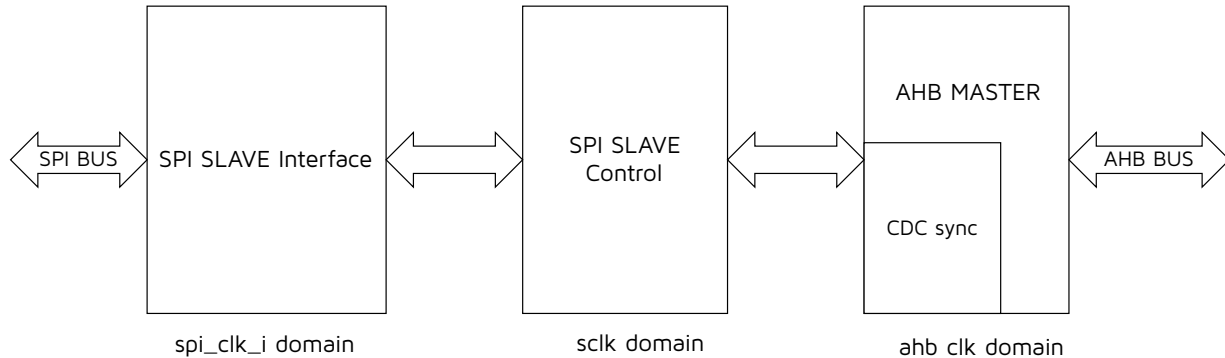

11.9.2 Features

The SoC embeds SPI_SLV interface for debugging, features of SPI_SLV are listed as following:

- Supports SPI Slave mode
- Supports Dual I/O SPI interface

11.9.3 Function Description

This module converts SPI timing to AHB Master request.

SPI Master data should be read and written in formats specified by SPI_SLV, shown as following:

Figure 11-21 SPI_SLV Write Format

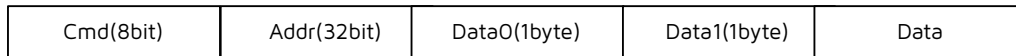
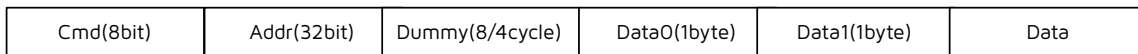

Figure 11-22 SPI_SLV Read Format



SPI_SLV determines the format and operation by parsing the commands, shown in the following table.

Table 11-14 SPI_SLV Commands

Name	Description	Default
Cmd[7:0]	Cmd[7]: value 0:spi write, value 1:spi read Cmd[6]: value 0:addr single i/o, value 1:addr dual i/o cmd[5]: value 0:data single i/o, value 1:data dual i/o cmd[4]: value 0:addr auto increase, value 1:disable addr auto increase cmd[3]:value0:read dummy 8 cycle, value1:read dummy 4 cycle cmd[2]: value1:ahb word transfer cmd[1]: value1: ahb half word transfer cmd[0]: reserved	8'b0000_0000: spi slave write with addr single i/o and data single i/o in the addr auto increasing mode.

Address auto increase does not support ahb word/half word transfer.

SPI_CLK_in supported frequencies:

When read_dummy is 8, SPI_CLK_in frequency $\leq (1/2) \times \text{hclk frequency}$.

When read_dummy is 4, SPI_CLK_in frequency $\leq (1/4) \times \text{hclk frequency}$.

11.10 UART

11.10.1 Introduction

The SoC embeds UART (Universal Asynchronous Receiver/Transmitter) to implement full-duplex transmission and reception via UART TX and RX interface.

The UART module also supports ISO7816 protocol to enable communication with ISO/IEC 7816 integrated circuit card, especially smart card. In this mode, half-duplex communication (transmission or reception) is supported via the shared 7816_TRX interface.

UART features include:

- Full-duplex operation
- Automatic flow control via RTS and CTS
- 8-bit UART mode, variable baud rate
- Optional even parity bit checking and generation
- Supports 1, 1.5 and 2 STOP bits
- Supports line breaks, parity errors, framing errors
- 8 bytes of transmit/receive FIFOs
- Supports ISO7816 protocol
- Supports DMA function (RX supports DMA Linked List Pointer)
- Up to 3 Mbps baud rate
- 2-channel UART (UART0, UART1)

11.10.2 Block Diagram

Figure 11-23 Block Diagram of UART

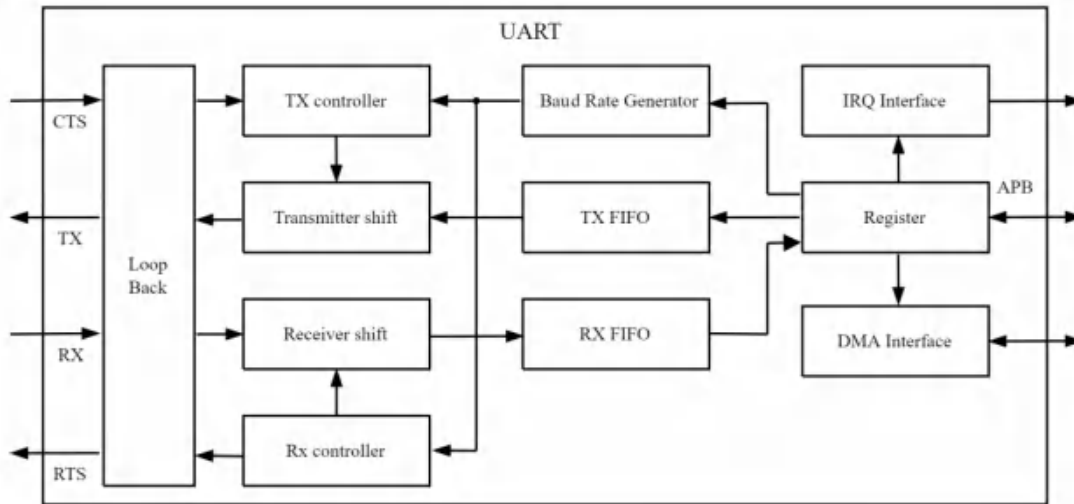

11.10.3 Function Description

11.10.3.1 Pin Configuration

The UART bidirectional communications require a minimum of two pins: Receive Data In (RX) and Transmit Data Out (TX):

- RX (Receive Data Input)

RX is the serial data input. Oversampling techniques are used for data recovery. In ISO7816 modes, this I/O is used to transmit and receive data.

- TX (Transmit Data Output)

When the transmitter is disabled, the output pin returns to its I/O port configuration. When the transmitter is enabled and no data needs to be transmitted, the TX pin is High.

The following pins are required in Hardware flow control mode:

- CTS (Clear To Send)

When driven low (optional), this signal blocks the data transmission at the end of the current transfer.

- RTS (Request To Send)

When it is low, this signal indicates that the UART is ready to receive data.

11.10.3.2 Transmitter

(1) NDMA Operation

The transmitter comprises a Transmitter FIFO (TX FIFO), a Transmitter Shift, and a Transmitter Controller (TX controller). The TX FIFO holds data to be transferred through the serial interface. The TX FIFO can store up to 8 characters depending on hardware configurations and programming settings. The Transmitter Shift reads a character from the TX FIFO for the next transmission. The Transmitter Shift functions as a parallel-to-serial data converter, converting the outgoing character to serial bit streams. For each character transmission, the TX Controller generates a START bit, an optional parity bit, and some number of STOP bits. The generation of

parity bit and STOP bit can be configured by the `uart_ctrl1` register. The TX FIFO is by default a 8-byte buffer called Transmitter Buffer Register.

(2) DMA Operation

When the TX FIFO under the threshold 4 characters, the UART controller will assert `dma_tx_req` to request a data transfer. The DMA controller should then transfer data to the TX FIFO followed by asserting `dma_tx_ack`. Next, the UART controller de-asserts `dma_tx_req` and the DMA controller de-asserts `dma_tx_ack`. The UART controller will assert `dma_tx_req` again unless the TX FIFO is full or the DMA transmission length is reached.

11.10.3.3 Receiver

(1) NDMA Operation

The receiver comprises a Receiver FIFO (RX FIFO), Receiver Shift, and a Receiver Controller (RX Controller). The RX Controller uses the oversampling clock generated by Baud Rate Generator to perform sampling at the center of each bit transmission. The received bits are shifted into the Receiver Shift for serial-to-parallel data conversion and the received character is stored into the RX FIFO. The RX FIFO is by default a 8byte buffer called the Receiver Buffer Register. The RX controller also detects some error conditions for each data transmission including parity error, framing error, or line break.

(2) DMA Operation

When the RX FIFO reaches the threshold 4 characters, the UART controller will assert `dma_rx_req` to request a data transfer. The DMA controller should then transfer data from the RX FIFO followed by asserting `dma_rx_ack`. Next, the UART controller de-asserts `dma_rx_req` and the DMA controller de-asserts `dma_rx_ack`. The UART controller will assert `dma_rx_req` again unless the RX FIFO is empty. DMA relies on `rxdone` to read parts of the data below 4 characters.

11.10.3.4 Baud Rate Generator

The Baud Rate Generator takes the UART clock as the source clock (`pclk`) and divides it with a divisor. The divisor consists of `uart_clk_div` and `bpwc` register. The `uart_clk_div` value is 15-bit in size and stored in two separate registers.

The formula for the divisor value is as follows:

$$\text{uart_sclk} = \text{pclk}/(\text{uart_clk_div}[14:0]+1)$$

$$\text{Baudrate} = \text{uart_sclk}/(\text{bpwc}+1), \text{bpwc} > 2$$

Suppose that:

- T1 is the period of one bit transmission as perceived by the Rx Controller.
- T2 is the period of one bit transmission of the transmitter.
- N is the bit number for one frame of data – the START bit, data bits, parity bit, and the STOP bit(s).

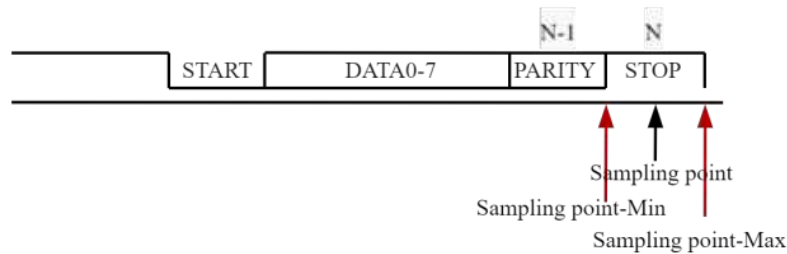
Figure 11-24 UART Protocol Formats and Sampling Point

Then, the clock period tolerance for is as follows:

$$(N-1) \times T_1 \leq (N-0.5) \times T_2$$

$$N \times T_1 \geq \left(N - \left(0.5 - \frac{1}{bpwc + 1} \right) \right) \times T_2$$

The calculation formula is obtained by conversion:

$$\left(1 - \frac{\left(0.5 - \frac{1}{bpwc + 1} \right)}{N} \right) \times T_2 \leq T_1 \leq \left(\frac{N-0.5}{N-1} \right) \times T_2$$

Since T is the inverse of the baud rate, the actual baud rate generated by this controller in relation to the actual baud rate of the transmitter (the tolerance factor) can be within the range below:

$$\left(1 - \frac{\left(0.5 - \frac{1}{bpwc + 1} \right)}{N} \right) \leq \frac{\text{Actual baud rate}}{\text{Actual transmission baud rate}} \leq \left(\frac{N-0.5}{N-1} \right)$$

If the character has one START bit, 8 data bits, one parity bit and one STOP bit, then N is 11 (1 + 8 + 1 + 1). The tolerance factor is from 0.9602 to 1.05. The table below shows clock tolerance factors as percentage of the actual Transmitter Baud Rates for typical values of N and bpwc register.

Table 11-15 Clock Variation Tolerance Factor

Typical Register Value	N = 10	N = 11	Conditions
bpwc = 15, uart_clk_div = 12	0.9563 - 1.056	0.9602 - 1.05	pclk: 24MHz
bpwc = 7, uart_clk_div = 25	0.9625 - 1.056	0.9659 - 1.05	baud rate: 115200bps

11.10.3.5 Loopback Mode

The UART provides a loopback mode for diagnostic testing without connecting an external device. When the loopback mode is enabled, the behavior of the controller is as follows:

- The output signals (TX, RTS) are disconnected from the TX/RX Controller and driven HIGH to avoid confusing the other end of the serial connection in case the connection exists.
- The input signals (RX, CTS) are disconnected from the TX/RX Controller and ignored.

- The TX Controller output values originally intended for the TX output signals are routed internally to replace the input signal of RX for the RX Controller, so every bit sent by the TX Controller is looped back and received by the RX controller. Note that CTS and RTS are similar.

11.10.3.6 Error Conditions

An ERROR event, in the form of a framing error, will be generated if a valid stop bit is not detected in a frame. Second ERROR event, in the form of a break condition, will be generated if the RX line is held active low for longer than the length of a data frame. Another ERROR event, Parity check bit error. The above ERROR event generates an rx_err interrupt.

11.10.3.7 Hardware Flow Control

It is possible to control the serial data flow between 2 devices by using the CTS input and the RTS output. The figure below shows how to connect 2 devices in this mode:

Figure 11-25 Hardware Flow Control between 2 UARTs

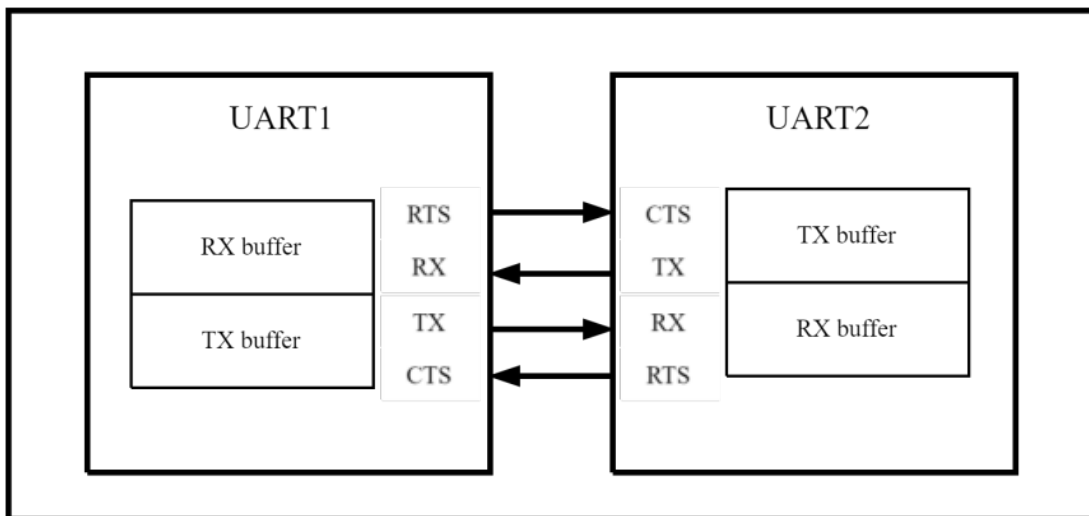

If RX buffer of the UART is close to threshold, the UART will send a signal (configurable high or low level) via pin RTS to inform other device that it should stop sending data. Similarly, if the UART receives a signal from pin CTS, it indicates that RX buffer of other device is close to full and the UART should stop sending data.

The threshold can be configured using the register `uart_ctrl2[3:0]`.

If the flow control is not enabled, the interface will behave as if the CTS and RTS lines are kept active all the time.

11.10.3.8 Receiver Timeout

Receiver timeout is used to handle when the data received per frame does not reach the threshold. Because data read from the Receiver Buffer Register is a multiple of 4 at a time, The rxdone interrupt is required to process the remaining data below the threshold.

NOTE:

- The DMA Operation threshold is fixed at 4.
- The NDMA Operation threshold can be configured through the register `uart_ctrl3[3:0]`.

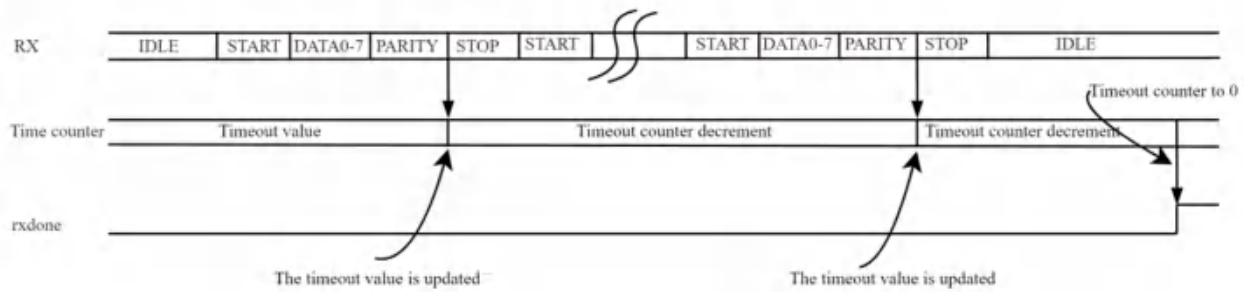
Figure 11-26 Timeout Flag Used for Data Transmission

The Time out counter inside the UART is updated at the STOP bit, and when receiving data stops, the Timeout counter decreases to 0 and generates a rxdone interrupt.

11.10.4 Register Description

UART related registers are listed in tables below.

For UART0 related register, the base address is 0x8140080, for UART1 related register, the base address is 0x81400c0.

Table 11-16 UART Related Registers

Offset	Name	Type	Description	Default Value
0x00	uart_data_buf0	Volatile	Bit7-0 of Transmitter/Receiver Buffer Register (TX/RX FIFO)	0x00
0x01	uart_data_buf1	Volatile	Bit15-8 of Transmitter/Receiver Buffer Register (TX/RX FIFO)	0x00
0x02	uart_data_buf2	Volatile	Bit23-16 of Transmitter/Receiver Buffer Register (TX/RX FIFO)	0x00
0x03	uart_data_buf3	Volatile	Bit31-24 of Transmitter/Receiver Buffer Register (TX/RX FIFO)	0x00
0x04	uart_clk_div_l	RW	[7:0]: Least significant byte of the uart_clk_div register	0xff
0x05	uart_clk_div_h	RW	[6:0]: Most significant byte of the uart_clk_div register $uart_sclk = pclk / (uart_clk_div[14:0] + 1)$ [7]: enable clock divider 1: enable 0: disable	0x0f

Offset	Name	Type	Description	Default Value
0x06	uart_ctrl0	RW	<p>[3:0] bpwc, bit width should be larger than 2 Baudrate = $\text{uart_sclk}/(\text{bpwc}+1)$</p> <p>[4] Auto clear function enable of DMA and NDMA mode; 1:enable,0:disable</p> <p>[5] rxdone (timeout) function enable in NDMA mode; 1:enable,0:disable; The DMA mode must disabled.</p> <p>[6] RTS controls timeout stop enabled; 1:enable,0:disable</p> <p>[7] 7816 enable; 1:enable,0:disable</p>	0x7f
0x07	uart_ctrl1	RW	<p>[0]: Polarity of CTS 0: Active low (0 - End of transmission) 1: Active high (1 - End of transmission)</p> <p>[1]: CTS enable, 1: enable, 0: disable</p> <p>[2]:Parity enable When this bit is set, a parity bit is generated in transmitted data before the first STOP bit and the parity bit would be checked for the received data.</p> <p>[3]: Even parity select, 1: old parity; 0: even parity (an even number of logic-1 is in the data and parity bits).</p> <p>[5:4]: stop bit, 00: STOP bit is 1 bit; 01: STOP bit is 1.5 bits; 1x: STOP bit is 2 bits</p> <p>[6]: TX and RX polarity selection, 0: Non-inverting; 1: Inverting</p> <p>[7]: Enable loopback mode, 1: enable; 0: disable</p>	0x0e
0x08	uart_ctrl2	RW	<p>[3:0]: RTS trig level. Trigger RTS when the RX FIFO reaches the threshold.</p> <p>[4]: Polarity of RTS 0: Active high (0-ready for receiving) 1: Active low (1-ready for receiving)</p> <p>[5]: RTS manual value</p> <p>[6]: RST manual enable</p> <p>[7]: RTS enable, 1: enable; 0: disable</p>	0xa5

Offset	Name	Type	Description	Default Value
0x09	uart_ctrl3	RW	[3:0] rx_irq_trig level. Trigger rx_buf_irq interrupt when the RX FIFO reaches the threshold. [7:4] tx_irq_trig level. Trigger tx_buf_irq interrupt when the TX FIFO under the threshold.	0x44
0x0a	r_rxtimeout_l	RW	[7:0]: Least significant byte of the r_rxtimeout_o register: The setting is transfer one bytes need cycles base on uart_clk. For example, if transfer one byte (1start bit+8bits data+1 priority bit+2stop bits) total 12 bits, this register setting should be (bpwc+1)*12.	0xc0
0x0b	r_rxtimeout_h	RW	[1:0]: Most significant byte of the r_rxtimeout register 2'b00: rx timeout time is r_rxtimeout[7:0] 2'b01: rx timeout time is r_rxtimeout[7:0]*2 2'b10: rx timeout time is r_rxtimeout[7:0]*3 3'b11: rx timeout time is r_rxtimeout[7:0]*4 r_rxtimeout is for rx dma to decide the end of each transaction. Supposed the interval between each byte in one transaction is very short. [2]: Enable rx_buf_irq interrupt [3]: Enable tx_buf_irq interrupt [4]: Enable rxdone_irq interrupt [5]: Enable txdone interrupt [6]: Enable rx_err interrupt [7]: Reserved	0x01
0x0c	buf_cnt	R	[3:0]: rx_buf_cnt This register is increased when there are incoming received data in the Receiver Buffer Register. When there is read data in the Receiver Buffer Register, this register is decremented. [7:4]: tx_buf_cnt This register is decremented when there are outgoing sent data in the Transmitter Buffer Register. When there is write data in the Transmitter Buffer Register, this register is increased.	0x00

Offset	Name	Type	Description	Default Value
0x0d	uart_sts	R	<p>[2:0]: rcnt. When there is read data in the Receiver Buffer Register, this register is decremented.</p> <p>[3]: irq. Total interruption of UART.</p> <p>[6:4]: wbcnt. When there is write data in the Transmitter Buffer Register, this register is increased.</p> <p>[7]: rxdone. Similar to the rxdone irq interrupt, but rxdone is automatically cleared by the UART.</p>	0x00

Offset	Name	Type	Description	Default Value
0x0e	irq_sts	Volatile	<p>[1:0]: rx_rem_cnt_d. This register is increased when there are incoming received data in the Receiver Buffer Register. Gets incoming received data in the Receiver Buffer Register less than 1word.</p> <p>[2]: rx_buf_irq. When the RX FIFO reaches the threshold set by the rx_irq_trig Register, the UART controller will assert rx_buf_irq interrupt. W: write 1 to clear RX FIFO pointer, rx err, and so on. Note: When RX FIFO is below the threshold set by the rx_irq_trig Register, the rx_buf_irq interrupt clears automatically.</p> <p>[3]: tx_buf_irq When the TX FIFO under the threshold set by the tx_irq_trig register, the UART controller will assert tx_buf_irq interrupt. W: write 1 to clear TX FIFO pointer, and so on. Note: When TX FIFO is greater than the threshold set by the tx_irq_trig register, the tx_buf_irq interrupt clears automatically.</p> <p>[4]: rxdone_irq When the receiver ends (the timeout counter decays to 0), the UART controller will assert rxdone_irq interrupt. W: write 1 to clear rxdone_irq</p> <p>[5]: txdone. When the transmitter ends, the UART controller will assert txdone interrupt. W: write 1 to clear txdone</p> <p>[6]: rx_err. The error status is asserted when the following error events: parity errors framing errors, line breaks</p> <p>[7]: timeout The flag bit that the timeout counter decays to 0.</p>	0x00

Offset	Name	Type	Description	Default Value
0x0f	state_sts	R	[2:0]: tx state machine 0-idle 1-Start 2-Byte 3-Parity 4-Stop 5-pop byte [3]: reserved [7:4]: rx state machine 0 -idle 1-Start 2-Bit 3-Parity 4-Stop 5-check parity 6-Prepare 7-end bit 8-lc parity 9-Wait 10-push	0x00
0x10	UART_CTRL4	RW	[[0]: rxdone_rts_en 1: rxdone enables the RTS 0: rxdone disables the RTS [1]: Reserved	0x01

11.11 USB

The SoC has a full-speed (12 Mbps) USB interface for communicating with other compatible digital devices. The USB interface acts as a USB peripheral, responding to requests from a master host controller. The chip contains internal 1.5kOhm pull up resistor for the DP pin.

Telink USB interface supports the Universal Serial Bus Specification, Revision v2.0 (USB v2.0 Specification).

The chip supports 9 endpoints, including control endpoint 0 and 8 configurable data endpoints. Endpoint 1, 2, 3, 4, 7 and 8 can be configured as input endpoint, while endpoint 5 and 6 can be configured as output endpoint. In audio class application, only endpoint 6 supports iso out mode, while endpoint 7 supports iso in

mode. In other applications, each endpoint can be configured as bulk, interrupt and iso mode. For control endpoint 0, the chip's hardware vendor command is configurable.

Optional suspend mode:

- Selectable as USB suspend mode or chip suspend mode, support remote wakeup.
- Current draw in suspend mode complied with USB v2.0 Specification.
- USB pins (DM, DP) can be used as GPIO function in suspend mode.
- Resume and detach detect: Recognize USB device by detecting the voltage on the DP pin with configurable 1.5K pull-up resistor.
- USB pins configurable as wakeup GPIOs.

The USB interface belongs to an independent power domain, and it can be configured to power down independently.

NOTE: Since 1.8V IO voltage does not comply with USB electrical layer regulations, the IO voltage of GPIO cannot be configured to 1.8V when using USB.

The USB related registers are listed in table below, the base address is 0x80100800.

Table 11-17 USB Related Registers

Offset	Type	Description	Default Value
0x00	Volatile	EDPOPTR [3:0]: reg_ptr, Endpoint 0 buffer point	0x00
0x01	Volatile	EDPODAT [7:0]: buff, Endpoint 0 buffer data access address	0x00
0x02	Volatile	EDPOCT [0]: ack_data, Ack data [1]: stall_data, Stall data [2]: ack_status, Ack status [3]: stall_status, Stall status [7:4]: udc_cnt, number of data transferred	0x00
0x03	R	EDPOST [0]: irq_reset, W: Clear usb reset edge interrupted [1]: irq_250us_sof, W: Clear usb 250us or sof edge interrupted [2]: suspend_i, USB suspend status read only: suspend [4]: irq_setup, setup interrupt flag, W: Clear irq_setup interrupted [5]: irq_data, data interrupt flag, W: Clear irq_data interrupted [6]: irq_status, status interrupt flag, W: Clear irq_status interrupted [7]: irq_setinf, set interface interrupt flag, W: Clear irq_setinf interrupted	0x00

Offset	Type	Description	Default Value
0x04	RW	EDPOMODE [0]: r_en_sadr, enable auto decoding set_address command [1]: r_en_cfg, enable auto decoding set_config command [2]: r_en_inf, enable auto decoding set_interface command [3]: r_en_sta, enable auto decoding get_status command [4]: r_en_frm, enable auto decoding sync_frame command [5]: r_en_desc, enable auto decoding get_descriptor command [6]: r_en_fea, enable auto decoding set_feature command [7]: r_en_hw, enable auto decoding standard command	0xff
0x05	RW	USBCT [0]: r_clk_sel_0, use auto calibrate clock if 1, use system clock if 0 [1]: low_speed, low speed mode if 1; full speed mode if 0 [2]: r_clk_sel_2, low jitter mode if 1 [3]: test_mode, usb test mode [7:4]: r_clk_sel_o, 2 for select 48M RC clock; 1 for 400M RC	0x01
0x06	R	CALCYCL [7:0]: r_clk_div_il, r_clk_div_i[7:0]	0x00
0x07	R	CALCYCH [2:0]: r_clk_div_ih, r_clk_div_i[10:8]	0x00
0x0a	RW	MDEV [0]: r_mdev, self power, 1: self power, 0: bus power [2]: wakeup_feature_o, wakeup feature read only [3]: r_vend, r_vnd[0] vendor cmd offset (byte1[7] == r_vnd[0] means vendor cmd) [4]: r_vend_disable, 1 for disable vendor cmd [6:5]: mode_sel, 2'b0 --byte; 2'b1--halfword; 2'b2---word	0x18
0x0b	R	EDPOSIE [6:0]: sie_adr_i, usb_address [7]: r_config, config_now	0x00
0x0c	RW	SUSPENDCYC [4:0]: r_suspend_cnt, suspend_cnt [5]: r_edp0_stall, Avoid bugs with 8 multiples of in transfers [7:6]: hold0	0x18

Offset	Type	Description	Default Value
0x0d	R	INFALT [7:0]: r_infalt, Interface and alternate setting number in last SET_INTERFACE command	0x00
0x0e	RW	EDPS_EN [7:0]: edps_en	0xff
0x0f	RW	IRQ_MASK [2:0]: r_mask, mask[0]: irq_reset; mask[1]: irq_250us; mask[2]: irq_suspend; [4:3]: r_lvl, lvl[0]: 0-->irq_reset_edge; 1-->usb_reset_i; lvl[1]: 0-->irq_250us_edge; 1-->usb_250us_i; [5]: r_250us_sof_sel, 1'b0 sel 250us; 1'b1 sel sof [7:6]: hold1	0x04
0x10	Volatile	EDPSPTR [7:0]: rd_ptrl	0x00
0x11	Volatile	EDPS1PTR [7:0]: rd_ptrl	0x00
0x12	Volatile	EDPS2PTR [7:0]: rd_ptrl	0x00
0x13	Volatile	EDPS3PTR [7:0]: rd_ptrl	0x00
0x14	Volatile	EDPS4PTR [7:0]: rd_ptrl	0x00
0x15	Volatile	EDPS5PTR [7:0]: rd_ptrl	0x00
0x16	Volatile	EDPS6PTR [7:0]: rd_ptrl	0x00
0x17	Volatile	EDPS7PTR [7:0]: rd_ptrl	0x60
0x18	Volatile	EDPSPTRH [1:0]: rd_ptrh	0x00
0x19	Volatile	EDPS1PTRH [1:0]: rd_ptrh	0x00

Offset	Type	Description	Default Value
0x1a	Volatile	EDPS2PTRH [1:0]: rd_ptrh	0x00
0x1b	Volatile	EDPS3PTRH [1:0]: rd_ptrh	0x00
0x1c	Volatile	EDPS4PTRH [1:0]: rd_ptrh	0x00
0x1d	Volatile	EDPS5PTRH [1:0]: rd_ptrh	0x00
0x1e	Volatile	EDPS6PTRH [1:0]: rd_ptrh	0x00
0x1f	Volatile	EDPS7PTRH [1:0]: rd_ptrh	0x00
0x20	Volatile	EDPSDATA [7:0]: sr_q	0x00
0x21	Volatile	EDPS1DATA [7:0]: sr_q	0x00
0x22	Volatile	EDPS2DATA [7:0]: sr_q	0x00
0x23	Volatile	EDPS3DATA [7:0]: sr_q	0x00
0x24	Volatile	EDPS4DATA [7:0]: sr_q	0x00
0x25	Volatile	EDPS5DATA [7:0]: sr_q	0x00
0x26	Volatile	EDPS6DATA [7:0]: sr_q	0x00
0x27	Volatile	EDPS7DATA [7:0]: sr_q	0x00

Offset	Type	Description	Default Value
0x28	Volatile	EDP5SCT [0]: rd_ack, ACK [1]: rd_stall, Stall [2]: set_data0, Set Data0 [3]: set_data1, Set Data1 [7]: edp8_dma_eof, Launch EOF for FIFO mode (W) (no support)	0x00
0x29	Volatile	EDP1SCT [0]: rd_ack, ACK [1]: rd_stall, Stall [2]: set_data0, Set Data0 [3]: set_data1, Set Data1	0x00
0x2a	Volatile	EDP2SCT [0]: rd_ack, ACK [1]: rd_stall, Stall [2]: set_data0, Set Data0 [3]: set_data1, Set Data1	0x00
0x2b	Volatile	EDP3SCT [0]: rd_ack, ACK [1]: rd_stall, Stall [2]: set_data0, Set Data0 [3]: set_data1, Set Data1	0x00
0x2c	Volatile	EDP4SCT [0]: rd_ack, ACK [1]: rd_stall, Stall [2]: set_data0, Set Data0 [3]: set_data1, Set Data1	0x00
0x2d	Volatile	EDP5SCT [0]: rd_ack, ACK [1]: rd_stall, Stall [2]: set_data0, Set Data0 [3]: set_data1, Set Data1	0x00

Offset	Type	Description	Default Value
0x2e	Volatile	EDP6SCT [0]: rd_ack, ACK [1]: rd_stall, Stall [2]: set_data0, Set Data0 [3]: set_data1, Set Data1 [6]: rd_mono_aout, MONO mode [7]: rd_en_aout, Audio ISO out enable	-
0x2f	Volatile	EDP7SCT [0]: rd_ack, ACK [1]: rd_stall, Stall [2]: set_data0, Set Data0 [3]: set_data1, Set Data1 [6]: rd_mono_aout, MONO mode [7]: rd_en_ain, Audio ISO in enable	-
0x30	RW	EDPSADR, Endpoint 8(0) buffer address low	0x80
0x31	RW	EDPS1ADR, Endpoint 1 buffer address low	0x00
0x32	RW	EDPS2ADR, Endpoint 2 buffer address low	0x08
0x33	RW	EDPS3ADR, Endpoint 3 buffer address low	0x10
0x34	RW	EDPS4ADR, Endpoint 4 buffer address low	0x40
0x35	RW	EDPS5ADR, Endpoint 5 buffer address low	0xc0
0x36	RW	EDPS6ADR, Endpoint 6 buffer address low	0x20
0x37	RW	EDPS7ADR, Endpoint 7 buffer address low	0x30
0x38	RW	EDPSADRH, [1:0] Endpoint 8(0) buffer address high	0x00
0x39	RW	EDPS1ADRH, [1:0] Endpoint 1 buffer address high	0x00
0x3a	RW	EDPS2ADRH, [1:0] Endpoint 2 buffer address high	0x00
0x3b	RW	EDPS3ADRH, [1:0] Endpoint 3 buffer address high	0x00
0x3c	RW	EDPS4ADRH, [1:0] Endpoint 4 buffer address high	0x00
0x3d	RW	EDPS5ADRH, [1:0] Endpoint 5 buffer address high	0x00
0x3e	RW	EDPS6ADRH, [1:0] Endpoint 6 buffer address high	0x00
0x3f	RW	EDPS7ADRH, [1:0] Endpoint 7 buffer address high	0x00

Offset	Type	Description	Default Value
0x40	RW	USBSO, Enable endpoint ISO mode	0xc0
0x41	RW	USBIRQ [7:0]: r_irq, Endpoint data transfer interrupt	0x00
0x42	RW	USBMASK, Endpoint interrupt mask	0xff
0x43	RW	USBMAX0, Maximum endpoint 8 transfer number: max_size = {USBMAX0[7:0],5'h0}	0x10
0x44	RW	USBMIN0, Minimum threshold to ACK endpoint 8 transfer (the buffer must have USBMIN8 data to ack to IN YOKEN)	0x40
0x45	RW	USBFIFO [0]: r_fifo0, Endpoint 0 FIFO mode: the pointer of endpoint8 auto as a circuit buffer [1]: full0, Full flag [2]: r_mode00 [3]: edp8_eof [6:4]: edp8_dma_eof [7]: r_mode05	-
0x46	RW	USBMAX [6:0]: max_in, Max data in for endpoint buffer (except 7): Max_data_size =USBMAX*8	0x08
0x47	Volatile	USBTICK [7:0] r_tick, Just a tick that increase on posedge of the sclk_usb	0x00
0x48	RW	USBRAM [0]: sr_cen, CEN in power down mode [1]: sr_clk, CLK in power down mode [2]: r_ram2, Reserved [3]: wen_i, WEN in power down mode [4]: r_ram4, CEN in function mode	0x18
0x49	RW	USBMIN1 [1:0] usb_blk1, Minimum threshold to ACK endpoint 8 transfer [2] hold2	0x00

12 PWM

The SoC supports 6-channel PWM (Pulse-Width-Modulation) output. Each PWM#n (n=0-5) has its corresponding inverted output at PWM#n_N pin.

12.1 Enable PWM

Register PWM_EN[5:1] and PWM_ENO[0] serves to enable PWM5~PWM0 respectively via writing "1" for the corresponding bits.

12.2 Set PWM Clock

PWM clock derives from system clock. Register PWM_CLKDIV serves to set the frequency dividing factor for PWM clock. Formula below applies:

$$F_{PWM} = F_{System_clock} / (PWM_CLKDIV + 1)$$

12.3 PWM Waveform, Polarity and Output Inversion

Each PWM channel has independent counter and 2 status including "Count" and "Remaining". Count and Remaining status form a signal frame.

12.3.1 Waveform of Signal Frame

When PWM#n is enabled, first PWM#n enters Count status and outputs High level signal by default. When PWM#n counter reaches cycles set in register PWM_TCMP#n / PWM_TCMP_FSK_L/PWM_TCMP_FSK_H PWM#n enters Remaining status and outputs Low level till PWM#n cycle time configured in register PWM_TMAX#n / PWM_TMAX_FSK_L/ PWM_TMAX_FSK_H expires.

An interruption will be generated at the end of each signal frame if enabled via register PWM_MASK.

Signal frame is shown as following:

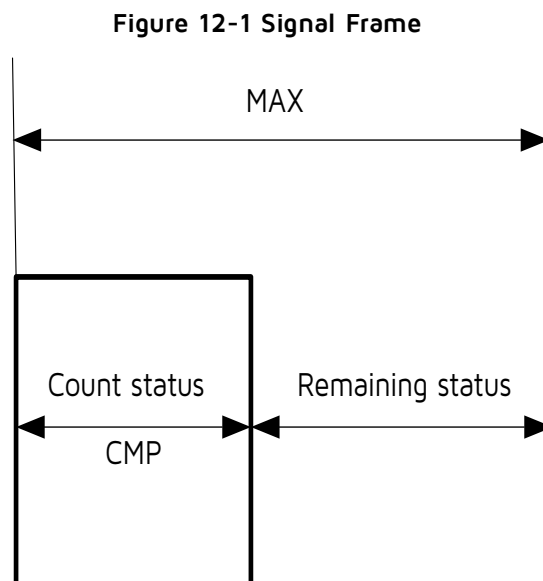

12.3.2 Invert PWM Output

PWM#n and PWM#n_N output could be inverted independently via register PWM_CCO and PWM_CC1. When the inversion bit is enabled, waveform of the corresponding PWM channel will be inverted completely.

12.3.3 Polarity for Signal Frame

By default, PWM#n outputs High level at Count status and Low level at Remaining status. When the corresponding polarity bit is enabled via register PWM_CC2[5:0], PWM#n will output Low level at Count status and High level at Remaining status.

PWM output waveform is shown as below.

Figure 12-2 PWM Output Waveform Chart

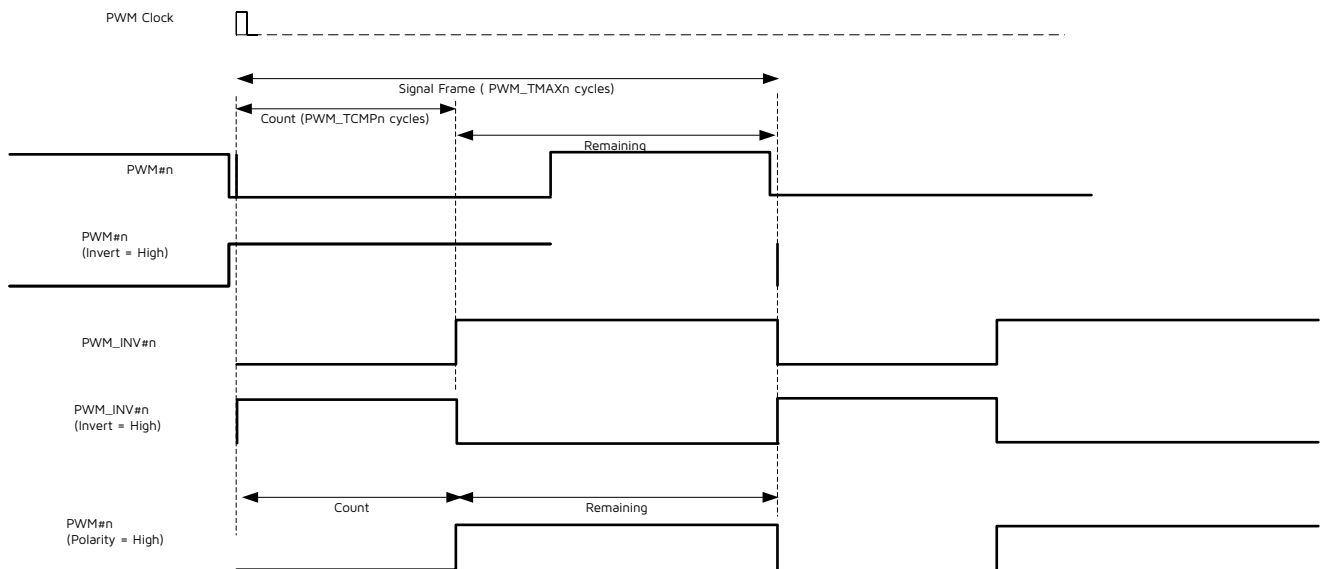

12.4 PWM Mode

12.4.1 Select PWM Modes

PWMO supports five modes, including Continuous mode (normal mode, default), Counting mode, IR mode, IR FIFO mode, IR DMA FIFO mode.

PWM1-PWM5 only support Continuous mode.

Register PWM_MODE serves to select PWMO mode.

12.4.2 Continuous Mode

PWMO-PWM5 all support Continuous mode. In this mode, PWM#n continuously sends out signal frames. PWM#n should be disabled via PWM_EN/PWN_ENO to stop it; when stopped, the PWM output will turn low immediately.

During Continuous mode, waveform could be changed freely via PWM_TCMP#n and PWM_TMAX#n. New configuration for PWM_TCMP#n and PWM_TMAX#n will take effect in the next signal frame.

After each signal frame is finished, corresponding PWM cycle done interrupt flag bit (PWM_INT[2:7]) will be automatically set to 1'b1. If the interrupt is enabled by setting PWM_MASK0[2:7] as 1'b1, a frame interruption will be generated. User needs to write 1'b1 to the flag bit to manually clear it.

Figure 12-3 Continuous Mode

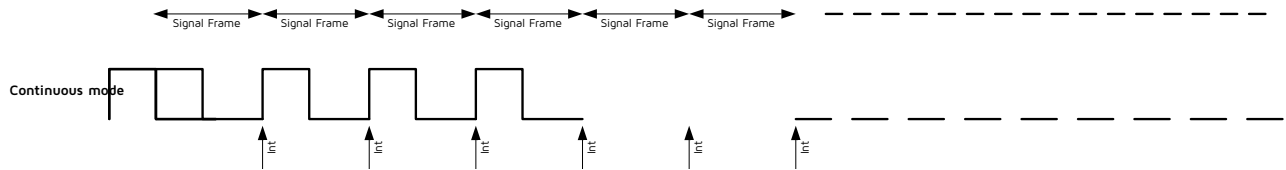

12.4.3 Counting Mode

Only PWM0 supports Counting mode. PWM_MODE [2:0] should be set as 4b'0001 to select PWM0 counting mode.

In this mode, PWM0 sends out specified number of signal frames which is defined as a pulse group. The number is configured via register PWM_PNUM.

After each signal frame is finished, PWM0 cycle done interrupt flag bit (PWM_INT[2]) will be automatically set to 1'b1. If the interrupt is enabled by setting PWM_MASK0 [2] as 1'b1, a frame interruption will be generated. User needs to write 1'b1 to the flag bit to manually clear it.

After a pulse group is finished, PWM0 will be disabled automatically, and PWM0 pnum interrupt flag bit (PWM_INT [0]) will be automatically set to 1'b1. If the interrupt is enabled by setting PWM_MASK0 as 1'b1, a Pnum interruption will be generated. User needs to write 1'b1 to the flag bit to manually clear it.

Counting mode also serves to stop IR mode gracefully.

Figure 12-4 Counting Mode (n=0)

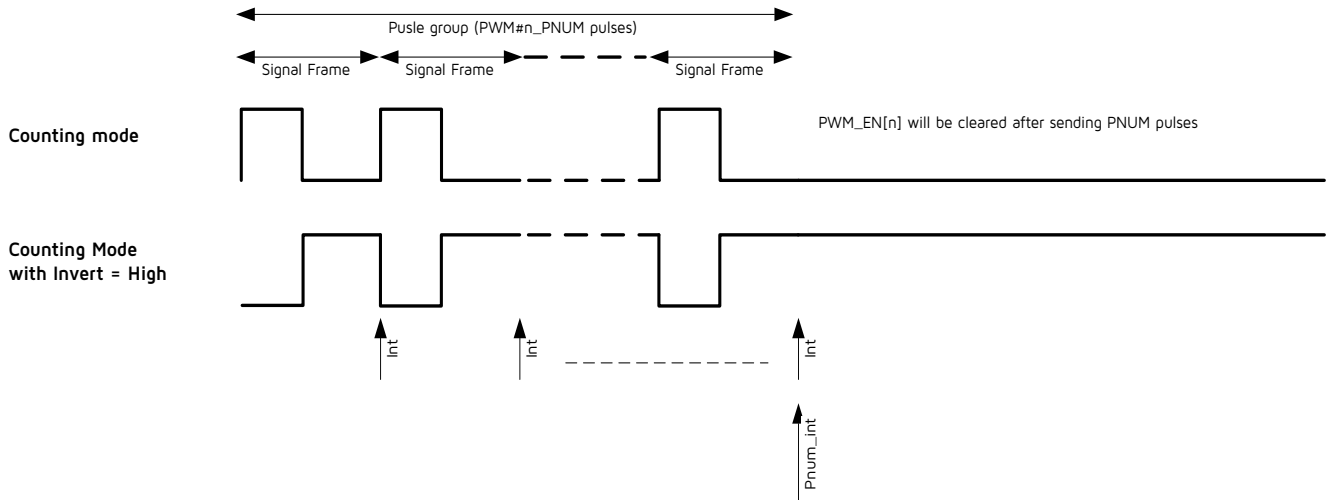

12.4.4 IR Mode

Only PWM0 supports IR mode. PWM_MODE[2:0] should be set as 4b'0011 to select PWM0 IR mode.

In this mode, specified number of frames is defined as one pulse group. In contrast to Counting mode where PWM0 stops after first pulse group is finished, PWM0 will constantly send pulse groups in IR mode.

During IR mode, PWM0 output waveform could also be changed freely via PWM_TCMPO, PWM_TMAXO and PWM_PNUMO. New configuration for PWM_TCMPO, PWM_TMAXO and PWM_PNUMO will take effect in the next pulse group.

To stop IR mode and complete current pulse group, user can switch PWM0 from IR mode to Counting mode so that PWM0 will stop after current pulse group is finished. If PWM0 is disabled directly via PWM_ENO[0], PWM0 output will turn Low immediately despite of current pulse group.

After each signal frame/pulse group is finished, PWM0 cycle done interrupt flag bit (PWM_INT[2])/PWM0 pnum interrupt flag bit (PWM_INT[0]) will be automatically set to 1'b1. A frame interruption/Pnum interruption will be generated.

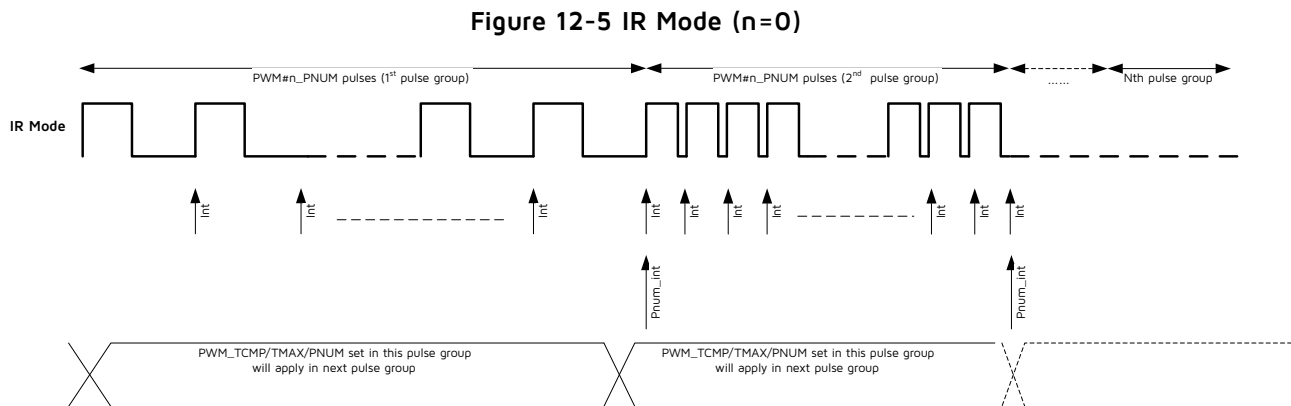

12.4.5 IR FIFO Mode

IR FIFO mode is designed to allow IR transmission of long code patterns without the continued intervention of MCU, and it is designed as a selectable working mode on PWM0. The IR carrier frequency is divided down from the system clock and can be configured as any normal IR frequencies, e.g. 36 kHz, 38 kHz, 40 kHz, or 56 kHz.

Only PWM0 supports IR FIFO mode. PWM_MODE[2:0] should be set as 4b'0111 to select PWM0 IR FIFO mode.

An element ("FIFO CFG Data") is defined as basic unit of IR waveform, and written into FIFO. This element consists of 16 bits, including:

- bit[13:0] defines PWM pulse number of current group.
- bit[14] determines duty cycle and period for current PWM pulse group.
- 0: use configuration of TCMPO and TMAXO;
- 1: use configuration of PWM_TCMPO_FSK_L/PWM_TCMPO_FSK_H and PWM_TMAXO_FSK_L/PWM_TMAXO_FSK_H.
- bit[15] determines whether current PWM pulse group is used as carrier, i.e. whether PWM will output pulse (1) or low level (0).

User should use PWM_RDAT_LO, PWM_RDAT_HO, PWM_RDAT_L1, PWM_RDAT_H1 in 0x7c8-0x7cb to write the 16-bit "FIFO CFG Data" into FIFO by byte or half word or word.

- To write by byte, user should successively write 0x7c8, 0x7c9, 0x7ca and 0x7cb.
- To write by half word, user should successively write 0x7c8 and 0x7ca.
- To write by word, user should write 0x7c8.

FIFO depth is 8 bytes. User can read the register FIFO_SR in 0x7cd to view FIFO empty/full status and check FIFO data number.

Figure 12-6 IR Format Examples

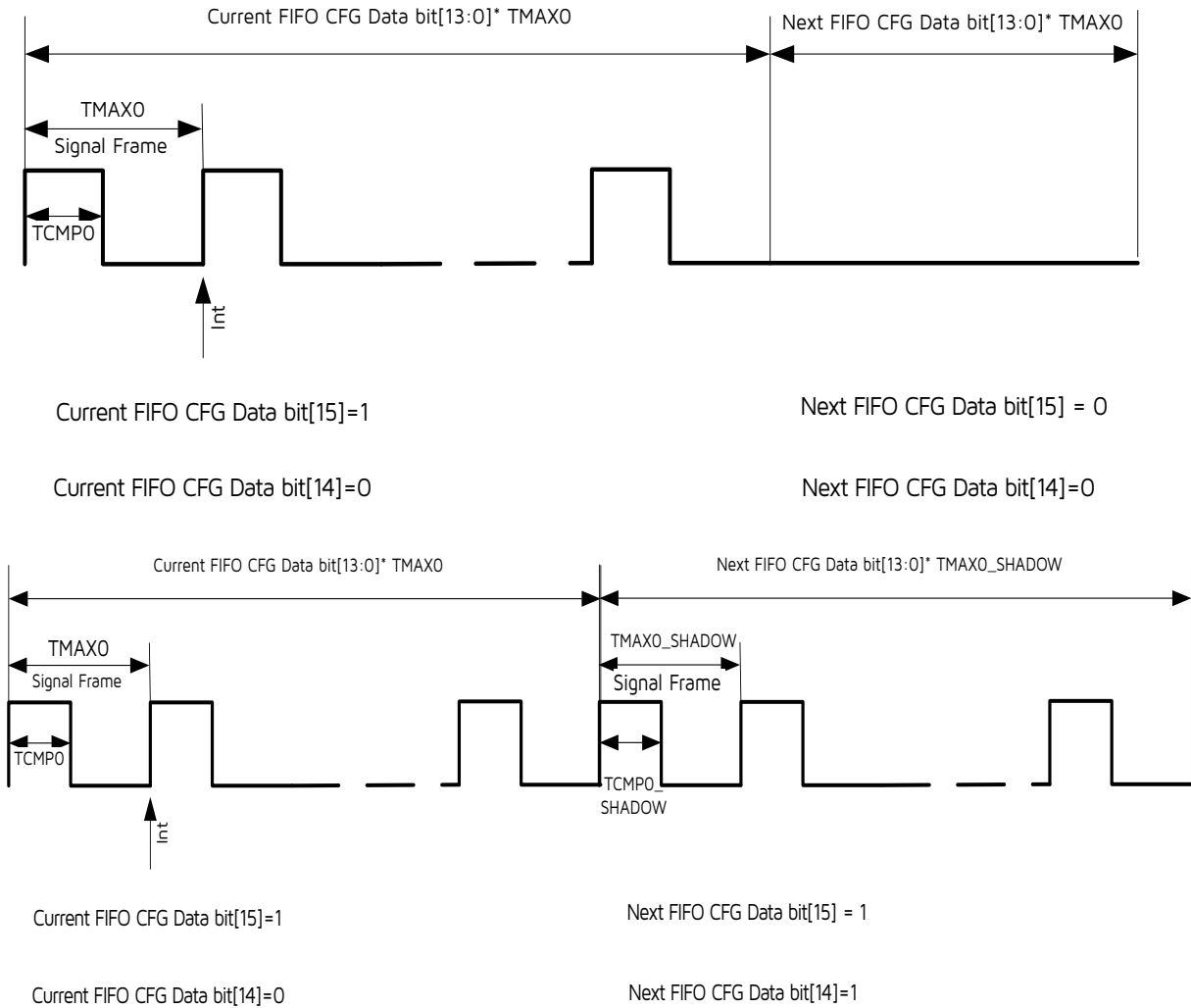

When “FIFO CFG Data” is configured in FIFO and PWM0 is enabled via PWM_ENO[0], the configured waveforms will be output from PWM0 in sequence. As long as FIFO doesn’t overflow, user can continue to add waveforms during IR waveforms sending process, and long IR code that exceeds the FIFO depth can be implemented this way. After all waveforms are sent, FIFO becomes empty, PWM0 will be disabled automatically.

The FIFO_CLR register serves to clear data in FIFO. Writing 1'b1 to this register will clear all data in the FIFO. Note that the FIFO can only be cleared when not in active transmission.

12.4.6 IR DMA FIFO Mode

IR DMA FIFO mode is designed to allow IR transmission of long code patterns without occupation of MCU, and it is designed as a selectable working mode on PWM0. The IR carrier frequency is divided down from the system clock and can be configured as any normal IR frequencies, e.g. 36 kHz, 38 kHz, 40 kHz, or 56 kHz.

Only PWM0 supports IR DMA FIFO mode. PWM_MODE[3:0] should be set as 4b'1111 to select PWM0 IR DMA FIFO mode.

This mode is similar to IR FIFO mode, except that “FIFO CFG Data” is written into FIFO by DMA instead of MCU. User should write the configuration of “FIFO CFG Data” into RAM, and then enable DMA channel 5. DMA will automatically write the configuration into FIFO.

NOTE: In this mode, when DMA channel 5 is enabled, PWM will automatically output configured waveform, without the need to manually enable PWM0 via PWM_ENO (i.e. PWM_ENO[0] will be set as 1'b1 automatically).

12.5 PWM Interrupt

There are 9 interrupt sources from PWM function.

After each signal frame, PWM#n (n = 0 ~ 5) will generate a frame-done IRQ (Interrupt Request) signal.

In Counting mode and IR mode, PWM0 will generate a Pnum IRQ signal after completing a pulse group.

In IR FIFO mode, PWM0 will generate a FIFO mode count IRQ signal when the FIFO_NUM value is less than the FIFO_NUM_LVL, and will generate a FIFO mode stop IRQ signal after FIFO becomes empty.

In IR DMA FIFO mode, PWM0 will generate an IR waveform send done IRQ signal, after DMA has sent all configuration data, FIFO becomes empty and final waveform is sent.

To enable PWM interrupt, the total enabling bit “irq_pwm” should be set as 1'b1. To enable various PWM interrupt sources, PWM_MASK0 and PWM_MASK1 should be set as 1'b1 correspondingly.

Interrupt status can be cleared via register PWM_INT0 and PWM_INT1.

12.6 PWM Center Align Mode

PWM#n (n = 0 ~ 5) support center align mode. For example, PWM0’s center align mode is enabled by setting PWM_CENTER[5:0] as 6'b000001. PWM0 output waveform is shown as below.

Figure 12-7 Center Align Mode

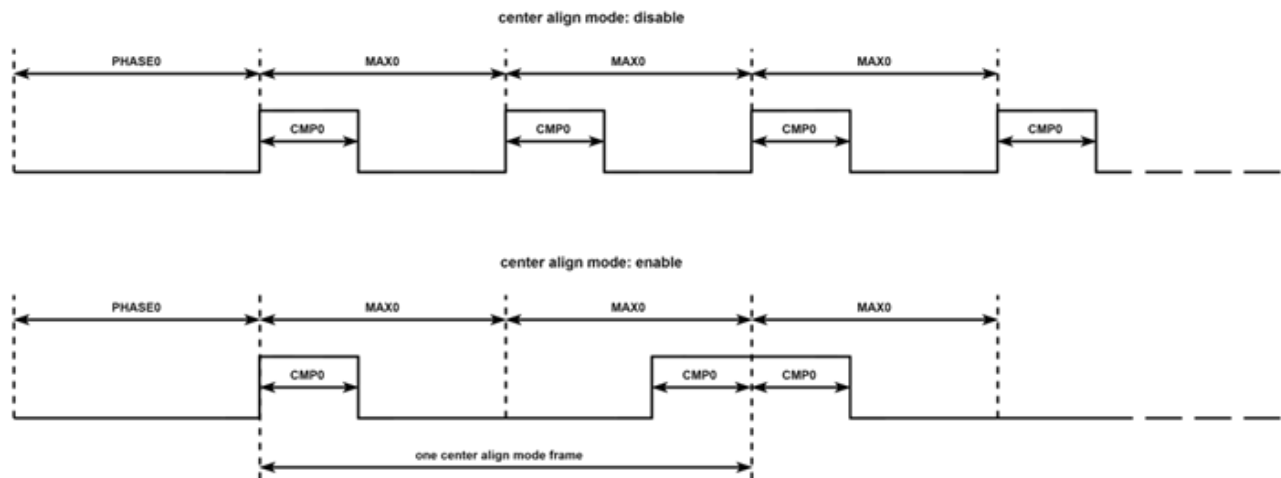

12.7 Register Description

PWM related registers are listed as following. The base address for below registers is 0x80140400.

Table 12-1 PWM Registers

Offset	Type	Description	Default Value
0x00	W	PWM_EN pwm[5:1] enable	0x00
0x01	W	PWM_EN0 pwm0 enable	0x00
0x02	RW	PWM_CLKDIV	0x00
0x03	RW	PWM_MODE [0]:crun_o [1]:catch_o [2]:fifio_mode_en	0x00
0x04	RW	PWM_CC0 invert PWM output	0x00
0x05	RW	PWM_CC1 invert PWM_INV output	0x00
0x06	RW	PWM_CC2 PWM pola	0x00
0x07	RW	MODE32K	0x00
0x14	RW	PWM_TCMPO_L tcmpb0[7:0] bits 7-0 of PWM0's high time or low time	0x00
0x15	RW	PWM_TCMPO_H tcmpb0[15:8] bits 15-8 of PWM0's high time or low time	0x00
0x16	RW	PWM_TMAX0_L tmaxb0[7:0] bits 7-0 of PWM0's cycle time	0x00
0x17	RW	PWM_TMAX0_H tmaxb0[15:8] bits 15-8 of PWM0's cycle time	0x00
0x18	RW	PWM_TCMP1_L tcmpb1_o[7:0] bits 7-0 of PWM1's high time or low time	0x00

Offset	Type	Description	Default Value
0x19	RW	PWM_TCMP1_H tcmpb1_o[15:8] bits 15-8 of PWM1's high time or low time	0x00
0x1a	RW	PWM_TMAX1_L tmaxb1_o[7:0] bits 7-0 of PWM1's cycle time	0x00
0x1b	RW	PWM_TMAX1_H tmaxb1_o[15:8] bits 15-8 of PWM1's cycle time	0x00
0x1c	RW	PWM_TCMP2_L tcmpb2_o[7:0] bits 7-0 of PWM2's high time or low time	0x00
0x1d	RW	PWM_TCMP2_H tcmpb2_o[15:8] bits 15-8 of PWM2's high time or low time	0x00
0x1e	RW	PWM_TMAX2_L tmaxb2_o[7:0] bits 7-0 of PWM2's cycle time	0x00
0x1f	RW	PWM_TMAX2_H tmaxb2_o[15:8] bits 15-8 of PWM2's cycle time	0x00
0x20	RW	PWM_TCMP3_L tcmpb3_o[7:0] bits 7-0 of PWM3's high time or low time	0x00
0x21	RW	PWM_TCMP3_H tcmpb3_o[15:8] bits 15-8 of PWM3's high time or low time	0x00
0x22	RW	PWM_TMAX3_L tmaxb3_o[7:0] bits 7-0 of PWM3's cycle time	0x00
0x23	RW	PWM_TMAX3_H tmaxb3_o[15:8] bits 15-8 of PWM3's cycle time	0x00
0x24	RW	PWM_TCMP4_L tcmpb4_o[7:0] bits 7-0 of PWM4's high time or low time	0x00
0x25	RW	PWM_TCMP4_H tcmpb4_o[15:8] bits 15-8 of PWM4's high time or low time	0x00

Offset	Type	Description	Default Value
0x26	RW	PWM_TMAX4_L tmaxb4_o[7:0] bits 7-0 of PWM4's cycle time	0x00
0x27	RW	PWM_TMAXB4_H tmaxb4_o[15:8] bits 15-8 of PWM4's cycle time	0x00
0x28	RW	PWM_TCMP5_L tcmpb5_o[7:0] bits 7-0 of PWM5's high time or low time	0x00
0x29	RW	PWM_TCMP5_H tcmpb5_o[15:8] bits 15-8 of PWM5's high time or low time	0x00
0x2a	RW	PWM_TMAX5_L tmaxb5_o[7:0] bits 7-0 of PWM5's cycle time	0x00
0x2b	RW	PWM_TMAX5_H tmaxb5_o[15:8] bits 15-8 of PWM5's cycle time	0x00
0x2c	RW	PWM_PNUM_L pnumb[7:0]	0x00
0x2d	RW	PWM_PNUM_H pnumb[13:8]	0x00
0x2e	RW	PWM_CENTER [5:0]:center_align [6]:auto_txclr_off [7]:txf_nempty_en	0x00
0x30	RW	PWM_MASK [0]:mask_pwm [1]:mask_fifo [7:2]:mask	0x00
0x31	VOLATILE	PWM_INT [0]:int_pwm,count model interrupt flag [1]:int_fifo_done,int_fifo_done [7:2]:int_flag,w1c too, int_flag[5:0]	0x00
0x32	RW	PWM_MASK_LVL	0x00
0x33	VOLATILE	PWM_INT_LVL	0x00

Offset	Type	Description	Default Value
0x34	VOLATILE	PWM_CNT0_L	0x00
0x35	VOLATILE	PWM_CNT0_H	0x00
0x36	VOLATILE	PWM_CNT1_L	0x00
0x37	VOLATILE	PWM_CNT1_H	0x00
0x38	VOLATILE	PWM_CNT2_L	0x00
0x39	VOLATILE	PWM_CNT2_H	0x00
0x3a	VOLATILE	PWM_CNT3_L	0x00
0x3b	VOLATILE	PWM_CNT3_H	0x00
0x3c	VOLATILE	PWM_CNT4_L	0x00
0x3d	VOLATILE	PWM_CNT4_H	0x00
0x3e	VOLATILE	PWM_CNT5_L	0x00
0x3f	VOLATILE	PWM_CNT5_H	0x00
0x40	R	PWM_NCNT_L	0x00
0x41	R	PWM_NCNT_H	0x00
0x44	RW	PWM_TCMP_FSK_L	0x00
0x45	RW	PWM_TCMP_FSK_H	0x00
0x46	RW	PWM_TMAX_FSK_L	0x00
0x47	RW	PWM_TMAX_FSK_H	0x00
0x48	R	PWM_RDAT_LO	0x00
0x49	R	PWM_RDAT_H0	0x00
0x4a	R	PWM_RDAT_L1	0x00
0x4b	R	PWM_RDAT_H1	0x00
0x4c	RW	PWM_FIFO_LVL	0x00
0x4d	VOLATILE	PWM_TX_CTRL	0x10
0x4e	W	CLR_TXFIFO	0x00

13 SAR ADC

The SoC integrates one SAR ADC module, which can be used to sample analog input signals such as battery voltage and temperature sensor.

The diagram of SAR ADC module is shown in figure below.

Figure 13-1 Diagram of ADC

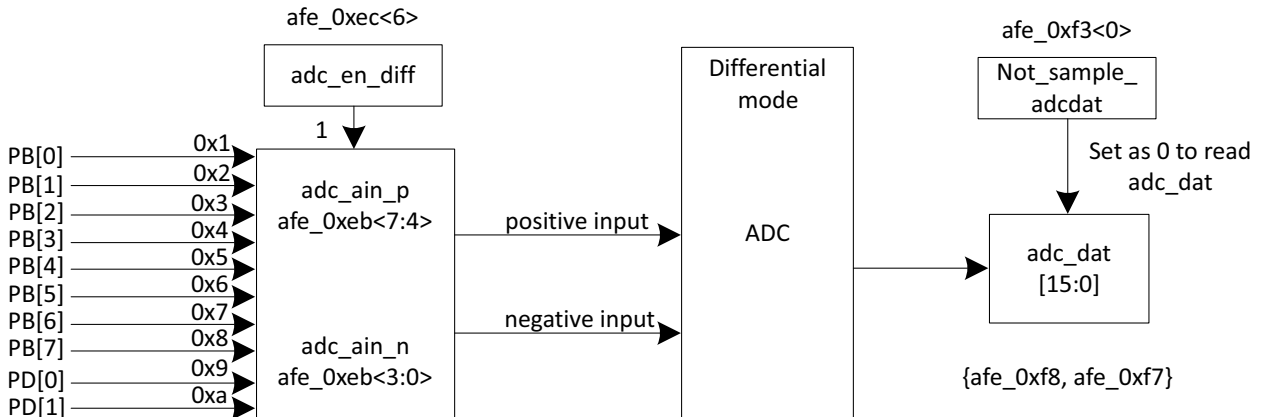

NOTE:

- If the IO voltage of GPIO is configured as 1.8V, the sampling range of GPIO signal is 0 ~ 1.8 V; the maximum input voltage for ADC detection cannot be higher than 1.8V. If it is needed to detect a voltage higher than 1.8V, an external voltage divider circuit is required.
- If the IO voltage of GPIO is configured as 3.3V, the sampling range of GPIO signal is 0 ~ 3.3 V.

13.1 Power On/Down

The SAR ADC is disabled by default. To power on the ADC, the analog register `adc_pd` (afe_0xfc<5>) should be set as 1'b0.

13.2 ADC Clock

The ADC clock is derived from external 24 MHz crystal source, with frequency dividing factor configured via the analog register `adc_clk_div` (afe_0xf4<2:0>).

$$\text{ADC clock frequency (marked as } F_{\text{ADC_clk}}) = 24\text{MHz}/(\text{adc_clk_div}+1)$$

NOTE: The ADC clock is fixed at 4 MHz and should not be modified.

13.3 ADC Control in Auto Mode

13.3.1 Set Max State and Enable Channel

The SAR ADC supports Misc channel which consists of one "Set" state and one "Capture" state.

- The analog register `r_max_scnt` (`afe_0xf2<5:4>`) serves to set the max state index. As shown below, the `r_max_scnt` should be set as `0x02`.
- The Misc channel can be enabled via `r_en_misc` (`afe_0xf2<2>`).

13.3.2 "Set" State

The length of "Set" state for the Misc channel is configurable via the analog register `r_max_s` (`afe_0xf1<3:0>`).

$$\text{"Set" state duration (marked as } T_{sd}\text{)} = r_max_s / 24\text{MHz.}$$

Each "Set" state serves to set ADC control signals for the Misc channel via corresponding analog registers, including:

- `adc_en_diff`: `afe_0xec<6>`. MUST set as `1'b1` to select differential input mode.
- `adc_ain_p`: `afe_0xeb<7:4>`. Select positive input in differential mode.
- `adc_ain_n`: `afe_0xeb<3:0>`. Select negative input in differential mode.
- `adc_vref`: `afe_0xea<1:0>`. Set reference voltage V_{REF} . ADC maximum input range is determined by the ADC reference voltage.
- `adc_sel_ai_scale`: `afe_0xfa<7:6>`. Set scaling factor for ADC analog input as 1 (default), or 1/8.

By setting this scaling factor, ADC maximum input range can be extended based on the V_{REF} .

For example, suppose the V_{REF} is set as 1.2V:

Since the scaling factor is 1 by default, the ADC maximum input range should be 0-1.2V (negative input is GND) / -1.2V~+1.2V (negative input is ADC GPIO pin).

If the scaling factor is set as 1/8, in theory ADC maximum input range should change to 0-9.6V (negative input is GND) / -9.6V~+9.6V (negative input is ADC GPIO pin). But limited by input voltage of the chip's PAD, the actual range is narrower.

- `adc_res`: `afe_0xec<1:0>`. Set resolution as 8/10/12/14 bits.

ADC data is always 16-bit format no matter what the resolution is set. For example, 14 bits resolution indicates ADC data consists of 14-bit valid data and 2-bit sign extension bit.

- `adc_tsamp`: `afe_0xee<3:0>`. Set sampling time which determines the speed to stabilize input signals.

$$\text{Sampling time (marked as } T_{s\text{amp}}\text{)} = \text{adc_tsamp} / F_{\text{ADC_clk}}.$$

The lower sampling cycle, the shorter ADC convert time.

13.3.3 "Capture" State

For the Misc channel, at the beginning of its "Capture" state, a "run" signal is issued automatically to start an ADC sampling and conversion process; at the end of "Capture" state, ADC output data is captured.

- The length of "Capture" state is configurable via the analog register `r_max_mc[9:0]` (`afe_0xf1<7:6>`, `afe_0xef<7:0>`).

$$\text{"Capture" state duration for Misc channel (marked as } T_{cd}\text{)} = r_max_mc / 24\text{MHz.}$$

- The "VLD" bit (`afe_0xf6<0>`) will be set as `1'b1` at the end of "Capture" state to indicate the ADC data is valid, and this flag bit will be cleared automatically.

- The 16-bit ADC output data can be read from the analog register adc_dat[15:0] (afe_0xf8<7:0>, afe_0xf7<7:0>) while the afe_0xf3<0> is set as 1'b0 (default). If the afe_0xf3<0> is set as 1'b1, the data in the afe_0xf8 and afe_0xf7 won't be updated.

NOTE: The total duration " T_{td} ", which is the sum of the length of "Set" state and "Capture" state, determines the sampling rate. Sampling frequency (marked as F_s) = $1 / T_{td}$

13.3.4 Usage Case with Detailed Register Setting

This case introduces the register setting details for Misc channel sampling.

In this case, afe_0xf2<2> should be set as 1'b1, so as to enable the Misc channel, while the max state index should be set as "2" by setting afe_0xf2<5:4> as 0x2.

The total duration (marked as T_{td}) = $(1 * r_{max_s} + 1 * r_{max_mc}) / 24\text{MHz}$.

Table 13-1 Overall Register Setting

Function	Register Setting
Power on the ADC	afe_0xfc<5> = 1'b0
Set F_{ADC_clk} (ADC clock frequency) as 4MHz	afe_0xf4<2:0> = 5 $F_{ADC_clk} = 24\text{MHz}/(5+1) = 4\text{ MHz}$
Enable the Misc channel	afe_0xf2<2> = 1'b1
Set the max state index as "2"	afe_0xf2<5:4> = 2'b10
Set T_{sd} ("Set" state duration)	afe_0xf1<3:0> = 10 $T_{sd} = r_{max_s}/24\text{ MHz} = 10/24\text{ MHz} = 0.417\text{ }\mu\text{s}$
Set T_{cd} ("Capture" state duration)	afe_0xf1<7:6> = 1, afe_0xef<7:0> = 0xea $T_{cd} = r_{max_mc}[9:0]/24\text{ MHz} = 490/24\text{ MHz} = 20.417\text{ }\mu\text{s}$
T_{td} (total duration)	$T_{td} = (1 * r_{max_s} + 1 * r_{max_mc}) / 24\text{ MHz} = 500/24\text{ MHz} = 20.83\text{ }\mu\text{s}$
F_s (Sampling frequency)	$F_s = 1 / T_{td} = 24\text{ MHz}/500 = 48\text{ kHz}$
Set differential input	afe_0xec<6> = 1
Set input channel	afe_0xeb = 0x56 Select PB[4] as positive input and PB[5] as negative input
Set reference voltage V_{REF}	afe_0xea<1:0> = 2 $V_{REF} = 1.2\text{V}$
Set scaling factor for ADC analog input	afe_0xfa<7:6> = 0 scaling factor: 1 ADC maximum input range: -1.2V ~ +1.2V

Function	Register Setting
Set resolution	afe_0xec<1:0> = 3 resolution: 14 bits
Set T_{samp} (determines the speed to stabilize input before sampling)	afe_0xee<3:0> = 3 $T_{\text{samp}} = \text{adc_tsamp} / F_{\text{ADC_clk}} = 12/4 \text{ MHz} = 3 \mu\text{s}$

13.4 Battery Voltage Sampling

The SoC use GPIO input for battery voltage sampling, by setting register afe_0xeb<7:4>, user can choose which GPIO port to use. Register afe_0xeb<3:0> should be set to 0xf.

NOTE:

- When IO voltage of GPIO is set to 1.8V, they cannot be used for battery voltage sampling. Users can use external voltage divider instead, the details refer to the Driver SDK Developer Handbook for this chip.
- When IO voltage of GPIO is set to 3.3V, the sampling range of VBAT is 1.8 ~ 4.3 V.

13.5 Register Table

Table 13-2 SAR ADC Registers

Address	Default Value	Description
afe_0xea<1:0>	00	Select V_{REF} for M channel 0x0: 0.6V 0x1: 0.9V 0x2: 1.2V 0x3: rsvd
afe_0xea<7:2>	-	rsvd

Address	Default Value	Description
afe_0xeb<3:0>	0000	Select negative input for Misc channel: 0x0: No input 0x1: B[0] 0x2: B[1] ... 0x8: B[7] 0x9: C[4] 0xa: C[5] 0xb: rsvd 0xc: rsvd 0xd: rsvd 0xe: new tempensor_n (Temperature sensor negative output) 0xf: Ground
afe_0xeb<7:4>	0000	Select positive input for Misc channel: 0x0: No input 0x1: B[0] 0x2: B[1] ... 0x8: B[7] 0x9: C[4] 0xa: C[5] 0xb: rsvd 0xc: rsvd 0xd: rsvd 0xe: new tempensor_n (Temperature sensor negative output) 0xf: vbatdiv
afe_0xec<1:0>	11	Set resolution for Misc channel 0x0: 8bits 0x1: 10bits 0x2: 12bits 0x3: 14bits
afe_0xec<5:2>	-	rsvd
afe_0xec<6>	0	Select input mode for Misc channel. 0: rsvd 1: differential mode
afe_0xec<7>	-	rsvd

Address	Default Value	Description
afe_0xee<3:0>	0000	Number of ADC clock cycles in sampling phase for Misc channel to stabilize the input before sampling: 0x0: 3 cycles 0x1: 6 cycles 0x2: 9 cycles 0x3: 12 cycles ... 0xf: 48 cycles
afe_0xef<7:0>	-	r_max_mc[9:0] serves to set length of "capture" state for Misc channel. r_max_s serves to set length of "set" state for Misc channel. Note: State length indicates number of 24M clock cycles occupied by the state.
afe_0xf0<7:0>	-	
afe_0xf1<3:0>	-	
afe_0xf1<5:4>	-	
afe_0xf1<7:6>	-	
afe_0xf2<0>	-	rsvd
afe_0xf2<1>	-	rsvd
afe_0xf2<2>	-	Enable Misc channel sampling. 1: enable
afe_0xf2<3>	0	0: enable write to core 1: disable write to core
afe_0xf2<5:4>	00	Set total length for sampling state machine (i.e. max state index)
afe_0xf2<7>	-	rsvd
afe_0xf3<0>	0	0: sample ADC data to afe_0xf8 and afe_0xf7 1: not sample ADC data to afe_0xf8 and afe_0xf7
afe_0xf3<1>	0	Dwa_en for analog
afe_0xf3<7:2>	-	rsvd
afe_0xf4<2:0>	011	ADC clock (derive from external 24M crystal) ADC clock frequency = 24M/(adc_clk_div+1)
afe_0xf4<7:3>-	-	rsvd
afe_0xf5<7:0>	-	rsvd
afe_0xf6<0>	-	[0]: vld, ADC data valid status bit (This bit will be set as 1 at the end of capture state to indicate the ADC data is valid, and will be cleared when set state starts.)

Address	Default Value	Description
afe_0xf6<7:1>	-	rsvd
afe_0xf7<7:0>		Read only [7:0]: Misc adc dat[7:0]
afe_0xf8<7:0>		Read only [7:0]: Misc adc_dat[15:8]
afe_0xf9<1:0>	-	rsvd
afe_0xf9<3:2>	0	Vbat divider select sel_vbatdiv[1:0] Vbatdiv 0x0 OFF 0x1 VBAT/4 0x2 VBAT/3 0x3 VBAT/2
afe_0xf9<5:4>	00	rsvd
afe_0xf9<7:6>	-	rsvd
afe_0xfa<1:0>	0	Comparator preamp bias current trimming itrim_preamp[1:0] lbias 0x0 75% 0x1 100% 0x2 125% 0x3 150%
afe_0xfa<3:2>	0	Vref buffer bias current trimming itrim_vrefbuf[1:0] lbias 0x0 75% 0x1 100% 0x2 125% 0x3 150%
afe_0xfa<5:4>	0	Vref buffer bias current trimming itrim_vcmbuf[1:0] lbias 0x0 75% 0x1 100% 0x2 125% 0x3 150%

Address	Default Value	Description
afe_0xfa<7:6>	0	Analog input pre-scaling select sel_ai_scale[1:0]: scaling factor 0x0: 1 0x1: rsvd 0x2: 1/4 0x3: rsvd
afe_0xfc<4>	0	rsvd
afe_0xfc<5>	1	Power down ADC 1: Power down 0: Power up

14 Temperature Sensor

The SoC integrates a temperature sensor and it's used in combination with the SAR ADC to detect real-time temperature.

The temperature sensor is disabled by default. The analog register afe_0x06<2> should be set as 1'b0 to enable the temperature sensor.

Table 14-1 Analog Register for Temperature Sensor

Address	Type	Description	Default Value
afe_0x06	R/W	[2]: pd_temp_sensor_3v, Power down of temp sensor: 1: Power down, 0: Power up	0x1

The temperature sensor embeds a pnp transistor. It takes the real-time temperature (T) as input, and outputs voltage drop (V_{EB}) signals of PNP transistor as positive and negative output respectively.

Figure 14-1 Block Diagram of Temperature Sensor

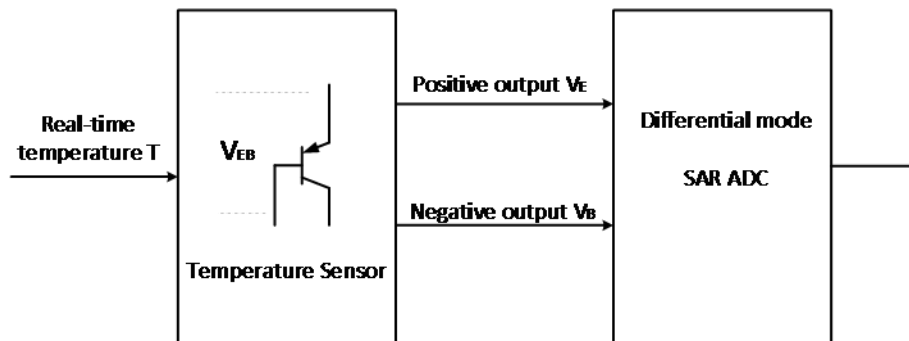

The voltage drop V_{EB} signals is determined by the real-time temperature T, as shown below:

$$\begin{aligned}
 V_{EB} &= 884mV - 1.4286mV/^{\circ}C * (T - (-40^{\circ}C)) \\
 &= 884mV - 1.4286mV/^{\circ}C * (T + 40^{\circ}C)
 \end{aligned}$$

In this formula, "884mV" indicates the value of V_{EB} at the temperature of -40 .

To detect the temperature, the positive and negative output of the temperature sensor should be enabled as the input channels of the SAR ADC. The ADC will convert the V_{EB} signals into digital signal.

The ADC should be configured as differential mode, and the positive and negative output of the temperature sensor should be configured as differential input of the ADC. The ADC should initiate one operation and obtain one output signal (ADCOUT); therefore,

$$V_{EB} = \frac{884mV}{N} + \frac{V_{REF}}{N}$$

In the formula, "N" and " V_{REF} " indicate the selected resolution and reference voltage of the SAR ADC.

Then the real-time temperature T can be calculated according to the V_{EB} .

15 Low Power Comparator

The SoC embeds a low power comparator. This comparator takes two inputs: input derived from external PortB (PB[1]-PB[7]), and reference input derived from internal reference, PB[0], PB[3] or float.

By comparing the input voltage multiplied by selected scaling coefficient with reference input voltage, the low power comparator will output high or low level accordingly.

Figure 15-1 Block Diagram of Low Power Comparator

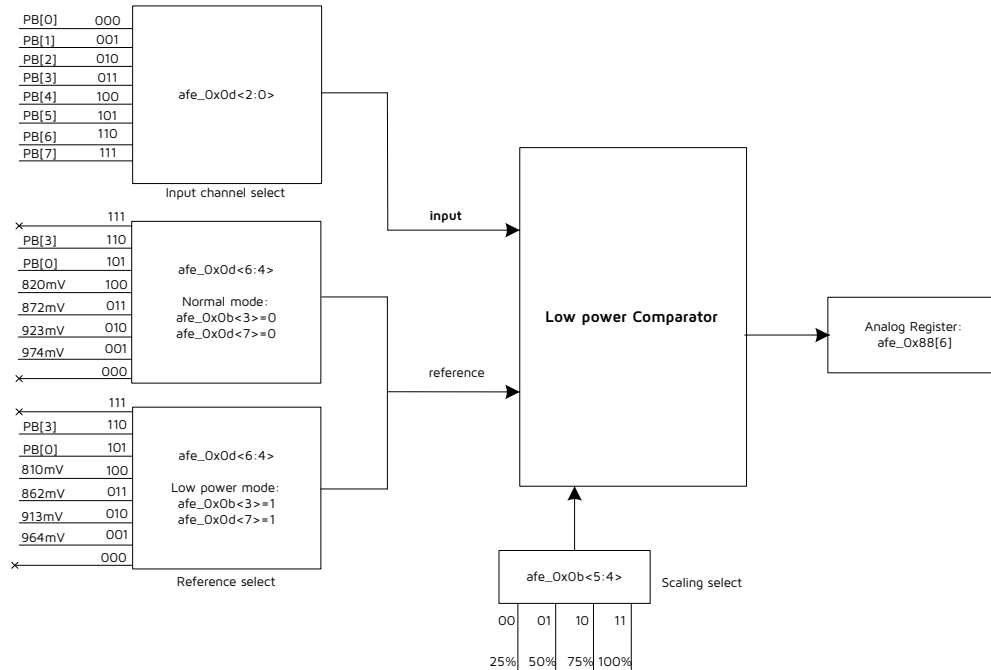

NOTE: The difference between the input level and the wake-up level needs to be greater than 100mV when using Low Power Comparator wake-up mode to enter sleep.

15.1 Power On/Down

The low power comparator is powered down by default.

The analog register `afe_0x07<3>` serves to control power state of the low power comparator: By clearing this bit, this comparator will be powered on; by setting this bit to 1'b1, this comparator will be powered down.

To use the low power comparator, first set `afe_0x07<3>` as 1'b0, then the 32K RC clock source is enabled as the comparator clock.

15.2 Select Input Channel

Input channel is selectable from the PortB (PB[1] ~ PB[7]) via the analog register `afe_0x0d<2:0>`.

15.3 Select Mode and Input Channel for Reference

Generally, it's needed to clear both the `afe_0x0b<3>` and `afe_0x0d<7>` to select the normal mode. In normal mode, the internal reference is derived from UVLO and has higher accuracy, but current bias is larger (10 μ A); reference voltage input channel is selectable from internal reference of 974 mV, 923 mV, 872 mV and 820 mV, as well as PB[0], PB[3] and float.

To select the low power mode, both the `afe_0x0b<3>` and `afe_0x0d<7>` should be set as 1'b1. In low power mode, the internal reference is derived from Bandgap and has lower accuracy, but current bias is decreased to 50 nA; reference voltage input channel is selectable from internal reference of 964 mV, 913 mV, 862 mV and 810 mV, as well as PB[0], PB[3] and float.

15.4 Select Scaling Coefficient

Equivalent reference voltage equals the selected reference input voltage divided by scaling coefficient.

The analog register `afe_0x0b<5:4>` serves to select one of the four scaling options: 25%, 50%, 75% and 100%.

15.5 Low Power Comparator Output

The low power comparator output is determined by the comparison result of the value of [input voltage *scaling] and reference voltage input. The comparison principle is shown as below:

- If the value of [input voltage *scaling] is larger than reference voltage input, the output will be low ("0").
- If the value of [input voltage *scaling] is lower than reference voltage input, the output will be high ("1").
- If the value of [input voltage *scaling] equals reference voltage input, or input channel is selected as float, the output will be uncertain.

User can read the output of the low power comparator via the analog register `afe_0x88[6]`.

The output of the low power comparator can be used as signal to wakeup system from low power modes.

15.6 Register Description

Table 15-1 Analog Register Related to Low Power Comparator

Address	Description	Default Value
<code>afe_0x06<1></code>	Power down of low current comparator: 1: Power down 0: Power up	0x1
<code>afe_0x0b<3></code>	Reference mode select: 1: ref from BG; 1: ref from UVLO.	0x1

Address	Description	Default Value
afe_0x0b<5:4>	Reference voltage scaling: 11: 100% 10: 75% 01: 50% 00: 25%	0x1
afe_0x0c<3>	pd_diff, low power comparator diff mode disable: 1: single; 0: diff	0x1
afe_0x0d<2:0>	channel select of lc comparator: 000: B[0] 001: B[1] 010: B[2] 011: B[3] 100: B[4] 101: B[5] 110: B[6] 111: B[7]	000
afe_0x0d<3>	lc_comp_vbus_inen, inner detect point enable: 1: enable; 0: disable	000
afe_0x0d<6:4>	lc_comp_refsel<2:0> channel select of lc comparator: reference from bg reference from uvlo 0x000 -> float 0x000 -> float 0x001 -> 974mV 0x001 -> 1088mV 0x010 -> 923mV 0x010 -> 1036mV 0x011 -> 872mV 0x011 -> 983mV 0x100 -> 820mV 0x100 -> 931mV 0x101 -> B[0] 0x101 -> B[0] 0x110 -> B[1] 0x110 -> B[1]	000
afe_0x0d<7>	lc_comp_pd_10u power down of 10u current to voltage reference 1: power down; 0: active	000
afe_0x4b<3>	comparator wakeup enable	0x0

Address	Description	Default Value
afe_0x4d<0>	pd_lc_comp auto 1: auto power down low power comparator	0x0

16 Secure Boot, Firmware Encryption and Debug Lock

The TLSR9528 supports secure boot function. Secure boot ensures that the chip boots from the secure code in unmodifiable Boot-ROM at the time of booting, and that the code is verified, encrypted and decrypted. The secure boot process allows the user to form a trusted security chain based on a secure root key, ensuring that all code executed is trusted and secure.

An important function of secure boot is public key verification. Public key verification means that the user signs the firmware with the private key. The chip side uses the public key to verify the signature before running the firmware. The firmware will run only if the verification passes. The signature verification uses the Elliptic Curve Digital Signature Algorithm (ECDSA). The public key verification ensures that only the code that passes the verification can be executed.

In order to protect the code from being cloned or being stored in plaintext, code encryption can be used. The firmware is encrypted by hardware when it is downloaded to flash. The encryption adopts an AES-128-like Light Crypto encryption algorithm. When the chip is running, it will decrypt the firmware in real time.

The TLSR9528 also supports option for disabling the debug port so that during mass production, the debug port is disabled and as a result, hackers will not have means to access any registers or memories within the chip through debug interfaces.

16.1 Key Management

Figure 16-1 Key Management

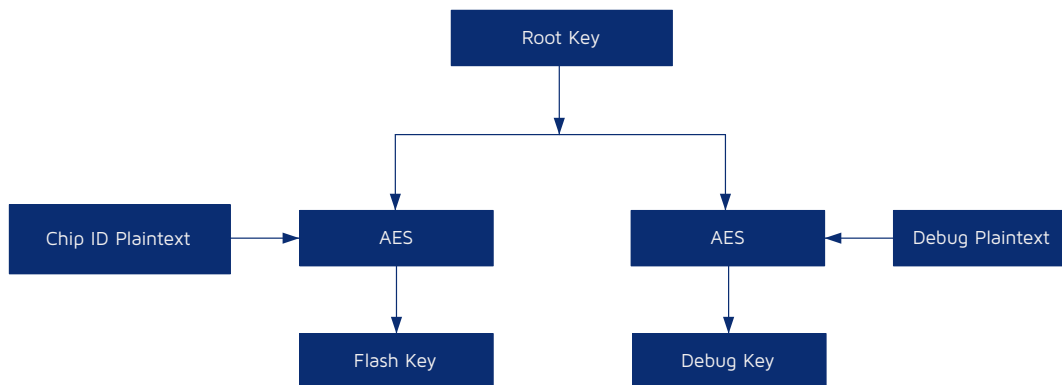

The keys used for real-time firmware encryption (Flash key) and for debug port lock (Debug key), are generated from the root key by the AES module through the above key derivation structure. The root key can be set by the customer to control its own product security derivation structures. The root key is a customer provisioned and controlled key that ensures that the customer has full control of the encryption and debug lock process. The flash key is derived from the root key and the chip ID plaintext through an AES-based derivation process and is unique per chip; the debug key is derived from the root key and the debug plaintext through AES-based derivation process, the debug plaintext is provided by customers as a means to identify their unique debug key and is unique per customer or per customer project. The flash key is the key for real-time encryption and decryption of the firmware, and the debug key is the key used to enable the debug interfaces when the debug interfaces are disabled.

16.2 Flash Space and eFuse Definition

16.2.1 Flash Space in Secure Boot Mode

Figure 16-2 Flash Space for Secure Boot

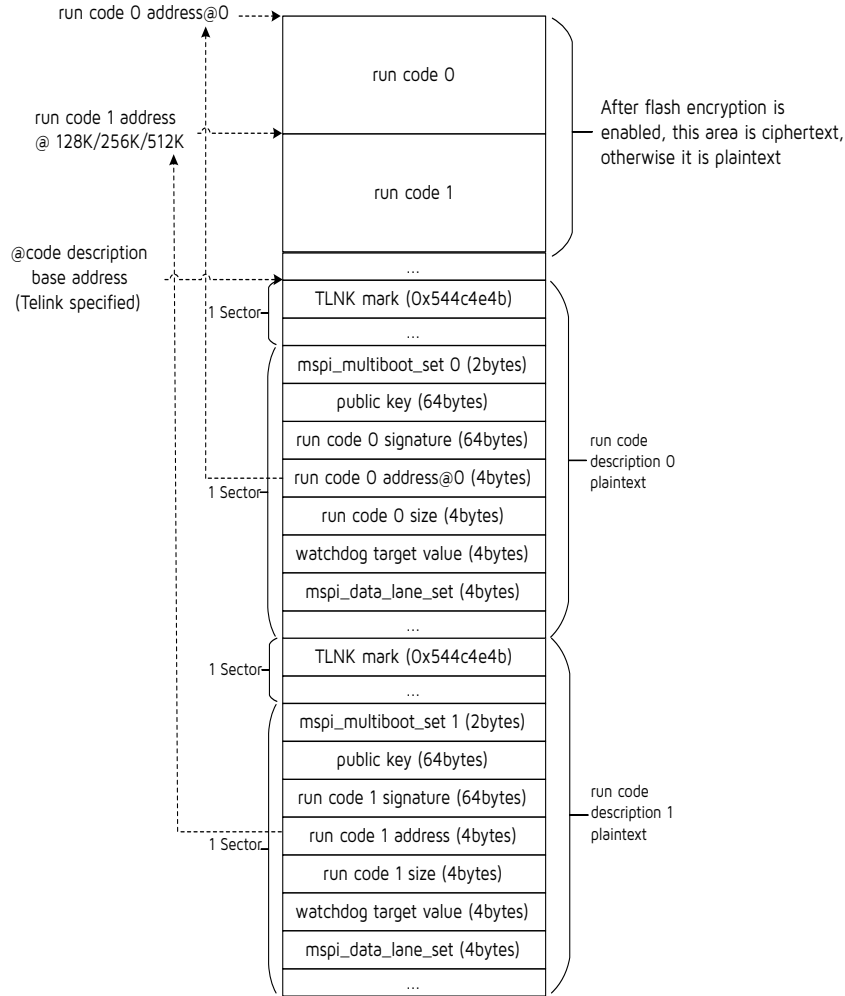

The flash may contain several segments of data including code 0 & 1, and their corresponding code description block 0 & 1. When allocating flash, each segment area should not overlap, and the first address of each segment address is recommended to be aligned with the smallest erase unit of flash. The code description block is only present if secure boot with firmware signature verification is enabled.

The code, which has a fixed starting address of 0, is the firmware code to be executed. It is in plaintext if firmware encryption is not enabled; if the firmware encryption is enabled, the code is stored as ciphertext (encrypted firmware). The code is automatically loaded after power on, and the user should leave a corresponding size of flash space.

The code description block provides information about the corresponding firmware code.

- The Telink Mark is a fixed string pattern stored in the register of 0x544c4e4b. Bootloader only execute the corresponding code 0 or code 1 with a valid corresponding Telink Mark, and realize switching the code to be executed.
- The `mspi_multiboot_set` is used to set parameters related to run code address.
- The public key is the public key used to verify the code signature.
- The run code signature is the calculated signature over the running code.
- The run code address is the starting address of the running code.
- The run code size is the length of the code field in Bytes.
- The watchdog target value is the watchdog capture value. This value should be set large enough to allow firmware signature verification process to finish before watchdog resets, please use the default value provided by Telink.
- The `mspi_data_lane_set` is to set the desired MSPI width for the running data. The data lane mode can be selected from 2-lane and 4-lane, please use the default value provided by Telink.

16.2.2 eFuse Definition in Secure Boot Mode

The eFuse definition in secure boot mode is shown in the table below. Please also check [4.1.3 eFuse](#) for details on eFuse.

Table 16-1 eFuse Data for Secure Boot

Definition	Size (Bit)	Description
<code>root_key</code>	128	Root key, a customer provided key for Flash key and Debug key derivation
<code>chip_ID_plaintext</code>	128	Unique chip ID
<code>Debug_plaintext</code>	128	Debug plaintext, is a text string provided by the customer to control the debug lock feature for a customer project
<code>public_key_hash</code>	256	Public key hash, is the hash calculated over the public key used by customer for firmware signature verification. Once provisioned by the customer, it cannot be changed. It is used by the Boot-ROM to verify that the correct public key for firmware signature verification is used.

16.2.3 Use of Debug Key

If the user wants to re-enable debug after the debug port is locked, he needs to send the 129-bit debug key sequence (128-bit debug key with one more bit of 0) according to the single wire protocol by high byte first to enable debug port.

16.3 Usage

The chip has two modes: normal mode and secure boot mode. The two modes are configured by compatible identifier in eFuse `Security_Feature` field. If bit [29] is 1, it is secure boot mode. If bit [29] is 0, it is normal mode.

Normal Mode

In this mode, the firmware plaintext runs from address offset 0K/128K/256K/512K bytes of Flash; Flash encryption function can be enabled in normal mode by setting Security_Feature bit[31].

Secure Boot Mode

There are following four configurations in secure boot mode:

1. No encryption or signature verification: bit[31] Flash encryption disabled, bit[29] secure boot mode set to secure mode (1).

In this mode, neither firmware encryption nor firmware signature verification is enabled. This configuration is not recommended in Secure Boot mode.

2. Encryption only without signature verification: bit[31] Flash encryption enabled, bit[29] secure boot mode set to secure mode (1).

In this mode, the firmware stored on the Flash is encrypted. It is decrypted in real-time during running. This configuration is also not recommended in Secure Boot mode. For Flash encryption only, user is recommended to use the Normal Mode with Flash encryption option.

3. Signature verification only without encryption: bit[31] Flash encryption disabled, bit[29] secure boot mode set to secure mode (1).

In this mode, firmware is stored in plaintext on the Flash, but the code description information is used to verify its signature.

4. Encryption and signature verification: bit[31] Flash encryption enabled, bit[29] secure boot mode set to secure mode (1).

In this mode, firmware is stored in ciphertext on the Flash, and the code description information is used to verify its signature on the original plaintext.

17 AES

The SoC embeds AES module with encryption and decryption function. The input 128-bit plaintext in combination of key is converted into the final output ciphertext via encryption; the 128-bit ciphertext in combination of key can also be converted into 128-bit plaintext via decryption.

Software stores the block to encrypt, at AESPTR address in the SRAM. The block size to encrypt is always considered to equal 128-bit. Software defines the input key setting its value in AESKEY<> registers. Once the settings done, Software starts AES-128 use by writing a 1 in AES_START. On normal termination, the Software receives a crypt_irq. When the process ends the Software can find encrypted data at AESPTR+16 address as shown in figure below (considering byte address memory).

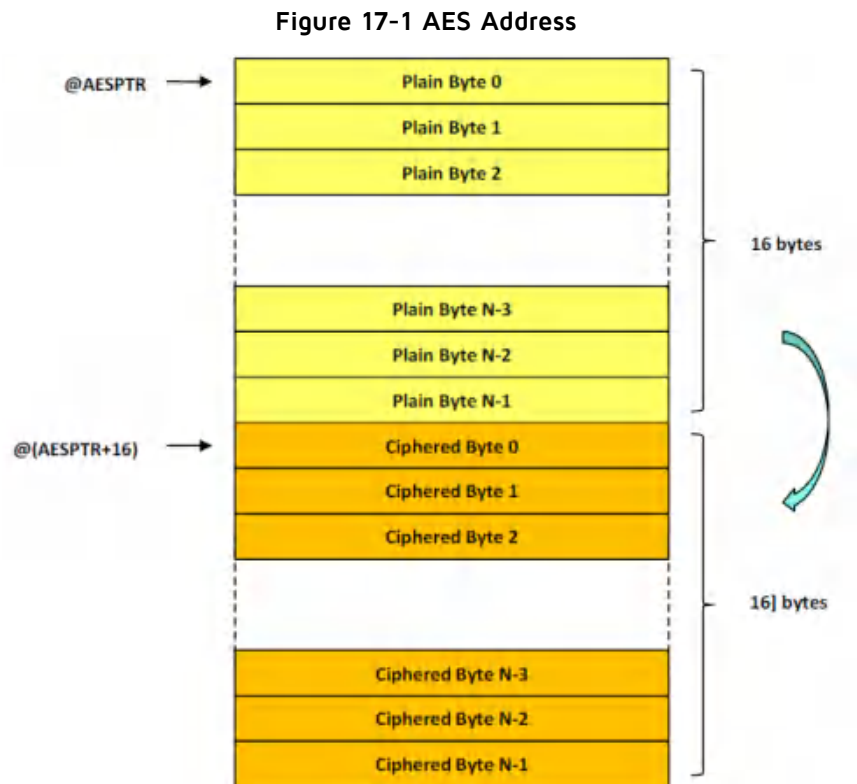

The AES related registers are listed as following. The base address for the registers below is 0x80160000.

Table 17-1 AES Related Registers

Address Offset	Type	Description	Reset Value
0xb0	R/W	AESCNTL [0] AES_START [1] AES_MODE	0x00
0xb4	R/W	[7:0] AESKEY31_00, AES encryption 128-bit key. Bit 7 down to 0	0x00
0xb5	R/W	[7:0] AESKEY31_01, AES encryption 128-bit key. Bit 15 down to 8	0x00
0xb6	R/W	[7:0] AESKEY31_02, AES encryption 128-bit key. Bit 23 down to 16	0x00

Address Offset	Type	Description	Reset Value
0xb7	R/W	[7:0] AESKEY31_03, AES encryption 128-bit key. Bit 31 down to 24	0x00
0xb8	R/W	[7:0] AESKEY63_32_0, AES encryption 128-bit key. Bit 39 down to 32	0x00
0xb9	R/W	[7:0] AESKEY63_32_1, AES encryption 128-bit key. Bit 47 down to 40	0x00
0xba	R/W	[7:0] AESKEY63_32_2, AES encryption 128-bit key. Bit 55 down to 48	0x00
0xbb	R/W	[7:0] AESKEY63_32_3, AES encryption 128-bit key. Bit 63 down to 56	0x00
0xbc	R/W	[7:0] AESKEY95_64_0, AES encryption 128-bit key. Bit 71 down to 64	0x00
0xbd	R/W	[7:0] AESKEY95_64_1, AES encryption 128-bit key. Bit 79 down to 72	0x00
0xbe	R/W	[7:0] AESKEY95_64_2, AES encryption 128-bit key. Bit 87 down to 80	0x00
0xbf	R/W	[7:0] AESKEY95_64_3, AES encryption 128-bit key. Bit 95 down to 88	0x00
0xc0	R/W	[7:0] AESKEY127_96_0, AES encryption 128-bit key. Bit 103 down to 96	0x00
0xc1	R/W	[7:0] AESKEY127_96_1, AES encryption 128-bit key. Bit 111 down to 104	0x00
0xc2	R/W	[7:0] AESKEY127_96_2, AES encryption 128-bit key. Bit 117 down to 112	0x00
0xc3	R/W	[7:0] AESKEY127_96_3, AES encryption 128-bit key. Bit 127 down to 118	0x00
0xc4	R/W	[7:0] AESPTR0, Pointer to the memory zone where the block to cipher using AES-128 is stored.	0x00
0xc5	R/W	[7:0] AESPTR1	0x00

18 Public Key Engine (PKE)

The TLSR9528 embeds Public Key Engine (PKE) Standard Performance acceleration module and this section describes its function and use.

18.1 Calculation Model Overview

The Public Key Engine (PKE) contains a low-power version of the public key cryptography acceleration engine, which can support a variety of asymmetric cryptographic algorithms. It should be noted that to fully implement SM2, ECDSA and ECDH functions, a random number generator module and a Hash module are required. In this version, the following features are available:

- Support modular operations: modular addition, modular subtraction, modular multiplication, modular exponentiation, modular inverse
- Support elliptic curve point operations: point addition, point doubling, point multiplication, and verify whether the point is on the curve
- Support large number operations: large number multiplication

With software drivers, it can support multiple public key algorithms, including:

- RSA (supports CRT): operand length 512 ~ 1024 bits, 32-bit step
- ECC (supports ECDH and ECDSA, prime field): 192, 224, 256 and 384 bits
- Ed25519/X25519
- SM2

18.2 Function Description

18.2.1 Module Description

PKE is designed to accelerate large number operations involved in RSA and Elliptic Curve Cryptography (ECC) operations in public key cryptography. Recently PKE can directly complete modular exponentiation in RSA and point multiplication in ECC. The CPU can query the operation of the PKE by polling or interrupting. The PKE includes one program memory unit (ROM), one instruction arithmetic unit (IEU), one 32-bit arithmetic unit (ALU), two pseudo-double-ended data RAMs, one register combination with interface module.

According to different register configurations, the PKE can complete the following operations of different precisions:

- RSA: length 512 ~ 1024 bits, 32-bit step
- ECC (prime field): length 192, 224, 256, and 384 bits
- Ed25519/X25519
- SM2

In addition, the calculation of the PKE is finished in the form of Microcode and the Microcode is stored in the program storage unit. Therefore, different kind of public key cryptographic calculations can be implemented by pouring different microcode into the program storage unit. For instance, a high security public key algorithm instruction can be injected into a program storage unit in the PKE module in a SoC with high security requirements. Certainly these arithmetic instructions can be written to the ROM with a large program memory

unit capacity. The CPU makes real-time calls according to different usage scenarios. The full microcode size is approximately 2 KB.

Figure 18-1 Block Diagram of PKE Module

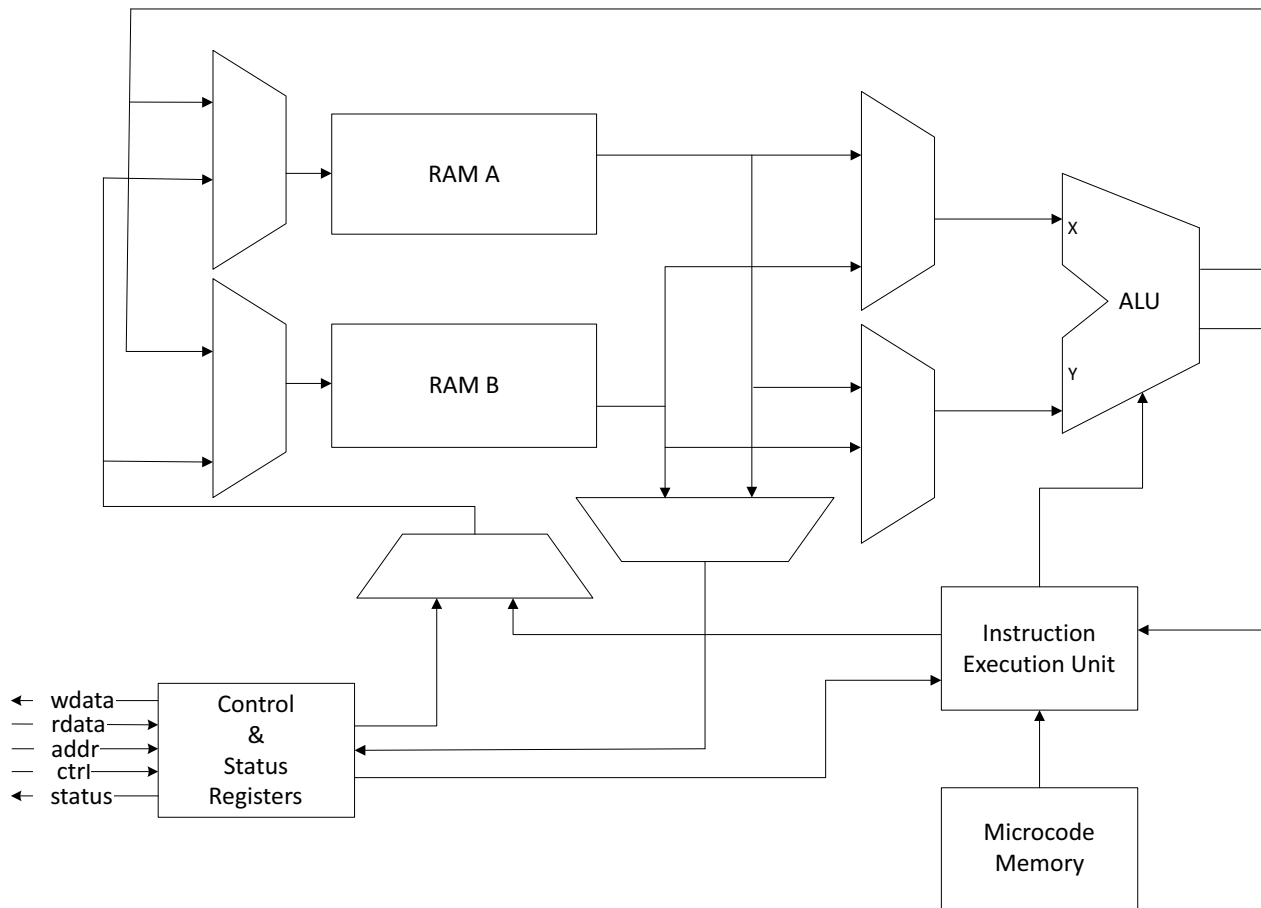

18.2.2 Software Interface (Programming Model)

The interfaces of the PKE are all mapped into the bus address space. The block of address mapping space mainly contains all the operands that the CPU can access. These operands contain modulus, power exponents, partial intermediate variables, and so on. In addition to this, the address map also contains control and status registers. The CPU can configure and monitor the PKE module through these control and status registers.

In the operations supported by PKE, the operands are also 192 bits at minimum. Therefore, it will encounter the problem of big-endian and little-endian when putting data into data RAM in the CPU or DMA. In the PKE module, words are arranged following an order of little-endian.

In PKE, the smallest operand is 32 bits (1 word), because the current ALU bit width input is 32 bits. If the operand is not word aligned, the high bit needs to be filled as 0.

After the PKE receives the start command, it starts the operation. During the operation, the host computer can query the current running state through the status register, or interrupt the current operation through the control register. In addition, the result of partial intermediate operations can be obtained by accessing the data RAM address.

The host computer can obtain the result of target operation finish by PKE through polling or interrupting. Data RAM supports word aligned and does not support byte alignment.

Table 18-1 Dual Port RAM Address Map

First Address of Operand	ECC			RSA			
	256 Bits	512 Bits	1024 Bits	512 Bits	1024 Bits	2048 Bits	4096 Bits
A0	0x0400	0x0400	0x0400	0x0400	0x0400	0x0400	0x400
A1	0x0424	0x0444	0x0484	0x0444	0x0484	0x0504	0x604
A2	0x0448	0x0488	0x0508	0x0488	0x0508	0x0608	0x808
A3	0x046C	0x04CC	0x058C	0x04CC	0x058C	0x070C	0xA0C
A4	0x0490	0x0510	0x0610	0x0510	0x0610	0x0810	0xC10
A5	0x04B4	0x0554	0x0694	-	-	-	-
A6	0x04D8	0x0598	0x0718	-	-	-	-
A7	0x04FC	0x05DC	0x079C	-	-	-	-
A8	0x0520	0x0620	0x0820	-	-	-	-
A9	0x0544	0x0664	0x08A4	-	-	-	-
B0	0x1000	0x1000	0x1000	0x1000	0x1000	0x1000	0x1000
B1	0x1024	0x1044	0x1084	0x1044	0x1084	0x1104	0x1204
B2	0x1048	0x1088	0x1108	0x1088	0x1108	0x1208	0x1408
B3	0x106C	0x10CC	0x118C	0x10CC	0x118C	0x130C	0x160C
B4	0x1090	0x1110	0x1210	0x1110	0x1210	0x1410	0x1810
B5	0x10B4	0x1154	0x1294	-	-	-	-
B6	0x10D8	0x1198	0x1318	-	-	-	-
B7	0x10FC	0x11DC	0x139C	-	-	-	-
B8	0x1120	0x1220	0x1420	-	-	-	-
B9	0x1144	0x1264	0x14A4	-	-	-	-

The above table shows the address assignment of two RAMs in ECC mode and RSA mode. The operand registers are distributed in two blocks of data RAM, using the prefixes A and B to distinguish the two blocks of RAM. The addresses listed in the table are all CPU addressable addresses, RAM A has an address offset of 0x400, and RAM B has an address offset of 0x1000. The actual space used by RAM will be larger than the space listed in the table and some intermediate variable storage is not open to the CPU.

Data will be stored in the mode of little-endian in RAM.

18.3 Register Description

The base address for the following PKE related registers is 0x80110000.

Table 18-2 PKE Related Registers

Offset	Type	Description	Default Value
0x00	W1S	PKE_CTRL [0]: Start Trigger PKE to start operation 0: No effect 1: PKE will start operation in the next clock cycle. The operations performed by PKE are decided by PKE_CFG and PKE_MC_PTR.	0x00
0x04	WR	PKE_CFG0 [7:0] partial_radix_lo {partial_radix_hi, partial_radix_lo} determines the bit width that the operation really needs to use in the operation. The value of this field indicates the number of bits, and the bit width of the operand is partial_radix. For example, if BASE_RADIX = 2 and PARTIAL_RADIX = 192 (0xC0), then the bit width of the operand is 192 bits. If you need to perform secp192r1 operations, you need to configure BASE_RADIX and PARTIAL_RADIX as shown in this example. If you want to use other bit-width operands, follow the above formula to configure BASE_RADIX and PARTIAL_RADIX. If the operands are all word-aligned, then the values of [15:11] are all 0x0. If you want to perform secp521r1 operation, then configure BASE_RADIX as 4, and PARTIAL_RADIX as 521 (0x209).	0x00
0x05	RW	PKE_CFG1 [4:0] partial_radix_hi	0x01

Offset	Type	Description	Default Value
0x06	RW	<p>PKE_CFG2</p> <p>[2:0] base_radix</p> <p>This field indicates the bit width base of operations. At the same time, the base also indicates the space required for storing the operand in RAM.</p> <p>For RSA modular operations, the value of this field should be 4, 5 or 6</p> <p>For ECC point operations, the value of this field should be 2, 3 or 4</p> <p>2: 256 bits</p> <p>3: 512 bits</p> <p>4: 1024 bits</p> <p>5: 2048 bits</p> <p>6: 4096 bits</p> <p>Other: Reserved</p>	0x02
0x08	RW	<p>PKE_MC_PTRO</p> <p>[7:0] addr_lo</p> <p>{addr_hi, addr_lo} PKE microcode execution entry</p> <p>This register can be rewritten only when PKE is not working; any write operation when PKE is working will be ignored.</p> <p>During the operation of PKE, this field will update in real time; it always points to the address of the next instruction to be executed.</p> <p>It should be noted that the instructions are all word aligned.</p> <p>Therefore, the lowest 2 bits of this field are both 0.</p>	0x00
0x09	RW	<p>PKE_MC_PTR1</p> <p>[3:0] addr_hi</p>	0x00
0x0c	WOC	<p>PKE_RISR</p> <p>[0] core_ris</p> <p>CPU mode interrupt indicator</p> <p>0: PKE generates no interrupts in CPU mode.</p> <p>1: PKE has completed operations in CPU mode, interrupt generated.</p>	0x00

Offset	Type	Description	Default Value
0x10	RW	PKE_IMCR [0] core_irqen Enable CPU mode interrupt 0: Disable PKE from generating interrupts in CPU mode 1: Enable PKE to generate interrupts in CPU mode	0x00
0x14	RO	PKE_MISR [0] core_mi CPU mode interrupt output 0: PKE does not generate interrupts in CPU mode 1: PKE has generated interrupts in CPU mode	0x00
0x24	RO	PKE_RT_CODE [3:0] stop_log This field is used to indicate the reason for PKE stop. If PKE is stopped because the operation is completed, then the value of this field is 0. If the value of this field is non-zero, the operation of PKE has not been completed and some exceptions have been encountered, which require external processing and the results are not available. [0]: Normal stop [1]: Termination request received (CTRL.STOP is high) [2]: No valid modular inverse result [3]: Point is not on the curve (CTRL.CMD: PVER) [4]: Invalid Microcode others: Reserved	0x00
0x50	RW	PKE_EXE_CFG [0] iaff_r0 Enable RO input's affine coordinate system form, this bit is only valid for ECC operations In ECC operations, RO is the position of A0, A1 and B2 In RSA operations, RO is the position of A0 0: The input point is a point in the Jacobian coordinate system; when it involves modular multiplication, if the bit is low, the point in its scope will be converted to the Jacobian coordinate system before the operation 1: The input point is a point on the affine coordinate system	0x15

Offset	Type	Description	Default Value
		<p>[1] imon_r0</p> <p>Enable R0 input's Montgomery form</p> <p>In ECC operations, R0 is the position of A0, A1 and B2</p> <p>In RSA operations, R0 is the position of A0</p> <p>0: The input data is in ordinary form; when it comes to modular multiplication, if the bit is low, the number in its scope will be converted to Montgomery form before the operation</p> <p>1: The input data is in Montgomery form</p>	
		<p>[2] iaff_r1</p> <p>Enable R1 input's affine coordinate system form, this bit is only valid for ECC operations.</p> <p>In ECC operations, R1 is the position of B0, B1 and A2</p> <p>In RSA operations, R1 is the B0 position</p> <p>0: The input point is a point on the Jacobian coordinate system; when it involves modular multiplication, if the bit is low, the point in its scope will be converted to the Jacobian coordinate system before the operation</p> <p>1: The input point is a point on the affine coordinate system</p>	
		<p>[3] imon_r1</p> <p>Enable R1 input's Montgomery form</p> <p>In ECC operations, R1 is the position of B0, B1 and A2</p> <p>In RSA operations, R1 is the B0 position</p> <p>0: The input data is in normal form; when it comes to modular multiplication, if the bit is low, the number in its scope will be converted to Montgomery form before the operation</p> <p>1: The input data is in Montgomery form</p>	
		<p>[4] oaff</p> <p>Enable output's affine coordinate system form, this bit is only valid for ECC operations</p> <p>0: The output point is a point on the Jacobian coordinate system</p> <p>1: The output point is a point on the affine coordinate system</p>	
		<p>[5] omon</p> <p>Enable output's Montgomery form</p> <p>0: The output result is in normal form</p> <p>1: The output result is in Montgomery form</p>	

Offset	Type	Description	Default Value
0xfc	R	PKE_RBG_VERSION0 [3:0] mir: Sub version number. [7:4] mar: Main version number	0x10
0xfe	R	PKE_RBG_VERSION2 [7:0] project_lo {project_hi, project_lo} Project number	0x06
0xff	R	PKE_RBG_VERSION3 [7:0] project_hi	0xef

19 PTA Interface

The TLSR9528 supports a Packet Traffic Arbitration (PTA) interface to facilitate co-existence with 802.11 WLAN. The TLSR9528 supports a 2/3/4-wire BLE PTA interface and 3/4-wire BT PTA interface. Regarding the PTA's usage, the 2-wire BLE PTA can use any GPIO which has function of ble/bt_activity plus any other GPIO; the 3-wire BLE/BT PTA must use GPIO pins which are defined as ble/bt_activity, ble/bt_status and wlan_deny by the user, the 4-wire BLE/BT PTA must use GPIO pins which are defined as ble/bt_activity, ble/bt_status and wlan_deny by the user plus any other GPIO. The detailed GPIO configuration refers to [Table 10-1 GPIO Pad Function Mux](#).

19.1 BLE Two-Wire Signaling

Figure 19-1 BLE Two-Wire Signaling

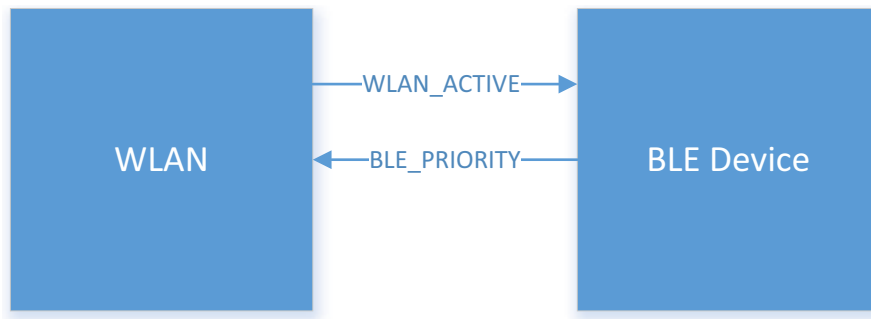

WLAN_ACTIVE:

The WLAN_ACTIVE signal is asserted by WLAN controller when 802.11b/g packets are actively being transmitted or received. The BLE device avoids transmitting low-priority packets that are likely to cause interference with the 802.11b/g activity.

BLE_PRIORITY:

The BLE_PRIORITY signal should be asserted by the BLE device during high-priority transmit or receive activity. When this signal is asserted, WLAN device defers (or aborts) some or all of its transmissions.

The WLAN_ACTIVE signal is judged by the software.

Figure 19-2 Example of BLE Two-Wire PTA Timing Diagram

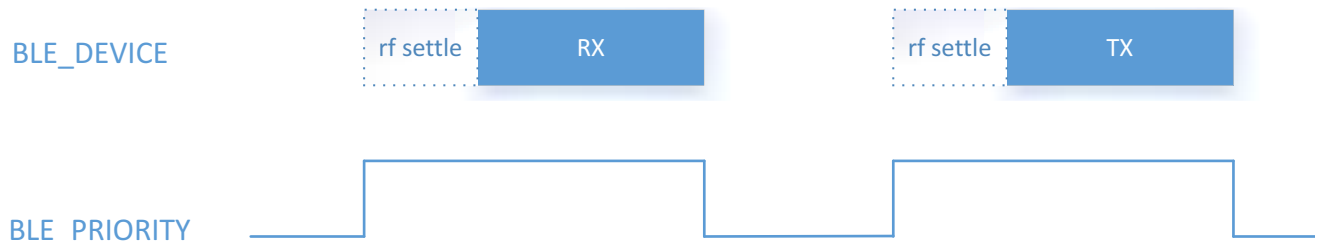

19.2 BLE Three-Wire or Four-Wire Signaling

Figure 19-3 BLE Three-Wire or Four-Wire Signaling

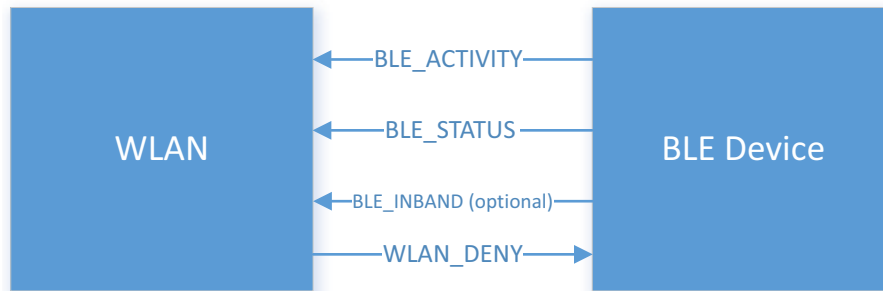

BLE_ACTIVITY:

The BLE device should assert BLE_ACTIVITY for the duration of a “transaction”. This usually corresponds to a transmit-receive or receive-transmit pair. This signal is asserted the time t1 before RF settle operation of first BLE RX/TX packet.

BLE_STATUS:

At the same time as asserting BLE_ACTIVE, the BLE device should assert BLE_STATUS if the transaction is considered to be high priority. After the time t2 the signal should be changed to indicate whether or not the BLE device is transmitting (asserted) or receiving (de-asserted). This signal must be updated prior to transmission or reception to indicate any change of direction.

BLE_INBAND (optional):

This signal is optional and is only of benefit if there is sufficient isolation between the radios to support simultaneous operation on non-overlapping frequencies. The BLE device asserts BLE_INBAND (asserted by software) if any of the channels used in the transaction overlap the 802.11b/g frequencies.

WLAN_DENY:

The WLAN controller drives WLAN_DENY to indicate whether the requested BLE transaction is allowed or denied (which should be effective within the time t1 after asserting BLE_ACTIVE) to determine the activity direction. If the signal is asserted, the BLE device does not start the transaction.

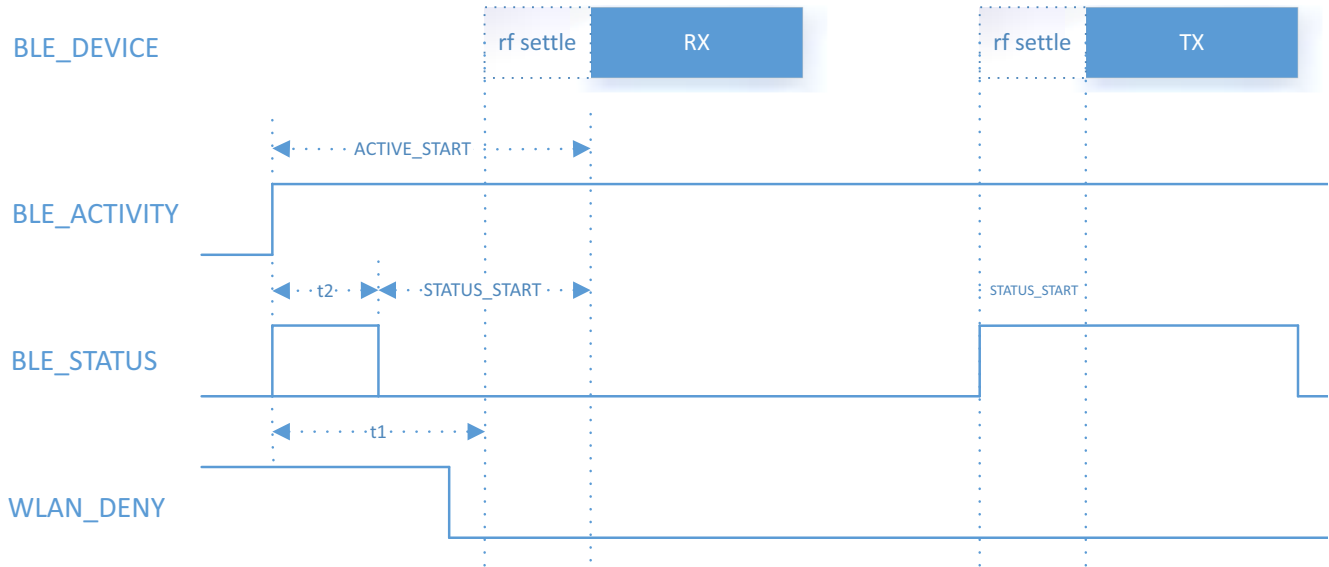
Figure 19-4 Example of BLE Four-Wire PTA Timing Diagram

The two registers below are used to configure t1/t2:

Table 19-1 Register Configuration for t1/t2

Address	Name	Type	Description	Default Value
0xf12	r_t_coex_t1	RW	<p>[7:0]: Corresponds to t1 in Figure 19-4 above. Specifies the time after assertion of BLE_ACTIVITY signal at which the WLAN_DENY should be stable and is sampled by BLE device to determine whether to launch transaction</p> <p>The value of the register should be t1 - 1 (Unit: μs)</p>	0x31
0xf13	r_t_coex_t2	RW	<p>[7:0]: Corresponds to t2 in Figure 19-4 above. Specifies the time after assertion of the BLE_ACTIVITY signal at which the BLE_STATUS signal is changed from transaction priority to packet direction</p> <p>The value of the register should be t2 - 1 (Unit: μs)</p>	0x13

19.3 BT Three-Wire or Four-Wire Signaling

Figure 19-5 BT Three-Wire or Four-Wire Signaling

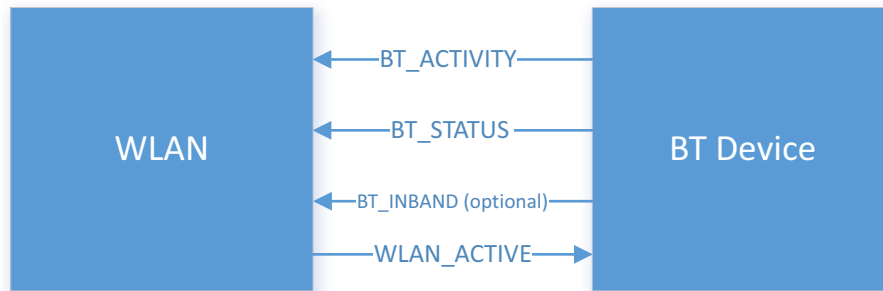

BT_INBAND

It's similar to `FREQ`. This signal is optional and is only of benefit if there is sufficient isolation between the radios to support simultaneous operation on non-overlapping frequencies. The Bluetooth device asserts `BT_INBAND` (with timing corresponding to that of `BT_STATUS` indicating direction) if any of the channels used in the transaction overlap the 802.11b/g frequencies.

BT_ACTIVE

It should be asserted for the duration of a "transaction". This usually corresponds to a transmit-receive or receive-transmit pair, but this may be implemented differently for special activity such as scanning. This signal is typically asserted the time `active_start` before the Bluetooth Packet in the Air.

BT_PRIORITY_STATUS

The Bluetooth device should assert `BT_PRIORITY_STATUS` if the transaction is considered to be high priority at the time `pri_start` before the Bluetooth Packet in the Air. Then at the time `status_start` the signal should be changed to indicate whether or not the Bluetooth device is transmitting (asserted) or receiving (de-asserted). This signal must be updated prior to each slot boundary to indicate any change of direction.

WLAN_ACTIVE

The PTA drives `WLAN_ACTIVE` to indicate whether the requested Bluetooth transaction is allowed or denied (which should be effective before the Bluetooth Packet in the Air) to determine the activity direction. If the signal is asserted, the Bluetooth device does not transmit.

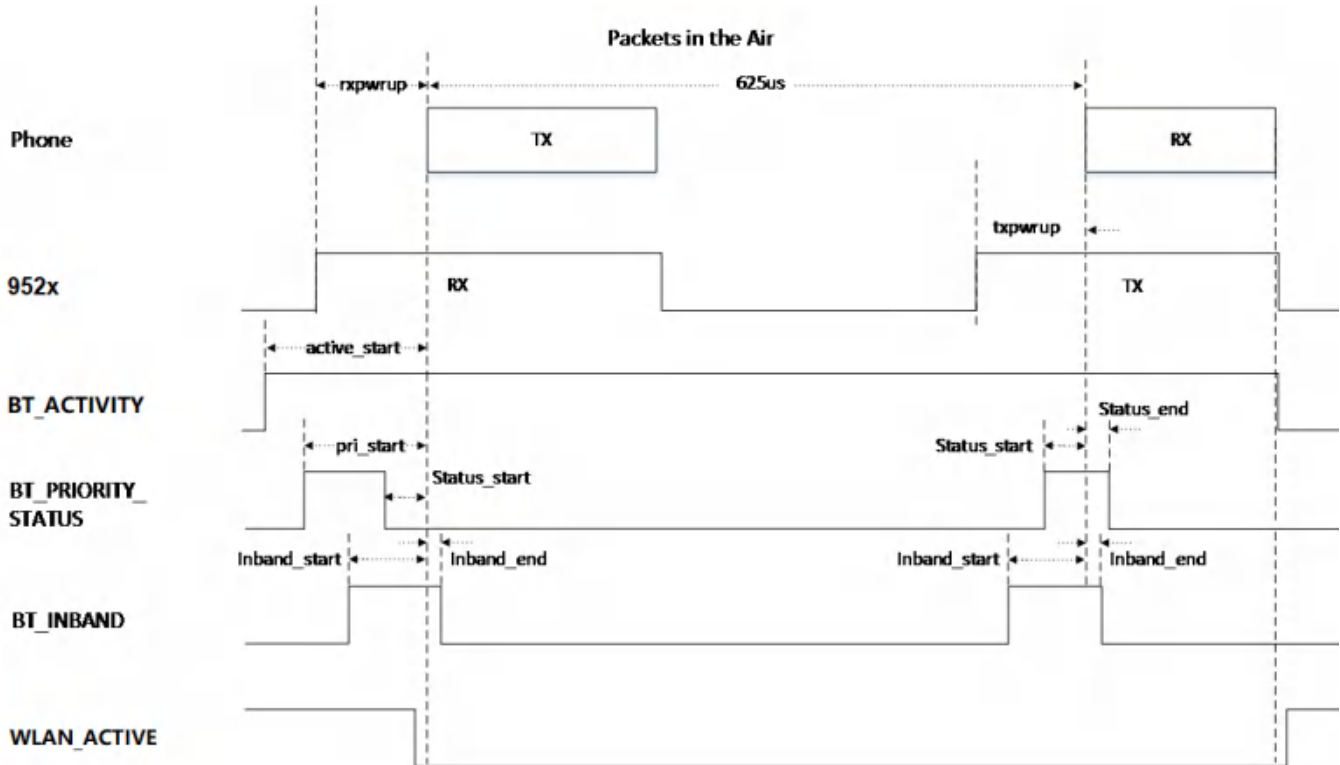
Figure 19-6 Example of BT Four-Wire PTA Timing Diagram

The PTA related registers are listed in the following table. The base address for the following registers is 0x80160000.

Table 19-2 Register Configuration for BT PTA

Address Offset	Register Name	Type	Description	Reset Value
0x280	FWCOEXCNTL00	RW	[7:0]: COEX_TIME_SAMP_VALUE Sample time_cnt value during TRX status	0x6F
0x281	FWCOEXCNTL01	RW	[7:0]: COEX_TIME_PRIORITY_START Priority Start Time of COEX	0x78
0x282	FWCOEXCNTL02	RW	[7:0]: COEX_TIME_ACTIVE_START Active Start Time of COEX	0x82

Address Offset	Register Name	Type	Description	Reset Value
0x283	FWCOEXCNTL03	RW	[0]: COEX_INBAND_TRX_EN Inband used as tx/rx_en enable [1]: COEX_INBAND_INDICATOR Inband value between BT and WIFI [2]: COEX_RXTX_PRIORITY TX/RX_EN Priority: 0: TX High Rx Low 1: RX High Tx Low [3]: COEX_FOUR_WIRE_EN FOUR WIRE COEX Enable	0x0
0x284	FWCOEXCNTL10	RW	[7:0] COEX_TIME_STATUS_END Status End Time of COEX	0x0C
0x285	FWCOEXCNTL11	RW	[7:0] COEX_TIME_STATUS_END Status Start Time of COEX	0x50
0x286	FWCOEXCNTL12	RW	[7:0] COEX_TIME_INBAND_END Inband End Time of COEX	0x0A
0x287	FWCOEXCNTL13	RW	[7:0] COEX_TIME_INBAND_END Inband Start Time of COEX	0x5A

20 Quadrature Decoder

The TLSR9528 embeds one quadrature decoder (QDEC) which is designed mainly for applications such as wheel. The QDEC implements debounce function to filter out jitter on the two phase inputs, and generates smooth square waves for the two phase.

20.1 Input Pin Selection

The QDEC supports two phase input; each input is selectable from the 8 pins of PortD, PortC, PortB and PortA via setting address 0x80140242 (for channel a) / 0x80140243 (for channel b).

Table 20-1 Input Pin Selection

Address 0x80140242/0x80140243	Pin
0	PA[2]
1	PA[3]
2	PB[6]
3	PB[7]
4	PC[2]
5	PC[3]
6	PD[6]
7	PD[7]

NOTE: To use corresponding IO as QDEC input pin, it's needed first to enable GPIO function, enable "IE" (1) and disable "OEN" (1) for this IO.

20.2 Common Mode and Double Accuracy Mode

The QDEC embeds an internal hardware counter, which is not connected with bus.

Address 0x80140247 serves to select common mode or double accuracy mode, 0: common mode; 1: double accuracy mode.

For each wheel rolling step, two pulse edges (rising edge or falling edge) are generated.

If address 0x80140247 is set to 0 to select common mode, the QDEC Counter value (real time counting value) is increased/decreased by 1 only when the same rising/falling edges are detected from the two phase signals.

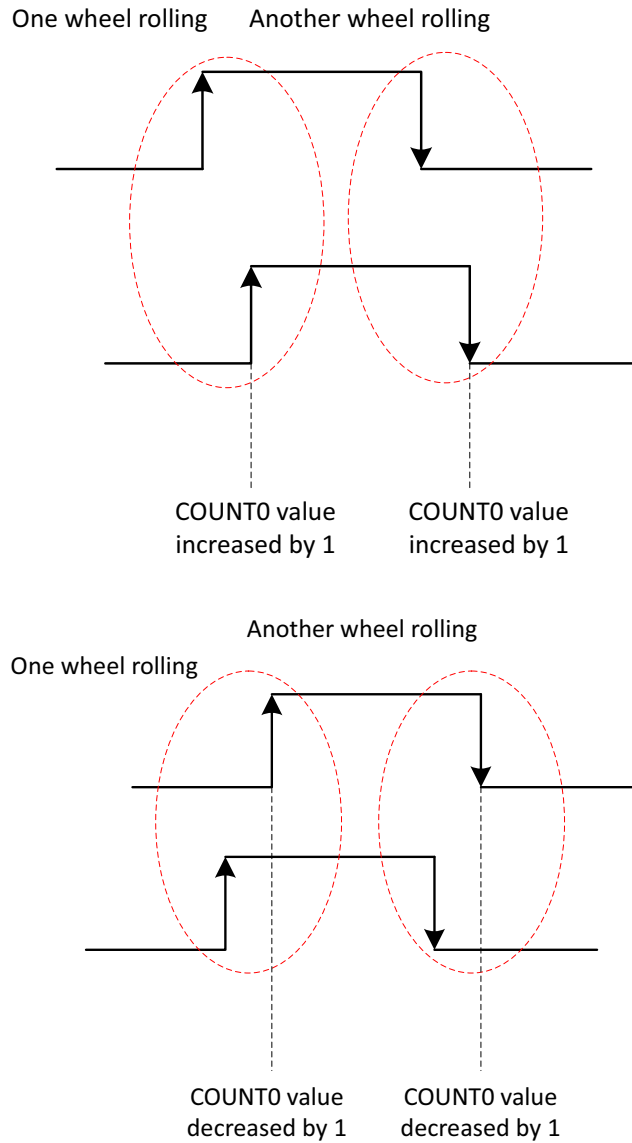
Figure 20-1 Common Mode

If address 0x47[0] is set to 1'b1 to select double accuracy mode, the QDEC Counter value (real time counting value) is increased/decreased by 1 on each rising/falling edge of the two phase signals; the COUNT0 will be increased/decreased by 2 for one wheel rolling.

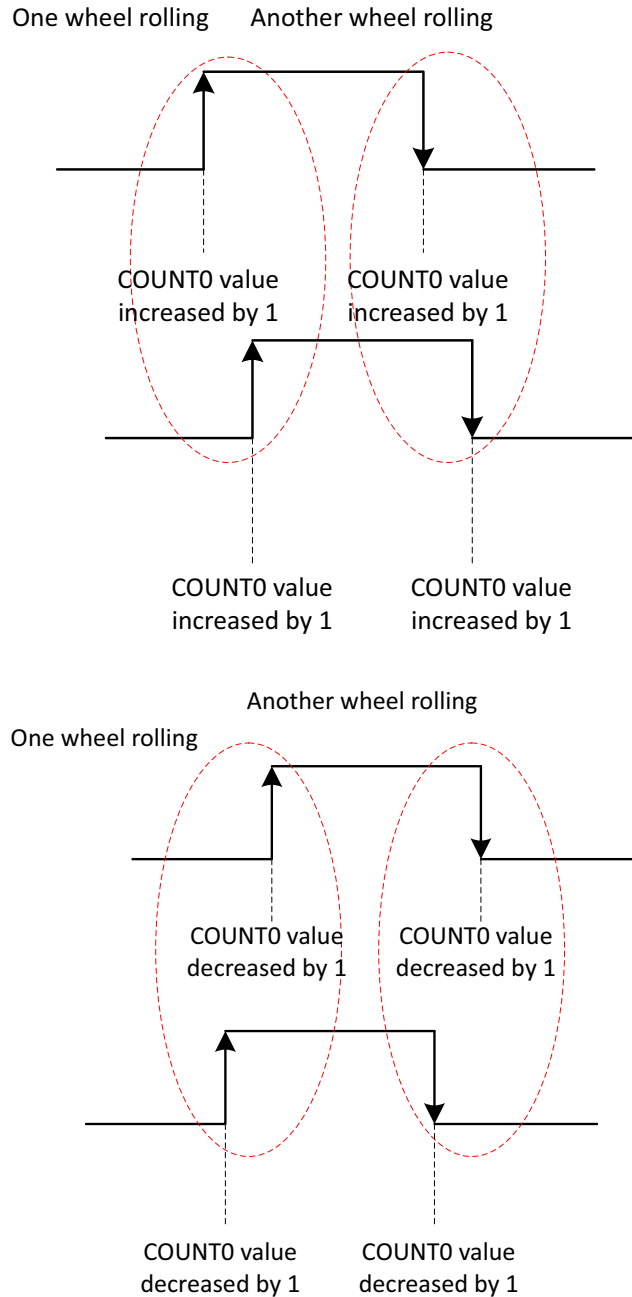
Figure 20-2 Double Accuracy Mode

20.3 Read Real Time Counting Value

Neither can Hardware Counter value be read directly via software, nor can the counting value in address 0x40 be updated automatically.

To read real time counting value, first write address 0x48[0] with 1'b1 to load Hardware Counter data into the ODEC_COUNT register, then read address 0x40.

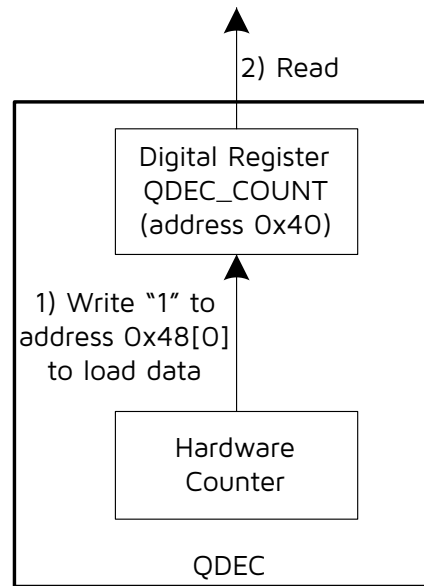
Figure 20-3 Read Real Time Counting Value

20.4 QDEC Reset

Address 0x801401f3[5] serves to reset the QDEC. The QDEC Counter value is cleared to zero.

20.5 Other Configuration

The QDEC supports hardware debouncing. Address 0x41[2:0] serves to set filtering window duration. All jitter with period less than the value will be filtered out and thus does not trigger count change.

Address 0x41[4] serves to set input signal initial polarity.

Address 0x41[5] serves to enable shuttle mode. Shuttle mode allows non-overlapping two phase signals as shown in the following figure.

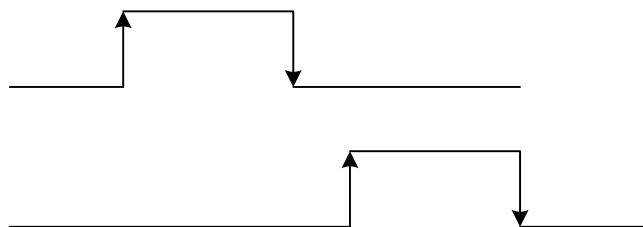
Figure 20-4 Shuttle Mode

20.6 Timing Sequence

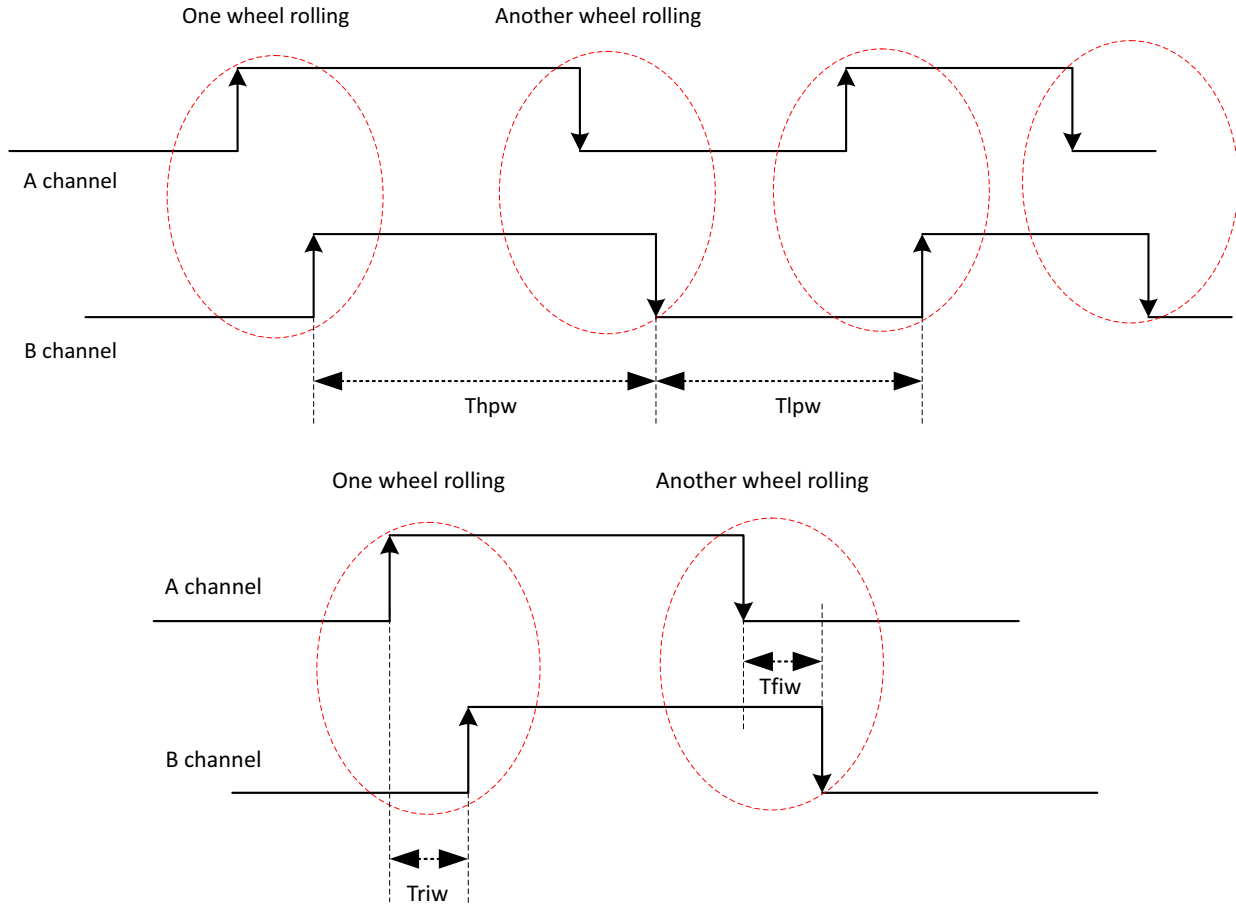
Figure 20-5 Timing Sequence Chart

Table 20-2 Timing

Time Interval	Min Value
T_{hpw} (High-level pulse width)	$2^{(n+1)} * \text{clk_32kHz} * 3$ ($n=0x41[2:0]$)
T_{lpw} (Low-level pulse width)	$2^{(n+1)} * \text{clk_32kHz} * 3$ ($n=0x41[2:0]$)
T_{riw} (Interval width between two rising edges)	$2^{(n+1)} * \text{clk_32kHz}$ ($n=0x41[2:0]$)
T_{fiw} (Interval width between two falling edges)	$2^{(n+1)} * \text{clk_32kHz}$ ($n=0x41[2:0]$)

QDEC module works based on 32 kHz clock to ensure it can work in suspend mode. QDEC module supports debouncing function, and any signal with width lower than the threshold (i.e. " $2^{(n+1)} * \text{clk_32kHz} * 3$ ($n=0x41[2:0]$)) will be regarded as jitter. Therefore, effective signals input from Channel A and B should contain high/low level with width T_{hpw}/T_{lpw} more than the threshold. The $2^n * \text{clk_32kHz}$ clock is used to synchronize input signal of QDEC module, so the interval between two adjacent rising/falling edges from Channel A and B, which are marked as T_{riw} and T_{fiw} , should exceed " $2^{(n+1)} * \text{clk_32kHz}$ ".

Only when the timing requirements above are met, can QDEC module recognize wheel rolling times correctly.

20.7 Register Table

QDEC related registers are listed in the following table. The base address for the following registers is 0x80140240.

Table 20-3 Register Table for QDEC

Address offset	Name	Type	Description	Reset Value
0x00	QDEC_COUNT0	R	QDEC Counting value (read to clear): Pulse edge number	0x00
0x01	QDEC_DBNTIME	RW	[5]: shuttle mode 1 - enable shuttle mode [4]: pola, input signal pola 0 - no signal is low, 1 - no signal is high [2:0]: filter time (can filter $2^n \cdot \text{clk_32k} \cdot 2$ width deglitch)	0x00
0x02	QDEC_CHANNEL_A0	RW	[2:0]: QDEC input pin select for channel A, choose 1 of 8 pins for input channel A 7~0: {PD[7:6], PC[3:2], PB[7:6], PA[3:2]}	0x00
0x03	QDEC_CHANNEL_B0	RW	[2:0]: QDEC input pin select for channel B, choose 1 of 8 pins for input channel B 7~0: {PD[7:6], PC[3:2], PB[7:6], PA[3:2]}	0x01
0x04	QDEC_MASK	RW	[0]Interrupt mask 1: enable 0: mask	0x00
0x05	QDEC_INT0	RW	[0]Interrupt flag Write 1 to clear	0x00
0x06	QDEC_READ	R	[7:0] dat_o	0x00
0x07	QDEC_DOUBLE0	RW	[0]: Enable double accuracy mode	0x01
0x08	QDEC_COUNT0_RELOAD	RW	[0]: write 1 to load data When load completes it will be 0.	0x00

21 True Random Number Generator (TRNG)

21.1 Model Overview

The True Random Number Generator (TRNG) module contains entropy source and post processing (Deterministic Random Bit Generators, DRBG). The entropy source is designed using Ring Oscillator (RO). The top block diagram of the random number generator is shown below.

Figure 21-1 Module Structure

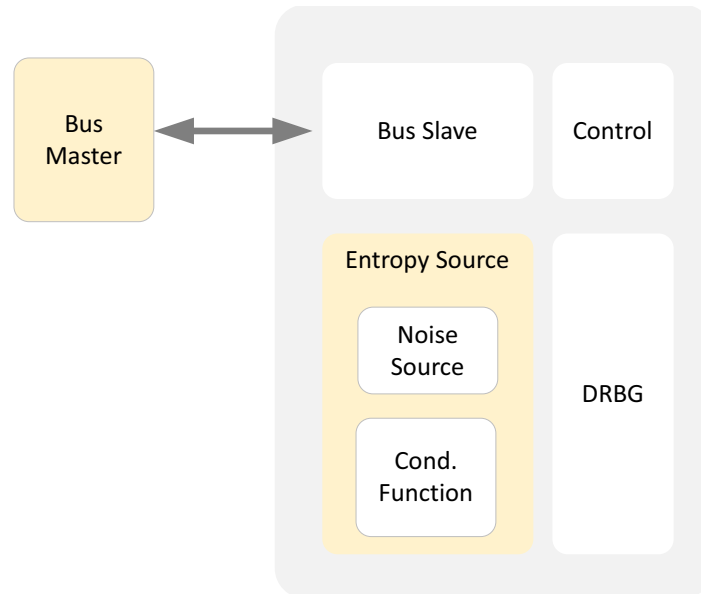

21.2 Interrupt Description

The Random Bit Generator (RBG) module has the following interrupt sources:

- CPU reads RBG_DR without data
- Data valid

The above interrupts can be set by RBG_CR. By default, the data valid interrupt is enabled.

When the RBGEN of RBG_CR is low, the interrupt signal will not be cleared. Therefore, before enabling RBGEN, it is necessary to ensure that there is no previous interrupt signal, otherwise it will affect the next interrupt.

21.2.1 CPU Reads RBG_DR without Data

In order to prevent the CPU from reading the invalid data, the RBG can remind the CPU to read in such a situation when there is no valid random number. In order to avoid the CPU reading the empty data, it is recommended to read the RBG_FIFO_SR first every time to get the random number before the CPU gets data in the current FIFO to avoid invalid data.

The CPU can clear the interrupt by writing 1 to ERERR in RBG_SR. If the write is successful, the interrupt will be cleared. When the above situation occurs again, the interrupt will be valid again.

21.2.2 Data Valid

RBG provides two ways to output data. When the interrupt is enabled, the random number can be read by the way of interrupting. In this design, the data in the corresponding FIFO will only be pulled up after the threshold is reached, thus the CPU can obtain multiple data at once. The threshold can be set by RBG_FIFO_CR. The CPU can clear the interrupt by writing 1 to DRDY of RBG_SR. If the write is successful, the interrupt will be pulled down. The interrupt is pulled high again when the data in the FIFO reaches the threshold again.

It is important to note that the interrupt will only be pulled up when the amount of data in the FIFO reaches the threshold. Therefore, the data in the FIFO exceeds the threshold firstly and then RBG module pulls up the interrupt. When the CPU doesn't obtain data or have obtained data but the amount of data remaining in the FIFO is still larger than the threshold, then clear the interrupt. Although the data in the FIFO is still larger than the threshold, it will not be interrupted.

In addition, the CPU can use the RBG_FIFO_SR register to view the remaining data in the FIFO. It can also use this method to obtain a random number. Check the RBG_FIFO_SR register when the random number is needed and the number of random numbers indicated by the register can be fetched at one time. If the rate at which the CPU handles random numbers is slower than the rate at which RBG random numbers are generated, it is generally not recommended to use interrupt to obtain random numbers.

21.3 Usage Procedure

21.3.1 Normal Operation

Turn off the RBG module first after the CPU works normally, that is to set RBGEN of the RBG_CR to 0. Then it can be configured and write 1 to RBGEN after the configuration is complete to make it work normally.

The CPU can configure RBG module by configuring RBG_CR, RBG_FIFO_CR and other optional configuration registers.

When writing 1 to RBGEN in RBG_CR, the modification of the value of the above register will not affect the RBG. Therefore, when configuring, set the RBGEN in the RBG_CR register after configuring other registers to enable the OSR_RBG module.

TRBG and DRBG can be switched by modifying RBG_RTCCR during the operation to meet different usage environments.

21.3.2 Entropy Source

In this design, the random number generator module uses RO RNG as the entropy source. RO RNG contains modules such as random source and post-processing. RO RNG has four independent RO entropy sources. Each entropy source can choose to use its own RO CLK as the sampling clock or select the system clock as the sampling clock. The selection is determined by the input of I_rbg_sclk_sel, which is high for the system clock and low for the internal RO CLK. All RO enable signals are open at the same time and some of the ROs can be turned on or off by controlling the register.

21.4 Register Description

TRNG related registers are listed in the following table. The base address for the following registers is 0x80101800.

Table 21-1 TRNG Related Register

Offset	Type	Description	Reset Value
0x00	RW	TRNG_CRO [0]: Random bit generator enable. [1]: Each bit states enable for one RO SOURCE0 [2]: Each bit states enable for one RO SOURCE1 [3]: Each bit states enable for one RO SOURCE2 [4]: Each bit states enable for one RO SOURCE3	0x07
0x04	RW	TRNG_RTCCR [0]: Mode select. 0: TRBG without post-processing; 1: TRBG with post-processing	0x00
0x08	R	RBG_SR [0]: Data ready. Data valid indicating bit, 0: random data not ready; 1: random data ready.	0x00
0x0c	R	RBG_DR0, rbg data	0x00
0x0d	R	RBG_DR1, rbg data	0x00
0x0e	R	RBG_DR2, rbg data	0x00
0x0f	R	RBG_DR3, rbg data	0x00
0x10	R	RBG_VERSION0 [3:0]: Sub version number [7:4]: Main version number	0x01
0x12	RO	RBG_VERSION2, PROJECT number low	0x3a
0x13	RO	RBG_VERSION3, PROJECT number high	0xef
0x80	RW	RO_CR1_0 RO enable of RO SOURCE1. Each bit controls one RO. In total, there are 16 ROs in RW RO SOURCE 1.	0xff
0x81	RW	RO_CR1_1 RO enable of RO SOURCE1. Each bit controls one RO. In total, there are 16 ROs in RW RO SOURCE 1.	0xff
0x82	RW	RO_CRO_0 RO enable of RO SOURCE0. Each bit controls one RO. In total, there are 16 ROs in RW RO SOURCE 0.	0xff

Offset	Type	Description	Reset Value
0x83	RW	RO_CRO_1 RO enable of RO SOURCE0. Each bit controls one RO. In total, there are 16 ROs in RW RO SOURCE 0.	0xff
0x84	RW	RO_CR3_0 RO enable of RO SOURCE3. Each bit controls one RO. In total, there are 16 ROs in RW RO SOURCE 3.	0x00
0x85	RW	RO_CR3_1 RO enable of RO SOURCE3. Each bit controls one RO. In total, there are 16 ROs in RW RO SOURCE 3.	0x00
0x86	RW	RO_CR2_0 RO enable of RO SOURCE2. Each bit controls one RO. In total, there are 16 ROs in RW RO SOURCE 2.	0x00
0x87	RW	RO_CR2_1 RO enable of RO SOURCE2. Each bit controls one RO. In total, there are 16 ROs in RW RO SOURCE 2.	0x00
0x88	RW	FSEL [1:0]: RO sampling clock frequency division selection. 00: 4 frequency division, 01: 8 frequency division, 10: 16 frequency division, 11: 32 frequency division.	0x03

FCC Statement

This device complies with part 15 of the FCC Rules. Operation is subject to the following two conditions:

(1) This device may not cause harmful interference, and (2) this device must accept any interference received, including interference that may cause undesired operation.

Any Changes or modifications not expressly approved by the party responsible for compliance could void the user's authority to operate the equipment.

Note: This equipment has been tested and found to comply with the limits for a Class B digital device, pursuant to part 15 of the FCC Rules. These limits are designed to provide reasonable protection against harmful interference in a residential installation. This equipment generates, uses and can radiate radio frequency energy and, if not installed and used in accordance with the instructions, may cause harmful interference to radio communications. However, there is no guarantee that interference will not occur in a particular installation. If this equipment does cause harmful interference to radio or television reception, which can be determined by turning the equipment off and on, the user is encouraged to try to correct the interference by one or more of the following measures:

- Reorient or relocate the receiving antenna.
- Increase the separation between the equipment and receiver.
- Connect the equipment into an outlet on a circuit different from that to which the receiver is connected.
- Consult the dealer or an experienced radio/TV technician for help.

The distance between user and products should be no less than 20cm

