



Telink

EVB User Guide

TL8R8298DK56D

Telink Internal Only

2022-06-22

1. Product introduction

■ 1.1 General introduction

- This document describes the TLSR8298 Universal Starter Kit (hereafter referred to as the Starter Kit). This suite can be used to validate chips and development for example , TLSR8298 offers competitive solution for medical, RFID, and similar types of applications. BT 5.1, allowing easy connectivity with Bluetooth Smart Ready mobile phones, tablets and medical equipment.etc.

■ 1.2 Package Material list

- The order name for the TLSR8298 Universal starter KIT is TLSR8298DK56D-Kit. The materials in the kit are listed here:
 - ▲ 1x TLSR8298DK56D
 - ▲ 1x Burning EVK for 8298 ONLY, Including the Dupont line
 - ▲ 1x USB cable
 - ▲ 1x 2.4G rod antenna

1. Product Introduction - Continued

1.2 Kit Material List - continued



2. Core Board Introduction

■ 2.1 EVB introduction

■ EVB is TLSR8298 developed, the chip has the following new features:

- The TLSR8298 can be applied to Bluetooth low energy applications. Its typical applications include ULP (Ultralow Power) RFID (Radio Frequency Identification) devices, medical disposal Bluetooth LE application, small form factor BLE/2.4G application, etc

■ 核心板有如下特点:

1. • Clock sources: 24 MHz & 32.768 kHz crystals and 24 MHz & 32 kHz embedded RC oscillators
2. • Up to 12 GPIOs (QFN24)/6 GPIOs (WLCSP). All digital IOs can be used as GPIOs.
3. • SPI/I2C/UART with hardware flow control and 7816 protocol support
4. • Swire debug Interface
5. • Up to 3 channels of differential PWM:
6. • 14bit 4/1-channel (only GPIO input) SAR ADC
7. • Temperature sensor

2. Core Board Introduction - Continued

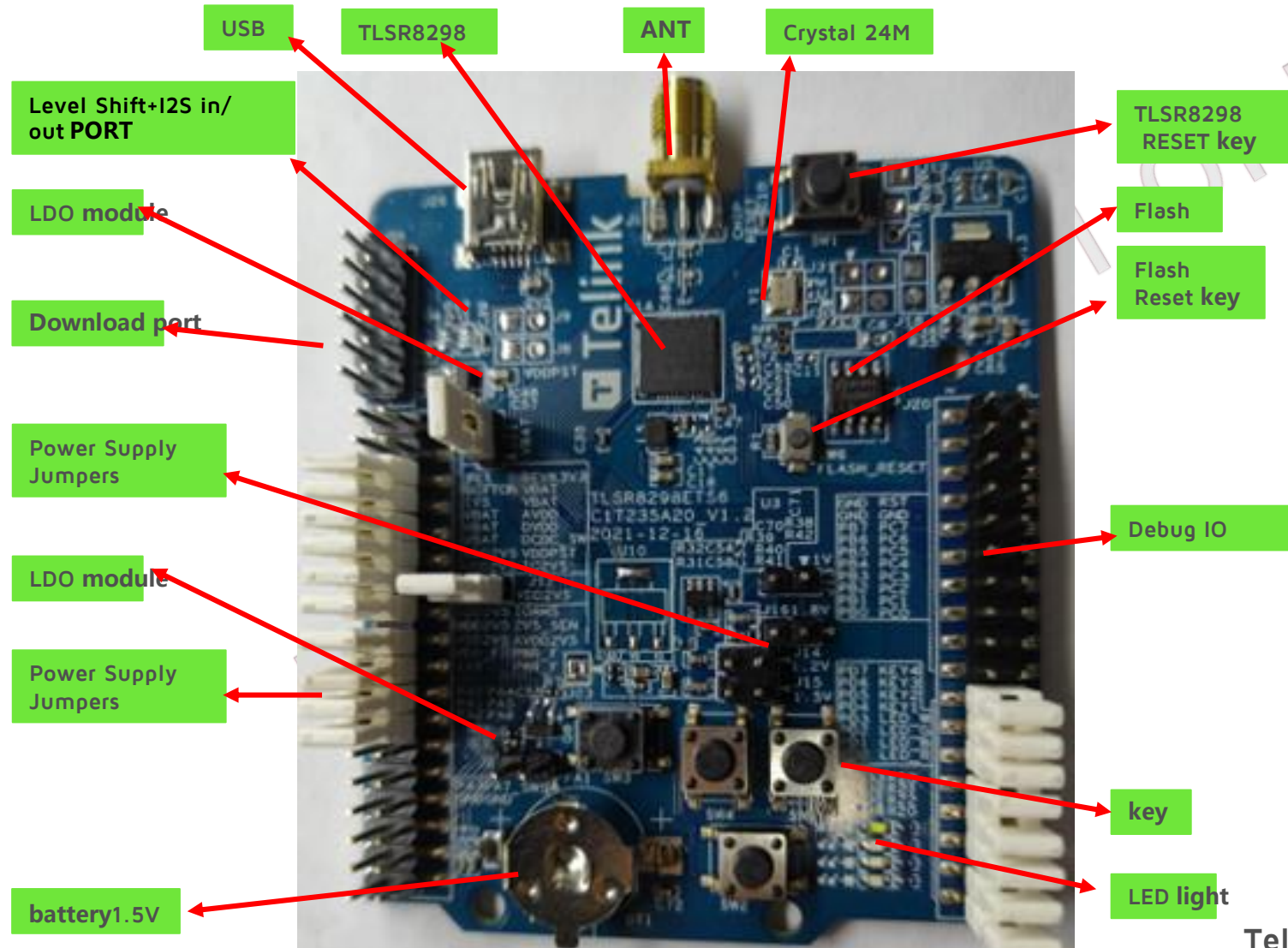

2. Core Board Introduction - Continued

■ 2.1.2 Development board name

- EVB is sold under the name TLSR8298DK56D. The customer submits an order with this name for purchase. EVB has a serial number on the board for version differentiation. The following figure shows the serial number of V1.2. The latest version of EVB is V1.2.

Telink Internal Only

2. Core Board Introduction - Continued

2.1.3 SWS burnprocess port

- The EVB DEBUG interface is on the upper left corner of the development board and on the upper side of the mini USB interface, as shown in the lower left figure. Debug pin, as shown in the lower right figure.

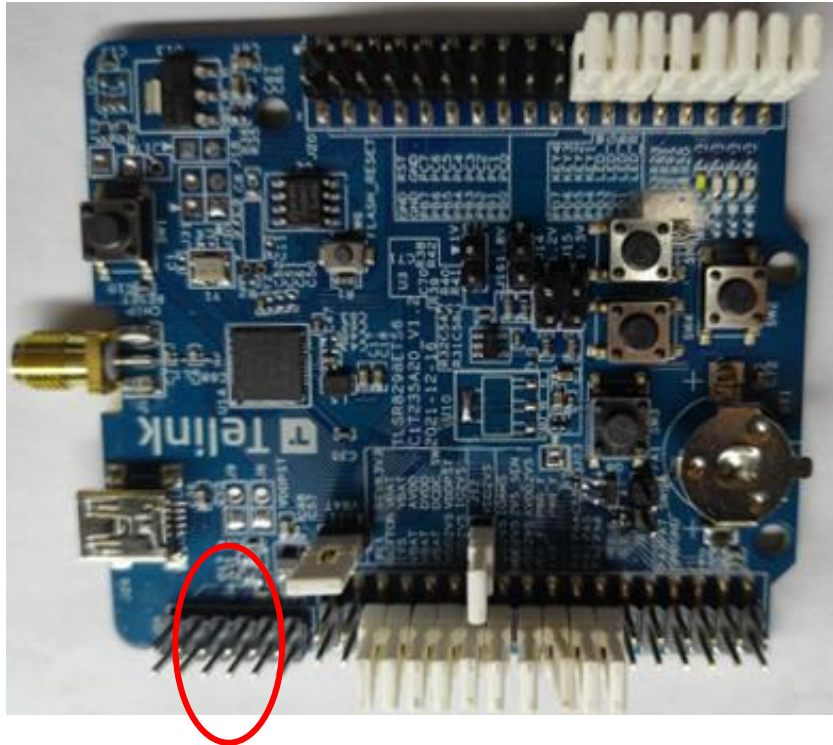

3V3	3V3
SWS	SWS
GND	GND
GND	GND
VBUS	VBUS

2. Core Board Introduction - Continued

2.1.3 SWS burnprocess interface

- SWS burnprocess wiring as shown in the figure.

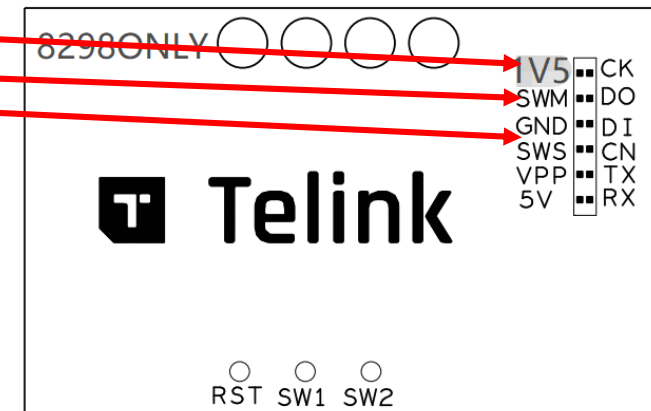
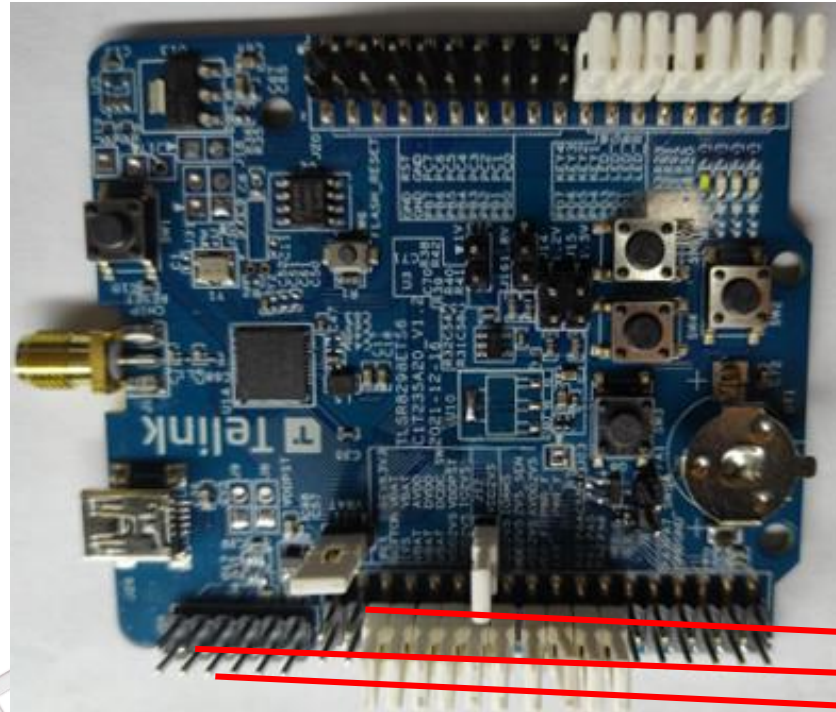

2. Core Board Introduction - Continued

■ 2.1.5 RF port

- The development board RF interface is a 3.5mm SMA plug. Therefore, it can be directly connected to the instrument for RF performance testing, and it can also be connected to the whip antenna for radiation testing.

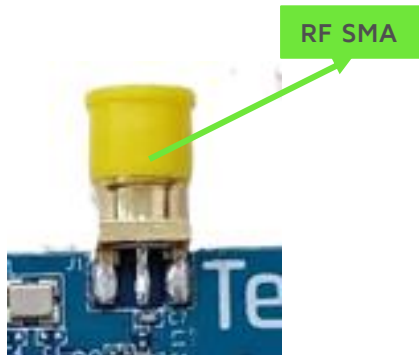

2. Core Board Introduction - Continued

2.1.6 Reset button

- Considering the development of some emergencies, EVB reserved chip reset button.

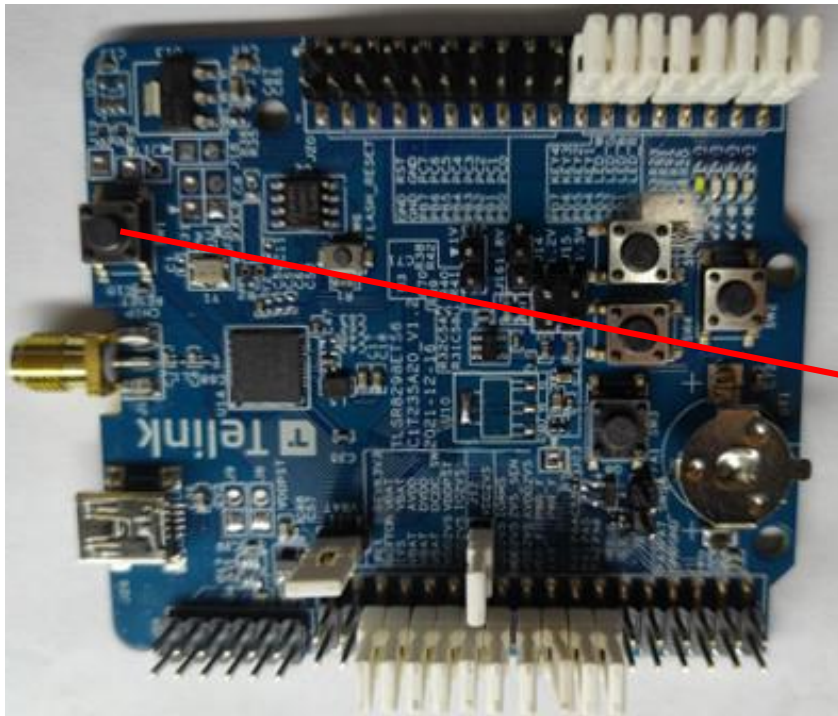

复位按键

2. Core Board Introduction - Continued

2.1.7 Button

- EVB has three buttons reserved, and the software can be customized according to the IO port of the buttons, as shown in the following figure.

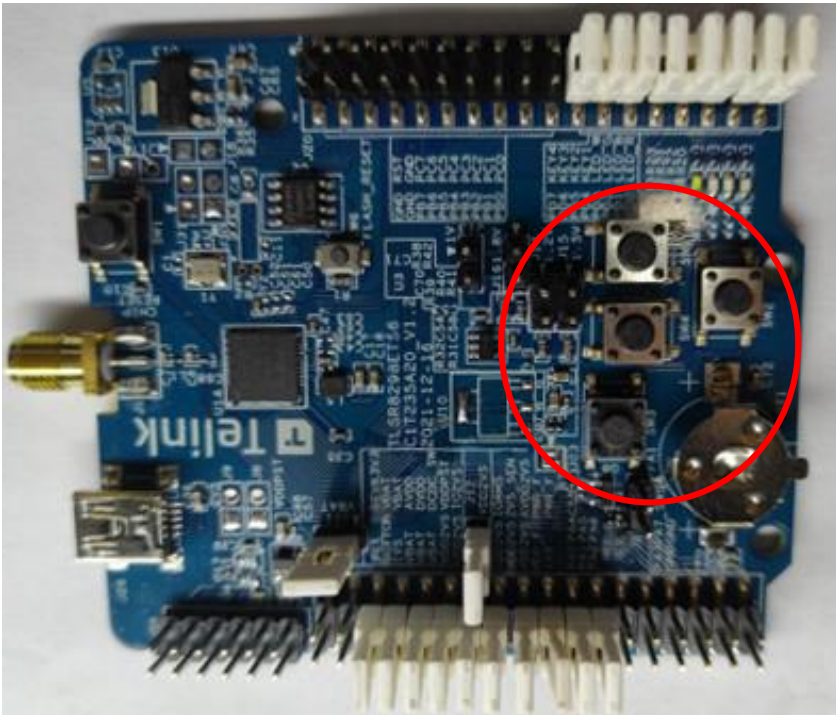

TL_PD7	22	21	TL_Key4
TL_PD6	24	23	TL_Key3
TL_PD5	26	25	TL_Key2
TL_PD4	28	27	TL_Key1
TL_PD3	30	29	LED_W
TL_PD2	32	31	LED_G
TL_PD1	34	33	LED_B
TL_PD0	36	35	LED_R

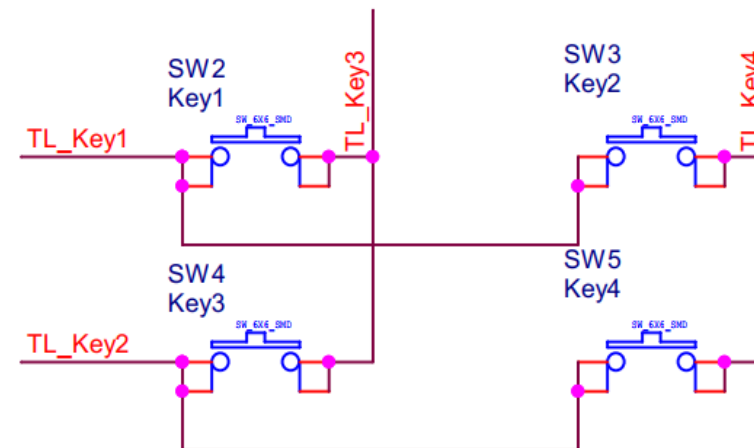

2. Core Board Introduction - Continued

2.1.8 LED light

- One charging indicator and four configurable LED lights are reserved on the EVB, as shown in the following figure.



TL_PD7	22	21	TL_Key4
TL_PD6	24	23	TL_Key3
TL_PD5	26	25	TL_Key2
TL_PD4	28	27	TL_Key1
TL_PD3	30	29	LED_W
TL_PD2	32	31	LED_G
TL_PD1	34	33	LED_B
TL_PD0	36	35	LED_R

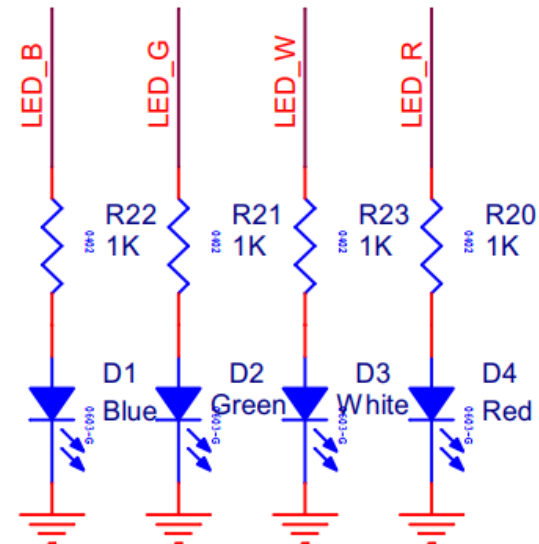

2. Core Board Introduction - Continued

2.1.4 power supply mode

- EVB has three power supply modes, support button battery 1.5V battery power supply, USB 5V voltage power supply and 1V5EVK power supply.
- 1.USB power supply only needs to be connected to the USB interface of the EVB through the USB data cable, as shown in the following figure.

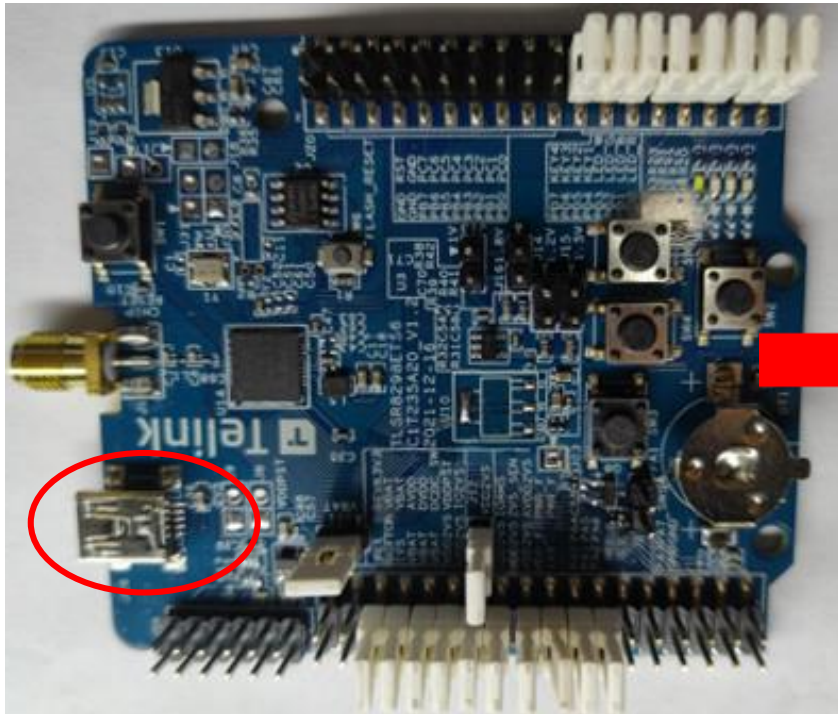

The USB input voltage is 5V

2. Core Board Introduction - Continued

■ 2.1.4 power supply mode

- 2.USB charging only needs to connect the USB interface of the EVB through the USB data cable to power supply, as shown in the following figure.

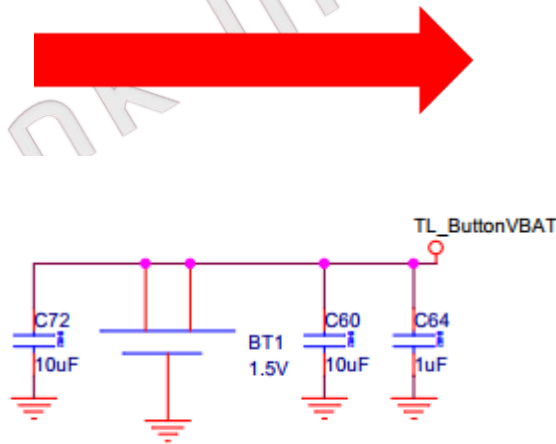

AG13 Button battery power

2. Core Board Introduction - Continued

- 2.1.4 power supply mode
 - 1V5EVK power supply, as shown in the following figure.

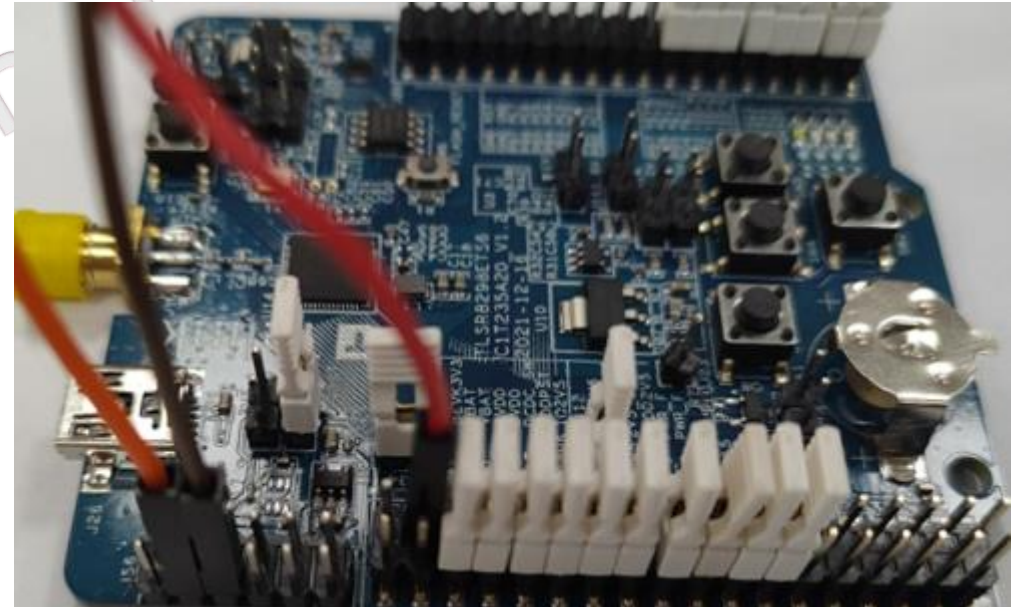

1V5EVK power supply

FCC Statement

FCC standards: FCC CFR Title 47 Part 15 Subpart C Section 15.247

Device is equipped with External antenna(reversed polarity unique antenna port), Antenna gain 2dBi

This device complies with part 15 of the FCC Rules. Operation is subject to the following two conditions:

(1) This device may not cause harmful interference, and (2) this device must accept any interference received, including interference that may cause undesired operation.

Any Changes or modifications not expressly approved by the party responsible for compliance could void the user's authority to operate the equipment.

Note: This equipment has been tested and found to comply with the limits for a Class B digital device, pursuant to part 15 of the FCC Rules. These limits are designed to provide reasonable protection against harmful interference in a residential installation. This equipment generates, uses and can radiate radio frequency energy and, if not installed and used in accordance with the instructions, may cause harmful interference to radio communications. However, there is no guarantee that interference will not occur in a particular installation. If this equipment does cause harmful interference to radio or television reception, which can be determined by turning the equipment off and on, the user is encouraged to try to correct the interference by one or more of the following measures:

- Reorient or relocate the receiving antenna.
- Increase the separation between the equipment and receiver.
- Connect the equipment into an outlet on a circuit different from that to which the receiver is connected.
- Consult the dealer or an experienced radio/TV technician for help.

We will retain control over the final installation of the modular such that compliance of the end product is assured. In such cases, an operating condition on the limit modular approval for the module must be only approved for use when installed in devices produced by a specific manufacturer. If any hardware modify or RF control software modify will be made by host manufacturer, C2PC or new certificate should be apply to get approval, if those change and modification made by host manufacturer not expressly approved by the party responsible for compliance, then it is illegal.

FCC Radiation Exposure Statement

The modular can be installed or integrated in mobile or fix devices . This modular cannot be installed in any portable device if without further certification such as C2PC with SAR. This modular complies with FCC RF radiation exposure limits set forth for an uncontrolled environment. This transmitter must not be co-located or operating in conjunction with any other antenna or transmitter. This modular must be installed and operated with a minimum distance of 20 cm between the radiator and user body.

If the FCC identification number is not visible when the module is installed inside another device, then the outside of the device into which the module is installed must also display a label referring to the enclosed module. This exterior label can use wording such as the following: "Contains Transmitter Module FCC ID: OEOTLSR8298DK56D Or Contains FCC ID: OEOTLSR8298DK56D"

When the module is installed inside another device, the user manual of the host must contain below warning statements;

1. This device complies with Part 15 of the FCC Rules. Operation is subject to the following two conditions:
 - (1) This device may not cause harmful interference;
 - (2) This device must accept any interference received, including interference that may cause undesired operation.

Note: This equipment has been tested and found to comply with the limits for a Class B digital device, pursuant to part 15 of the FCC Rules. These limits are designed to provide reasonable protection against harmful interference in a residential installation. This equipment generates, uses and can radiate radio frequency energy and, if not installed and used in accordance with the instructions, may cause harmful interference to radio communications.

However, there is no guarantee that interference will not occur in a particular installation. If this equipment does cause harmful interference to radio or television reception, which can be determined by turning the equipment off and on, the user is encouraged to try to correct the interference by one or more of the following measures:

- Reorient or relocate the receiving antenna.
- Increase the separation between the equipment and receiver.
- Connect the equipment into an outlet on a circuit different from that to which the receiver is connected.
- Consult the dealer or an experienced radio/TV technician for help.

2. Changes or modifications not expressly approved by the party responsible for compliance could void the user's authority to operate the equipment.

The devices must be installed and used in strict accordance with the manufacturer's instructions as described in the user documentation that comes with the product.

Any company of the host device which install the modular with limit modular approval should perform the test of radiated & conducted emission and spurious emission, etc. according to FCC part 15C : 15.247 and 15.209 & 15.207 ,15B Class B requirement, Only if the test result comply with FCC part 15C : 15.247 and 15.209 & 15.207 ,15B Class B requirement, then the host can be sold legally.