



Shenzhen Certification Technology Service Co., Ltd  
2F, Building B, East Area of Nanchang Second Industrial  
Zone, Gushu 2nd Road, Bao'an District, Shenzhen  
518126, P.R. China.

# TEST REPORT

## FCC ID: OEN-EBOX

**Applicant** : Champion Asia Digital Technology Limited  
**Address** : 4/F,Block B, No. 2 Building , Anle Industrial Park, Hezhou, Xixiang,  
Bao An district, Shenzhen City , P.R. China

### Equipment under Test (EUT):

**Name** : IPTV BOX  
**Model** : CA-EBOX-S12

**Standards** : FCC PART 15, SUBPART C : 2011 (Section 15.247)

**Report No.** : STE120514523

**Date of Test** : June 03-13, 2012

**Date of Issue** : June 15, 2012

<b>Test Result :</b>	<b>PASS *</b>
----------------------	---------------

\* In the configuration tested, the EUT complied with the standards specified above

Authorized Signature

(Mark Zhu)  
General Manager

The manufacture should ensure that all the products in series production are in conformity with the product sample detailed in this report.

If the product in this report is used in any configuration other than that detailed in the report, the manufacturer must ensure the new system complies with all relevant standards. Any mention of Shenzhen Certification Technology Service Co., Ltd. Or test done by Shenzhen Certification Technology Service Co., Ltd. Approvals in connection with, distribution or use of the product described in this report must be approved by Shenzhen Certification Technology Service Co., Ltd. Approvals in writing.

## TABLE OF CONTENT

Description	Page
<b>1 General Information -----</b>	<b>4</b>
1.1 Description of Device (EUT) -----	4
1.2 Description of Test Facility -----	5
<b>2 EMC Equipment List -----</b>	<b>6</b>
<b>3 Test Procedure -----</b>	<b>7</b>
<b>4 Summary of Measurement -----</b>	<b>8</b>
4.1 Summary of test result -----	8
4.2 Test connection -----	8
4.3 Assistant equipment used for test -----	9
4.4 Test mode -----	9
<b>5 Spurious Emission -----</b>	<b>10</b>
5.1 Radiation Emission Limits(15.209) -----	10
5.2 Test Setup -----	10
5.3 Test Procedure -----	12
5.4 Test Equipment Setting For emission test Result -----	12
5.5 Test Condition -----	13
5.6 Test Result -----	13
<b>6 POWER LINE CONDUCTED EMISSION -----</b>	<b>30</b>
6.1 Conducted Emission Limits(15.209&249) -----	30
6.2 Test Setup -----	30
6.3 Test Procedure -----	31
6.4 Test Results -----	31
<b>7 Peak Power -----</b>	<b>36</b>
7.1 Test limit -----	36
7.2 Test Procedure -----	36
7.3 Test Setup -----	36
7.4 Test Results -----	36
<b>8 PEAK POWER SPECTRAL DENSITY -----</b>	<b>44</b>
8.1 Test limit -----	44
8.1.1 Please refer section15.247. -----	44
8.2 Method of measurement -----	44
8.3 Test Setup -----	44
8.4 Test Results -----	45
<b>9 6dB Bandwidth -----</b>	<b>52</b>
9.1 Test limit -----	52
9.2 Method of measurement -----	52
9.3 Test Setup -----	52
9.4 Test Results -----	52
<b>10 Band Edge Check -----</b>	<b>59</b>
10.1 Test limit -----	59
Please refer section15.247 -----	59
10.2 Test Procedure -----	59

---

10.3	Test Setup	59
10.4	Test Result	59
<b>11</b>	<b>Antenna Requirement</b>	<b>76</b>
11.1	Standard Requirement	76
11.2	Antenna Connected Construction	76
11.3	Result	76
<b>12</b>	<b>Photographs of Test Setup</b>	<b>77</b>
<b>13</b>	<b>Photographs of EUT</b>	<b>82</b>

## 1 General Information

### 1.1 Description of Device (EUT)

Trade Name : N/A

EUT : IPTV BOX

Model No. : CA-EBOX-S12

Type of Antenna : Integral Antenna

Antenna Specification : 0dBi

Operation Frequency : 2412~2462MHZ

Channel number : 11  
IEEE 802.11b: DSSS(CCK,DQPSK,DBPSK)

Modulation type : IEEE 802.11g: OFDM(64QAM, 16QAM, QPSK, BPSK)  
IEEE 802.11n :OFDM(64QAM, 16QAM, QPSK, BPSK)

Power Supply : DC 5V from adapter

Adapter : Manufacturer: CHUMMY  
Model: CMW135A-0502000U

Rated PF output Power : 11.84dBm

Applicant : Champion Asia Digital Technology Limited

Address : 4/F,Block B, No. 2 Building , Anle Industrial Park, Hezhou, Xixiang, Bao An district, Shenzhen City , P.R. China

Manufacturer : Champion Asia Digital Technology Limited

Address : 4/F,Block B, No. 2 Building , Anle Industrial Park, Hezhou, Xixiang, Bao An district, Shenzhen City , P.R. China

## 1.2 Description of Test Facility

Shenzhen Certification Technology Service Co.,Ltd.  
2F, Building B, East Area of Nanchang Second Industrial Zone,  
Gushu 2nd Road, Bao'an District, Shenzhen 518126, P.R. China  
FCC Registered No.:197647  
IC Registered No.:8528B

## 2 EMC Equipment List

Equipment	Manufacture	Model No.	Serial No.	Last cal.	Cal Interval
3m Semi-Anechoic	ETS-LINDGREN	N/A	SEL0017	04/06/2012	1Year
Spectrum analyzer	Agilent	E4443A	MY46185649	04/06/2012	1Year
Receiver	R&S	ESCI	100492	04/06/2012	1Year
Receiver	R&S	ESCI	101202	04/06/2012	1Year
Bilog Antenna	Sunol	JB3	A121206	04/06/2012	1Year
Horn Antenna	EMCO	3115	640201028-06	04/06/2012	1Year
Power Meter	Anritsu	ML2487A	6K00001491	02/23/2012	1Year
ETS Horn Antenna	ETS	3160	SEL0076	12/08/2011	1Year
Active Loop Antenna	Beijing Daze	ZN30900A	SEL0097	04/06/2012	1Year
Cable	Resenberger	N/A	No.1	04/06/2012	1Year
Cable	SCHWARZBECK	N/A	No.2	04/06/2012	1Year
Cable	SCHWARZBECK	N/A	No.3	04/06/2012	1Year
Pre-amplifier	R&S	AFS42-00101 800-25-S-42	SEL0081	04/06/2012	1Year
Pre-amplifier	R&S	AFS33-18002650 -30-8P-44	SEL0080	04/06/2012	1Year

### 3 Test Procedure

**POWER LINE CONDUCTED INTERFERENCE:** The test procedure used was ANSI Standard C63.4-2003 using a 50  $\mu$  H LISN. Both Lines were observed. The bandwidth of the receiver was 10kHz with an appropriate sweep speed. The ambient temperature of the EUT was 25°C with a humidity of 58%.

**RADIATION INTERFERENCE:** The test procedure used was ANSI Standard C63.4-2003 using a ANRITSU spectrum analyzer with a pre-selector. The analyzer was calibrated in dB above a micro volt at the output of the antenna. The resolution bandwidth was 100kHz and the video bandwidth was 300 kHz up to 1 GHz and 1 MHz with a video BW of 3MHz above 1 GHz. The ambient temperature of the EUT was 25°C with a humidity of 58%.

**FORMULA OF CONVERSION FACTORS:** The Field Strength at 3m was established by adding the meter reading of the spectrum analyzer (which is set to read in units of dBuV) to the antenna correction factor supplied by the antenna manufacturer and cable loss. The antenna correction factors and cable loss are stated in terms of dB. The gain of the Pre-selector was accounted for in the Spectrum Analyzer Meter Reading.

Example:

Freq (MHz) METER READING + ACF + CABLE = FS

33.20 dBuV + 10.36 dB + 0.9 dB= 44.46 dBuV/m @ 3m

ANSI STANDARD C63.4-2003 10.1.7 MEASUREMENT PROCEDURES: The EUT was placed on a table 80 cm high and with dimensions of 1m by 1.5m. The EUT was placed in the center of the table (1.5m side). The table used for radiated measurements is capable of continuous rotation. When an emission was found, the table was rotated to produce the maximum signal strength. At this point, the antenna was raised and lowered from 1m to 4m. The antenna was placed in both the horizontal and vertical planes. The situation was similar for the conducted measurement except that the table did not rotate. The EUT was setup as described in ANSI Standard C63.4-2003 10.1.7 with the EUT 40 cm from the vertical ground wall.

## 4 Summary of Measurement

### 4.1 Summary of test result

Test Item	Test Requirement	Standards Paragraph	Result
Spurious Emission	FCC PART 15 : 2011	Section 15.247&15.209	Compliance
Conduction Emission	FCC PART 15: 2011	Section 15.207	Compliance
6dB Bandwidth Test	FCC PART 15:2011	Section 15.247	Compliance
Peak Power	FCC PART 15:2011	Section 15.247	Compliance
Power Density	FCC PART 15:2011	Section 15.247	Compliance
Band Edge	FCC PART 15:2011	Section 15.247	Compliance
Antenna Requirement	FCC PART 15 : 2011	Section 15.203	Compliance

Note: The EUT has been tested as an independent unit. And Continual Transmitting in maximum power (The adapter be used during Test)

### 4.2 Test connection

For TX mode:

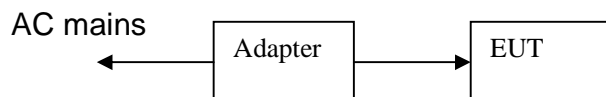

For transmitter data mode:

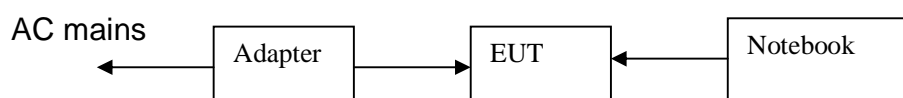



### 4.3 Assistant equipment used for test

Description	:	Notebook
Manufacturer	:	acer
Model No.	:	4552G

### 4.4 Test mode

Tested mode, channel, and data rate information			
Mode	data rate (Mbps)(see Note)	Channel	Frequency (MHz)
IEEE 802.11b	11	Low :CH1	2412
	11	Middle: CH6	2437
	11	High: CH11	2462
IEEE 802.11g	6	Low :CH1	2412
	6	Middle: CH6	2437
	6	High: CH11	2462
IEEE 802.11n/HT20	6.5	Low :CH1	2412
	6.5	Middle: CH6	2437
	6.5	High: CH11	2462
IEEE 802.11n/HT40	13.5	Low :CH3	2422
	13.5	Middle:CH6	2437
	13.5	High:CH9	2452

Note: According exploratory test, EUT will have maximum output power in those data rate. so those data rate were used for all test.

## 5 Spurious Emission

### 5.1 Radiation Emission Limits(15.209)

Frequencies (MHz)	Field Strength (micorvolts/meter)	Measurement Distance (meters)
0.009~0.490	2400/F(KHz)	300
0.490~1.705	24000/F(KHz)	30
1.705~30.0	30	30
30~88	100	3
88~216	150	3
216~960	200	3
Above 960	500	3

Harmonic emissions limits comply with below 54 dBuV/m at 3m. Other emissions radiated outside of the specified frequency bands, except for harmonics, shall be attenuated by at least 50 dB below the level of the fundamental or comply with the radiated emissions limits specified in section 15.209(a) limit in the table below has to be followed.

**NOTE:**

- a) The tighter limit applies at the band edges.
- b) Emission Level(dB uV/m)=20log Emission Level(Uv/m)

### 5.2 Test Setup

See the next page

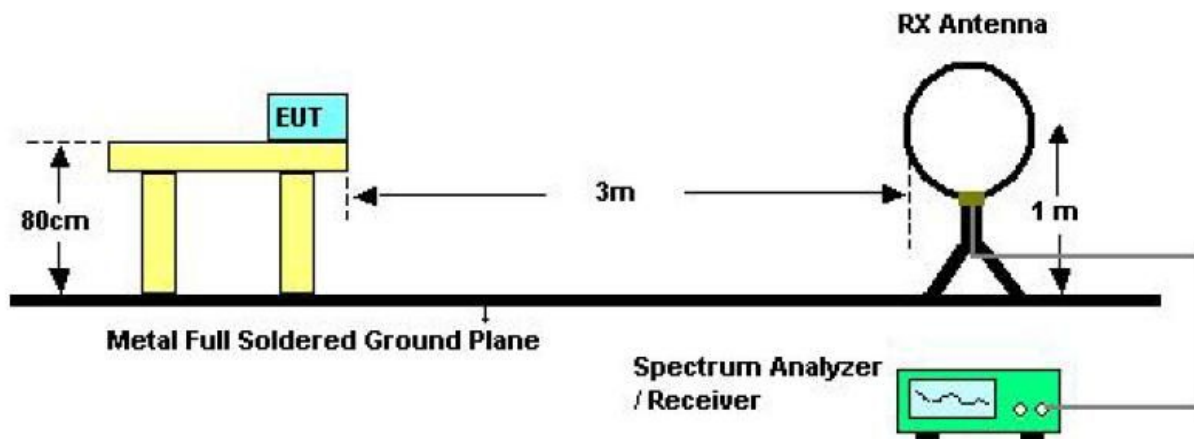

Below 30MHZ Test Setup

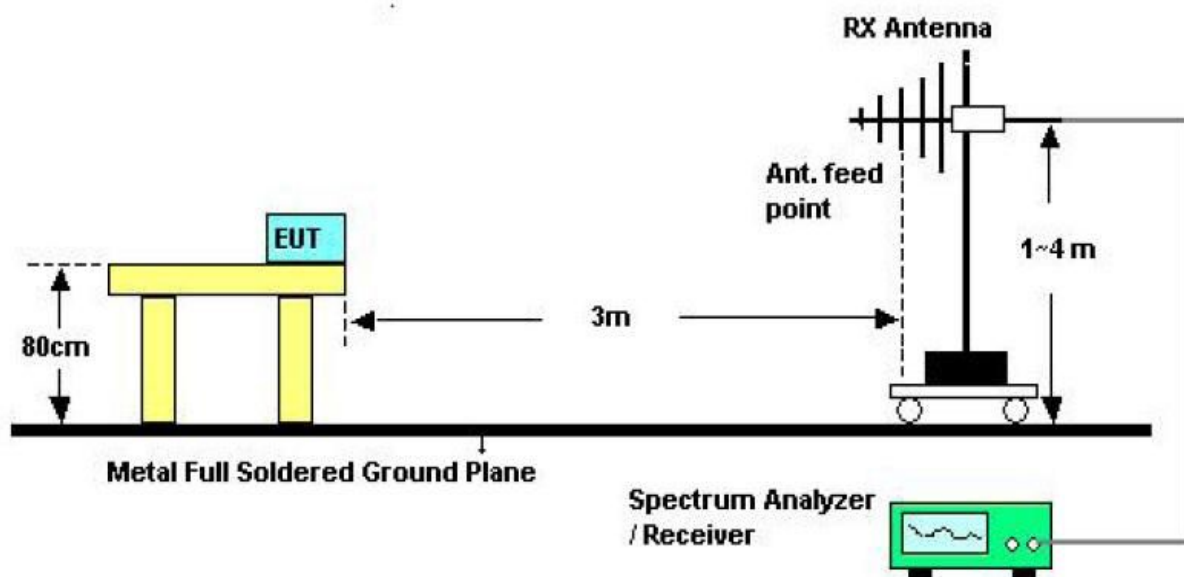

Above 30MHZ Test Setup

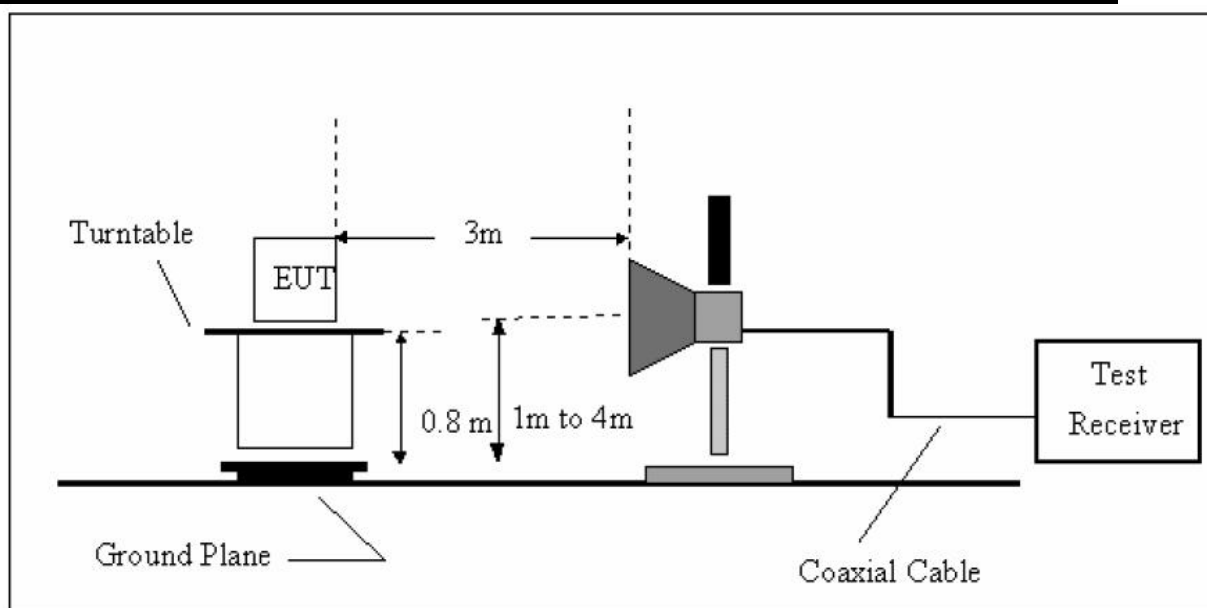

Above 1GHZ Test Setup

### 5.3 Test Procedure

- a) The measuring distance of 3m shall be used for measurements at frequency up to 1GHZ and above 1GHZ, The EUT was placed on a rotating 0.8 m high above ground, The table was rotated 360 degrees to determine the position of the highest radiation
- b) The Test antenna shall vary between 1m and 4m,Both Horizontal and Vertical antenna are set of make measurement.
- c) The initial step in collecting conducted emission data is a spectrum analyzer Peak detector mode pre-scanning the measurement frequency range. Significant Peaks are then marked. and then Qusia Peak Detector mode premeasured
- d) If Peak value comply with QP limit Below 1GHZ.The EUT deemed to comply with QP limit. But the Peak value and average value both need to comply with applicable limit above 1GHZ.
- e) For the actual test configuration, please see the test setup photo.

### 5.4 Test Equipment Setting For emission test Result

9KHZ~150KHZ	RBW 200HZ	VBW1KHZ
150KHZ~30MHZ	RBW 9KHZ	VBW 30KHZ
30MHZ~1GHZ	RBW 120KHZ	VBW 300KHZ
Above 1GHZ	RBW 1MHZ	VBW 3MHZ

#### 5.5 Test Condition

Continual Transmitting in maximum power.

#### 5.6 Test Result

We have scanned the 5th harmonic from 9KHz to the EUT.

Detailed information please see the following page.

From 9KHz to 30MHz: Conclusion: PASS

Note: The amplitude of spurious emissions which are attenuated by more than 20dB below the permissible value has no need to be reported.

Report No.:STE120514523  
 From 30MHz to 1GHz



Shenzhen Certification Technology Service Co., Ltd  
 2F, Building B, East Area of Nanchang Second Industrial Zone,  
 Gushu 2nd Road, Bao'an District, Shenzhen 518126, P.R. China  
 Tel: 4006786199 FAX: +86-755-26736857  
 Website: <http://www.cessz.com> Email: [Service@cessz.com](mailto:Service@cessz.com)

Data: 1 File: E:\REPORT DATA\Asia\RE设置.EM6 (2) Date: 2012-06-10 Time: 09:34:59

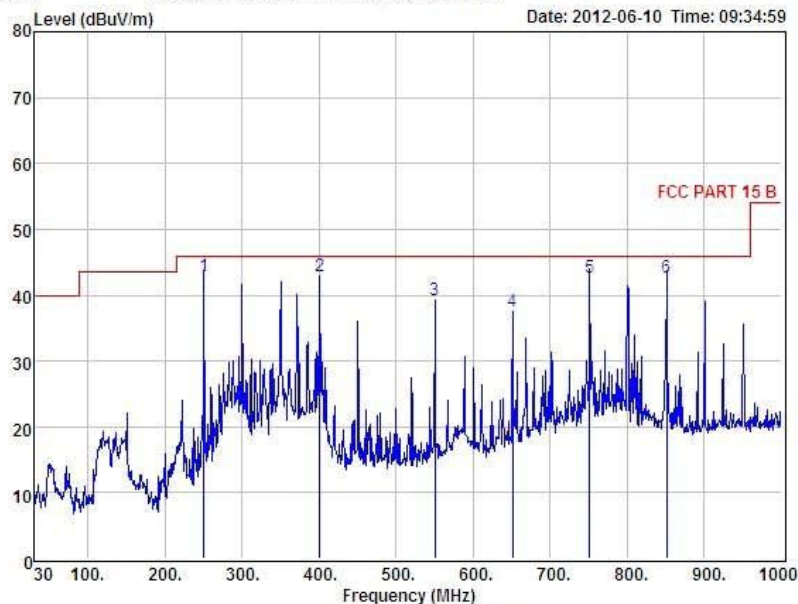

Condition : FCC PART 15 B 3m POL: HORIZONTAL  
 EUI : IPTV BOX  
 Model No. : CA-EBOX-S12  
 Test Mode : Working  
 Power : AC 120V/60Hz  
 Test Engineer : Store  
 Remark :

Item	Freq MHz	Read Level dBuV	Antenna Factor dB	Preamp Factor dB	Cable Loss dB	Level dBuV	Limit dBuV	Margin dBuV	Remark
1	250.19	60.68	11.57	31.11	1.67	42.81	46.00	-3.19	QP
2	400.54	57.18	14.74	31.43	2.47	42.96	46.00	-3.04	QP
3	549.92	50.57	17.39	31.71	3.10	39.35	46.00	-6.65	QP
4	650.80	47.02	19.11	31.79	3.30	37.64	46.00	-8.36	QP
5	750.71	50.53	20.27	31.68	3.50	42.62	46.00	-3.38	QP
6	850.62	49.66	21.06	31.71	3.70	42.71	46.00	-3.29	QP



Shenzhen Certification Technology Service Co., Ltd  
 2F, Building B, East Area of Nanchang Second Industrial Zone,  
 Gushu 2nd Road, Bao'an District, Shenzhen 518126, P.R. China  
 Tel: 4006786199 FAX: +86-755-26736857  
 Website: <http://www.cessz.com> Email: [Service@cessz.com](mailto:Service@cessz.com)

Data: 2 File: E:\REPORT DATA\Asia\RE设置.EM6 (2) Date: 2012-06-10 Time: 09:38:24

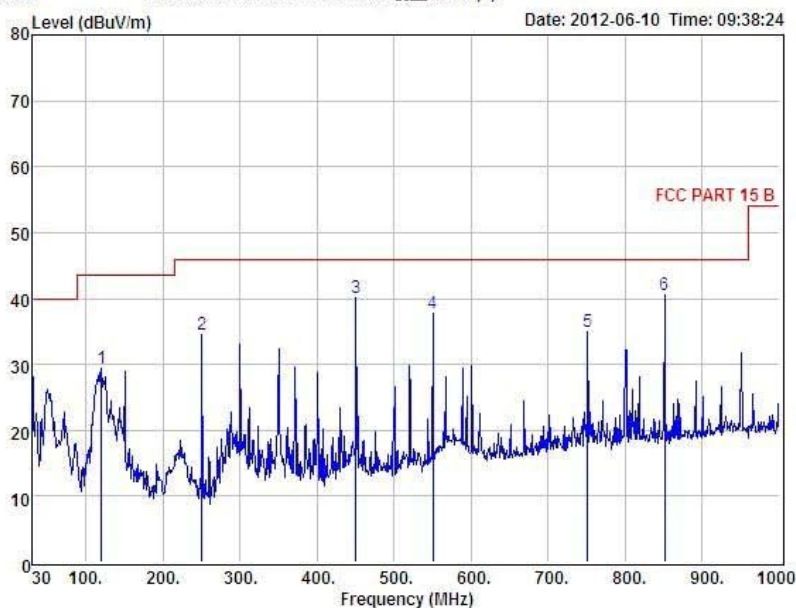

Condition : FCC PART 15 B 3m POL: VERTICAL  
 EUT : IPTV BOX  
 Model No. : CA-EBOX-S12  
 Test Mode : Working  
 Power : AC 120V/60Hz  
 Test Engineer : Store  
 Remark :

Item	Freq MHz	Read Level dBUV	Antenna Factor dB	Preamp Factor dB	Cable Lose dB	Level dBUV	Limit dBUV	Margin dBUV	Remark
1	120.21	47.12	12.24	30.88	0.97	29.45	43.50	-14.05	QP
2	250.19	52.38	11.57	31.11	1.67	34.51	46.00	-11.49	QP
3	450.01	52.78	15.97	31.48	2.73	40.00	46.00	-6.00	QP
4	549.92	49.05	17.39	31.71	3.10	37.83	46.00	-8.17	QP
5	750.71	42.82	20.27	31.68	3.50	34.91	46.00	-11.09	QP
6	850.62	47.38	21.06	31.71	3.70	40.43	46.00	-5.57	QP



Shenzhen Certification Technology Service Co., Ltd  
 2F, Building B, East Area of Nanchang Second Industrial Zone,  
 Gushu 2nd Road, Bao'an District, Shenzhen 518126, P.R. China  
 Tel: 4006786199 FAX: +86-755-26736857  
 Website: <http://www.cessz.com> Email: [Service@cessz.com](mailto:Service@cessz.com)

Data: 7 File: E:\REPORT DATA\C\Champion\STE120514523.EM6 (8) Date: 2012-07-17 Time: 14:16:54

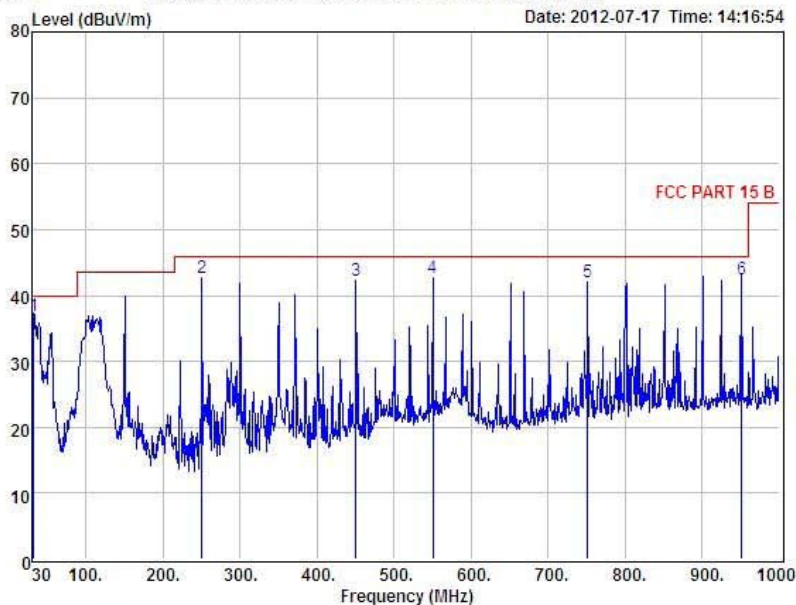

Condition : FCC PART 15 B 3m POL: VERTICAL  
 EUT : IPTV BOX  
 Model No : CA-EBOX-S12  
 Test Mode : Data Transmission  
 Power : AC 120V/60Hz  
 Test Engineer : Store  
 Remark :

Item	Freq MHz	Read Level dBuV	Antenna Factor dB	Preamp Factor dB	Cable Lose dB	Level dBuV	Limit dBuV	Margin dBuV	Remark
1	31.94	50.67	13.28	27.51	0.51	36.95	40.00	-3.05	QP
2	250.19	56.54	11.57	27.11	1.67	42.67	46.00	-3.33	QP
3	450.01	51.06	15.97	27.48	2.73	42.28	46.00	-3.72	QP
4	549.92	49.99	17.39	27.71	3.10	42.77	46.00	-3.23	QP
5	750.71	45.90	20.27	27.68	3.50	41.99	46.00	-4.01	QP
6	950.53	44.07	22.14	27.62	3.90	42.49	46.00	-3.51	QP





Shenzhen Certification Technology Service Co., Ltd  
 2F, Building B, East Area of Nanchang Second Industrial Zone,  
 Gushu 2nd Road, Bao'an District, Shenzhen 518126, P.R. China  
 Tel: 4006786199 FAX: +86-755-26736857  
 Website: <http://www.cessz.com> Email: [Service@cessz.com](mailto:Service@cessz.com)

Data: 8 File: E:\REPORT DATA\C\Champion\STE120514523.EM6 (8) Date: 2012-07-17 Time: 14:18:55

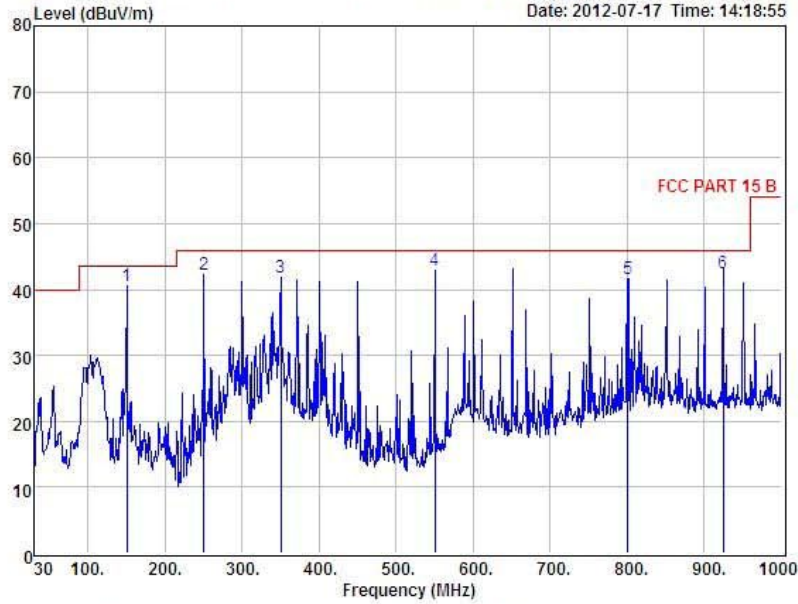

Condition : FCC PART 15 B 3m POL: HORIZONTAL  
 EUT : IPTV BOX  
 Model No : CA-EBOX-S12  
 Test Mode : Data Transmission  
 Power : AC 120V/60Hz  
 Test Engineer : Store  
 Remark :

Item	Freq MHz	Read Level dBUV	Antenna Factor dB	Preamp Factor dB	Cable Loss dB	Level dBUV	Limit dBUV	Margin dBUV	Remark
1	150.28	52.09	14.16	26.91	1.13	40.47	43.50	-3.03	QP
2	250.19	56.07	11.57	27.11	1.67	42.20	46.00	-3.80	QP
3	350.10	53.15	13.83	27.27	2.20	41.91	46.00	-4.09	QP
4	549.92	50.02	17.39	27.71	3.10	42.80	46.00	-3.20	QP
5	800.18	45.00	20.70	27.65	3.60	41.65	46.00	-4.35	QP
6	924.34	44.28	21.97	27.63	3.85	42.47	46.00	-3.53	QP

<b>EUT</b>	IPTV BOX	<b>Model Name</b>	CA-EBOX-S12
<b>Temperature</b>	26°C	<b>Relative Humidity</b>	56%
<b>Pressure</b>	960hPa	<b>Test voltage</b>	DC 5V supply by Adapter
<b>Test Mode</b>	TX Low		

Freq. (MHz)	Ant. Pol H/V	Peak Reading (dBuV)	AV Reading (dBuV)	Ant. / CL CF (dB)	Actual Fs		Peak Limit (dBuV/m)	AV Limit (dBuV/m)	Margin (dB)	Remark
					Peak (dBuV/m)	AV (dBuV/m)				
1436	V	48.45	---	-10.29	38.16	---	74.00	54.00	-15.84	Peak
1724	V	48.60	---	-9.53	39.07	---	74.00	54.00	-14.93	Peak
1843	V	51.08	---	-9.16	41.92	---	74.00	54.00	-12.08	Peak
4823	V	41.61	---	0.64	42.25	---	74.00	54.00	-11.75	Peak
N/A										

<b>EUT</b>	IPTV BOX	<b>Model Name</b>	CA-EBOX-S12
<b>Temperature</b>	26°C	<b>Relative Humidity</b>	56%
<b>Pressure</b>	960hPa	<b>Test voltage</b>	DC 5V supply by Adapter
<b>Test Mode</b>	TX Low		

Freq. (MHz)	Ant. Pol H/V	Peak Reading (dBuV)	AV Reading (dBuV)	Ant. / CL CF (dB)	Actual Fs		Peak Limit (dBuV/m)	AV Limit (dBuV/m)	Margin (dB)	Remark
					Peak (dBuV/m)	AV (dBuV/m)				
1165	H	49.77	---	-11.73	38.04	---	74.00	54.00	-15.96	Peak
2128	H	46.12	---	-8.36	37.76	---	74.00	54.00	-16.24	Peak
3047	H	47.50	---	-5.81	41.69	---	74.00	54.00	-12.31	Peak
4823	H	41.62	---	0.64	42.26	---	74.00	54.00	-11.74	Peak
N/A										

**Notes:** AV Means AV detector test data, Peak Means Peak detector test data.  
Emissions attenuated more than 20 dB below the permissible value are not reported.

<b>EUT</b>	IPTV BOX	<b>Model Name</b>	CA-EBOX-S12
<b>Temperature</b>	26°C	<b>Relative Humidity</b>	56%
<b>Pressure</b>	960hPa	<b>Test voltage</b>	DC 5V supply by Adapter
<b>Test Mode</b>	TX Mid		

Freq. (MHz)	Ant. Pol H/V	Peak Reading (dBuV)	AV Reading (dBuV)	Ant. / CL CF (dB)	Actual Fs		Peak Limit (dBuV/m)	AV Limit (dBuV/m)	Margin (dB)	Remark
					Peak (dBuV/m)	AV (dBuV/m)				
1437	V	47.86	---	-10.29	37.57	---	74.00	54.00	-16.43	Peak
1853	V	47.15	---	-9.04	38.11	---	74.00	54.00	-15.89	Peak
2962	V	49.09	---	-5.95	43.14	---	74.00	54.00	-10.86	Peak
4871	V	43.07	---	0.76	43.83	---	74.00	54.00	-10.17	Peak

<b>EUT</b>	IPTV BOX	<b>Model Name</b>	CA-EBOX-S12
<b>Temperature</b>	26°C	<b>Relative Humidity</b>	56%
<b>Pressure</b>	960hPa	<b>Test voltage</b>	DC 5V supply by Adapter
<b>Test Mode</b>	TX Mid		

Freq. (MHz)	Ant. Pol H/V	Peak Reading (dBuV)	AV Reading (dBuV)	Ant. / CL CF (dB)	Actual Fs		Peak Limit (dBuV/m)	AV Limit (dBuV/m)	Margin (dB)	Remark
					Peak (dBuV/m)	AV (dBuV/m)				
1356	H	48.70	---	-10.43	38.27	---	74.00	54.00	-15.73	Peak
1729	H	47.29	---	-9.53	37.76	---	74.00	54.00	-16.24	Peak
3463	H	47.08	---	-4.95	42.13	---	74.00	54.00	-11.87	Peak
4871	H	42.29	---	0.76	43.05	---	74.00	54.00	-10.95	Peak

**Notes:** AV Means AV detector test data, Peak Means Peak detector test data.  
Emissions attenuated more than 20 dB below the permissible value are not reported.

<b>EUT</b>	IPTV BOX	<b>Model Name</b>	CA-EBOX-S12
<b>Temperature</b>	26°C	<b>Relative Humidity</b>	56%
<b>Pressure</b>	960hPa	<b>Test voltage</b>	DC 5V supply by Adapter
<b>Test Mode</b>	TX High		

Freq. (MHz)	Ant. Pol H/V	Peak Reading (dBuV)	AV Reading (dBuV)	Ant. / CL CF (dB)	Actual Fs		Peak Limit (dBuV/m)	AV Limit (dBuV/m)	Margin (dB)	Remark
					Peak (dBuV/m)	AV (dBuV/m)				
1162	V	52.47	---	-11.73	40.74	---	74.00	54.00	-13.26	Peak
1937	V	48.33	---	-8.86	39.47	---	74.00	54.00	-14.53	Peak
3053	V	48.56	---	-5.74	42.82	---	74.00	54.00	-11.18	Peak
4922	V	41.78	---	0.87	42.65	---	74.00	54.00	-11.35	Peak

<b>EUT</b>	IPTV BOX	<b>Model Name</b>	CA-EBOX-S12
<b>Temperature</b>	26°C	<b>Relative Humidity</b>	56%
<b>Pressure</b>	960hPa	<b>Test voltage</b>	DC 5V supply by Adapter
<b>Test Mode</b>	TX High		

Freq. (MHz)	Ant. Pol H/V	Peak Reading (dBuV)	AV Reading (dBuV)	Ant. / CL CF (dB)	Actual Fs		Peak Limit (dBuV/m)	AV Limit (dBuV/m)	Margin (dB)	Remark
					Peak (dBuV/m)	AV (dBuV/m)				
1943	H	47.57	---	-8.86	38.71	---	74.00	54.00	-15.29	Peak
3156	H	43.04	---	-5.52	37.52	---	74.00	54.00	-16.48	Peak
3682	H	48.25	---	-4.38	43.87	---	74.00	54.00	-10.13	Peak
4922	H	41.57	---	0.87	42.44	---	74.00	54.00	-11.56	Peak

**Notes:** AV Means AV detector test data, Peak Means Peak detector test data.  
Emissions attenuated more than 20 dB below the permissible value are not reported.

IEEE 802.11 g:

<b>EUT</b>	IPTV BOX	<b>Model Name</b>	CA-EBOX-S12
<b>Temperature</b>	26°C	<b>Relative Humidity</b>	56%
<b>Pressure</b>	960hPa	<b>Test voltage</b>	DC 5V supply by Adapter
<b>Test Mode</b>	TX Low		

Freq. (MHz)	Ant. Pol H/V	Peak Reading (dBuV)	AV Reading (dBuV)	Ant. / CL CF (dB)	Actual Fs		Peak Limit (dBuV/m)	AV Limit (dBuV/m)	Margin (dB)	Remark
					Peak (dBuV/m)	AV (dBuV/m)				
1462	V	48.79	---	-10.27	38.52	---	74.00	54.00	-15.48	Peak
1869	V	46.77	---	-9.04	37.73	---	74.00	54.00	-16.27	Peak
2057	V	51.16	---	-8.49	42.67	---	74.00	54.00	-11.33	Peak
4823	V	42.77	---	0.64	43.41	---	74.00	54.00	-10.59	Peak
N/A										

<b>EUT</b>	IPTV BOX	<b>Model Name</b>	CA-EBOX-S12
<b>Temperature</b>	26°C	<b>Relative Humidity</b>	56%
<b>Pressure</b>	960hPa	<b>Test voltage</b>	DC 5V supply by Adapter
<b>Test Mode</b>	TX Low		

Freq. (MHz)	Ant. Pol H/V	Peak Reading (dBuV)	AV Reading (dBuV)	Ant. / CL CF (dB)	Actual Fs		Peak Limit (dBuV/m)	AV Limit (dBuV/m)	Margin (dB)	Remark
					Peak (dBuV/m)	AV (dBuV/m)				
1371	H	49.46	---	-10.43	39.03	---	74.00	54.00	-14.97	Peak
2854	H	43.63	---	-5.87	37.76	---	74.00	54.00	-16.24	Peak
2985	H	48.10	---	-5.86	42.24	---	74.00	54.00	-11.76	Peak
4823	H	42.78	---	0.64	43.42	---	74.00	54.00	-10.58	Peak
N/A										

**Notes:** AV Means AV detector test data, Peak Means Peak detector test data.  
Emissions attenuated more than 20 dB below the permissible value are not reported.

<b>EUT</b>	IPTV BOX	<b>Model Name</b>	CA-EBOX-S12
<b>Temperature</b>	26°C	<b>Relative Humidity</b>	56%
<b>Pressure</b>	960hPa	<b>Test voltage</b>	DC 5V supply by Adapter
<b>Test Mode</b>	TX Mid		

Freq. (MHz)	Ant. Pol H/V	Peak Reading (dBuV)	AV Reading (dBuV)	Ant. / CL CF (dB)	Actual Fs		Peak Limit (dBuV/m)	AV Limit (dBuV/m)	Margin (dB)	Remark
					Peak (dBuV/m)	AV (dBuV/m)				
1464	V	47.85	---	-10.27	37.58	---	74.00	54.00	-16.42	Peak
1728	V	48.68	---	-9.53	39.15	---	74.00	54.00	-14.85	Peak
1940	V	49.14	---	-8.86	40.28	---	74.00	54.00	-13.72	Peak
4871	V	41.71	---	0.76	42.47	---	74.00	54.00	-11.53	Peak

<b>EUT</b>	IPTV BOX	<b>Model Name</b>	CA-EBOX-S12
<b>Temperature</b>	26°C	<b>Relative Humidity</b>	56%
<b>Pressure</b>	960hPa	<b>Test voltage</b>	DC 5V supply by Adapter
<b>Test Mode</b>	TX Mid		

Freq. (MHz)	Ant. Pol H/V	Peak Reading (dBuV)	AV Reading (dBuV)	Ant. / CL CF (dB)	Actual Fs		Peak Limit (dBuV/m)	AV Limit (dBuV/m)	Margin (dB)	Remark
					Peak (dBuV/m)	AV (dBuV/m)				
1385	H	49.79	---	-10.43	39.36	---	74.00	54.00	-14.64	Peak
1621	H	47.02	---	-9.84	37.18	---	74.00	54.00	-16.82	Peak
3736	H	46.87	---	-4.24	42.63	---	74.00	54.00	-11.37	Peak
4871	H	41.18	---	0.76	41.94	---	74.00	54.00	-12.06	Peak

**Notes:** AV Means AV detector test data, Peak Means Peak detector test data.  
Emissions attenuated more than 20 dB below the permissible value are not reported.

<b>EUT</b>	IPTV BOX	<b>Model Name</b>	CA-EBOX-S12
<b>Temperature</b>	26°C	<b>Relative Humidity</b>	56%
<b>Pressure</b>	960hPa	<b>Test voltage</b>	DC 5V supply by Adapter
<b>Test Mode</b>	TX High		

Freq. (MHz)	Ant. Pol H/V	Peak Reading (dBuV)	AV Reading (dBuV)	Ant. / CL CF (dB)	Actual Fs		Peak Limit (dBuV/m)	AV Limit (dBuV/m)	Margin (dB)	Remark
					Peak (dBuV/m)	AV (dBuV/m)				
1488	V	49.70	---	-10.27	39.43	---	74.00	54.00	-14.57	Peak
2953	V	46.04	---	-5.86	40.18	---	74.00	54.00	-13.82	Peak
3761	V	47.55	---	-4.07	43.48	---	74.00	54.00	-10.52	Peak
4922	V	41.41	---	0.87	42.28	---	74.00	54.00	-11.72	Peak

<b>EUT</b>	IPTV BOX	<b>Model Name</b>	CA-EBOX-S12
<b>Temperature</b>	26°C	<b>Relative Humidity</b>	56%
<b>Pressure</b>	960hPa	<b>Test voltage</b>	DC 5V supply by Adapter
<b>Test Mode</b>	TX High		

Freq. (MHz)	Ant. Pol H/V	Peak Reading (dBuV)	AV Reading (dBuV)	Ant. / CL CF (dB)	Actual Fs		Peak Limit (dBuV/m)	AV Limit (dBuV/m)	Margin (dB)	Remark
					Peak (dBuV/m)	AV (dBuV/m)				
1859	H	47.72	---	-9.04	38.68	---	74.00	54.00	-15.32	Peak
3046	H	42.97	---	-5.81	37.16	---	74.00	54.00	-16.84	Peak
4234	H	44.96	---	-2.31	42.65	---	74.00	54.00	-11.35	Peak
4922	H	40.92	---	0.87	41.79	---	74.00	54.00	-12.21	Peak

**Notes:** AV Means AV detector test data, Peak Means Peak detector test data.  
Emissions attenuated more than 20 dB below the permissible value are not reported.

IEEE 802.11n/HT20

<b>EUT</b>	IPTV BOX	<b>Model Name</b>	CA-EBOX-S12
<b>Temperature</b>	26°C	<b>Relative Humidity</b>	56%
<b>Pressure</b>	960hPa	<b>Test voltage</b>	DC 5V supply by Adapter
<b>Test Mode</b>	TX Low		

Freq. (MHz)	Ant. Pol H/V	Peak Reading (dBuV)	AV Reading (dBuV)	Ant. / CL CF (dB)	Actual Fs		Peak Limit (dBuV/m)	AV Limit (dBuV/m)	Margin (dB)	Remark
					Peak (dBuV/m)	AV (dBuV/m)				
1821	V	49.62	---	-9.16	40.46	---	74.00	54.00	-13.54	Peak
2037	V	48.30	---	-8.58	39.72	---	74.00	54.00	-14.28	Peak
3459	V	47.48	---	-4.95	42.53	---	74.00	54.00	-11.47	Peak
4823	V	43.00	---	0.64	43.64	---	74.00	54.00	-10.36	Peak
N/A										

<b>EUT</b>	IPTV BOX	<b>Model Name</b>	CA-EBOX-S12
<b>Temperature</b>	26°C	<b>Relative Humidity</b>	56%
<b>Pressure</b>	960hPa	<b>Test voltage</b>	DC 5V supply by Adapter
<b>Test Mode</b>	TX Low		

Freq. (MHz)	Ant. Pol H/V	Peak Reading (dBuV)	AV Reading (dBuV)	Ant. / CL CF (dB)	Actual Fs		Peak Limit (dBuV/m)	AV Limit (dBuV/m)	Margin (dB)	Remark
					Peak (dBuV/m)	AV (dBuV/m)				
1432	H	47.80	---	-10.29	37.51	---	74.00	54.00	-16.49	Peak
1649	H	47.97	---	-9.84	38.13	---	74.00	54.00	-15.87	Peak
2853	H	49.44	---	-5.87	43.57	---	74.00	54.00	-10.43	Peak
4823	H	42.11	---	0.64	42.75	---	74.00	54.00	-11.25	Peak
N/A										

**Notes:** AV Means AV detector test data, Peak Means Peak detector test data.  
Emissions attenuated more than 20 dB below the permissible value are not reported.



<b>EUT</b>	IPTV BOX	<b>Model Name</b>	CA-EBOX-S12
<b>Temperature</b>	26°C	<b>Relative Humidity</b>	56%
<b>Pressure</b>	960hPa	<b>Test voltage</b>	DC 5V supply by Adapter
<b>Test Mode</b>	TX Mid		

Freq. (MHz)	Ant. Pol H/V	Peak Reading (dBuV)	AV Reading (dBuV)	Ant. / CL CF (dB)	Actual Fs		Peak Limit (dBuV/m)	AV Limit (dBuV/m)	Margin (dB)	Remark
					Peak (dBuV/m)	AV (dBuV/m)				
1194	V	49.01	---	-11.73	37.28	---	74.00	54.00	-16.72	Peak
1963	V	47.29	---	-8.64	38.65	---	74.00	54.00	-15.35	Peak
3572	V	48.18	---	-4.76	43.42	---	74.00	54.00	-10.58	Peak
4871	V	41.81	---	0.76	42.57	---	74.00	54.00	-11.43	Peak

<b>EUT</b>	IPTV BOX	<b>Model Name</b>	CA-EBOX-S12
<b>Temperature</b>	26°C	<b>Relative Humidity</b>	56%
<b>Pressure</b>	960hPa	<b>Test voltage</b>	DC 5V supply by Adapter
<b>Test Mode</b>	TX Mid		

Freq. (MHz)	Ant. Pol H/V	Peak Reading (dBuV)	AV Reading (dBuV)	Ant. / CL CF (dB)	Actual Fs		Peak Limit (dBuV/m)	AV Limit (dBuV/m)	Margin (dB)	Remark
					Peak (dBuV/m)	AV (dBuV/m)				
1736	H	48.84	---	-9.53	39.31	---	74.00	54.00	-14.69	Peak
2684	H	45.19	---	-6.94	38.25	---	74.00	54.00	-15.75	Peak
3511	H	46.56	---	-4.87	41.69	---	74.00	54.00	-12.31	Peak
4871	H	41.76	---	0.76	42.52	---	74.00	54.00	-11.48	Peak

**Notes:** AV Means AV detector test data, Peak Means Peak detector test data.  
Emissions attenuated more than 20 dB below the permissible value are not reported.

<b>EUT</b>	IPTV BOX	<b>Model Name</b>	CA-EBOX-S12
<b>Temperature</b>	26°C	<b>Relative Humidity</b>	56%
<b>Pressure</b>	960hPa	<b>Test voltage</b>	DC 5V supply by Adapter
<b>Test Mode</b>	TX High		

Freq. (MHz)	Ant. Pol H/V	Peak Reading (dBuV)	AV Reading (dBuV)	Ant. / CL CF (dB)	Actual Fs		Peak Limit (dBuV/m)	AV Limit (dBuV/m)	Margin (dB)	Remark
					Peak (dBuV/m)	AV (dBuV/m)				
1324	V	48.49	---	-10.84	37.65	---	74.00	54.00	-16.35	Peak
1762	V	48.00	---	-9.27	38.73	---	74.00	54.00	-15.27	Peak
2028	V	49.30	---	-8.58	40.72	---	74.00	54.00	-13.28	Peak
4922	V	40.67	---	0.87	41.54	---	74.00	54.00	-12.46	Peak

<b>EUT</b>	IPTV BOX	<b>Model Name</b>	CA-EBOX-S12
<b>Temperature</b>	26°C	<b>Relative Humidity</b>	56%
<b>Pressure</b>	960hPa	<b>Test voltage</b>	DC 5V supply by Adapter
<b>Test Mode</b>	TX High		

Freq. (MHz)	Ant. Pol H/V	Peak Reading (dBuV)	AV Reading (dBuV)	Ant. / CL CF (dB)	Actual Fs		Peak Limit (dBuV/m)	AV Limit (dBuV/m)	Margin (dB)	Remark
					Peak (dBuV/m)	AV (dBuV/m)				
1937	H	48.54	---	-8.86	39.68	---	74.00	54.00	-14.32	Peak
3426	H	43.26	---	-5.09	38.17	---	74.00	54.00	-15.83	Peak
4158	H	44.74	---	-2.48	42.26	---	74.00	54.00	-11.74	Peak
4922	H	40.60	---	0.87	41.47	---	74.00	54.00	-12.53	Peak

**Notes:** AV Means AV detector test data, Peak Means Peak detector test data.  
Emissions attenuated more than 20 dB below the permissible value are not reported.

IEEE 802.11n/HT40

<b>EUT</b>	IPTV BOX	<b>Model Name</b>	CA-EBOX-S12
<b>Temperature</b>	26°C	<b>Relative Humidity</b>	56%
<b>Pressure</b>	960hPa	<b>Test voltage</b>	DC 5V supply by Adapter
<b>Test Mode</b>	TX Low		

Freq. (MHz)	Ant. Pol H/V	Peak Reading (dBuV)	AV Reading (dBuV)	Ant. / CL CF (dB)	Actual Fs		Peak Limit (dBuV/m)	AV Limit (dBuV/m)	Margin (dB)	Remark
					Peak (dBuV/m)	AV (dBuV/m)				
1821	V	47.69	---	-9.16	38.53	---	74.00	54.00	-15.47	Peak
2037	V	45.69	---	-8.58	37.11	---	74.00	54.00	-16.89	Peak
3459	V	45.19	---	-4.95	40.24	---	74.00	54.00	-13.76	Peak
4843	V	41.95	---	0.64	42.59	---	74.00	54.00	-11.41	Peak
N/A										

<b>EUT</b>	IPTV BOX	<b>Model Name</b>	CA-EBOX-S12
<b>Temperature</b>	26°C	<b>Relative Humidity</b>	56%
<b>Pressure</b>	960hPa	<b>Test voltage</b>	DC 5V supply by Adapter
<b>Test Mode</b>	TX Low		

Freq. (MHz)	Ant. Pol H/V	Peak Reading (dBuV)	AV Reading (dBuV)	Ant. / CL CF (dB)	Actual Fs		Peak Limit (dBuV/m)	AV Limit (dBuV/m)	Margin (dB)	Remark
					Peak (dBuV/m)	AV (dBuV/m)				
1432	H	47.75	---	-10.29	37.46	---	74.00	54.00	-16.54	Peak
1649	H	48.02	---	-9.84	38.18	---	74.00	54.00	-15.82	Peak
2853	H	48.52	---	-5.87	42.65	---	74.00	54.00	-11.35	Peak
4843	H	40.53	---	0.64	41.17	---	74.00	54.00	-12.83	Peak
N/A										

**Notes:** AV Means AV detector test data, Peak Means Peak detector test data.  
Emissions attenuated more than 20 dB below the permissible value are not reported.

<b>EUT</b>	IPTV BOX	<b>Model Name</b>	CA-EBOX-S12
<b>Temperature</b>	26°C	<b>Relative Humidity</b>	56%
<b>Pressure</b>	960hPa	<b>Test voltage</b>	DC 5V supply by Adapter
<b>Test Mode</b>	TX Mid		

Freq. (MHz)	Ant. Pol H/V	Peak Reading (dBuV)	AV Reading (dBuV)	Ant. / CL CF (dB)	Actual Fs		Peak Limit (dBuV/m)	AV Limit (dBuV/m)	Margin (dB)	Remark
					Peak (dBuV/m)	AV (dBuV/m)				
1194	V	49.10	---	-11.73	37.37	---	74.00	54.00	-16.63	Peak
1963	V	45.75	---	-8.64	37.11	---	74.00	54.00	-16.89	Peak
3572	V	47.18	---	-4.76	42.42	---	74.00	54.00	-11.58	Peak
4871	V	41.77	---	0.76	42.53	---	74.00	54.00	-11.47	Peak

<b>EUT</b>	IPTV BOX	<b>Model Name</b>	CA-EBOX-S12
<b>Temperature</b>	26°C	<b>Relative Humidity</b>	56%
<b>Pressure</b>	960hPa	<b>Test voltage</b>	DC 5V supply by Adapter
<b>Test Mode</b>	TX Mid		

Freq. (MHz)	Ant. Pol H/V	Peak Reading (dBuV)	AV Reading (dBuV)	Ant. / CL CF (dB)	Actual Fs		Peak Limit (dBuV/m)	AV Limit (dBuV/m)	Margin (dB)	Remark
					Peak (dBuV/m)	AV (dBuV/m)				
1736	H	47.91	---	-9.53	38.38	---	74.00	54.00	-15.62	Peak
2684	H	43.41	---	-6.94	36.47	---	74.00	54.00	-17.53	Peak
3511	H	47.92	---	-4.87	43.05	---	74.00	54.00	-10.95	Peak
4871	H	43.81	---	0.76	44.57	---	74.00	54.00	-9.43	Peak

**Notes:** AV Means AV detector test data, Peak Means Peak detector test data.  
Emissions attenuated more than 20 dB below the permissible value are not reported.

<b>EUT</b>	IPTV BOX	<b>Model Name</b>	CA-EBOX-S12
<b>Temperature</b>	26°C	<b>Relative Humidity</b>	56%
<b>Pressure</b>	960hPa	<b>Test voltage</b>	DC 5V supply by Adapter
<b>Test Mode</b>	TX High		

Freq. (MHz)	Ant. Pol H/V	Peak Reading (dBuV)	AV Reading (dBuV)	Ant. / CL CF (dB)	Actual Fs		Peak Limit (dBuV/m)	AV Limit (dBuV/m)	Margin (dB)	Remark
					Peak (dBuV/m)	AV (dBuV/m)				
1324	V	49.00	---	-10.84	38.16	---	74.00	54.00	-15.84	Peak
1762	V	45.64	---	-9.27	36.37	---	74.00	54.00	-17.63	Peak
2028	V	51.06	---	-8.58	42.48	---	74.00	54.00	-11.52	Peak
4904	V	42.49	---	0.87	43.36	---	74.00	54.00	-10.64	Peak

<b>EUT</b>	IPTV BOX	<b>Model Name</b>	CA-EBOX-S12
<b>Temperature</b>	26°C	<b>Relative Humidity</b>	56%
<b>Pressure</b>	960hPa	<b>Test voltage</b>	DC 5V supply by Adapter
<b>Test Mode</b>	TX High		

Freq. (MHz)	Ant. Pol H/V	Peak Reading (dBuV)	AV Reading (dBuV)	Ant. / CL CF (dB)	Actual Fs		Peak Limit (dBuV/m)	AV Limit (dBuV/m)	Margin (dB)	Remark
					Peak (dBuV/m)	AV (dBuV/m)				
1937	H	47.14	---	-8.86	38.28	---	74.00	54.00	-15.72	Peak
3426	H	42.25	---	-5.09	37.16	---	74.00	54.00	-16.84	Peak
4158	H	44.10	---	-2.48	41.62	---	74.00	54.00	-12.38	Peak
4904	H	41.70	---	0.87	42.57	---	74.00	54.00	-11.43	Peak

**Notes:** AV Means AV detector test data, Peak Means Peak detector test data.  
Emissions attenuated more than 20 dB below the permissible value are not reported.

## 6 POWER LINE CONDUCTED EMISSION

### 6.1 Conducted Emission Limits(15.209&249)

Frequency MHz	Limits dB( $\mu$ V)	
	Quasi-peak Level	Average Level
0.15 -0.50	66 -56*	56 - 46*
0.50 -5.00	56	46
5.00 -30.00	60	50

- Notes: 1. \*Decreasing linearly with logarithm of frequency.  
 2. The lower limit shall apply at the transition frequencies.  
 3. The limit decreases in line with the logarithm of the frequency in the rang of 0.15 to 0.50 MHz.

### 6.2 Test Setup

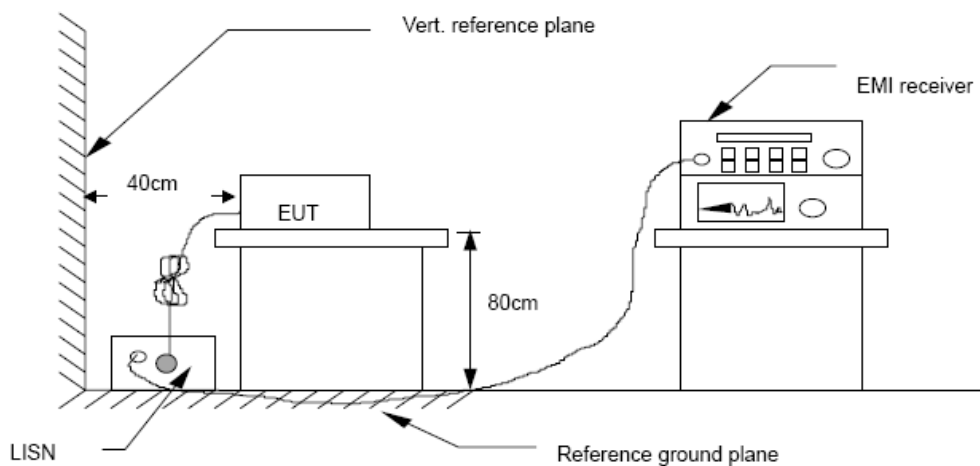

### 6.3 Test Procedure

The EUT is put on the plane 0.8m high above the ground by insulating support and is connected to the power mains through a line impedance stabilization network (L.I.S.N.). This provides a 50ohm coupling impedance for the EUT system. Please refer the block diagram of the test setup and photographs. Both sides of AC lines are checked to find out the maximum conducted emission. In order to find the maximum emission levels, the relative positions of equipment and all of the interface cables shall be changed according to ANSI C63.4-2003 on Conducted Emission Measurement.

The bandwidth of test receiver (R & S ESCS30) is set at 9 kHz.

### 6.4 Test Results

**PASS**

Detailed information please see the following page.



Shenzhen Certification Technology Service Co., Ltd.  
 2F, Building B, East Area of Nanchang Second Industrial Zone,  
 Gushu 2nd Road, Bao'an District, Shenzhen 518126, P.R. China  
 Tel: 4006786199 Fax: +86-755-26738857  
 Website: <http://www.cessz.com> Email: [Service@cessz.com](mailto:Service@cessz.com)

Data: 1 File: E:\TEST REPORT\Asia\Conduction 0.15-30.EM6 (4) Date: 2012-06-10 Time: 10:06:08

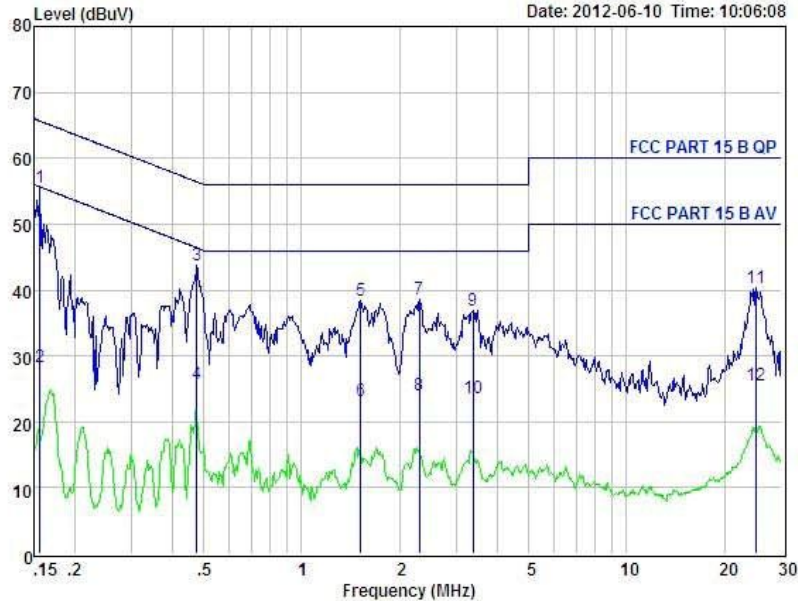

Condition : FCC PART 15 B QP POL: NEUTRAL  
 EUT : IPTV BOX  
 Model No. : CA-EBOX-S12  
 Test Mode : Working  
 Power : AC 120V/60Hz  
 Test Engineer: Store  
 Remark :

Item	Freq MHz	Read dBuV	LISN Factor dB	Preamp Factor dB	Cable Loss dB	Level dBuV	Limit dBuV	Margin dBuV	Remark
1	0.156	45.65	0.03	-9.72	0.10	55.80	65.65	-10.15	QP
2	0.156	18.43	0.03	-9.72	0.10	28.28	55.65	-27.37	Average
3	0.476	33.81	0.03	-9.72	0.10	43.66	56.41	-12.75	QP
4	0.476	15.87	0.03	-9.72	0.10	25.72	46.41	-20.69	Average
5	1.519	28.58	0.05	-9.71	0.10	38.44	56.00	-17.56	QP
6	1.519	13.23	0.05	-9.71	0.10	23.09	46.00	-22.91	Average
7	2.309	28.64	0.06	-9.70	0.11	38.51	56.00	-17.49	QP
8	2.309	14.08	0.06	-9.70	0.11	23.95	46.00	-22.05	Average
9	3.364	27.08	0.08	-9.69	0.12	36.97	56.00	-19.03	QP
10	3.364	13.80	0.08	-9.69	0.12	23.69	46.00	-22.31	Average
11	25.055	29.77	0.46	-9.59	0.48	40.30	60.00	-19.70	QP
12	25.055	15.07	0.46	-9.59	0.48	25.60	50.00	-24.40	Average





Shenzhen Certification Technology Service Co., Ltd.  
 2F, Building B, East Area of Nanchang Second Industrial Zone,  
 Gushu 2nd Road, Bao'an District, Shenzhen 518126, P.R. China  
 Tel: 4006786199 Fax: +86-755-26738857  
 Website: <http://www.cessz.com> Email: [Service@cessz.com](mailto:Service@cessz.com)

Data: 3 File: E:\TEST REPORT\Asia\Conduction 0.15-30.EM6 (4) Date: 2012-06-10 Time: 10:07:49

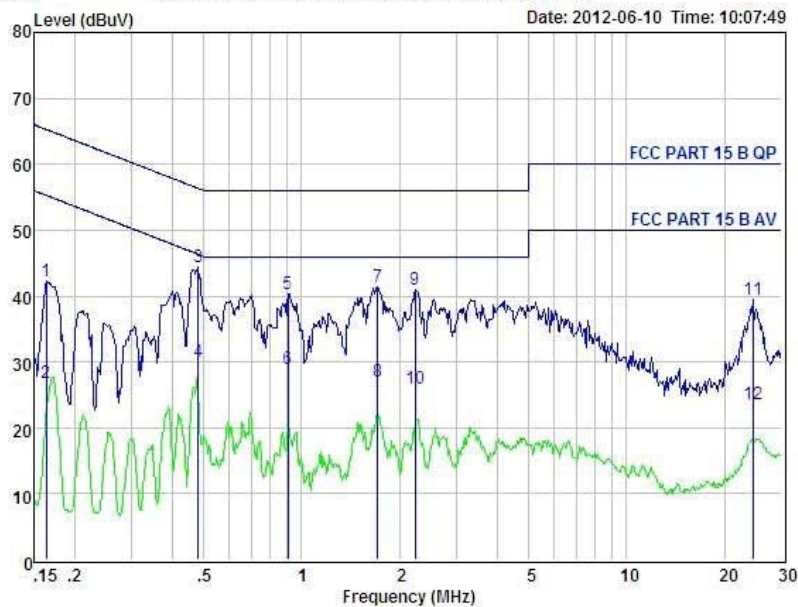

Condition : FCC PART 15 B QP POL: LINE  
 EUT : IPTV BOX  
 Model No. : CA-EBOX-S12  
 Test Mode : Working  
 Power : AC 120V/60Hz  
 Test Engineer: Store  
 Remark :

Item	Freq MHz	Read dBuV	LISN Factor dB	Preamp Factor dB	Cable Loss dB	Level dBuV	Limit dBuV	Margin dBuV	Remark
1	0.164	32.32	0.03	-9.72	0.10	42.17	65.25	-23.08	QP
2	0.164	17.04	0.03	-9.72	0.10	26.89	55.25	-28.36	Average
3	0.481	34.50	0.03	-9.72	0.10	44.35	56.32	-11.97	QP
4	0.481	20.10	0.03	-9.72	0.10	29.95	46.32	-16.37	Average
5	0.909	30.53	0.04	-9.71	0.10	40.38	56.00	-15.62	QP
6	0.909	19.10	0.04	-9.71	0.10	28.95	46.00	-17.05	Average
7	1.716	31.58	0.05	-9.70	0.10	41.43	56.00	-14.57	QP
8	1.716	17.08	0.05	-9.70	0.10	26.93	46.00	-19.07	Average
9	2.237	31.16	0.06	-9.70	0.10	41.02	56.00	-14.98	QP
10	2.237	16.11	0.06	-9.70	0.10	25.97	46.00	-20.03	Average
11	24.529	28.91	0.46	-9.58	0.47	39.42	60.00	-20.58	QP
12	24.529	13.14	0.46	-9.58	0.47	23.65	50.00	-26.35	Average



Shenzhen Certification Technology Service Co., Ltd.  
 2F, Building B, East Area of Nanchang Second Industrial Zone,  
 Gushu 2nd Road, Bao'an District, Shenzhen 518126, P.R. China  
 Tel: 4006786199 Fax: +86-755-26738857  
 Website: <http://www.cessz.com> Email: [Service@cessz.com](mailto:Service@cessz.com)

Data: 1 File: E:\TEST REPORT\Champion\Conduction 0.15-30.EM6 (4) Date: 2012-07-17 Time: 14:42:23

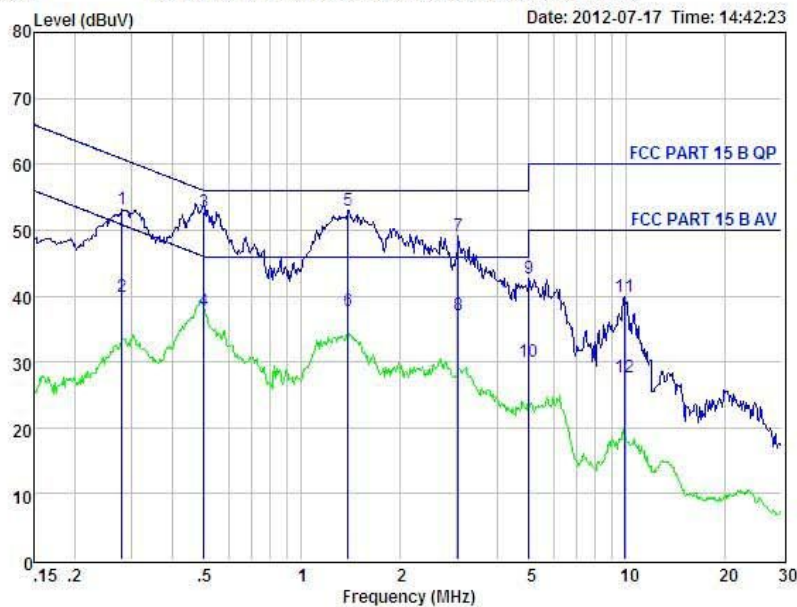

Condition : FCC PART 15 B QP POL: LINE  
 EUI : IPTV BOX  
 Model No : CA-EBOX-S12  
 Test Mode : Data Transmission  
 Power : AC 120V/60Hz  
 Test Engineer: Store  
 Remark :

Item	Freq MHz	Read dBUV	LISN Factor dB	Preamp Factor dB	Cable Loss dB	Level dBUV	Limit dBUV	Margin dBUV	Remark
1	0.280	43.24	0.03	-9.72	0.10	53.09	60.81	-7.72	QP
2	0.280	30.04	0.03	-9.72	0.10	39.89	50.81	-10.92	Average
3	0.499	42.86	0.03	-9.72	0.10	52.71	56.01	-3.30	QP
4	0.499	27.86	0.03	-9.72	0.10	37.71	46.01	-8.30	Average
5	1.388	43.05	0.05	-9.71	0.10	52.91	56.00	-3.09	QP
6	1.388	27.96	0.05	-9.71	0.10	37.82	46.00	-8.18	Average
7	3.041	39.14	0.07	-9.69	0.12	49.02	56.00	-6.98	QP
8	3.041	27.14	0.07	-9.69	0.12	37.02	46.00	-8.98	Average
9	5.005	32.87	0.10	-9.68	0.12	42.77	60.00	-17.23	QP
10	5.005	20.09	0.10	-9.68	0.12	29.99	50.00	-20.01	Average
11	9.861	30.05	0.18	-9.35	0.21	39.79	60.00	-20.21	QP
12	9.861	17.98	0.18	-9.35	0.21	27.72	50.00	-22.28	Average



Shenzhen Certification Technology Service Co., Ltd.  
 2F, Building B, East Area of Nanchang Second Industrial Zone,  
 Gushu 2nd Road, Bao'an District, Shenzhen 518126, P.R. China  
 Tel: 4006786199 Fax: +86-755-26738857  
 Website: <http://www.cessz.com> Email: [Service@cessz.com](mailto:Service@cessz.com)

Data: 3 File: E:\TEST REPORT\C\Champion\Conduction 0.15-30.EM6 (4) Date: 2012-07-17 Time: 14:45:12

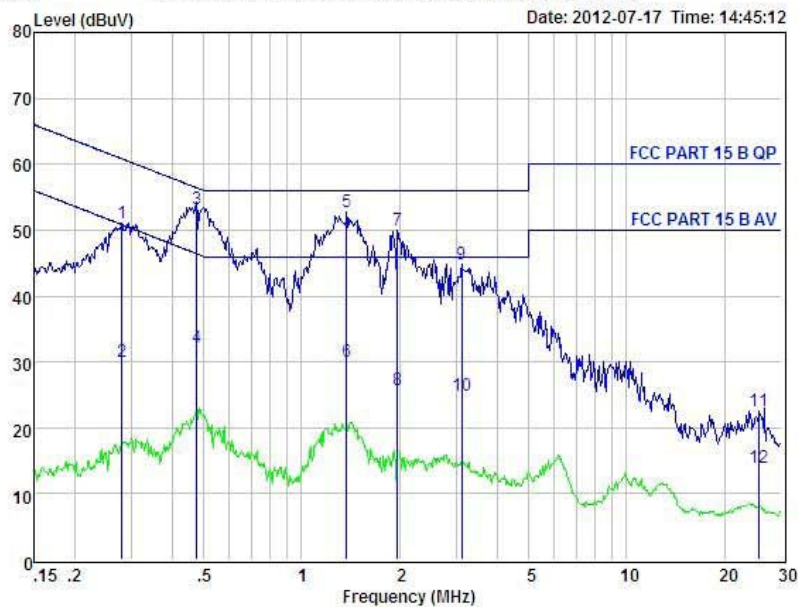

Condition : FCC PART 15 B QP POL: NEUTRAL  
 EUI : IPTV BOX  
 Model No : CA-EBOX-S12  
 Test Mode : Data Transmission  
 Power : AC 120V/60Hz  
 Test Engineer: Store  
 Remark :

Item	Freq MHz	Read dBuV	LISN Factor dB	Preamp Factor dB	Cable Loss dB	Level dBuV	Limit dBuV	Margin dBuV	Remark
1	0.280	41.14	0.03	-9.72	0.10	50.99	60.81	-9.82	QP
2	0.280	20.14	0.03	-9.72	0.10	29.99	50.81	-20.82	Average
3	0.476	43.32	0.03	-9.72	0.10	53.17	56.41	-3.24	QP
4	0.476	22.24	0.03	-9.72	0.10	32.09	46.41	-14.32	Average
5	1.374	42.83	0.05	-9.71	0.10	52.69	56.00	-3.31	QP
6	1.374	20.20	0.05	-9.71	0.10	30.06	46.00	-15.94	Average
7	1.970	40.19	0.06	-9.70	0.10	50.05	56.00	-5.95	QP
8	1.970	15.87	0.06	-9.70	0.10	25.73	46.00	-20.27	Average
9	3.107	34.87	0.07	-9.69	0.12	44.75	56.00	-11.25	QP
10	3.107	15.05	0.07	-9.69	0.12	24.93	46.00	-21.07	Average
11	25.591	11.93	0.46	-9.62	0.50	22.51	60.00	-37.49	QP
12	25.591	3.30	0.46	-9.62	0.50	13.88	50.00	-36.12	Average

## 7 Peak Power

### 7.1 Test limit

Please refer section 15.247.

Regulation 15.247(b) The limit of Maximum Peak Output Power Measurement is 1W(30dBm)

### 7.2 Test Procedure

- 7.2.1 Place the EUT on the table and set it in transmitting mode.
- 7.2.2 Remove the antenna from the EUT and then connect a low loss RF cable from the antenna port to the spectrum analyzer.
- 7.2.3 Set the spectrum analyzer as RBW = 1MHz, VBW = 3MHz, Sweep=auto.
- 7.2.4 Record the max. reading.
- 7.2.5 Repeat the above procedure until the measurements for all frequencies are completed.

### 7.3 Test Setup

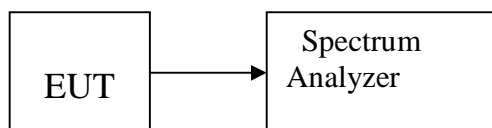

### 7.4 Test Results

**PASS**

Detailed information please see the following page.

Channel	Frequency (MHz)	Reading Power (dBm)	Factor (dB)	Out put Power (dBm)	Out put Power (W)	Limit (W)	Result
IEEE 802.11b:							
Mid	2412	10.30	0	10.30	0.01072	1	PASS
High	2437	11.56	0	11.56	0.01432		PASS
Low	2462	11.84	0	11.84	0.01528		PASS
IEEE 802.11g:							
Low	2412	10.35	0	10.35	0.01084	1	PASS
Mid	2437	10.78	0	10.78	0.01191		PASS
High	2462	10.69	0	10.69	0.01172		PASS
IEEE 802.11n/HT20:							
Low	2412	10.43	0	10.43	0.01104	1	PASS
Mid	2437	10.85	0	10.85	0.01216		PASS
High	2462	10.63	0	10.63	0.01156		PASS
IEEE 802.11n/HT40:							
Low	2422	10.41	0	10.41	0.01099	1	PASS
Mid	2437	9.85	0	9.85	0.00966		PASS
High	2452	10.27	0	10.27	0.01064		PASS

IEEE 802.11b:

CH Low :

Agilent

R T

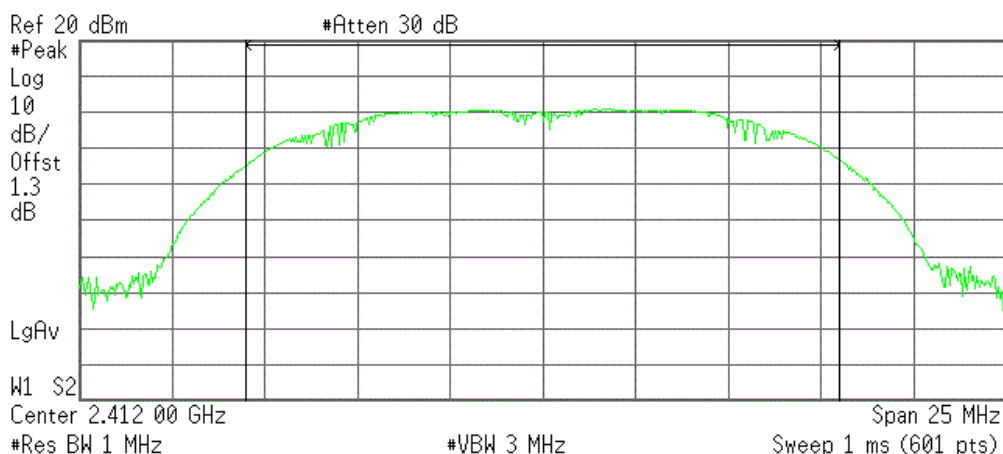

Channel Power

10.30 dBm /16.0000 MHz

Power Spectral Density

-61.74 dBm/Hz

CH Mid :

Agilent

R T

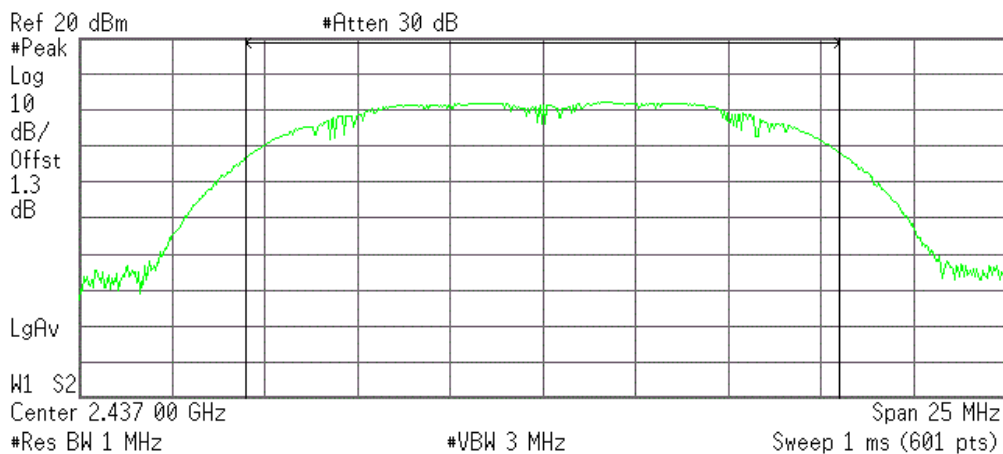

Channel Power

11.56 dBm /16.0000 MHz

Power Spectral Density

-60.48 dBm/Hz

CH High :

Agilent

R T

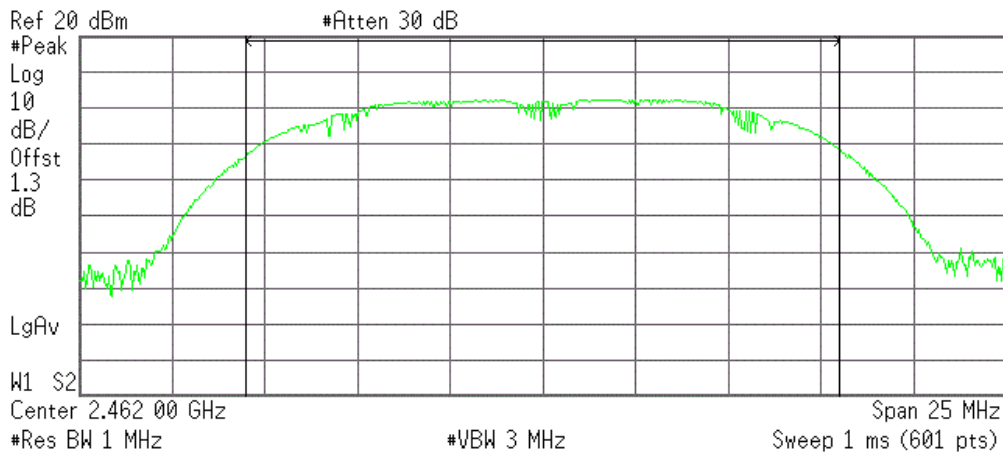

Channel Power

11.84 dBm /16.0000 MHz

Power Spectral Density

-60.20 dBm/Hz

IEEE 802.11g:

CH Low :

Agilent

R T

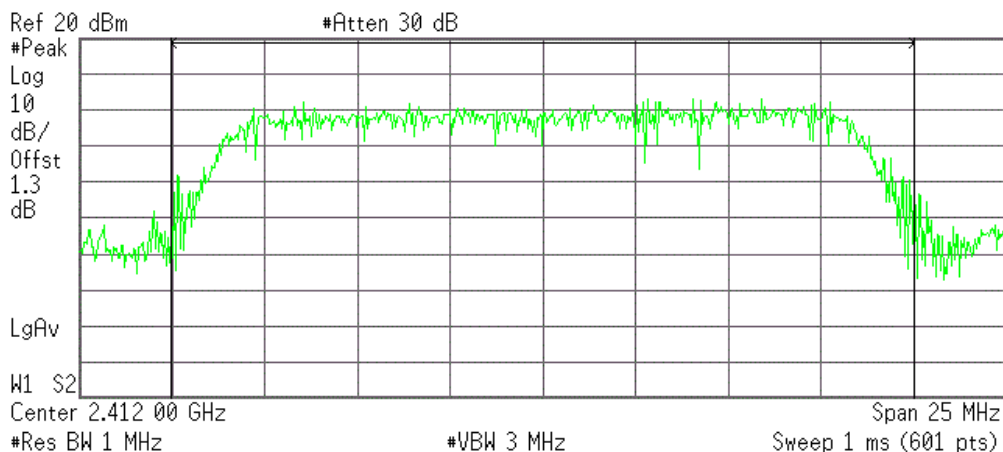

Channel Power

10.35 dBm /20.0000 MHz

Power Spectral Density

-62.66 dBm/Hz

CH Mid :

Agilent

R T

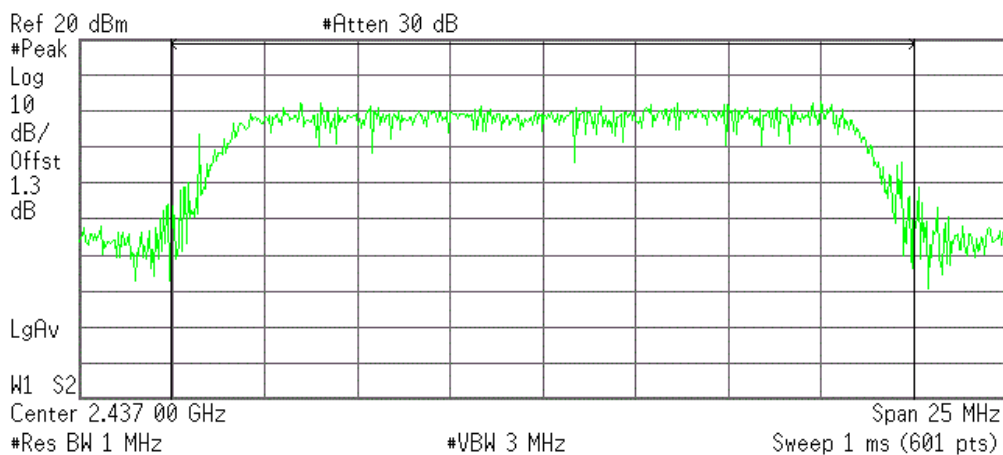

Channel Power

10.78 dBm /20.0000 MHz

Power Spectral Density

-62.23 dBm/Hz

CH High :

Agilent

R T

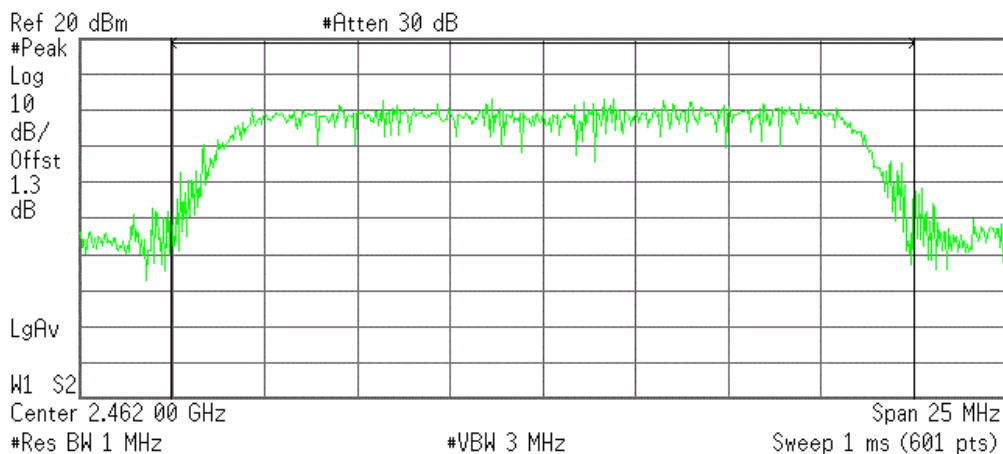

Channel Power

10.69 dBm /20.0000 MHz

Power Spectral Density

-62.32 dBm/Hz



IEEE 802.11n/HT20:

CH Low :

Agilent

R T

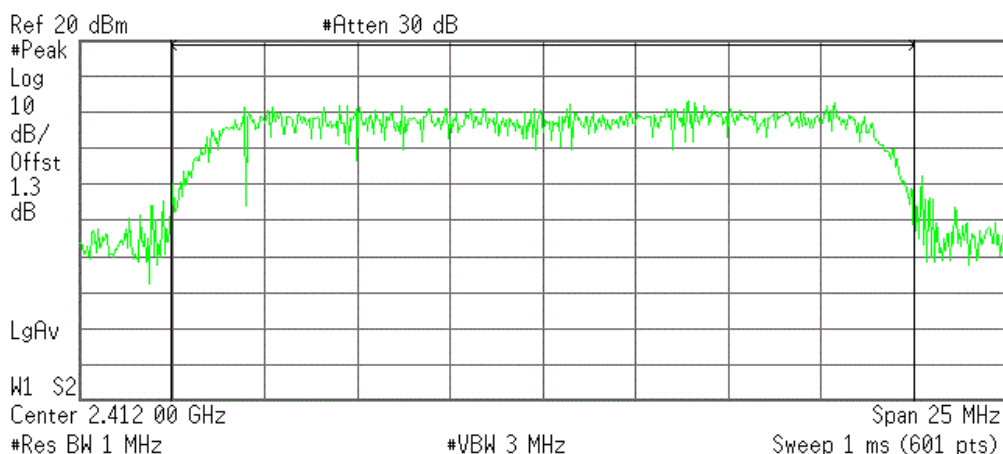

Channel Power

10.43 dBm /20.0000 MHz

Power Spectral Density

-62.58 dBm/Hz

CH Mid :

Agilent

R T

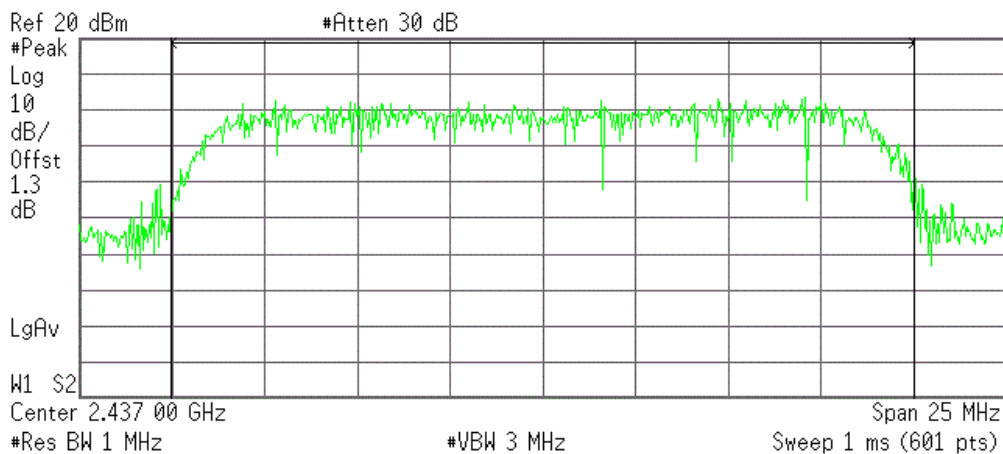

Channel Power

10.85 dBm /20.0000 MHz

Power Spectral Density

-62.16 dBm/Hz

CH High :

Agilent

R T

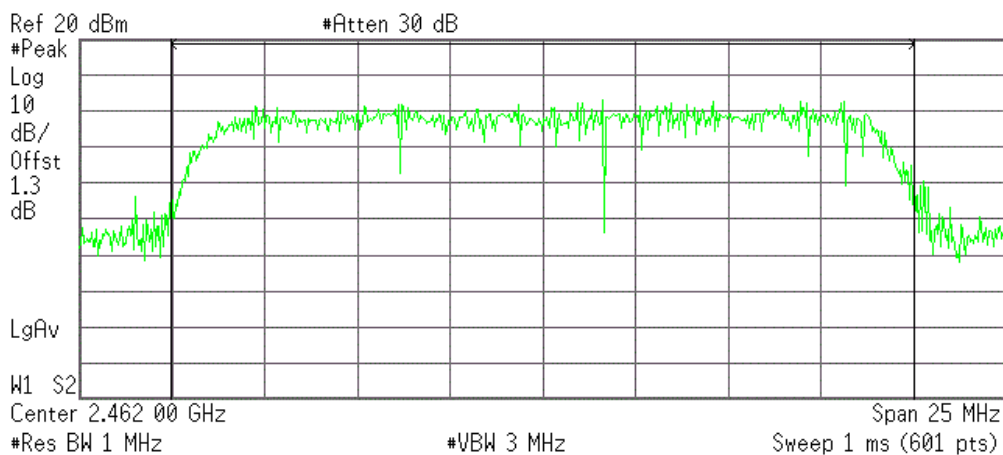

Channel Power

10.63 dBm /20.0000 MHz

Power Spectral Density

-62.38 dBm/Hz

IEEE 802.11n/HT40:

CH Low :

Agilent

R T

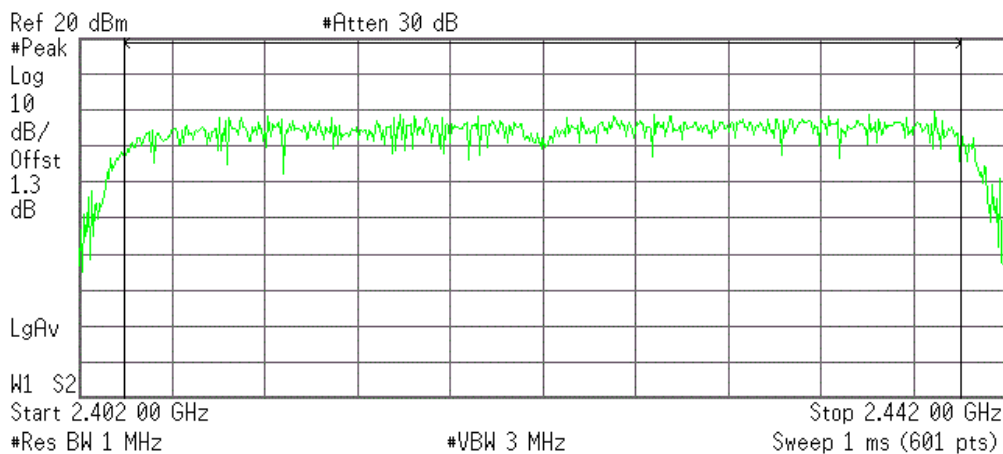

Channel Power

10.41 dBm /36.0000 MHz

Power Spectral Density

-65.15 dBm/Hz

CH Mid :

Agilent

R T

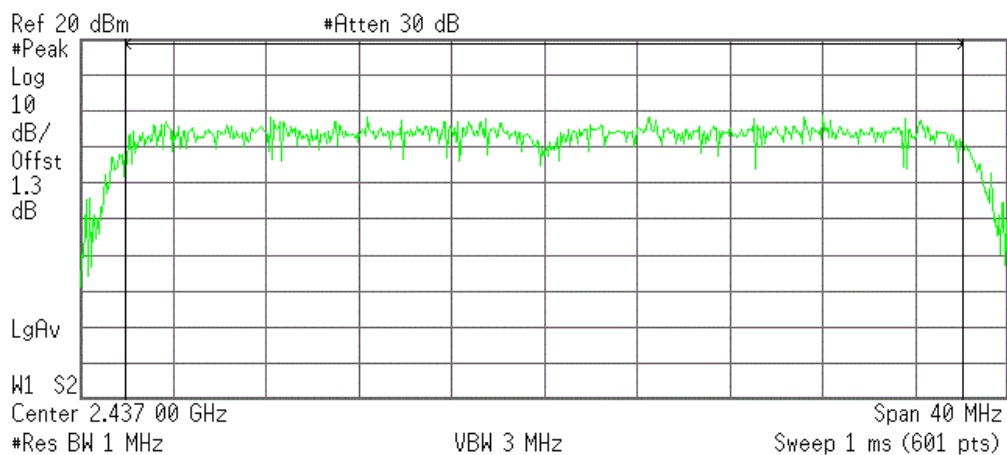

Channel Power

Power Spectral Density

9.85 dBm /36.0000 MHz

-66.17 dBm/Hz

CH High :

Agilent

R T

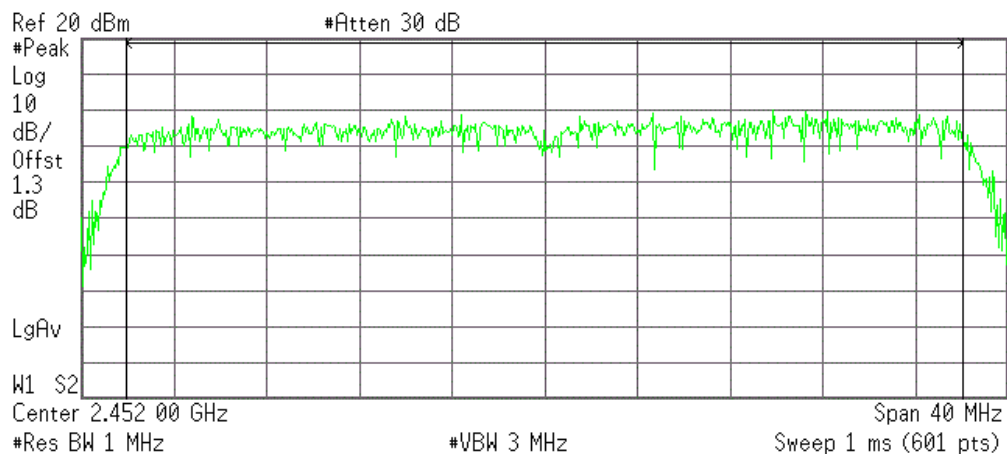

Channel Power

Power Spectral Density

10.27 dBm /36.0000 MHz

-65.29 dBm/Hz

## 8 PEAK POWER SPECTRAL DENSITY

### 8.1 Test limit

- 8.1.1 Please refer section 15.247.
- 8.1.2 For direct sequence systems, the peak power spectral density conducted from the intentional radiator to the antenna shall not be greater than 8dBm in any 3kHz band during any time interval of continuous transmission.
- 8.1.3 The direct sequence operating of the hybrid system, with the frequency hopping operation turned off, shall comply with the power density requirements of paragraph (d) of this section.

### 8.2 Method of measurement

- 8.2.1 Place the EUT on the table and set it in transmitting mode.
- 8.2.2 Remove the antenna from the EUT and then connect a low loss RF cable from the antenna port to the spectrum analyzer.
- 8.2.3 Set the spectrum analyzer as RBW = 100kHz, VBW = 300kHz, span=20%EBW, detail see the test plot.
- 8.2.4 Record the max reading.
- 8.2.5 Repeat the above procedure until the measurements for all frequencies are completed.

### 8.3 Test Setup

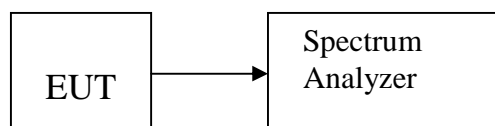

## 8.4 Test Results

PASS.

Detailed information please see the following page.

Channel	Frequency (MHz)	Power Spectral Density (dBm)	BCWF (dBm)	Final Power Spectral Density (dBm)	Limit (dBm)	Result
IEEE 802.11b:						
Mid	2412	-28.69	-15.2	-43.89	8	PASS
High	2437	-25.07	-15.2	-40.27	8	PASS
Low	2462	-24.83	-15.2	-40.03	8	PASS
IEEE 802.11g:						
Low	2412	-28.00	-15.2	-43.20	8	PASS
Mid	2437	-24.27	-15.2	-39.47	8	PASS
High	2462	-24.83	-15.2	-40.03	8	PASS
IEEE 802.11n/HT20:						
Low	2412	-24.32	-15.2	-39.52	8	PASS
Mid	2437	-18.14	-15.2	-33.34	8	PASS
High	2462	-24.51	-15.2	-39.71	8	PASS
IEEE 802.11n/HT40:						
Low	2422	-25.04	-15.2	-40.24	8	PASS
Mid	2437	-29.42	-15.2	-44.62	8	PASS
High	2452	-29.98	-15.2	-45.18	8	PASS
Note: BWCF = $10\log(3\text{ kHz}/100\text{ kHz}) = -15.2\text{ dB}$ .						

IEEE 802.11b:

CH Low :

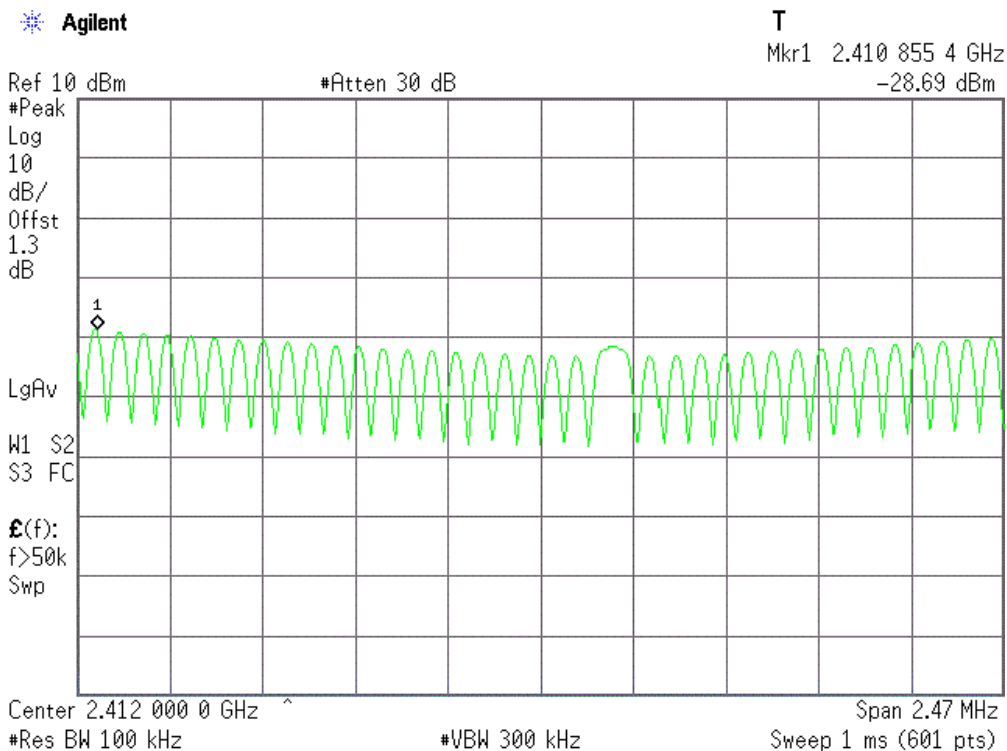

CH Mid :

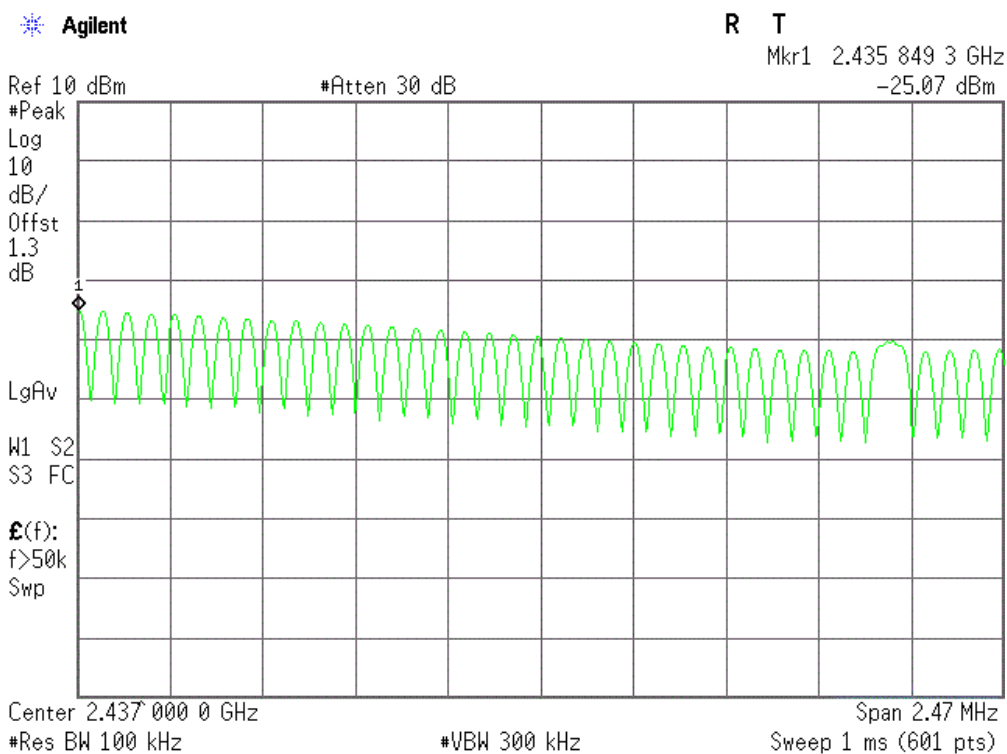

CH High :

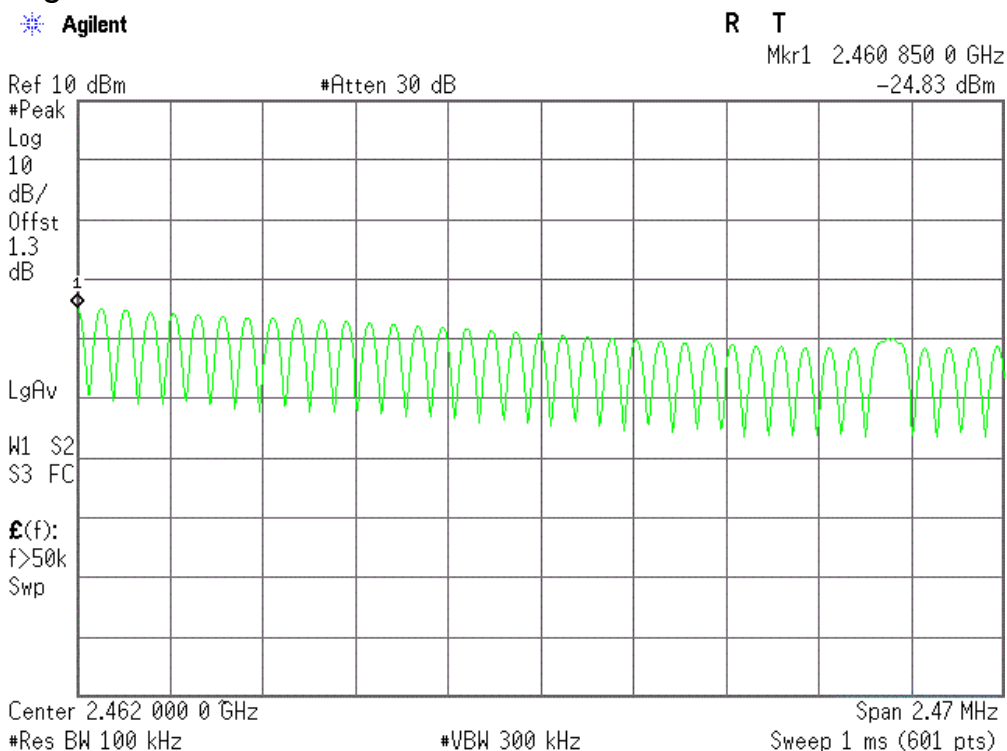

IEEE 802.11g:

CH Low :

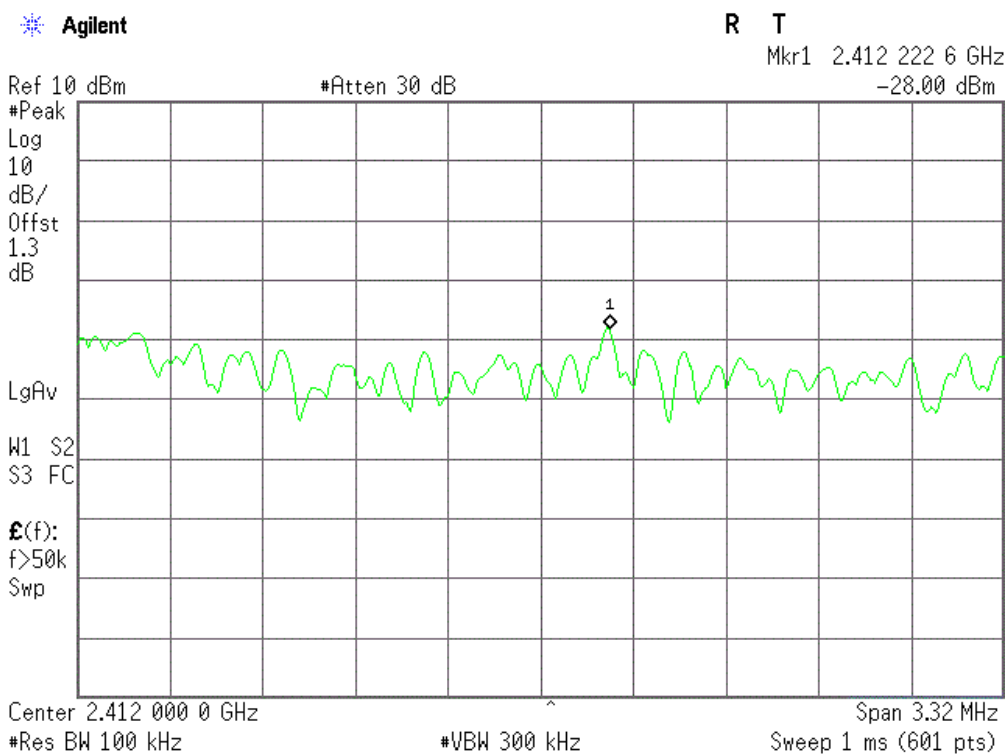

CH Mid :

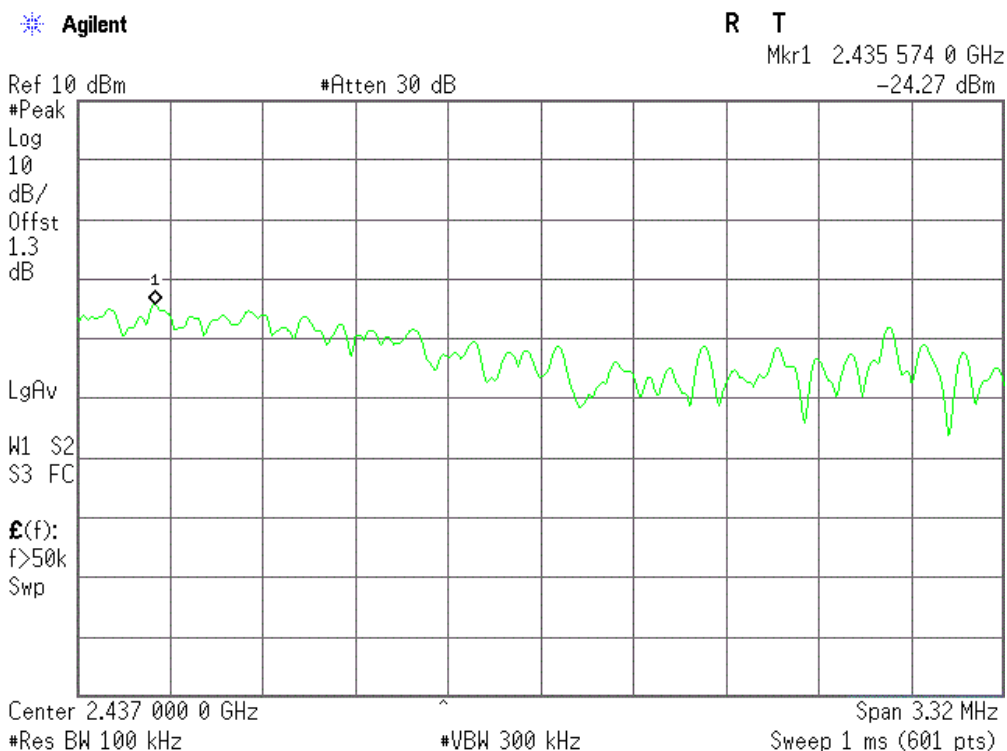

CH High :

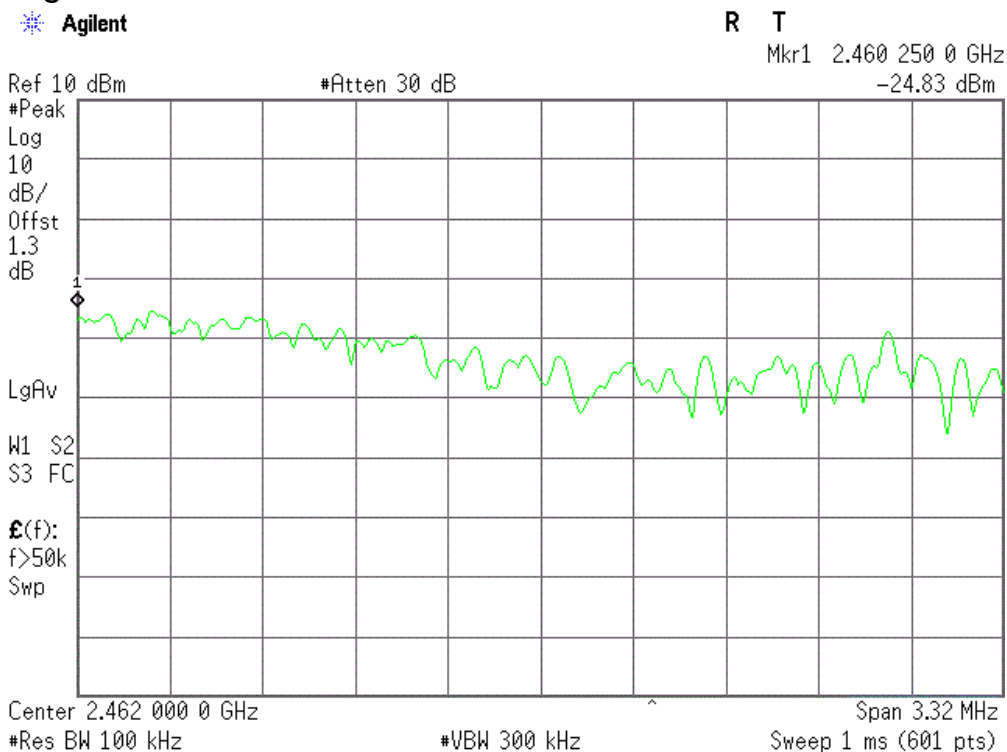



IEEE 802.11n/HT20:

CH Low :

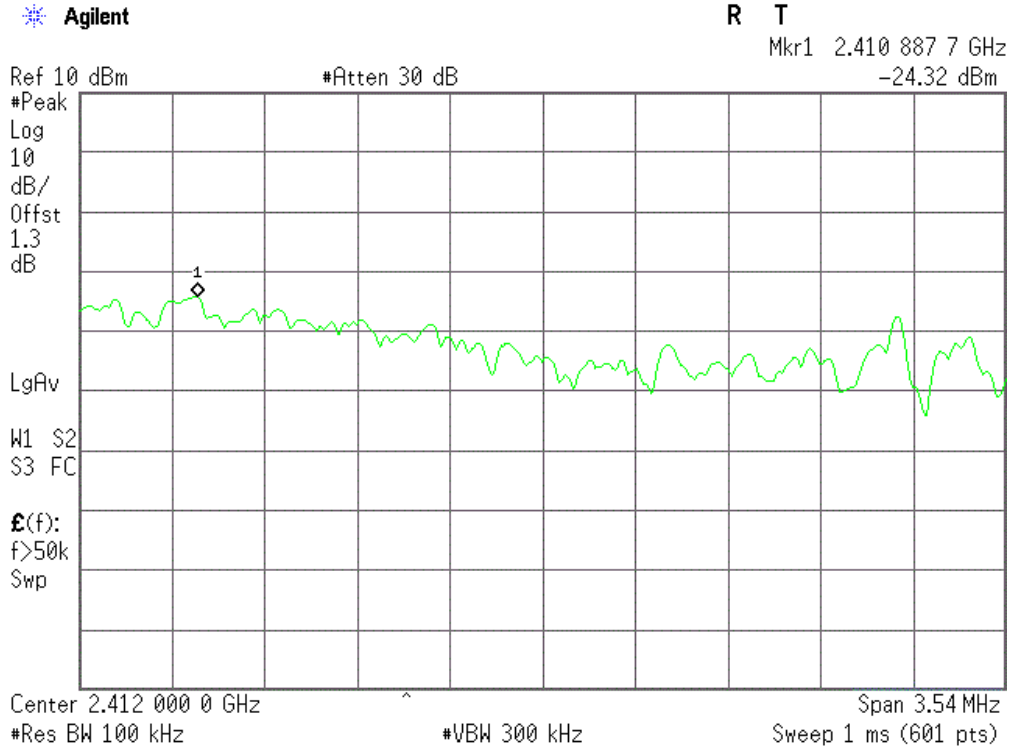

CH Mid :

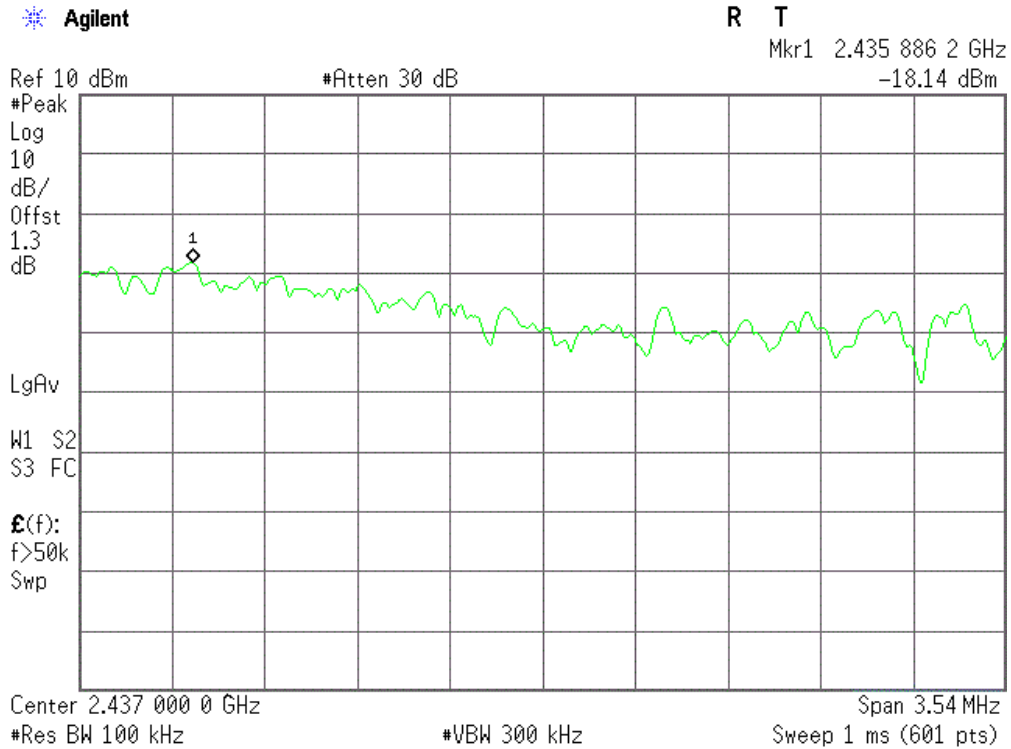

CH High :

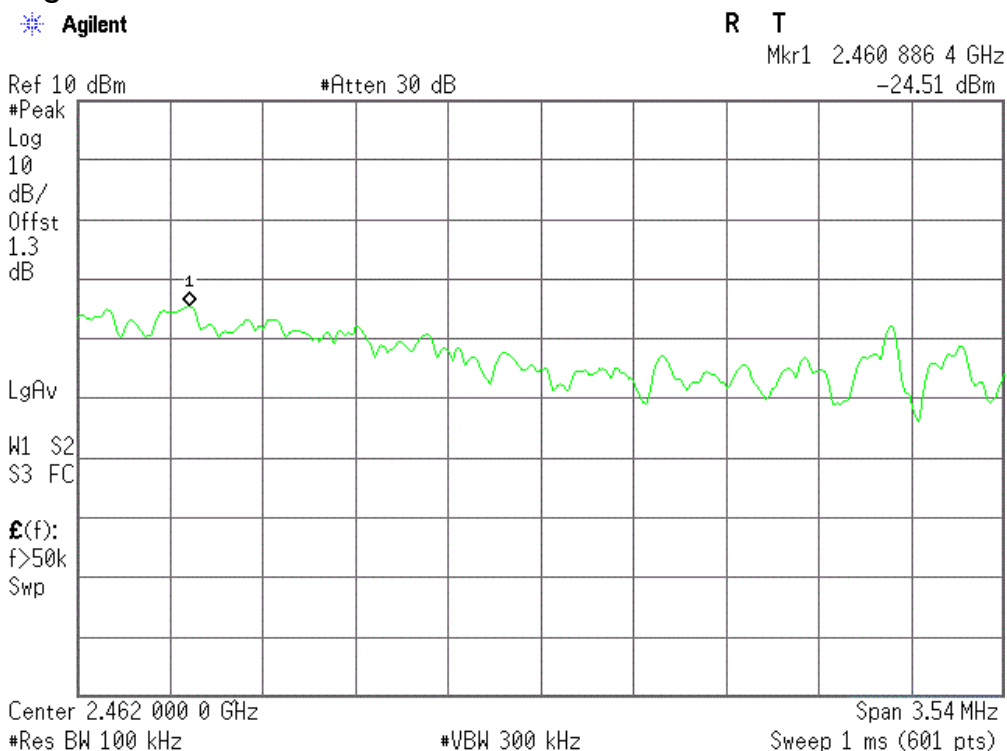

IEEE 802.11n/HT40:

CH Low :

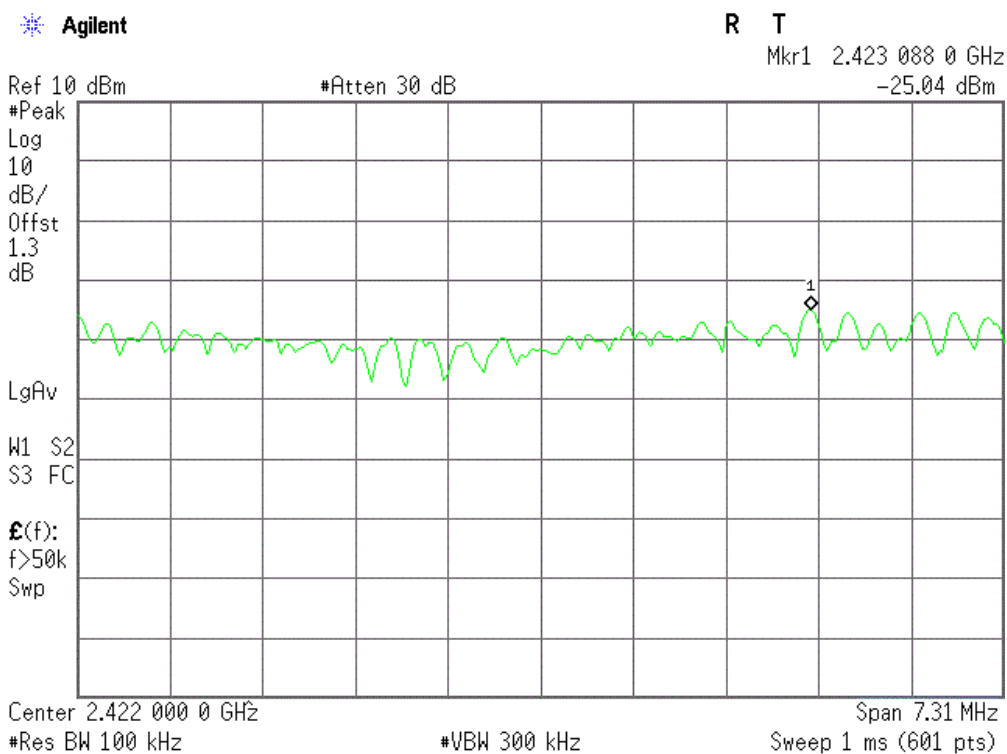

CH Mid :

Agilent

R T

Mkr1 2.438 114 1 GHz  
-29.42 dBm

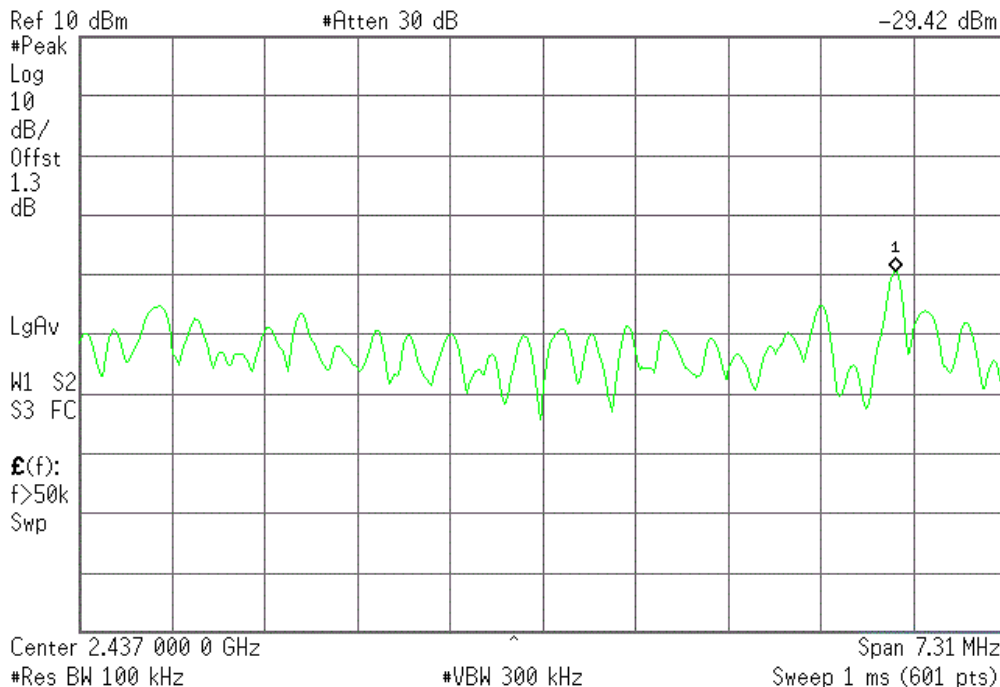

CH High :

Agilent

R T

Mkr1 2.453 113 1 GHz  
-29.98 dBm

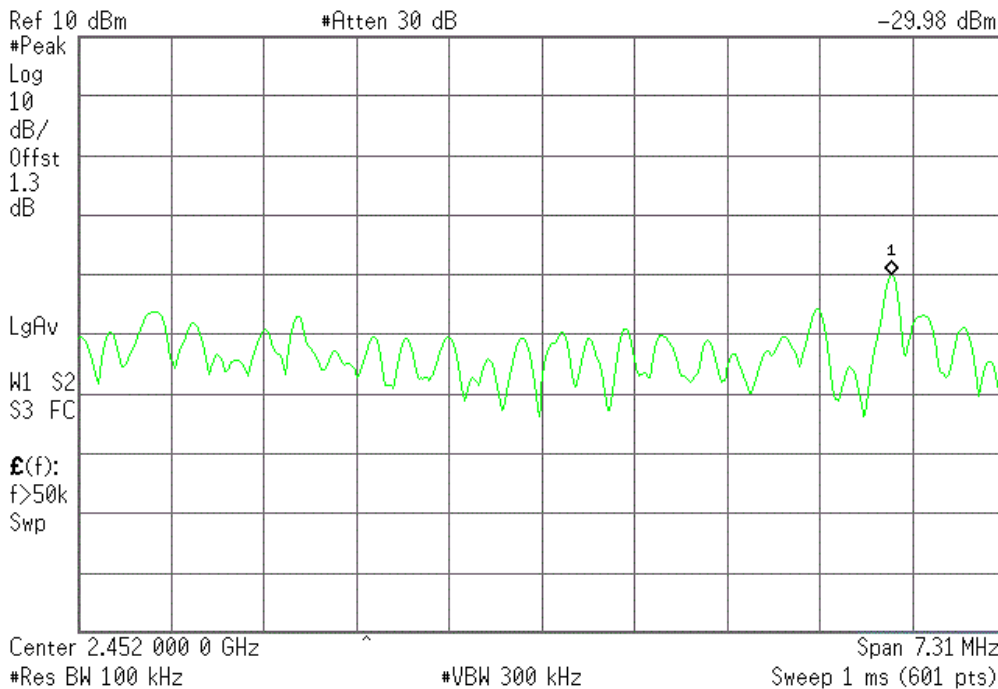

## 9 6dB Bandwidth

### 9.1 Test limit

Please refer section 15.247

For direct sequence systems, the minimum 6dB bandwidth shall be at least 500kHz.

### 9.2 Method of measurement

a) The bandwidth is measured at an amplitude level reduced 20dB from the reference level. The reference level is the level of the highest amplitude signal observed from the transmitter at the fundamental frequency. Once the reference level is established, the equipment is conditioned with typical modulating signal to produce the worst-case (i.e. the widest) bandwidth.

b) The test receiver set  $RBW = 1-5 \% EBW$ ,  $VBW \geq 3RBW$ , Sweep time set auto, detail see the test plot.

### 9.3 Test Setup

Same as 7.3

### 9.4 Test Results

PASS.

Detailed information please see the following page.

IEEE 802.11b:

CH Low :

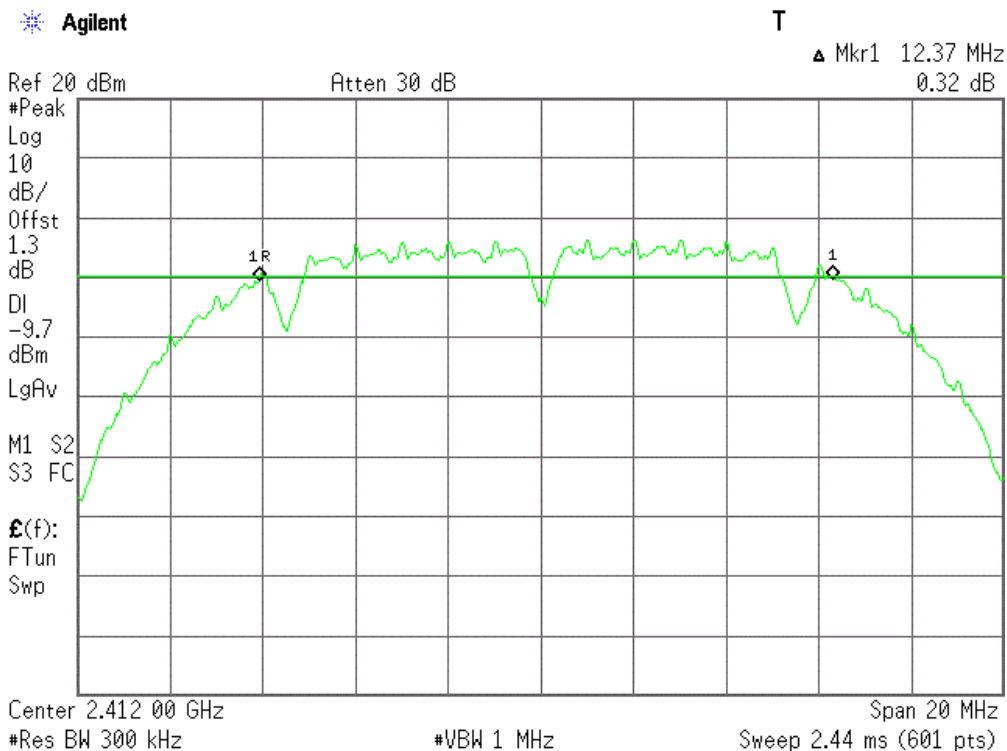

CH Mid :

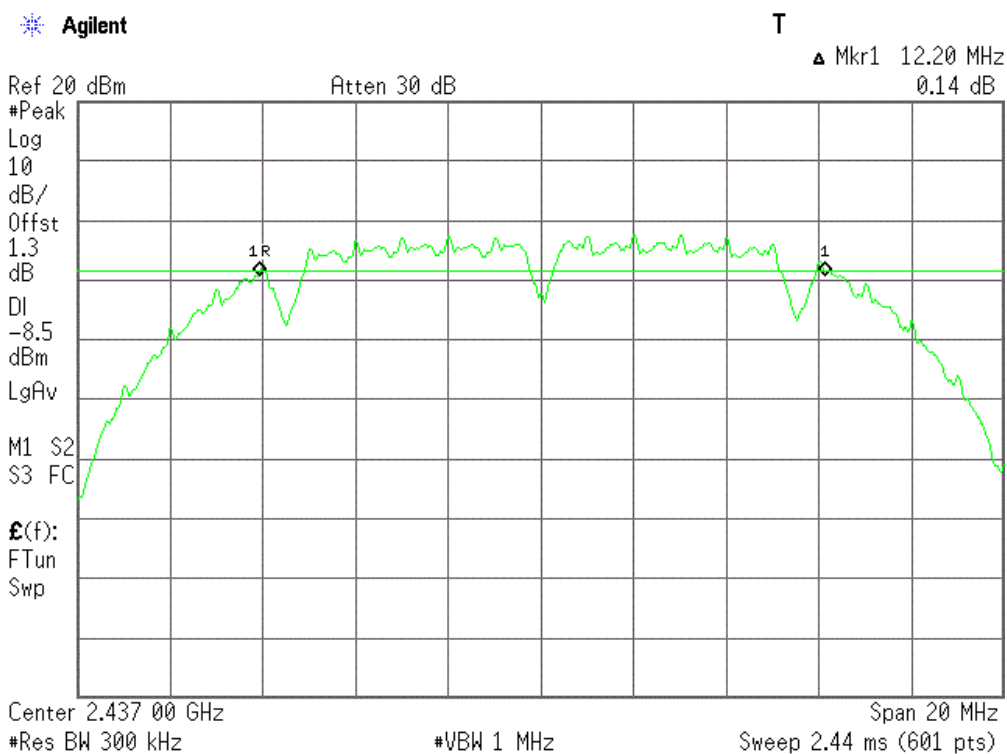

CH High :

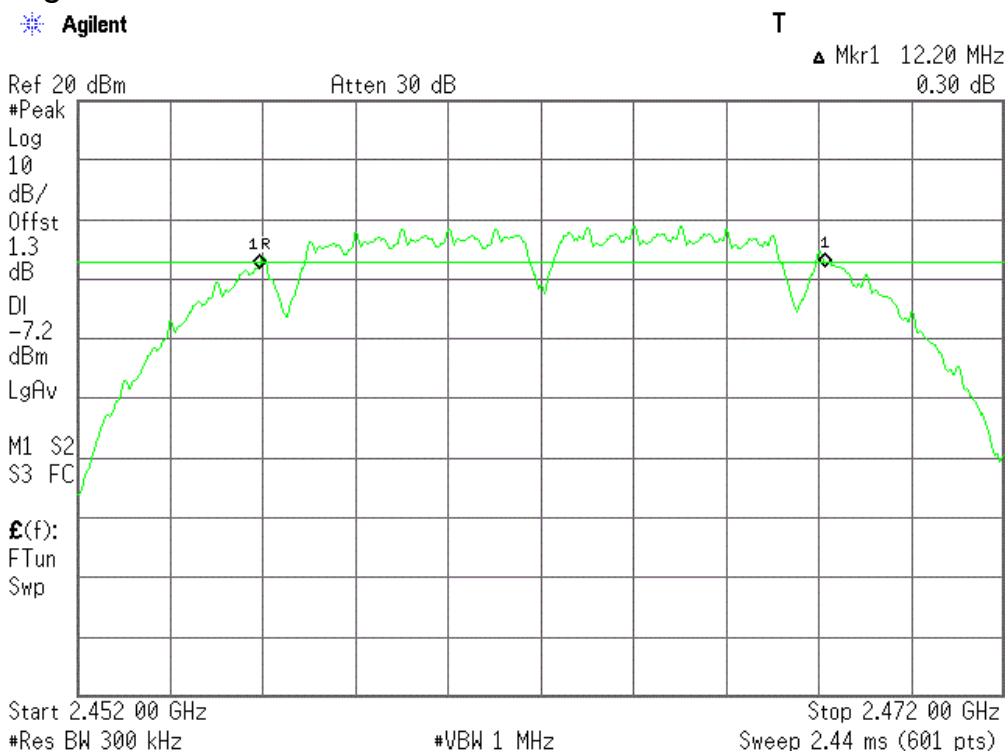

IEEE 802.11g:

CH Low :

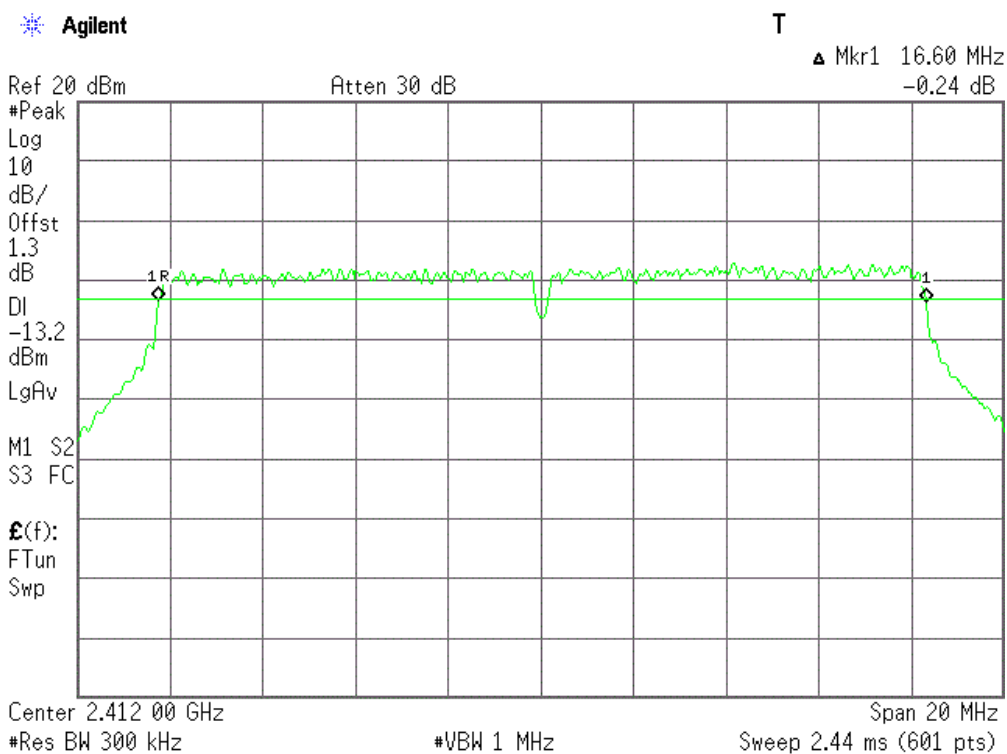

CH Mid :

Agilent

T

Mkr1 16.60 MHz  
-0.43 dB

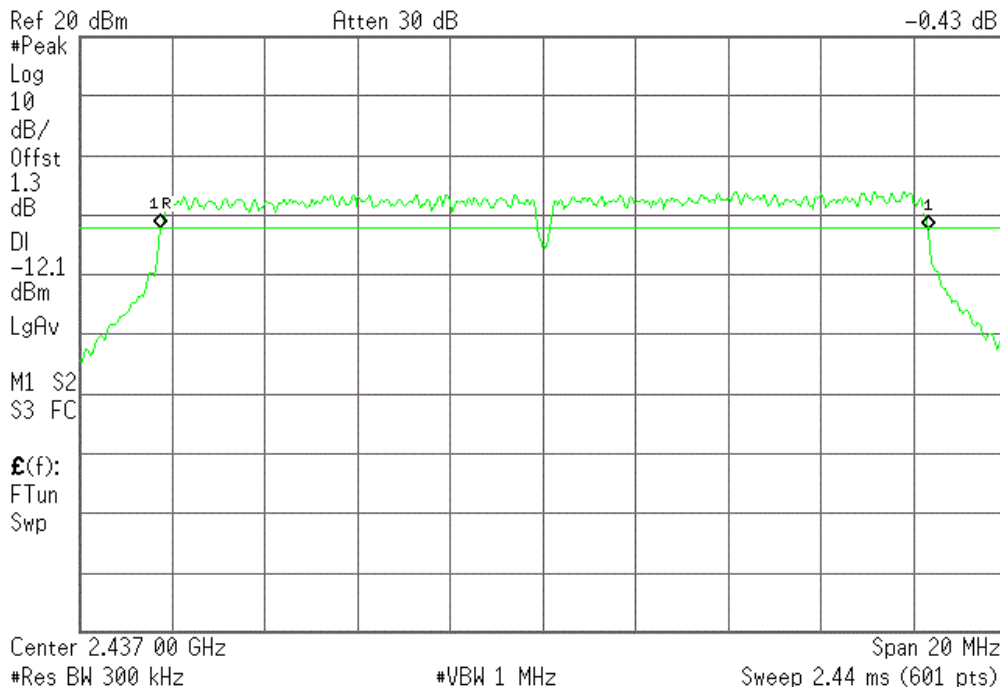

CH High :

Agilent

T

Mkr1 16.60 MHz  
-0.55 dB

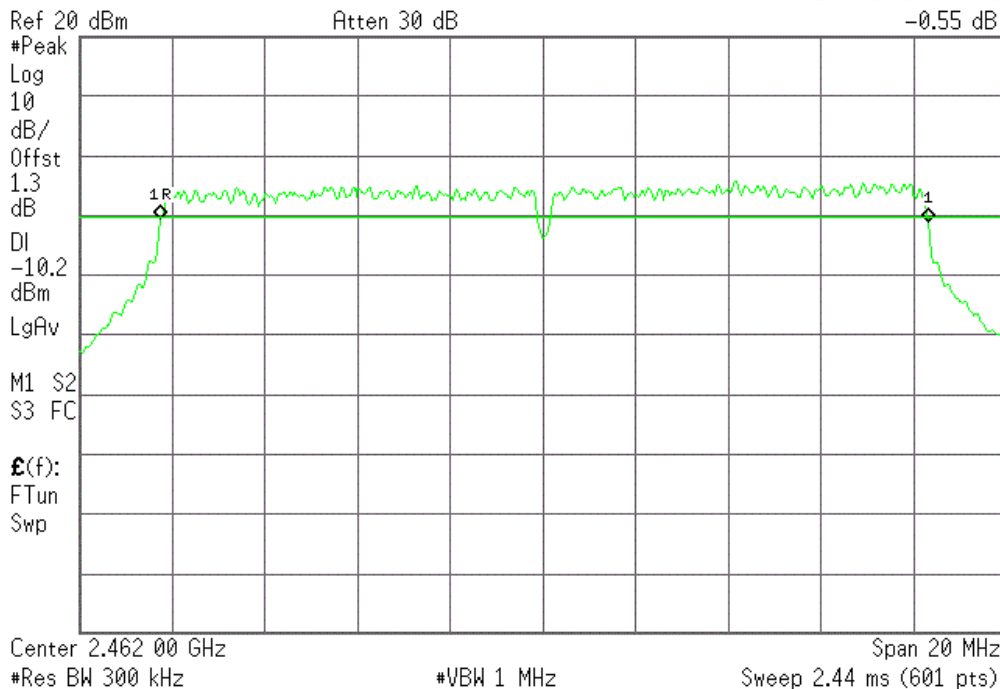

IEEE 802.11n/HT20:

CH Low :

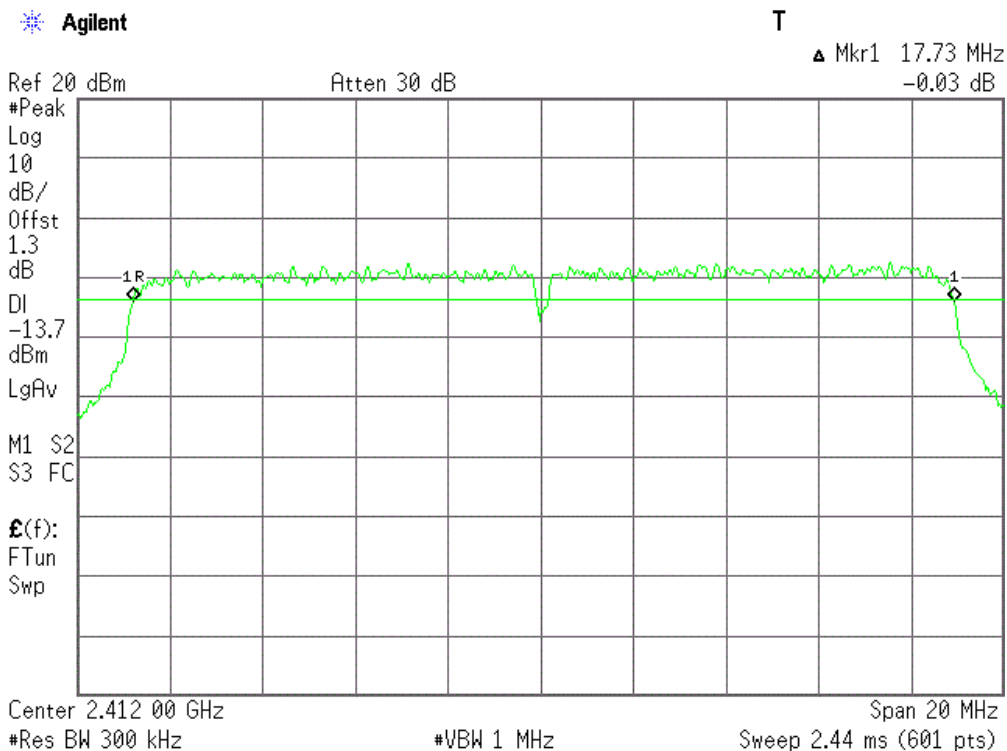

CH Mid :

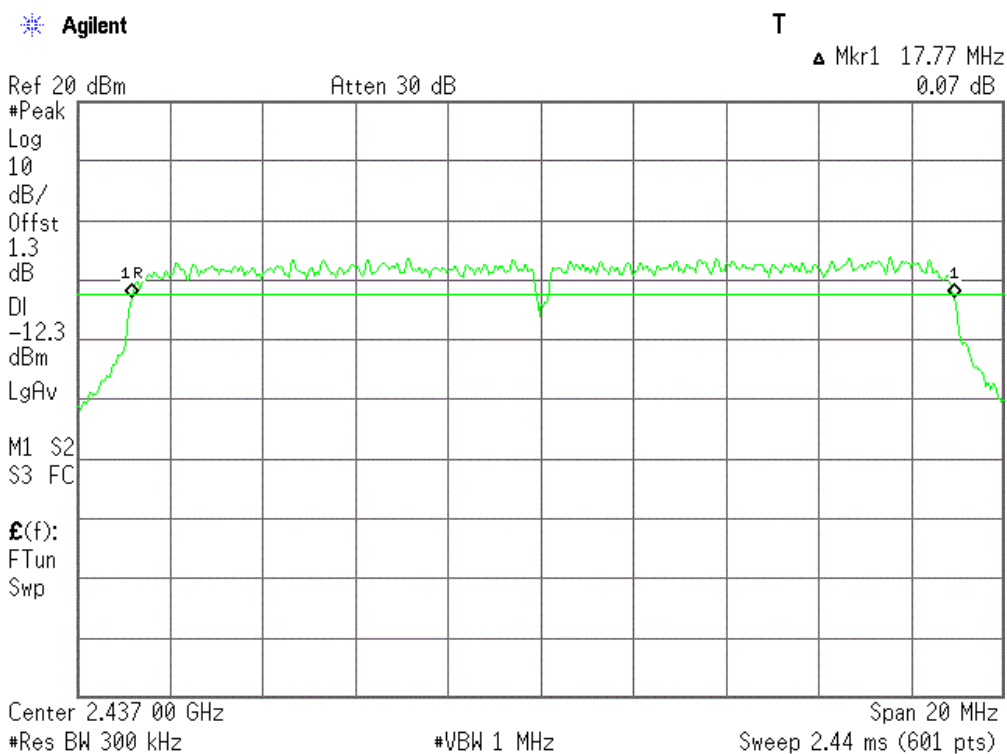



CH High :

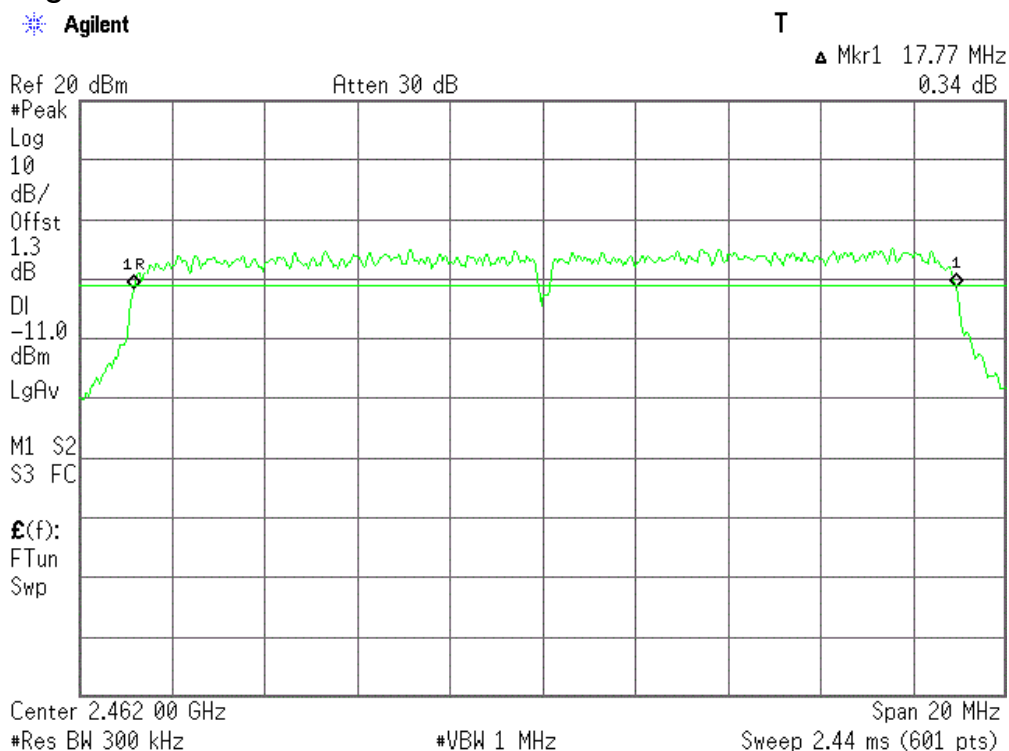

IEEE 802.11n/HT40:

CH Low :

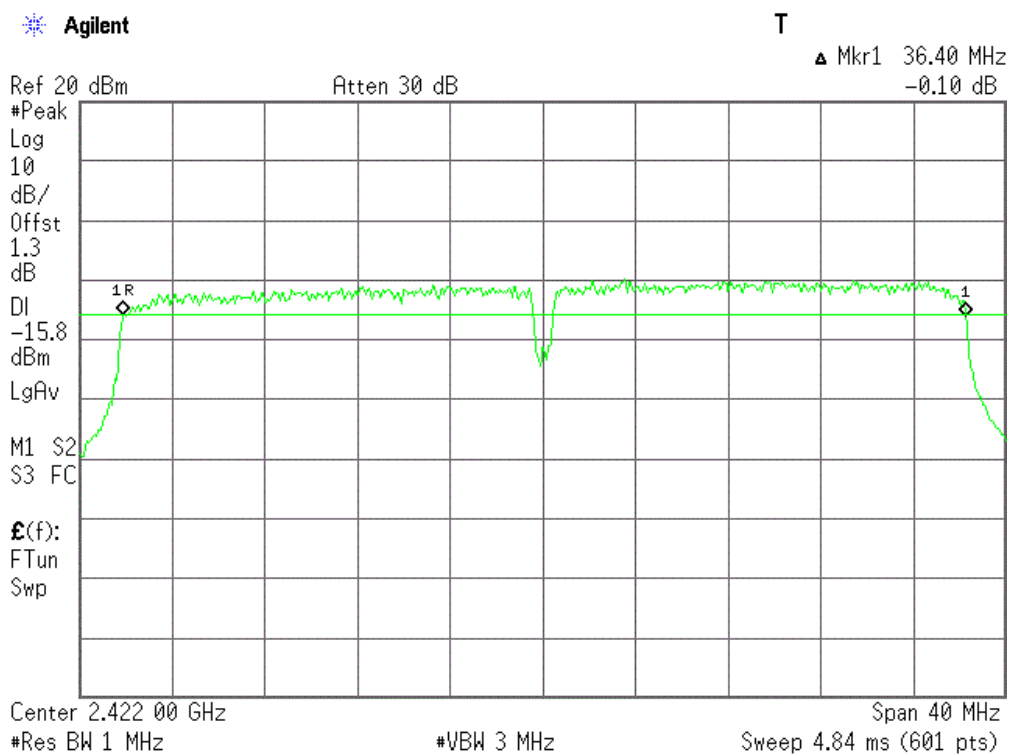

CH Mid :

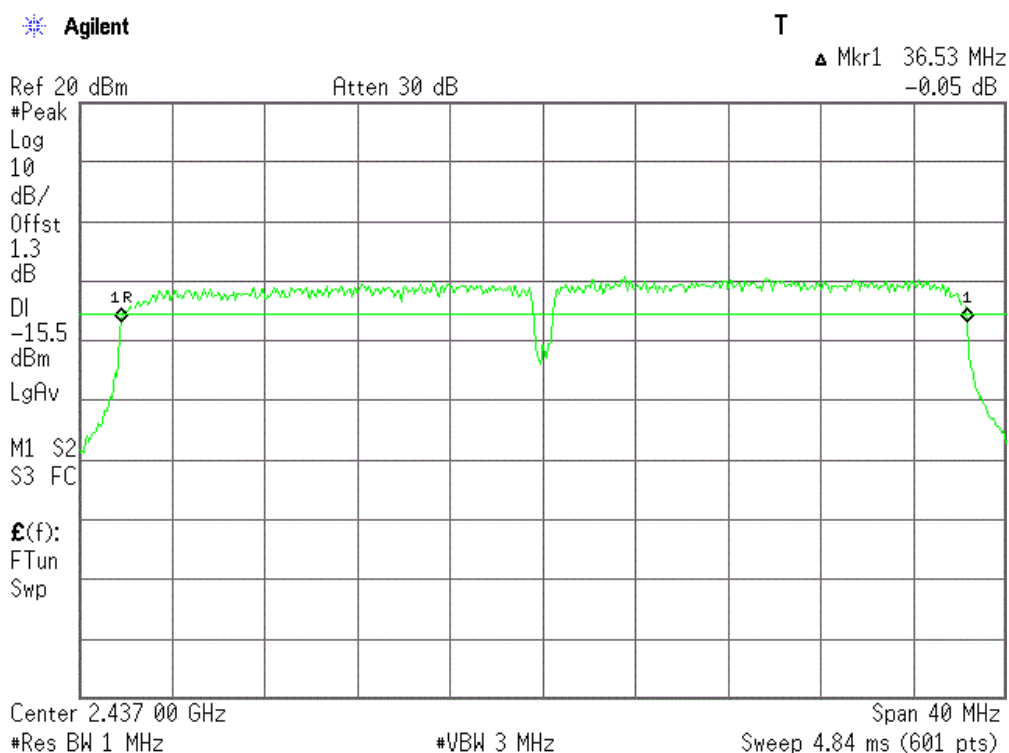

CH High :

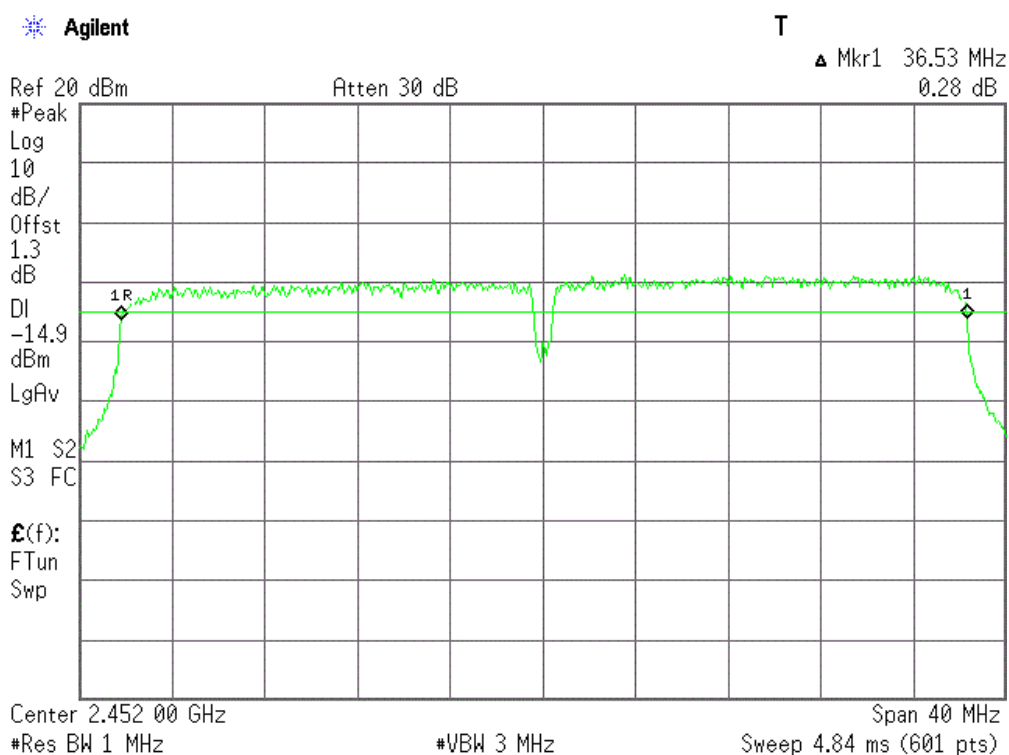

## 10 Band Edge Check

### 10.1 Test limit

Please refer section 15.247

All the lower and upper band-edges emissions appearing within 2310MHz to 2390MHz and 2483.5MHz to 2500MHz restricted frequency bands shall not exceed the limits shown in 15.209, all the other emissions outside operation frequency band 2400MHz to 2483.5MHz shall be at least 20dB below the fundamental emissions, or comply with 15.209 limits.

### 10.2 Test Procedure

12.2.1 Put the EUT on a 0.8m high table, power on the EUT. Emissions were scanned and measured rotating the EUT to 360 degrees, Find the maximum Emission

12.2.2 Check the spurious emissions out of band.

12.2.3 RBW,VBW Setting, please see the following test plot.

### 10.3 Test Setup

Same as 5.2.2.

### 10.4 Test Result

**PASS.**

Detailed information please see the following page.

IEEE 802.11b:

CH LOW :

Detector mode: Peak

Agilent

Polarity: Horizontal

R T

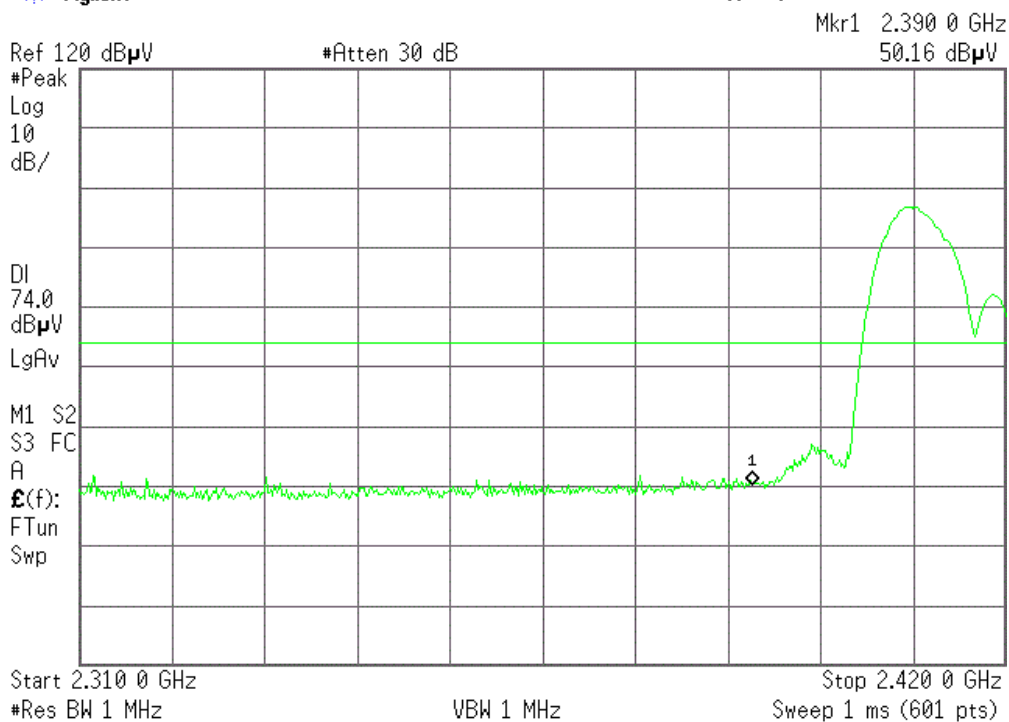

Detector mode: Average

Agilent

Polarity: Horizontal

R T

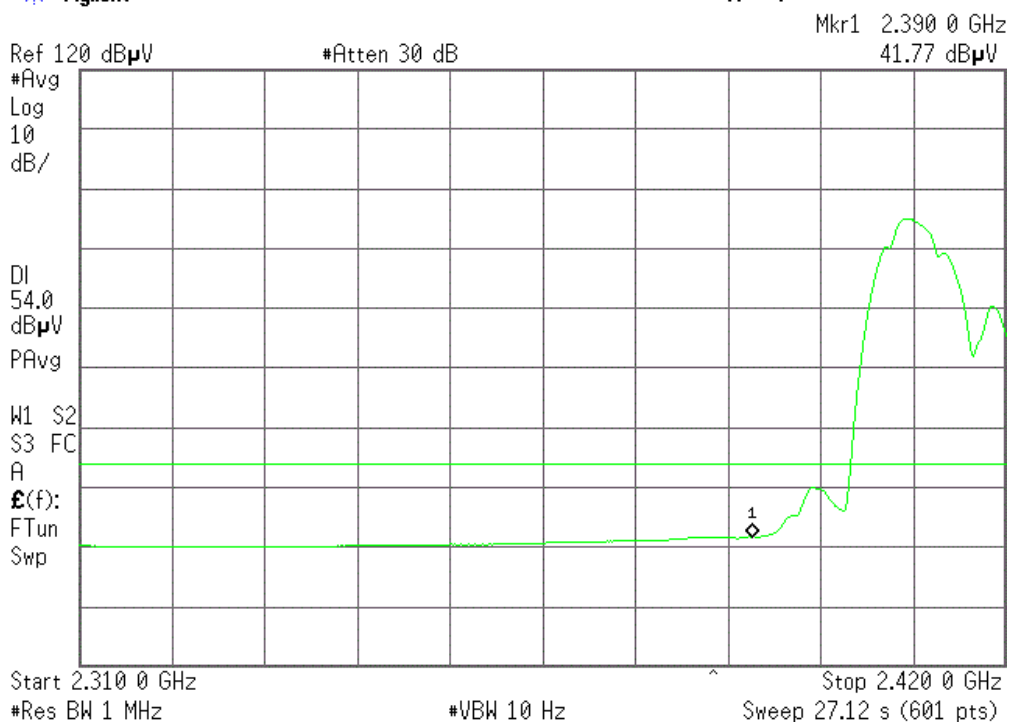

CH High :

Detector mode: Peak

Agilent

Polarity: Horizontal

R T

Mkr1 2.483 50 GHz  
49.69 dB $\mu$ V

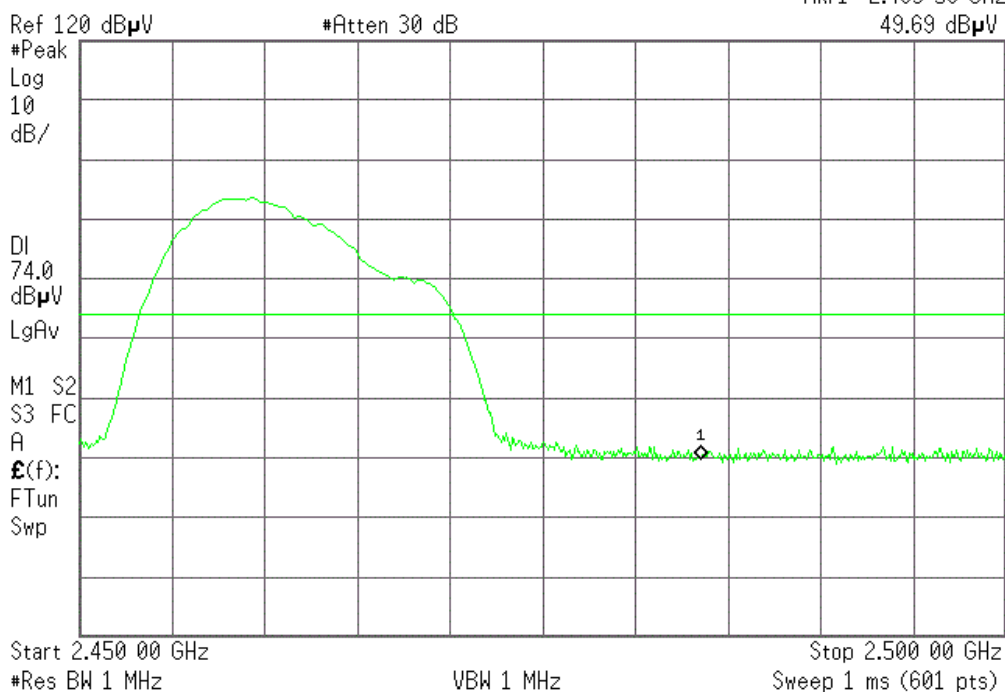

Detector mode: Average

Agilent

Polarity: Horizontal

R T

Mkr1 2.483 50 GHz  
41.19 dB $\mu$ V

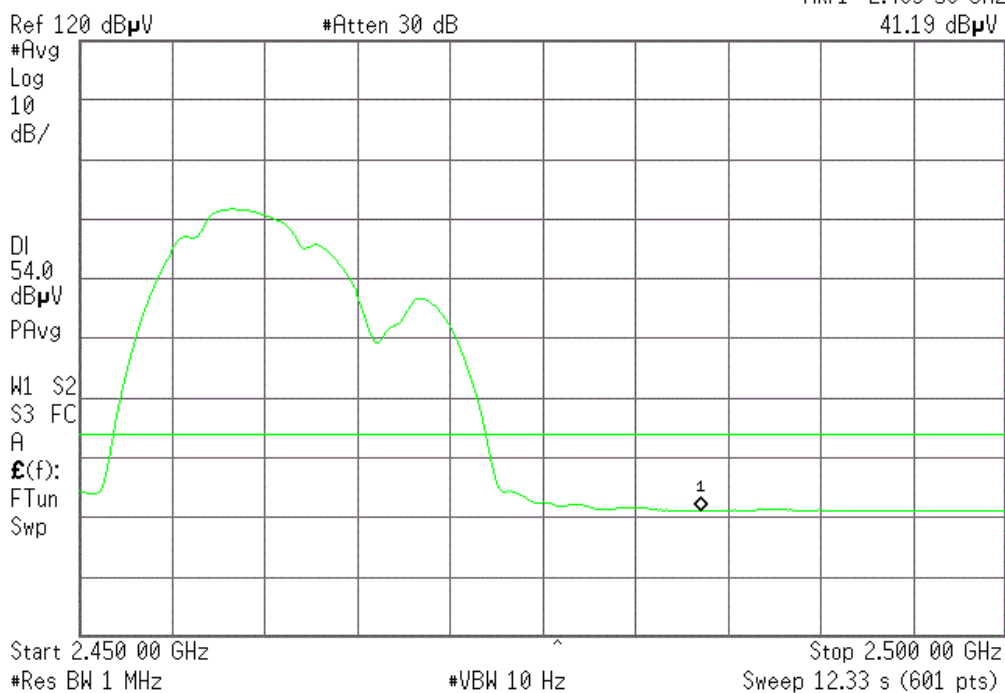

CH LOW :

Detector mode: Peak

Polarity: Vertical

Agilent

R T

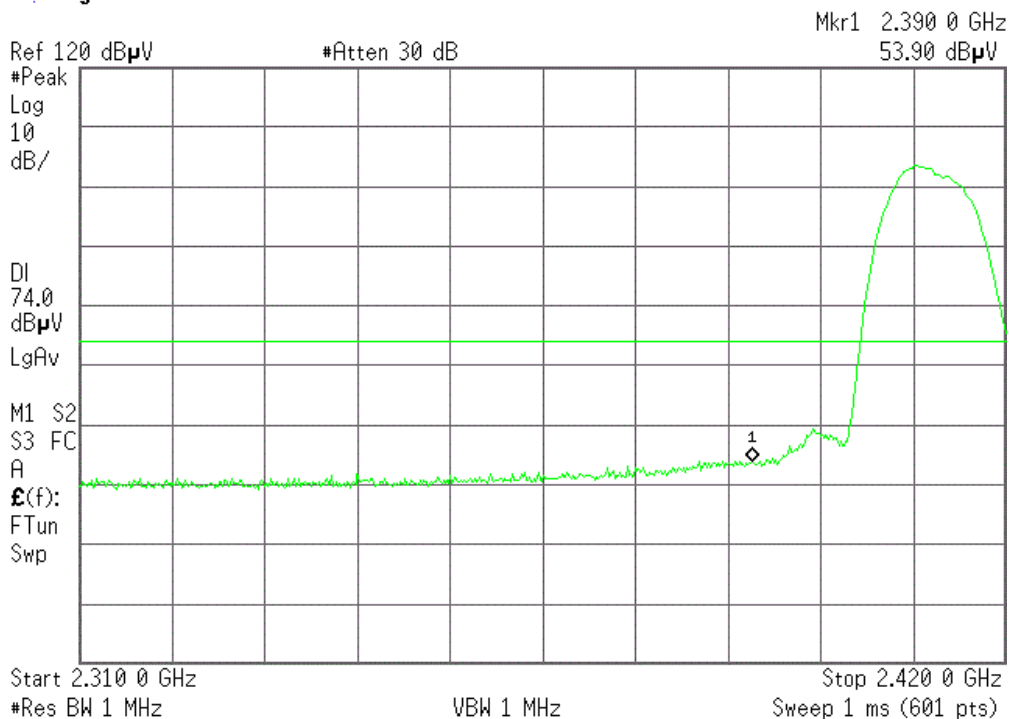

Detector mode: Average

Polarity: Vertical

Agilent

R T

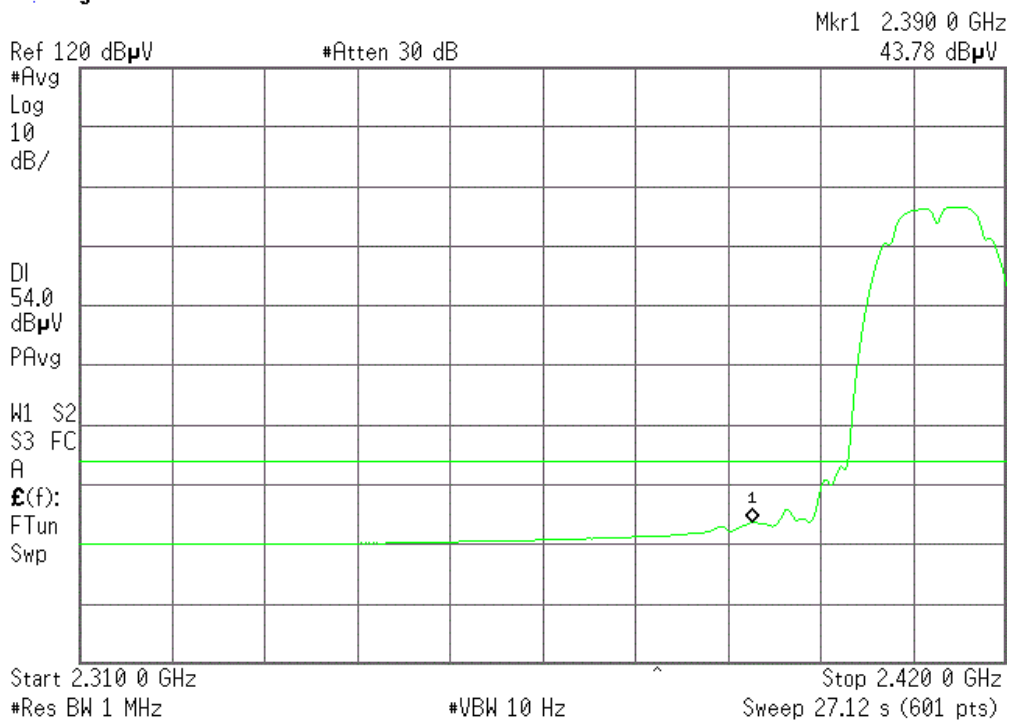

CH High :

Detector mode: Peak

Agilent

Polarity: Vertical

R T

Mkr1 2.483 50 GHz

55.66 dB $\mu$ V

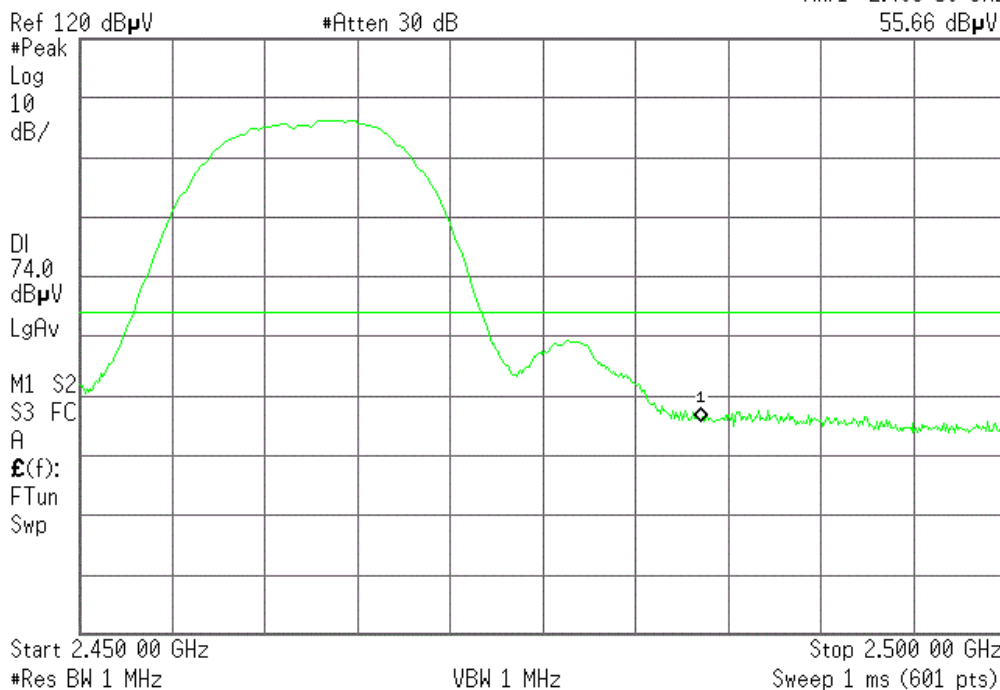

Detector mode: Average

Agilent

Polarity: Vertical

R T

Mkr1 2.483 50 GHz

46.92 dB $\mu$ V

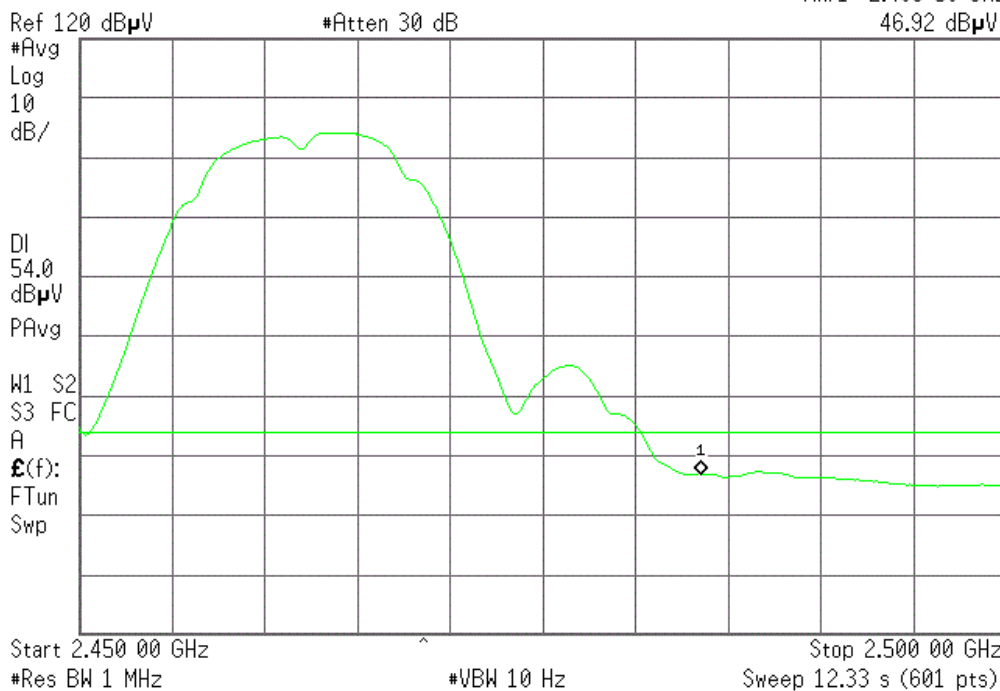

IEEE 802.11g:

CH LOW :

Detector mode: Peak

Agilent

Polarity: Horizontal

R T

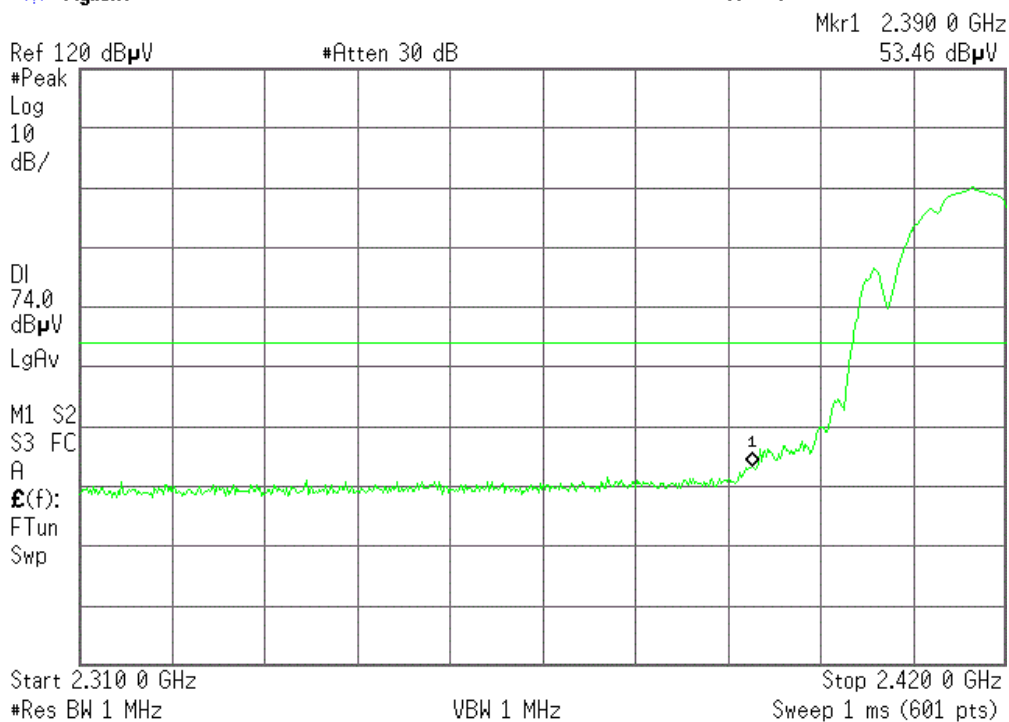

Detector mode: Average

Agilent

Polarity: Horizontal

R T

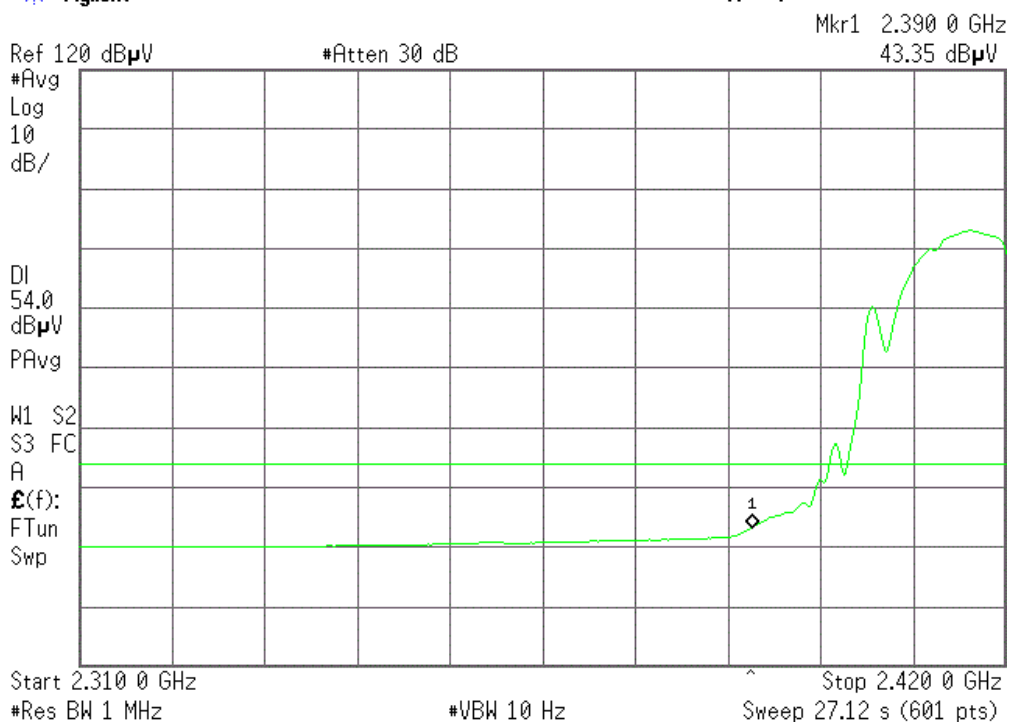



CH High :

Detector mode: Peak

Agilent

Polarity: Horizontal

R T

Mkr1 2.483 50 GHz  
50.54 dB $\mu$ V

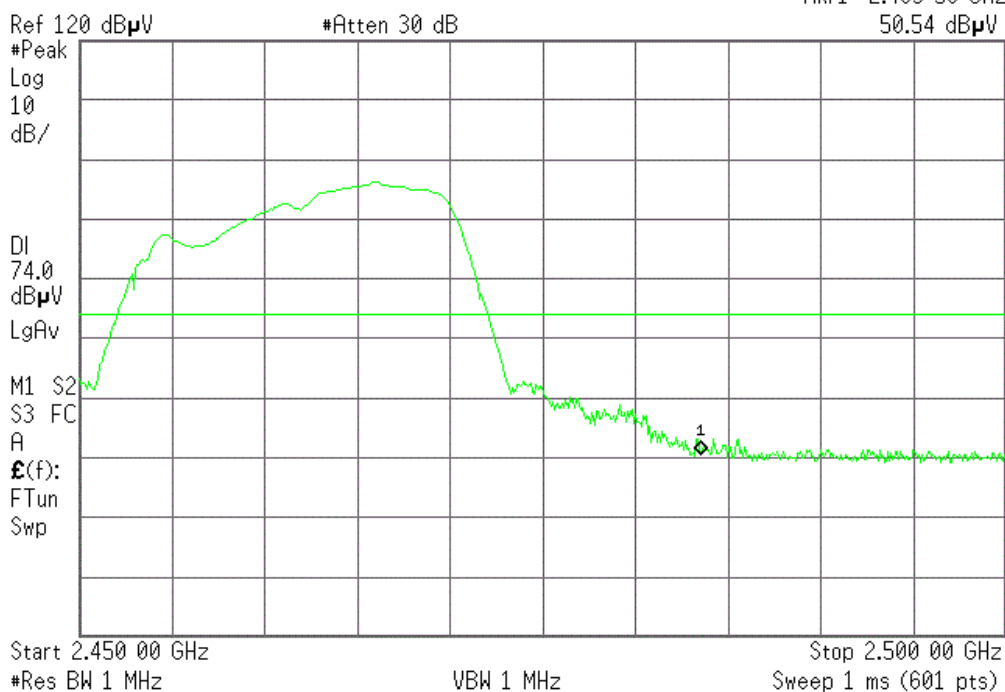

Detector mode: Average

Agilent

Polarity: Horizontal

R T

Mkr1 2.483 50 GHz  
41.65 dB $\mu$ V

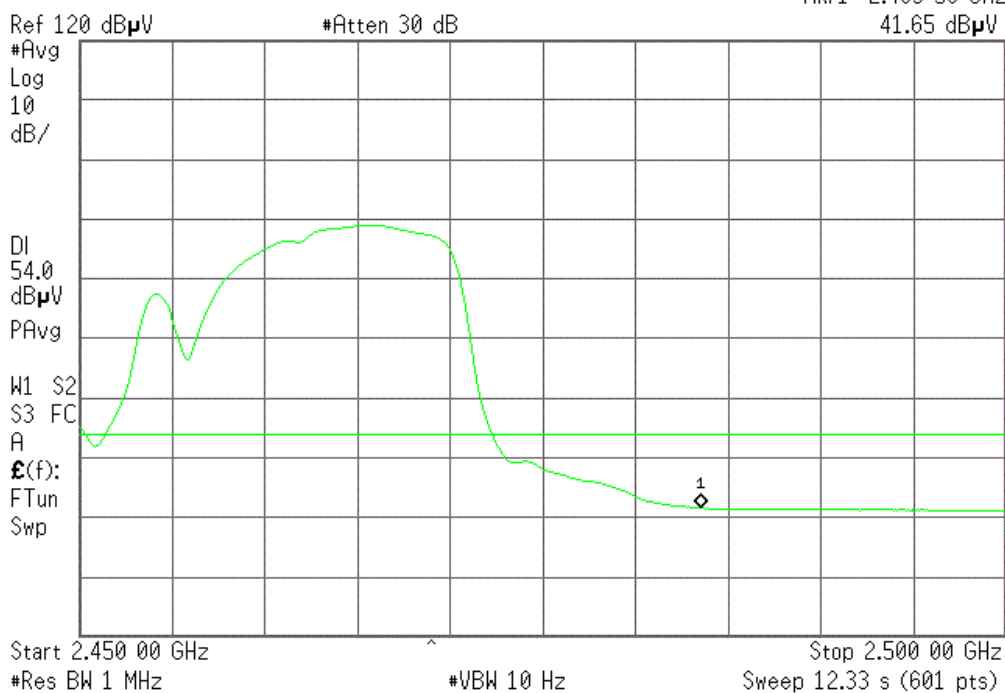

CH LOW :

Detector mode: Peak

Polarity: Vertical

Agilent

R T

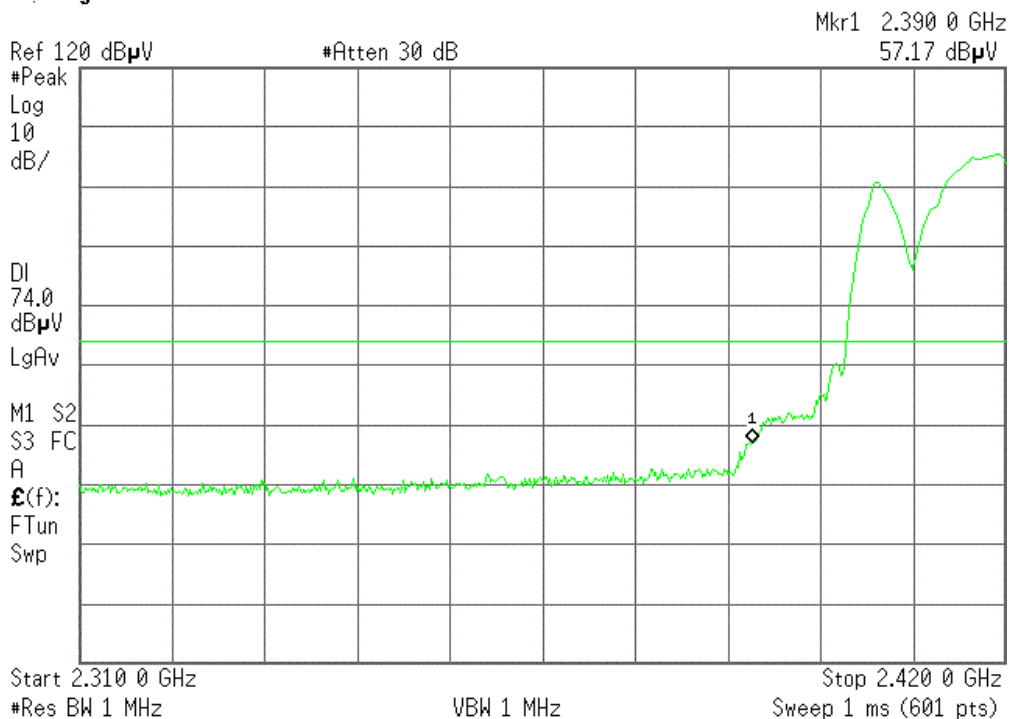

Detector mode: Average

Polarity: Vertical

Agilent

R T

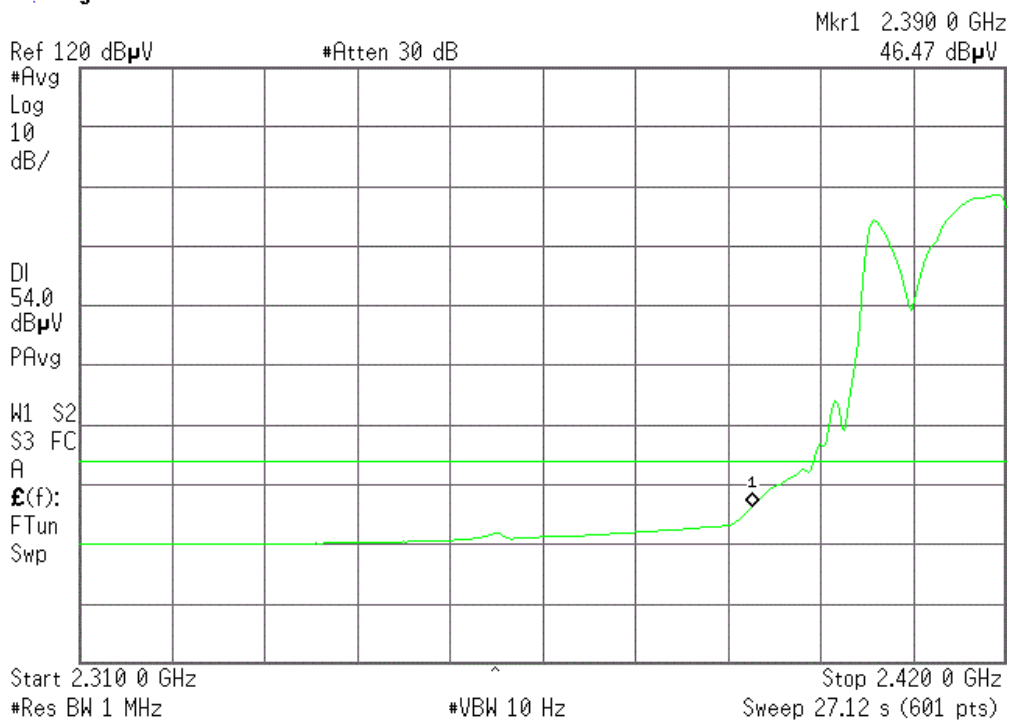

CH High :

Detector mode: Peak

Agilent

Polarity: Vertical

R T

Mkr1 2.483 50 GHz

56.24 dB $\mu$ V

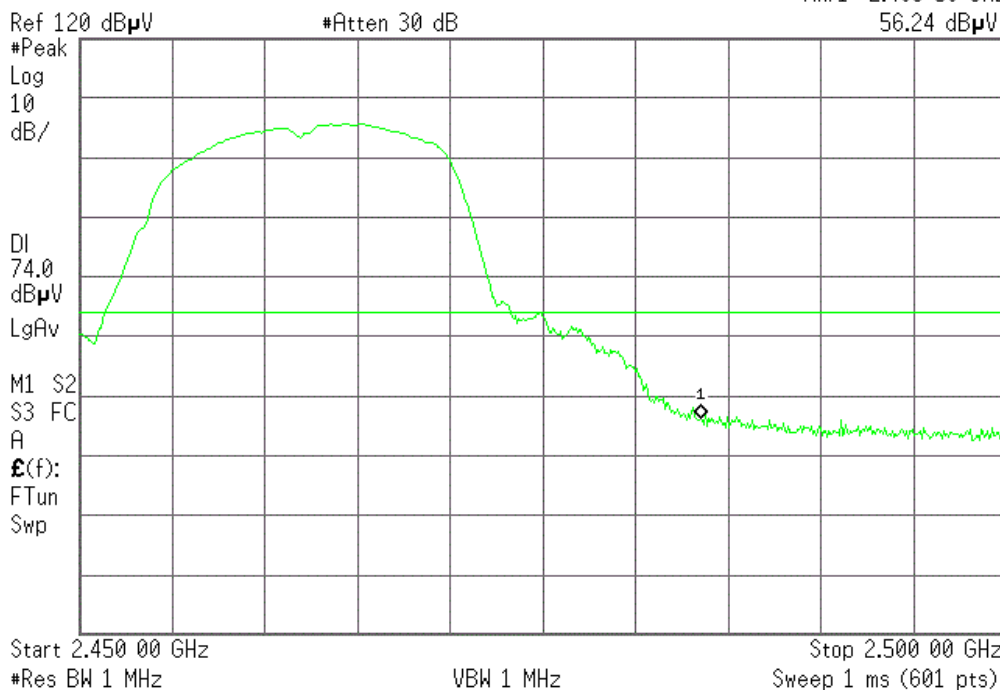

Detector mode: Average

Agilent

Polarity: Vertical

R T

Mkr1 2.483 50 GHz

46.90 dB $\mu$ V

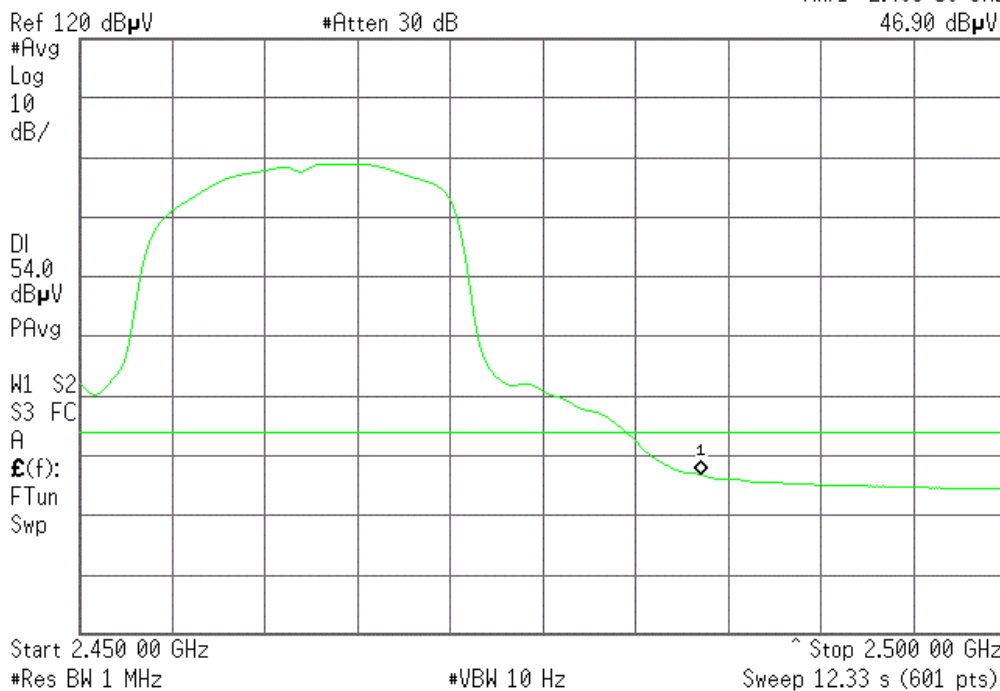

IEEE 802.11n/HT20:

CH LOW :

Detector mode: Peak

Agilent

Polarity: Horizontal

R T

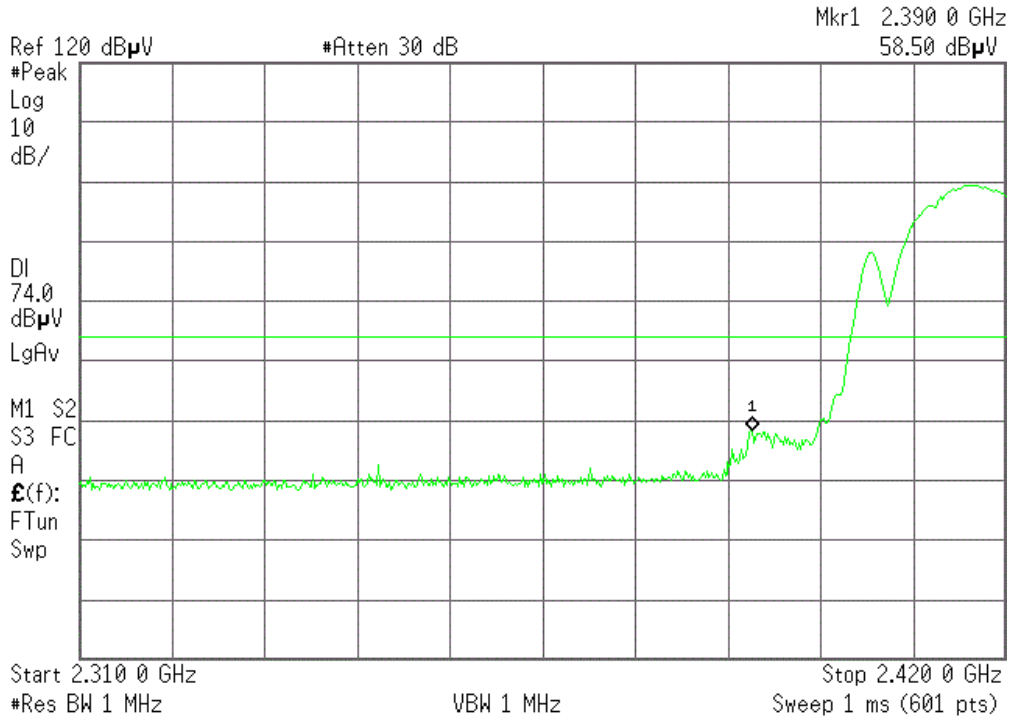

Detector mode: Average

Agilent

Polarity: Horizontal

R T

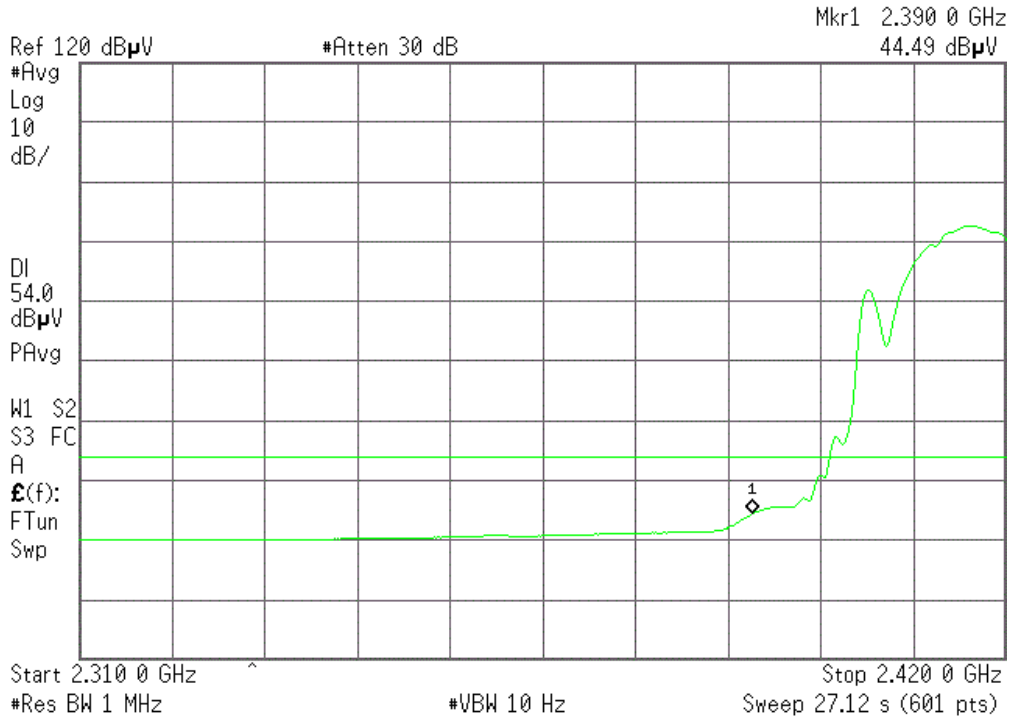

CH High :

Detector mode: Peak

Agilent

Polarity: Horizontal

R T

Mkr1 2.483 50 GHz  
52.81 dB $\mu$ V

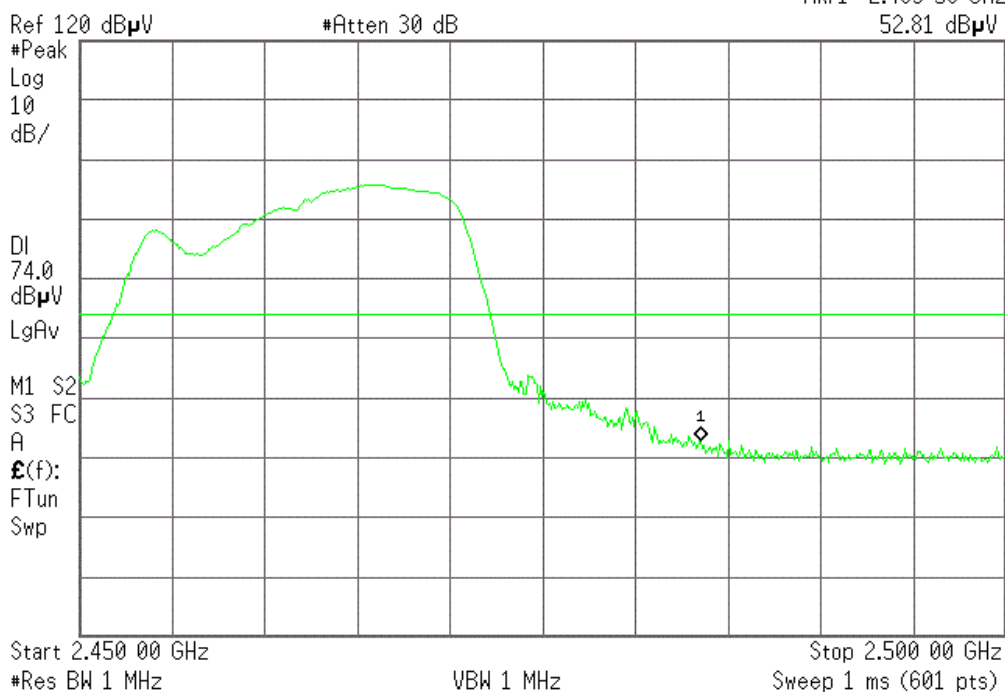

Detector mode: Average

Agilent

Polarity: Horizontal

R T

Mkr1 2.483 50 GHz  
42.21 dB $\mu$ V

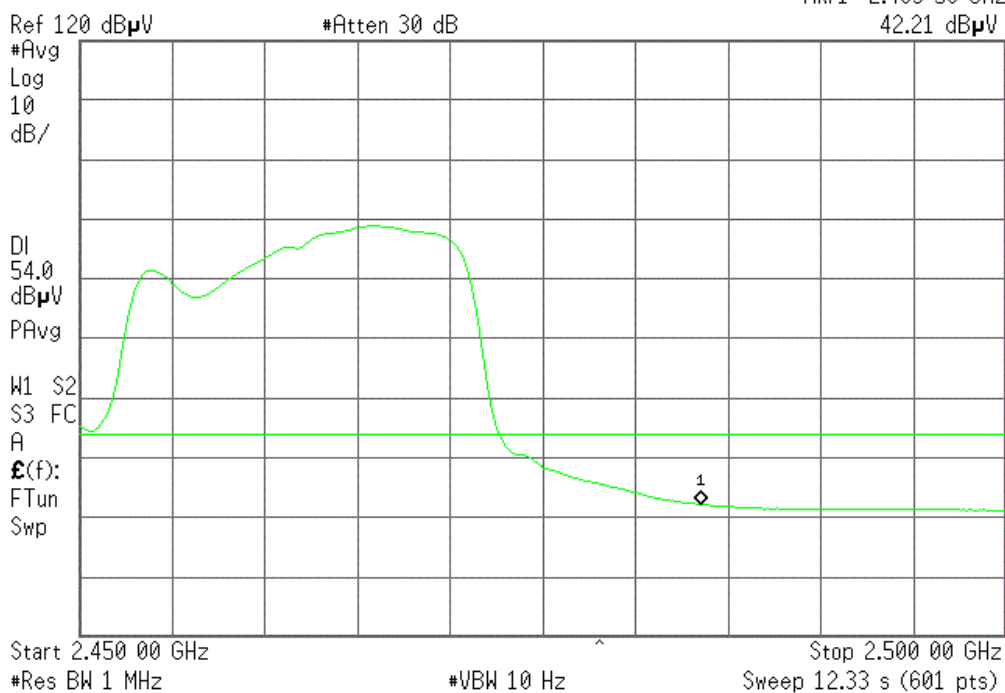

CH LOW :

Detector mode: Peak

Agilent

Polarity: Vertical

R T

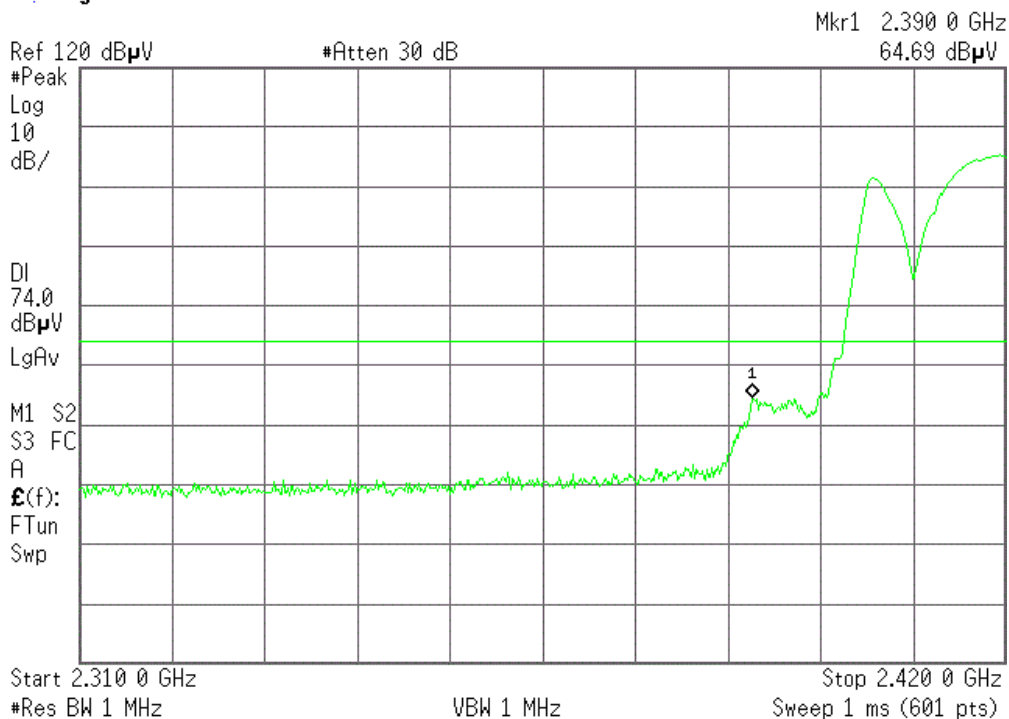

Detector mode: Average

Agilent

Polarity: Vertical

R T

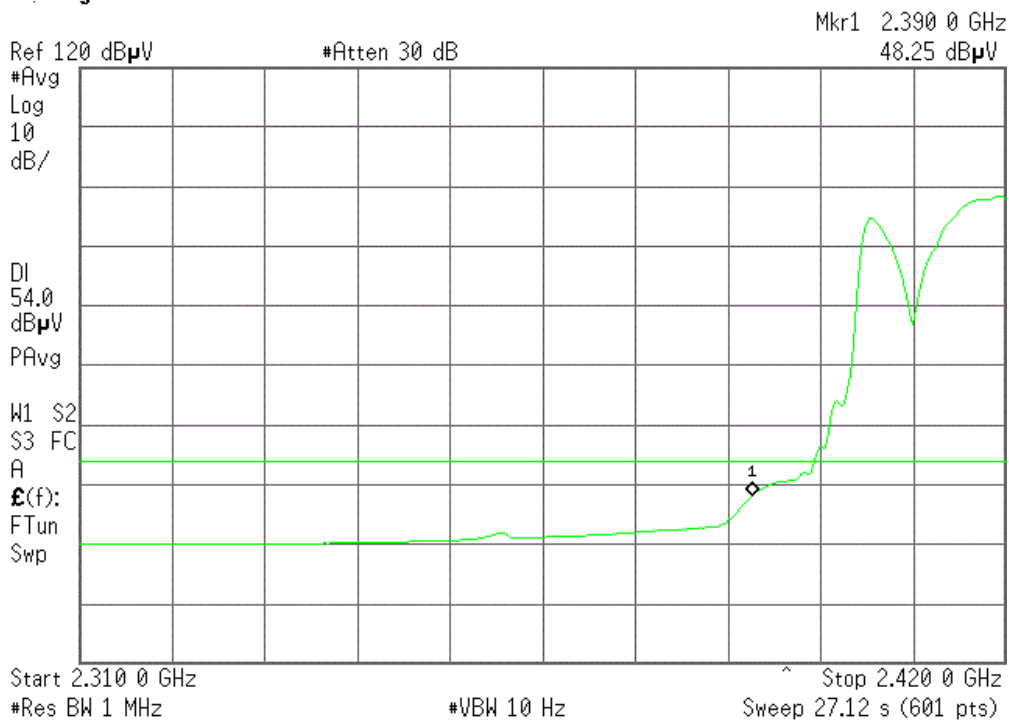

CH High :

Detector mode: Peak

Agilent

Polarity: Vertical

R T

Mkr1 2.483 50 GHz

56.18 dB $\mu$ V

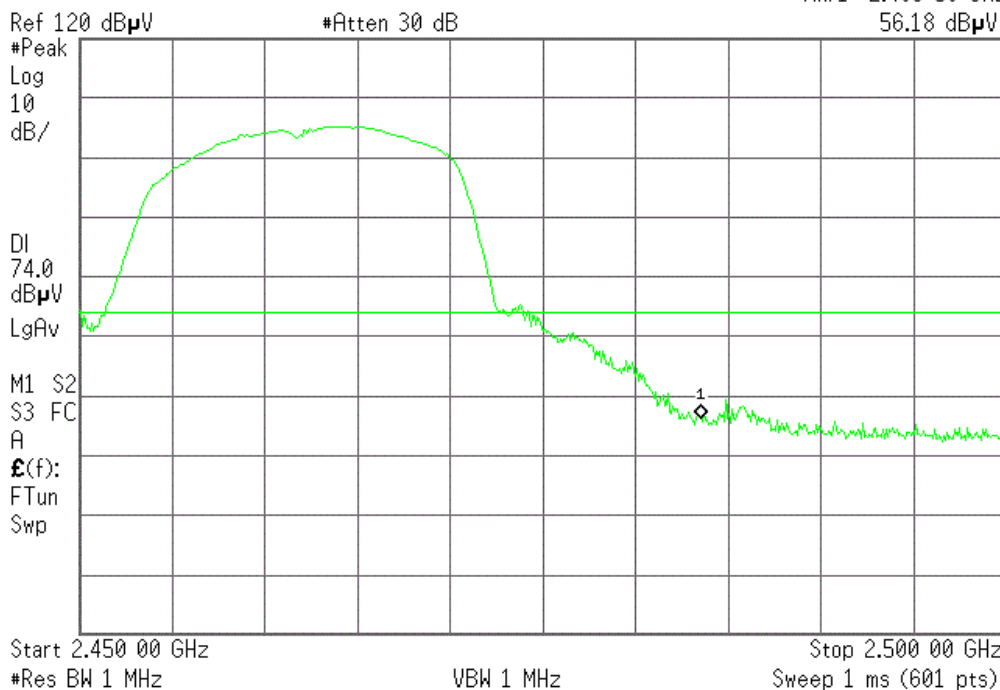

Detector mode: Average

Agilent

Polarity: Vertical

R T

Mkr1 2.483 50 GHz

46.83 dB $\mu$ V

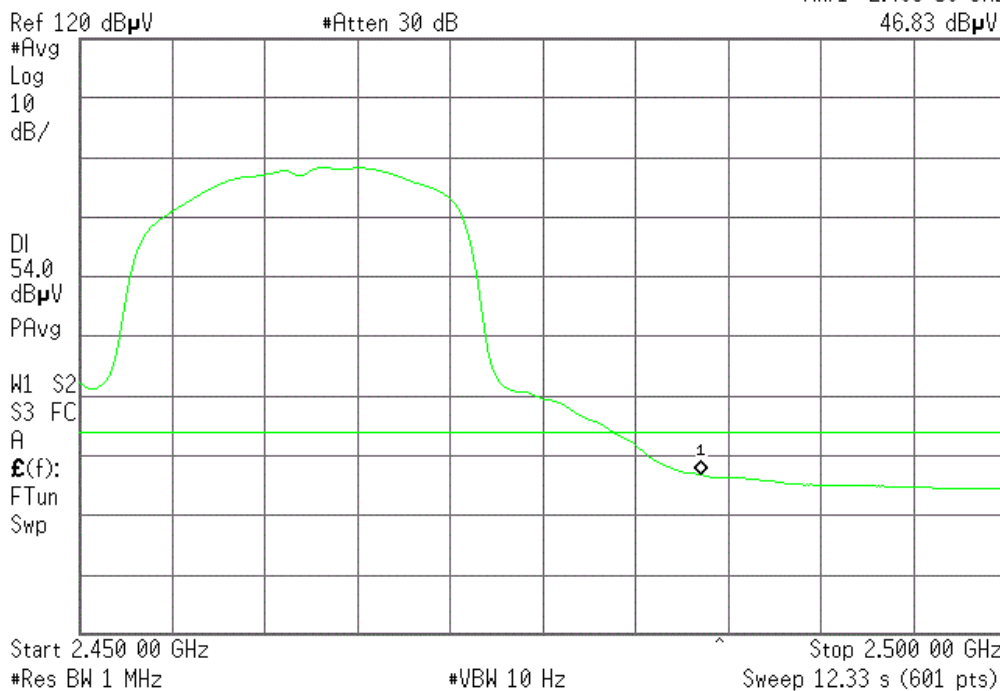

IEEE 802.11n/HT40:

CH LOW :

Detector mode: Peak

Polarity: Horizontal

Agilent

R L

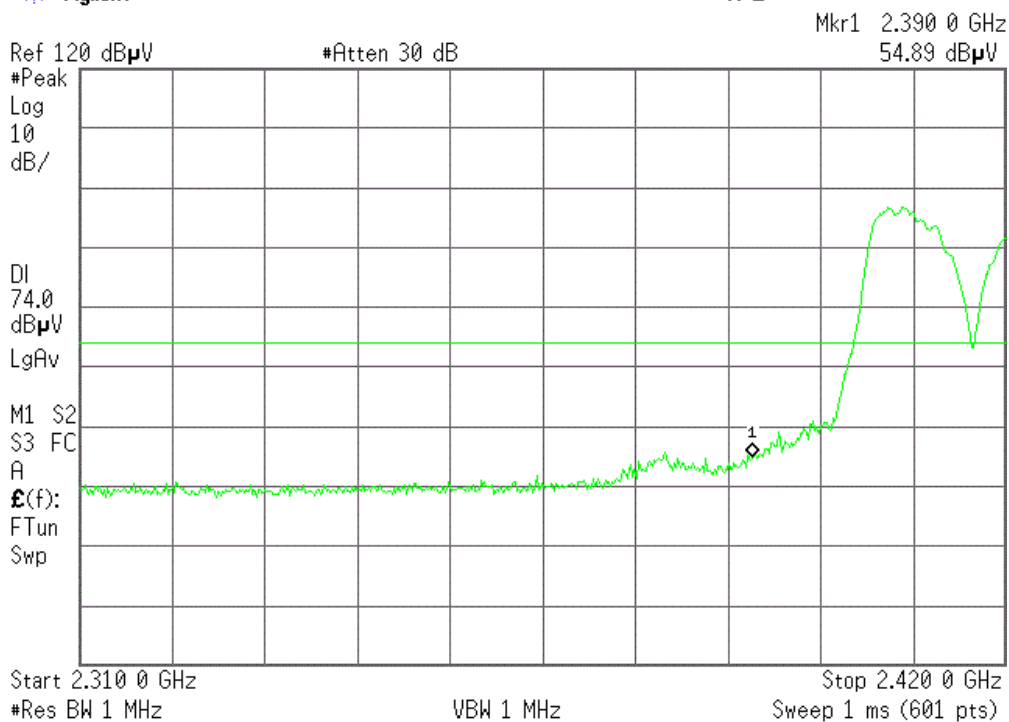

Detector mode: Average

Polarity: Horizontal

Agilent

R T

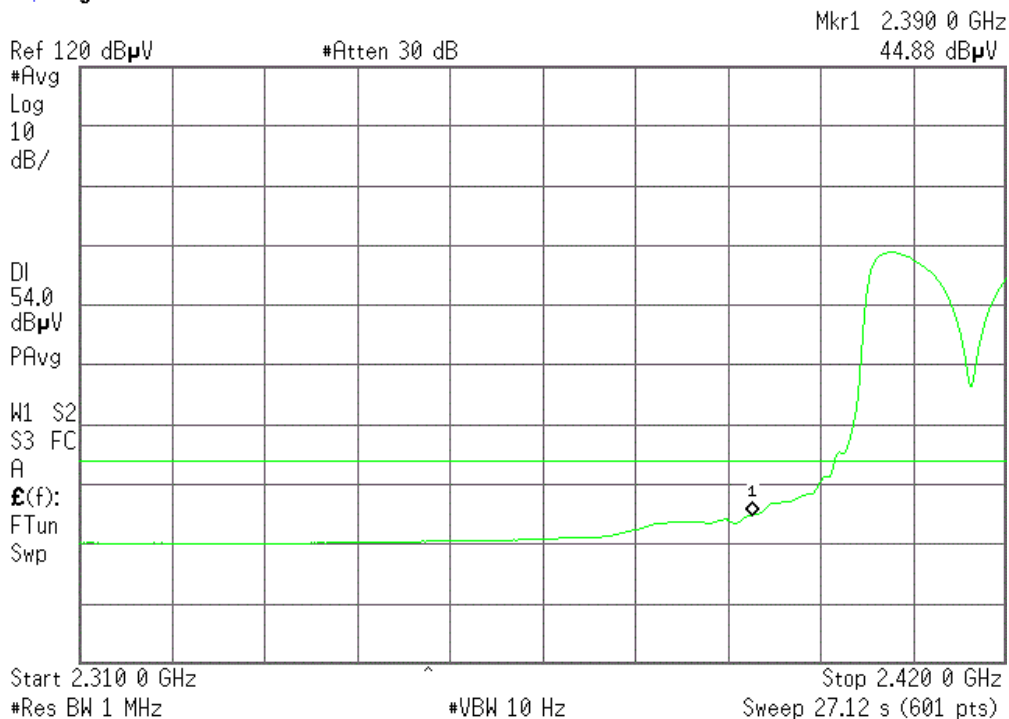



CH High :

Detector mode: Peak

Agilent

Polarity: Horizontal

R T

Mkr1 2.483 50 GHz  
54.09 dB $\mu$ V

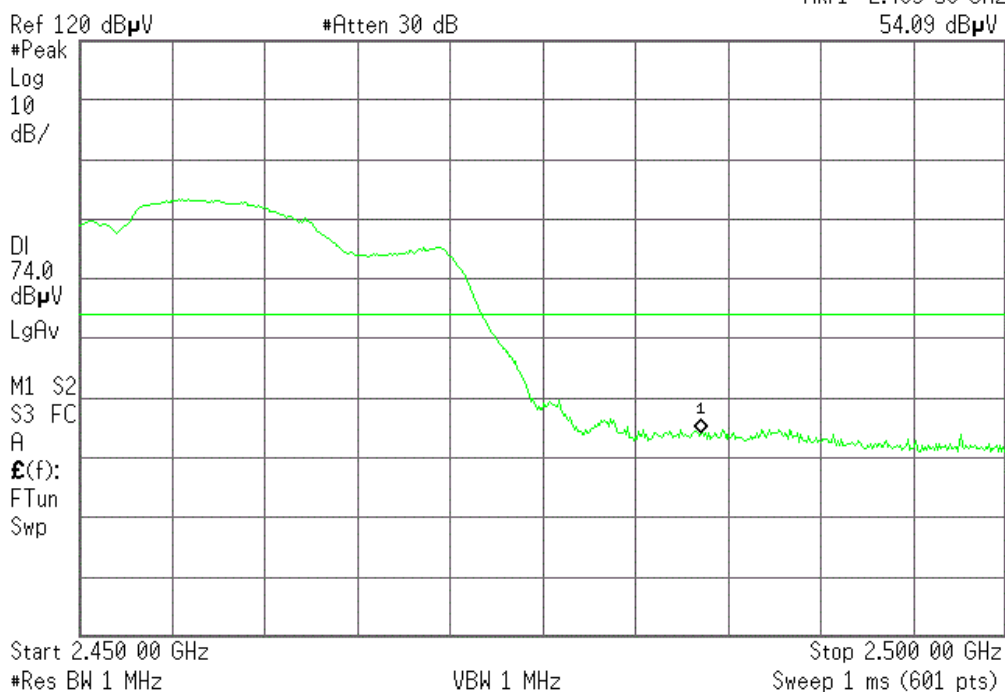

Detector mode: Average

Agilent

Polarity: Horizontal

R T

Mkr1 2.483 50 GHz  
43.36 dB $\mu$ V

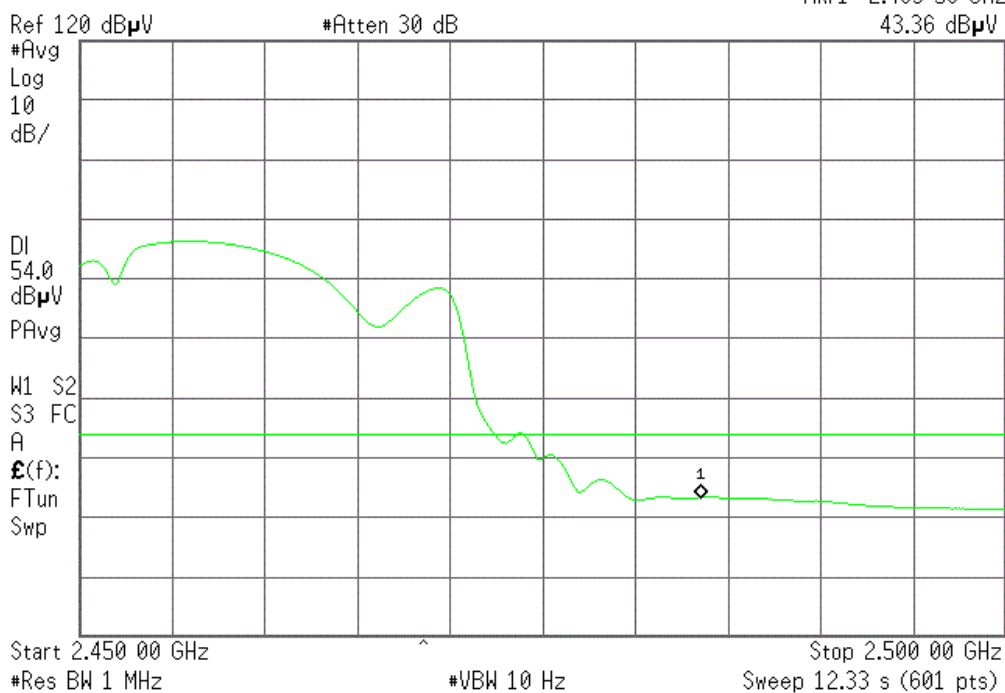

CH LOW :

Detector mode: Peak

Polarity: Vertical

Agilent

R T

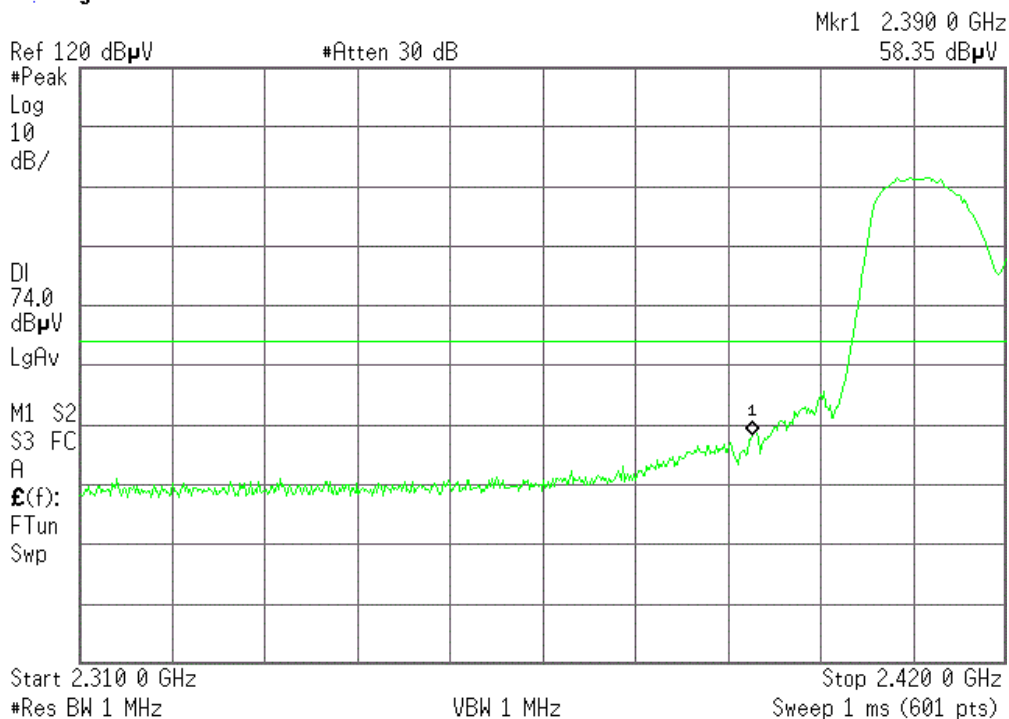

Detector mode: Average

Polarity: Vertical

Agilent

R T



CH High :

Detector mode: Peak

Agilent

Polarity: Vertical

R T

Mkr1 2.483 50 GHz

63.15 dB $\mu$ V

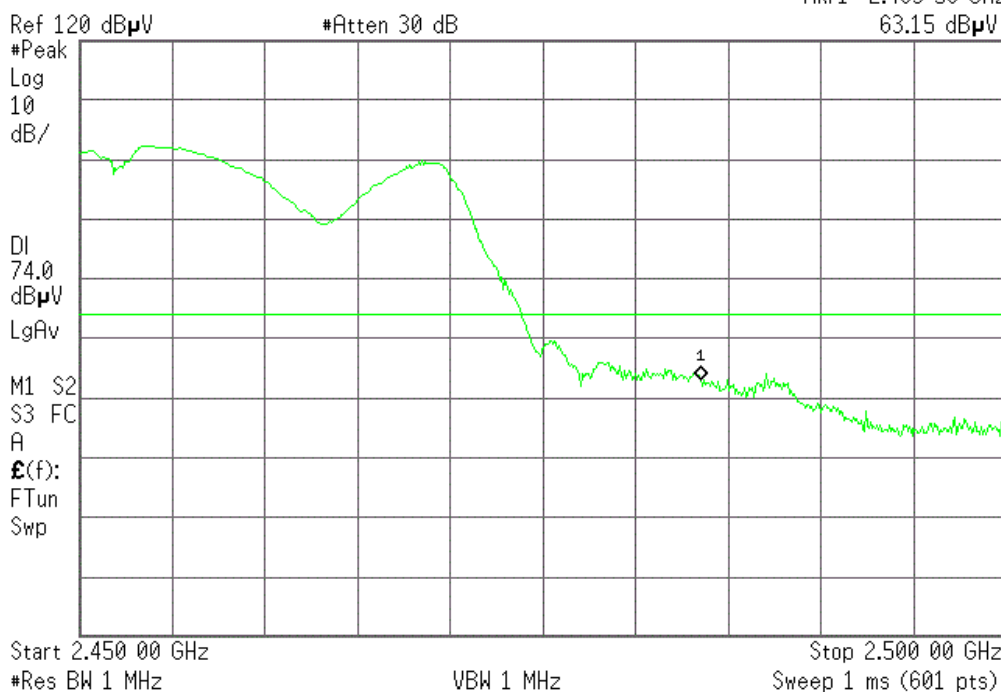

Detector mode: Average

Agilent

Polarity: Vertical

R T

Mkr1 2.483 50 GHz

53.06 dB $\mu$ V

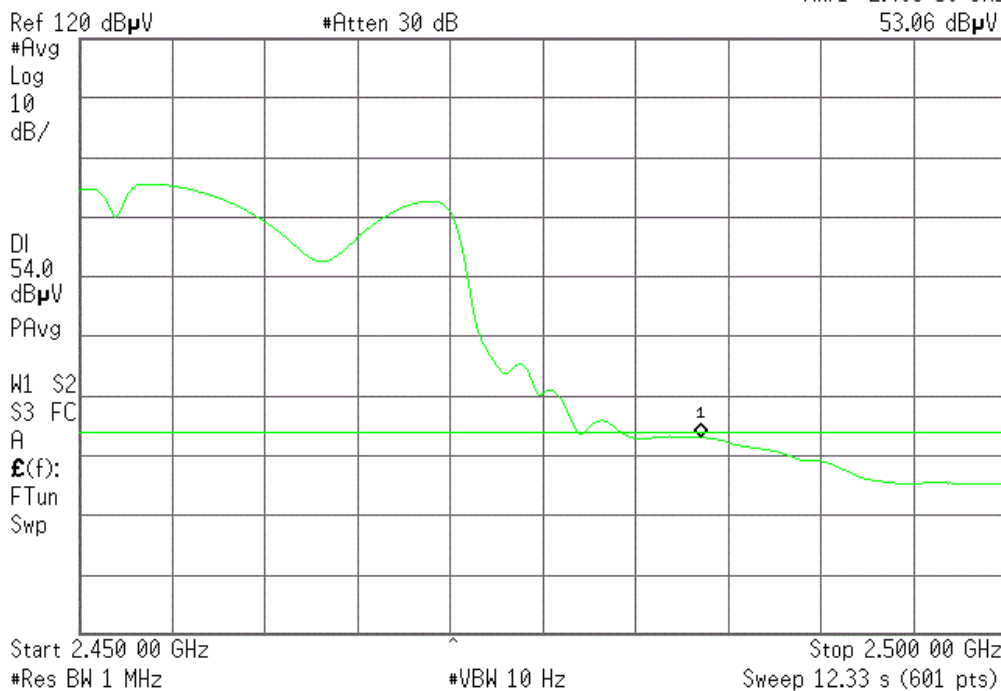

## 11 Antenna Requirement

### 11.1 Standard Requirement

An intentional radiator shall be designed to ensure that no antenna other than that furnished by the responsible party shall be used with the device. The use of a permanently attached antenna or of an antenna that uses a unique coupling to the intentional radiator shall be considered sufficient to comply with the provisions of this Section. The manufacturer may design the unit so that a broken antenna can be replaced by the user, but the use of a standard antenna jack or electrical connector is prohibited.

### 11.2 Antenna Connected Construction

The directional gains of antenna used for transmitting is 0 dBi, and the antenna connector is designed with permanent attachment and no consideration of replacement. Please see EUT photo for details.

### 11.3 Result

The EUT antenna is integral Antenna. It comply with the standard requirement.

## 12 Photographs of Test Setup

### Photographs-Radiated Emission Test Setup in Chamber

Below 1G

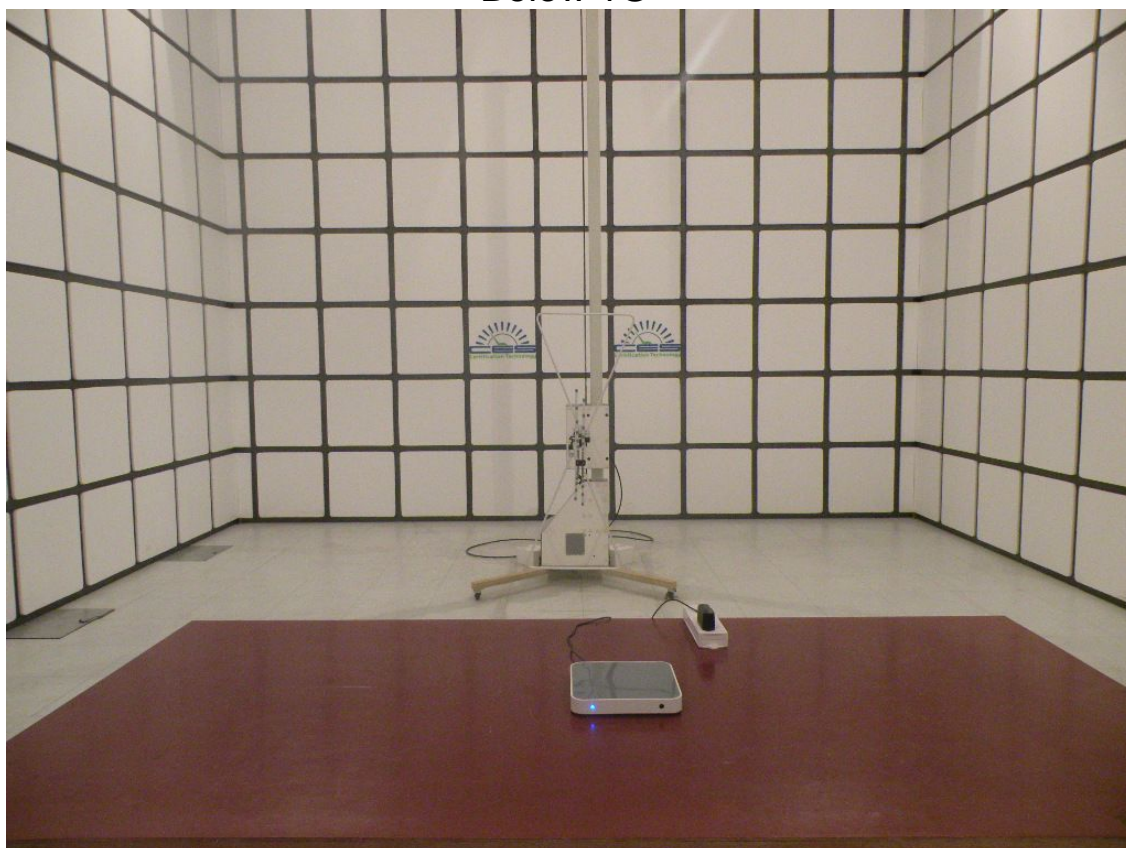





Above 1G

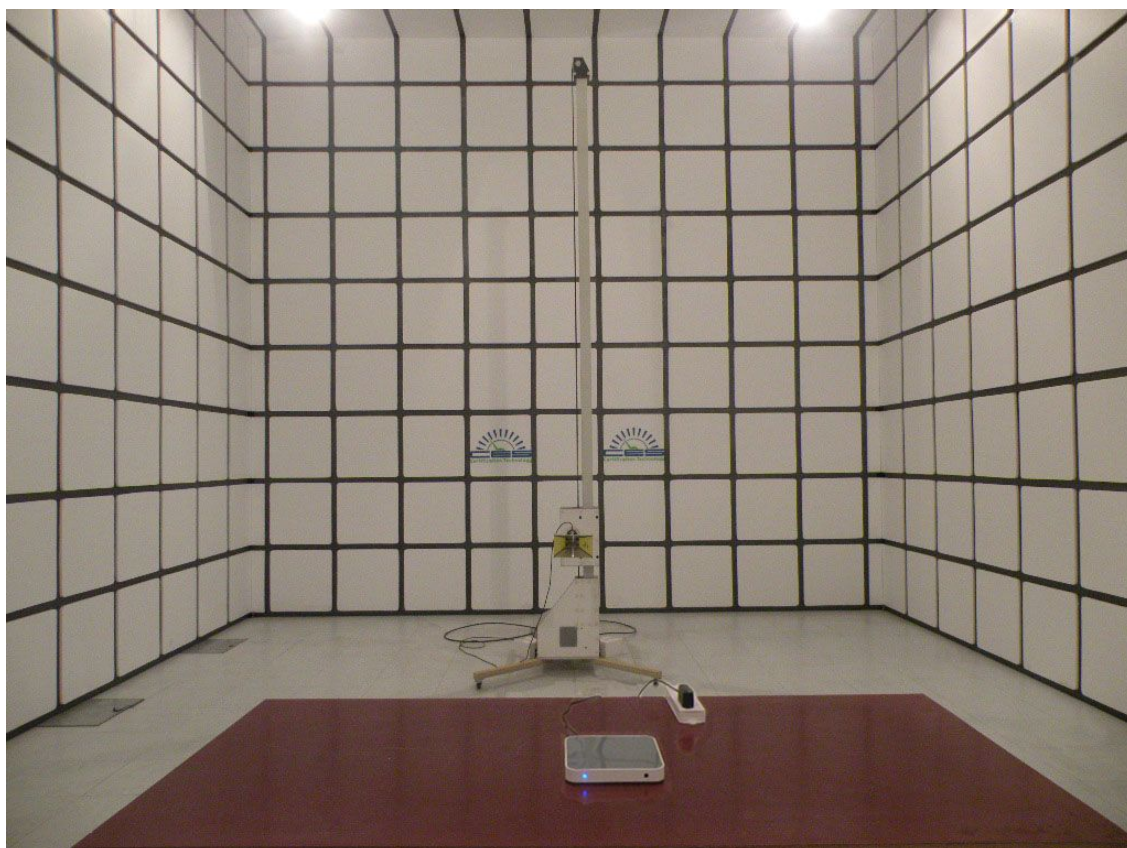

## Photographs-Conducted Emission Test Setup







## 13 Photographs of EUT

**Figure 1**

Photo of EUT

Front View [ ]

Rear View [ ]

Full View [  ]

Bottom View [ ]

Left View [ ]

Right View [ ]

Full View [ ]

A photograph of a grey, square-shaped electronic device with rounded corners, placed on a blue surface. To the left of the device is a vertical ruler, and below it is a horizontal ruler. To the right of the device is a black power adapter with a coiled cable. The device is centered between the two rulers.

**Figure 2**

Photo of EUT

Front View [ ]

Rear View [ ]

Top View [  ]

Bottom View [ ]

Left View [ ]

Right View [ ]

Full View [ ]

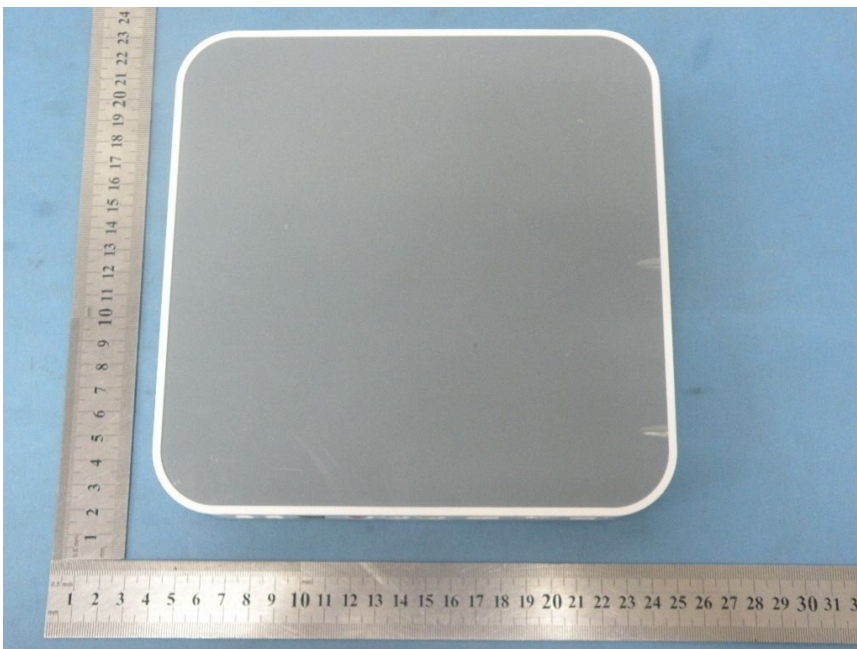
A photograph of the same grey, square-shaped electronic device with rounded corners, placed on a blue surface. To the left of the device is a vertical ruler, and below it is a horizontal ruler. The device is centered between the two rulers.

**Figure 3**

Photo of EUT

Front View [ ]

Rear View [ ]

Top View [ ]

Bottom View [  ]

Left View [ ]

Right View [ ]

Full View [ ]



**Figure 4**

Photo of EUT

Front View [  ]

Rear View [ ]

Top View [ ]

Bottom View [ ]

Left View [ ]

Right View [ ]

Internal View [ ]





**Figure 5**

Photo of EUT

Front View [ ]

Rear View [ ]

Top View [ ]

Bottom View [ ]

Left View [✓]

Right View [ ]

Internal View [ ]



**Figure 6**

Photo of EUT

Front View [ ]

Rear View [✓]

Top View [ ]

Bottom View [ ]

Left View [ ]

Right View [ ]

Internal View [ ]



**Figure 7**

Photo of EUT

Front View [ ]

Rear View [ ]

Top View [ ]

Bottom View [ ]

Left View [ ]

Right View [ ✓ ]

Internal View [ ]



**Figure 8**

Photo of EUT

Front View [ ]

Rear View [ ]

Top View [ ]

Bottom View [ ]

Left View [ ]

Right View [ ]

Internal View [ ✓ ]

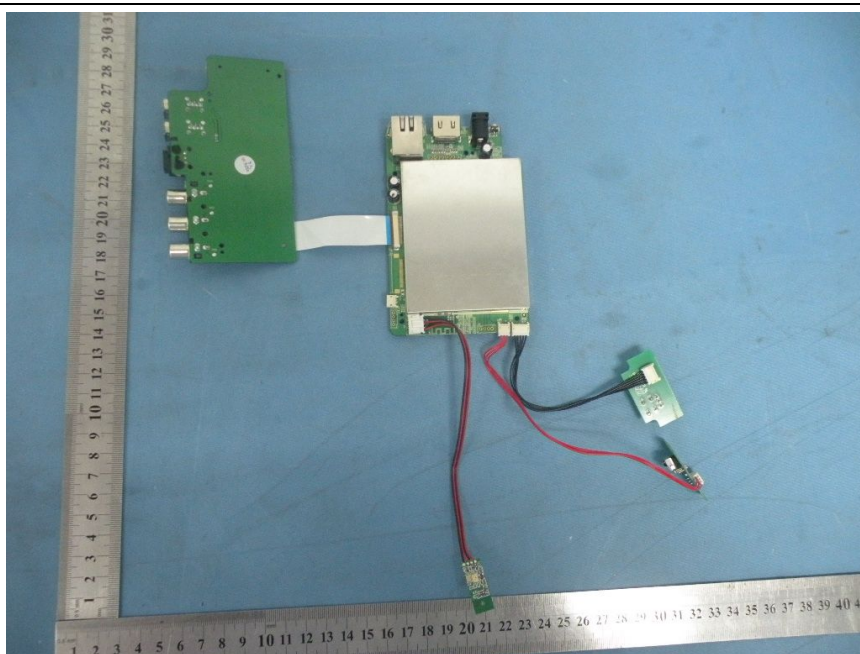



**Figure 9**

Photo of EUT

Front View [ ]

Rear View [ ]

Top View [ ]

Bottom View [ ]

Left View [ ]

Right View [ ]

Internal View [✓]

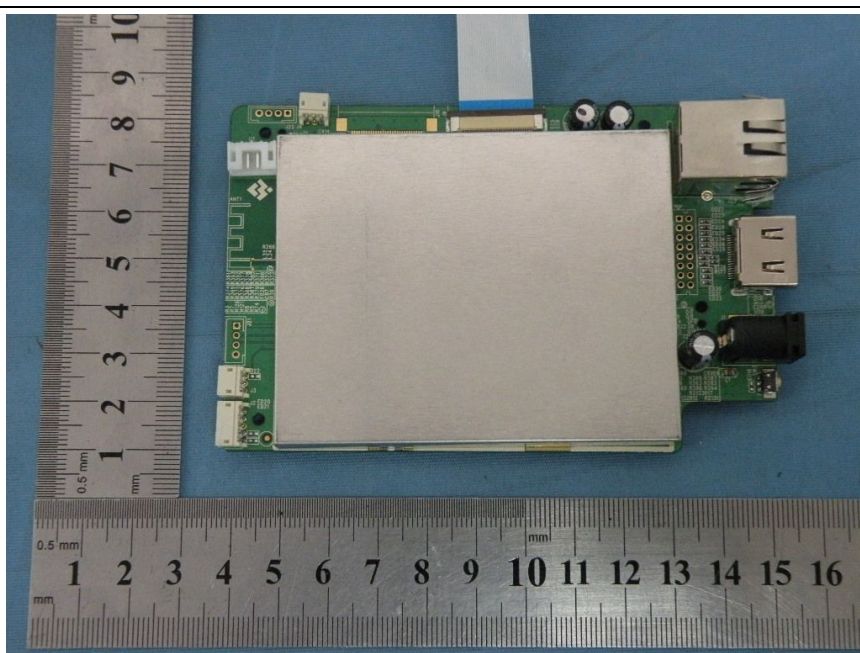

**Figure 10**

Photo of EUT

Front View [ ]

Rear View [ ]

Top View [ ]

Bottom View [ ]

Left View [ ]

Right View [ ]

Internal View [✓]

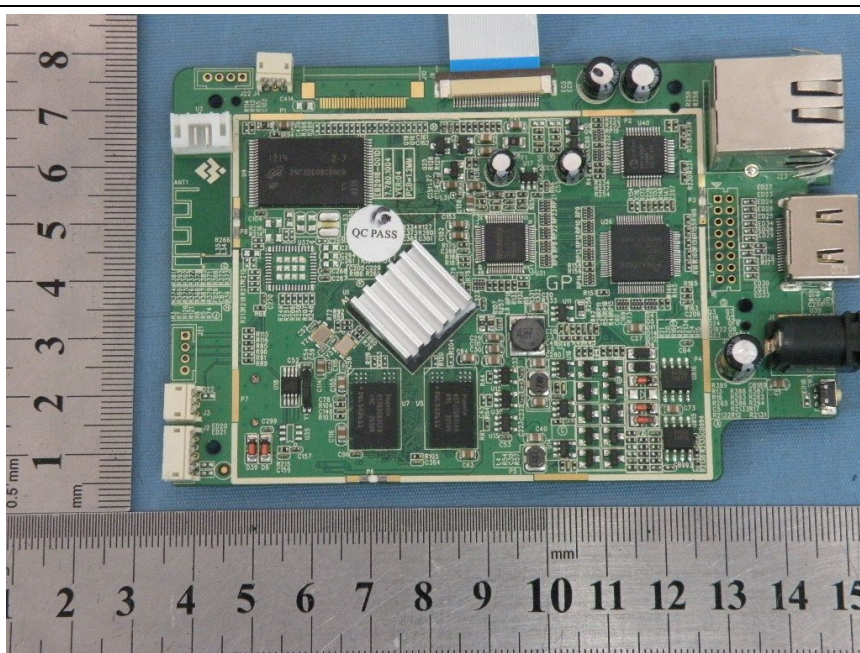

**Figure 11**

Photo of EUT

Front View [ ]

Rear View [ ]

Top View [ ]

Bottom View [ ]

Left View [ ]

Right View [ ]

Internal View [✓]

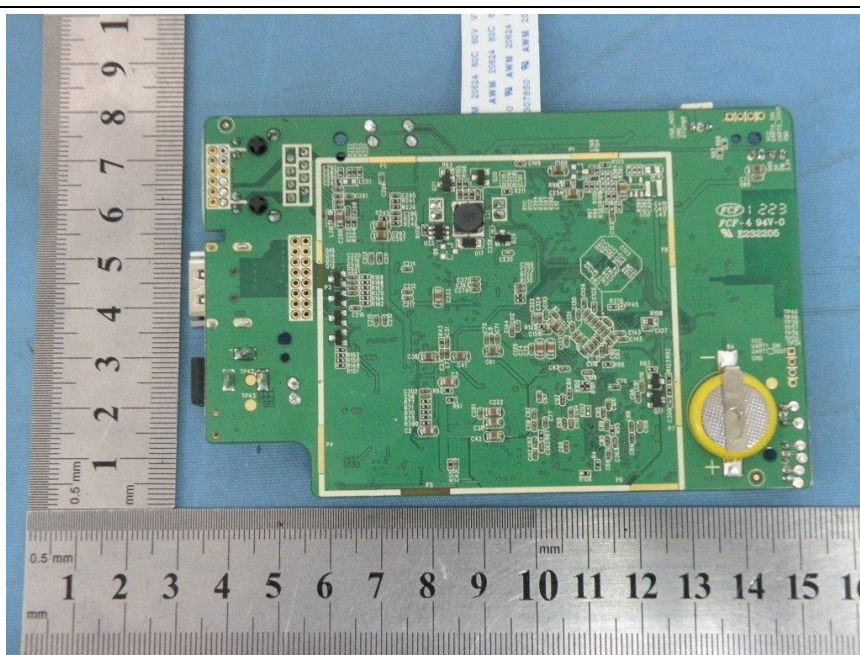

**Figure 12**

Photo of EUT

Front View [ ]

Rear View [ ]

Top View [ ]

Bottom View [ ]

Left View [ ]

Right View [ ]

Internal View [✓]

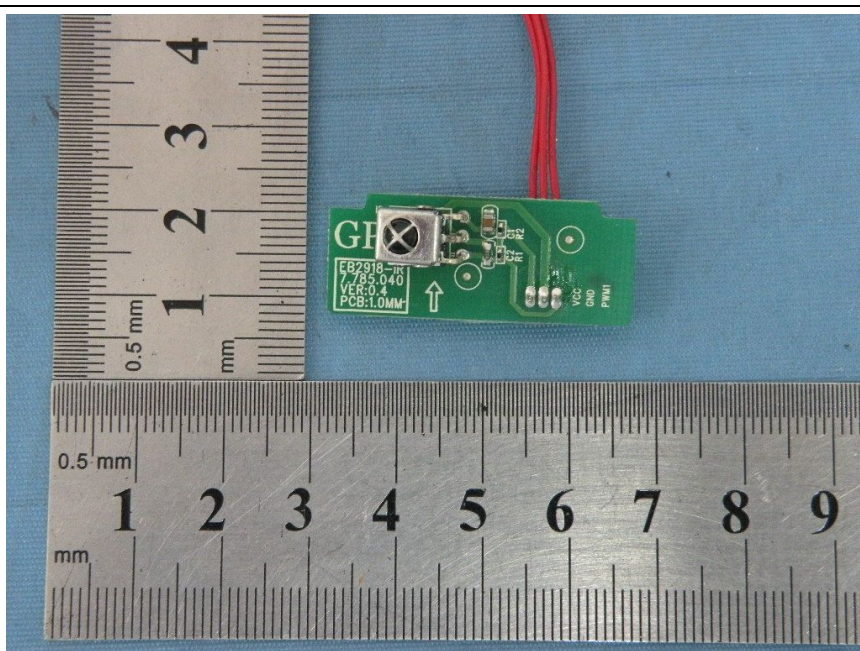



**Figure 13**

Photo of EUT

Front View [ ]

Rear View [ ]

Top View [ ]

Bottom View [ ]

Left View [ ]

Right View [ ]

Internal View [✓]

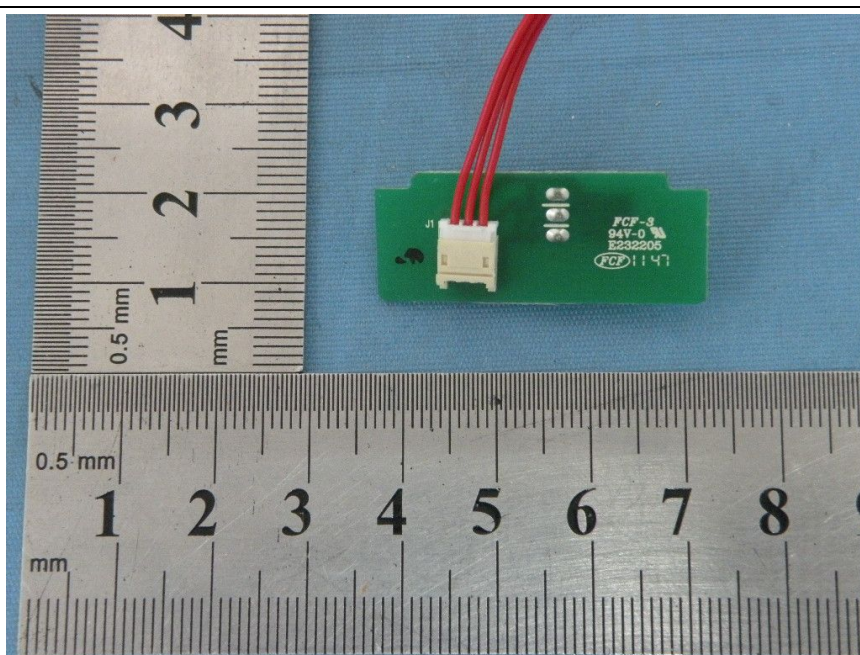

**Figure 14**

Photo of EUT

Front View [ ]

Rear View [ ]

Top View [ ]

Bottom View [ ]

Left View [ ]

Right View [ ]

Internal View [✓]

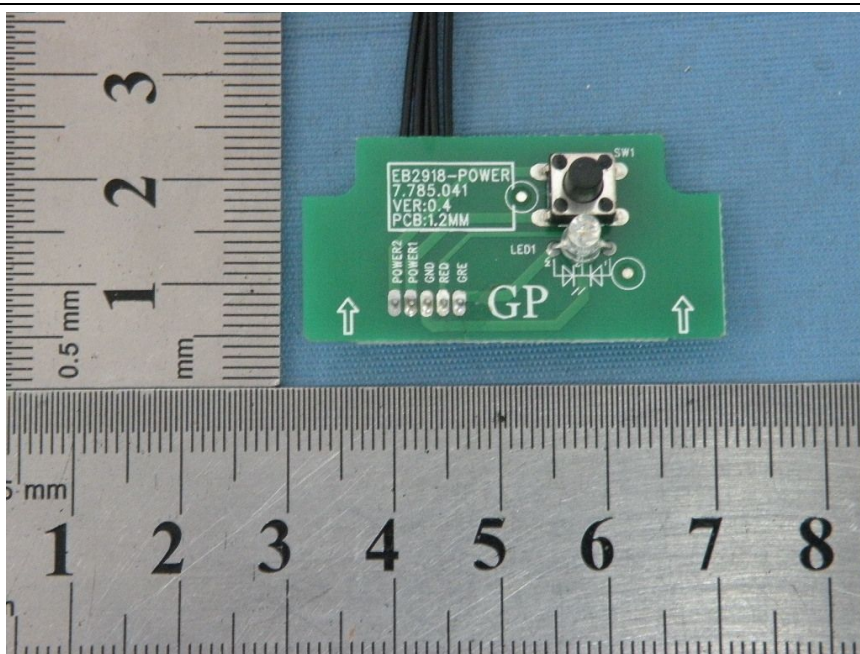



**Figure 15**

Photo of EUT

Front View [ ]

Rear View [ ]

Top View [ ]

Bottom View [ ]

Left View [ ]

Right View [ ]

Internal View [✓]

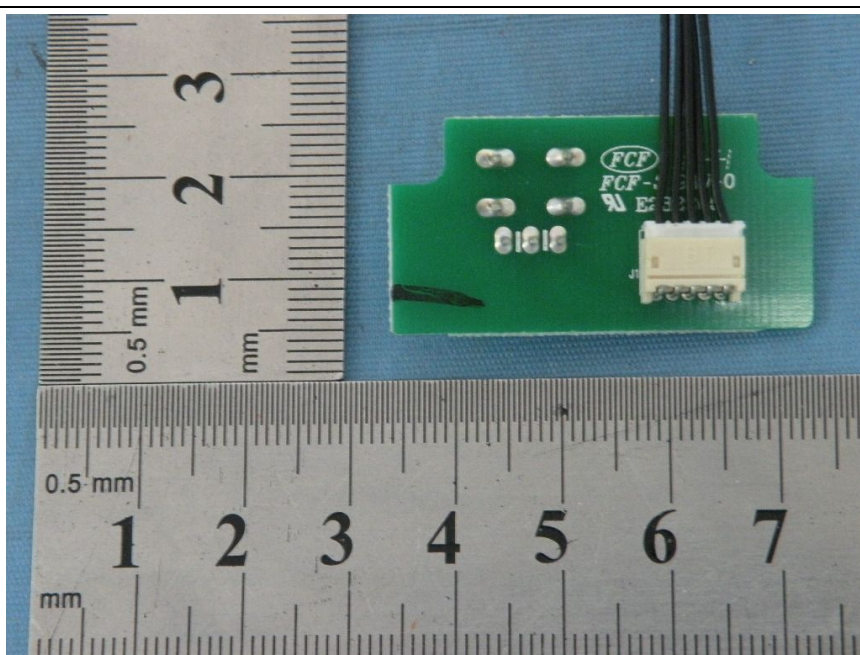

**Figure 16**

Photo of EUT

Front View [ ]

Rear View [ ]

Top View [ ]

Bottom View [ ]

Left View [ ]

Right View [ ]

Internal View [✓]

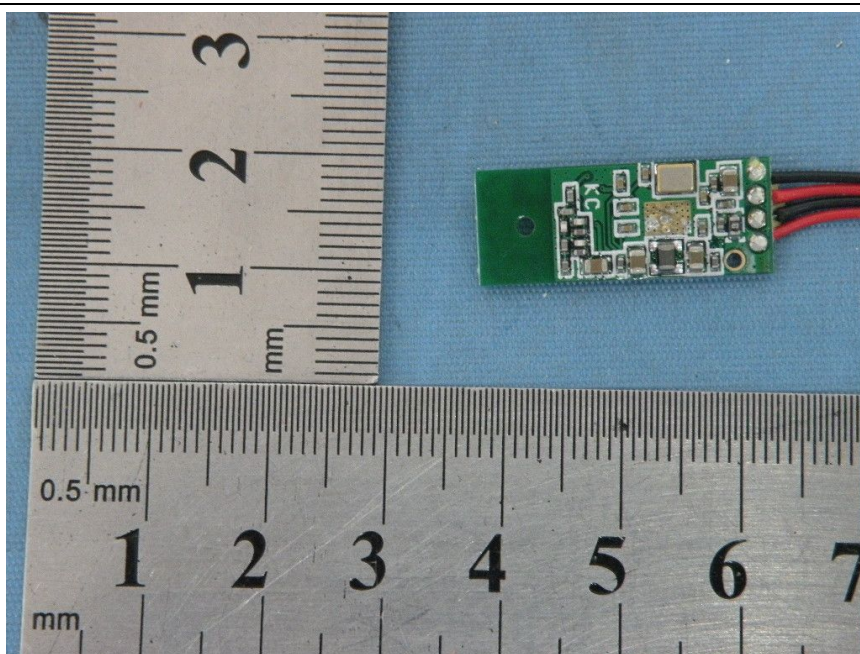

**Figure 17**

Photo of EUT

Front View [ ]

Rear View [ ]

Top View [ ]

Bottom View [ ]

Left View [ ]

Right View [ ]

Internal View [✓]

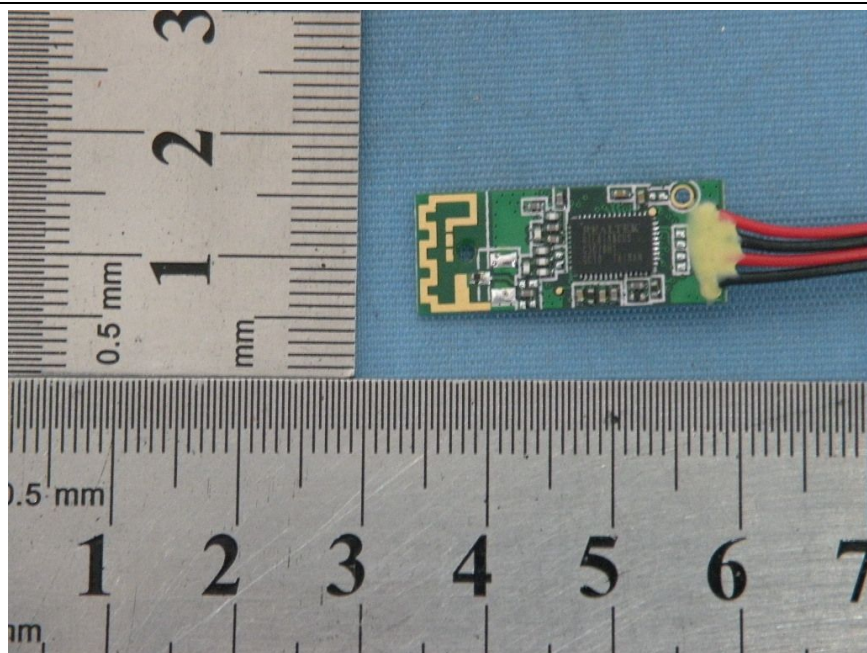

**Figure 18**

Photo of EUT

Front View [ ]

Rear View [ ]

Top View [ ]

Bottom View [ ]

Left View [ ]

Right View [ ]

Internal View [✓]

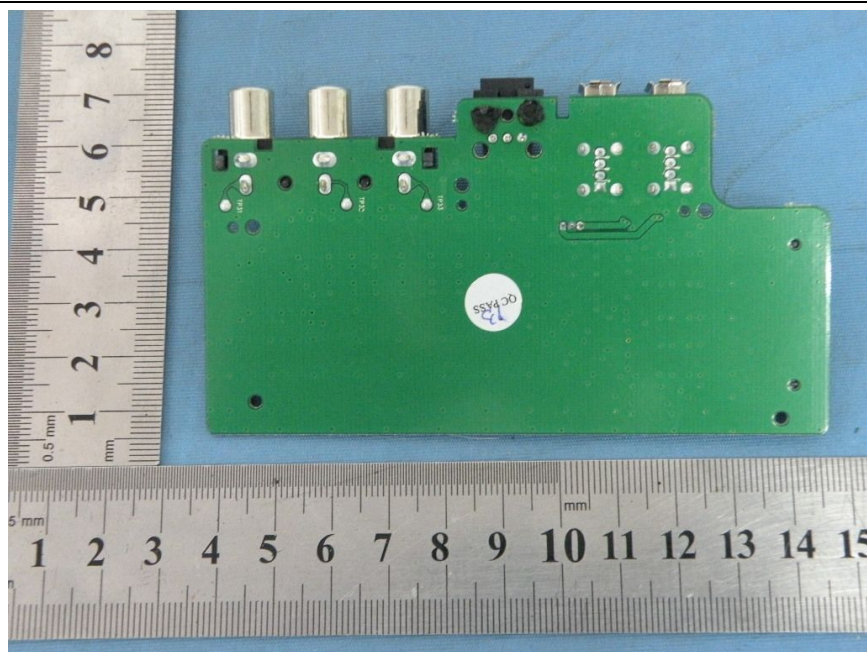

**Figure 19**

Photo of EUT

Front View [ ]

Rear View [ ]

Top View [ ]

Bottom View [ ]

Left View [ ]

Right View [ ]

Internal View [ ✓ ]

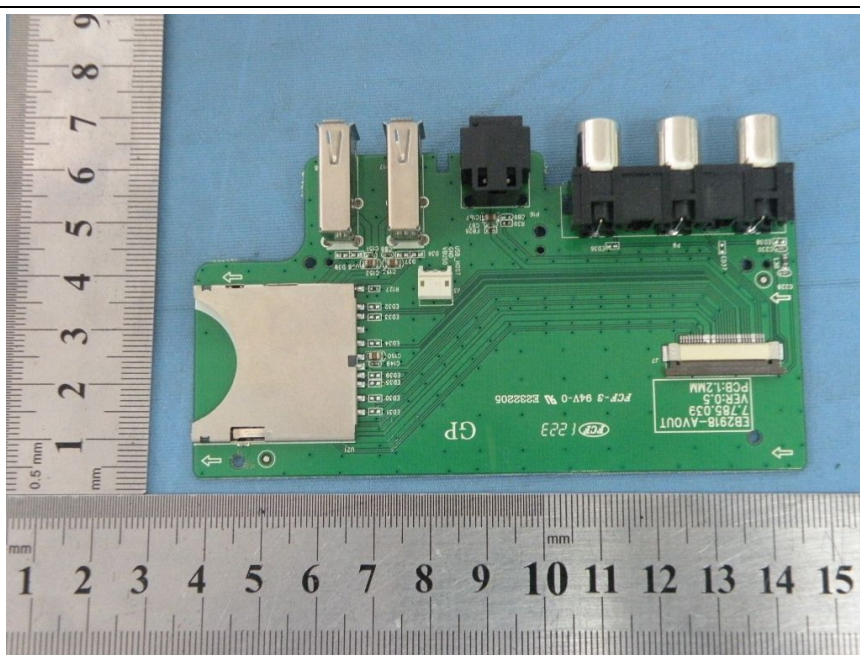

-----END OF THE REPORT-----