

TEST REPORT

of

FCC Part 22 Subpart H and Part 24 Subpart E
FCC ID : OELGM505YAA

Equipment Under Test : AUTO-CHEKT
Model Name : GM505YAA
Serial No. : N/A
Applicant : i-SENS Inc
Manufacturer : i-SENS Inc
Date of Test(s) : 2012.06.29 ~ 2012.07.03
Date of Issue : 2012.08.06

In the configuration tested, the EUT complied with the standards specified above.

Tested By:

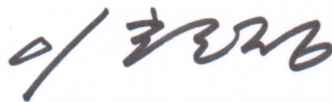

Date

2012. 08.06

Logan Lee

Approved By



Date

2012. 08.06

Feel Jeong

The results shown in this test report refer only to the sample(s) tested unless otherwise stated. This test report cannot be reproduced, except in full, without prior written permission of the Company.

INDEX

<u>TABLE OF CONTENTS</u>	Page
1. General Information -----	3
2. RF radiated output power & spurious radiated emission -----	7
3. Conducted Output Power -----	13
4. Occupied Bandwidth 99 % -----	15
5. Spurious Emissions At Antenna Terminal-----	21
6. Band Edge -----	25
7. Frequency Stability -----	28

The results shown in this test report refer only to the sample(s) tested unless otherwise stated. This test report cannot be reproduced, except in full, without prior written permission of the Company.

1. General information

1.1. Testing laboratory

SGS Korea Co., Ltd.(Gunpo Laboratory)

- 705, Dongchun-Dong Sooji-Gu, Yongin-Shi, Kyungki-Do, South Korea.
- Wireless Div. 3FL, 18-34, Sanbon-dong, Gunpo-si, Gyeonggi-do, Korea 435-040

www.ee.sgs.com/korea

Telephone : +82 31 428 5700

FAX : +82 31 427 2371

1.2. Details of applicant

Applicant : i-SENS Inc

Address : 465-14 WOLGYE-DONG, NOWON-GU, SEOUL

Contact Person : Shin, Hyunyoung

Phone No. : +82 2 910 0834

1.3. Description of EUT

Kind of Product	AUTO-CHEK T
Model Name	GM505YAA
Serial Number	N/A
Power Supply	DC 3.7 V
Rated Power	GSM850: 33 dB m GSM1900: 30 dB m
Frequency Range	GSM850: 824.2 MHz ~ 848.8 MHz GSM1900: 1 850.2 MHz ~ 1 909.8 MHz
Number of Channels	GSM850 : 125 GSM1900 : 300
Class of GPRS	Class 10, Class C
Emission Designator	246KGXD (GSM850) 243KGXD (GSM1900)

The results shown in this test report refer only to the sample(s) tested unless otherwise stated. This test report cannot be reproduced, except in full, without prior written permission of the Company.

1.4. Description of test mode

Band	Frequency (MHz)	GPRS Data	
		GPRS	GPRS
		1 TX Slot	2 TX Slot
		(dB m)	(dB m)
GSM850	824.2	32.31	32.21
	836.6	31.66	31.59
	848.8	31.59	31.57
GSM1900	1 850.2	29.80	29.76
	1 880.0	29.77	29.72
	1 909.8	29.59	29.58

GSM (850 / 1900)

We found out the test mode with the highest power level after we analyze all the data rates. So we chose **1 TX Slot of GPRS** (worst case) as a representative.

1.5. Sample calculation for offset

Where relevant, the following sample calculation is provided:

- GSM850

Frequency (MHz)	Reference Cable (dB)	Directional Coupler (dB)	Cable Loss (dB)	Result (dB)
836.6	0.87	13.00	2.31	15.31

-GSM1900

Frequency (MHz)	Reference Cable (dB)	Directional Coupler (dB)	Cable Loss (dB)	Result (dB)
1 880.0	1.34	13.00	3.92	16.92

-Worst case is band edge of spurious emission and band edge for GSM850

Frequency (MHz)	Reference Cable (dB)	Directional Coupler (dB)	Cable Loss (dB)	Result (dB)
823.980	0.41	13.00	2.25	15.25

Remark: band edge offset is less than offset of fundamental

-Worst case of band edge of spurious emission and band edge for GSM1900

Frequency (MHz)	Reference Cable (dB)	Directional Coupler (dB)	Cable Loss (dB)	Result (dB)
1 849.987	0.67	13.00	3.76	16.76

Remark: band edge offset is less than offset of fundamental

Calculation of offset value:

Result = Directional Coupler + Cable loss

The results shown in this test report refer only to the sample(s) tested unless otherwise stated. This test report cannot be reproduced, except in full, without prior written permission of the Company.

1.6. Test equipment list

Equipment	Manufacturer	Model	S/N	Cal Date	Cal Interval	Cal Due.
Signal Generator	Agilent	E4438C	MY42082477	Mar. 29, 2012	Annual	Mar. 29, 2013
Signal Generator	R&S	SMR40	100272	Jul, 15, 2011	Annual	Jul, 15, 2012
Spectrum Analyzer	R&S	FSV30	100768	Mar. 29, 2012	Annual	Mar. 29, 2013
Mobile Test Unit	Agilent	E5515C	GB43345198	Mar. 29, 2012	Annual	Mar. 29, 2013
Directional Coupler	KRYTAR	152613	122661	Apr. 04, 2012	Annual	Apr. 04, 2013
Attenuator	Mini-Circuits	BW-N20W5+	0950-1	Mar. 30, 2012	Annual	Mar. 30, 2013
High Pass Filter	Wainwright	WHK3.0/18G-10SS	344	Jul. 07, 2011	Annual	Jul. 07, 2012
Band Reject Filter	Wainwright	WRCG824/849-814/85960 /10SS	7	Mar. 31, 2012	Annual	Mar. 31, 2013
DC Power Supply	Agilent	U8002A	MY49030063	Jan. 03, 2012	Annual	Jan. 03, 2013
Preamplifier	H.P.	8447F	2944A03909	Jul. 04, 2011	Annual	Jul. 04, 2012
Preamplifier	R & S	SCU 18	10117	Jan. 02, 2012	Annual	Jan. 02, 2013
Preamplifier	MITEQ Inc.	JS44-18004000-35-8P	1546891	Jul. 04, 2011	Annual	Jul. 04, 2012
Test Receiver	R & S	ESU26	100109	Feb. 21, 2012	Annual	Feb. 21, 2013
Bilog Antenna	SCHWARZBECK	VULB9163	396	May 12, 2011	Biennial	May 12, 2013
Horn Antenna	R & S	HF 906	100326	Nov. 23, 2010	Biennial	Nov. 23, 2012
Horn Antenna	SCHWARZBECK	BBHA9170	BBHA9170431	May 15, 2012	Biennial	May 15, 2014
Dipole Antenna	SCHWARZBECK	VHA/UHA	9103/9105	May 24, 2011	Biennial	May 24, 2013
Antenna Master	INN-CO	MM4000	N/A	N.C.R.	N/A	N.C.R.
Turn Table	INN-CO	DS 1200 S	N/A	N.C.R.	N/A	N.C.R.
Anechoic Chamber	SY Corporation	L x W x H (9.6 m x 6.4 m x 6.6 m)	N/A	N.C.R.	N/A	N.C.R.

The results shown in this test report refer only to the sample(s) tested unless otherwise stated. This test report cannot be reproduced, except in full, without prior written permission of the Company.

1.7. Summary of test results

The EUT has been tested according to the following specifications:

APPLIED STANDARD : FCC Part 22, 24		
Section in FCC part	Test Item	Result
§2.1046 §22.913(a) §24.232(b)	RF Radiated Output Power	Complied
§2.1053 §22.917(e) §24.238(a)	Spurious Radiated Emission	Complied
§2.1046(a)	Conducted Output Power	Complied
§2.1049(h) (i)	Occupied Bandwidth	Complied
§2.1051 §22.917(e) §24.238(a)	Spurious Emission at Antenna Terminal	Complied
§2.1055 §22.355 §24.235	Frequency Stability	Complied
§22.917(e) §24.238(a)	Band Edge	Complied
§1.1307 §2.1091	RF Exposure Evaluation	Complied

1.8. Test report revision

Revision	Report number	Description
0	F690501/RF-RTL005635	Initial
1	F690501/RF-RTL005635-1	Removed RF exposure test result
2	F690501/RF-RTL005635-2	Modify FCC ID

The results shown in this test report refer only to the sample(s) tested unless otherwise stated. This test report cannot be reproduced, except in full, without prior written permission of the Company.

2. RF radiated output power & spurious radiated emission

2.1. Test setup

The diagram below shows the test setup that is utilized to make the measurements for emission from 30 MHz to 1 GHz Emissions.

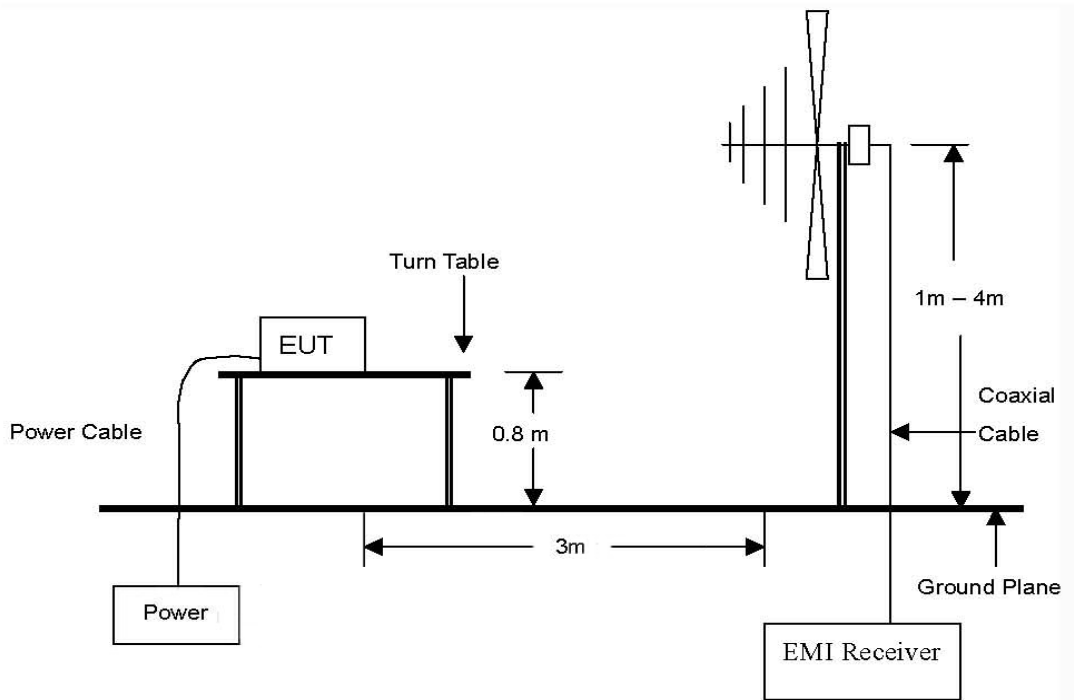

The diagram below shows the test setup that is utilized to make the measurements for emission from 1 GHz to 20 GHz Emissions.

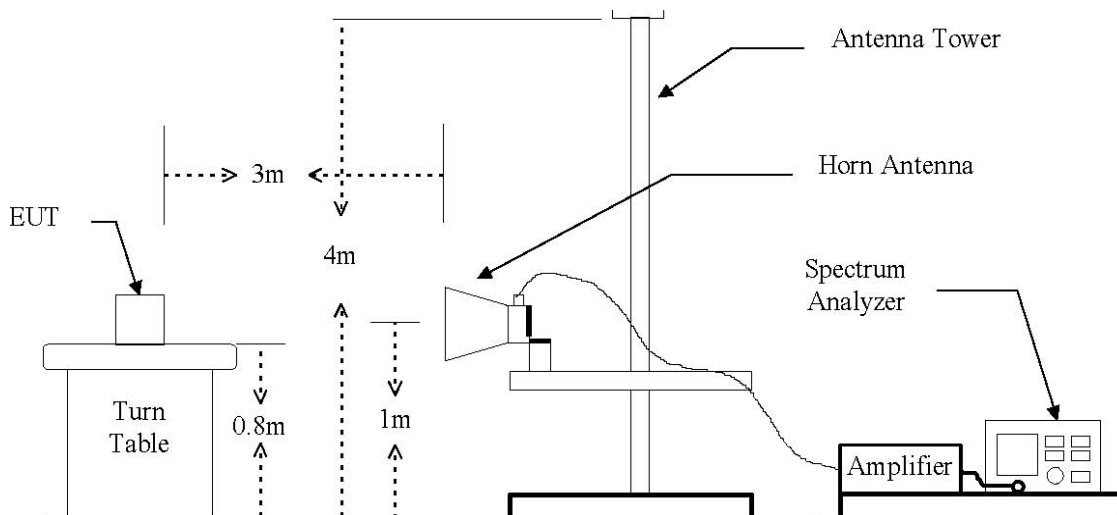

The results shown in this test report refer only to the sample(s) tested unless otherwise stated. This test report cannot be reproduced, except in full, without prior written permission of the Company.

The diagram below shows the test setup for substituted method

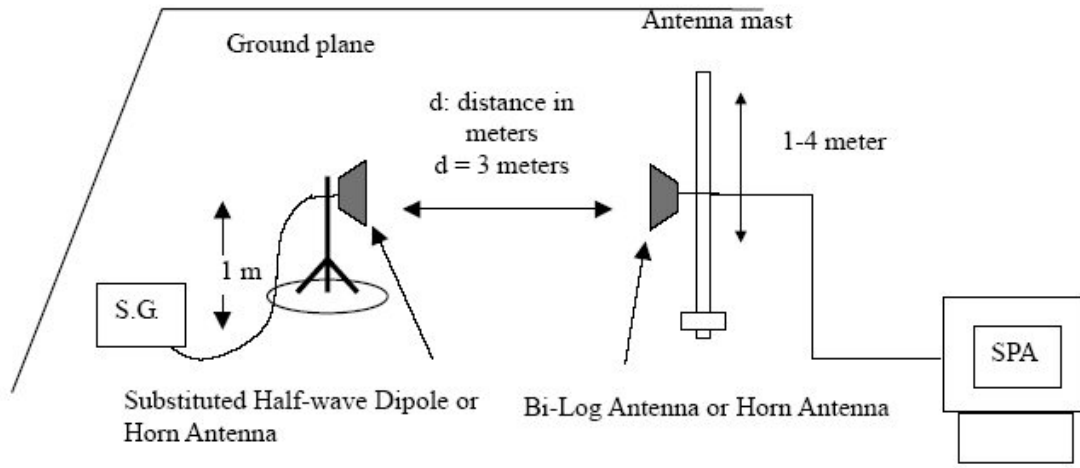

The results shown in this test report refer only to the sample(s) tested unless otherwise stated. This test report cannot be reproduced, except in full, without prior written permission of the Company.

2.2. Limit

FCC §22.913(a), the ERP of mobile transmitters must not exceed 7 watts. FCC §24.232(b) Mobile/portable stations are limited to 2 watts e.i.r.p. peak power and the equipment must employ means to limit the power to the minimum necessary for successful communications.

2.3. Test procedure : Based on ANSI/TIA 603C: 2004

1. On a test site, the EUT shall be placed at 80cm height on a turn table, and in the position close to normal use as declared by the applicant.
2. The test antenna shall be oriented initially for vertical polarization located 3 m from EUT to correspond to the fundamental frequency of the transmitter.
3. The output of the test antenna shall be connected to the measuring receiver and the peak detector is used for the measurement.
4. During the measurement of the EUT, the resolution bandwidth was to 1 MHz and the average bandwidth was set to 1 MHz.
5. The transmitter shall be switched on, the measuring receiver shall be tuned to the frequency of the transmitter under test.
6. The test antenna shall be raised and lowered through the specified range of height until the maximum signal level is detected by the measuring receiver.
7. The transmitter shall be rotated through 360° in the horizontal plane, until the maximum signal level is detected by the measuring receiver.
8. The test antenna shall be raised and lowered again through the specified range of height until the maximum signal level is detected by the measuring receiver.
9. The maximum signal level detected by the measuring receiver shall be noted.
10. The EUT was replaced by half-wave dipole (824 ~ 849 MHz) or horn antenna (1 850 ~ 1 910 MHz) connected to a signal generator.
11. In necessary, the input attenuator setting on the measuring receiver shall be adjusted in order to increase the sensitivity of the measuring receiver.
12. The test antenna shall be raised and lowered through the specified range of height to ensure that the maximum signal is received.
13. The input signal to the substitution antenna shall be adjusted to the level that produces a level detected by the measuring receiver, which is equal to the level noted while the transmitter radiated power was measured, corrected for the change of input attenuator setting of the measuring receiver.
14. The input level to the substitution antenna shall be recorded as power level in dB m, corrected for any change of input attenuator setting of the measuring receiver.
15. The measurement shall be repeated with the test antenna and the substitution antenna orientated for horizontal polarization.

The results shown in this test report refer only to the sample(s) tested unless otherwise stated. This test report cannot be reproduced, except in full, without prior written permission of the Company.

2.4. Test result for RF radiated output power

Ambient temperature : (24 ± 2) °C
 Relative humidity : 47 % R.H.

GSM850

Frequency (MHz)	Ant. Pol. (H/V)	S.G level + Amp. (dB m)	Cable loss (dB)	Ant. gain (dB d)	E.R.P.	
					(dB m)	(mW)
824.2	V	35.88	3.42	-3.44	29.02	797.99
824.2	H	38.58	3.42	-3.44	31.72	1 485.94
836.4	V	36.69	3.38	-3.45	29.86	968.28
836.4	H	36.99	3.38	-3.45	30.16	1 037.53
848.8	V	36.91	3.33	-3.41	30.17	1 039.92
848.8	H	38.34	3.33	-3.41	31.60	1 445.44

GSM1900

Frequency (MHz)	Ant. Pol. (H/V)	S.G level + Amp. (dB m)	Cable loss (dB)	Ant. gain (dB i)	E.I.R.P.	
					(dB m)	(mW)
1 850.2	V	20.13	4.87	7.55	22.81	190.99
1 850.2	H	23.97	4.87	7.55	26.65	462.38
1 880.0	V	17.89	4.91	7.63	20.61	115.08
1 880.0	H	25.67	4.91	7.63	28.39	690.24
1 909.8	V	18.67	4.94	7.70	21.43	139.00
1 909.8	H	25.23	4.94	7.70	27.99	629.51

Remark:

1. E.R.P. & E.I.R.P = [S.G level + Amp.](dB m) - Cable loss(dB) + Ant. gain (dB d/dB i)
2. The E.I.R.P was measured in three orthogonal EUT position (x-axis, y-axis and z-axis). Worst cases are y -axis.

The results shown in this test report refer only to the sample(s) tested unless otherwise stated. This test report cannot be reproduced, except in full, without prior written permission of the Company.

2.5. Spurious radiated emission

- Measured output Power: 31.72 dB m = 1.485 9 W
- Modulation Signal: GSM850
- Distance: 3 meters
- Limit: $-(43 + 10\log_{10}(W)) = -44.72$ dB c

Frequency (MHz)	Ant. Pol. (H/V)	S.G level + Amp. (dB m)	Cable loss (dB)	Ant. gain (dB d)	E.R.P (dB m)	dB c	Margin (dB)
Low Channel (824.2 MHz)							
1 648.45	V	-45.55	4.54	6.44	-43.65	-75.37	30.65
1 648.48	H	-49.34	4.54	6.44	-47.44	-79.16	34.44
2 472.59	V	-49.52	5.67	7.97	-47.22	-78.94	34.22
2 472.75	H	-49.49	5.67	7.97	-47.19	-78.91	34.19
Middle Channel (836.4 MHz)							
1 673.36	V	-44.33	4.58	6.51	-42.40	-74.12	29.40
1 673.04	H	-50.11	4.58	6.50	-48.19	-79.91	35.19
2 509.85	V	-50.70	5.72	8.02	-48.40	-80.12	35.40
2 509.95	H	-44.20	5.72	8.02	-41.90	-73.62	28.90
High Channel (848.8 MHz)							
1 697.69	V	-40.20	4.62	6.57	-38.25	-69.97	25.25
1 697.54	H	-48.65	4.62	6.57	-46.70	-78.42	33.70
2 546.20	V	-52.53	5.75	8.07	-50.21	-81.93	37.21
2 546.24	H	-46.77	5.75	8.07	-44.45	-76.17	31.45

The results shown in this test report refer only to the sample(s) tested unless otherwise stated. This test report cannot be reproduced, except in full, without prior written permission of the Company.

- Measured output Power : 28.39 dB m = 0.690 2 W
- Modulation Signal : GSM1900
- Distance : 3 meters
- Limit : $-(43 + 10\log_{10}(W)) = -41.39$ dB c

Frequency (MHz)	Ant. Pol. (H/V)	S.G level + Amp. (dB m)	Cable loss (dB)	Ant. gain (dB i)	E.I.R.P (dB m)	dB c	Margin (dB)
Low Channel(1 850.2 MHz)							
3 700.40	V	-59.65	7.13	11.85	-54.93	-83.32	41.93
3 700.33	H	-46.92	7.13	11.85	-42.20	-70.59	29.20
5 550.67	V	-46.42	9.24	12.12	-43.54	-71.93	30.54
5 550.76	H	-47.25	9.24	12.12	-44.37	-72.76	31.37
Middle Channel(1 880.0 MHz)							
3 760.04	V	-59.75	7.23	11.85	-55.13	-83.52	42.13
3 760.00	H	-48.47	7.23	11.85	-43.85	-72.24	30.85
5 639.86	V	-48.25	9.36	12.08	-45.53	-73.92	32.53
5 639.93	H	-48.03	9.36	12.08	-45.31	-73.70	32.31
High Channel(1 909.8 MHz)							
3 819.63	V	-61.04	7.33	11.84	-56.53	-84.92	43.53
3 819.62	H	-48.00	7.33	11.84	-43.49	-71.88	30.49
5729.67	V	-44.73	9.46	12.04	-42.15	-70.54	29.15
5729.33	H	-46.37	9.46	12.04	-43.79	-72.18	30.79

Remark:

1. $E.I.R.P. \& \ E.I.R.P = S.G \ level \ (dB \ m) - Cable \ loss \ (dB) + Ant. \ gain \ (dB \ d/dB \ i)$
2. No more harmonic above 3rd harmonic for all channel.

The results shown in this test report refer only to the sample(s) tested unless otherwise stated. This test report cannot be reproduced, except in full, without prior written permission of the Company.

3. Conducted Output Power

3.1. Limit

Requirements: CFR 47, Section §2.1046

3.2. Test Procedure

1. The RF output of the transmitter was connected to the input of the Mobile Communication Test Unit through sufficient attenuation.
2. The mobile was set up for the max. output power with pseudo random data modulation.
3. The power was measured with Mobile Communication Test unit.

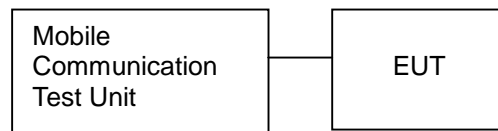

The results shown in this test report refer only to the sample(s) tested unless otherwise stated. This test report cannot be reproduced, except in full, without prior written permission of the Company.

3.3. Test Result

Ambient temperature : (24 ± 2) °C
 Relative humidity : 47 % R.H.

Band	Frequency (MHz)	GPRS Data	
		GPRS	GPRS
		1 TX Slot	2 TX Slot
		(dB m)	(dB m)
GSM850	824.2	32.31	32.21
	836.6	31.66	31.59
	848.8	31.59	31.57
GSM1900	1 850.2	29.80	29.76
	1 880.0	29.77	29.72
	1 909.8	29.59	29.58

The results shown in this test report refer only to the sample(s) tested unless otherwise stated. This test report cannot be reproduced, except in full, without prior written permission of the Company.

4. Occupied Bandwidth 99 %

4.1. Limit

Requirements: CFR 47, Section §2.1049.

4.2. Test Procedure

1. The RF output of the transmitter was connected to the input of the spectrum analyzer through sufficient attenuation.
2. The resolution bandwidth of the spectrum analyzer was set.
Occupied Bandwidth 99 % was tested under

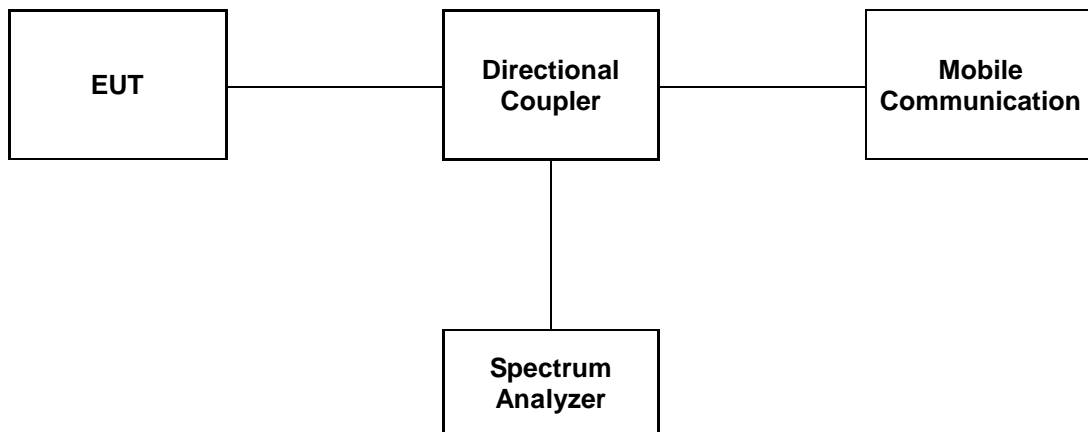

The results shown in this test report refer only to the sample(s) tested unless otherwise stated. This test report cannot be reproduced, except in full, without prior written permission of the Company.

4.3 Test Results

Ambient temperature : (24 ± 2) °C
 Relative humidity : 47 % R.H.

Band	Mode	Frequency (MHz)	Occupied Bandwidth (MHz)
GSM850	GPRS 1 TX	824.2	0.245
		836.4	0.246
		848.8	0.242
GSM1900	GPRS 1 TX	1 850.2	0.243
		1 880.0	0.243
		1 909.8	0.243

Please refer to the following plots.

The results shown in this test report refer only to the sample(s) tested unless otherwise stated. This test report cannot be reproduced, except in full, without prior written permission of the Company.

GSM850

99 %

Low Channel

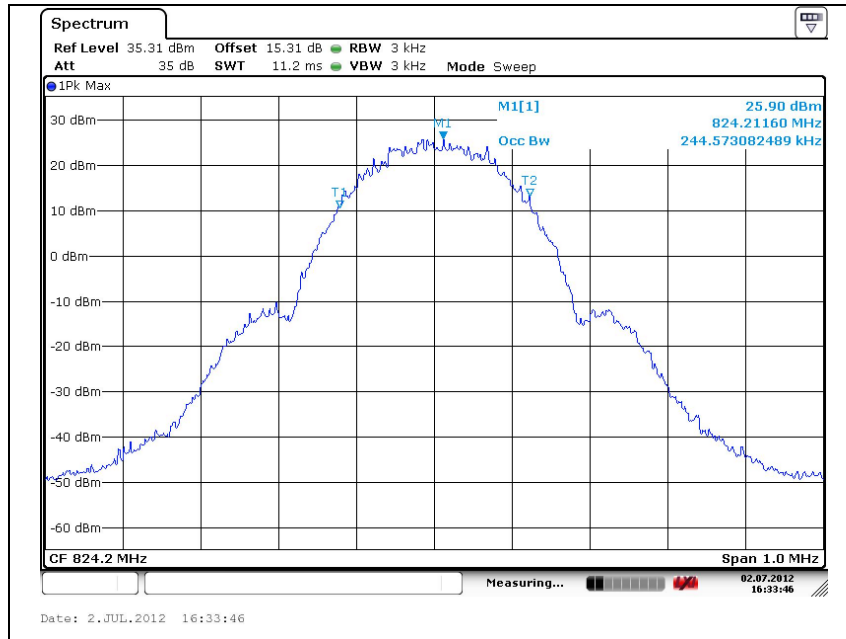

Middle Channel

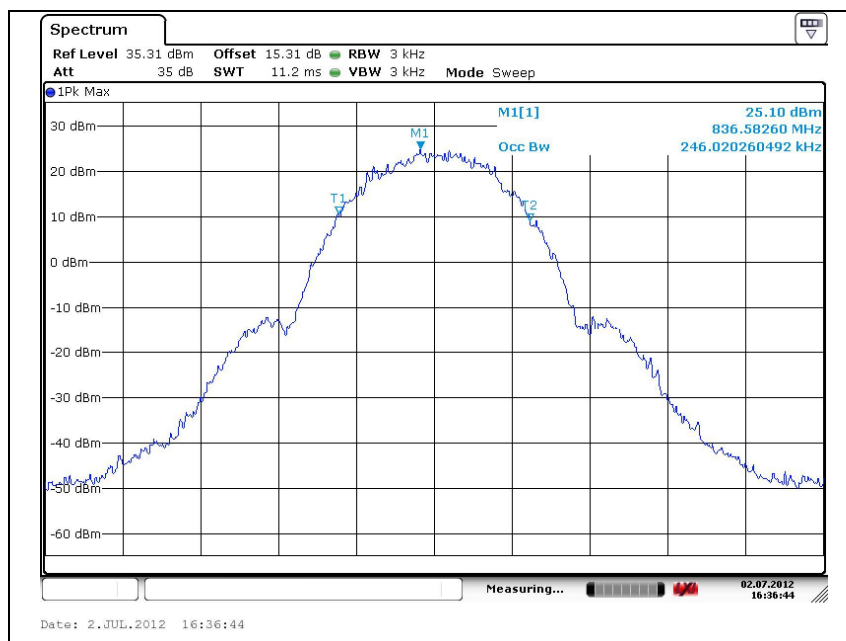

The results shown in this test report refer only to the sample(s) tested unless otherwise stated. This test report cannot be reproduced, except in full, without prior written permission of the Company.

High Channel

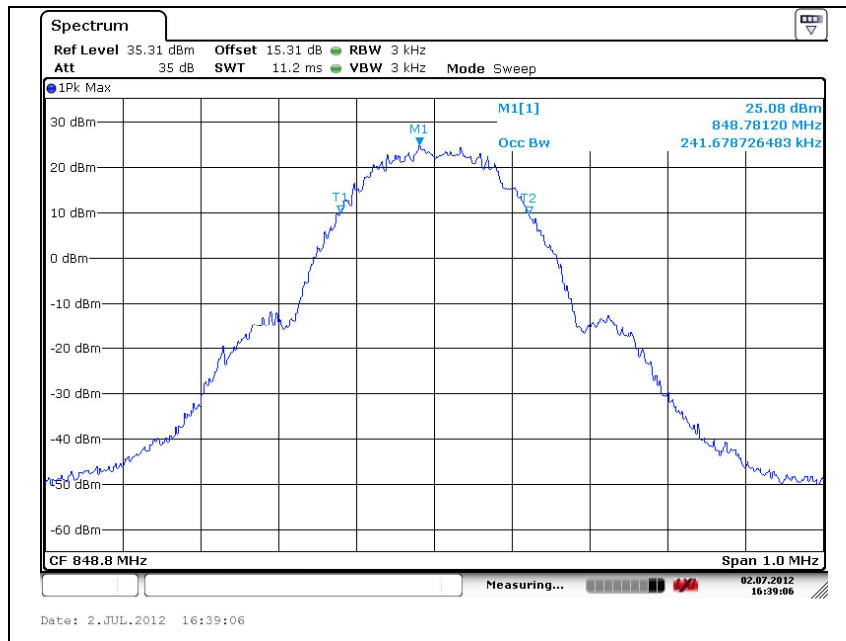

The results shown in this test report refer only to the sample(s) tested unless otherwise stated. This test report cannot be reproduced, except in full, without prior written permission of the Company.

GSM1900

99 %

Low Channel

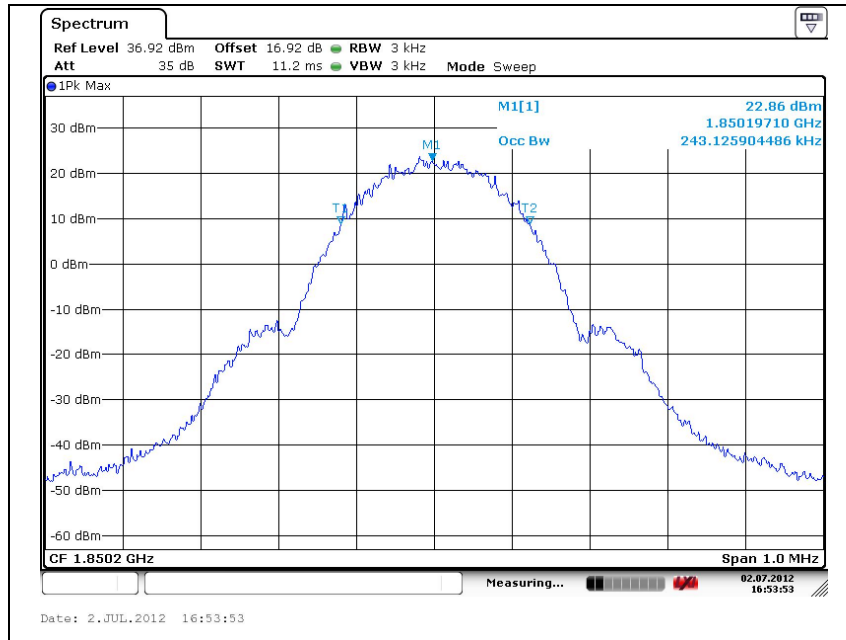

Middle Channel

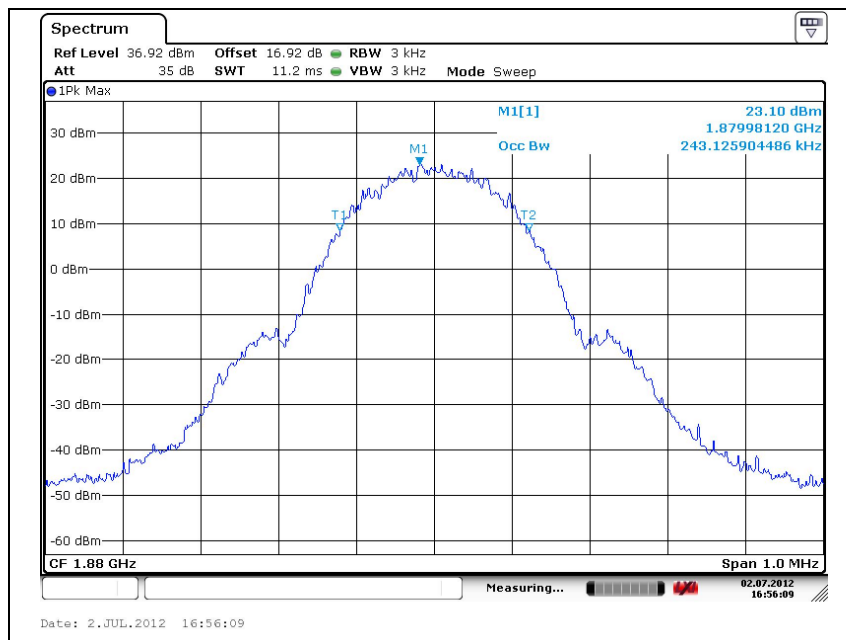

The results shown in this test report refer only to the sample(s) tested unless otherwise stated. This test report cannot be reproduced, except in full, without prior written permission of the Company.

High Channel

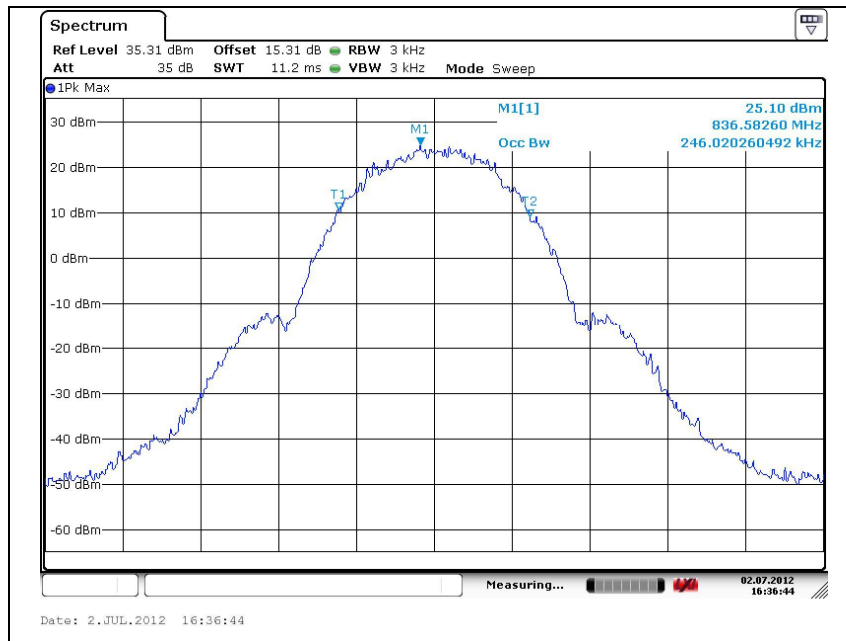

The results shown in this test report refer only to the sample(s) tested unless otherwise stated. This test report cannot be reproduced, except in full, without prior written permission of the Company.

5. Spurious Emissions at Antenna Terminal

5.1. Limit

§ 22.917(e) and §24.238 (a) Out of band emissions. The power of any emission outside of the authorized operating frequency must be attenuated below the transmitting (P) by a factor of at least $43 + 10\log(P)$ dB.

5.2. Test Procedure

1. The RF output of the transceiver was connected to a spectrum analyzer through appropriate attenuation.
2. The resolution bandwidth of the spectrum analyzer was set at 1 MHz. Sufficient scans were taken to show any out of band emissions up to 10th harmonic.

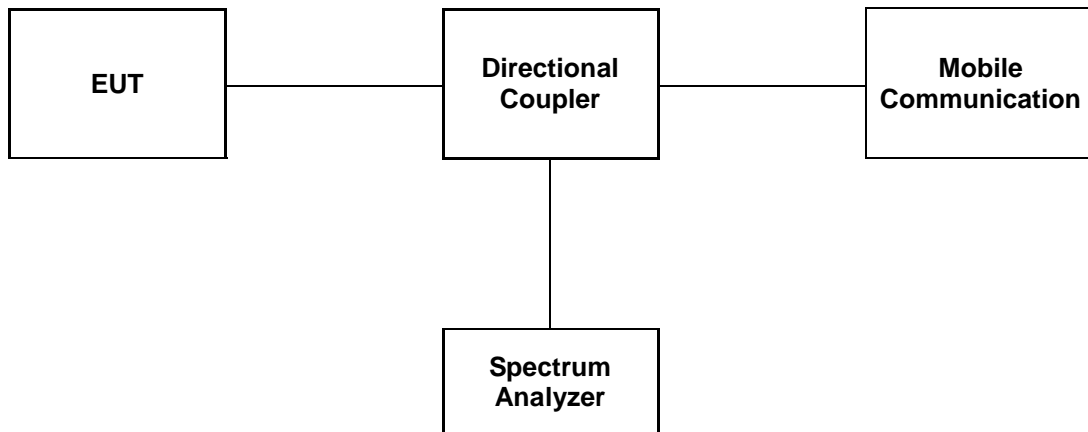

The results shown in this test report refer only to the sample(s) tested unless otherwise stated. This test report cannot be reproduced, except in full, without prior written permission of the Company.

5.3. Test Results

Ambient temperature : (24 ± 2) °C
 Relative humidity : 47 % R.H.

Please refer to the following plots.

GSM850

Low Channel

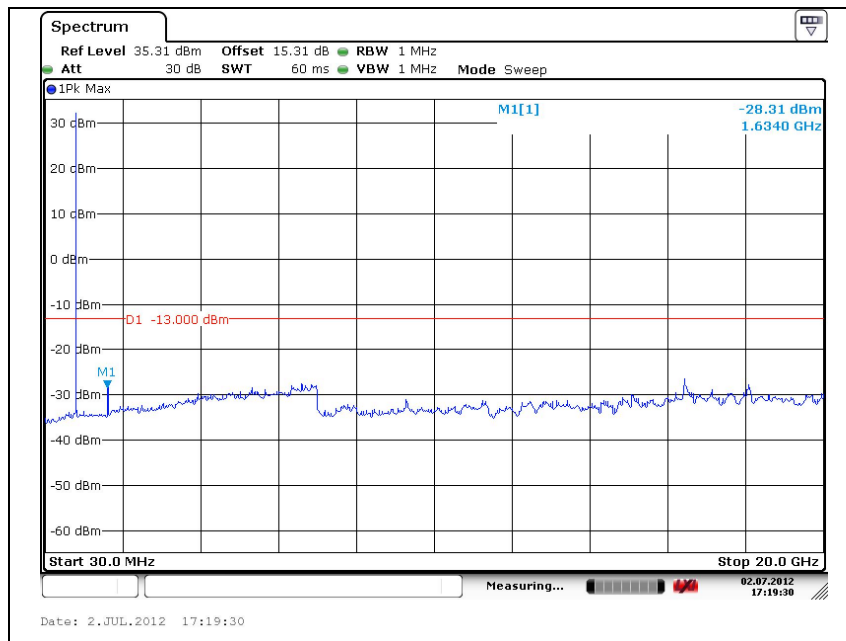

Middle Channel

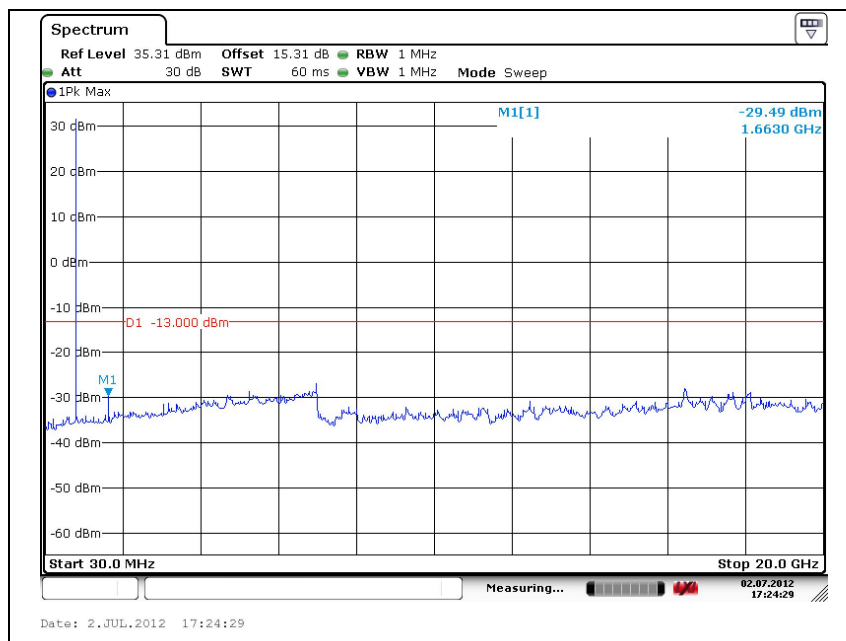

The results shown in this test report refer only to the sample(s) tested unless otherwise stated. This test report cannot be reproduced, except in full, without prior written permission of the Company.

High Channel

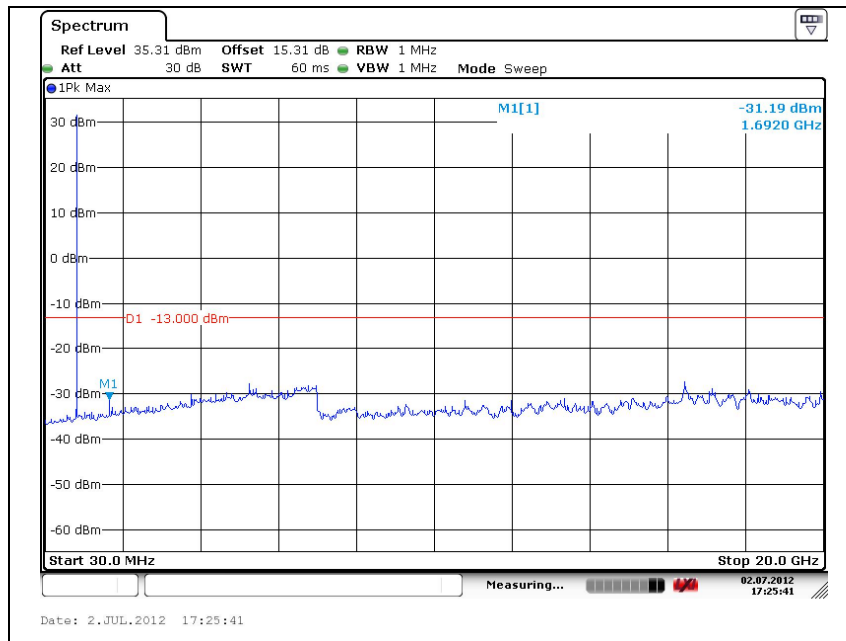

GSM1900 Low Channel

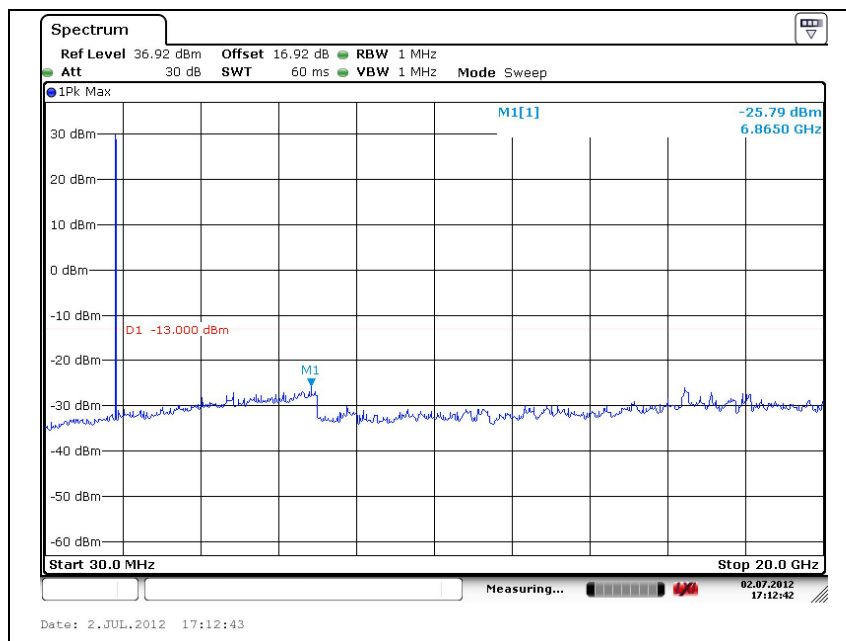

The results shown in this test report refer only to the sample(s) tested unless otherwise stated. This test report cannot be reproduced, except in full, without prior written permission of the Company.

Middle Channel

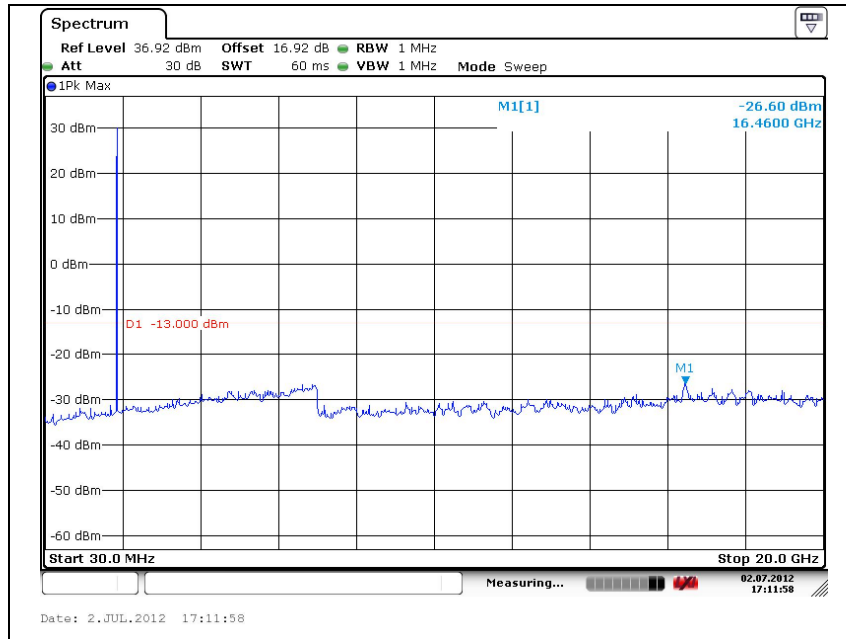

High Channel

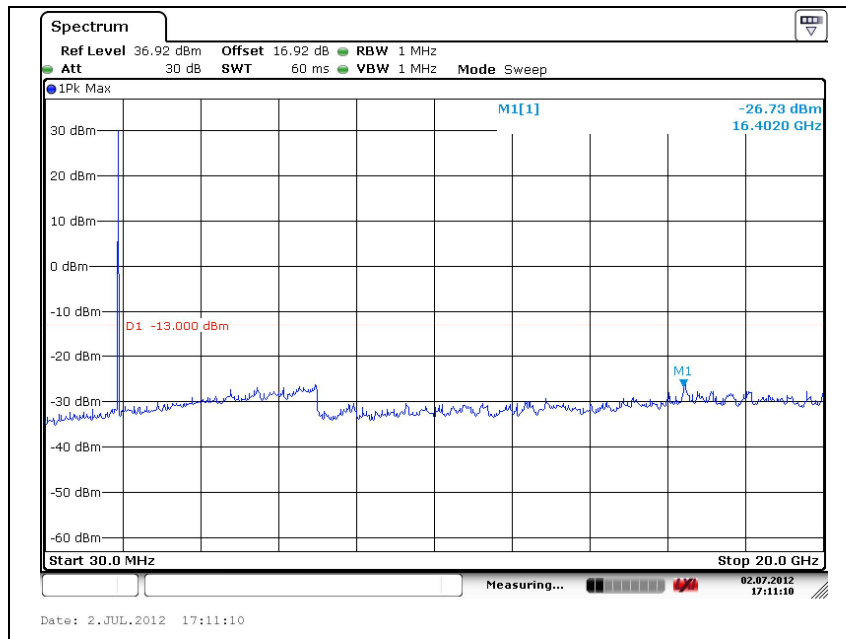

The results shown in this test report refer only to the sample(s) tested unless otherwise stated. This test report cannot be reproduced, except in full, without prior written permission of the Company.

6. Band Edge

6.1. Limit

§ 22.917(e) and §24.238 (a) Out of band emissions. The power of any emission outside of the authorized operating frequency must be attenuated below the transmitting (P) by a factor of at least $43+10\log(P)$ dB.

6.2. Test Procedure

1. The RF output of the transmitter was connected to the input of the spectrum analyzer through sufficient attenuation.
2. The center of the spectrum analyzer was set to block edge frequency.

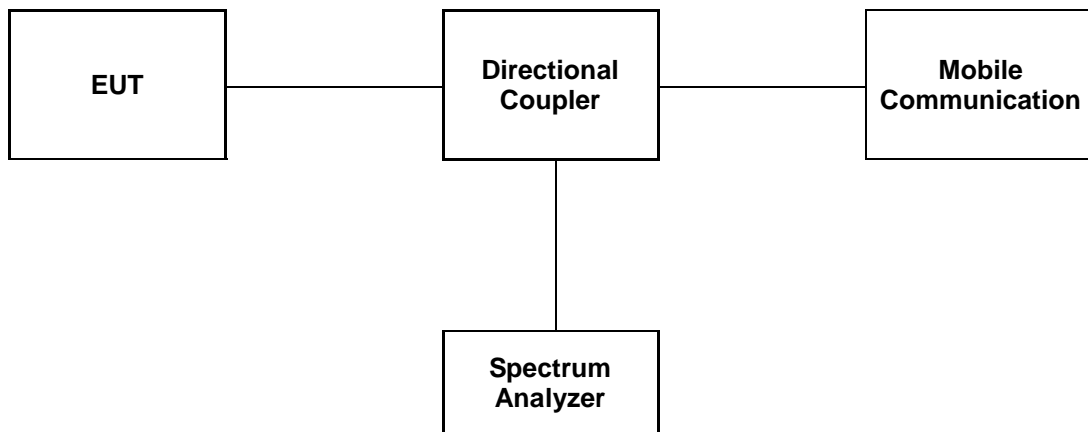

The results shown in this test report refer only to the sample(s) tested unless otherwise stated. This test report cannot be reproduced, except in full, without prior written permission of the Company.

6.3. Test Results

Ambient temperature : (24 ± 2) °C
 Relative humidity : 47 % R.H.

Please refer to the following plots.

GSM850 Low Channel

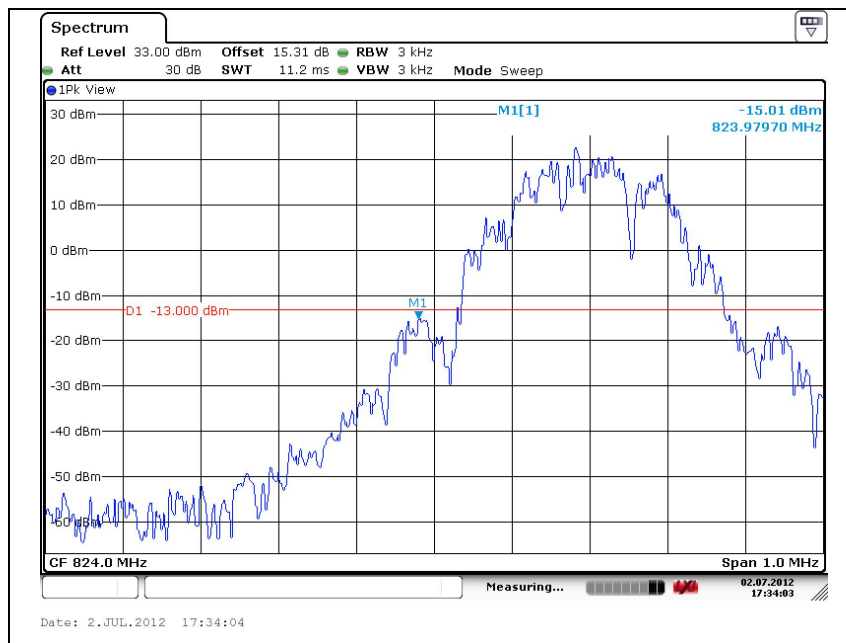

High Channel

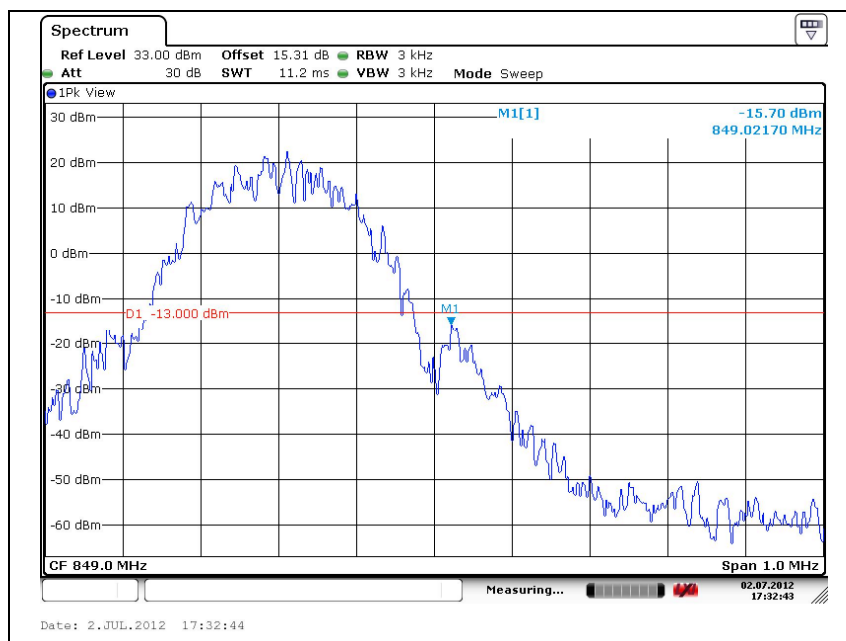

The results shown in this test report refer only to the sample(s) tested unless otherwise stated. This test report cannot be reproduced, except in full, without prior written permission of the Company.

GSM1900 Low Channel

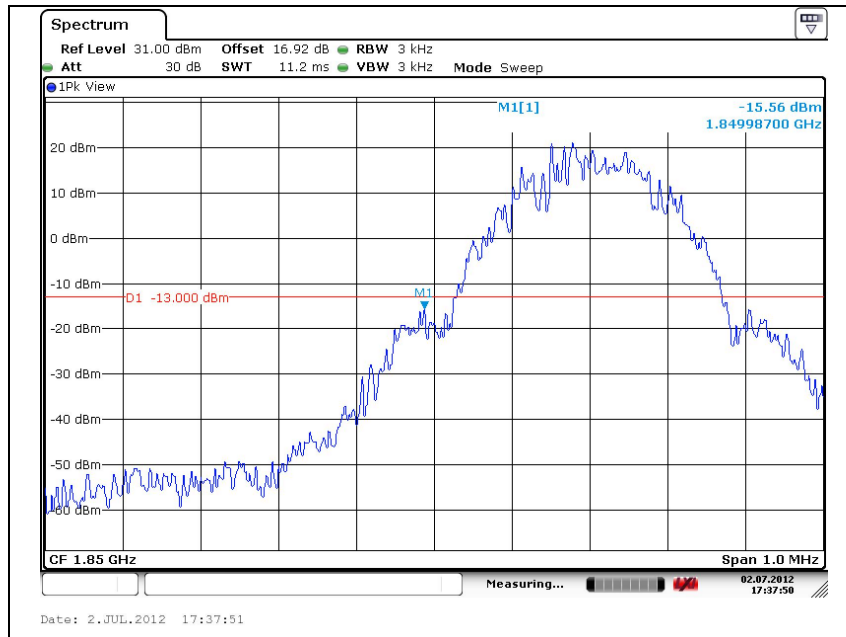

High Channel

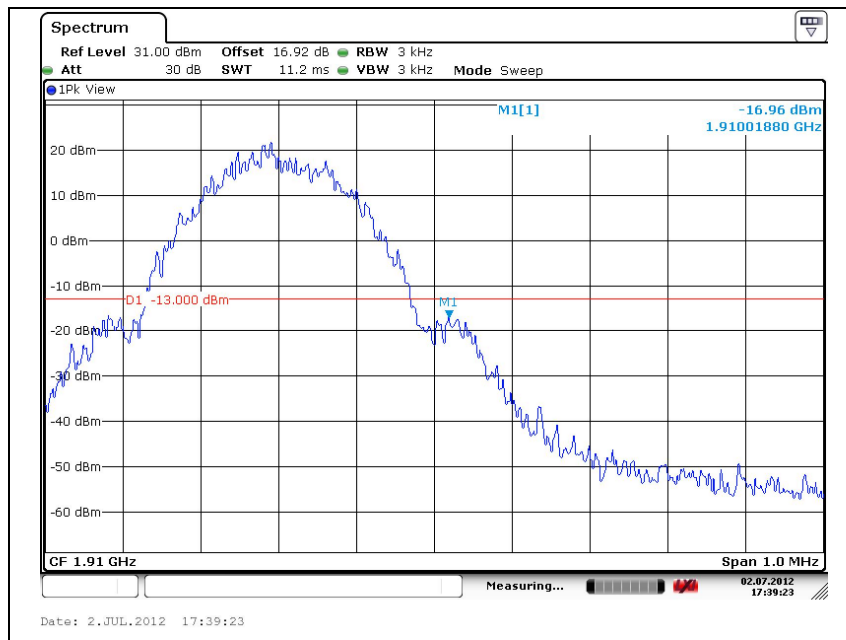

The results shown in this test report refer only to the sample(s) tested unless otherwise stated. This test report cannot be reproduced, except in full, without prior written permission of the Company.

7. Frequency Stability

7.1. Limit

Requirements: FCC § 2.1055 (a), § 2.1055 (d) & following:

According to §22.355, the carrier frequency of each transmitter in the Public Mobile Services must be maintained within the tolerances given in Table of this section.

For Mobile devices operating in the 824 to 849 MHz band at a power level less than or equal to 3 Watts, the limit specified in Table C-1 is +/- 2.5 ppm.

§24.235 The frequency stability shall be sufficient to ensure that the fundamental emission stays within the authorized frequency block.

7.2. Test Procedure

1. Frequency Stability vs. Temperature: The equipment under test was connected to an external DC power supply and the RF output was connected to a frequency counter via feed-through attenuators.
2. The EUT was placed inside the temperature chamber.
3. After the temperature stabilized for approximately 20 minutes, the frequency output was recorded from the counter.

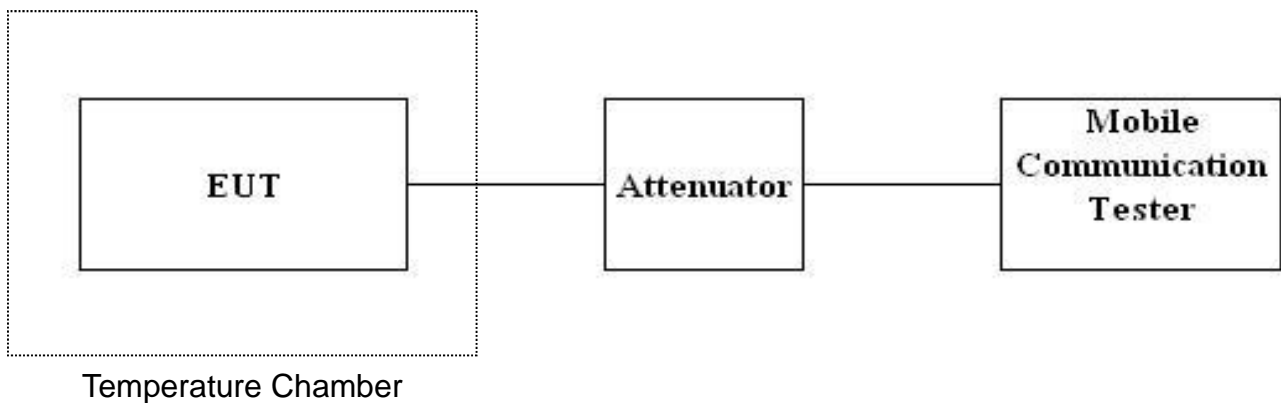

The results shown in this test report refer only to the sample(s) tested unless otherwise stated. This test report cannot be reproduced, except in full, without prior written permission of the Company.

7.3. Test Results

Ambient temperature : (24 ± 2) °C
 Relative humidity : 47 % R.H.

GSM850 mode at middle channel

Reference Frequency: 836.6 MHz, Limit: 2.5 ppm			
Frequency Stability versus Temperature			
Environment Temperature (°C)	Power Supplied (Vdc)	Frequency Measure with Time Elapse	
		Frequency Error (Hz)	ppm
50	3.7	-28	-0.015
40		-20	-0.011
30		-18	-0.010
24		-31	-0.016
10		-39	-0.021
0		-25	-0.013
-10		-21	-0.011
-20		-17	-0.009
-30		-16	-0.009
Frequency Stability versus power Supply			
Environment Temperature (°C)	Power Supplied (Vdc)	Frequency Measure with Time Elapse	
		Frequency Error (Hz)	ppm
24	4.255	-49	-0.026
	3.54(batt. End point)	-43	-0.023

The results shown in this test report refer only to the sample(s) tested unless otherwise stated. This test report cannot be reproduced, except in full, without prior written permission of the Company.

GSM1900 mode at middle channel

Reference Frequency: 1 880.0 MHz, Limit: 2.5 ppm			
Frequency Stability versus Temperature			
Environment Temperature (°C)	Power Supplied (Vdc)	Frequency Measure with Time Elapse	
		Frequency Error (Hz)	ppm
50	3.7	-35	-0.019
40		-29	-0.015
30		-27	-0.014
24		-20	-0.011
10		-18	-0.010
0		-24	-0.013
-10		-33	-0.018
-20		-41	-0.022
-30		-39	-0.021
Frequency Stability versus power Supply			
Environment Temperature (°C)	Power Supplied (Vdc)	Frequency Measure with Time Elapse	
		Frequency Error (Hz)	ppm
24	4.255	-67	-0.036
	3.54(batt. End point)	-54	-0.029

The results shown in this test report refer only to the sample(s) tested unless otherwise stated. This test report cannot be reproduced, except in full, without prior written permission of the Company.