

REV	DESCRIPTION	DSND	DATE
1	IR3和R3由200变更为240	Flyer	2013.5.4
2	3R4由68k变更为100k		
3	增加电阻R6和PS3LED改为背光	Flyer	2013.5.8

SCH		DSND	Flyer	DATE	2013-05-08	
CHKD				DATE		
APPR				DATE		PART No.: 125-0012400R
REV.	C	Requirement:				MODEL NAME: CA-3092BT
Modification	2					DRAWING No.: S125-0012400R
Page	5/5					

2.402-2.480GHZ

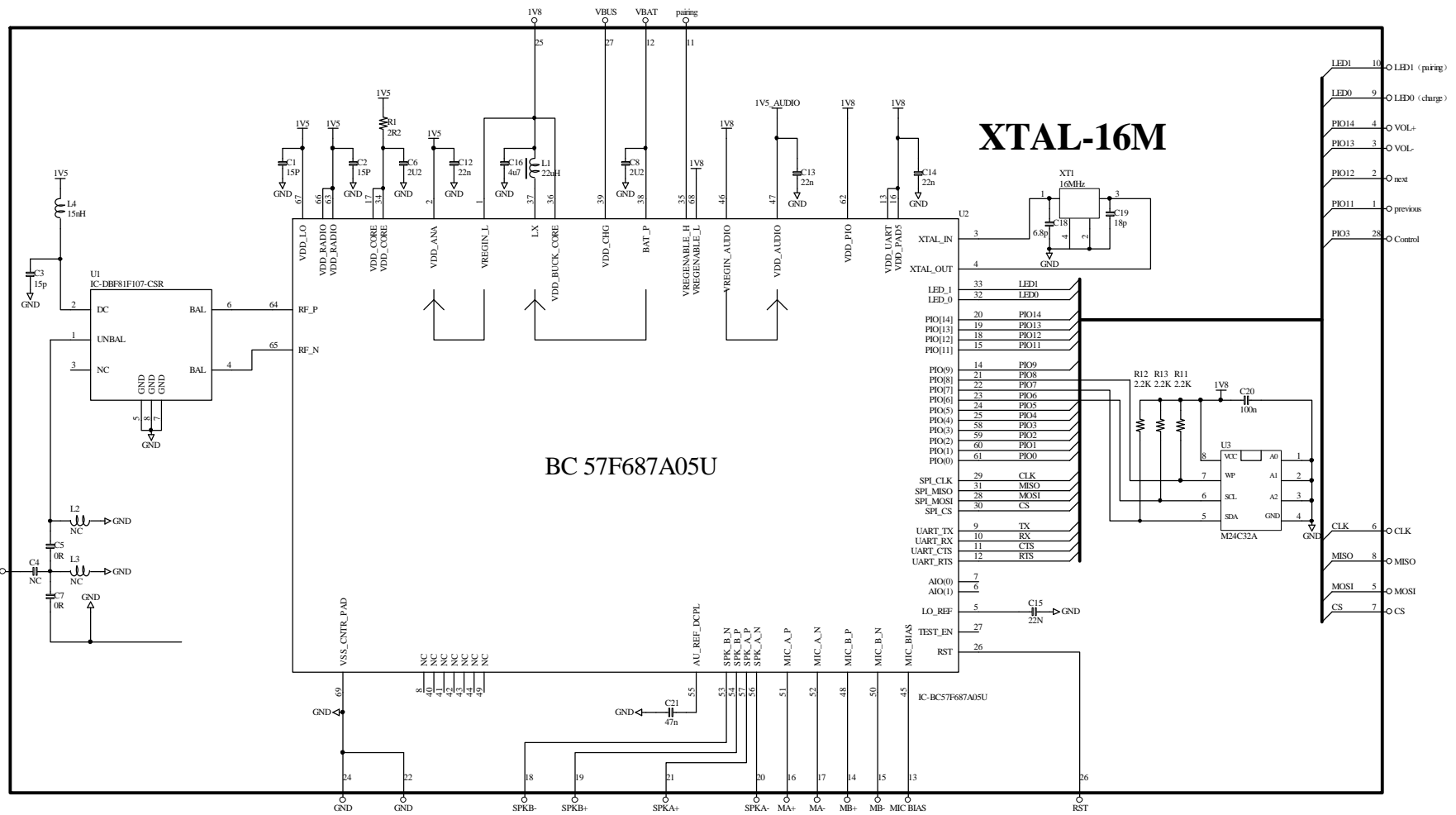

bluetooth module-1

SCH	拟制	日期	13-04-25	
	审核	日期		
版本	批准	日期		零件名称: BTBC05M100
修改状态	要求:			零件编号:
第 页 共 页				机种名称:
				文件编号: