

Ringway

■ Digital Piano

■ **DP-3**

User's Manual

Precaution

Thank you for purchasing this digital instrument. For perfect operation and security, please read the manual carefully and keep it for future reference.

Safety Precautions



The lightning flash with arrowhead symbol within an equilateral triangle is intended to alert the user to the presence of uninsulated “dangerous voltage” within the product's enclosure that may be of sufficient magnitude to constitute a risk of electric shock to persons.



The exclamation point within an equilateral triangle is intended to alert the user to the presence of important operating and maintenance (servicing) instructions in the literature accompanying the product.

Important Safety Instructions



(Figure 1)

- 1) Read these instructions.
- 2) Keep these instructions.
- 3) Heed all warnings.
- 4) Follow all instructions.
- 5) Do not use this apparatus near water.
- 6) Clean only with dry cloth.
- 7) Do not block any ventilation openings, install in accordance with the manufacturer's instructions.
- 8) Do not install near any heat sources such as radiators, heat registers, stoves, or other apparatus (including amplifiers) that produce heat.
- 9) Do not defeat the safety purpose of the polarized or grounding-type plug. A polarized plug has two blades with one wider than the other. A grounding type plug has two blades and a third grounding prong. The wide blade or the third prong are provided for your safety, if the provided plug does not fit into your outlet, consult an electrician for replacement of the obsolete outlet.
- 10) Protect the power cord from being walked on or pinched particularly at plugs, convenience receptacles, and the point where they exit from the apparatus.
- 11) Only use attachments/accessories specified by the manufacturer.
- 12) Use only with the cart, stand, tripod, bracket, or table specified by the manufacturer, or sold with the apparatus. When a cart is used, use caution when moving the cart/apparatus combination to avoid injury from tip-over (Figure 1).
- 13) Unplug this apparatus during lightning storms or when unused for a long period of time.
- 14) Refer all servicing to qualified service personnel. Servicing is required when the apparatus has been damaged in any way, such as power-supply cord or plug is damaged, liquid has been spilled or objects have fallen into the apparatus, the apparatus has been exposed to rain or moisture, does not operate normally, or has been dropped.

WARNING: To reduce the risk of fire or electric shock, do not expose this apparatus to rain or moisture.

CAUTION: Apparatus shall not be exposed to dripping or splashing and no objects filled with liquids, such as vases, shall be placed on the apparatus.

WARNING: This product contains chemicals, including lead, known to the State of California to cause cancer, and birth defects or other reproductive harm. Wash hands after handling.

Thank you for choosing the Digital Piano

Your piano is a high quality digital piano featuring an 88 note hammer action, touch sensitive keyboard and the most advanced PCM tone generation technology that combined will provide you with a rich performing and playing experience. You can also record your own performances or record your own accompaniment to play along to. The piano is more than great technology, your digital piano is also a stylish piece of furniture that will look great anywhere in your home. To get the most out of your instrument, please read this manual thoroughly and try out the various functions as we take you through them. We hope your new instrument will continue to entertain you for many years to come.

Contents

Panel Control	1
Setup	3
Basic Operation	4
Standby/On	4
AutoStandby	4
Deactivate Auto standby Function	4
Adjusting Volume & Start Playing	4
Piano Pedals	4
Piano Reset	5
Playing Demo Songs	6
The Connector Box	7
Headphones	7
MIDI OUT	7
Line Out	8
Using USB MIDI/USB Audio	8
Aux In	8
Voice/Effect	9
Selecting a Voice	9
Layer Button	9
Split Button	10
Reverb	10
Chorus	11
Duet	11
Metronome	12
Touch	12
Set Up	14
Song Recording	21
Start recording	21
Stop recording	21
Listen to your recording	21
Track Clear	22
Learning Function	23
Selecting a song	23
Listening to the entire song	23
Practicing the right hand of the selected song	24
Practicing the left hand of the selected song	24
Practicing the both hand of the selected song	24
MIDI functions	25
Local On/Off	25
Appendix	26
MIDI Implementation Chart	26
Voice List	27
Factory List	28
Specifications	29
Assembly Instructions	30

Panel Control

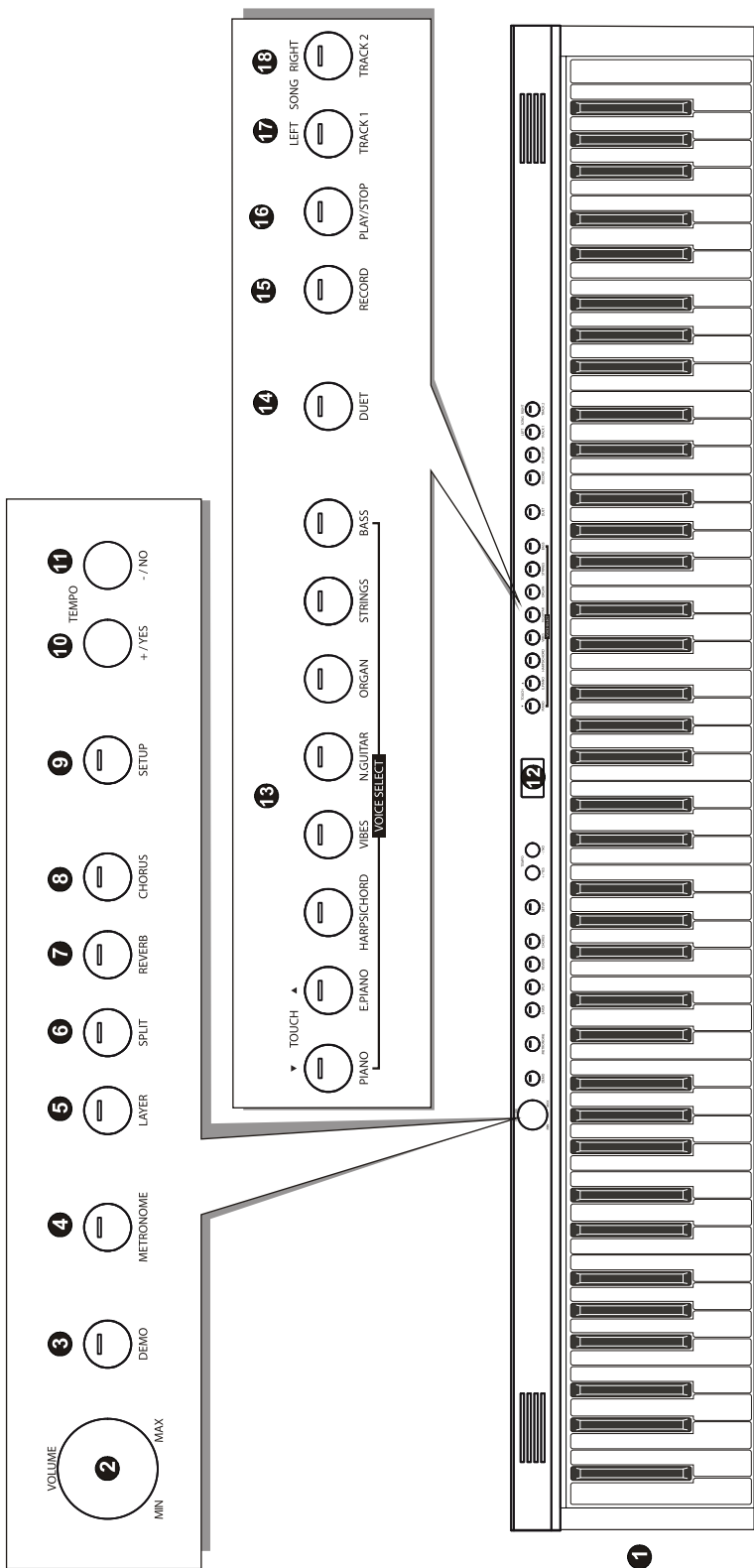

Rear Panel

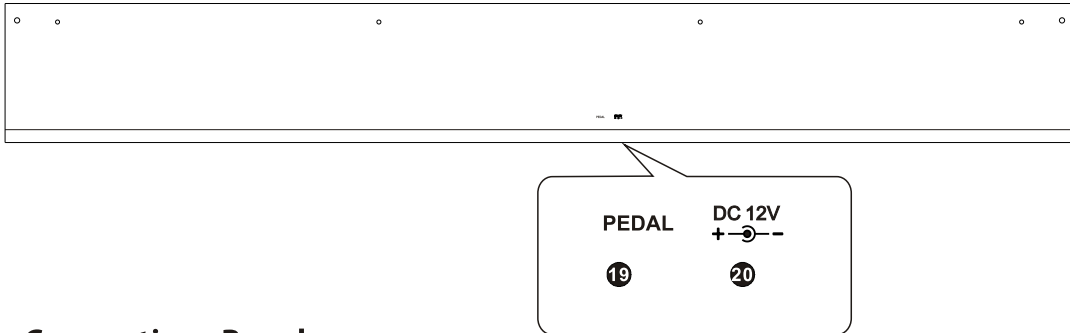

Connections Panel

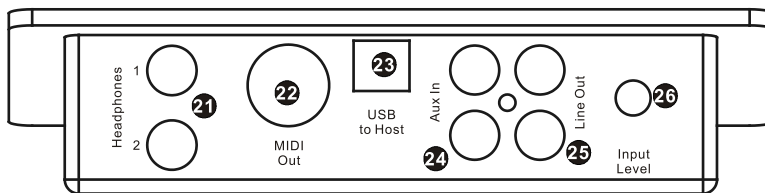

Front Panel

1. STANDBY /ON button
2. VOLUME Data Control knob
3. DEMO button
4. METRONOME button
5. LAYER button
6. SPLIT button
7. REVERB button
8. CHORUS button
9. SETUP button
10. +/YES button
11. -/NO button
12. LDC display
13. Voice Select buttons
14. DUET button
15. Record button
16. PLAY/STOP button
17. LEFT/TRACK 1 button
18. RIGHT/TRACK 2 button

Rear Panel

19. Pedal Connector
20. DC 12V

Connections Panel

21. Headphones 1 / 2
22. MIDI Out
23. USB to Host Connector
24. Aux Line In
25. Line Out
26. Aux Input Level

Setup

You are no doubt eager to play your new piano instrument, but first please make sure you have completed the following basic setup steps:

- 1) Follow the assembly instructions as outlined on page 30 in the appendix of this manual.
- 2) Once the piano is securely assembled, connect the plug of the foot pedal unit to the pedal jack on the rear panel.

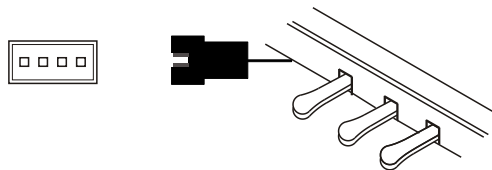

- 3) Plug the other end of the power cable into the power outlet.

NOTE

1. Ensure the piano is turned off when connecting and disconnecting the power.
2. Turn the volume knob to its minimum level before turning on the power.

Basic Operation

Standby/On

Press the [STANDBY/ON] button to turn on the power and the LCD display will light.

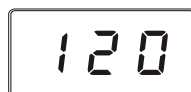

Auto Standby

Your piano will switch off automatically in 30 minutes after no any operation on it. In this case, press the [STANDBY/ON] button again to turn on the power.

Deactivate Auto Standby Function

Hold the first white key and first black key on the left side of the keyboard at the same time and then press the [STANDBY/ON] button to deactivate the Auto Standby function.

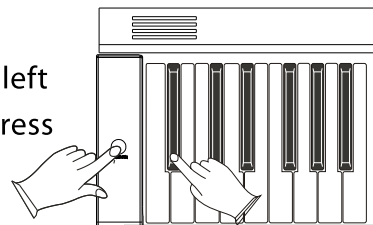

Adjusting Volume & Start Playing

The speaker system in the piano is very powerful and can be overpowering in some rooms. Adjust the [VOLUME] control to a 12 o'clock position as a safe starting point. You can adjust the volume at any time even while you are playing.

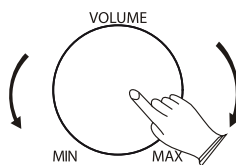

Now play the keyboard. You should hear the rich tone of the default Grand Piano sound.

Piano Pedals

Just like a regular grand piano, your piano feature 3 foot pedals:

Damper Pedal (Right)

The damper pedal performs the same function as the damper pedal on an actual acoustic piano, letting you sustain the sound of the voices even after releasing your fingers from the keys.

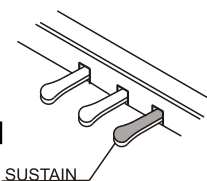

Sostenuto Pedal (Center)

The sostenuto pedal also allows you to sustain notes, but it works a little different from the damper pedal. If you play a note or chord on the keyboard and press the sostenuto pedal while the notes are held, those notes will be sustained as long as the pedal is held. All subsequently played notes will not be sustained.

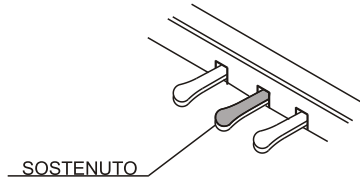

Soft Pedal (Left)

The soft pedal on an acoustic piano changes the character of the sound, making it softer and quieter. The soft pedal on your piano does exactly the same. Press the soft pedal when you need to play passages that require extreme pianissimo.

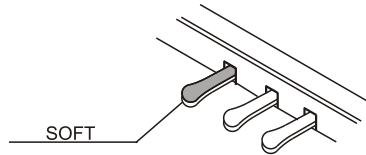

Playing Demo Songs

There are 8 demo songs for you to play individually. Here's how to select and play the demo songs.

■ Listen to Demo Songs

Press the [DEMO] button to enter Demo Mode.

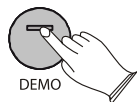

The display will show “0.0.1,” and the button will flash, then the demo songs will play in sequence. You can use the [+ / YES] / [- / NO] buttons to select the song you want to play.

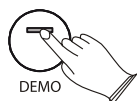

Press the [DEMO] button again to stop playing.

[+ / YES] & [- / NO]

Parameter adjusting button.

The Connector Box

Headphones

The piano is equipped with two sets of standard stereo headphone jacks to accommodate private practice or late-night playing. The internal speaker system is automatically shut off when a pair of headphones is plugged into the 1. Headphone jack.

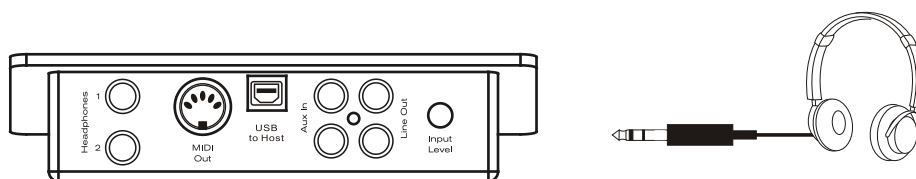

MIDI OUT

MIDI (Musical Instrument Digital Interface) is a world-standard communication interface which allows electronic musical instruments to communicate with each other, by sending and receiving compatible note, program change and other types of MIDI data. You should only plug the MIDI out in to another device featuring a MIDI input.



NOTE

MIDI OUT Transmits MIDI data to another MIDI device.

Line OUT

The piano's stereo RCA line output can be used to deliver the output of the piano to a keyboard amplifier, stereo sound system, mixing console or tape recorder. The piano's internal sound system will remain on unless headphones are plugged in to the 1. Headphone jack.

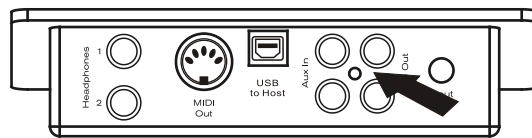

Using USB-MIDI/USB Audio

This product allows the transfer of MIDI information over USB to a computer. As complicated this might sound, it's actually pretty straight forward. Because your piano is USB Class Compliant, there is no need to install a driver to enable it to work with compute. Simply just plug it in and the OS will do the rest. The piano will work with all standard MIDI based computer software.

USB AUDIO interface is a digital audio interface. By USB cable, you can digitally transfer intact audio signals of PC to this instrument, and enjoy it on this instrument or use it for accompany when you play this instrument; likewise, you can transfer intact audio signals of the instrument to PC to record and edit music.

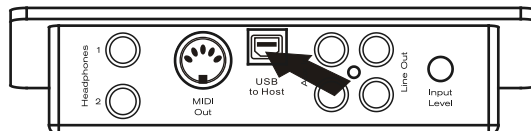

Aux In

The Aux In stereo RCA connectors allow you to mix an external sound source (such as a CD player, MP3 player or computer output) with the piano's internal sounds, for playback through the piano's built-in speakers or headphone outputs.

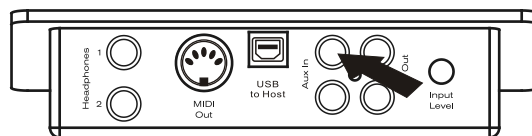

The Aux In signal level can be adjusted using the Input Level knob.

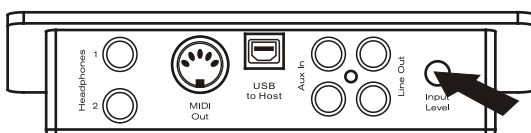

Voice/Effect

The piano has 8 voices and a variation of each voice pattern to choose from. There is a complete list of all 8 voices.(Reference: Appendix (Voice List)P58)

Selecting a Voice

Select the desired voice by pressing the appropriate **VOICE** button.

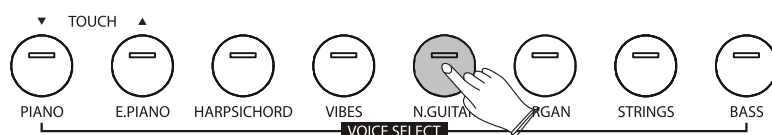

The digital piano has 8 direct-selecting voice buttons.

When pressing a voice button, the assigned voice number is shown on the display and the button will light.

You can change the voice of the selected button pressing the other voice button.

Layer Button

In Layer mode two voices may be played simultaneously, each at selected volumes. To enter Layer mode by either of two methods: a. Press the [LAYER] button and the indicator is flashing, then press the voice button to select the second voice.

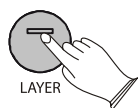

b. In Layer mode, press the [LAYER] button and hold 2 seconds and the indicator is flashing, then press the voice button to select the second voice. You should press the [LAYER] button again to enter Layer mode.

If you don't choose the layer voice within 5 seconds after entering the Layer mode, it will quit this menu automatically.

When the Layer indicator is unlighted, then press the voice select button to select the Main voice.

Split Button

Press the [SPLIT] button to select split mode, your keyboard will be split into two sections which means different voices can be played with the left and right hands at the same time.

In Split mode, press the [SPLIT] button, the Split indicator is flashing, then press the voice select button to select the left hand voice.

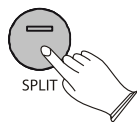

If you don't choose the left voice within 5 seconds after entering the split mode, it will quit this menu automatically.

When the Split indicator is unlighted, then press the voice select button to select the Main voice.

Press [SPLIT] again, the Split indicator turns off and the Split mode is no longer active.

Reverb

The [REVERB] button selects a number of digital reverb effects that you can use for extra depth and expressive power.

Press the [REVERB] button can turn on or turn off the reverb effect.

(Default: 5Room3)

When the reverb mode is turned off, you can press the [REVERB] button again and then use the [+ / YES] and [- / NO] buttons to select reverb type.

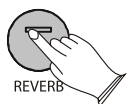

The reverb types in the list below can be selected from the reverb display.

0	1	2	3	4	5	6	7	8
Off	Hall1	Hall2	Room1	Room2	Room3	Stage 1	Stage2	Plate

Reverb Level: Referenec:P16.

Chorus

Shimmering, broadening effect.

Press the [REVERB] button can turn on or turn off the reverb effect.(Default:02)

When the chorus mode is turned off, you can press the [CHORUS] button again and then use the [+ /YES] and [- /NO] buttons to select chorus type.



The chorus types in the list below can be selected from the chorus display.

0	1	2	3	4	5	6	7	8
off	Chorus1	Chorus2	Chorus3	Feedback	Flanger1	ShortDelay	ShortDe- layFb	Flanger2

Chorus Level: Referenec:P17.

DUET

Press the [DUET] button to select DUET mode. In this mode, the keyboard will be separated into two playing areas.

Right: from C#3 to C7

Left: from A-1 to C3

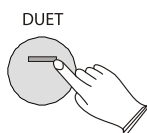

This will be very helpful when the instrument is used by two players at the same time and they will be able to play the same piano sound in the same octave.

Press [DUET] button again to exit the DUET mode.

While the DUET feature is selected using the optional 3 lever pedal, the pedals automatically switch in a different configuration where there are 2 Sustain pedals, one for the left and one for the right part of the keyboard.

Metronome

Metronome is a convenient feature for practice, and it can also provide a solid rhythmic guide when recording.

Press the [METRONOME] button can turn off or turn on the Metronome mode.

● Time signature

Hold down the [METRONOME] button and then use the [+ / YES] and [- / NO] buttons to be set the time signature of the metronome .

Time signature: 2/2, 1/4, 2/4, 3/4, 4/4, 5/4, 6/4, 3/8, 6/8, 7/8, 9/8, 12/8.

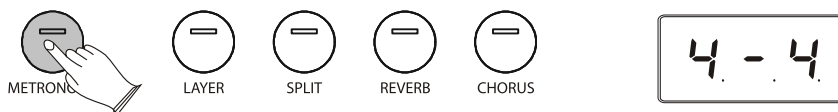

● Adjusting the Metronome Tempo

Press the [+ / YES] / [- / NO] button at the same time to enter the tempo setting mode, then use the [+ / YES] / [- / NO] button to change the tempo value range from 20 to 280 BPM (beats per minute).



Touch

The touch function provides three different types of keyboard touch sensitivity and you may match them with different playing styles: Normal, Soft , Hard (Default: 00Normal).

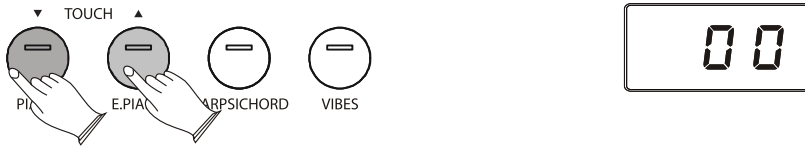

You press the [TOUCH ◀/▶] button to turn touch sensitivity on.
You can use the [+ /YES] and [- /NO] buttons to select the touch type.
Range:00-03. (Default: 00)

Set Up

Press the [SET UP] button repeatedly to select the function, see the table below:

Function	LCD Display	Range	Default
Main Voice Volume	F01	00-127	127
Split Voice Volume	F02	00-127	127
Layer Voice Volume	F03	00-127	65
Metronome Voice Volume	F04	00-127	100
Reverb Type	F05	00-08	05
Reverb Level	F06	00-63	18
Chorus Type	F07	00-08	00
Chorus Level	F08	00-63	18
Tune	F09	-64-63	00
Transpose	F10	-12-12	00
Local	F11	On/Off	On
EQ Bass	F12	-06-06	00
EQ Treble	F13	-06-06	00
Song Grading	F14	On/Off	On
Reset	F15		

● Main Voice Volume

In this function you can set the Main Voice Volume.

Press the [SETUP] button repeatedly to select “F01” , then use the [+ /Yes] and [- /No] buttons increase or decrease the value. Range: 00 ~127.

(Default:127)



● Split Voice Volume

In this function you can set the Split Voice Volume.

Press the [SETUP] button repeatedly to select “F02” , then use the [+ /Yes] and [- /No] buttons increase or decrease the value. Range: 00 ~127.

(Default: 127)



● Dual Voice Volume

In this function you can set the Dual Voice Volume.

Press the [SETUP] button repeatedly to select “F03” , then use the [+ /Yes] and [- /No] buttons increase or decrease the value. Range: 00 ~127.

(Default: 65)



● Metronome Volume

In this function you can set the Metronome Volume.

Press the [SETUP] button repeatedly to select “F04” , then use the [+ /Yes] and [- /No] buttons increase or decrease the value. Range: 00 ~127.

(Default:127)

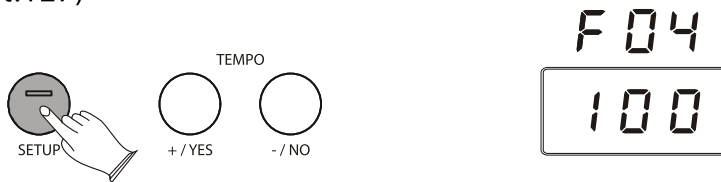

● Reverb Type

Press the [SETUP] button repeatedly to select “F05” , then use the [+ /Yes] and [- /No] buttons to select the desired Reverb Type. Range: 00~08.

(Default:05)

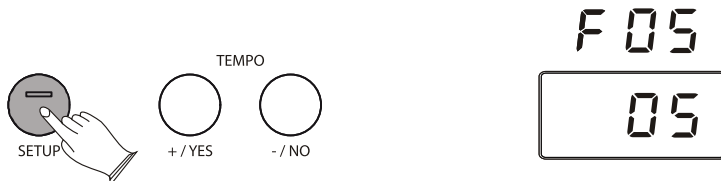

No reverb effect is produced when you select “00 Reverb” .

● Reverb Level

This function allows you to adjust the reverb depth for the voice section.

Press the [SETUP] button repeatedly to select “F06” , then use the [+ /Yes] and [- /No] buttons to adjust the value. Range: 00-63. (Default:18)

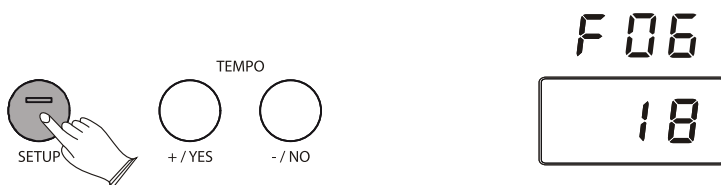

● Chorus Type

Press the [SETUP] button repeatedly to select “F07” , then use the [+ /Yes] and [- /No] buttons to select the desired Chorus Type. Range: 00~08. (Default:00)

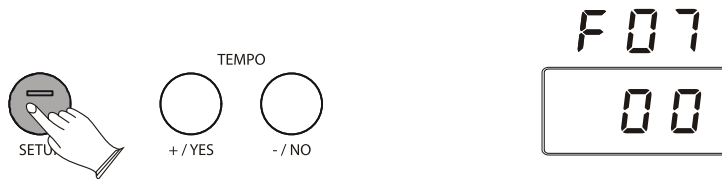

No chorus is produced when you select “00 Chorus” .

● Chorus Level

This function allows you to adjust the chorus depth for the voice section.

Press the [SETUP] button repeatedly to select “F08” , then use the [+ /Yes] and [- /No] buttons to adjust the value. Range: 00-63. (Default:18)

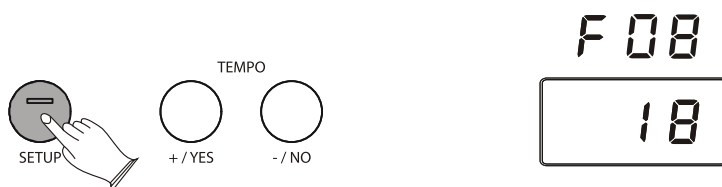

● Tune

The function makes it possible to tune the pitch of your piano to match other piano.

Press the [SETUP] button repeatedly to select “F09” , then use the [+ /Yes] and [- /No] buttons to adjust the value. Range:-64-63. (Default:00)

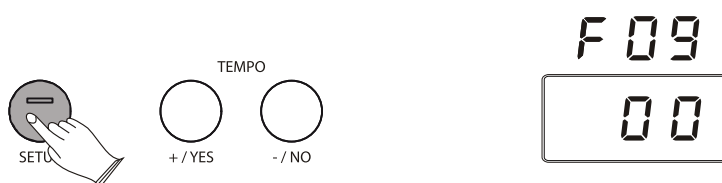

● Transpose

The Transpose function allows you to change the pitch of the piano in semitone steps, up to a maximum setting of 12 semitones (a maximum of one octave up or down).

Press the [SETUP] button repeatedly to select “F10” , then use the [+ /Yes] and [- /No] buttons to adjust the value. Range:-12-12. (Default:00)

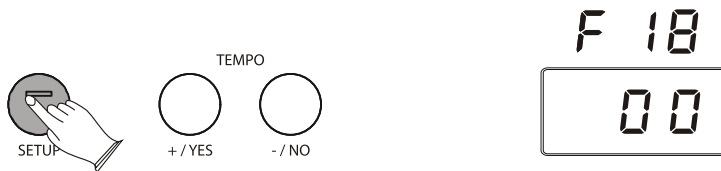

● Local

Using this function, you can turn of the keyboard internal sound generator, but still have the MIDI data being sent out.

Press the [SETUP] button repeatedly to select “F11” , then use the [+ /Yes] and [- /No] buttons to turn on or turn off the function. (Default:0n)

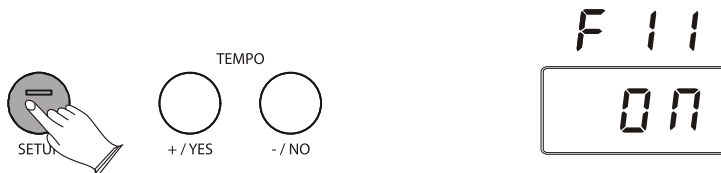

Local on----- Normal operation. Keyboard and Controllers are sent to the Sound Engine. Keyboard plays normally.

Local off----- There will be no sound produced by the keyboard s own tone generation system. MIDI function will continue to work as usual.

● EQ Bass

This function allows you to set the EQ Bass for the voice.

Press the [SETUP] button repeatedly to select “F12”, then use the [+ / Yes] and [- / No] buttons to adjust the value. Range: -06~06. (Default:00)

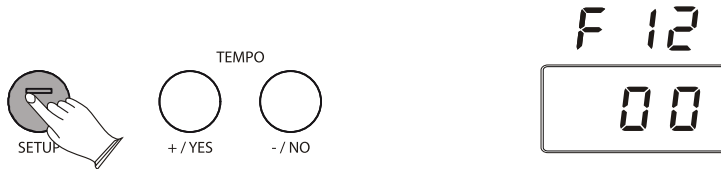

● EQ Bass

This function allows you to set the EQ Treble for the voice.

Press the [SETUP] button repeatedly to select “F13”, then use the [+ / Yes] and [- / No] buttons to adjust the value. Range: -06~06. (Default:00)

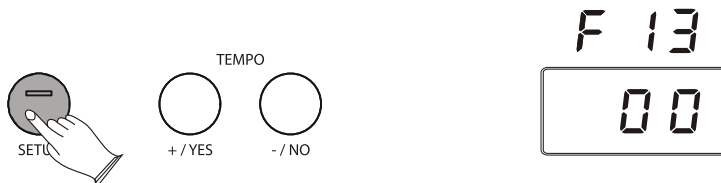

● Song Grading

This function is in the song learning mode, when playing songs, it will automatically score based on your performance.

Press the [SETUP] button repeatedly to select “F14”, then use the [+ / Yes] and [- / No] buttons to turn on or turn off the function. (Default:On)

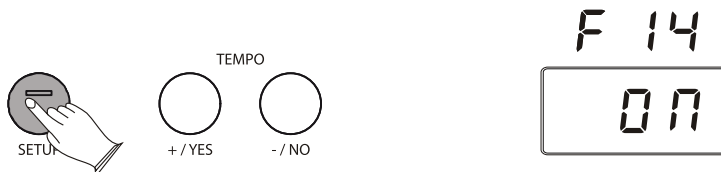

● Reset

Press the [SETUP] button repeatedly to select “F15” , then use the [+ / Yes] and [- / No] buttons to reset the piao.

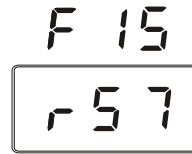
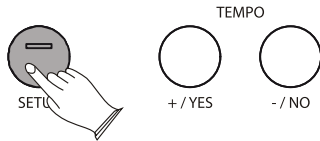

Song Recording

Recording function lets you record your performances using up to two independent tracks. The recorded data will not be lost when you turn off the power.

Start Recording

Hold down the [RECORD] button, and then press [TRACK-1] or [TRACK-2] button to enter recording mode, the [RECORD] button indicator is lighted, and [TRACK-1] or [TRACK-2] button indicator flashes. Play the keyboard to start the recording.



Stop Recording

Press the [RECORD] button again to stop recording.

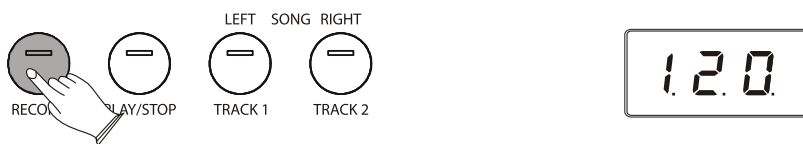

Note: If the other track has data recorded, it will play when the record is started. You also can press the track button to mute it.

Listen to Your Recording

To play the song from the beginning, simply press the [PLAY/STOP] button. Playback stops when the [PLAY/STOP] button is pressed again.

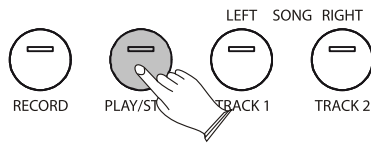

Track Clear

Hold down the [RECORD] button and then press [PLAY/STOP] button to clear all recording data.

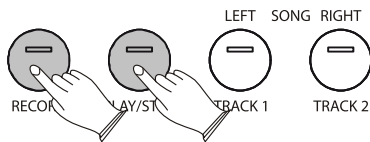

Learning Function

There are 55 songs built into this Piano for your musical enjoyment. These songs have separate left and right-hand parts that can be turned on and off as required so you can practice the corresponding part on the piano.

Selecting A Song

Turn on the song mode by pressing both the [LEFT] and [RIGHT] buttons simultaneously. The [PLAY/STOP] button will flash.

The song number will appear on the LCD display.

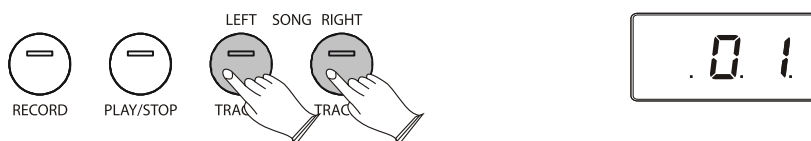

Use the [- /NO] / [+ /YES] buttons to select a song. Press the [PLAY/STOP] button to start the song.

Listening To The Entire Song

1). With the play along song mode engaged, press the [PLAY/STOP] button to hear both hand parts playing the entire song.

2). Press the [PLAY/STOP] button again to stop. Otherwise, playback will stop automatically at the end of the song.

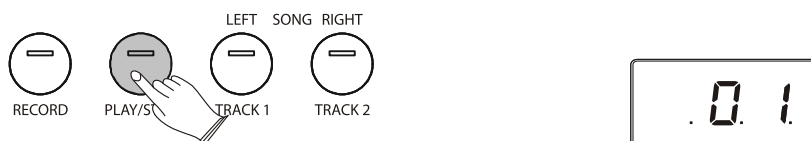

Practicing The Right Hand Of The Selected Song

1). Both Right and Left button are light. Press the [RIGHT] button to mute the right hand part.

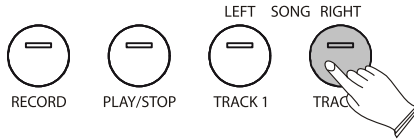

2). Press the [PLAY/STOP] button. Then you will hear the song. You will then hear the left-hand part.

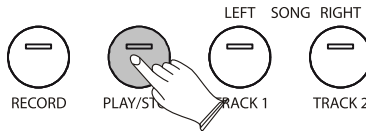

3). Play the right-hand part of your selected song while the left-hand part plays.

4). Press the [PLAY/STOP] button again to stop. Otherwise, playback will stop automatically at the end of the song.

Practicing The Left Hand Of The Selected Song

Follow steps 1-4 listed above, substituting the [LEFT] button whenever the [RIGHT] button is mentioned. You will hear the right-hand part of your selected song. Play the left-hand part of your selected song while the right-hand part plays.

Turn off the Learning Function

Press the both [LEFT] and [RIGHT] buttons again to turn off the learning mode.

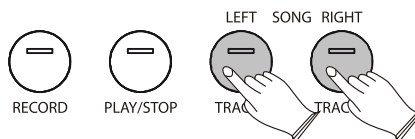

MIDI Function

If you are an advanced MIDI user, this section will help you to access the MIDI controller capabilities of the piano. If you already know that you need this specialized functionality, then this section is for you. However, this information is not necessary in order to enjoy playing the piano. A good rule to keep in mind is: If you don't know what a function described in this section is, then you probably don't need it.

MIDI, or Musical Instrument Digital Interface, is the way most electronic keyboards communicate with computers and with each other. Through a series of MIDI messages a computer or keyboard can tell an instrument what note to play, how loud to play it, when to stop playing it, and a host of other information.

The piano can send MIDI information to a computer or another MIDI-capable instrument, via its MIDI or USB output. This enables the piano to act as a controller keyboard for another instrument, MIDI sequencer or MIDI enabled Digital Audio Workstation program.

Local On/Off

Turning the Local On/Off function to Off will disconnect the keyboard from the internal sound engine of the piano. This means you can use the piano as a MIDI controller to control other MIDI devices (or virtual instrument software running on your computer) without playing the internal sounds of the piano.

You may also find other occasions (such as when you are using MIDI sequencing software on your computer) where it is useful to turn Local off.

Turn Local On/Off to Off

Please refer to [SETUP] function, see page 20.

Turn Local On/Off to On

Please refer to [SETUP] function, see page 20.

Appendix

MIDI Implementation Chart

Function		Transmitted	Recognized	Remarks
Basic Channel	Default	1-16	1-16	
	Changed	1-16	1-16	
Mode	Default	Mode 3	Mode 3	
	Messages	O	X	
	Altered	*****	X	
Note Number	True voice	0~127 *****	0~127	
Velocity	ON	O	O	
Note	OFF	O	O	
After Touch	Key's Touch Channel	X X	X X	
Pitch Bend		X	X	
Control Change		0-127	0,1,5,6,7,10,11, 32,64,65,66,67, 80,81,91,93,100, 101,121	
Program Change	True #	0-127 *****	0-7	*8 sounds only PGM=0-7
System Exclusive		O*	O*	*The controller will recognize and respond to GM Device inquiries. Master Tune supported. Master Volume supported.
System Common	Song Position Pointer	X	X	
	Song Select	X	X	
	Tune Request	X	X	
System Real Time	Clock Commands	X X	X X	
Aux Messages	All Sounds Off*	O	O	
	Reset All Controllers	O	O	
	Local ON/OFF*	O	O	
	ALL Notes OFF	O	O	
	Active Sensing	X	O	
	System Reset	X	O	
Notes				

Mode1:OMNI ON,POLY Mode2:OMNI ON,MONO O: Yes
 Mode3:OMNI OFF,POLY Mode4:OMNI OFF,MONO X: NO

Voice List

NO.	Voice Name
01	PIANO
02	E.PIANO
03	HARPSICHORD
04	VIBES
05	N.GUITAR
06	ORGAN
07	STRINGS
08	BASS

Factory Reset

Press the [SETUP] button repeatedly to select “F15”, then use the [+ / Yes] and [- / No] buttons to reset the piano.



2. Press the [+ / YES] and [- / NO] button and hold down the [STANDBY / ON] button to turn on the piano, then all settings are restored.



Specifications

Keyboard:

88 Notes Graded Hammer Action

Display:

LCD Display

Voice:

8

Polyphony:

64

Voice Control:

Layer, Split, Touch, Duet,

Transpose, Tune

Pedals:

Soft, Sostenuto, Sustain

Effect:

Reverb, Chorus

Demo Song:

8

Midi:

Transmit Settings

Receive Settings

Local Control

USB MIDI

Connectors:

MIDI Out, Pedal, Aux In, Line Out,

Phones1, Phones2, USB to Host,

Input Level

Speaker:

YD166-5-6F80C-R

Dimensions(W × D × H)

1360mmX384mmX775mm

Weight:

42Kg

Assembly Instructions

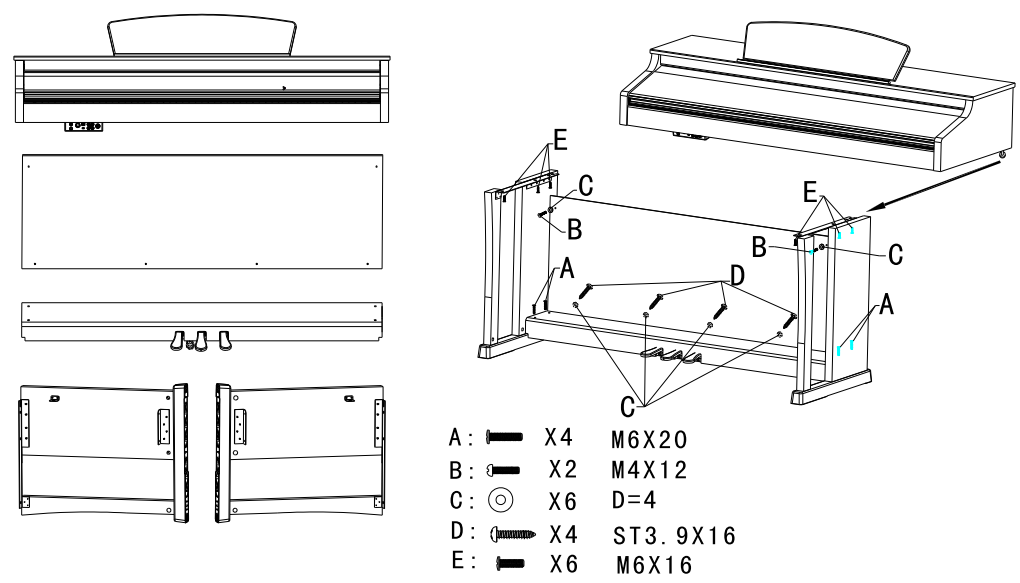

Turn the adjustable Pedal Board support, until it is in firm contact with the floor.

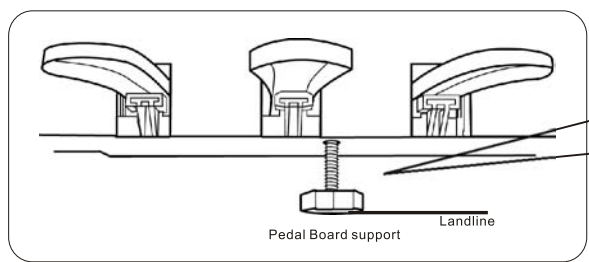

Before moving the piano to a new location, always remember to raise the level of the Pedal Board support so that it is not touching the floor. Once the piano is in place, you can adjust it so it is in firm contact with the floor again.

FCC STATEMENT

1. This device complies with Part 15 of the FCC Rules. Operation is subject to the following two conditions:

- (1) This device may not cause harmful interference.
- (2) This device must accept any interference received, including interference that may cause undesired operation.

2. Changes or modifications not expressly approved by the party responsible for compliance could void the user's authority to operate the equipment.

NOTE: This equipment has been tested and found to comply with the limits for a Class B digital device, pursuant to Part 15 of the FCC Rules. These limits are designed to provide reasonable protection against harmful interference in a residential installation. This equipment generates uses and can radiate radio frequency energy and, if not installed and used in accordance with the instructions, may cause harmful interference to radio communications. However, there is no guarantee that interference will not occur in a particular installation. If this equipment does cause harmful interference to radio or television reception, which can be determined by turning the equipment off and on, the user is encouraged to try to correct the interference by one or more of the following measures:

Reorient or relocate the receiving antenna.

Increase the separation between the equipment and receiver.

Connect the equipment into an outlet on a circuit different from that to which the receiver is connected.

Consult the dealer or an experienced radio/TV technician for help.

