

TEST REPORT

Test report no.: 1-4592_22-01-03

BNetzA-CAB-02/21-102

Testing laboratory

CTC advanced GmbH

Untertuerkheimer Strasse 6 – 10

66117 Saarbruecken / Germany

Phone: + 49 681 5 98 - 0

Fax: + 49 681 5 98 - 9075

Internet: <https://www.ctcadvanced.com>

e-mail: mail@ctcadvanced.com

Accredited Testing Laboratory:

The testing laboratory (area of testing) is accredited according to DIN EN ISO/IEC 17025 (2018-03) by the Deutsche Akkreditierungsstelle GmbH (DAkkS)

The accreditation is valid for the scope of testing procedures as stated in the accreditation certificate starting with the registration number: D-PL-12076-01.

Applicant

ADC Automotive Distance Control Systems GmbH

Peter-Dornier-Str. 10

88131 Lindau / GERMANY

Phone: 08382 9699 - 0

Contact: Thomas Reitmayer

e-mail: Thomas.Reitmayer@continental-corporation.com

Manufacturer

ADC Automotive Distance Control Systems GmbH

Peter-Dornier-Str. 10

88131 Lindau / GERMANY

Test standard/s

FCC - Title 47 CFR Part 95 FCC - Title 47 of the Code of Federal Regulations; Chapter I; Part 95 - Personal Radio Services

FCC - Title 47 CFR Part 2 Frequency allocations and radio treaty matters; general rules and regulations

For further applied test standards please refer to section 3 of this test report.

Test Item

Kind of test item: **SRD for RTTT and other vehicle or fixed installation**

Model name: **ARS6-A**

FCC ID: **OAYARS6A**

Frequency: 76.0 – 77.0 GHz

Antenna: Integrated 3D antenna

Power supply: 6.5 V to 19.0 V DC by external power supply

Temperature range: -40°C to +85°C

This test report is electronically signed and valid without handwritten signature. For verification of the electronic signatures, the public keys can be requested at the testing laboratory.

Test report authorized:

Thomas Vogler
Lab Manager
Radio Communications & EMC

Test performed:

Meheza Walla
Lab Manager
Radio Communications & EMC

1 Table of contents

1	Table of contents.....	2
2	General information.....	3
2.1	Notes and disclaimer	3
2.2	Application details	3
2.3	Test laboratories sub-contracted	3
3	Test standard/s, references and accreditations	4
4	Reporting statements of conformity – decision rule	5
5	Test environment.....	6
6	Test item	7
6.1	General description	7
6.2	Additional information	7
7	Description of the test setup.....	8
7.1	Shielded semi anechoic chamber	9
7.2	Shielded fully anechoic chamber.....	11
7.3	Radiated measurements > 18 GHz	13
7.4	Radiated measurements > 50/85 GHz	13
8	Sequence of testing.....	15
8.1	Sequence of testing radiated spurious 9 kHz to 30 MHz	15
8.2	Sequence of testing radiated spurious 30 MHz to 1 GHz.....	16
8.3	Sequence of testing radiated spurious 1 GHz to 18 GHz.....	17
8.4	Sequence of testing radiated spurious above 18 GHz.....	18
8.5	Sequence of testing radiated spurious above 50/85 GHz with external mixers	19
9	Measurement uncertainty	20
10	Far field consideration for measurements above 18 GHz	20
11	Summary of measurement results	21
11.1	Summary	21
12	Measurement results	22
12.1	Radiated power.....	22
12.2	Modulation characteristics	51
12.3	Occupied bandwidth	51
12.4	Band edge compliance.....	53
12.5	Field strength of spurious emissions	54
12.6	Frequency stability	67
13	Glossary	73
14	Document history.....	74
15	Accreditation Certificate – D-PL-12076-01-05	74

2 General information

2.1 Notes and disclaimer

The test results of this test report relate exclusively to the test item specified in this test report. CTC advanced GmbH does not assume responsibility for any conclusions and generalizations drawn from the test results with regard to other specimens or samples of the type of the equipment represented by the test item.

The test report may only be reproduced or published in full. Reproduction or publication of extracts from the report requires the prior written approval of CTC advanced GmbH.

The testing service provided by CTC advanced GmbH has been rendered under the current "General Terms and Conditions for CTC advanced GmbH".

CTC advanced GmbH will not be liable for any loss or damage resulting from false, inaccurate, inappropriate or incomplete product information provided by the customer.

Under no circumstances does the CTC advanced GmbH test report include any endorsement or warranty regarding the functionality, quality or performance of any other product or service provided.

Under no circumstances does the CTC advanced GmbH test report include or imply any product or service warranties from CTC advanced GmbH, including, without limitation, any implied warranties of merchantability, fitness for purpose, or non-infringement, all of which are expressly disclaimed by CTC advanced GmbH.

All rights and remedies regarding vendor's products and services for which CTC advanced GmbH has prepared this test report shall be provided by the party offering such products or services and not by CTC advanced GmbH. In no case this test report can be considered as a Letter of Approval.

This test report is electronically signed and valid without handwritten signature. For verification of the electronic signatures, the public keys can be requested at the testing laboratory.

2.2 Application details

Date of receipt of order:	2022-05-18
Date of receipt of test item:	2023-01-20
Start of test:*	2023-01-23
End of test:*	2023-02-03
Person(s) present during the test:	-/-

*Date of each measurement, if not shown in the plot, can be requested. Dates are stored in the measurement software.



2.3 Test laboratories sub-contracted

None

3 Test standard/s, references and accreditations

Test standard	Date	Description
FCC - Title 47 CFR Part 95	-/-	FCC - Title 47 of the Code of Federal Regulations; Chapter I; Part 95 - Personal Radio Services
FCC - Title 47 CFR Part 2	-/-	Frequency allocations and radio treaty matters; general rules and regulations

Guidance	Version	Description
ANSI C63.4-2014	-/-	American National Standard for Methods of Measurement of Radio-Noise Emissions from Low-Voltage Electrical and Electronic Equipment in the Range of 9 kHz to 40 GHz
ANSI C63.10-2013	-/-	American National Standard of Procedures for Compliance Testing of Unlicensed Wireless Devices
ANSI C63.26-2015	-/-	American National Standard for Compliance Testing of Transmitters Used in Licensed Radio Services
KDB 653005 D01	v01r01 2019-04	Equipment Authorization Guidance for 76-81 GHz Radar Devices

Accreditation	Description	
D-PL-12076-01-05	Telecommunication FCC requirements https://www.dakks.de/as/ast/d/D-PL-12076-01-05e.pdf	 

FCC designation number: DE0002

4 Reporting statements of conformity – decision rule

Only the measured values related to their corresponding limits will be used to decide whether the equipment under test meets the requirements of the test standards listed in chapter 3.

The measurement uncertainty is mentioned in this test report, see chapter 9, but is not taken into account - neither to the limits nor to the measurement results. Measurement results with a smaller margin to the corresponding limits than the measurement uncertainty have a potential risk of more than 5% that the decision might be wrong."

measured value, measurement uncertainty, verdict

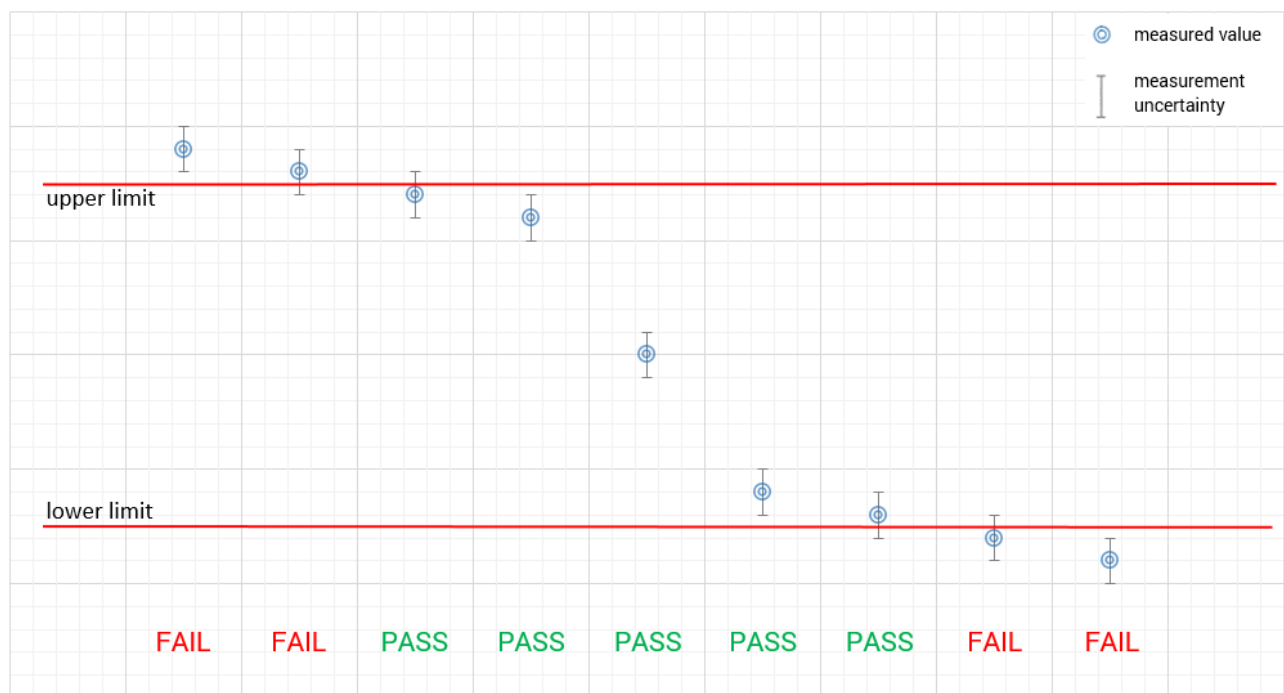

5 Test environment

Temperature	:	T_{nom}	+22 °C during room temperature tests
		T_{max}	+85 °C during high temperature tests
		T_{min}	-40 °C during low temperature tests
Relative humidity content	:		55 %
Barometric pressure	:		1021 hpa
Power supply	:	V_{nom}	12.0 V DC by external power supply
		V_{max}	19.0 V
		V_{min}	6.5 V

6 Test item

6.1 General description

Kind of test item	:	SRD for RTTT and other vehicle or fixed installation
Model name	:	ARS6-A
S/N serial number	:	A2C78207505000022311300047 (DUT 20)
Hardware status	:	B2.2
Software status	:	96.20.56
Frequency band	:	76.0 – 77.0 GHz
Type of modulation	:	FMCW
Antenna	:	Integrated 3D antenna
Power supply	:	6.5 to 19.0 V DC by external power supply
Temperature range	:	-40°C to +85°C

6.2 Additional information

Operating modes as declared by the manufacturer:

HVM_mode_ID	Fcenter [GHz]	Info	Bandwidth [MHz]
03	76.492	Operation	917.7
09		Operation	912.3
15		Operation	733.4
21		Operation	829.9
27		Operation	917.7
39		Operation	912.3
51		Operation	733.4
63		Operation	829.9
80		EoL/Service	801.0

Tests were performed on all modulations

The content of the following annexes is defined in the QA. It may be that not all of the listed annexes are necessary for this report, thus some values in between may be missing.

Test setup and EUT photos are included in test report:

- 1-4592/22-01-01_AnnexA
- 1-4592/22-01-01_AnnexB
- 1-4592/22-01-01_AnnexD

7 Description of the test setup

Typically, the calibrations of the test apparatus are commissioned to and performed by an accredited calibration laboratory. The calibration intervals are determined in accordance with the DIN EN ISO/IEC 17025. In addition to the external calibrations, the laboratory executes comparison measurements with other calibrated test systems or effective verifications. Weekly chamber inspections and range calibrations are performed. Where possible, RF generating and signaling equipment as well as measuring receivers and analyzers are connected to an external high-precision 10 MHz reference (GPS-based or rubidium frequency standard).

In order to simplify the identification of the equipment used at some special tests, some items of test equipment and ancillaries can be provided with an identifier or number in the equipment list below (Lab/Item).

Agenda: Kind of Calibration

k	calibration / calibrated		EK	limited calibration
ne	not required (k, ev, izw, zw not required)		zw	cyclical maintenance (external cyclical maintenance)
ev	periodic self verification		izw	internal cyclical maintenance
Ve	long-term stability recognized		g	blocked for accredited testing
v!k!	Attention: extended calibration interval			
NK!	Attention: not calibrated		*)	next calibration ordered / currently in progress

7.1 Shielded semi anechoic chamber

The radiated measurements are performed in vertical and horizontal plane in the frequency range from 30 MHz to 1 GHz in semi-anechoic chambers. The EUT is positioned on a non-conductive support with a height of 0.80 m above a conductive ground plane that covers the whole chamber. The receiving antennas are conform to specifications ANSI C63. These antennas can be moved over the height range between 1.0 m and 4.0 m in order to search for maximum field strength emitted from EUT. The measurement distances between EUT and receiving antennas are indicated in the test setups for the various frequency ranges. For each measurement, the EUT is rotated in all three axes until the maximum field strength is received. The wanted and unwanted emissions are received by spectrum analyzers where the detector modes and resolution bandwidths over various frequency ranges are set according to requirement ANSI C63.

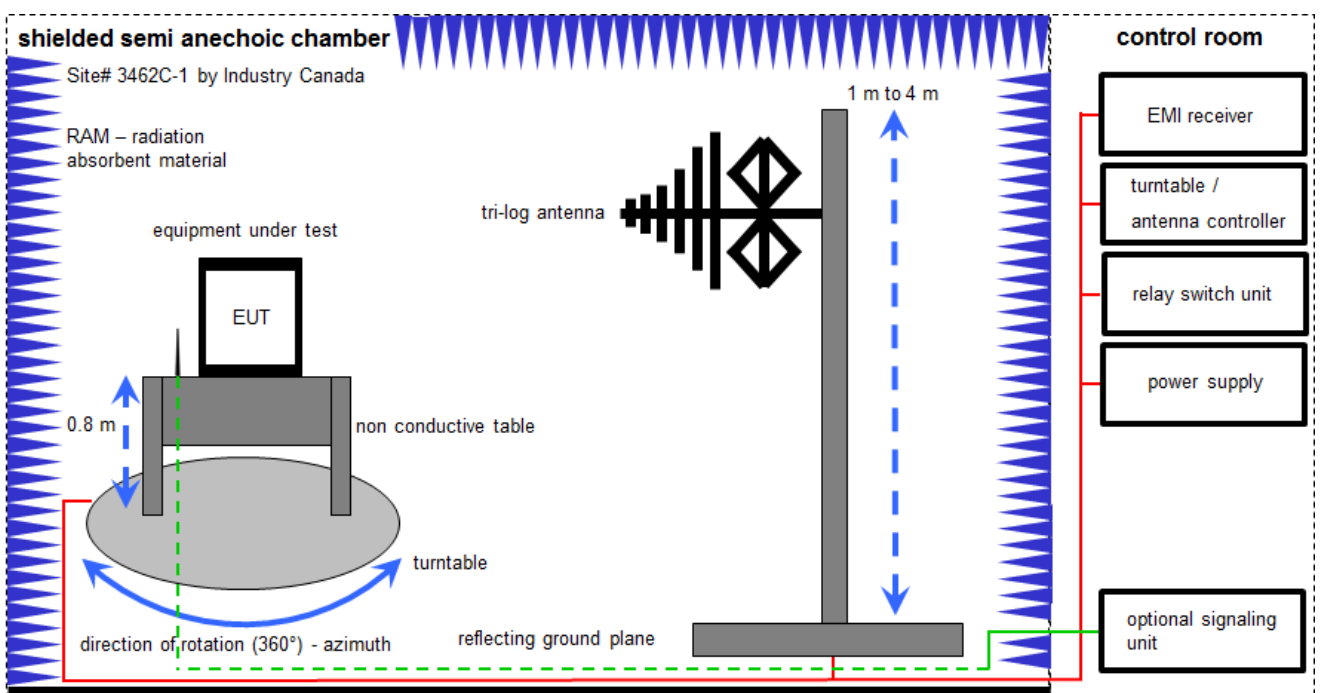

Measurement distance: tri-log antenna 10 meter

$$FS = UR + CL + AF$$

(FS-field strength; UR-voltage at the receiver; CL-loss of the cable; AF-antenna factor)

Example calculation:

$$FS [dB\mu V/m] = 12.35 [dB\mu V/m] + 1.90 [dB] + 16.80 [dB/m] = 31.05 [dB\mu V/m] (35.69 \mu V/m)$$

Equipment table:

No.	Lab / Item	Equipment	Type	Manufacturer	Serial No.	INV. No.	Kind of Calibration	Last Calibration	Next Calibration
1	n. a.	Switch-Unit	3488A	HP	2719A14505	300000368	ev	-/-	-/-
2	n. a.	DC power supply, 60Vdc, 50A, 1200 W	6032A	HP	2920A04466	300000580	ne	-/-	-/-
3	n. a.	Meßkabine 1	HF-Absorberhalle	MWB AG 300023		300000551	ne	-/-	-/-
4	n. a.	EMI Test Receiver	ESCI 3	R&S	101240	300003312	k	14.12.2022	31.12.2023
5	n. a.	Antenna Tower	Model 2175	ETS-Lindgren	64762	300003745	izw	-/-	-/-
6	n. a.	Positioning Controller	Model 2090	ETS-Lindgren	64672	300003746	izw	-/-	-/-
7	n. a.	Turntable Interface-Box	Model 105637	ETS-Lindgren	44583	300003747	izw	-/-	-/-
8	n. a.	TRILOG Broadband Test-Antenna 30 MHz - 3 GHz	VULB9163	Schwarzbeck Mess - Elektronik	318	300003696	vKI!	30.09.2019	29.09.2023
9	n. a.	Switch-Unit	3488A	HP	2719A14505	300000368	ev	-/-	-/-
10	n. a.	EMI Test Receiver	ESR3	Rohde & Schwarz	102587	300005771	k	20.05.2022	31.05.2023

7.2 Shielded fully anechoic chamber

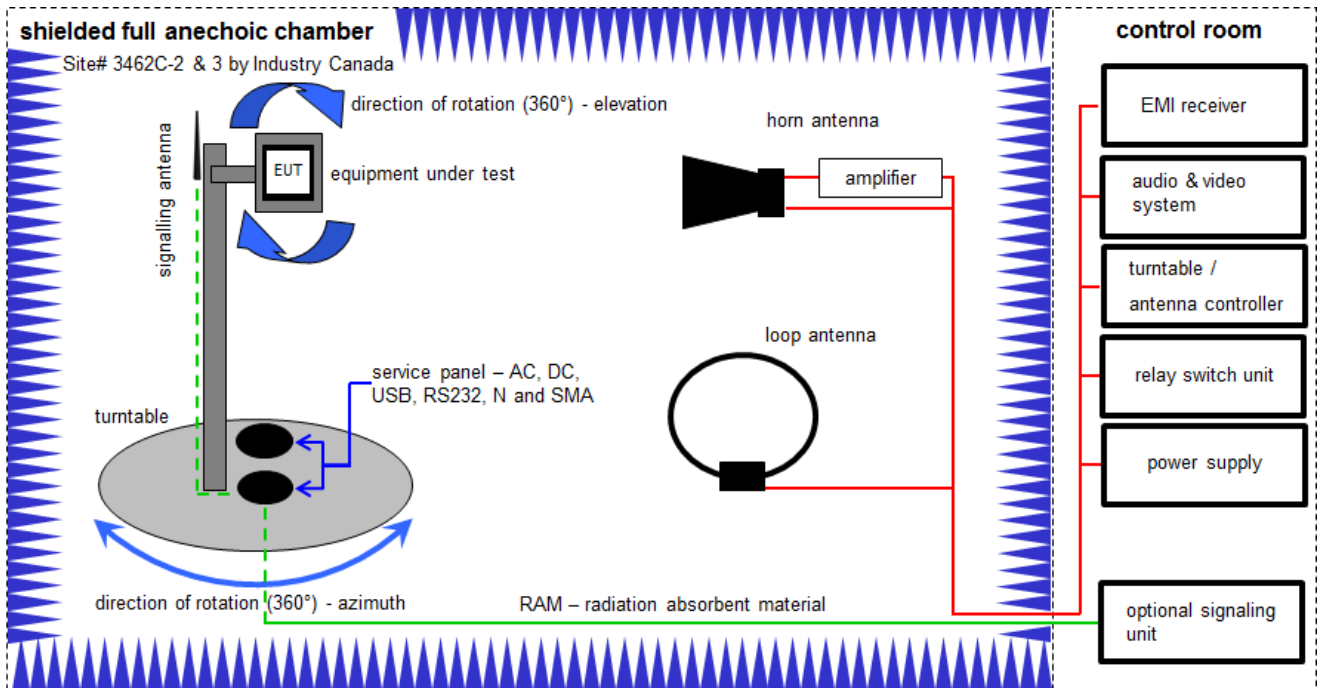

Measurement distance: horn antenna 3 meter; loop antenna 3 meter / 1 meter

$$FS = UR + CA + AF$$

(FS-field strength; UR-voltage at the receiver; CA-loss of the signal path; AF-antenna factor)

Example calculation:

$$FS \text{ [dB}\mu\text{V/m]} = 40.0 \text{ [dB}\mu\text{V/m]} + (-35.8) \text{ [dB]} + 32.9 \text{ [dB/m]} = 37.1 \text{ [dB}\mu\text{V/m]} \text{ (71.61 } \mu\text{V/m)}$$

Equipment table:

No.	Lab / Item	Equipment	Type	Manufacturer	Serial No.	INV. No.	Kind of Calibration	Last Calibration	Next Calibration
1	n. a.	DC power supply, 60Vdc, 50A, 1200 W	6032A	HP	2818A03450	300001040	vKI!	09.12.2020	08.12.2023
2	n. a.	Active Loop Antenna 9 kHz to 30 MHz	6502	EMCO	2210	300001015	vKI!	01.07.2021	31.07.2023
3	n. a.	Anechoic chamber	FAC 3/5m	MWB / TDK	87400/02	300000996	ev	-/-	-/-
4	n. a.	TRILOG Broadband Test-Antenna 30 MHz - 3 GHz	VULB9163	Schwarzbeck Mess - Elektronik	318	300003696	vKI!	30.09.2021	29.09.2023
5	n. a.	Double-Ridged Waveguide Horn Antenna 1-18.0GHz	3115	EMCO	9709-5289	300000213	vKI!	26.07.2022	25.07.2024
6	n. a.	Switch / Control Unit	3488A	HP	*	300000199	ne	-/-	-/-
7	n. a.	Variable isolating transformer	MPL IEC625 Bus Variable isolating transformer	Erfi	91350	300001155	ne	-/-	-/-
8	n. a.	EMI Test Receiver 20Hz- 26,5GHz	ESU26	R&S	100037	300003555	k	07.12.2022	31.12.2023
9	n. a.	Highpass Filter	WHKX7.0/18G-8SS	Wainwright	19	300003790	ne	-/-	-/-
10	n. a.	Broadband Amplifier 0.5-18 GHz	CBLU5184540	CERNEX	22049	300004481	ev	-/-	-/-
11	n. a.	Broadband Amplifier 5-13 GHz	CBLU5135235	CERNEX	22010	300004491	ev	-/-	-/-
12	n. a.	4U RF Switch Platform	L4491A	Agilent Technologies	MY50000037	300004509	ne	-/-	-/-
13	n. a.	NEXIO EMV-Software	BAT EMC V3.16.0.49	EMCO		300004682	ne	-/-	-/-
14	n. a.	PC	ExOne	F+W		300004703	ne	-/-	-/-
15	n. a.	RF-Amplifier	AMF-6F06001800-30-10P-R	NARDA-MITEQ Inc	2011572	300005241	ev	-/-	-/-

7.3 Radiated measurements > 18 GHz

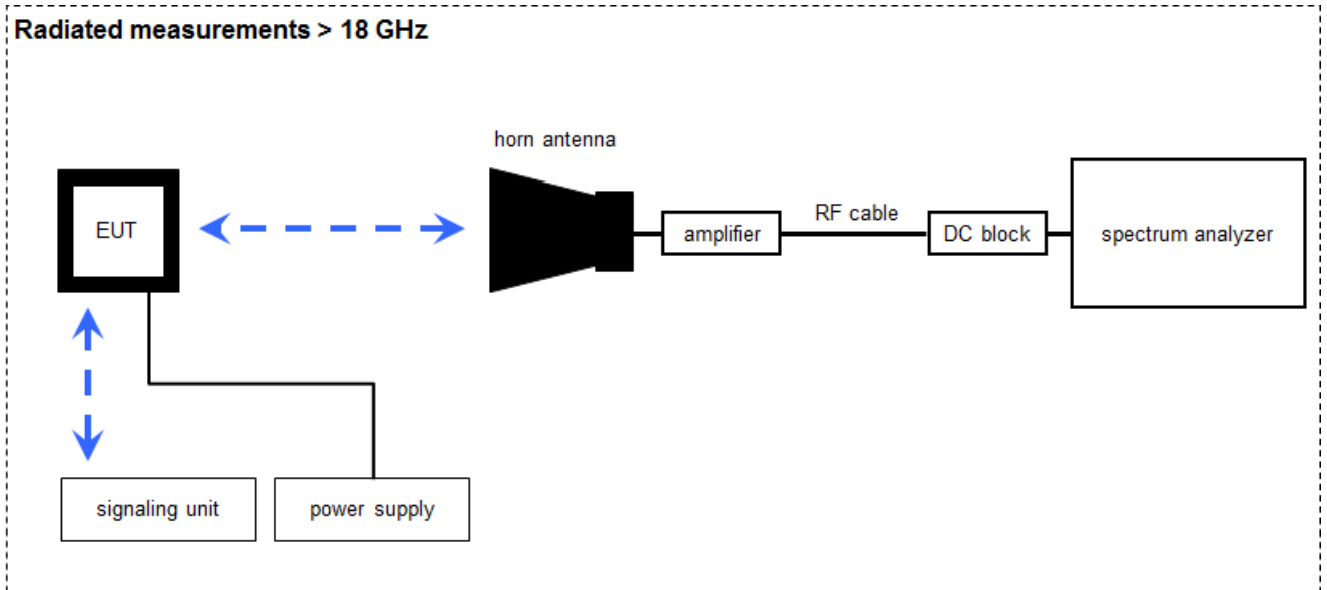

7.4 Radiated measurements > 50/85 GHz

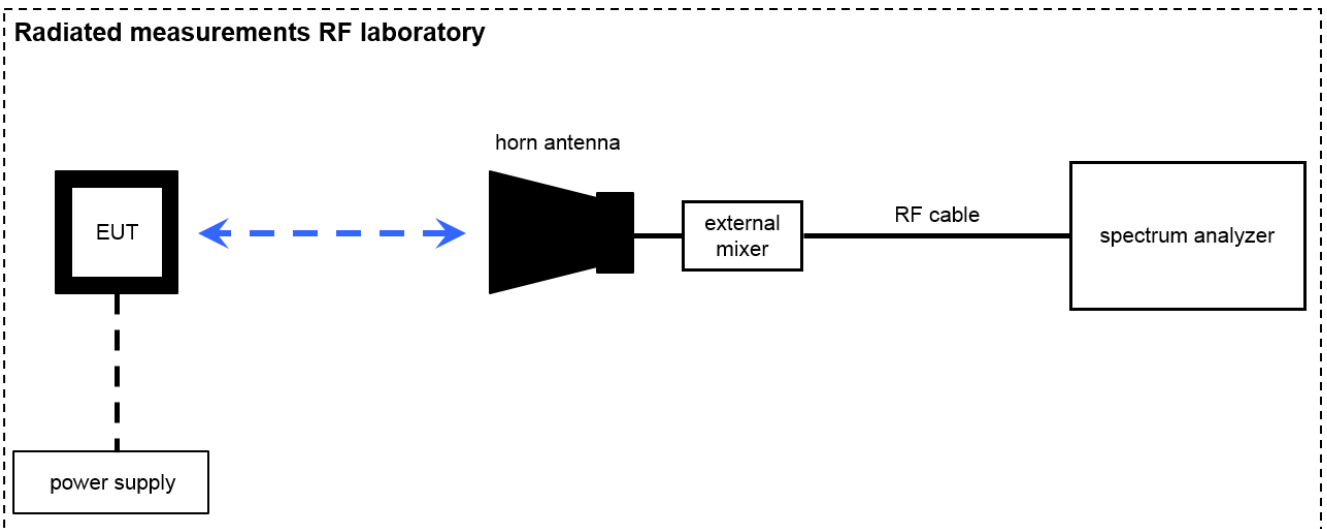

$$OP = AV + D - G$$

(OP-rad. output power; AV-analyzer value; D-free field attenuation of measurement distance; G-antenna gain)

Example calculation:

$$OP [dBm] = -54.0 [dBm] + 64.0 [dB] - 20.0 [dBi] = -10 [dBm] (100 \mu W)$$

Note: conversion loss of mixer is already included in analyzer value.

Equipment table:

No.	Lab / Item	Equipment	Type	Manufacturer	Serial No.	INV. No.	Kind of Calibration	Last Calibration	Next Calibration
1	n.a.	Horn Antenna 18,0-40,0 GHz	LHAF180	Microw.Devel	39180-103-021	300001747	vKI!	17.01.2022	31.01.2024
2	n.a.	Std. Gain Horn Antenna 18.0-26.5 GHz	638	Narda		300000486	vKI!	17.01.2022	31.01.2024
3	n.a.	Std. Gain Horn Antenna 26.5-40.0 GHz	V637	Narda	82-16	300000510	vKI!	17.01.2022	31.01.2024
4	n.a.	Std. Gain Horn Antenna 40-60 GHz	2424-20	Flann	76	400001981	ne	-/-	-/-
5	n.a.	Std. Gain Horn Antenna 49.9-75.8 GHz	2524-20	Flann	*	300001983	ne	-/-	-/-
6	n.a.	Std. Gain Horn Antenna 60-90 GHz	COR 60_90	Thomson CSF		300000814	ev	-/-	-/-
7	n.a.	Std. Gain Horn Antenna 73.8-112 GHz	2724-20	Flann	*	300001988	ne	-/-	-/-
8	n.a.	Std. Gain Horn Antenna 92.3-140 GHz	2824-20	Flann		300001993	ne	-/-	-/-
9	n.a.	Std. Gain Horn Antenna 114-173 GHz	2924-20	Flann	*	300001999	ne	-/-	-/-
10	n.a.	Std. Gain Horn Antenna 145-220 GHz	3024-20	Flann	*	300002000	ne	-/-	-/-
11	n.a.	Std. Gain Horn Antenna 217-330 GHz	32240-20	Flann	233278	300004960	ne	-/-	-/-
12	n.a.	Broadband LNA 18-50 GHz	CBL18503070PN	CERNEX	25240	300004948	ev	09.03.2022	08.03.2024
13	n.a.	Harmonic Mixer 3-Port, 50-75 GHz	FS-Z75	Rohde & Schwarz	101578	300005788	k	07.07.2022	31.07.2023
14	n.a.	Harmonic Mixer 3-Port, 60-90 GHz	FS-Z90	R&S	101555	300004691	k	21.07.2022	31.07.2023
15	n.a.	Harmonic Mixer 3-Port, 75-110 GHz	FS-Z110	R&S	101411	300004959	k	07.07.2022	31.07.2023
16	n.a.	Harmonic Mixer 3-port, 90-140 GHz	FS-Z140	Rohde & Schwarz	101119	300005581	k	20.07.2022	31.07.2023
17	n.a.	Harmonic Mixer 3-Port, 110-170 GHz	FS-Z170	Radiometer Physics GmbH	100014	300004156	k	01.07.2022	31.07.2023
18	n.a.	Harmonic Mixer 3-Port, 140-220 GHz	SAM-220	Radiometer Physics GmbH	200001	300004157	k	21.07.2022	31.07.2023
19	n.a.	Harmonic Mixer 3-Port, 220-325 GHz	SAM-325	Radiometer Physics GmbH	100002	300004158	k	25.07.2022	31.07.2023
20	n.a.	Spectrum Analyzer 2 Hz - 85 GHz	FSW85	R&S	101333	300005568	k	11.07.2022	31.07.2023
21	n.a.	Power Supply	E3632A	Agilent Technologies	MY40001320	400000396	ev	-/-	-/-
22	n.a.	Temperature Test Chamber	VT4002	Heraeus Voetsch	521/83761	300002326	ev	12.05.2022	31.05.2024

8 Sequence of testing

8.1 Sequence of testing radiated spurious 9 kHz to 30 MHz

Setup

- The equipment is set up to simulate normal operation mode as described in the user manual or defined by the manufacturer.
- If the EUT is a tabletop system, it is placed on a table with 0.8 m height.
- If the EUT is a floor standing device, it is placed directly on the turn table.
- Auxiliary equipment and cables are positioned to simulate normal operation conditions as described in ANSI C 63.4.
- The AC power port of the EUT (if available) is connected to a power outlet below the turntable.
- Measurement distance is 3 m (see ANSI C 63.4) – see test details.
- EUT is set into operation.

Premeasurement*

- The turntable rotates from 0° to 315° using 45° steps.
- The antenna height is 1 m.
- At each turntable position the analyzer sweeps with positive-peak detector to find the maximum of all emissions.

Final measurement

- Identified emissions during the pre-measurement are maximized by the software by rotating the turntable from 0° to 360°.
- Loop antenna is rotated about its vertical axis for maximum response at each azimuth about the EUT. (For certain applications, the loop antenna plane may also need to be positioned horizontally at the specified distance from the EUT)
- The final measurement is done in the position (turntable and elevation) causing the highest emissions with quasi-peak (as described in ANSI C 63.4).
- Final levels, frequency, measuring time, bandwidth, turntable position, correction factor, margin to the limit and limit will be recorded. A plot with the graph of the premeasurement and the limit is stored.

*Note: The sequence will be repeated three times with different EUT orientations.

8.2 Sequence of testing radiated spurious 30 MHz to 1 GHz

Setup

- The equipment is set up to simulate normal operation mode as described in the user manual or defined by the manufacturer.
- If the EUT is a tabletop system, a table with 0.8 m height is used, which is placed on the ground plane.
- If the EUT is a floor standing device, it is placed on the ground plane with insulation between both.
- Auxiliary equipment and cables are positioned to simulate normal operation conditions as described in ANSI C 63.4.
- The AC power port of the EUT (if available) is connected to a power outlet below the turntable.
- Measurement distance is 10 m or 3 m (see ANSI C 63.4) – see test details.
- EUT is set into operation.

Premeasurement

- The turntable rotates from 0° to 315° using 45° steps.
- The antenna is polarized vertical and horizontal.
- The antenna height changes from 1 m to 3 m.
- At each turntable position, antenna polarization and height the analyzer sweeps three times in peak to find the maximum of all emissions.

Final measurement

- The final measurement is performed for at least six highest peaks according to the requirements of the ANSI C63.4.
- Based on antenna and turntable positions at which the peak values are measured the software maximize the peaks by changing turntable position $\pm 45^\circ$ and antenna height between 1 and 4 m.
- The final measurement is done with quasi-peak detector (as described in ANSI C 63.4).
- Final levels, frequency, measuring time, bandwidth, antenna height, antenna polarization, turntable angle, correction factor, margin to the limit and limit are recorded. A plot with the graph of the premeasurement with marked maximum final results and the limit is stored.

8.3 Sequence of testing radiated spurious 1 GHz to 18 GHz

Setup

- The equipment is set up to simulate normal operation mode as described in the user manual or defined by the manufacturer.
- If the EUT is a tabletop system, a 2-axis positioner with 1.5 m height is used.
- If the EUT is a floor standing device, it is placed directly on the turn table.
- Auxiliary equipment and cables are positioned to simulate normal operation conditions as described in ANSI C 63.4.
- The AC power port of the EUT (if available) is connected to a power outlet below the turntable.
- Measurement distance is 3 m (see ANSI C 63.4) – see test details.
- EUT is set into operation.

Premeasurement

- The turntable rotates from 0° to 315° using 45° steps.
- The antenna is polarized vertical and horizontal.
- The antenna height is 1.5 m.
- At each turntable position and antenna polarization the analyzer sweeps with positive peak detector to find the maximum of all emissions.

Final measurement

- The final measurement is performed for at least six highest peaks according to the requirements of the ANSI C63.4.
- Based on antenna and turntable positions at which the peak values are measured the software maximizes the peaks by rotating the turntable from 0° to 360°. This measurement is repeated for different EUT-table positions (0° to 150° in 30°-steps) and for both antenna polarizations.
- The final measurement is done in the position (turntable, EUT-table and antenna polarization) causing the highest emissions with Peak and RMS detector (as described in ANSI C 63.4).
- Final levels, frequency, measuring time, bandwidth, turntable position, EUT-table position, antenna polarization, correction factor, margin to the limit and limit are recorded. A plot with the graph of the premeasurement with marked maximum final results and the limit is stored.

8.4 Sequence of testing radiated spurious above 18 GHz

Setup

- The equipment is set up to simulate normal operation mode as described in the user manual or defined by the manufacturer.
- Auxiliary equipment and cables are positioned to simulate normal operation conditions as described in ANSI C 63.4.
- The AC power port of the EUT (if available) is connected to a power outlet.
- The measurement distance is as appropriate (e.g. 0.5 m).
- The EUT is set into operation.

Premeasurement

- The test antenna is handheld and moved carefully over the EUT to cover the EUT's whole sphere and different polarizations of the antenna.

Final measurement

- The final measurement is performed at the position and antenna orientation causing the highest emissions with Peak and RMS detector (as described in ANSI C 63.4).
- Final levels, frequency, measuring time, bandwidth, correction factor, margin to the limit and limit are recorded. A plot with the graph of the premeasurement and the limit is stored.

8.5 Sequence of testing radiated spurious above 50/85 GHz with external mixers

Setup

- The equipment is set up to simulate normal operation mode as described in the user manual or defined by the manufacturer.
- Auxiliary equipment and cables are positioned to simulate normal operation conditions as described in ANSI C 63.4.
- The AC power port of the EUT (if available) is connected to a power outlet.
- The measurement distance is as appropriate for far field (e.g. 0.25 m).
- The EUT is set into operation.

Premeasurement

- The test antenna with external mixer is handheld and moved carefully over the EUT to cover the EUT's whole sphere and different polarizations of the antenna.
- Caution is taken to reduce the possible overloading of the external mixer.

Final measurement

- The final measurement is performed at the position and antenna orientation causing the highest emissions with Peak and RMS detector (as described in ANSI C 63.4).
- As external mixers may generate false images care is taken to ensure that any emission measured by the spectrum analyzer does indeed originate in the EUT. Signal identification feature of spectrum analyzer is used to eliminate false mixer images (i.e., it is not the fundamental emission or a harmonic falling precisely at the measured frequency).
- Final levels, frequency, measuring time, bandwidth, correction factor, margin to the limit and limit are recorded. A plot with the graph of the premeasurement and the limit is stored.

9 Measurement uncertainty

Test case	Uncertainty
Equivalent isotropically radiated power (e.i.r.p.)	Conducted value ± 1 dB Radiated value ± 3 dB
Permitted range of operating frequencies	± 100 kHz
Conducted unwanted emissions in the spurious domain (up to 40	± 1 dB
Radiated unwanted emissions in the spurious domain (up to 40	± 3 dB
Conducted unwanted emissions in the spurious domain (40 to 50	± 4 dB
Radiated unwanted emissions in the spurious domain (40 to 50	± 4 dB
Conducted unwanted emissions in the spurious domain (50 to	± 5 dB
Radiated unwanted emissions in the spurious domain (50 to 300	± 5 dB
DC and low frequency voltages	± 3 %
Temperature	± 1 °C
Humidity	± 3 %

10 Far field consideration for measurements above 18 GHz

Far field distance calculation:

$$D_{ff} = 2 \times D^2 / \lambda$$

with

D_{ff} Far field distance
 D Antenna dimension
 λ wavelength

Spurious emission measurements:

Antenna frequency Range in GHz	Highest measured frequency in GHz	D in cm	λ in cm	D_{ff} in cm
18-26	26	3.4	1.15	20.04
26-40	40	2.2	0.75	12.91
40-50	50	2.77	0.60	25.58
50-75	75	1.85	0.40	17.11
75-110	110	1.24	0.27	11.28
90-140	140	1.02	0.22	9.72
110-170	170	0.85	0.18	8.19
140-220	220	0.68	0.14	6.78
220-325	325	0.43	0.09	4.01
325-500	500	0.26	0.06	2.22

11 Summary of measurement results

11.1 Summary

<input checked="" type="checkbox"/>	No deviations from the technical specifications were ascertained
<input type="checkbox"/>	There were deviations from the technical specifications ascertained
<input type="checkbox"/>	This test report is only a partial test report. The content and verdict of the performed test cases are listed below.

TC Identifier	Description	Verdict	Date	Remark
RF-Testing	47 CFR Part 95 Subpart M	see below	2023-04-11	-/-

Test specification clause	Test case	Temperature conditions	Power source voltages	Pass	Fail	NA	NP	Remark
§2.1046 §95.3367 (a) / (b)	Radiated power	Nominal	Nominal	<input checked="" type="checkbox"/>	<input type="checkbox"/>	<input type="checkbox"/>	<input type="checkbox"/>	complies
§2.1047	Modulation characteristics	-/-	-/-	<input checked="" type="checkbox"/>	<input type="checkbox"/>	<input type="checkbox"/>	<input type="checkbox"/>	complies
§2.1049	Occupied bandwidth (99% bandwidth)	Nominal	Nominal	<input checked="" type="checkbox"/>	<input type="checkbox"/>	<input type="checkbox"/>	<input type="checkbox"/>	complies
§2.1051	Spurious emissions at antenna terminals	Nominal	Nominal	<input checked="" type="checkbox"/>	<input type="checkbox"/>	<input type="checkbox"/>	<input type="checkbox"/>	See note
§2.1053 §95.3379 (a)(1) §95.3379 (a)(2) §95.3379 (a)(3)	Field strength of emissions (radiated spurious)	Nominal	Nominal	<input checked="" type="checkbox"/>	<input type="checkbox"/>	<input type="checkbox"/>	<input type="checkbox"/>	complies
§2.1055 §95.3379 (b)	Frequency stability	Nominal and Extreme	Nominal and Extreme	<input checked="" type="checkbox"/>	<input type="checkbox"/>	<input type="checkbox"/>	<input type="checkbox"/>	complies

Note: C = Compliant; NC = Not compliant; NA = Not applicable; NP = Not performed

See FCC's Millimeter Wave Test Procedures:

I. A radiated method of measurements in order to demonstrate compliance with the various regulatory requirements has been chosen in consideration of test equipment availability and the limitations of many external harmonic mixers. A conducted method of measurement could be employed if EUT and mixer waveguides both are accessible and of the same type (WG number) and if waveguide sections and transitions can be found. Another potential problem is that the peak power output of devices operating under Sections 15.253 and 15.255 may exceed the +20 dBm input power limit of many commercially available mixers. For these reasons a radiated method is preferred.

12 Measurement results

12.1 Radiated power

Description:

§95.3367:

The fundamental radiated emission limits within the 76-81 GHz band are expressed in terms of Equivalent Isotropically Radiated Power (EIRP) and are as shown below.

Limits:

FCC §95.3367 (a) (b)/ RSS-251 (5.2.2)

Frequency	Limit (eirp)
76.0 - 81.0 GHz	50 dBm (Average)
	55 dBm/MHz (PEAK)

Measurement: Average Power

Measurement parameter	
Detector:	RMS
Sweep time:	120 s
Resolution bandwidth:	1 MHz
Video bandwidth:	3 MHz
Trace-Mode:	Clear Write
Measurement distance:	2 m

Measurement: Peak Power

Measurement parameter	
Detector:	Pos-Peak
Sweep time:	120 s
Resolution bandwidth:	1 MHz
Video bandwidth:	3 MHz
Trace-Mode:	Max Hold
Measurement distance:	2 m

Measurement results:

Modulations / Test conditions		Radiated Peak Power (eirp) [dBm]	Radiated Mean Power (eirp) / Channel power [dBm]
03	$T_{nom} / V_{min-max}$	34.96	26.70
	$T_{min} / V_{min-max}$	35.26	27.20
	$T_{max} / V_{min-max}$	35.05	25.97
09	$T_{nom} / V_{min-max}$	35.70	26.67
	$T_{min} / V_{min-max}$	36.16	27.22
	$T_{max} / V_{min-max}$	34.94	26.02
15	$T_{nom} / V_{min-max}$	36.24	26.69
	$T_{min} / V_{min-max}$	36.79	27.27
	$T_{max} / V_{min-max}$	35.38	25.99
21	$T_{nom} / V_{min-max}$	36.03	26.68
	$T_{min} / V_{min-max}$	36.65	27.29
	$T_{max} / V_{min-max}$	35.31	25.99
27	$T_{nom} / V_{min-max}$	28.41	20.54
	$T_{min} / V_{min-max}$	27.69	19.80
	$T_{max} / V_{min-max}$	29.19	21.14
39	$T_{nom} / V_{min-max}$	29.40	20.55
	$T_{min} / V_{min-max}$	28.14	19.38
	$T_{max} / V_{min-max}$	30.30	21.51
51	$T_{nom} / V_{min-max}$	29.91	20.56
	$T_{min} / V_{min-max}$	28.83	19.39
	$T_{max} / V_{min-max}$	30.42	20.53
63	$T_{nom} / V_{min-max}$	29.67	20.56
	$T_{min} / V_{min-max}$	28.95	19.82
	$T_{max} / V_{min-max}$	30.39	21.10
80	$T_{nom} / V_{min-max}$	28.23	17.71
	$T_{min} / V_{min-max}$	26.22	16.32
	$T_{max} / V_{min-max}$	27.42	17.51

Note: Voltage variation does not affect the radiated signal

Verdict: Compliant

Plot 1: OBW, Mode 03, T_{nom} / $V_{min-max}$

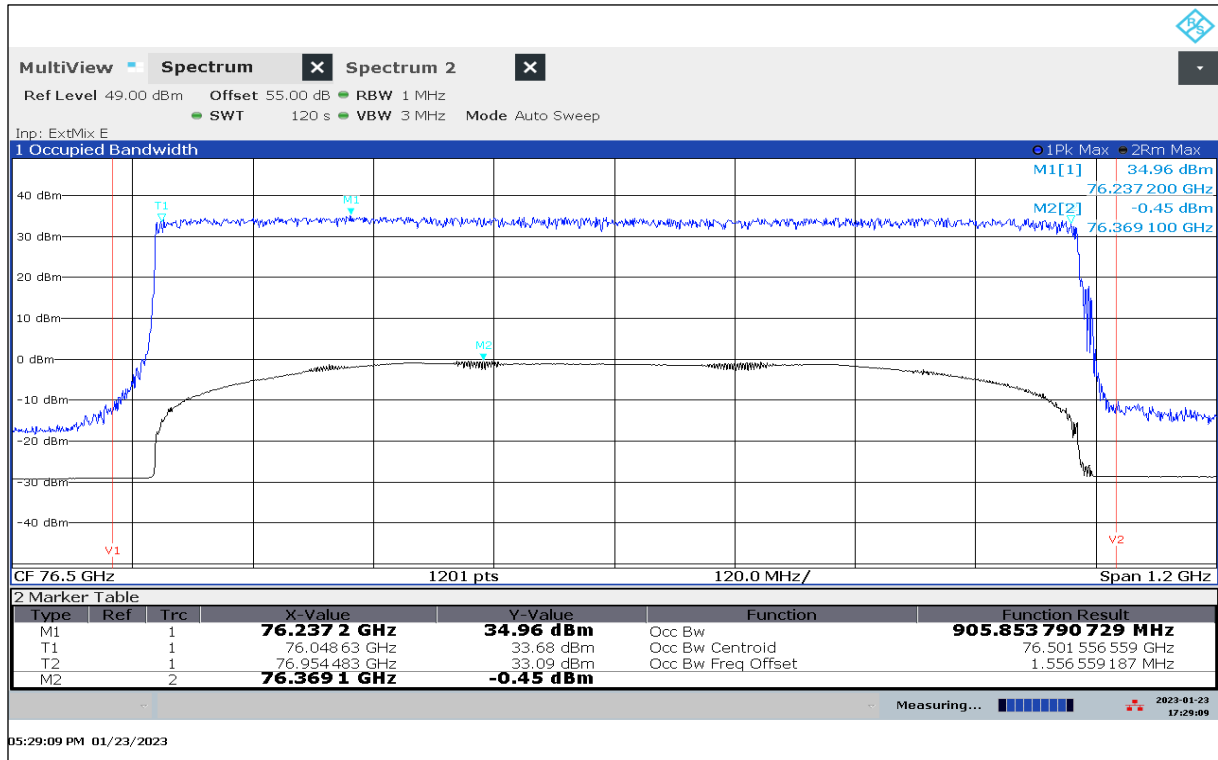

Plot 2: OBW, Mode 03, T_{min} / $V_{min-max}$

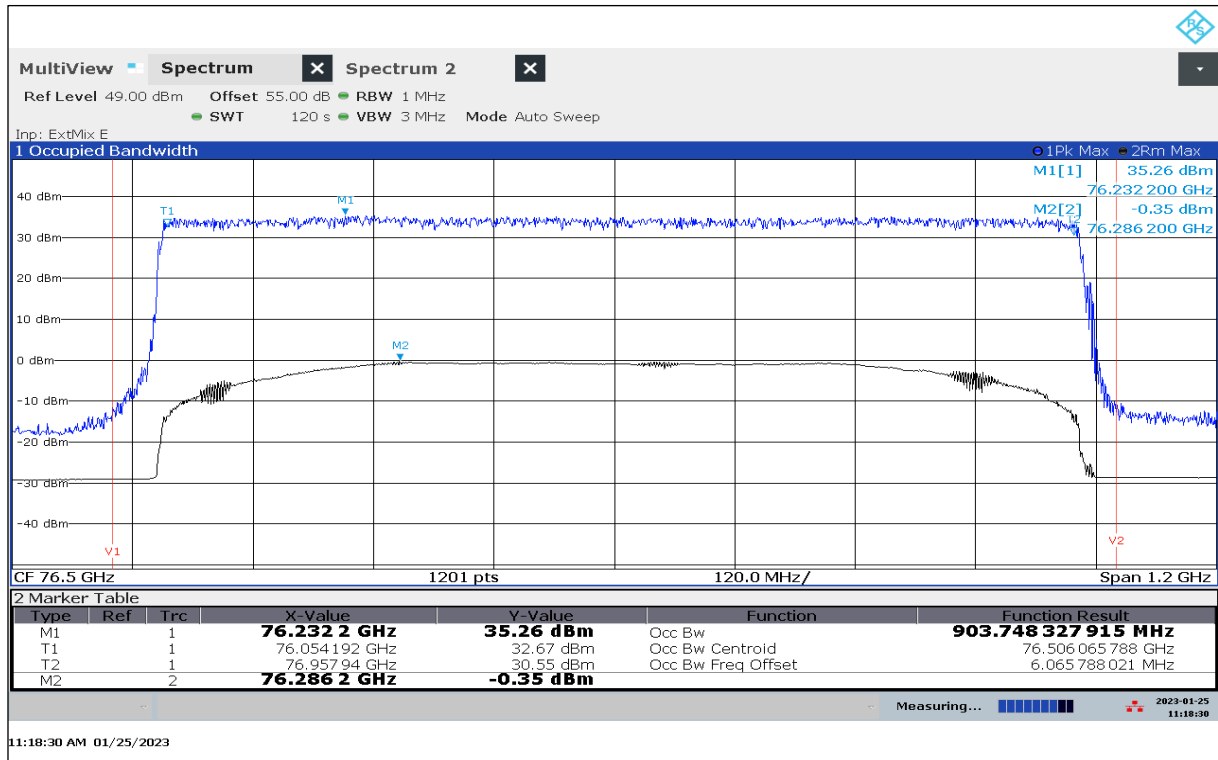

Plot 3: OBW, Mode 03, T_{max} / $V_{min-max}$

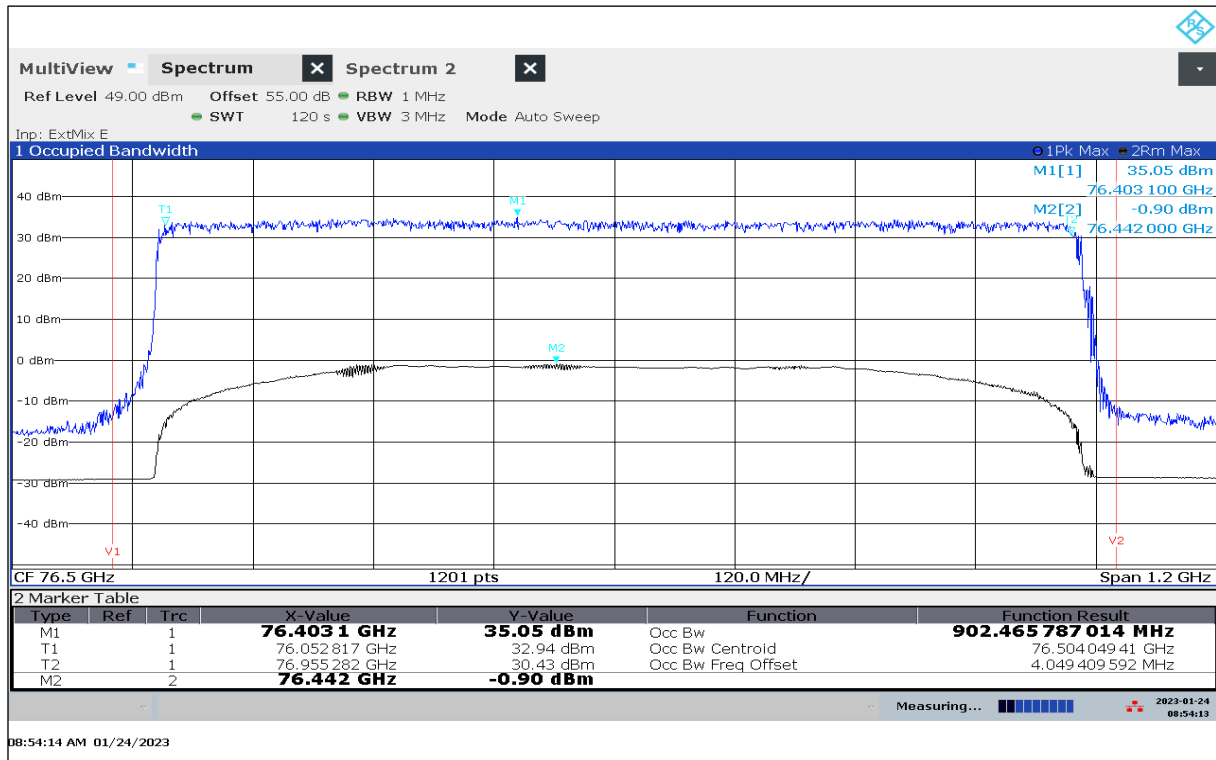

Plot 4: OBW, Mode 09, T_{nom} / $V_{min-max}$

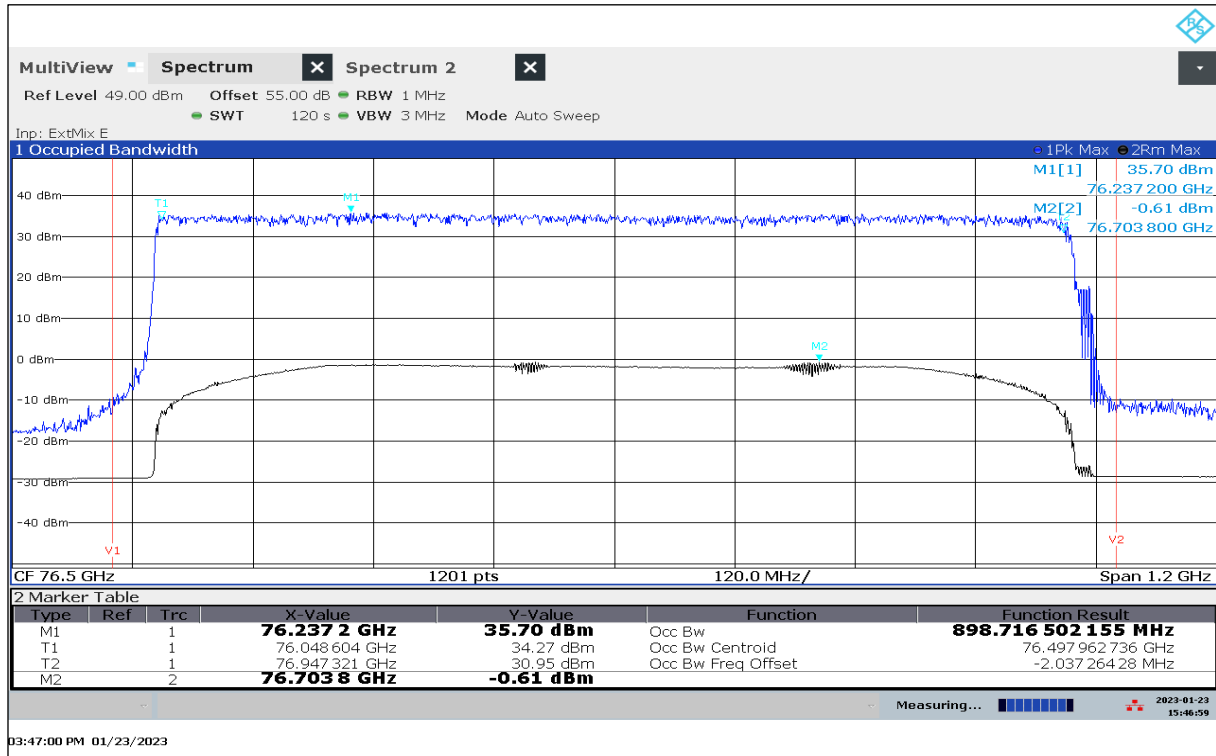

Plot 5: OBW, Mode 09, $T_{min} / V_{min-max}$

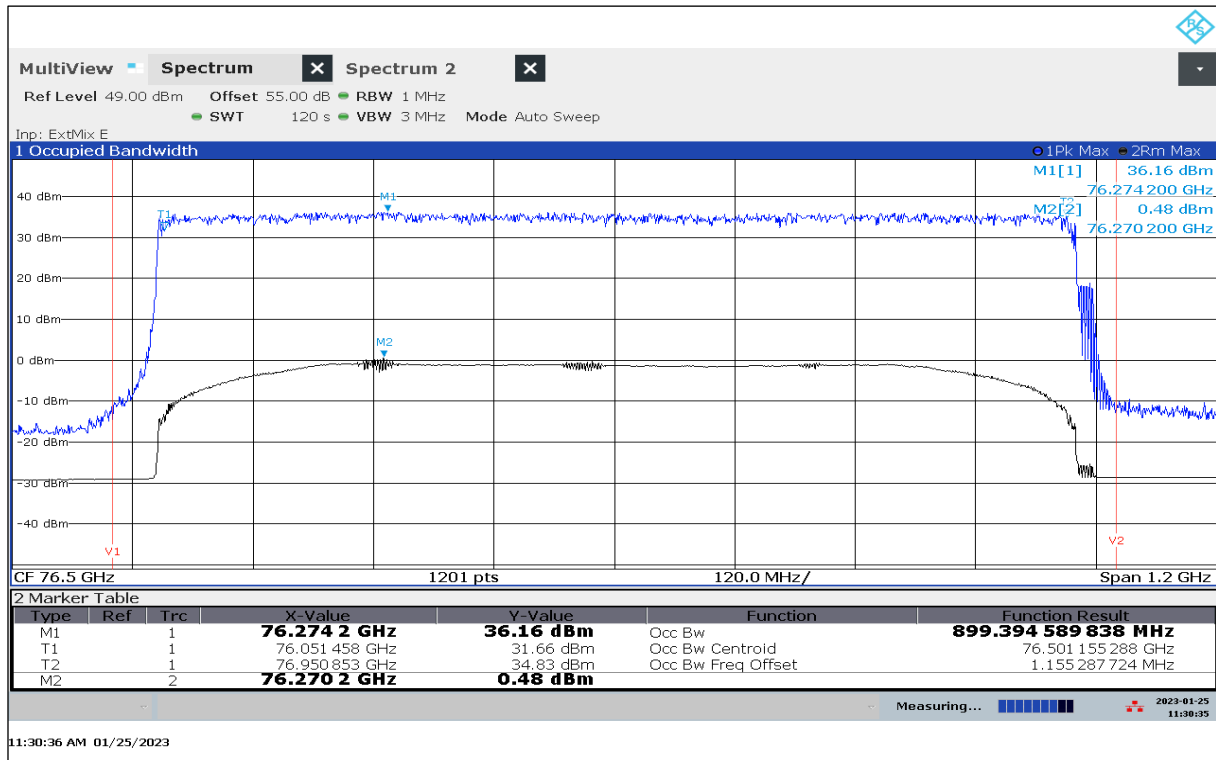

Plot 6: OBW, Mode 09, $T_{max} / V_{min-max}$

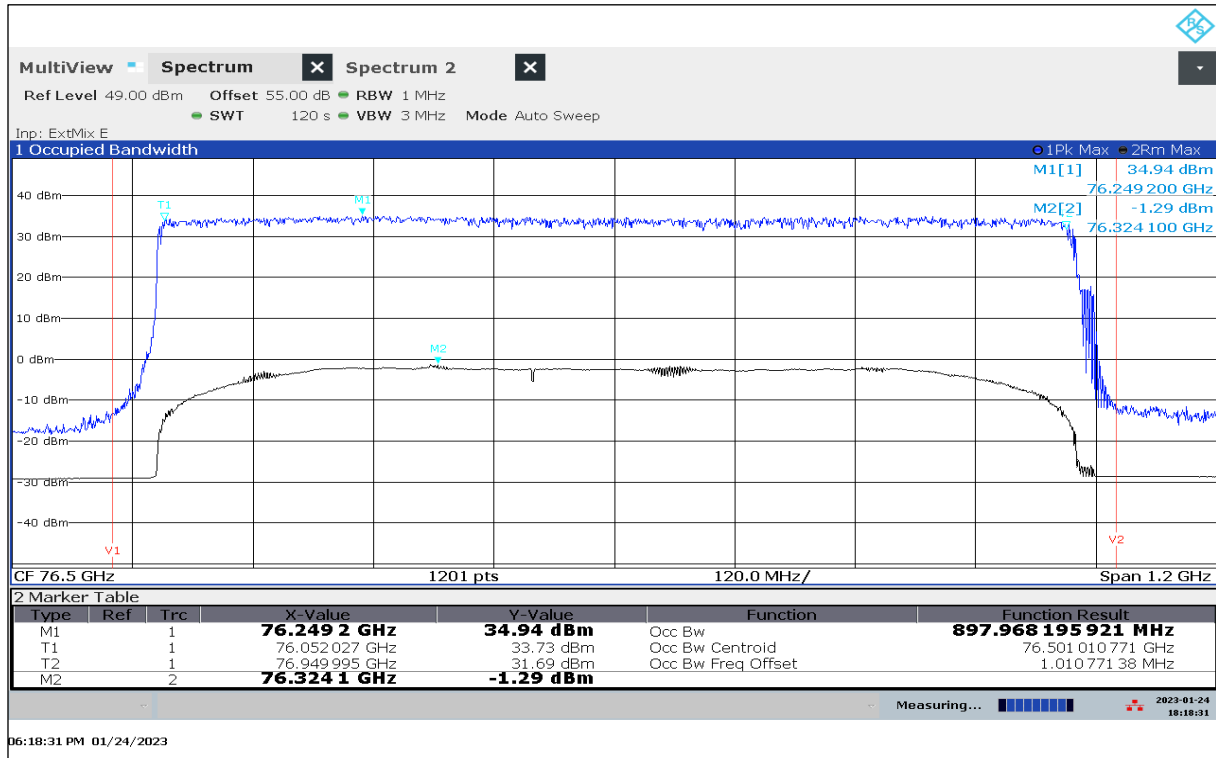

Plot 7: OBW, Mode 15, T_{nom} / $V_{min-max}$

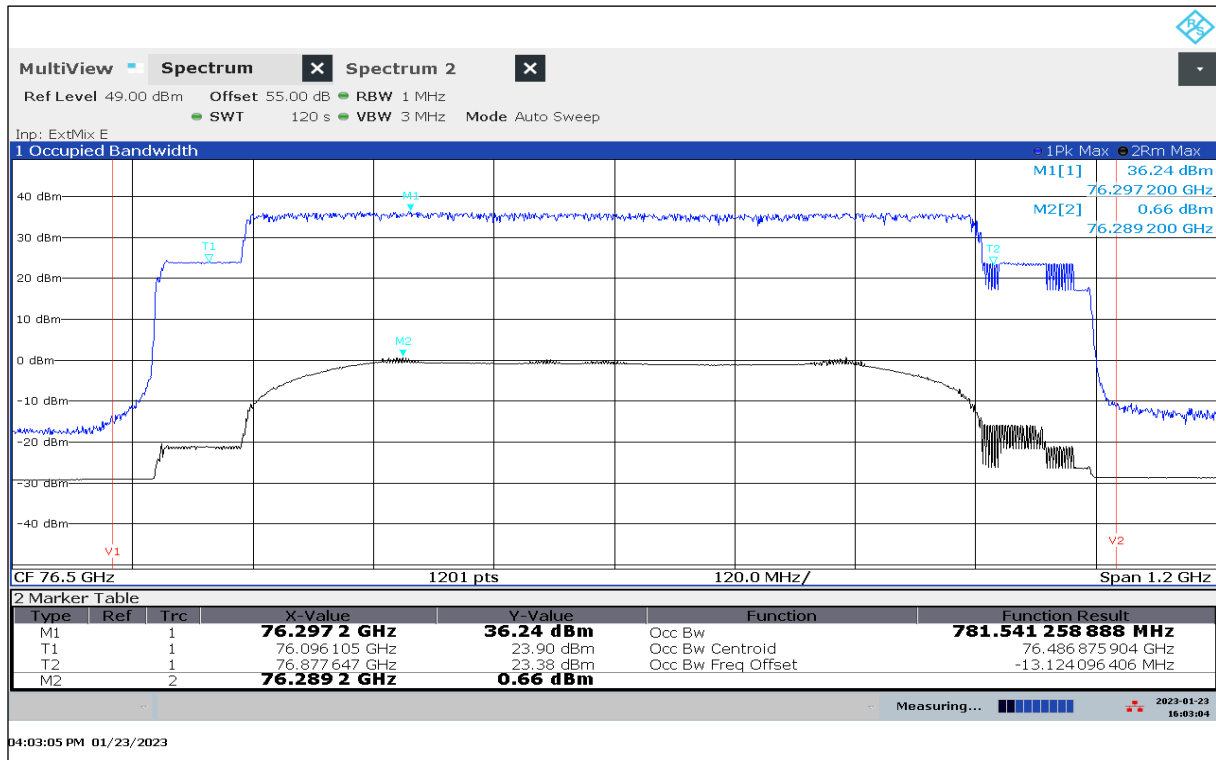

Plot 8: OBW, Mode 15, T_{min} / $V_{min-max}$

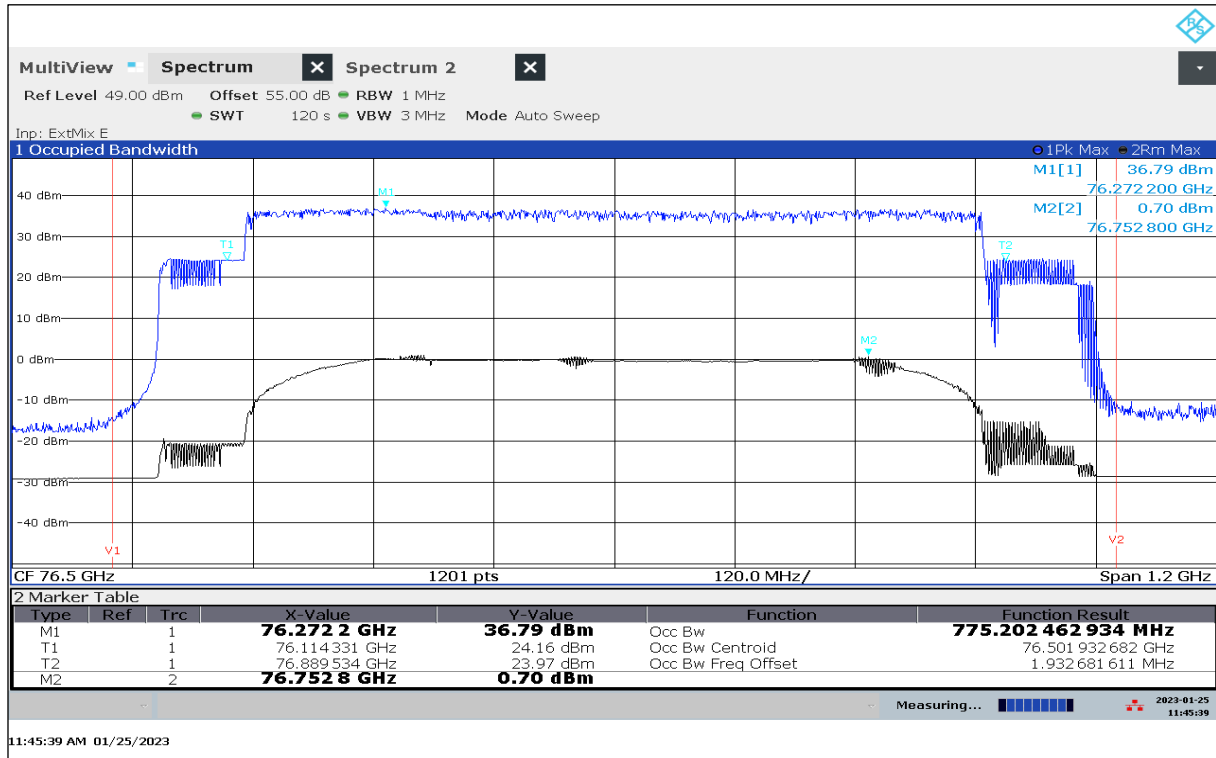

Plot 9: OBW, Mode 15, $T_{max} / V_{min-max}$

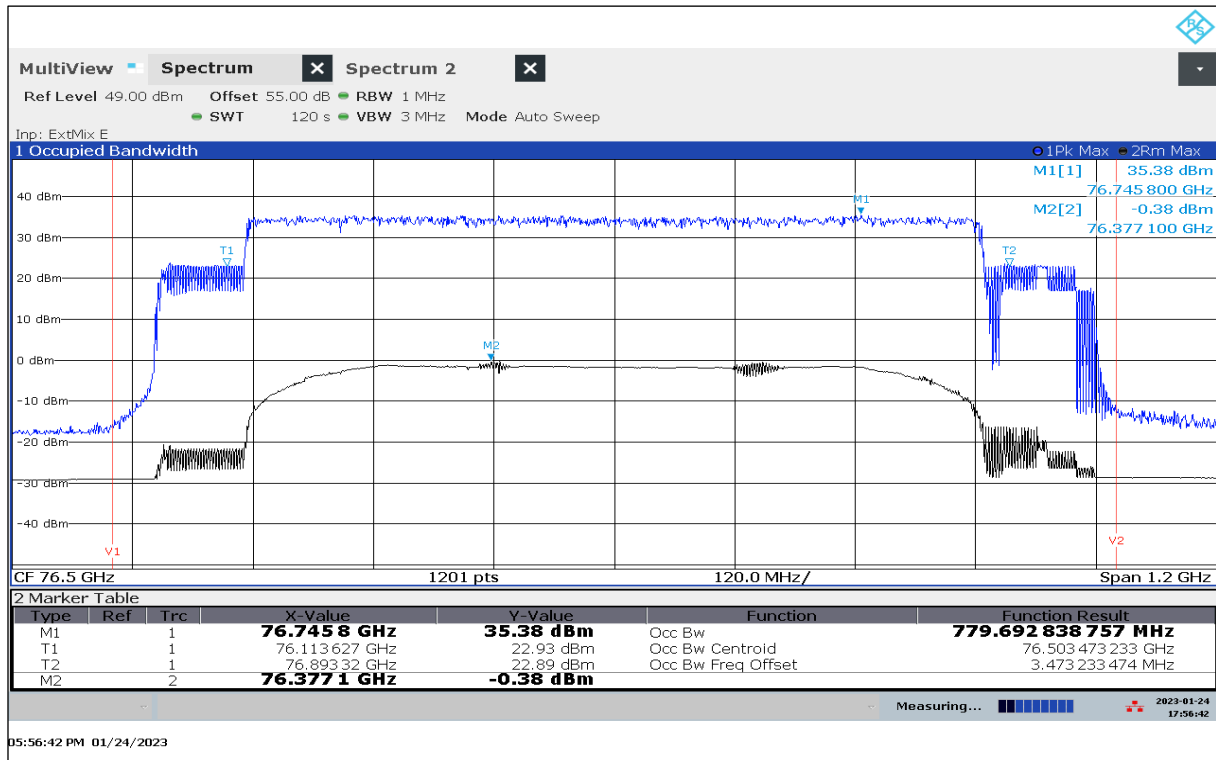

Plot 10: OBW, Mode 21, $T_{nom} / V_{min-max}$

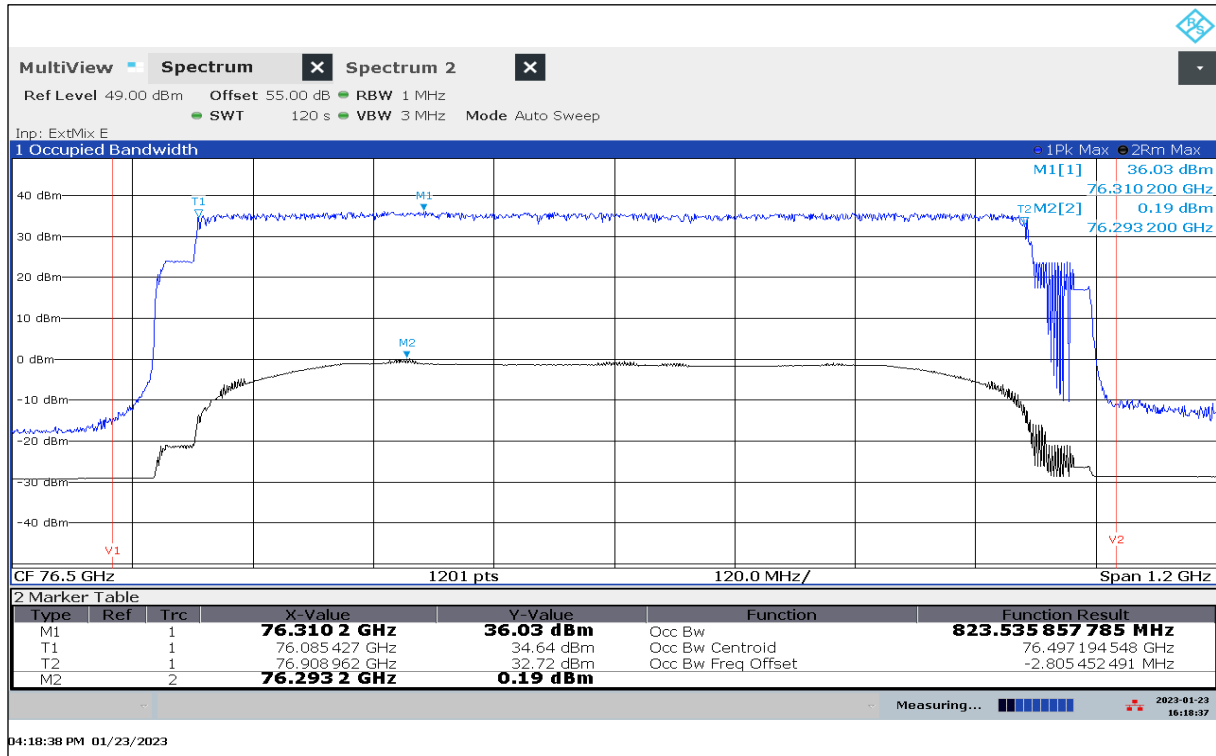

Plot 11: OBW, Mode 21, $T_{min} / V_{min-max}$

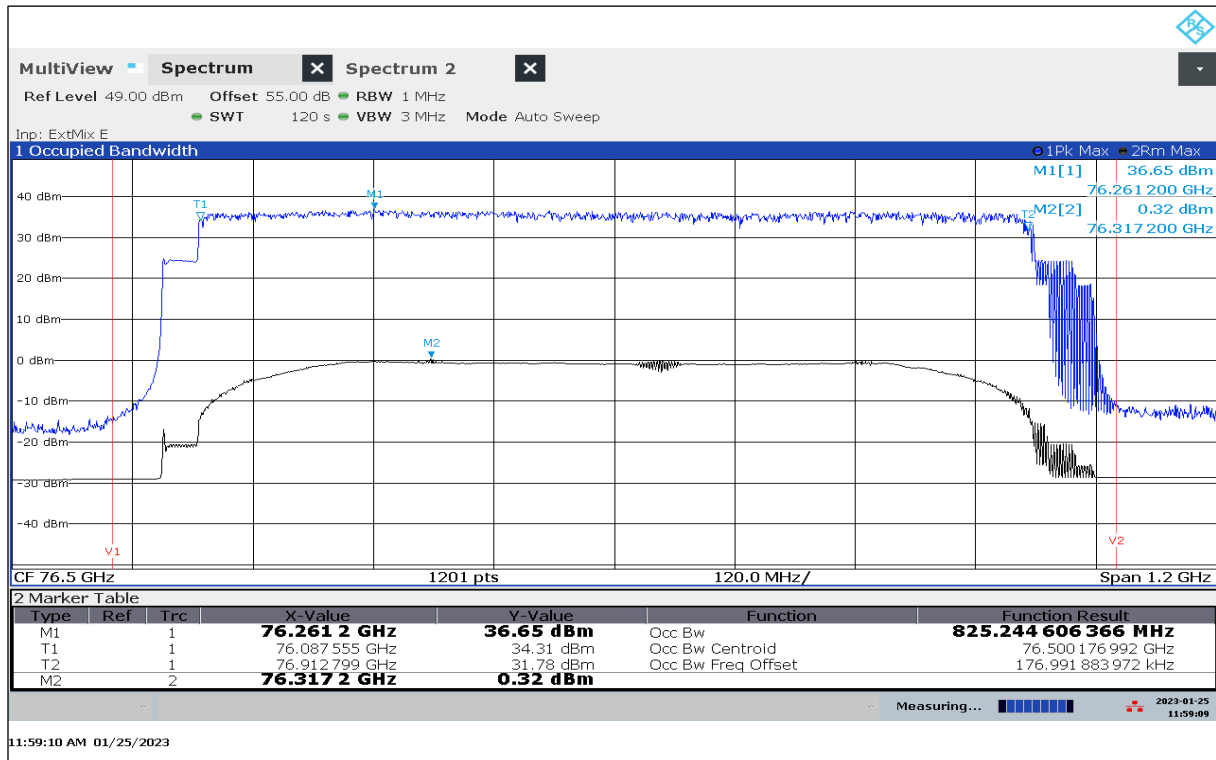

Plot 12: OBW, Mode 21, $T_{max} / V_{min-max}$

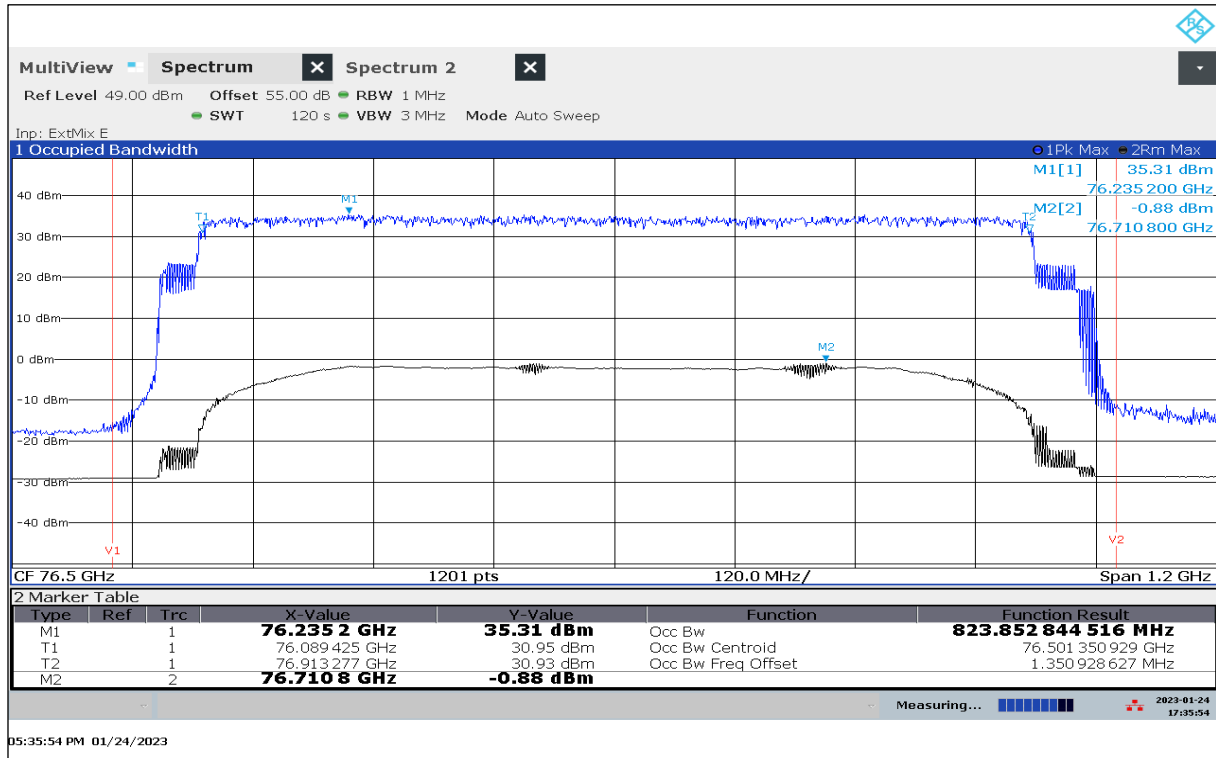

Plot 13: OBW, Mode 27, $T_{nom} / V_{min-max}$

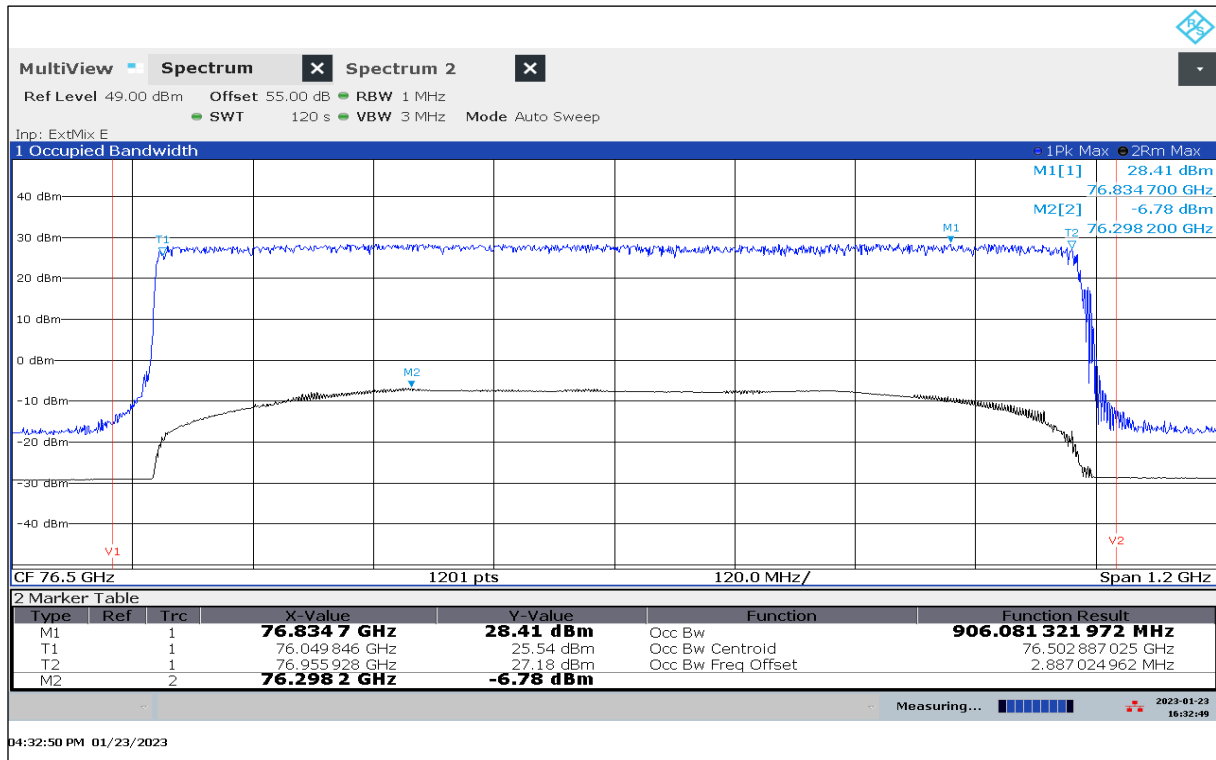

Plot 14: OBW, Mode 27, $T_{min} / V_{min-max}$

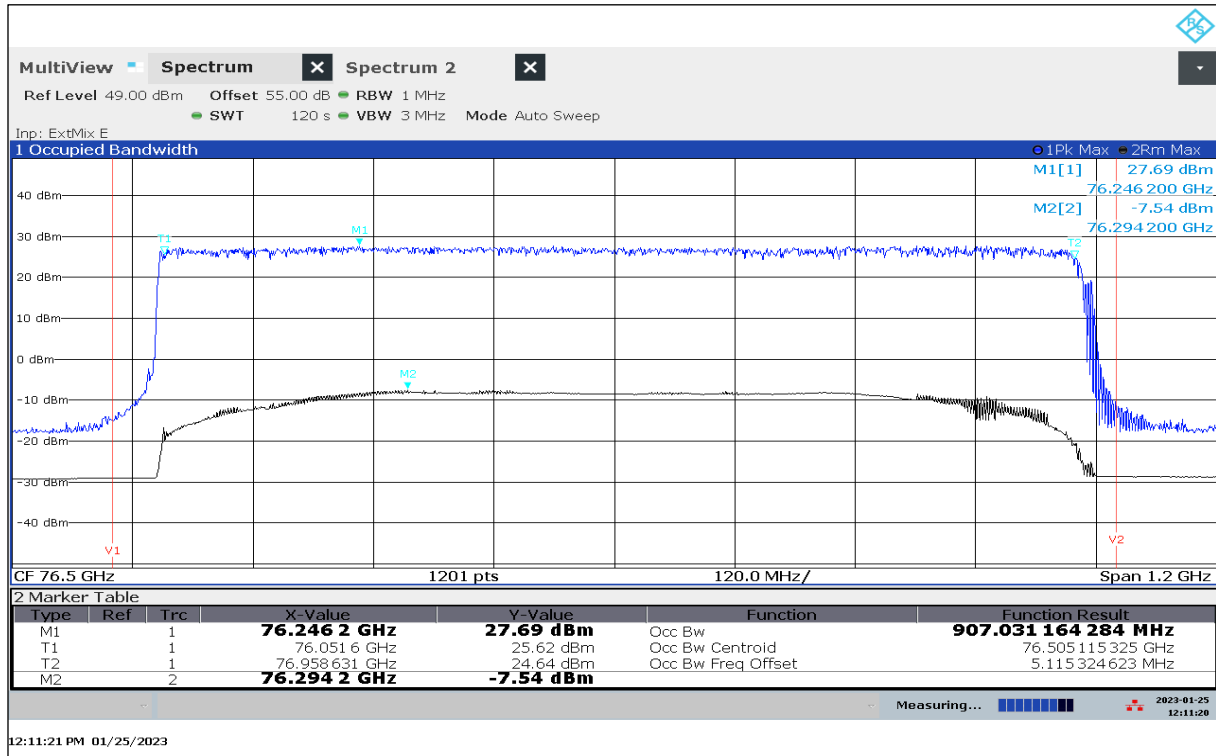

Plot 15: OBW, Mode 27, $T_{max} / V_{min-max}$

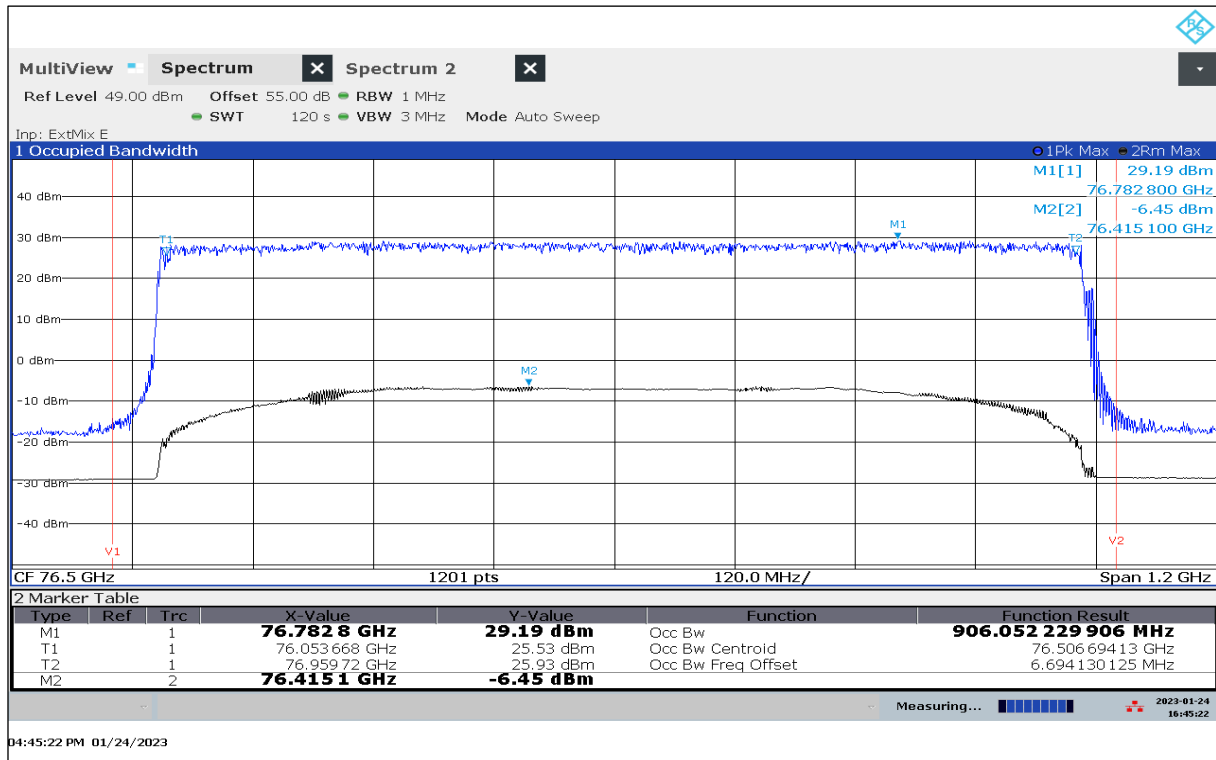

Plot 16: OBW, Mode 39, $T_{nom} / V_{min-max}$

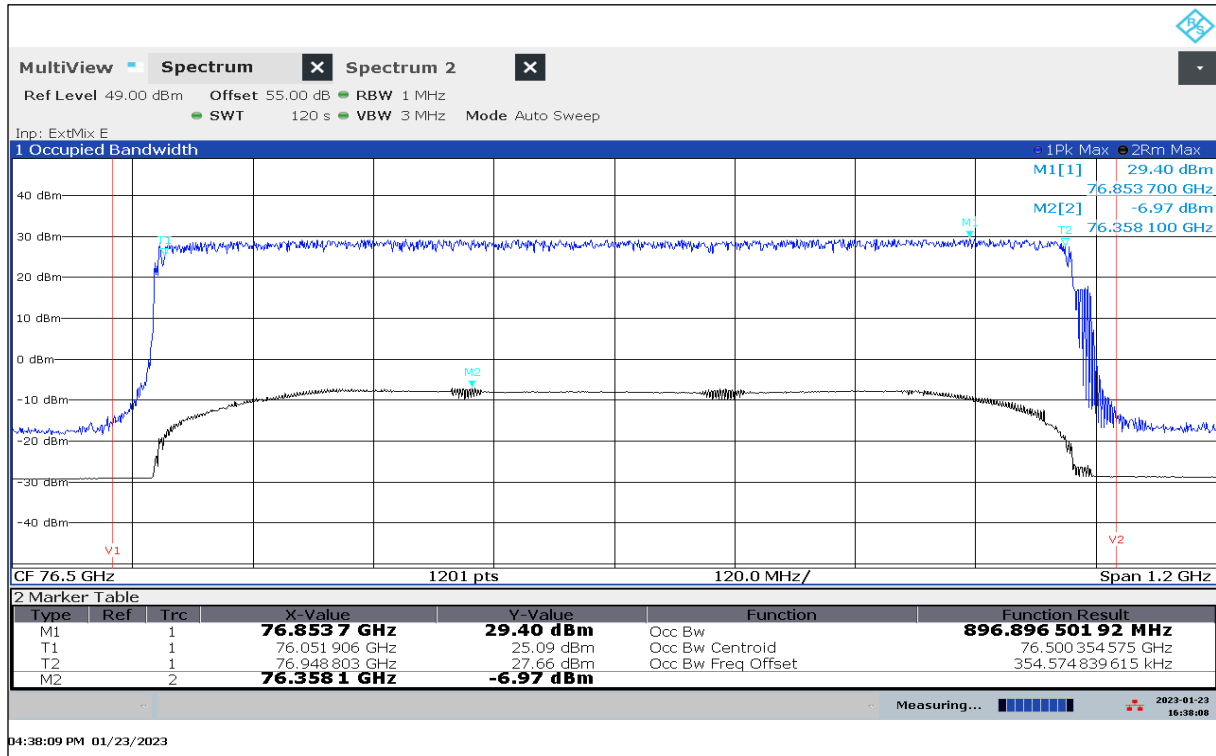

Plot 17: OBW, Mode 39, $T_{min} / V_{min-max}$

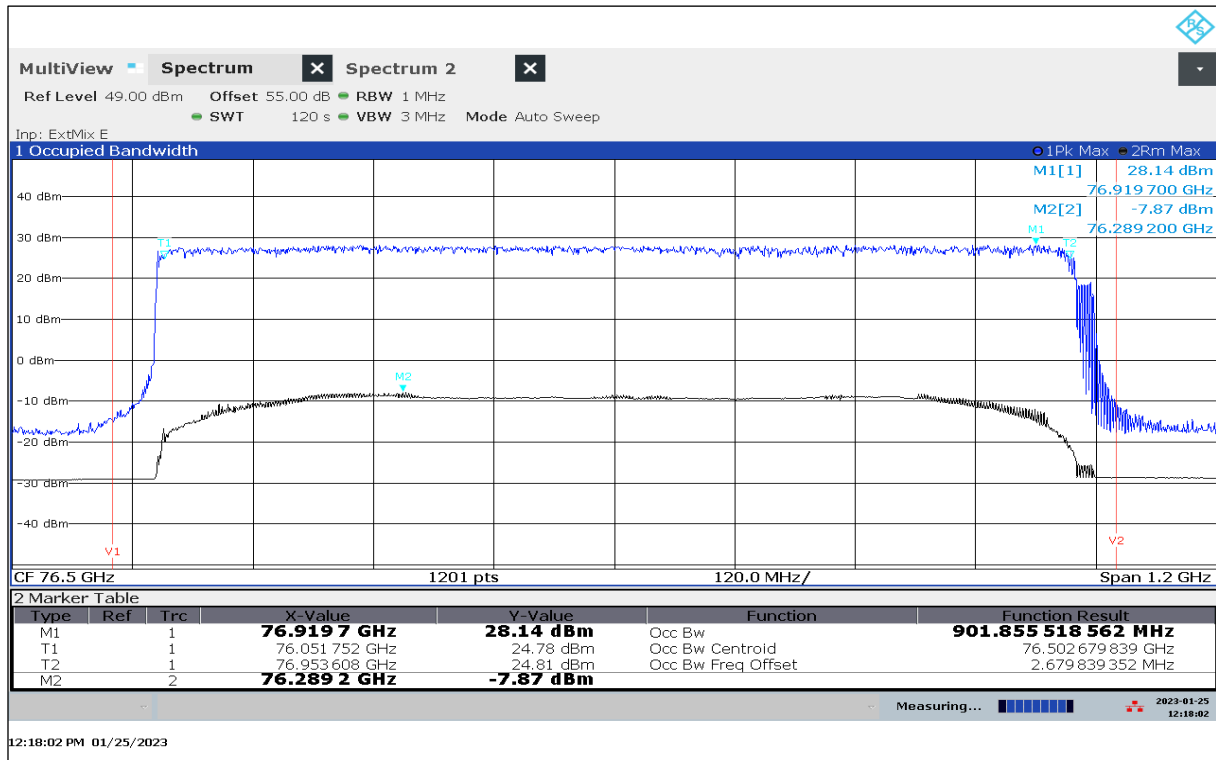

Plot 18: OBW, Mode 39, $T_{max} / V_{min-max}$

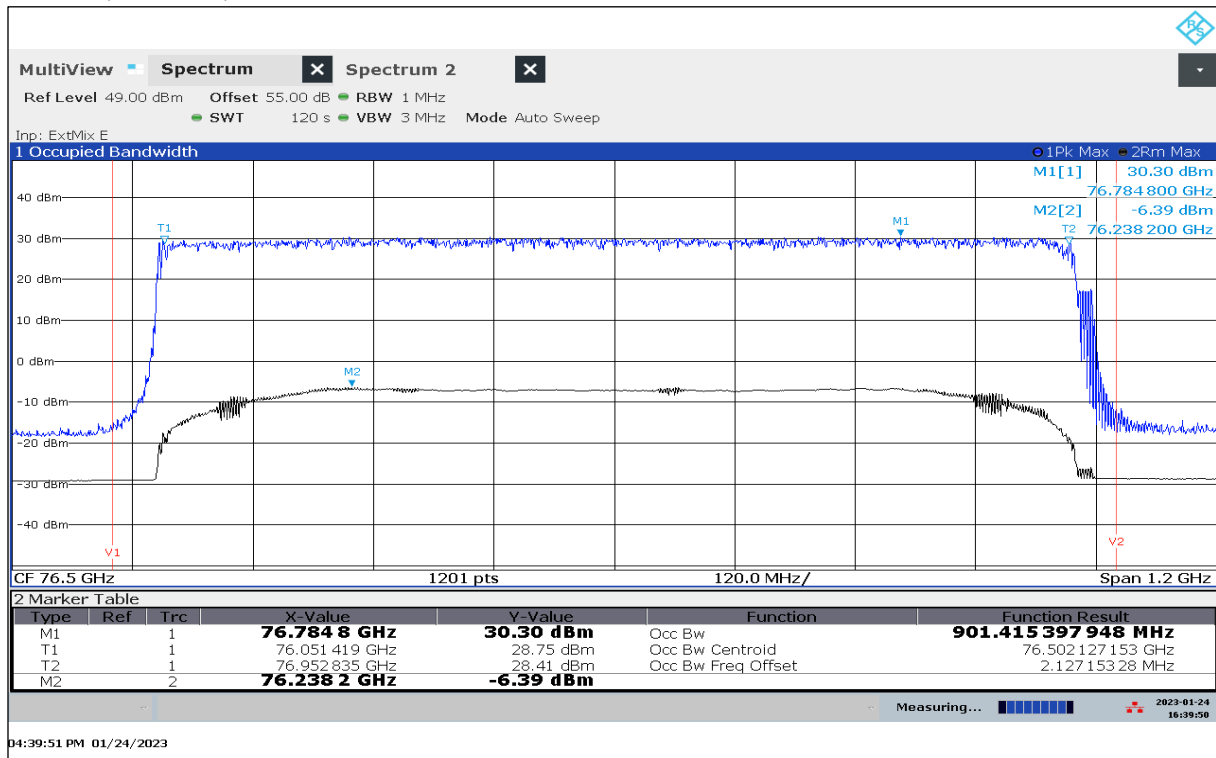

Plot 19: OBW, Mode 51, $T_{nom} / V_{min-max}$

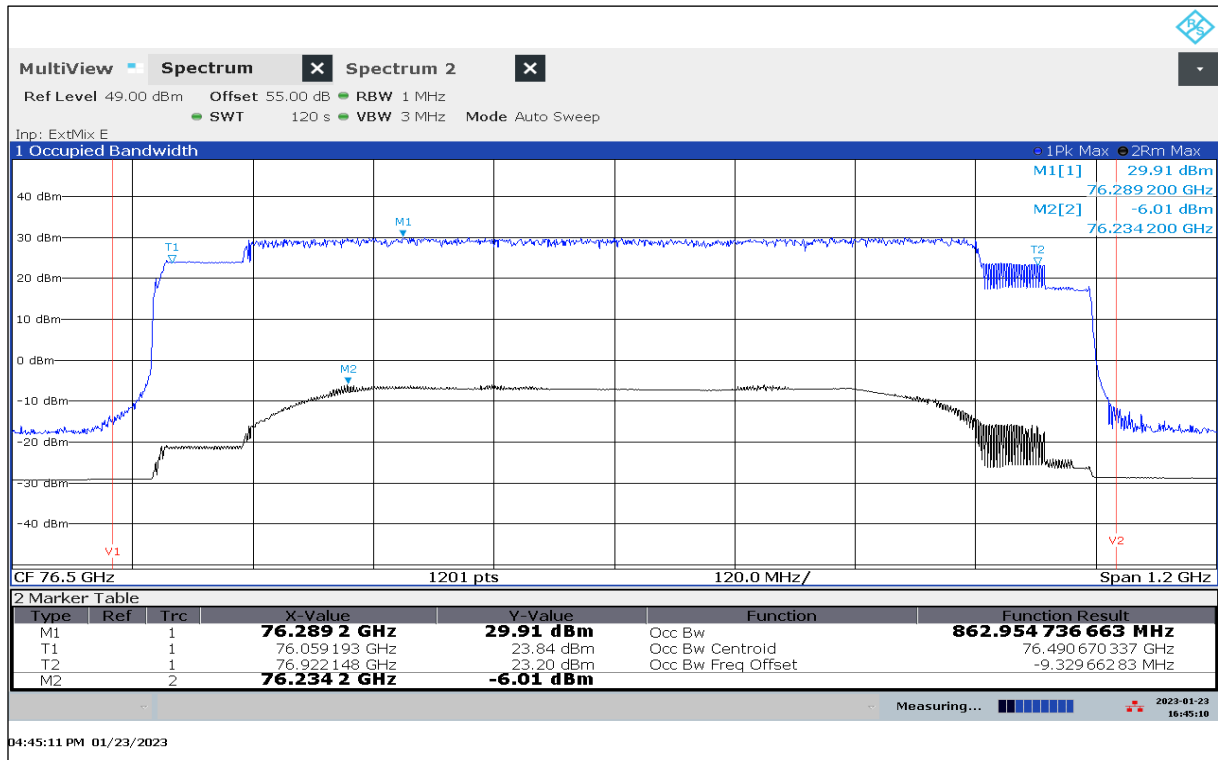

Plot 20: OBW, Mode 51, $T_{min} / V_{min-max}$

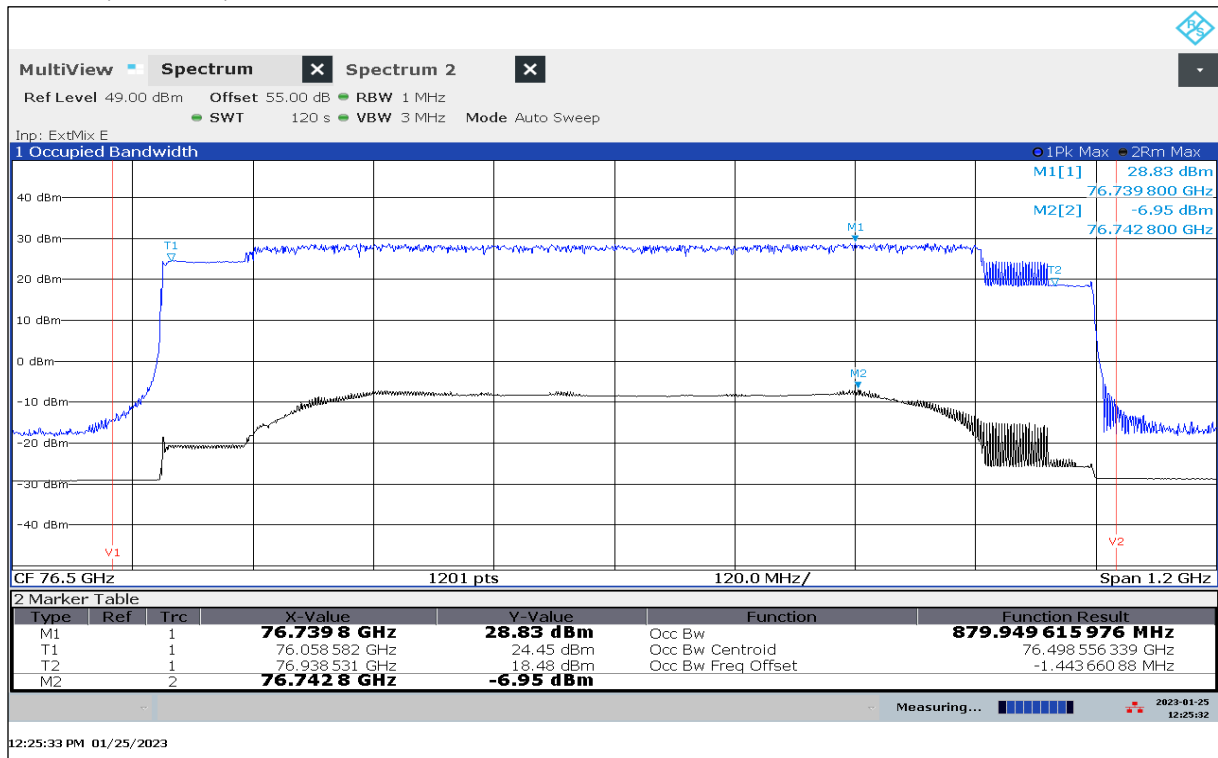

Plot 21: OBW, Mode 51, $T_{max} / V_{min-max}$

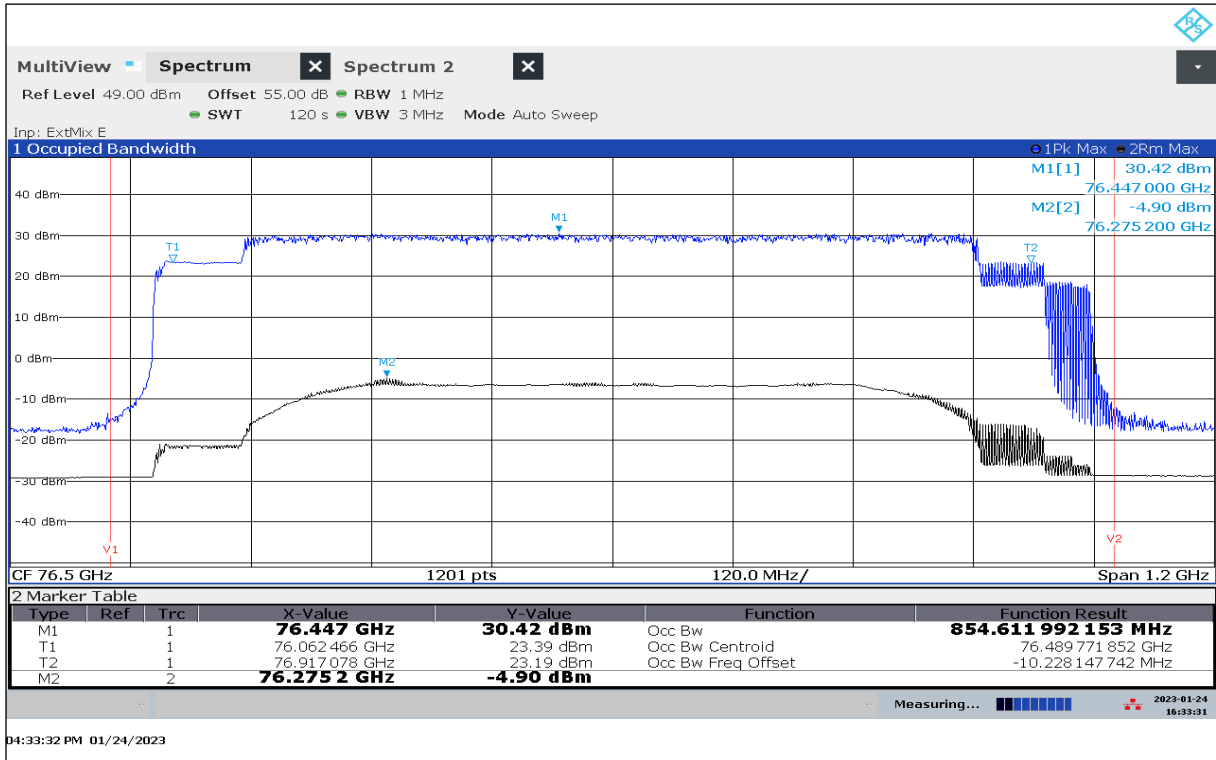

Plot 22: OBW, Mode 63, $T_{nom} / V_{min-max}$

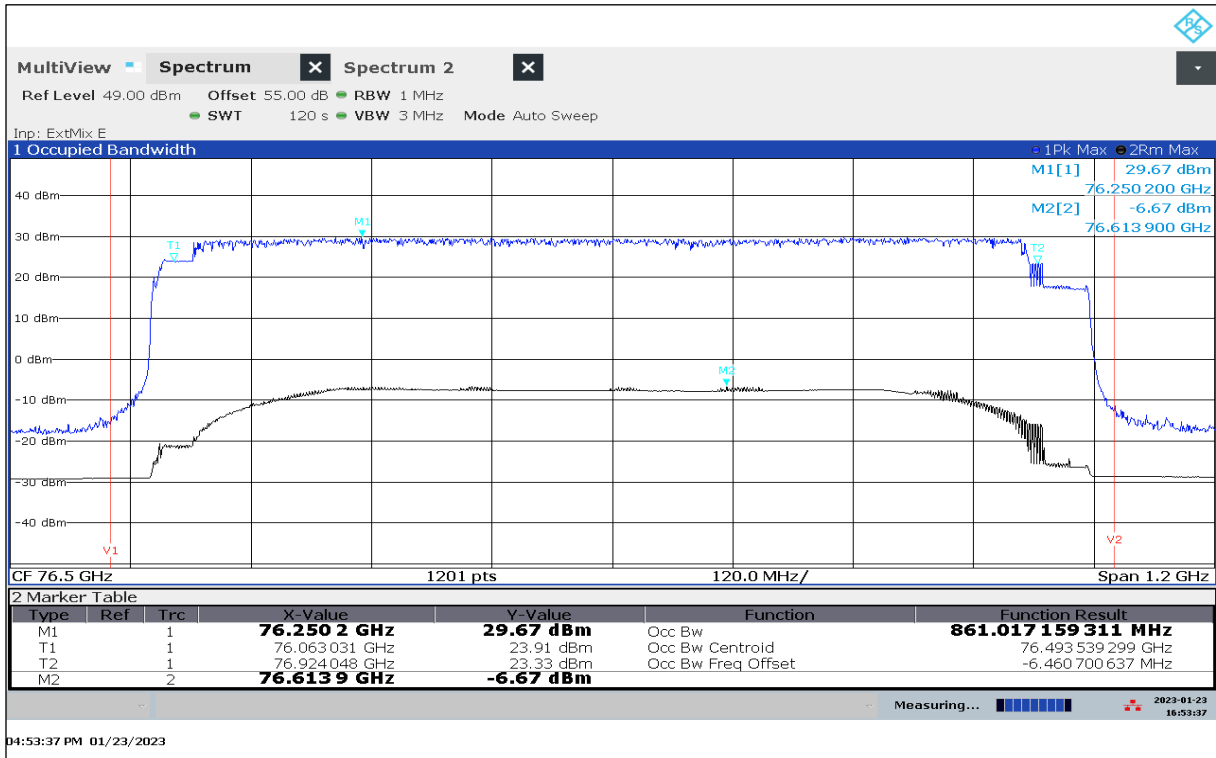

Plot 23: OBW, Mode 63, $T_{min} / V_{min-max}$

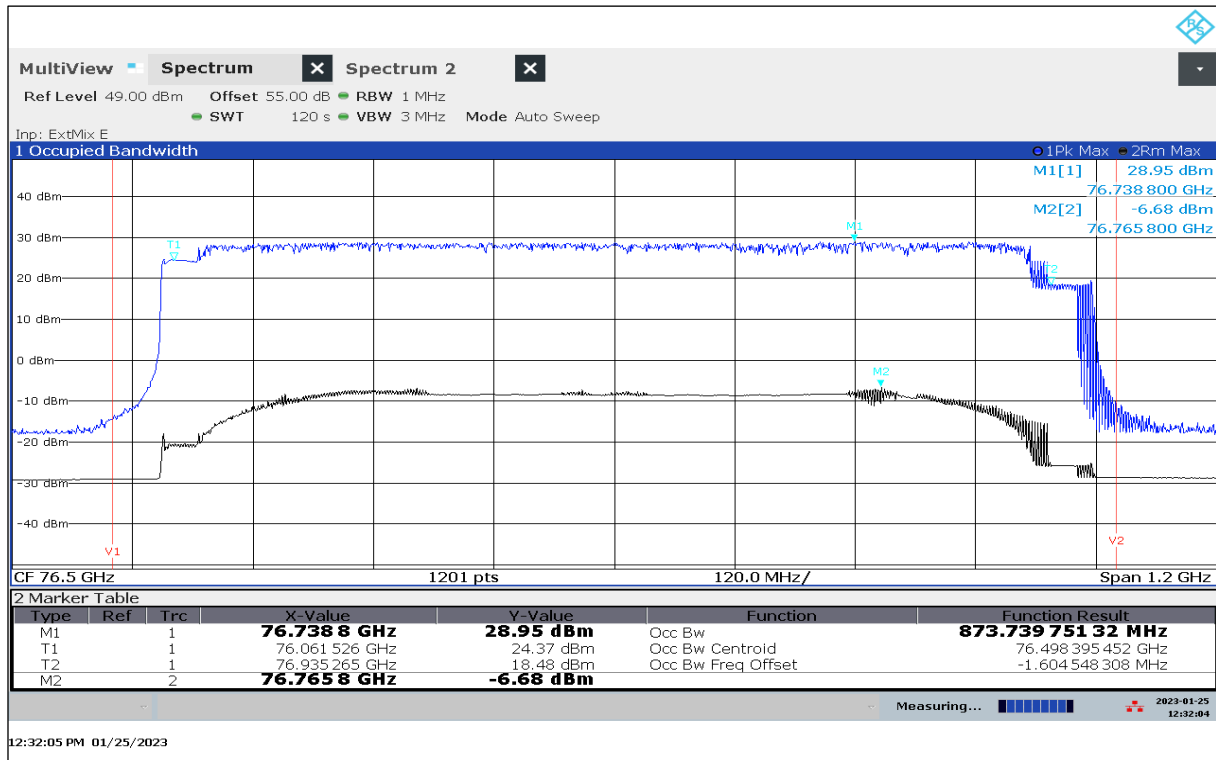

Plot 24: OBW, Mode 63, $T_{max} / V_{min-max}$

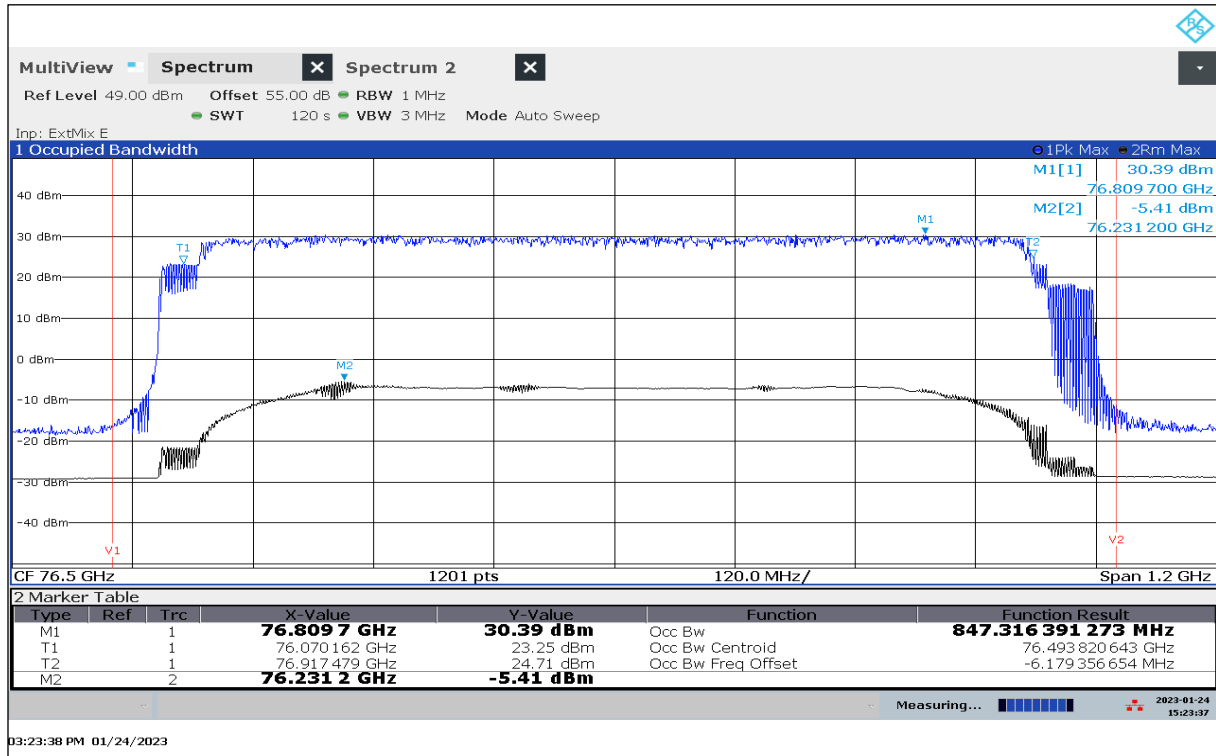

Plot 25: OBW, Mode 80, $T_{nom} / V_{min-max}$

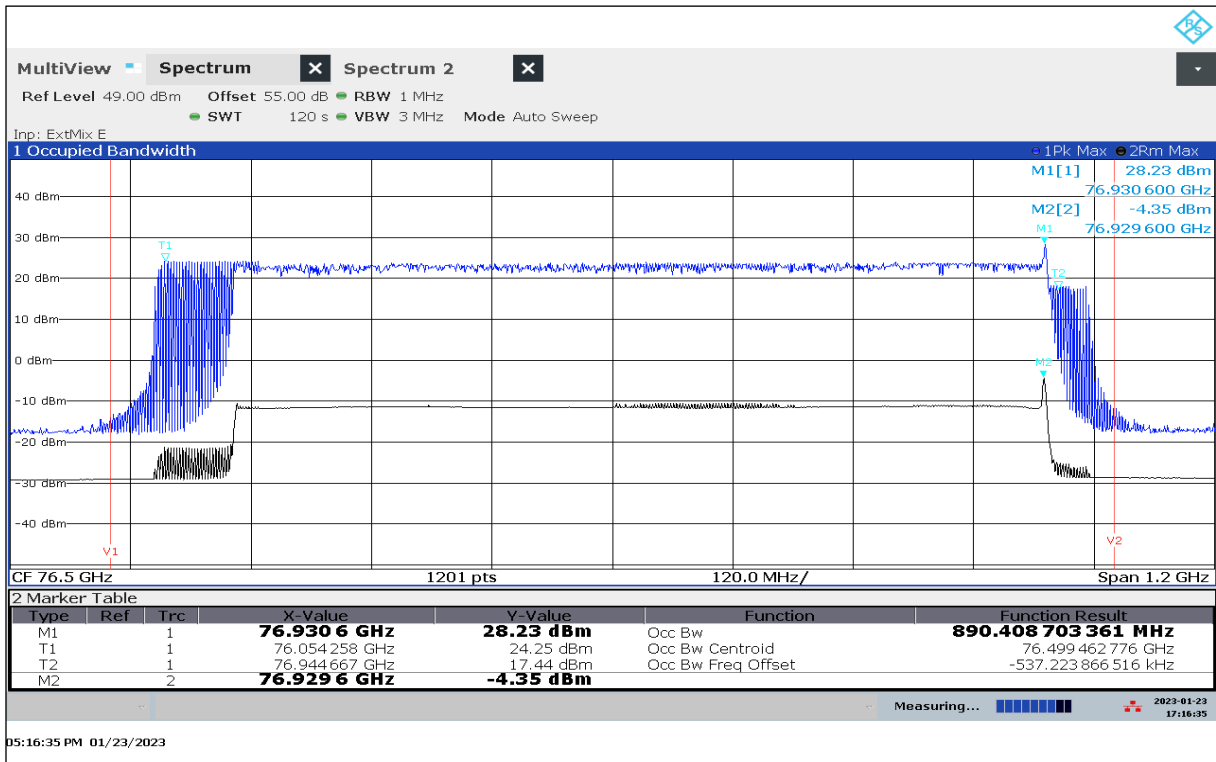

Plot 26: OBW, Mode 80, $T_{min} / V_{min-max}$

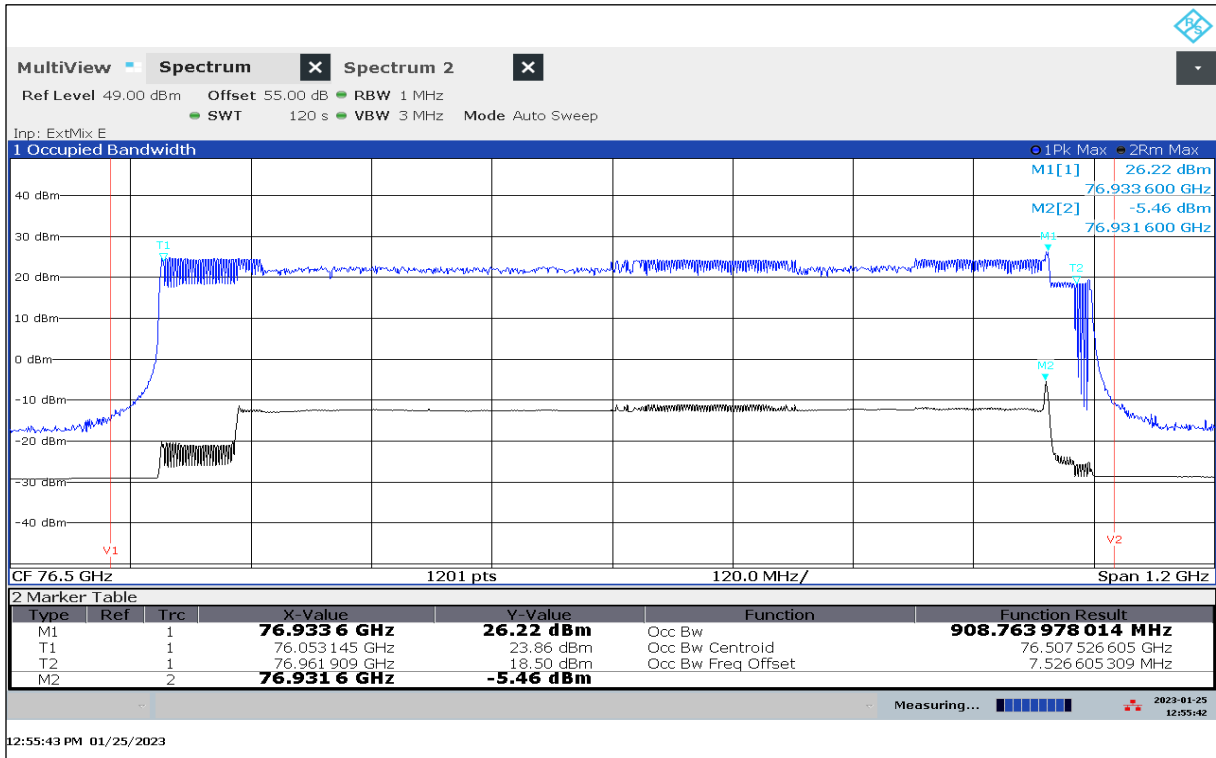

Plot 27: OBW, Mode 80, $T_{max} / V_{min-max}$

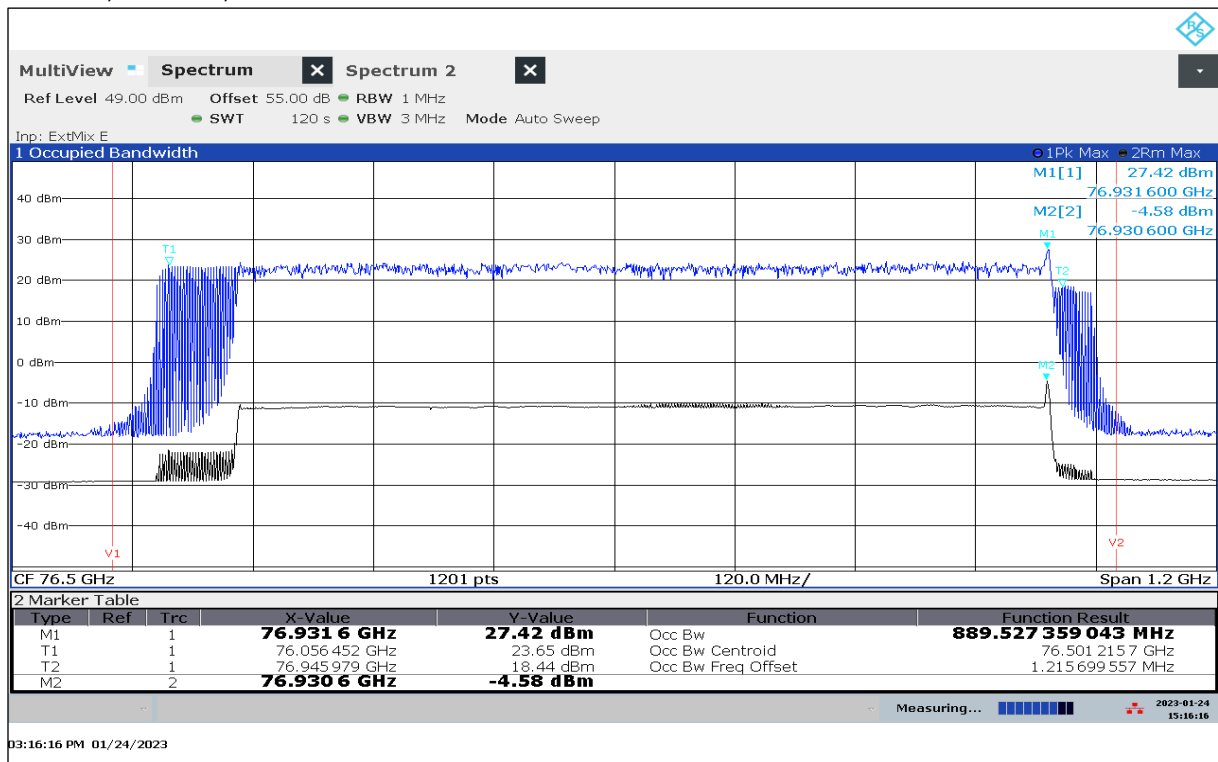

Plot 28: EIRP Mean Power (Channel Power), Mode 03, RMS detector, $T_{nom} / V_{min-max}$

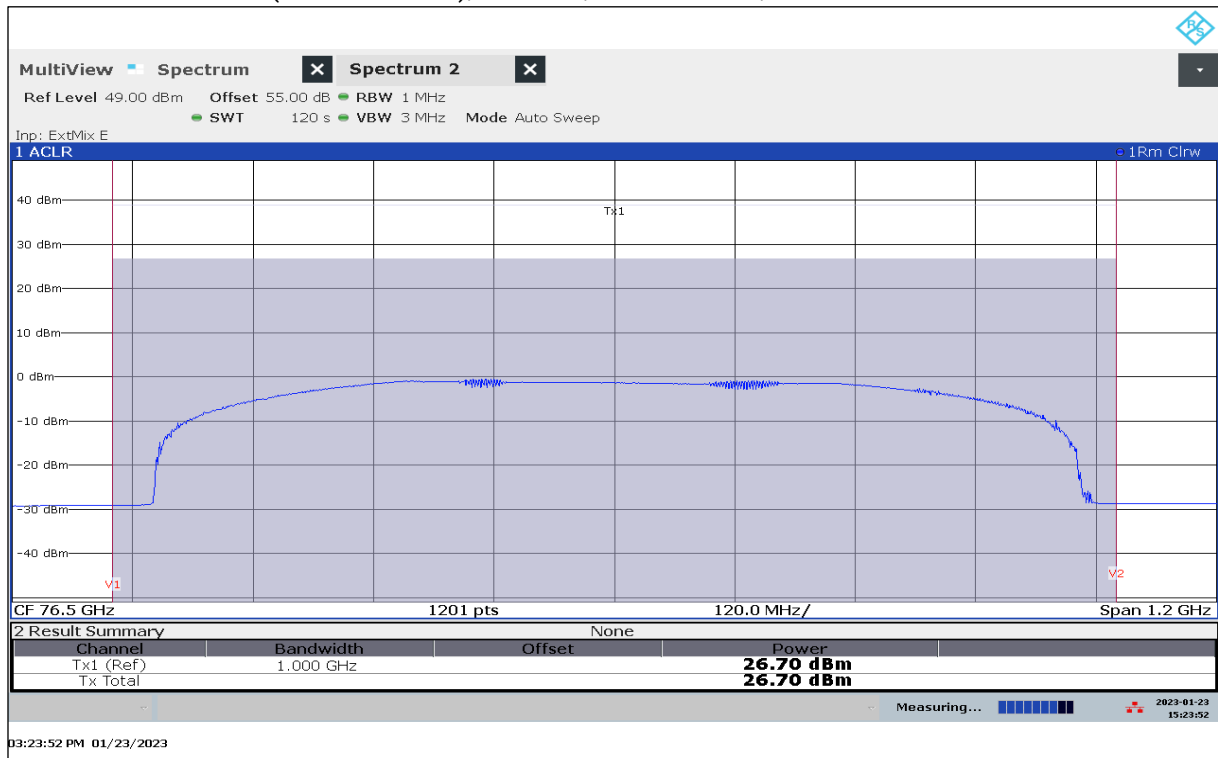

Plot 29: EIRP Mean Power (Channel Power), Mode 03, RMS detector, $T_{min} / V_{min-max}$

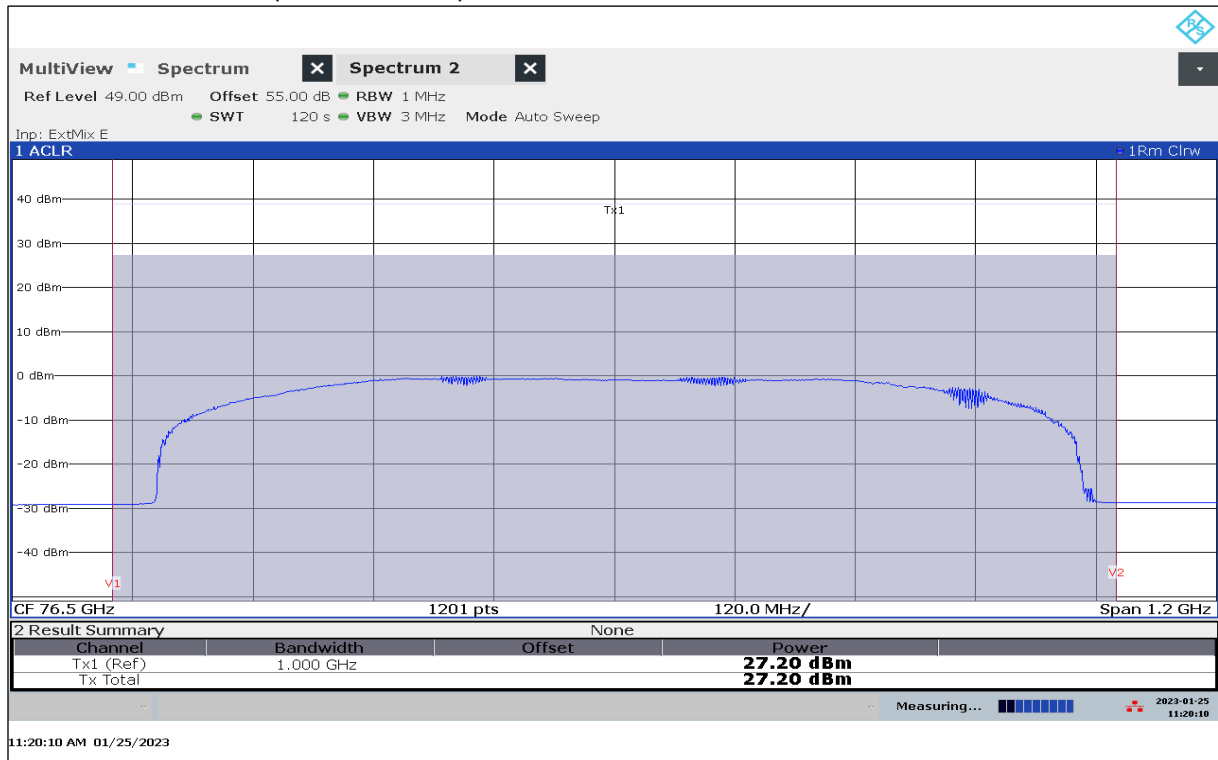

Plot 30: EIRP Mean Power (Channel Power), Mode 03, RMS detector, $T_{max} / V_{min-max}$

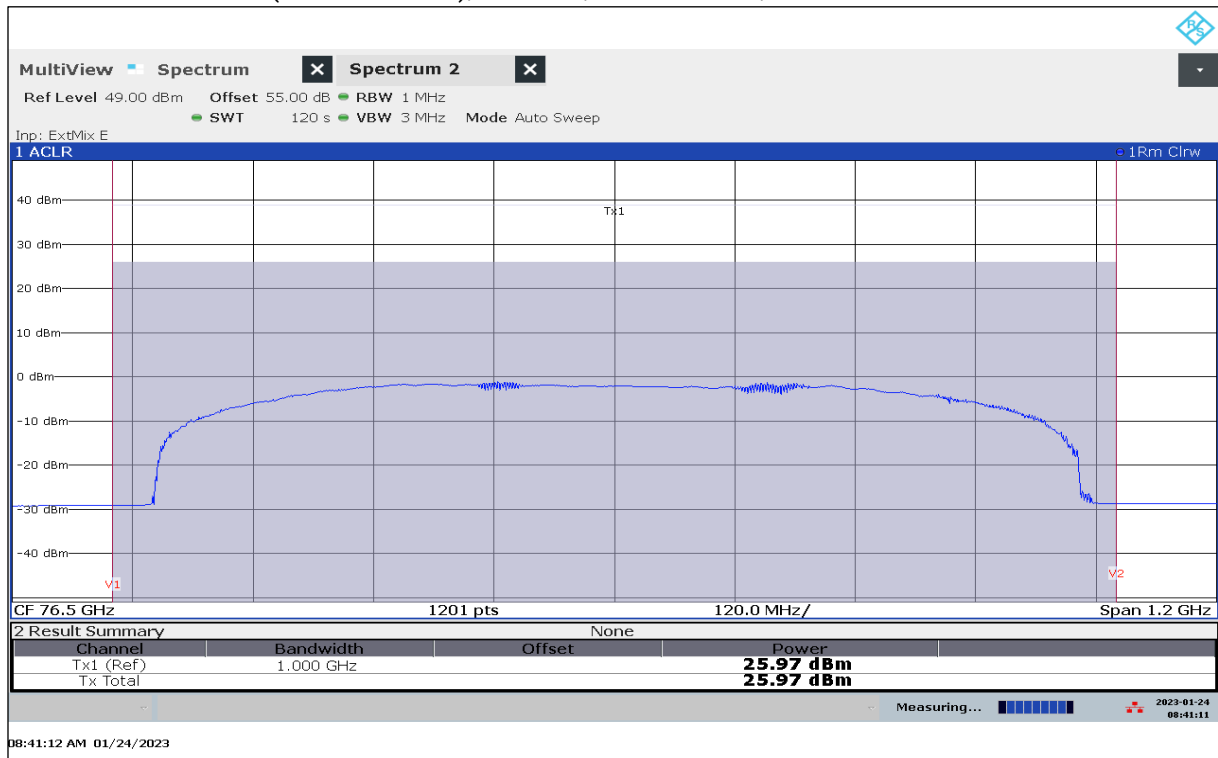

Plot 31: EIRP Mean Power (Channel Power), Mode 09, RMS detector, $T_{nom} / V_{min-max}$

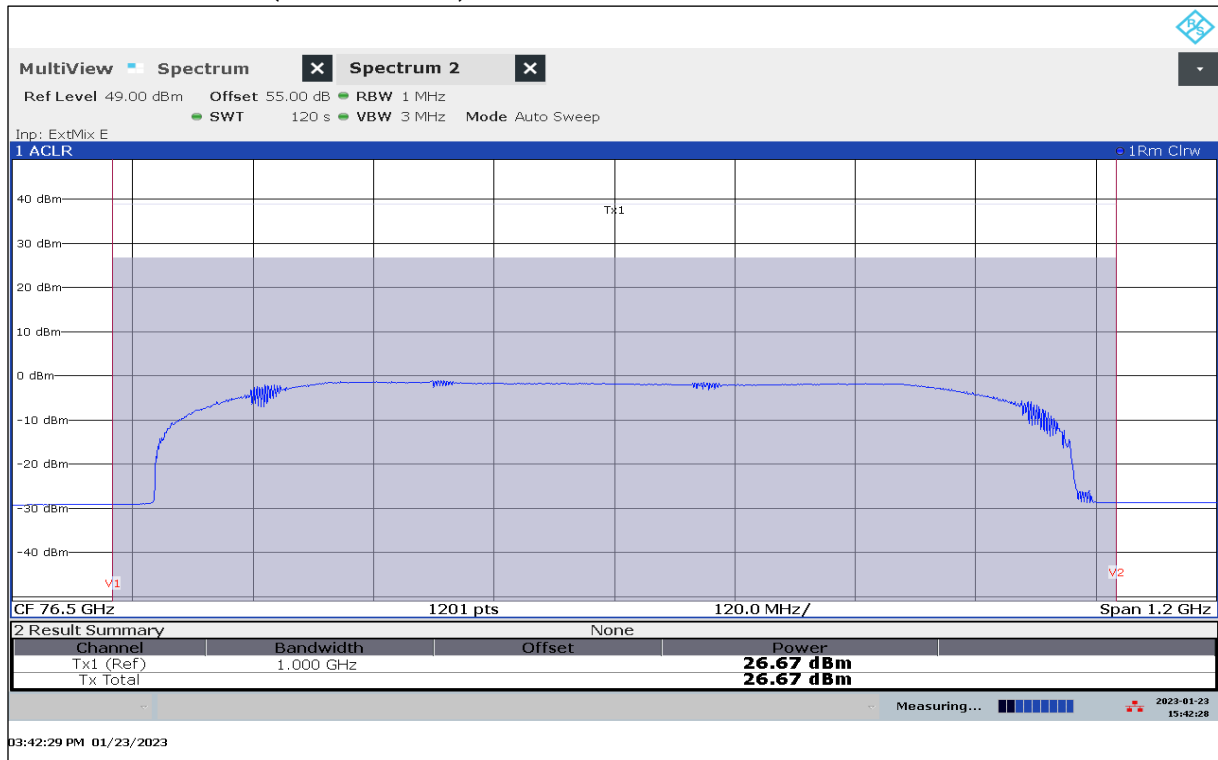

Plot 32: EIRP Mean Power (Channel Power), Mode 09, RMS detector, $T_{min} / V_{min-max}$

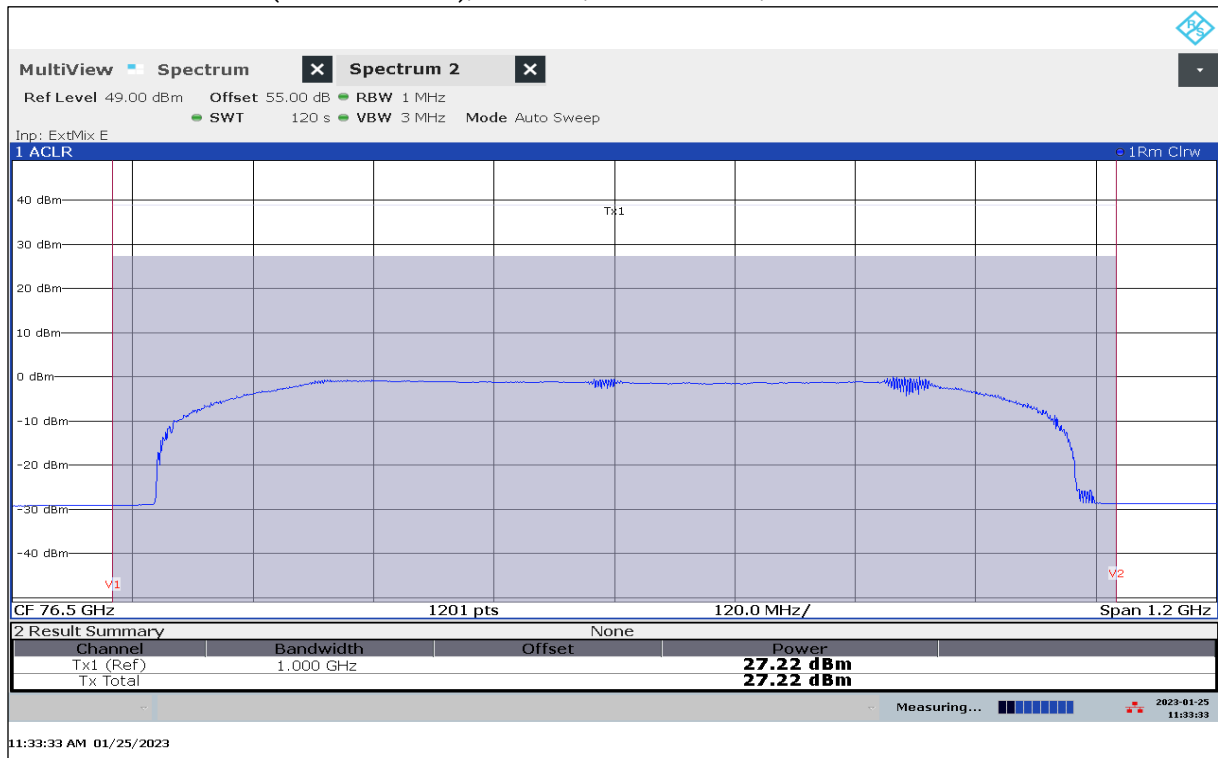

Plot 33: EIRP Mean Power (Channel Power), Mode 09, RMS detector, T_{max} / $V_{min-max}$

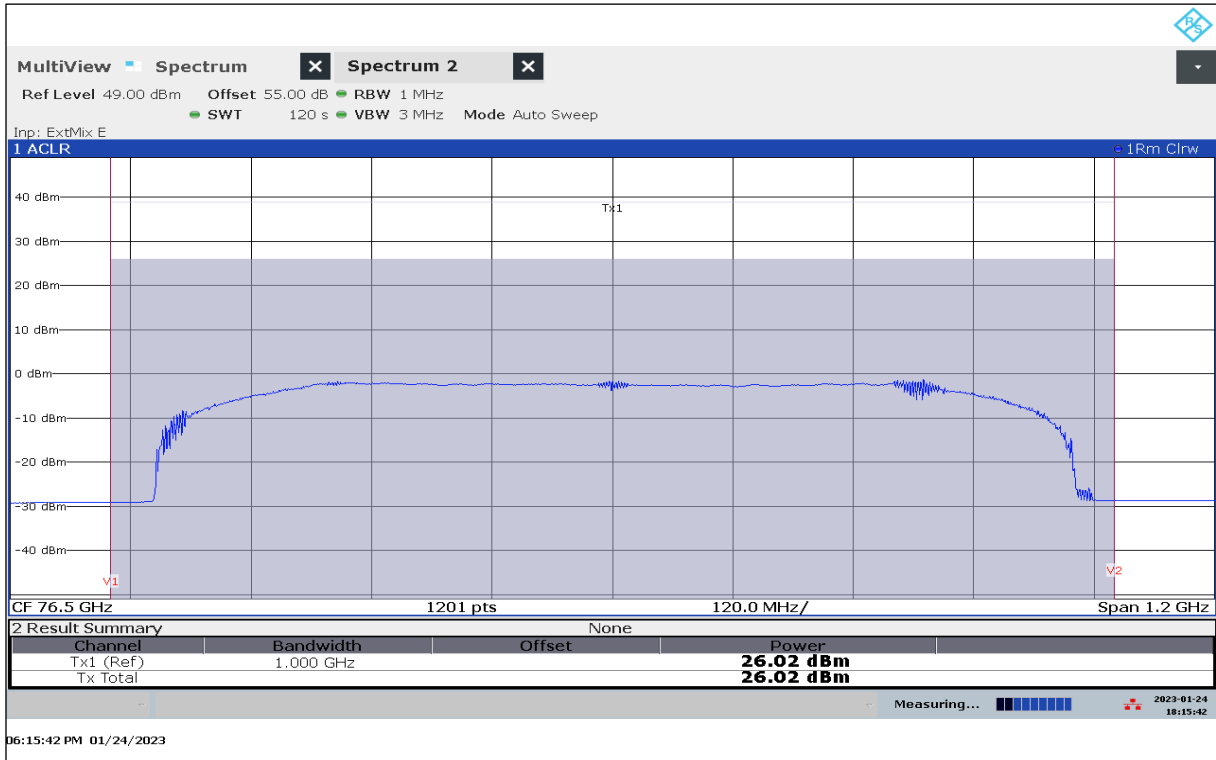

Plot 34: EIRP Mean Power (Channel Power), Mode 15, RMS detector, T_{nom} / $V_{min-max}$

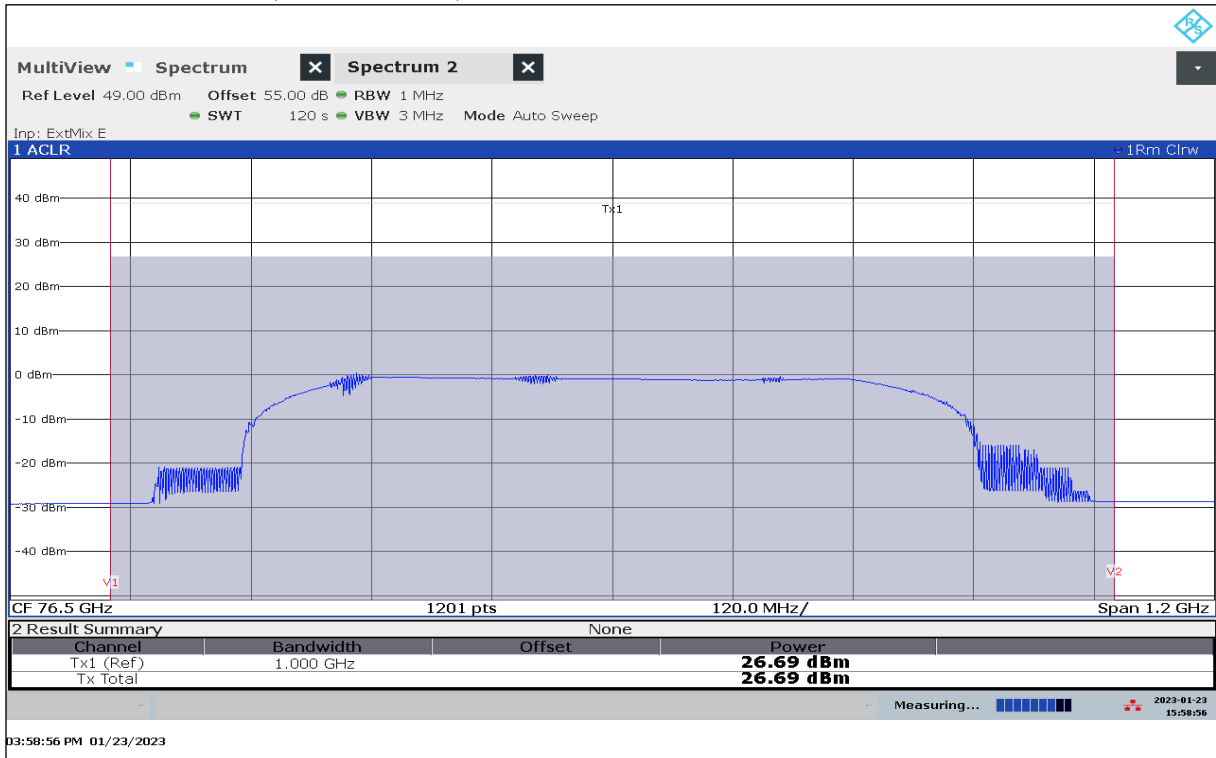

Plot 35: EIRP Mean Power (Channel Power), Mode 15, RMS detector, $T_{min} / V_{min-max}$

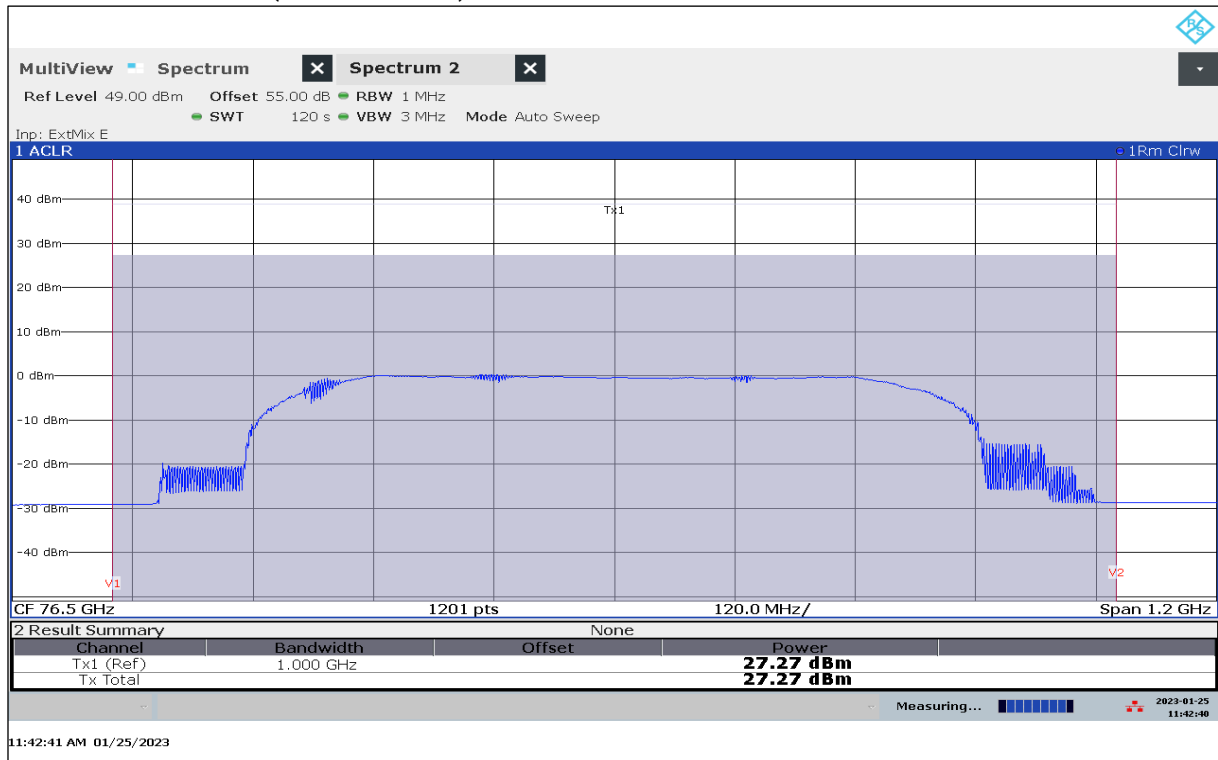

Plot 36: EIRP Mean Power (Channel Power), Mode 15, RMS detector, $T_{max} / V_{min-max}$

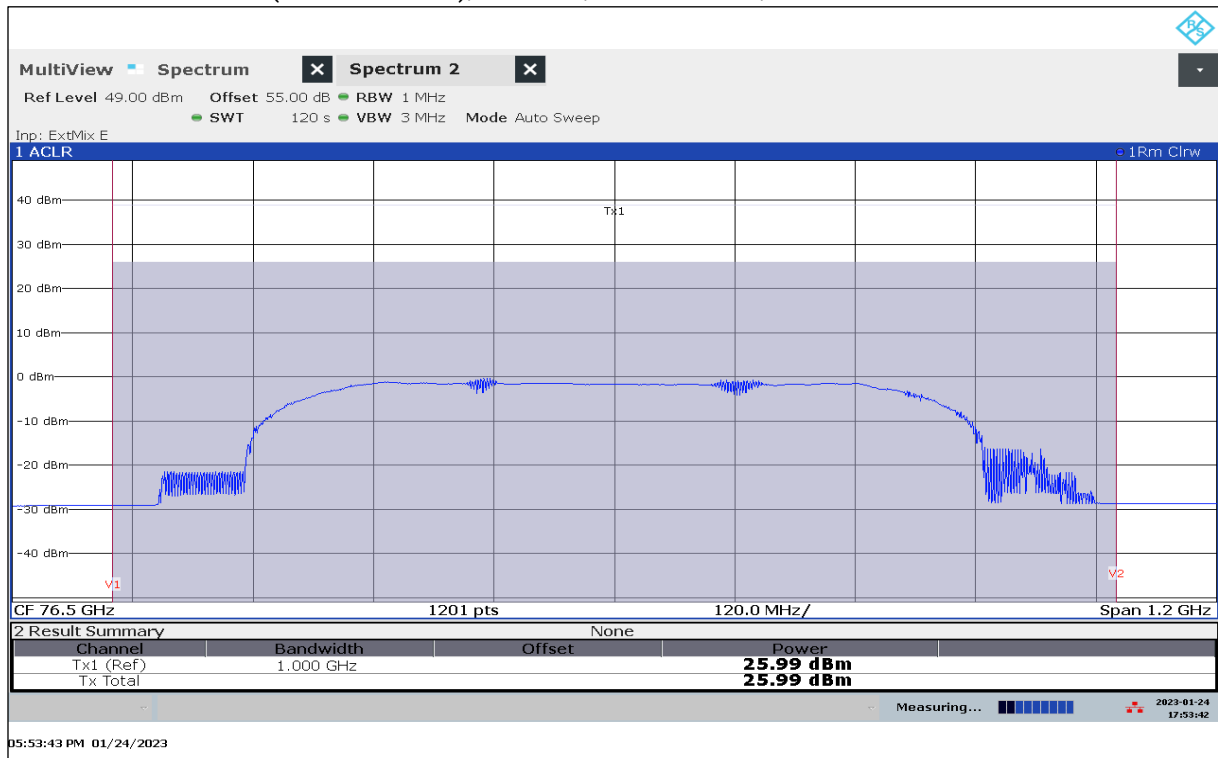

Plot 37: EIRP Mean Power (Channel Power), Mode 21, RMS detector, $T_{nom} / V_{min-max}$

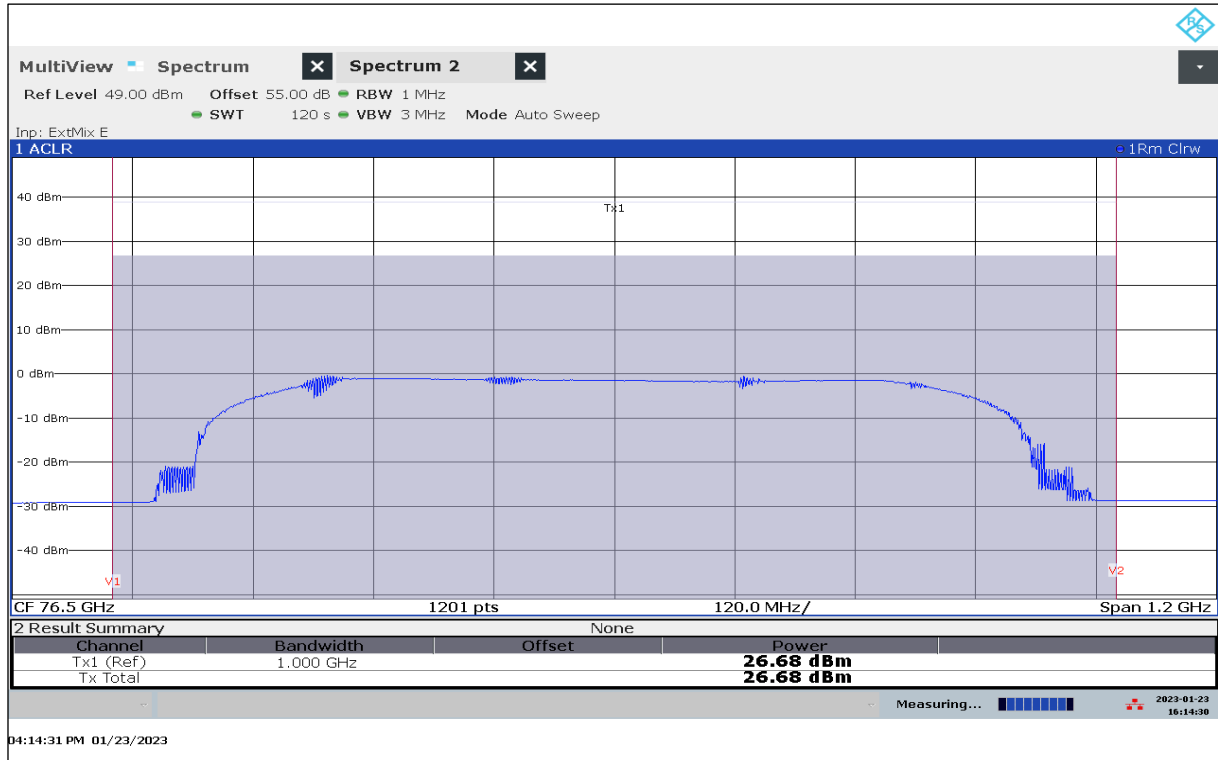

Plot 38: EIRP Mean Power (Channel Power), Mode 21, RMS detector, $T_{min} / V_{min-max}$

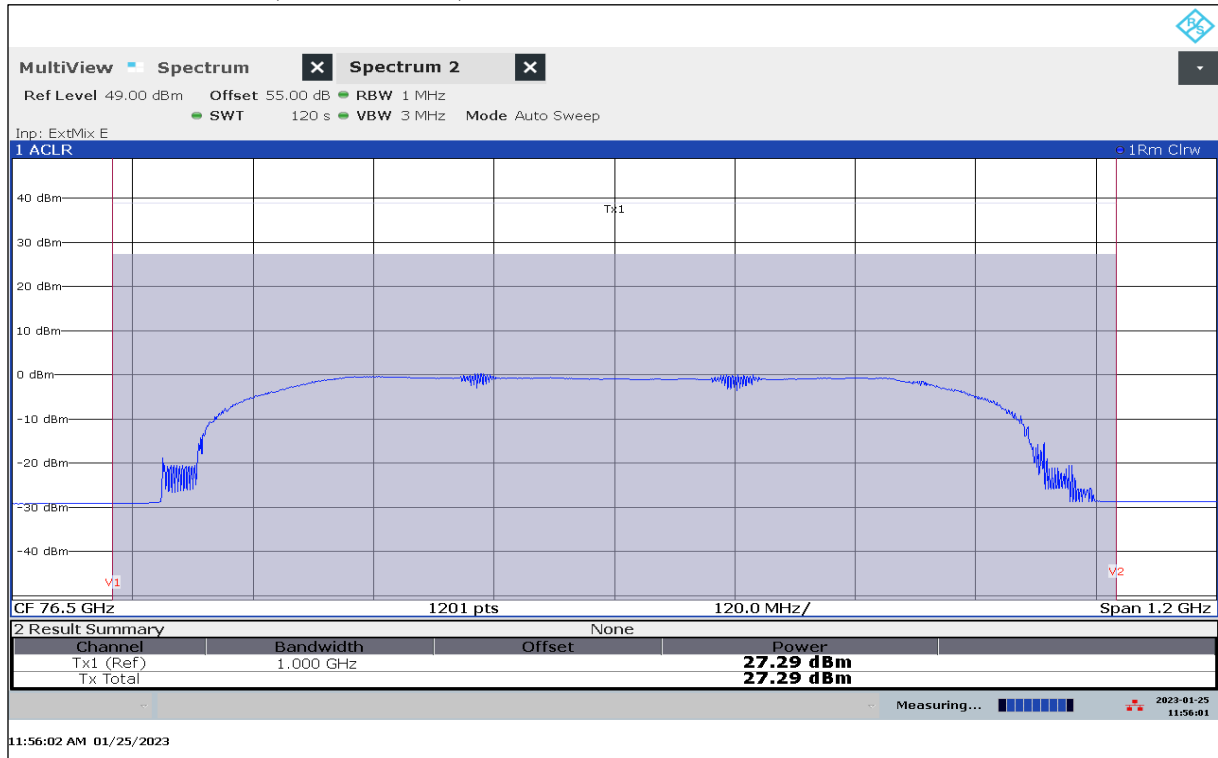

Plot 39: EIRP Mean Power (Channel Power), Mode 21, RMS detector, $T_{max} / V_{min-max}$

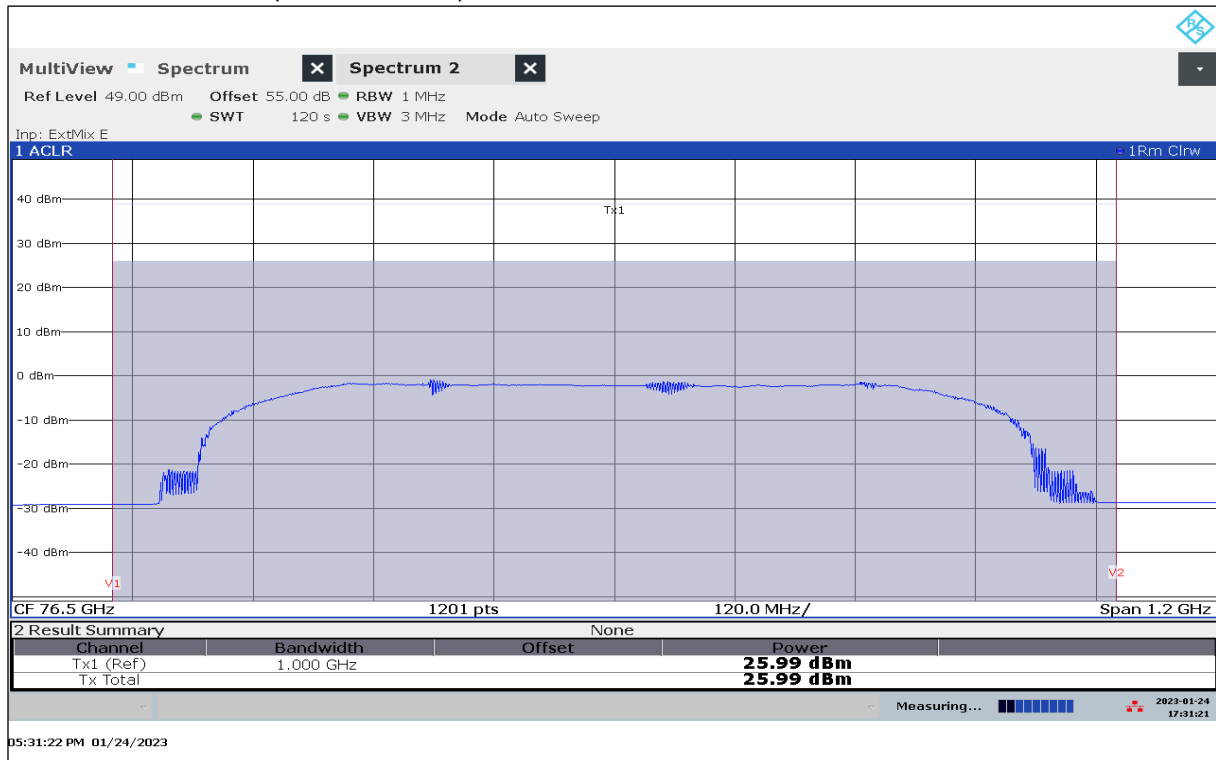

Plot 40: EIRP Mean Power (Channel Power), Mode 27, RMS detector, $T_{nom} / V_{min-max}$

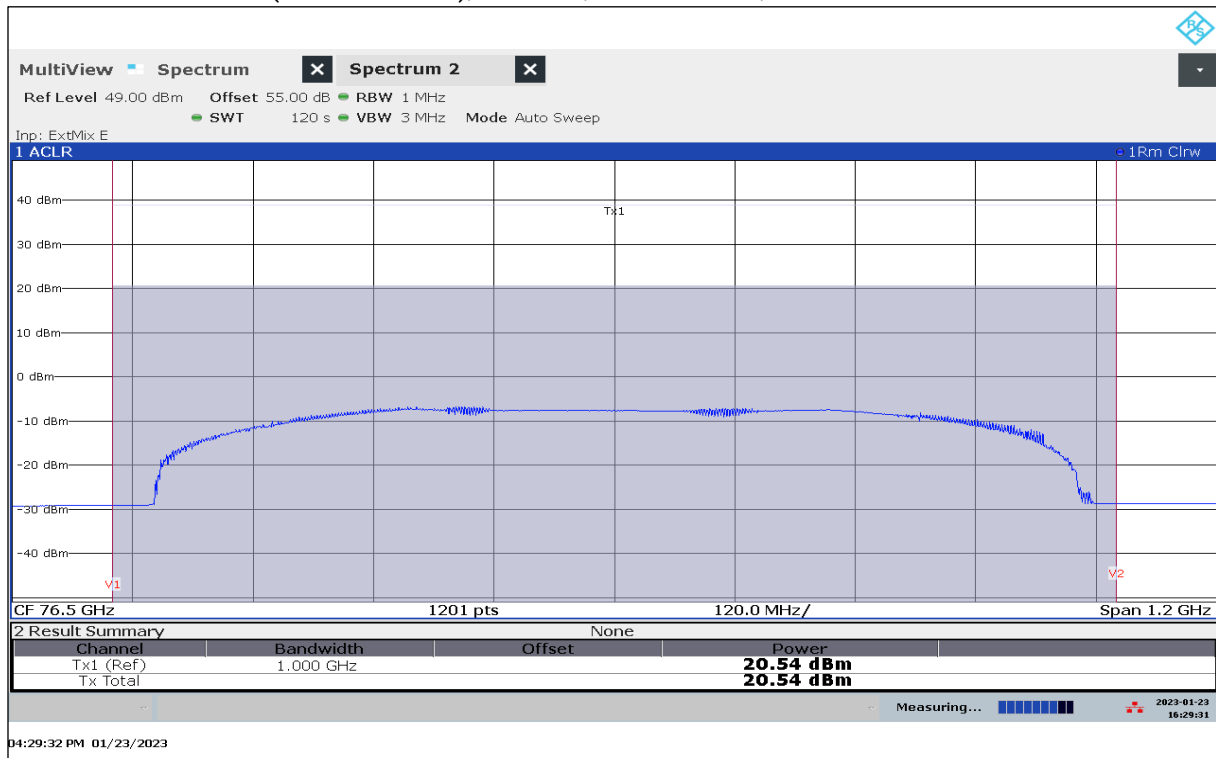

Plot 41: EIRP Mean Power (Channel Power), Mode 27, RMS detector, $T_{min} / V_{min-max}$

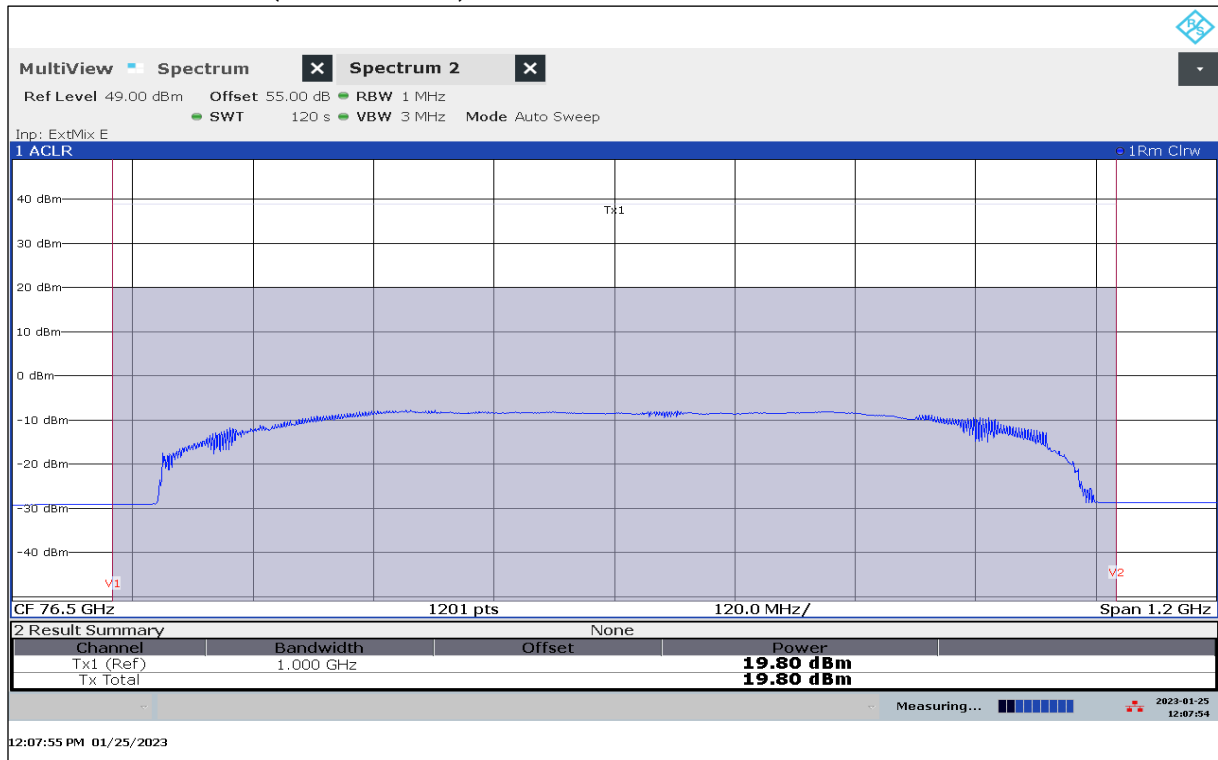

Plot 42: EIRP Mean Power (Channel Power), Mode 27, RMS detector, $T_{max} / V_{min-max}$

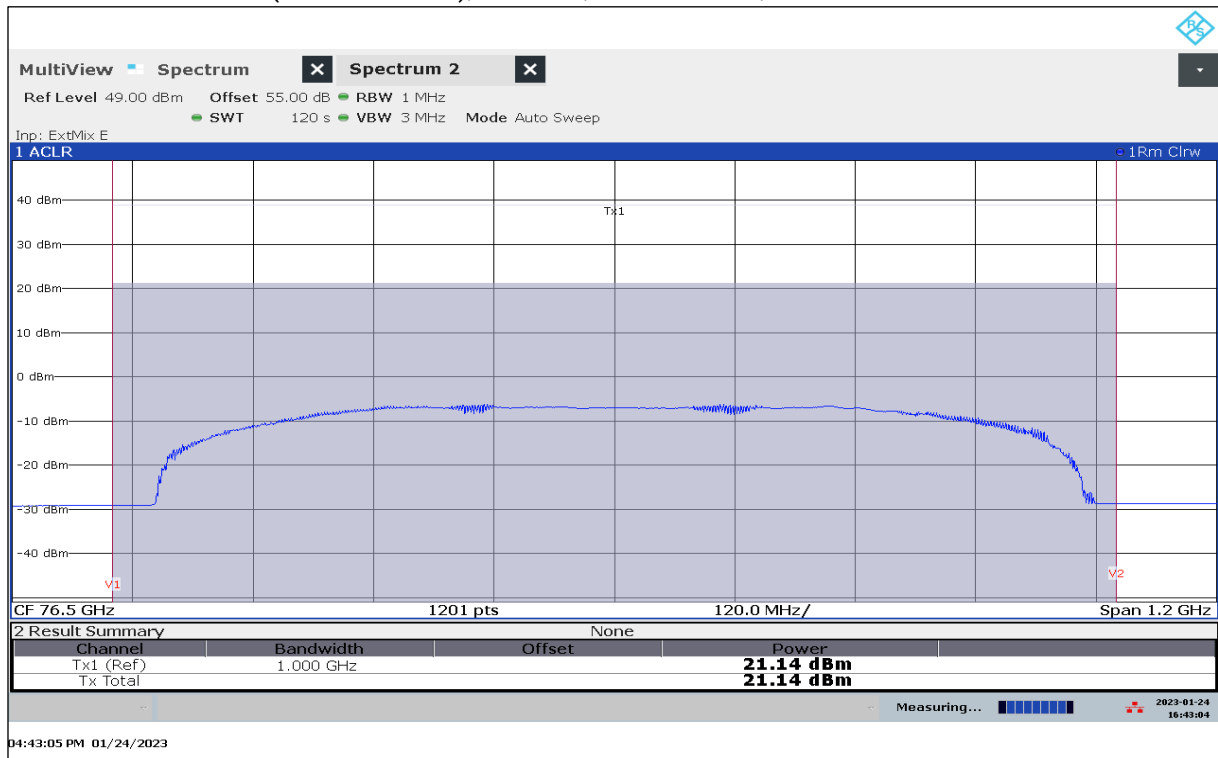

Plot 43: EIRP Mean Power (Channel Power), Mode 39, RMS detector, $T_{nom} / V_{min-max}$



Plot 44: EIRP Mean Power (Channel Power), Mode 39, RMS detector, $T_{min} / V_{min-max}$

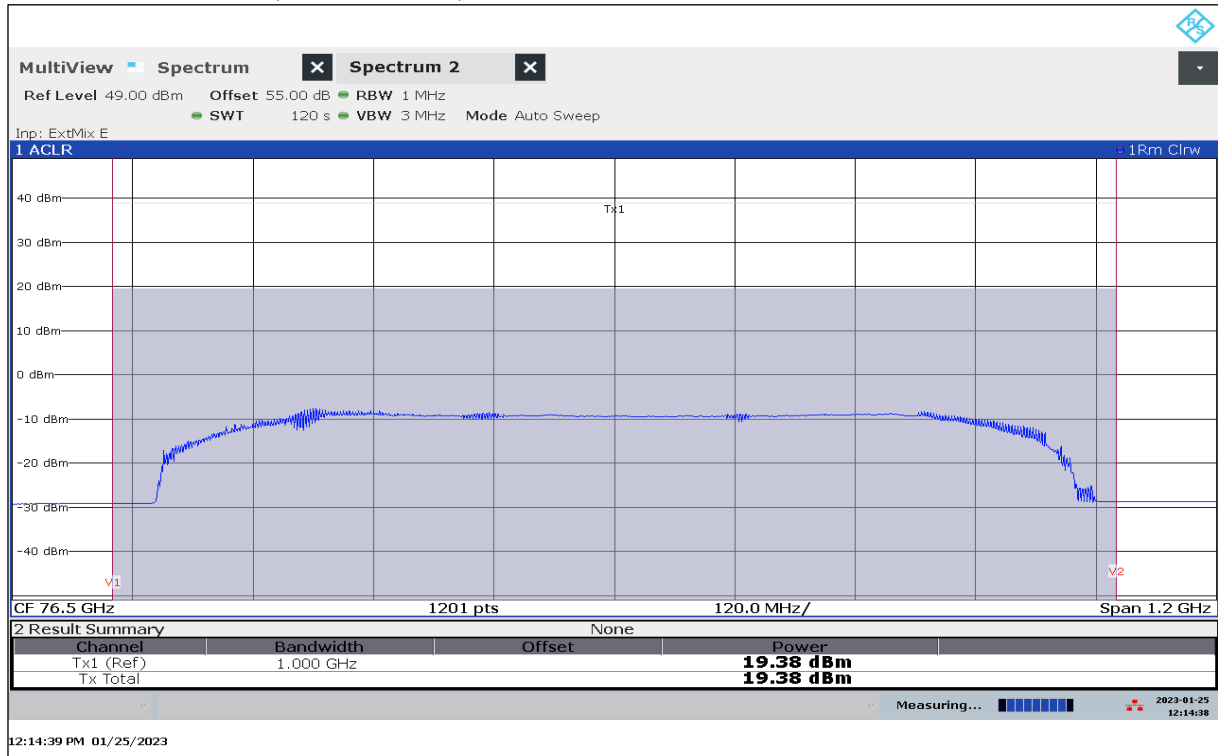

Plot 45: EIRP Mean Power (Channel Power), Mode 39, RMS detector, $T_{max} / V_{min-max}$

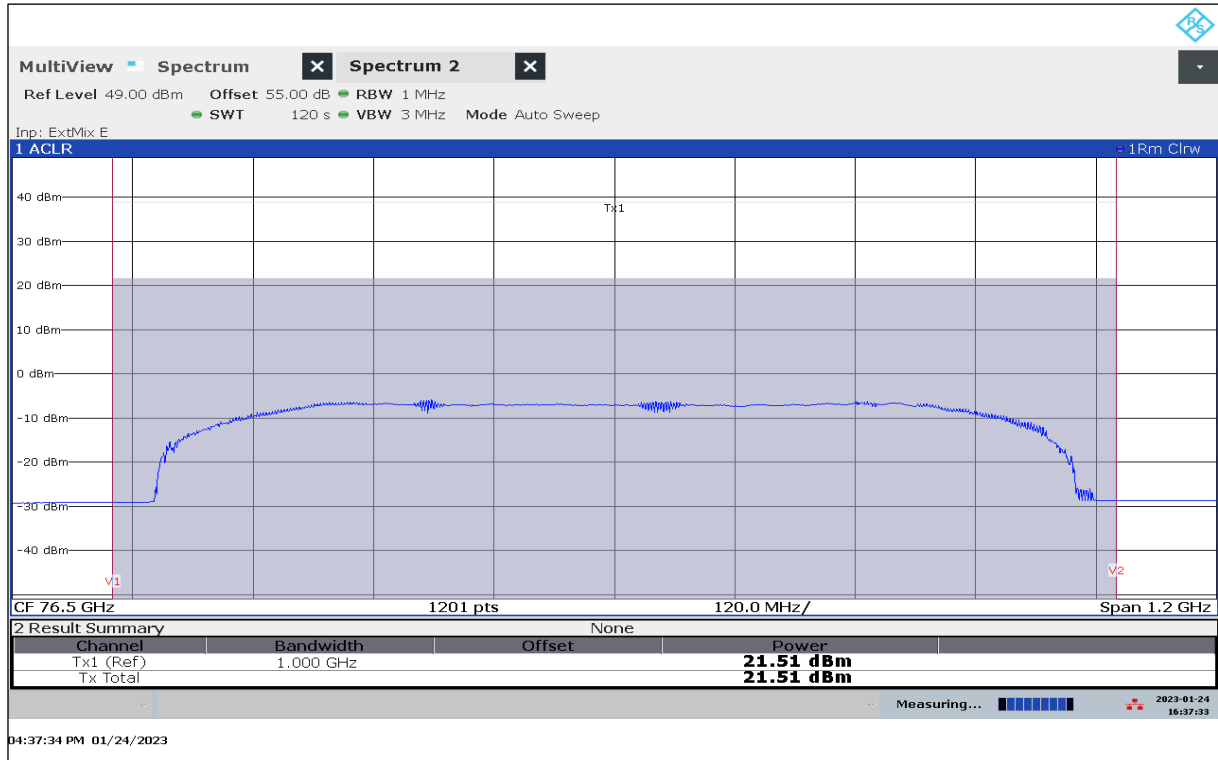

Plot 46: EIRP Mean Power (Channel Power), Mode 51, RMS detector, $T_{nom} / V_{min-max}$

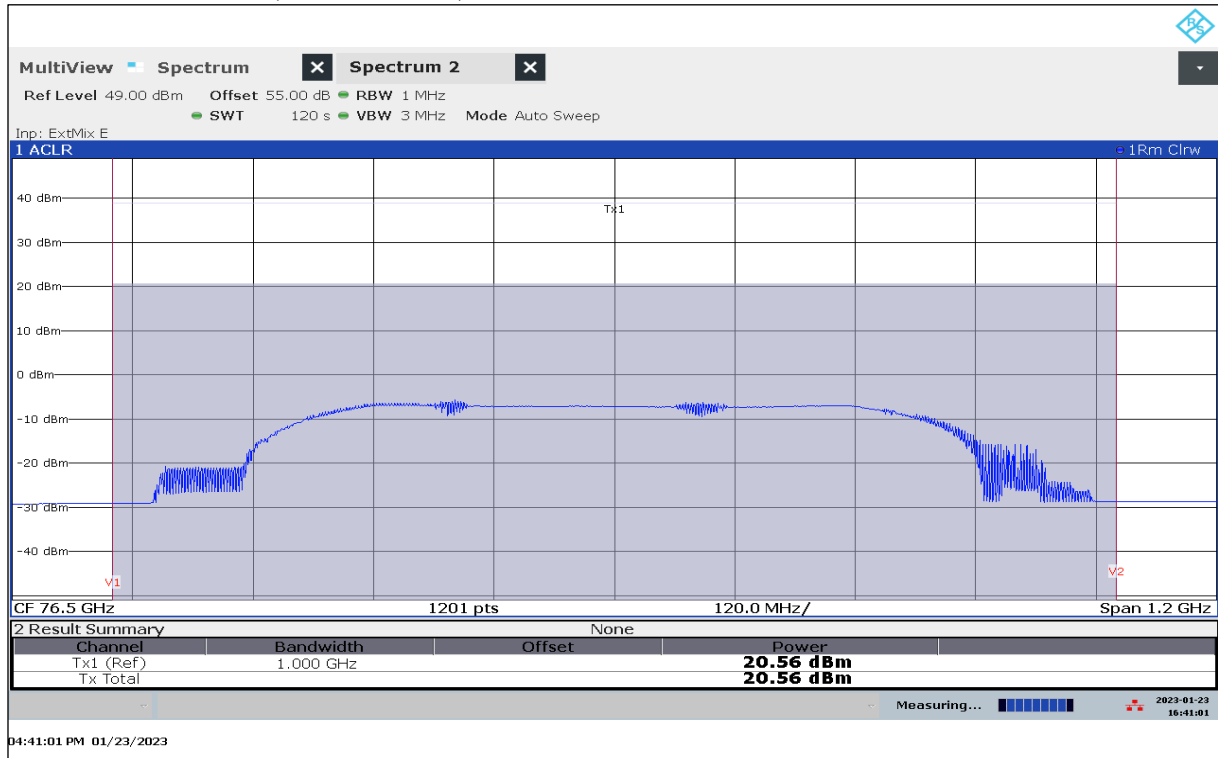

Plot 47: EIRP Mean Power (Channel Power), Mode 51, RMS detector, $T_{min} / V_{min-max}$

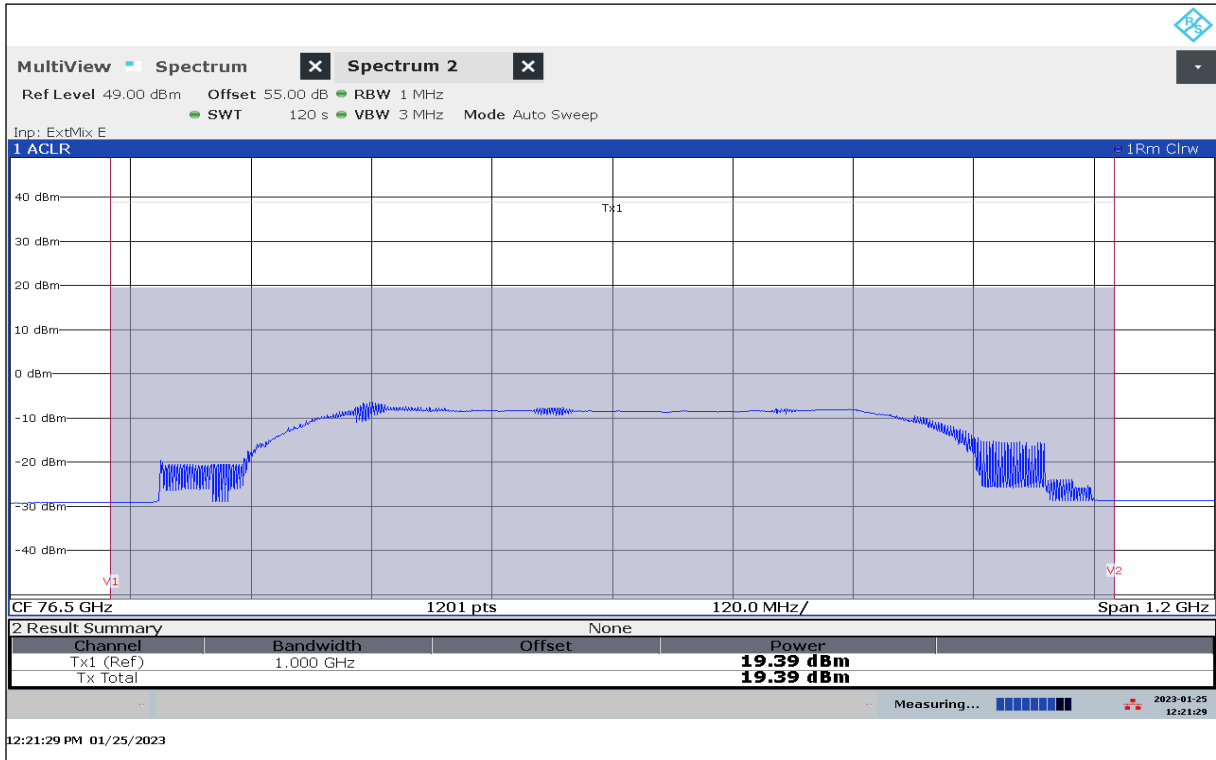

Plot 48: EIRP Mean Power (Channel Power), Mode 51, RMS detector, $T_{max} / V_{min-max}$

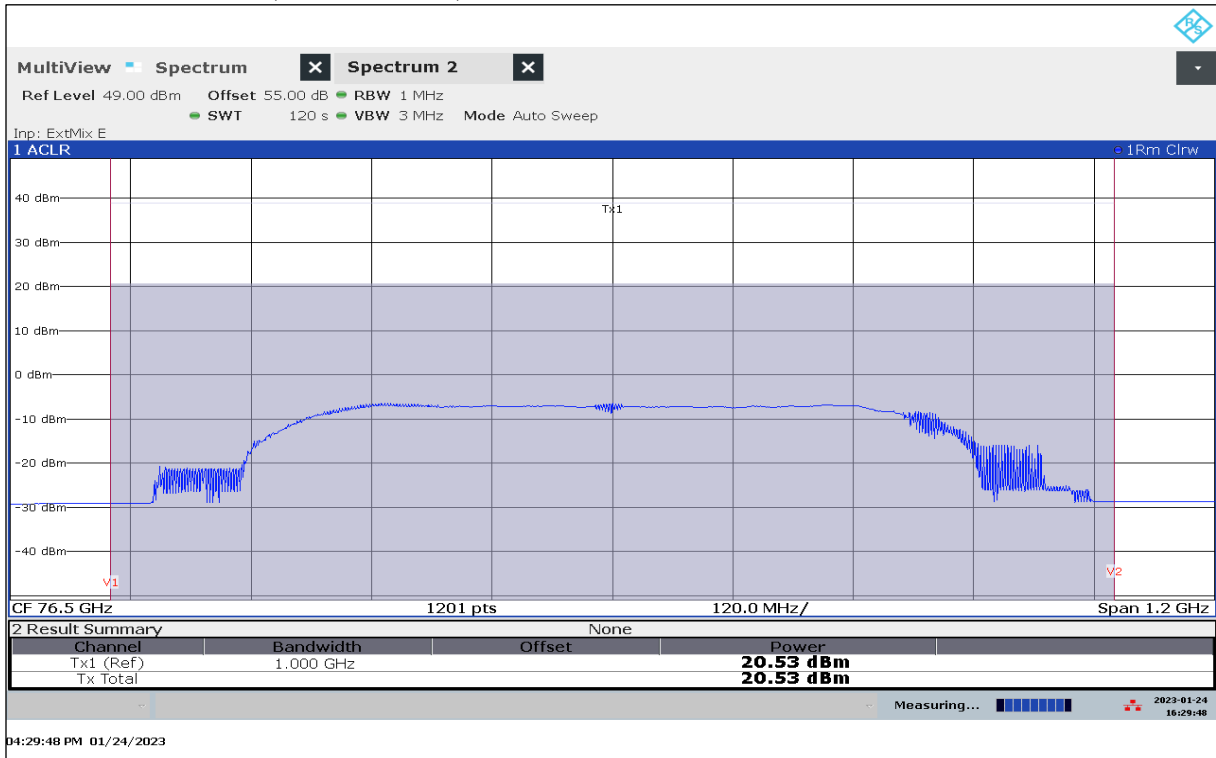

Plot 49: EIRP Mean Power (Channel Power), Mode 63, RMS detector, $T_{nom} / V_{min-max}$

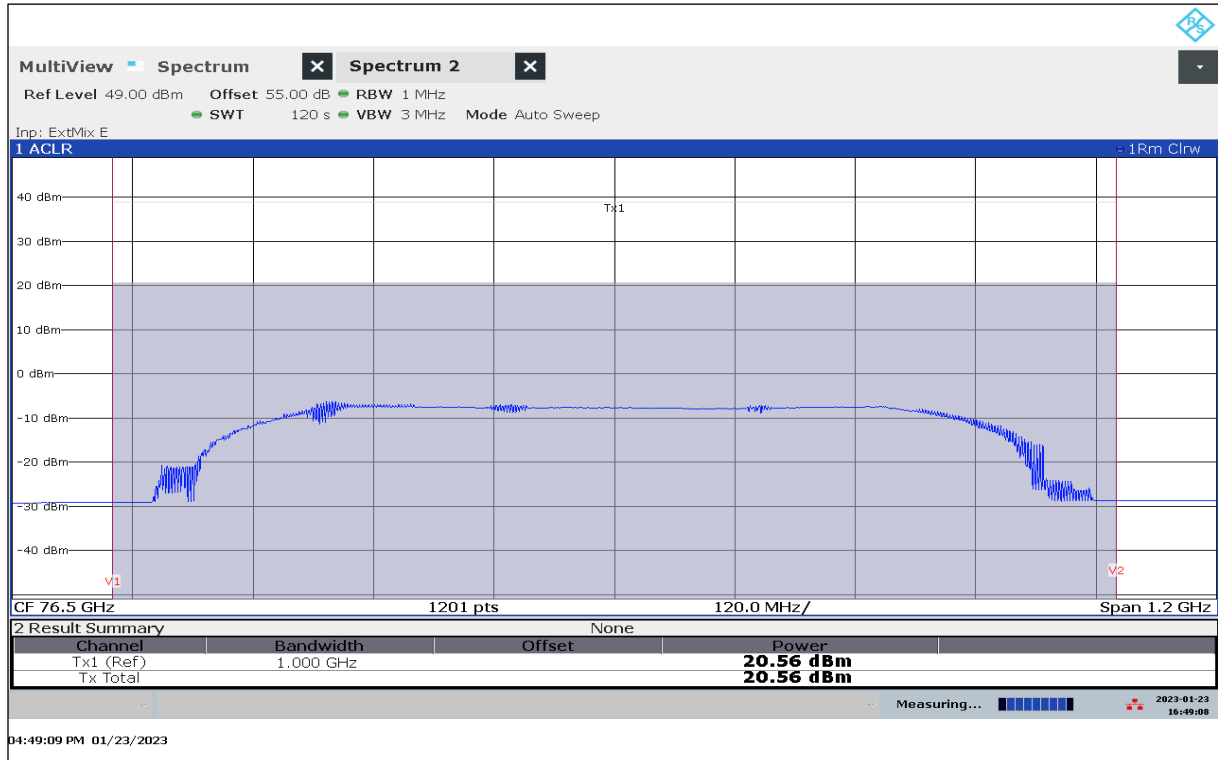

Plot 50: EIRP Mean Power (Channel Power), Mode 63, RMS detector, $T_{min} / V_{min-max}$

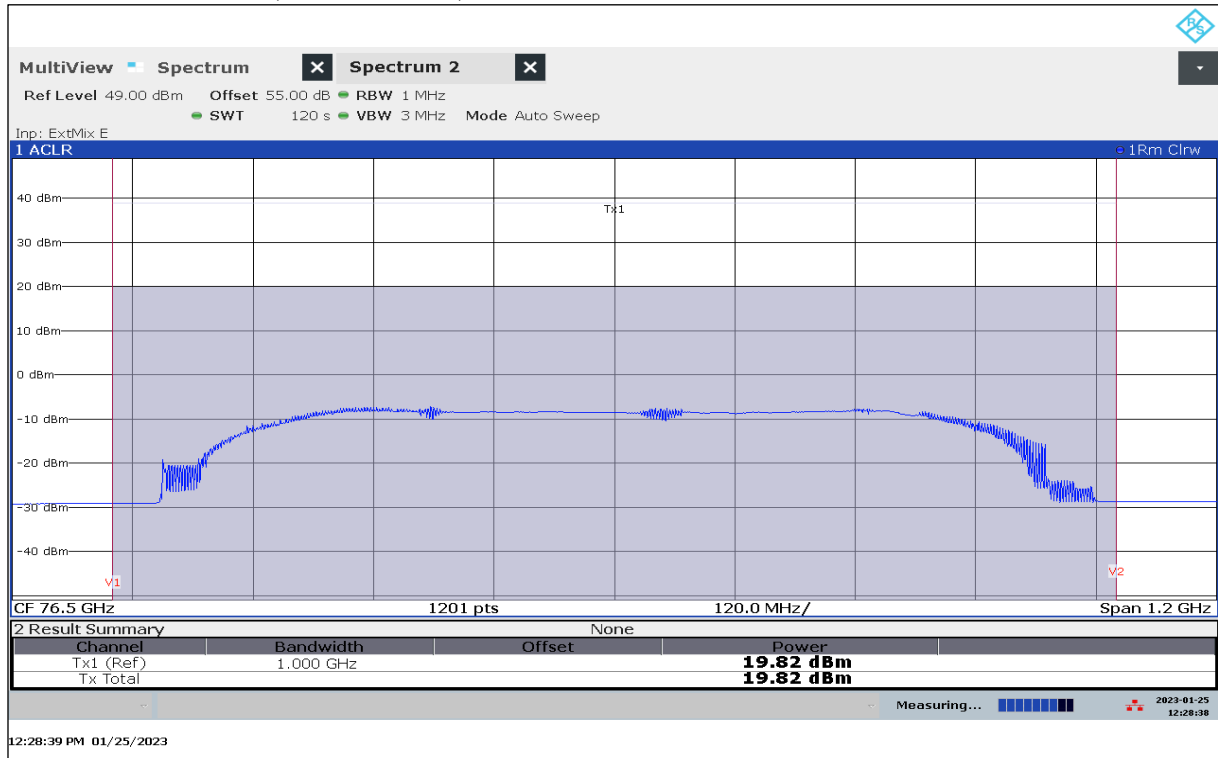

Plot 51: EIRP Mean Power (Channel Power), Mode 63, RMS detector, $T_{max} / V_{min-max}$

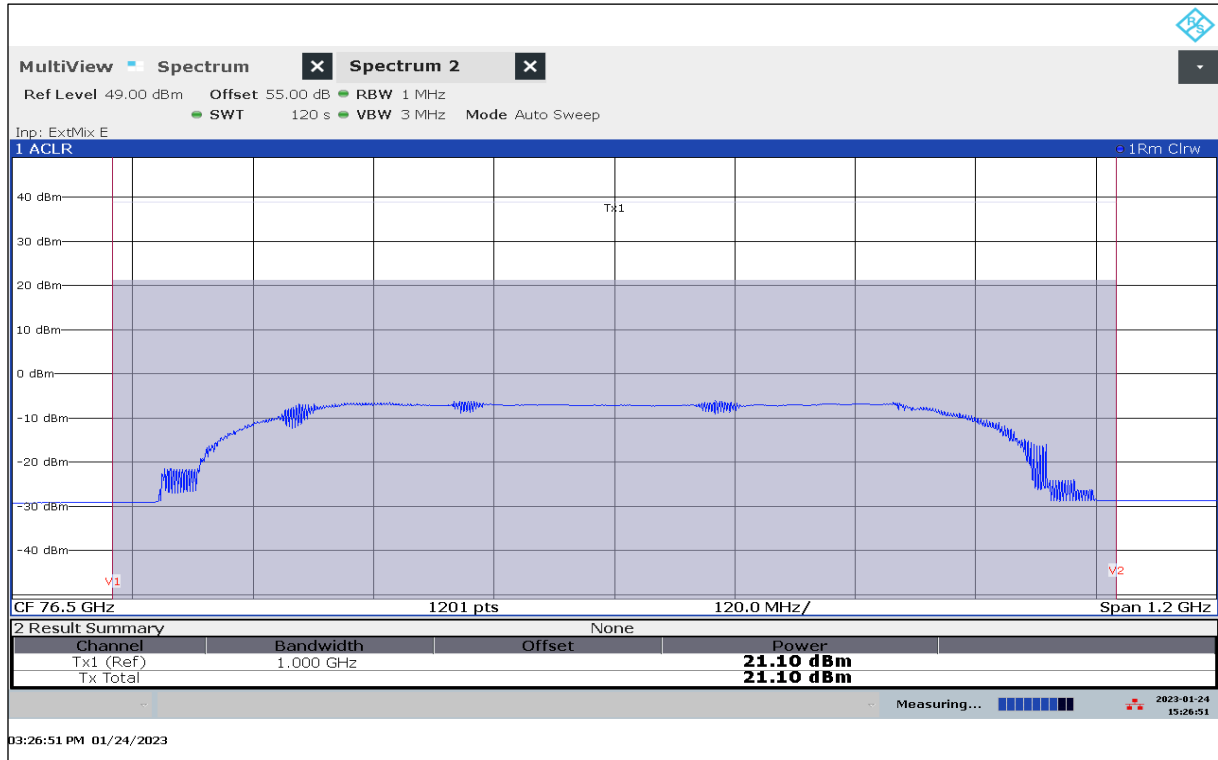

Plot 52: EIRP Mean Power (Channel Power), Mode 80, RMS detector, $T_{nom} / V_{min-max}$

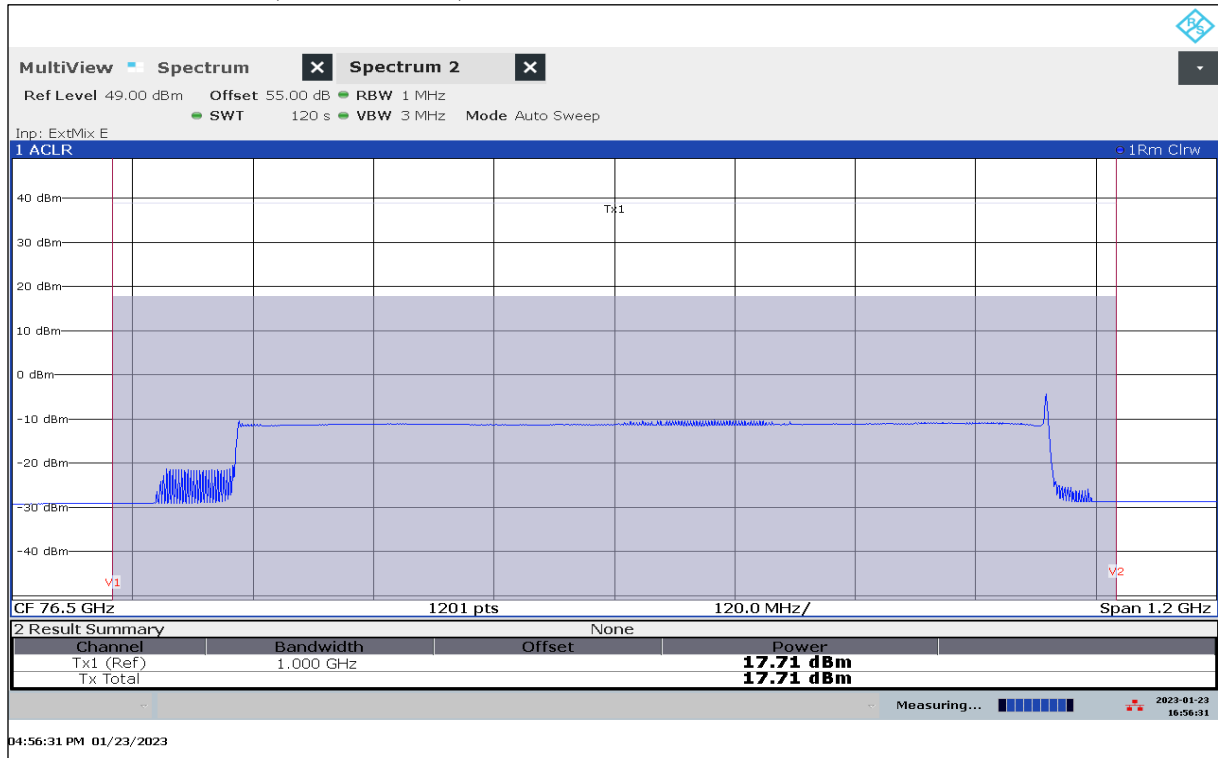

Plot 53: EIRP Mean Power (Channel Power), Mode 80, RMS detector, $T_{min} / V_{min-max}$

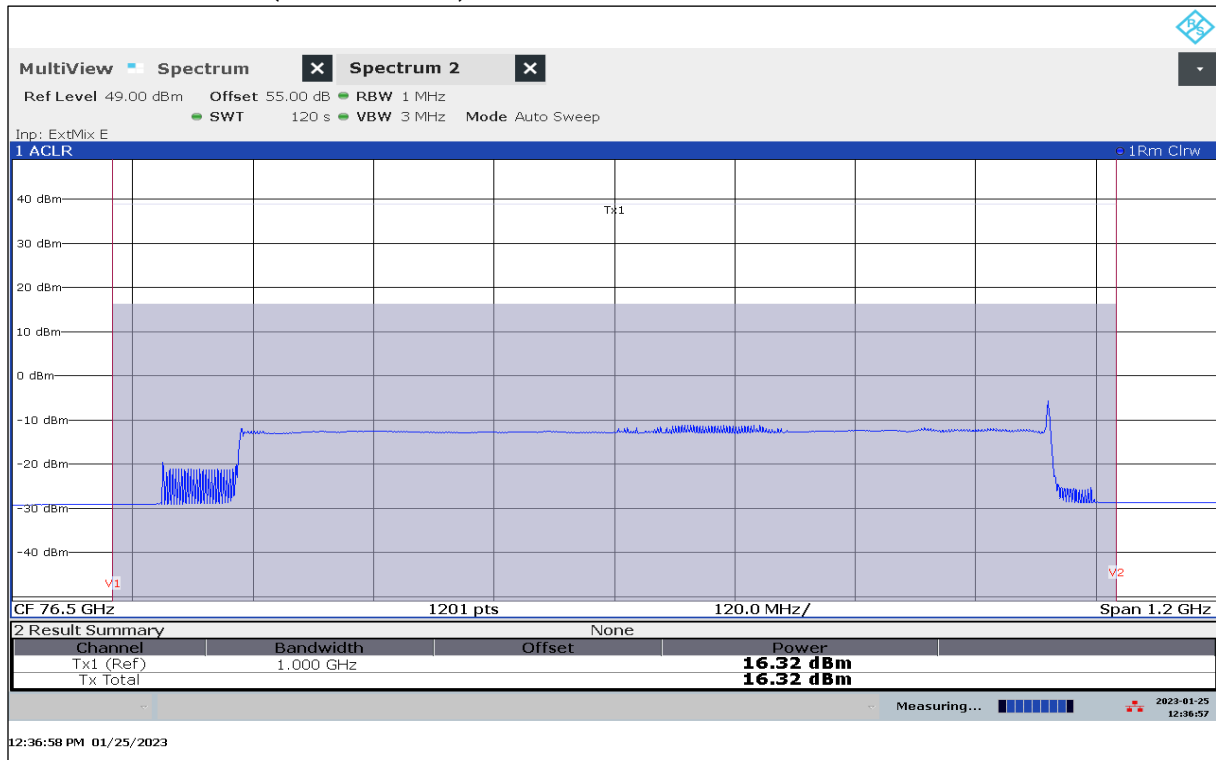

Plot 54: EIRP Mean Power (Channel Power), Mode 80, RMS detector, $T_{max} / V_{min-max}$

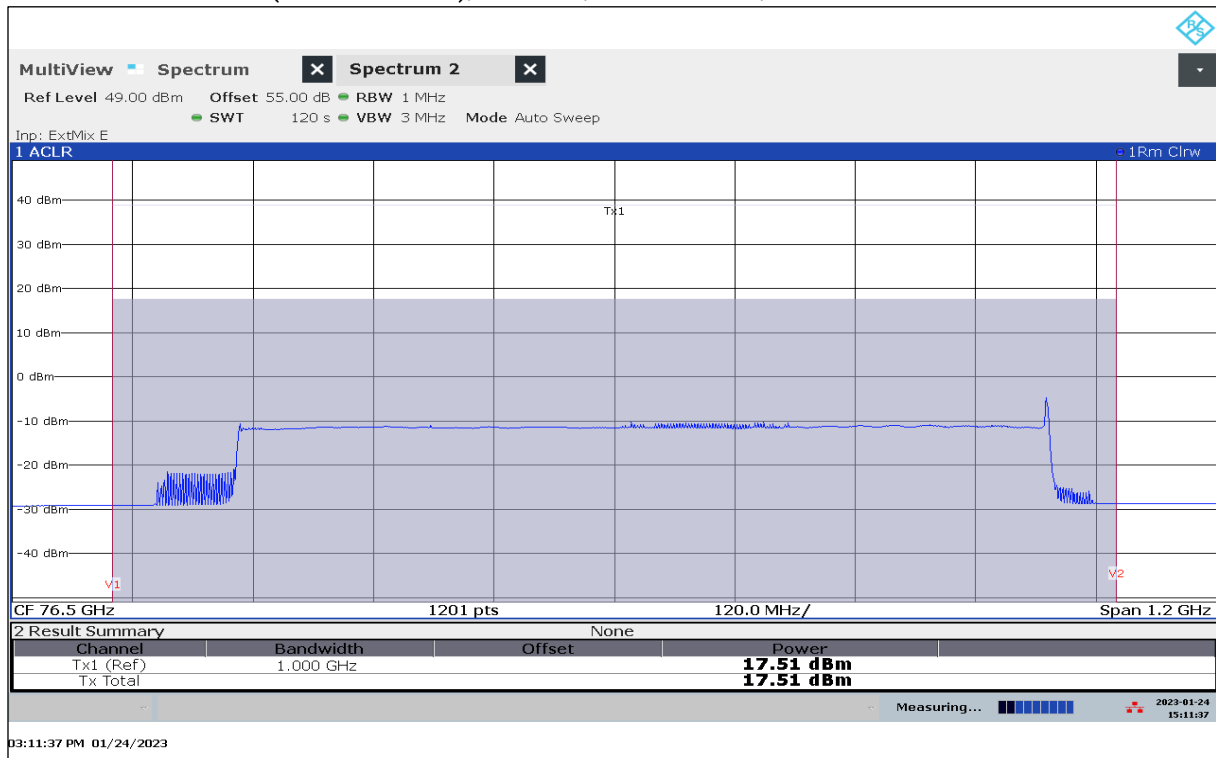

12.2 Modulation characteristics

Description:

§2.1047 (d) *Other types of equipment.* A curve or equivalent data which shows that the equipment will meet the modulation requirements of the rules under which the equipment is to be licensed.

Comments from manufacturer on modulation characteristics according to KDB 653005 3.(g):

Parameter	ARS6-A
Duty Cycle	Typical 46 %
Timing	Typical Cycle Time: 50 ms RF on 23.09 ms (256 Ramps + Monitoring)
Modulation	FM- chirps, negative Sawtooth with linear change of center frequency over sweep bandwidth or single chirps
Sweep Bandwidth	Mode dependent: 817 / 912 / 733 /829 /801 MHz
Sweep rate	Max 13 MHz/ μ s
Power	Power constant during RF on
Steepness of Ramps	Steepness varies for scans and monitoring.
Calibration	No calibration routines applied
Antenna Beam Steering (Tx)	No beam steering

12.3 Occupied bandwidth

Description:

§2.1049 The occupied bandwidth, that is the frequency bandwidth such that, below its lower and above its upper frequency limits, the mean powers radiated are each equal to 0.5 percent of the total mean power radiated by a given emission.

Limits:

FCC §95.3379 (b)

The occupied bandwidth from intentional radiators operated within the specified frequency band shall comply with the following: 76 GHz – 81 GHz

Measurement:

Parameters	
Detector:	Pos. Peak
Sweep time:	120 s
Resolution bandwidth:	1 MHz
Video bandwidth:	3 MHz
Trace-Mode:	Max Hold
Measurement distance:	2 m

Measurement results:

Modulations / Test conditions		Operating Frequency Range		
		f _L [GHz]	f _H [GHz]	OBW [MHz]
03	T _{nom} / V _{min-max}	76.048 630	76.954 483	905.9
	T _{min} / V _{min-max}	76.054 192	76.957 940	903.7
	T _{max} / V _{min-max}	76.052 817	76.955 282	902.5
09	T _{nom} / V _{min-max}	76.048 604	76.947 321	898.7
	T _{min} / V _{min-max}	76.051 458	76.950 853	899.4
	T _{max} / V _{min-max}	76.052 027	76.949 995	898.0
15	T _{nom} / V _{min-max}	76.096 105	76.877 647	781.5
	T _{min} / V _{min-max}	76.114 331	76.889 534	775.2
	T _{max} / V _{min-max}	76.113 627	76.893 320	779.7
21	T _{nom} / V _{min-max}	76.085 427	76.908 962	823.5
	T _{min} / V _{min-max}	76.087 555	76.912 799	825.2
	T _{max} / V _{min-max}	76.089 425	76.913 277	823.9
27	T _{nom} / V _{min-max}	76.049 846	76.955 928	906.1
	T _{min} / V _{min-max}	76.051 600	76.958 631	907.0
	T _{max} / V _{min-max}	76.053 668	76.959 720	906.1
39	T _{nom} / V _{min-max}	76.051 906	76.948 803	896.9
	T _{min} / V _{min-max}	76.051 752	76.953 608	901.9
	T _{max} / V _{min-max}	76.051 419	76.952 835	901.4
51	T _{nom} / V _{min-max}	76.059 193	76.922 148	863.0
	T _{min} / V _{min-max}	76.058 582	76.938 531	880.0
	T _{max} / V _{min-max}	76.062 466	76.917 078	854.6
63	T _{nom} / V _{min-max}	76.063 031	76.924 048	861.0
	T _{min} / V _{min-max}	76.061 526	76.935 265	873.7
	T _{max} / V _{min-max}	76.070 162	76.917 479	847.3
80	T _{nom} / V _{min-max}	76.054 258	76.944 667	890.4
	T _{min} / V _{min-max}	76.053 145	76.961 909	908.8
	T _{max} / V _{min-max}	76.056 452	76.945 979	889.5

Note: Voltage variation does not affect the radiated signal

Verdict: Compliant

12.4 Band edge compliance

Description:

Investigation of the emission limits at the band edge.

Limits:

FCC §95.3379 (a) (2) (i) + (ii) / ANSI C63.10-2013 / 6.10

Frequency Range [GHz]	Measurement distance	Power Density
40 – 76 and 81 – 200	3.0 m	600 pW/cm ² → -1.7 dBm

Limits:

FCC §95.3367 (a) (b)

Frequency Range [GHz]	Power Density
76 - 81	50 dBm/MHz (e.i.r.p)

Measurement:

Parameters	
Detector:	RMS
Sweep time:	See plots
Resolution bandwidth:	1 MHz
Video bandwidth:	3 MHz
Trace-Mode:	Max Hold

Measurement results:

- Results are part of chapter 12.5

Verdict: Compliant

12.5 Field strength of spurious emissions

Description:

The power density of any emissions outside the 76-81 GHz band shall consist solely of spurious emissions and shall not exceed the following:

Limits:

FCC		
CFR Part 95.3379 (a) (1) / CFR Part 95.3379 (a) (3)		
Radiated Spurious Emissions		
Emissions radiated outside of the specified frequency bands, except for harmonics, shall be attenuated by at least 50 dB below the level of the fundamental or to the general radiated emission limits in § 15.209, whichever is the lesser attenuation.		
Frequency [MHz]	Field Strength [dB μ V/m]	Measurement distance
0.009 – 0.490	2400/F[kHz]	300
0.490 – 1.705	24000/F[kHz]	30
1.705 – 30.0	30	30
30 – 88	30.0	10
88 – 216	33.5	10
216 – 960	36.0	10
960 – 40 000	54.0	3

Limits:

FCC §95.3379 (a) (2) (i) + (ii)

Frequency Range [GHz]	Measurement distance	Power Density
40 – 200	3.0 m	600 pW/cm ² → -1.7 dBm
200 – 231	3.0 m	1000 pW/cm ² → +0.5 dBm

Measurement:

Measurement parameter	
Detector:	Quasi Peak / Pos-Peak / LinAV / RMS
Resolution bandwidth:	F < 1 GHz: 100 kHz F > 1 GHz: 1 MHz
Video bandwidth:	F < 1 GHz: 300 kHz F > 1 GHz: 3 MHz
Trace-Mode:	Max Hold

Measurement:

Measurement parameter	
Detector:	Quasi Peak / Pos-Peak / LinAV / RMS
Resolution bandwidth:	F < 1 GHz: 100 kHz F > 1 GHz: 1 MHz
Video bandwidth:	F < 1 GHz: 300 kHz F > 1 GHz: 3 MHz
Trace-Mode:	Max Hold

Measurement results:

Frequency [GHz]	Detector	Bandwidth [MHz]	Level	Limit	Margin [dB]
-/-	-/-	-/-	-/-	-/-	-/-
No critical spurious emission levels					

Verdict: Compliant

Plot 55: 9 kHz – 30 MHz, Magnetic antenna, valid for specified modes

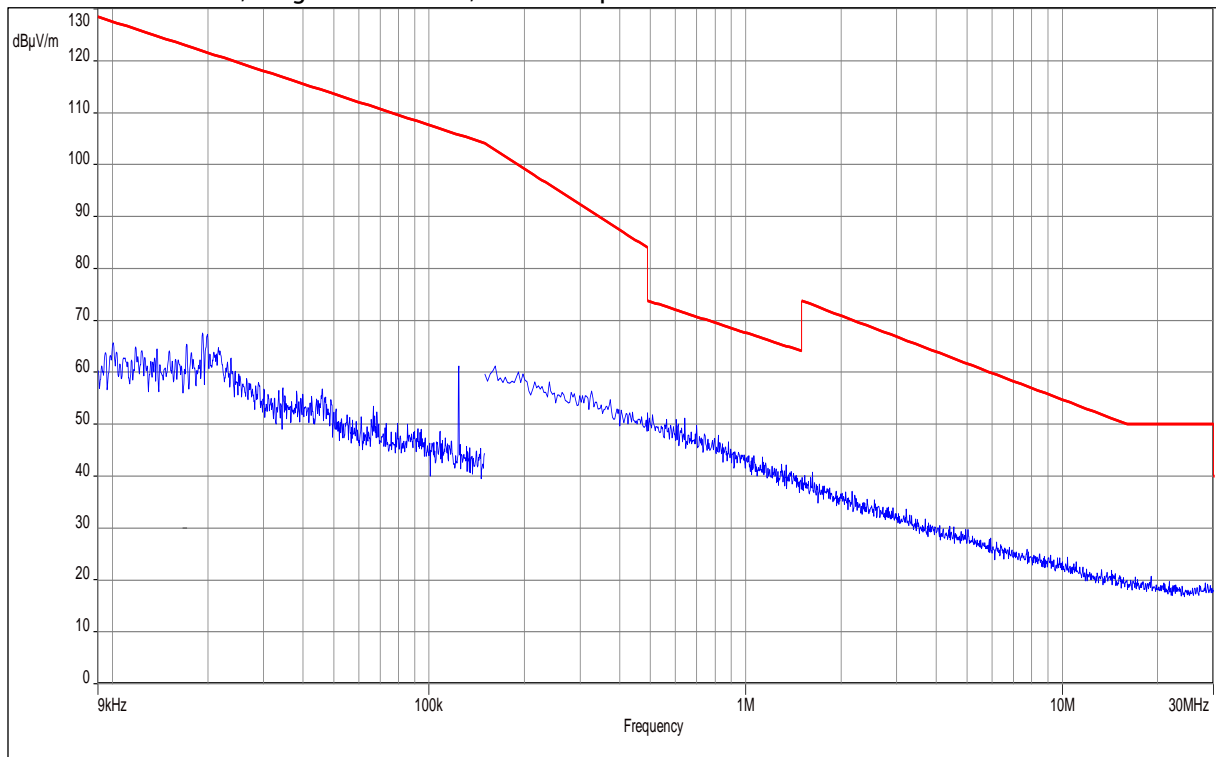

Plot 56: 30 MHz – 1 GHz, valid for specified modes, antenna vertical / horizontal

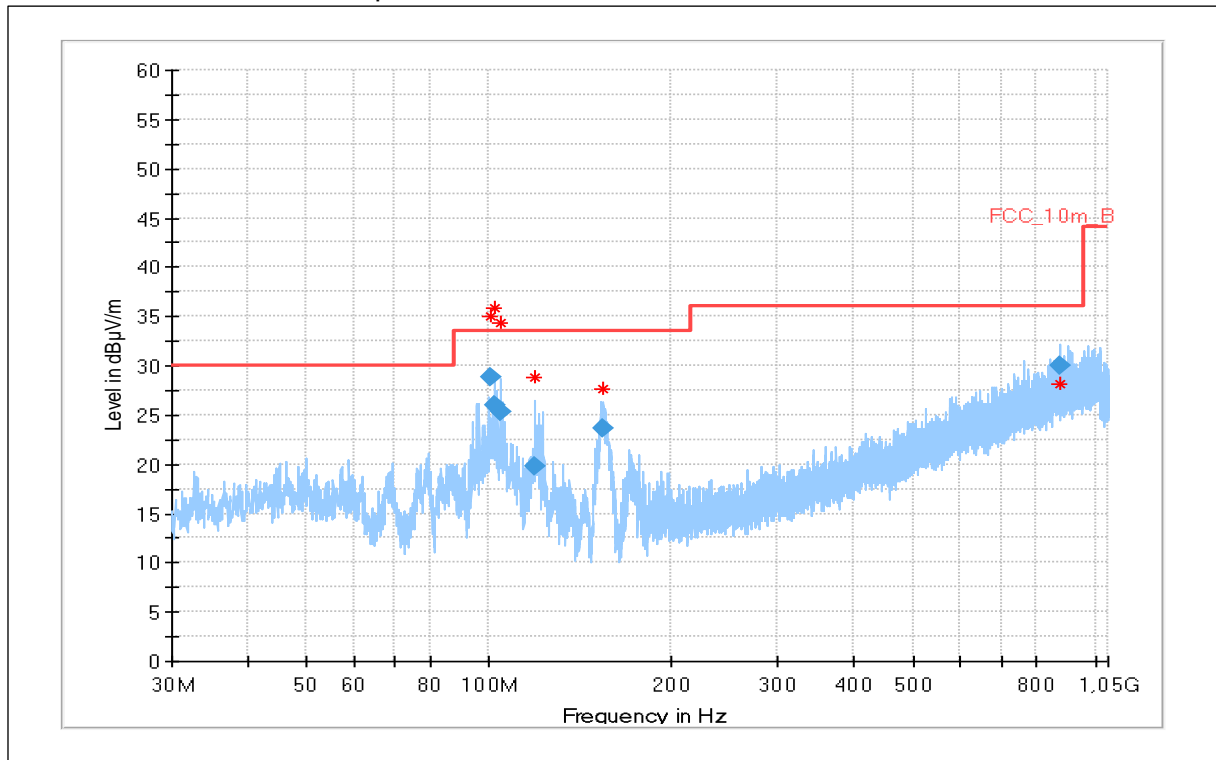

Frequency (MHz)	QuasiPeak (dBµV/m)	Limit (dBµV/m)	Margin (dB)	Meas. Time (ms)	Bandwidth (kHz)	Height (cm)	Pol	Azimuth (deg)	Corr. (dB/m)
100.500	28.79	33.5	4.7	1000	120.0	151.0	V	-23	14
101.934	25.97	33.5	7.5	1000	120.0	102.0	V	-36	14
104.706	25.28	33.5	8.2	1000	120.0	147.0	V	-8	14
118.930	19.85	33.5	13.7	1000	120.0	195.0	V	53	12
154.584	23.64	33.5	9.9	1000	120.0	98.0	V	-36	10
875.961	29.95	36.0	6.1	1000	120.0	174.0	H	-37	25

Plot 57: 1 GHz – 18 GHz, valid for specified modes, antenna vertical / horizontal

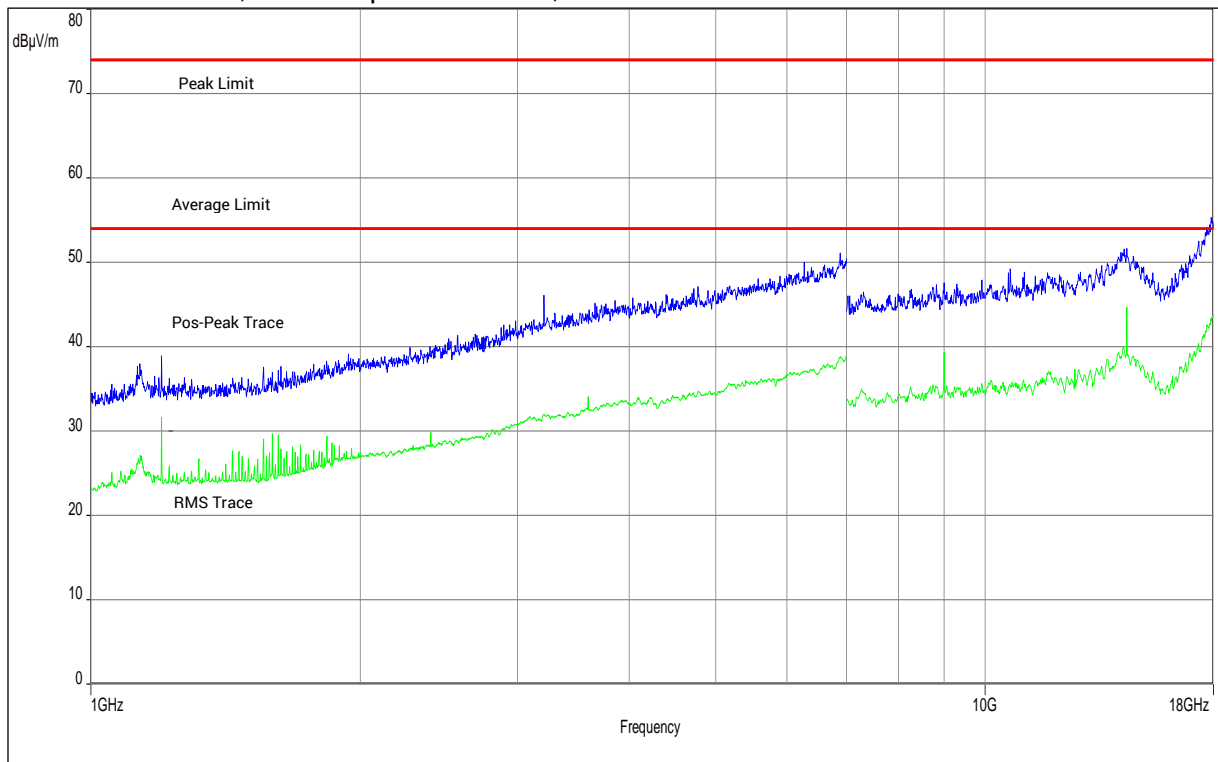

Plot 58: 18 GHz – 40 GHz, valid for specified modes, antenna vertical / horizontal (PEAK detector)

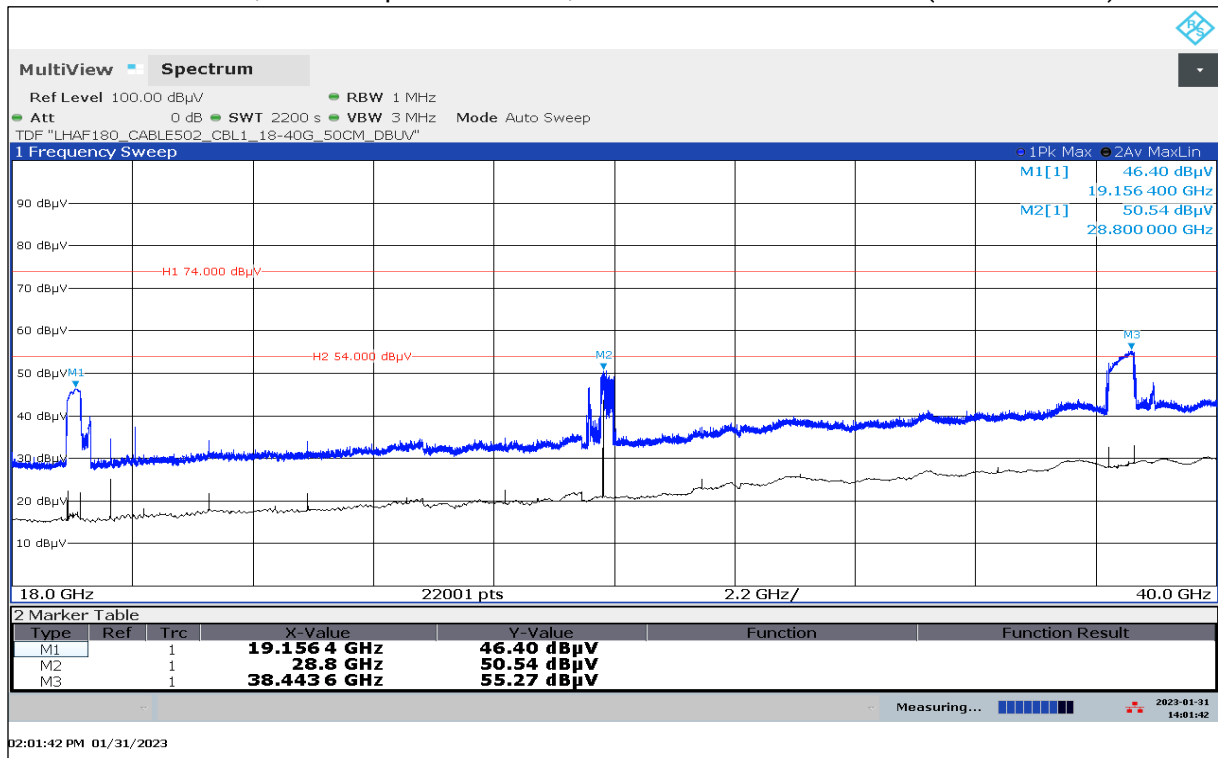

Plot 59: 18 GHz – 40 GHz, valid for specified modes, antenna vertical / horizontal (Average detector)

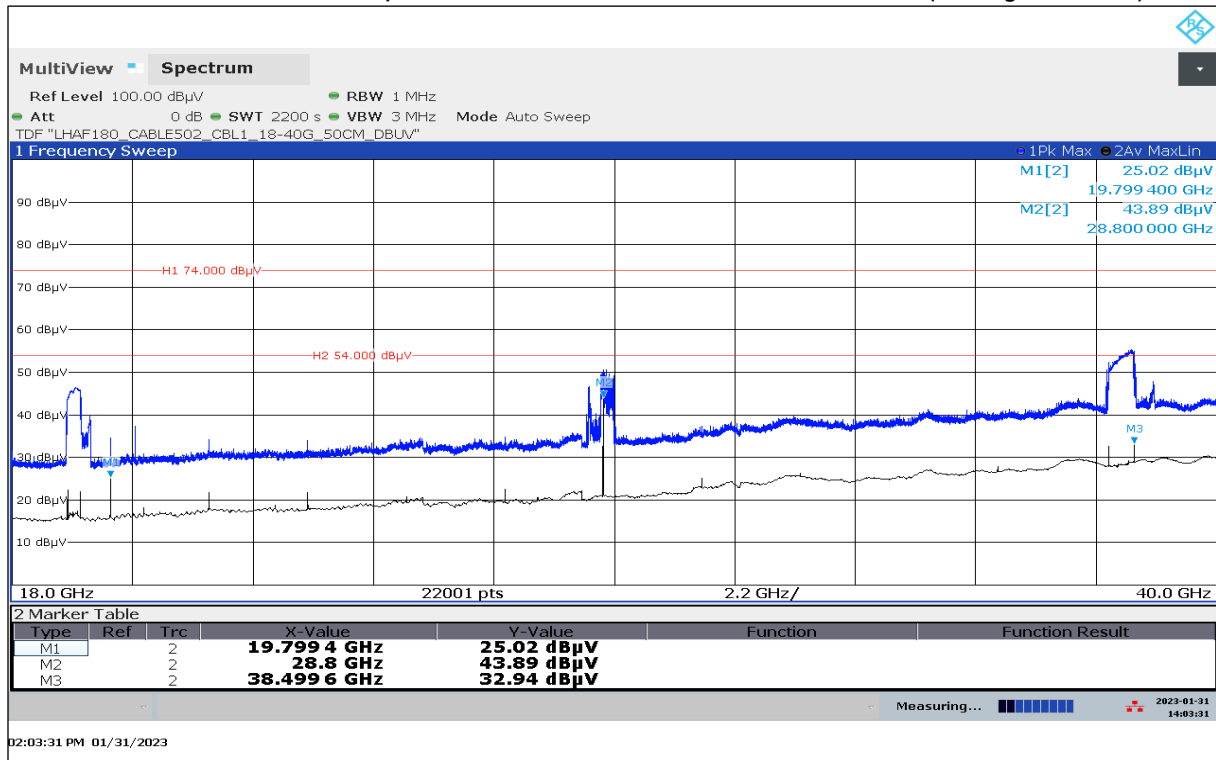

Plot 60: 28.8 GHz, valid for specified modes, antenna vertical / horizontal

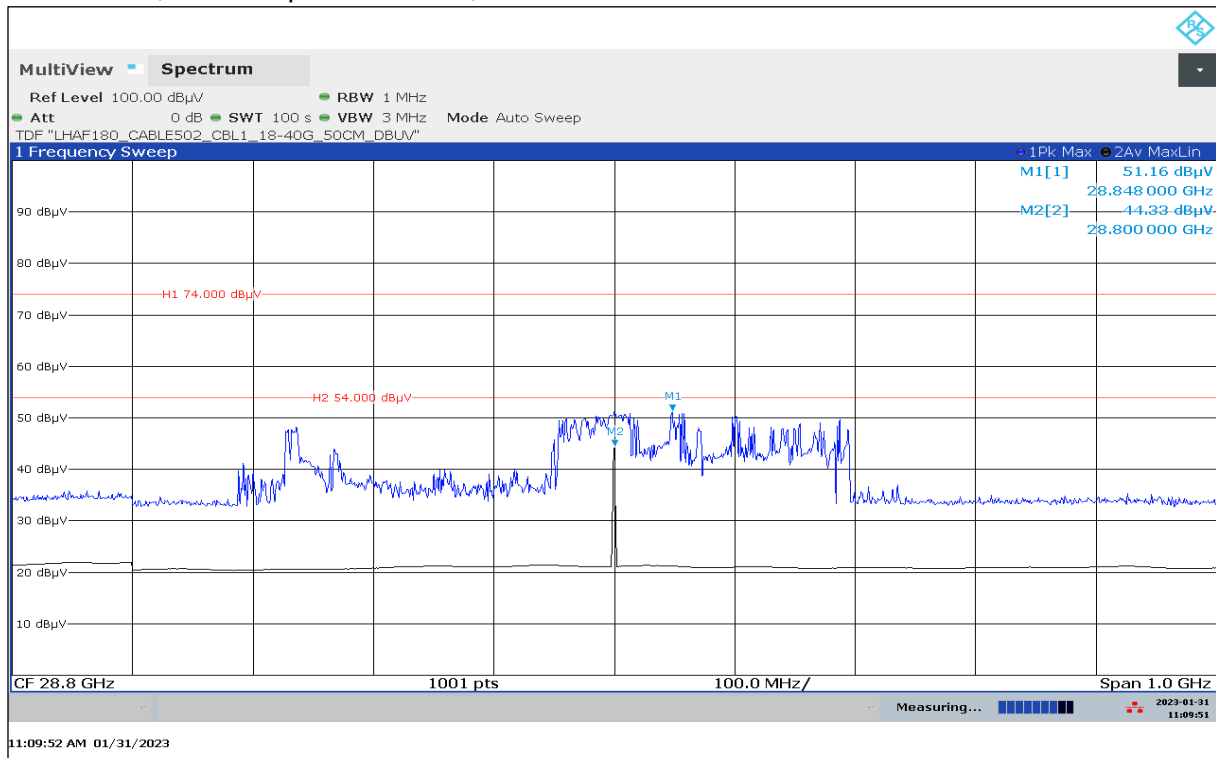

Peak Value: 51.16 dBµV/m (Limit 74 dBµV/m) / Average 44.33 dBµV/m (Limit 54 dBµV/m)

Plot 61: 38 GHz, valid for specified modes, antenna vertical / horizontal

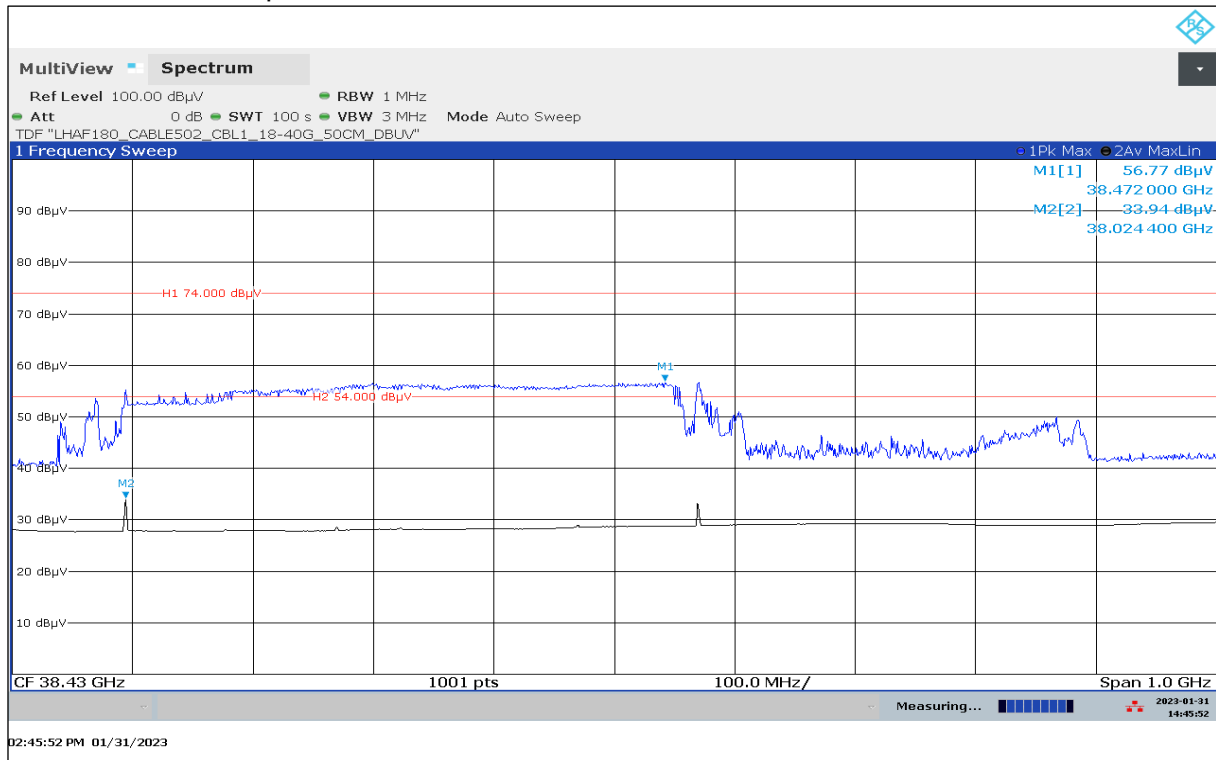

Peak Value: 56.77 dBµV/m (Limit 74 dBµV/m) / Average 33.94 dBµV/m (Limit 54 dBµV/m)

Plot 62: 40 GHz – 60 GHz, valid for specified modes, antenna vertical / horizontal

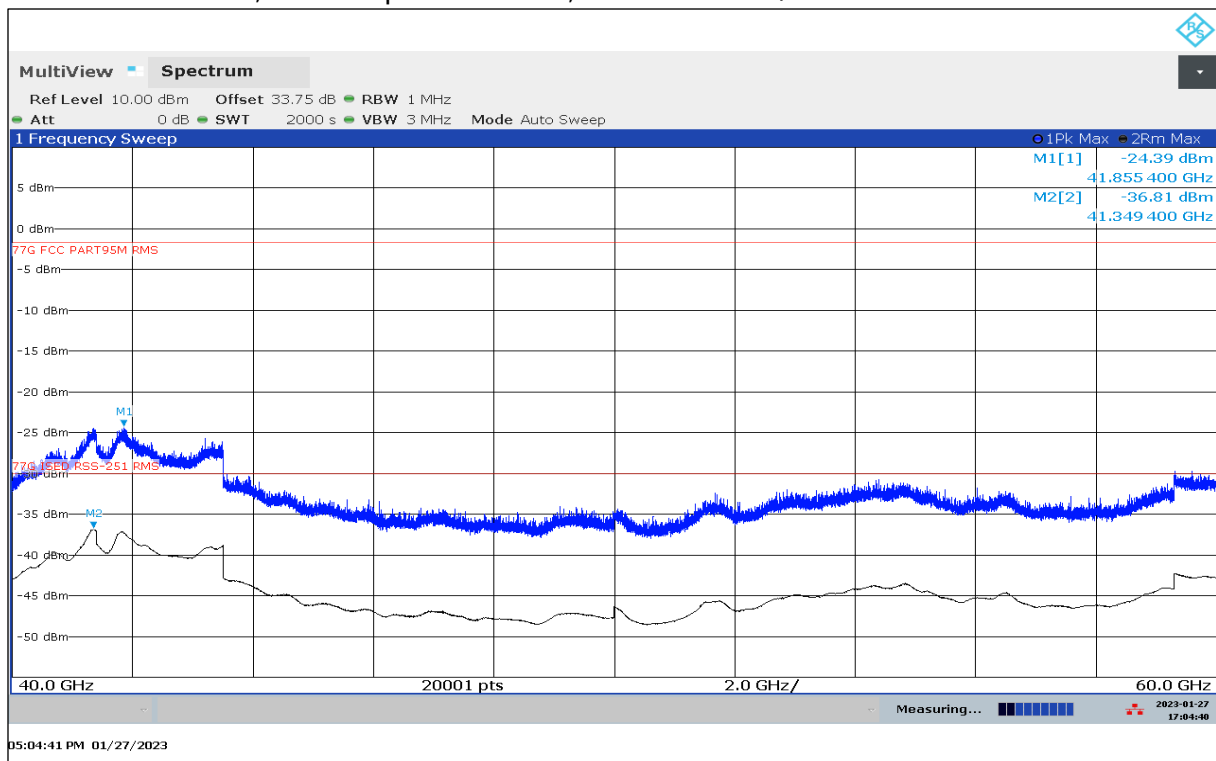

Marker 1 (Peak value) is just informative, Marker 2 shows the right value with a RMS detector

Plot 63: 60 GHz – 72 GHz, valid for specified modes, antenna vertical / horizontal

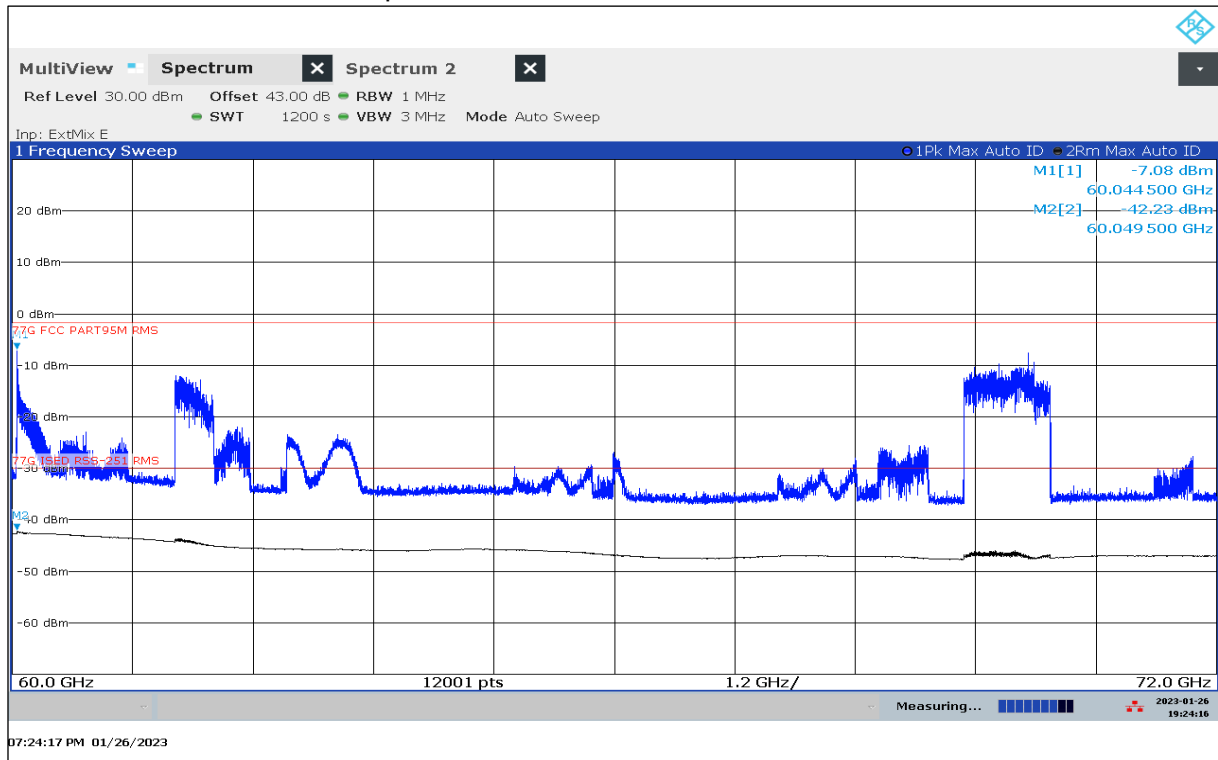

Marker 1 (Peak value) is just informative, Marker 2 shows the right value with a RMS detector

Plot 64: 72 GHz – 81 GHz, Mode 03, antenna vertical / horizontal

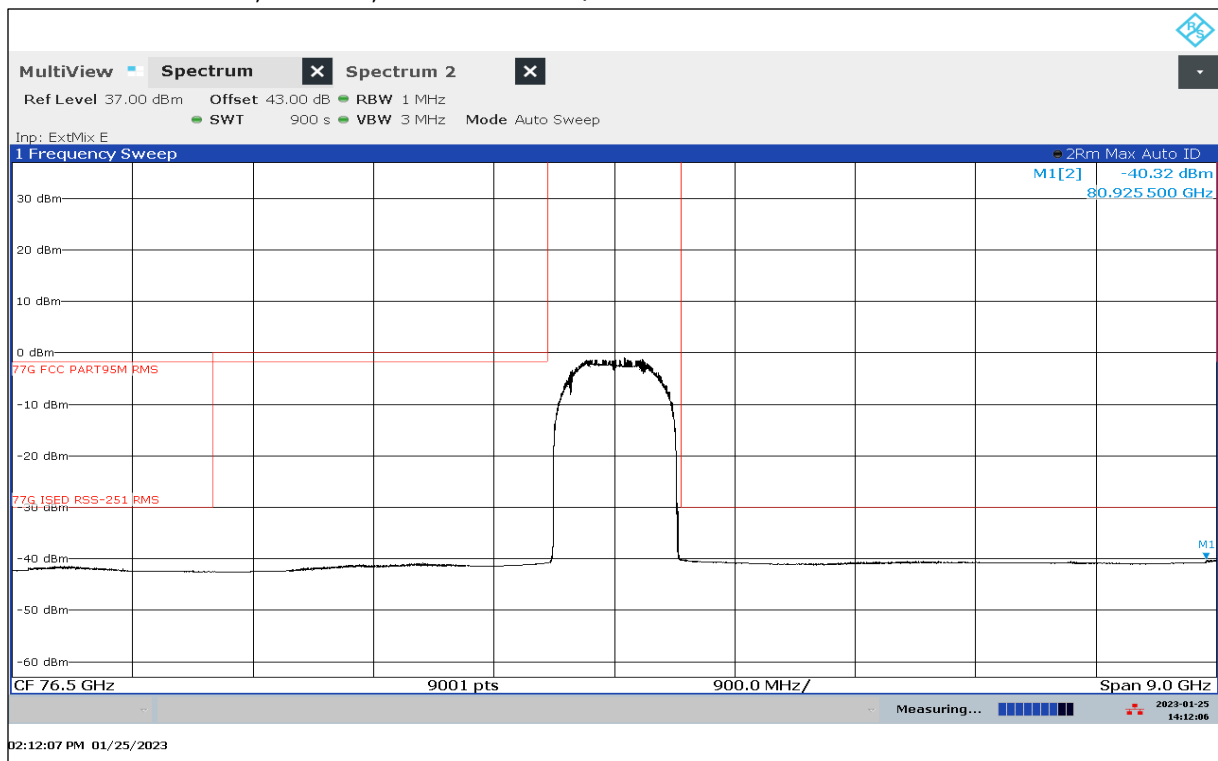

Plot 65: 72 GHz – 81 GHz, Mode 09, antenna vertical / horizontal

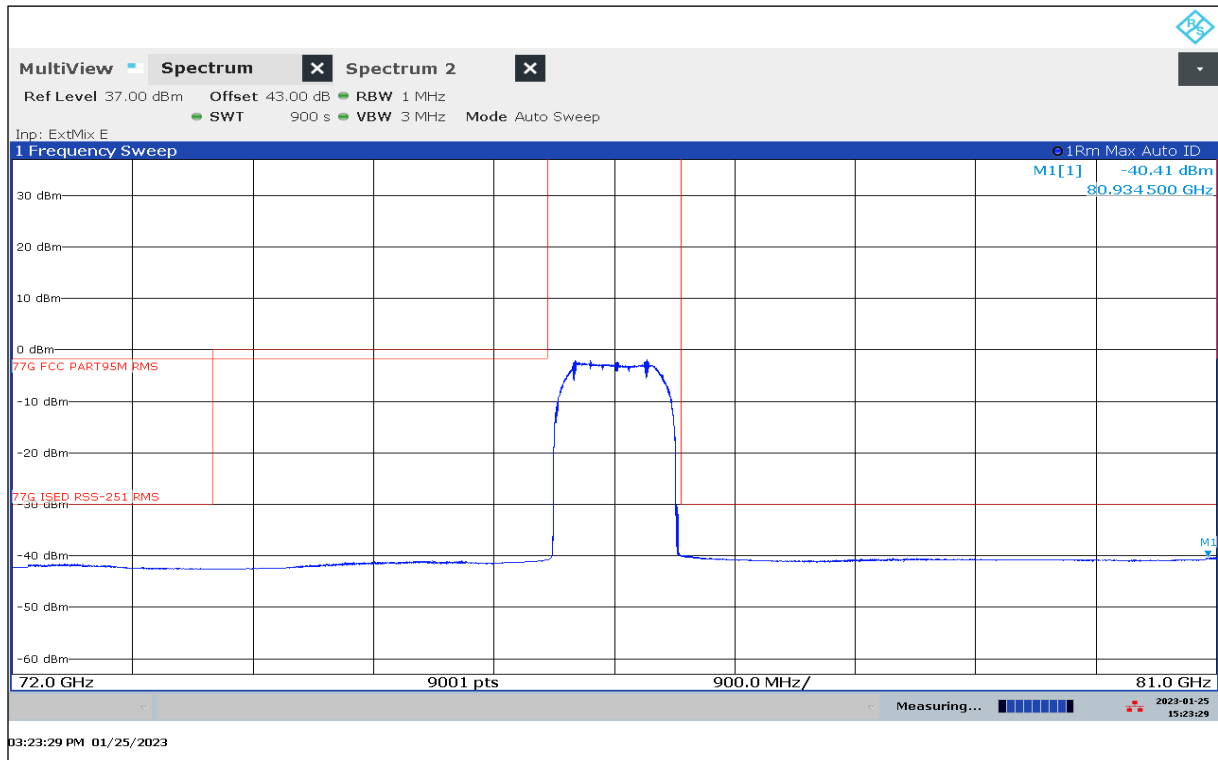

Plot 66: 72 GHz – 81 GHz, Mode 15, antenna vertical / horizontal

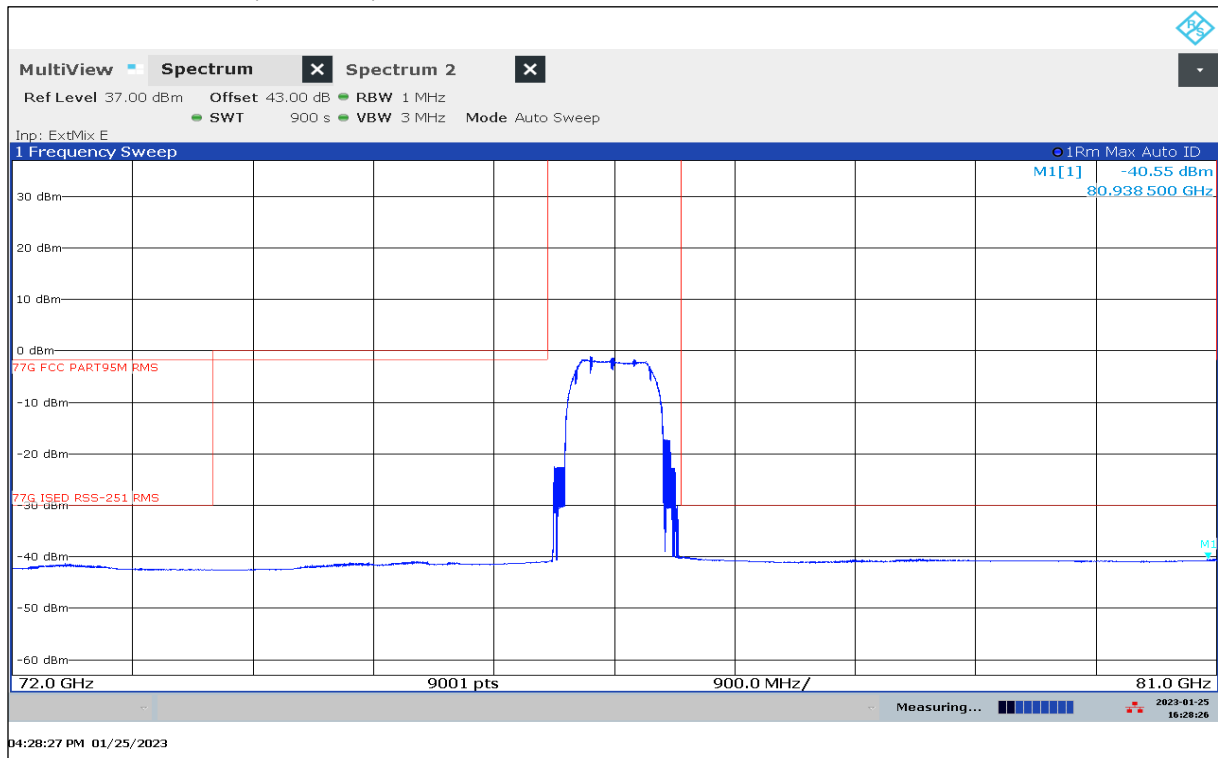

Plot 67: 72 GHz – 81 GHz, Mode 21, antenna vertical / horizontal

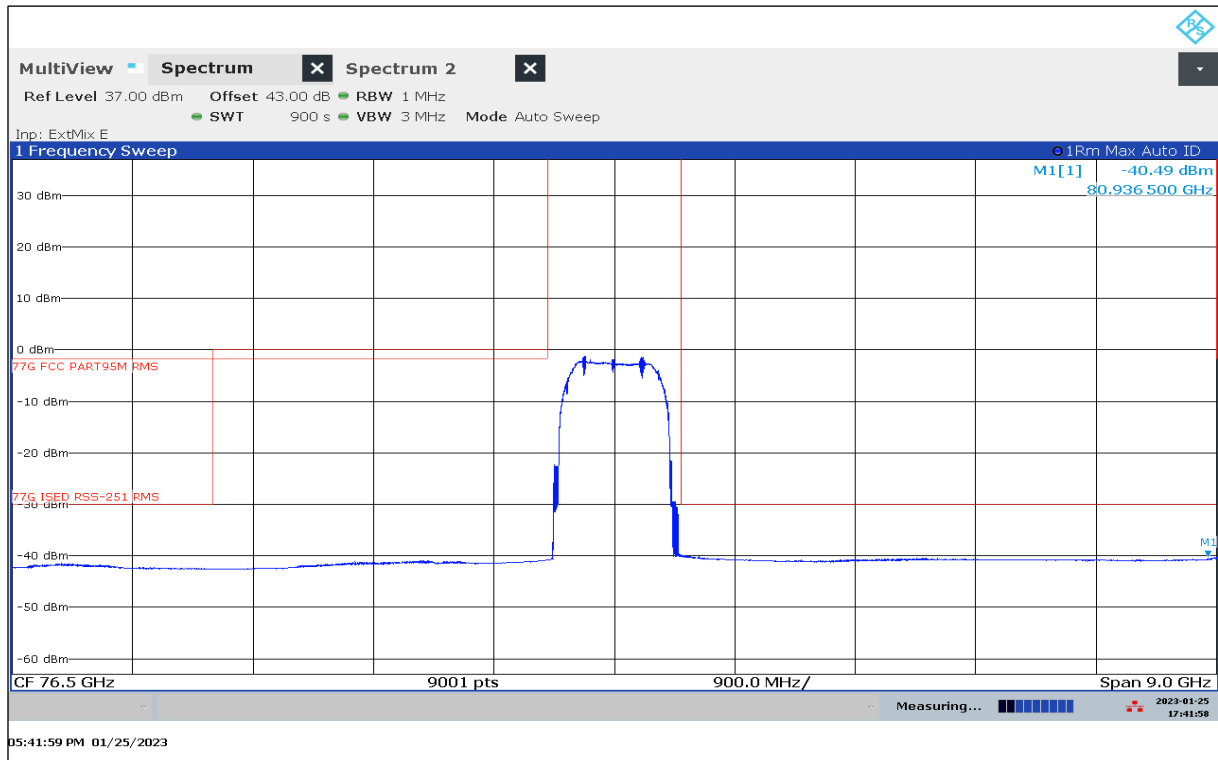

Plot 68: 72 GHz – 81 GHz, Mode 27, antenna vertical / horizontal

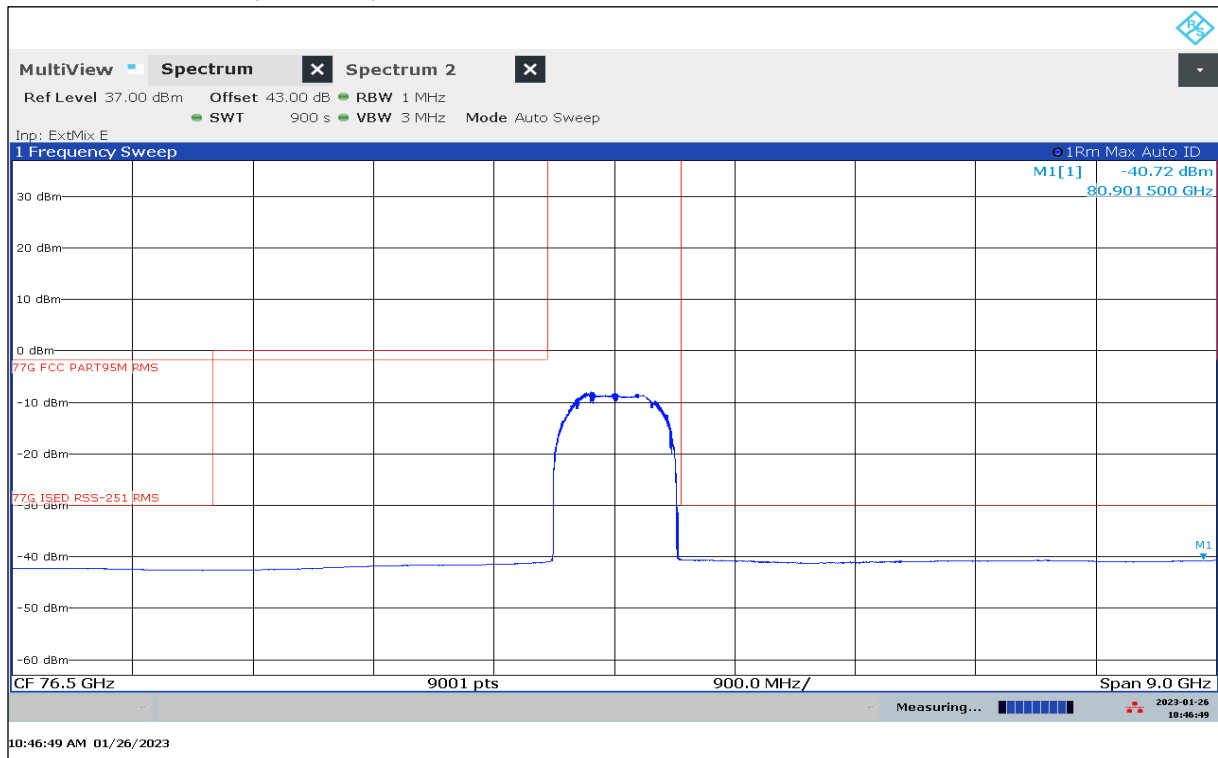

Plot 69: 72 GHz – 81 GHz, Mode 39, antenna vertical / horizontal

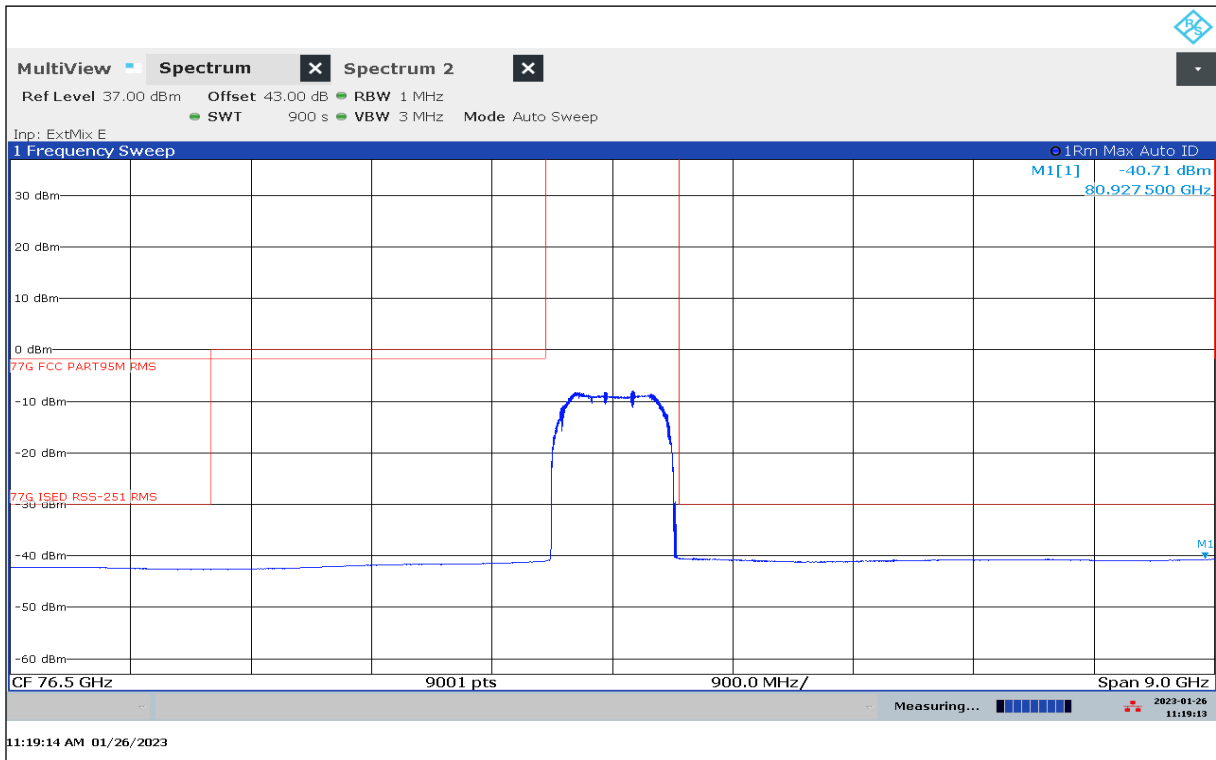

Plot 70: 72 GHz – 81 GHz, Mode 51, antenna vertical / horizontal

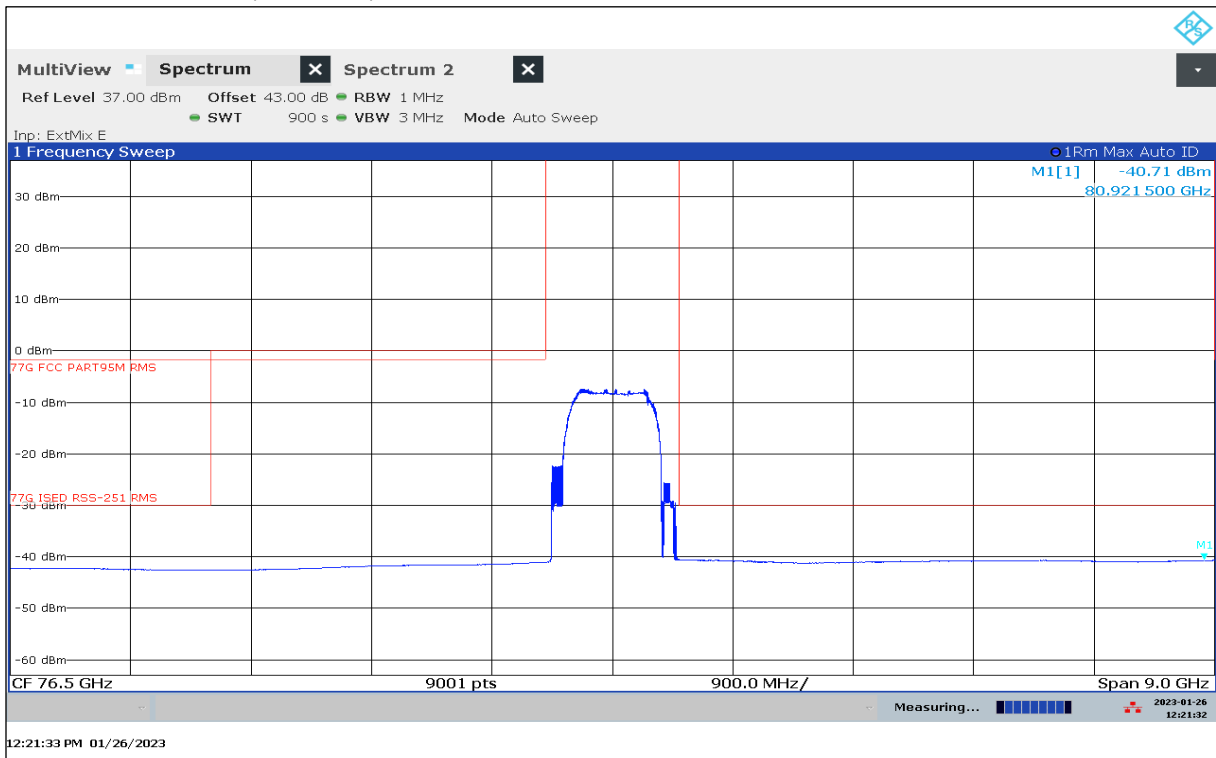

Plot 71: 72 GHz – 81 GHz, Mode 63, antenna vertical / horizontal



Plot 72: 72 GHz – 81 GHz, Mode 80, antenna vertical / horizontal

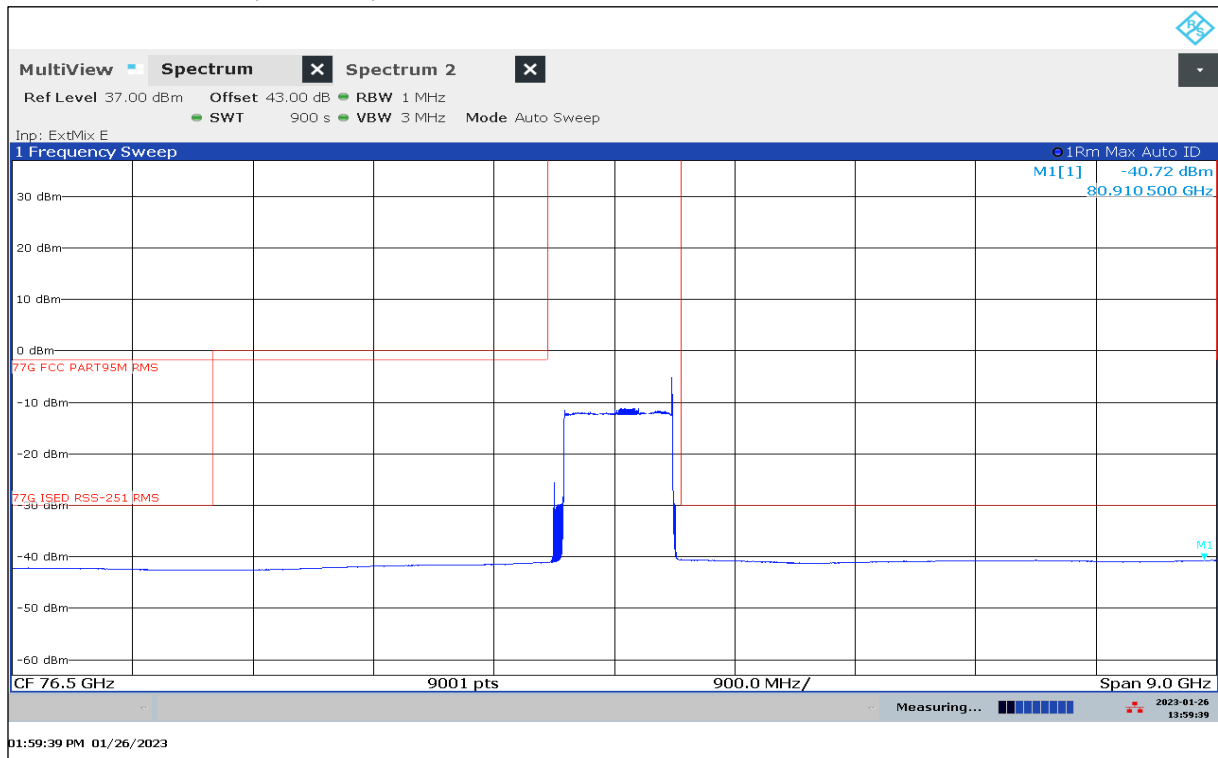

Plot 73: 81 GHz – 90 GHz, valid for specified modes, antenna vertical / horizontal

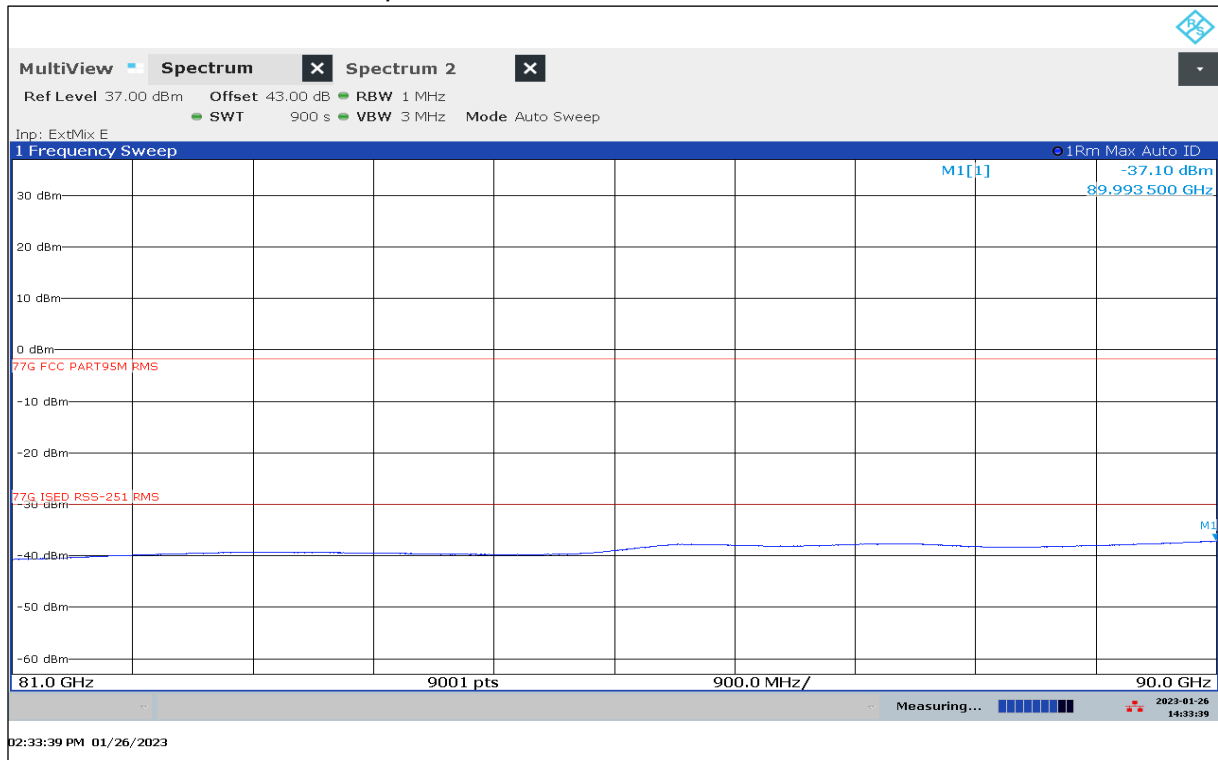

Plot 74: 90 GHz – 140 GHz, valid for specified modes, antenna vertical / horizontal

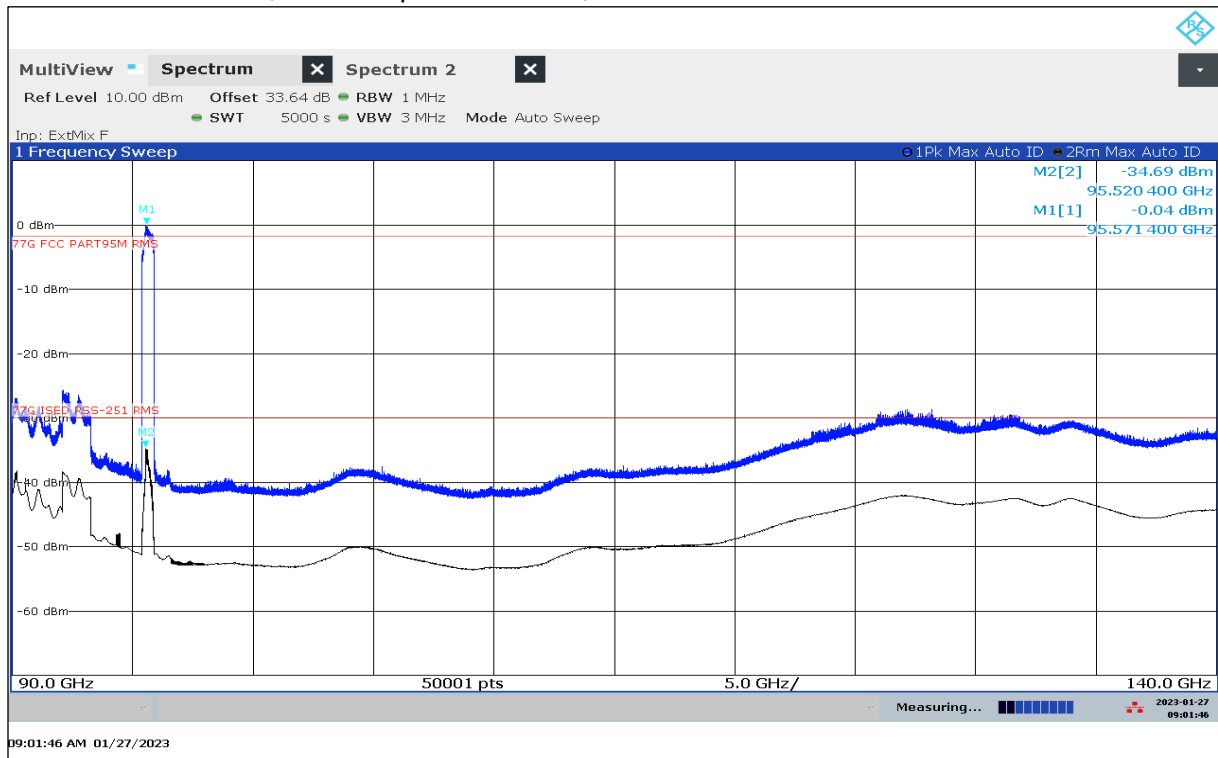

Marker 1 (Peak value only informative) and Marker 2 show mixer products produced by harmonic mixer

Plot 75: 140 GHz – 220 GHz, valid for specified modes, antenna vertical / horizontal

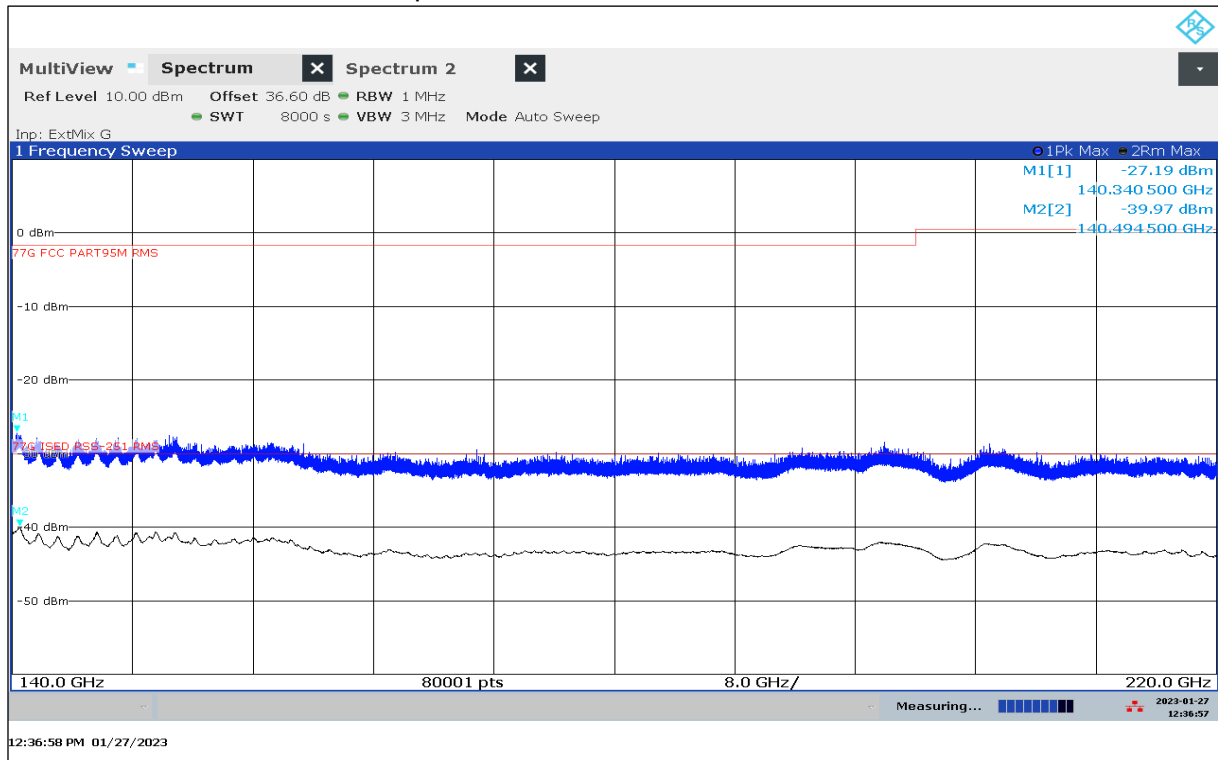

Marker 1 (Peak value) is just informative, Marker 2 shows the right value with a RMS detector

Plot 76: 220 GHz – 231 GHz, valid for specified modes, antenna vertical / horizontal

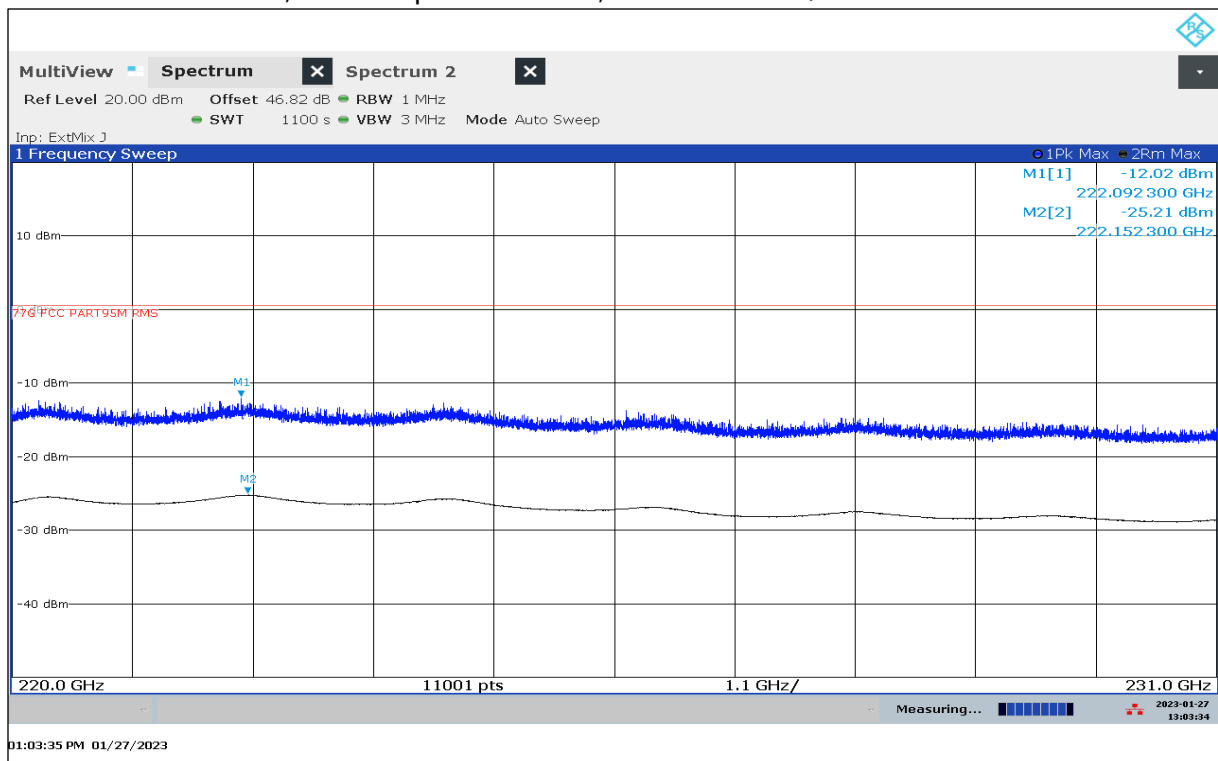

Marker 1 (Peak value) is just informative, Marker 2 shows the right value with a RMS detector

12.6 Frequency stability

Description:

§95.3379 (b) Fundamental emissions must be contained within the frequency bands specified in this section during all conditions of operation. Equipment is presumed to operate over the temperature range -20 to +50 degrees Celsius with an input voltage variation of 85% to 115% of rated input voltage, unless justification is presented to demonstrate otherwise.

Limits:

FCC §95.3379 (b)

The occupied bandwidth from intentional radiators operated within the specified frequency band shall comply with the following: 76 GHz – 81 GHz

Measurement results:

Temperature variation

Mode	Temperature in °C	f _L in GHz	f _H in GHz	Bandwidth [MHz]
Mode 09 (Worst case)	-40 °C / V _{nom}	76.051 458	76.950 853	899.4
	-20 °C / V _{nom}	76.050 028	76.948 152	898.1
	-10 °C / V _{nom}	76.050 894	76.948 567	897.7
	0 °C / V _{nom}	76.051 817	76.947 764	896.0
	10 °C / V _{nom}	76.051 126	76.948 694	897.6
	20 °C / V _{nom}	76.048 604	76.947 321	898.7
	30 °C / V _{nom}	76.050 871	76.950 296	899.4
	40 °C / V _{nom}	76.052 255	76.951 671	899.4
	50 °C / V _{nom}	76.049 861	76.948 815	899.0
	85 °C / V _{nom}	76.052 731	76.949 596	896.9

Voltage variation

Voltage variation of rated input voltage	f _L in GHz	f _H in GHz
< 85 % of U	Voltage variation does not affect the radiated signal	
> 115 % of U		

Note:

- The EUT is measured in the temperature range from -20°C to 50°C specified by §95.3379 (b)
- If the customer declared a wider temperature range, the customer take care about the proper functionality of the EUT.

Verdict: Compliant

Plot 77: Mode 09, OBW, -40 °C / V_{min-max}

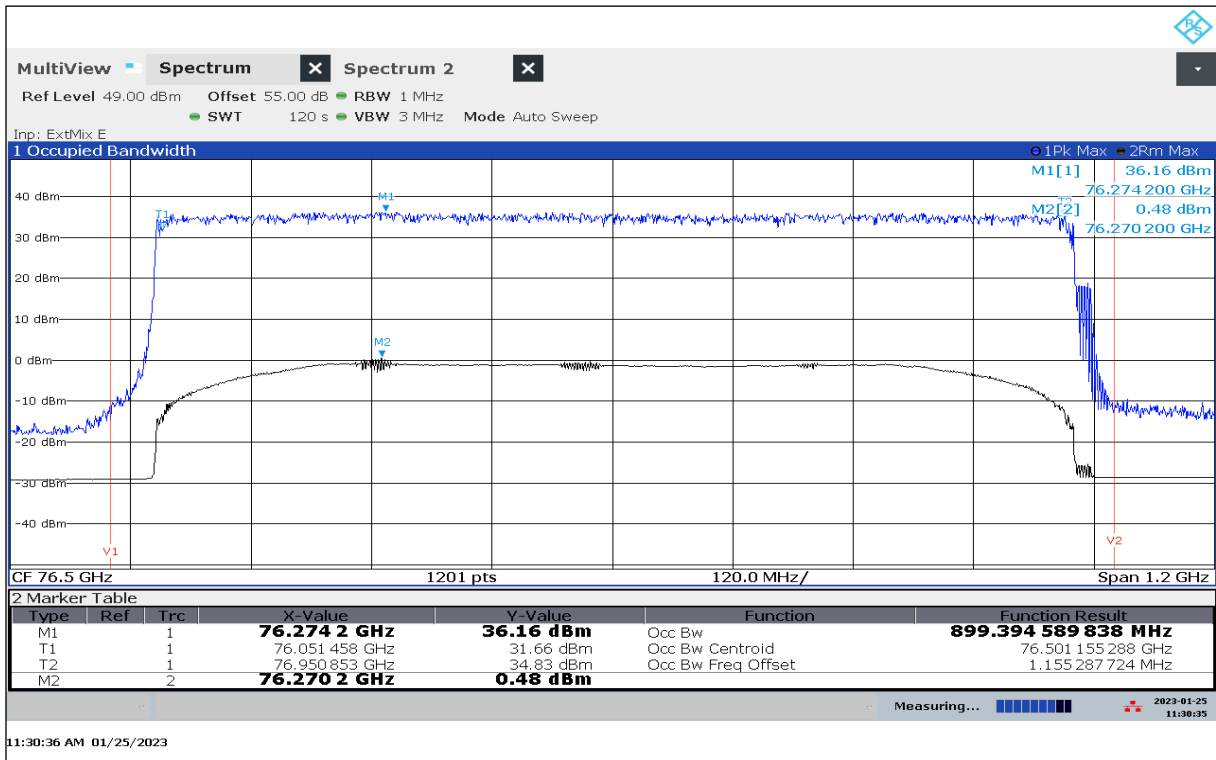

Plot 78: Mode 09, OBW, -20 °C / V_{min-max}

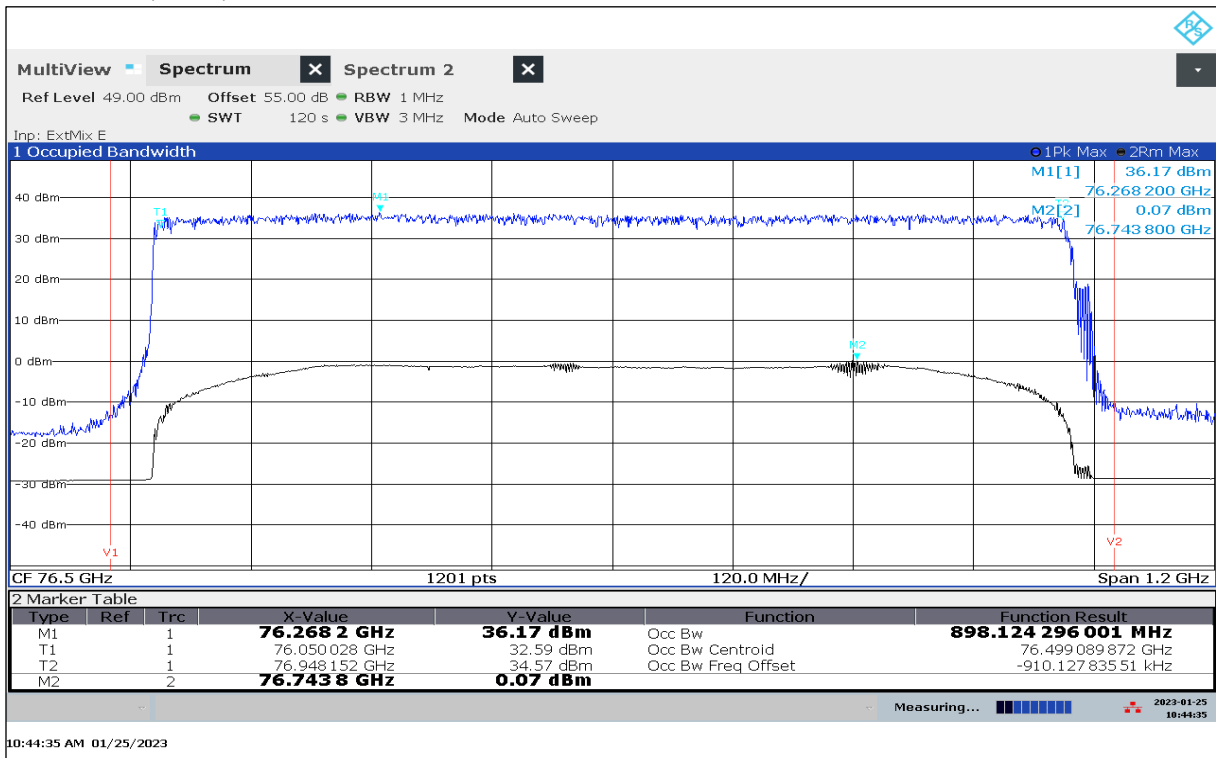

Plot 79: Mode 09, OBW, -10 °C / V_{min-max}

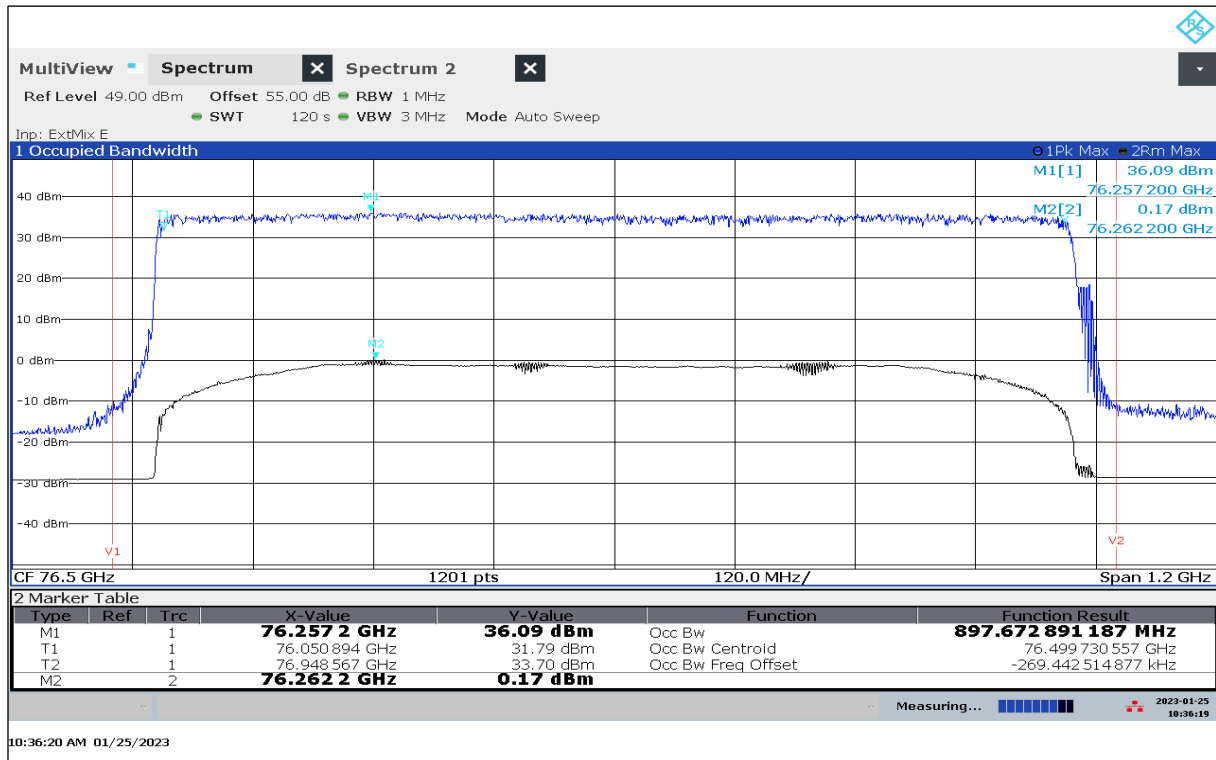

Plot 80: Mode 09, OBW, 0 °C / V_{min-max}

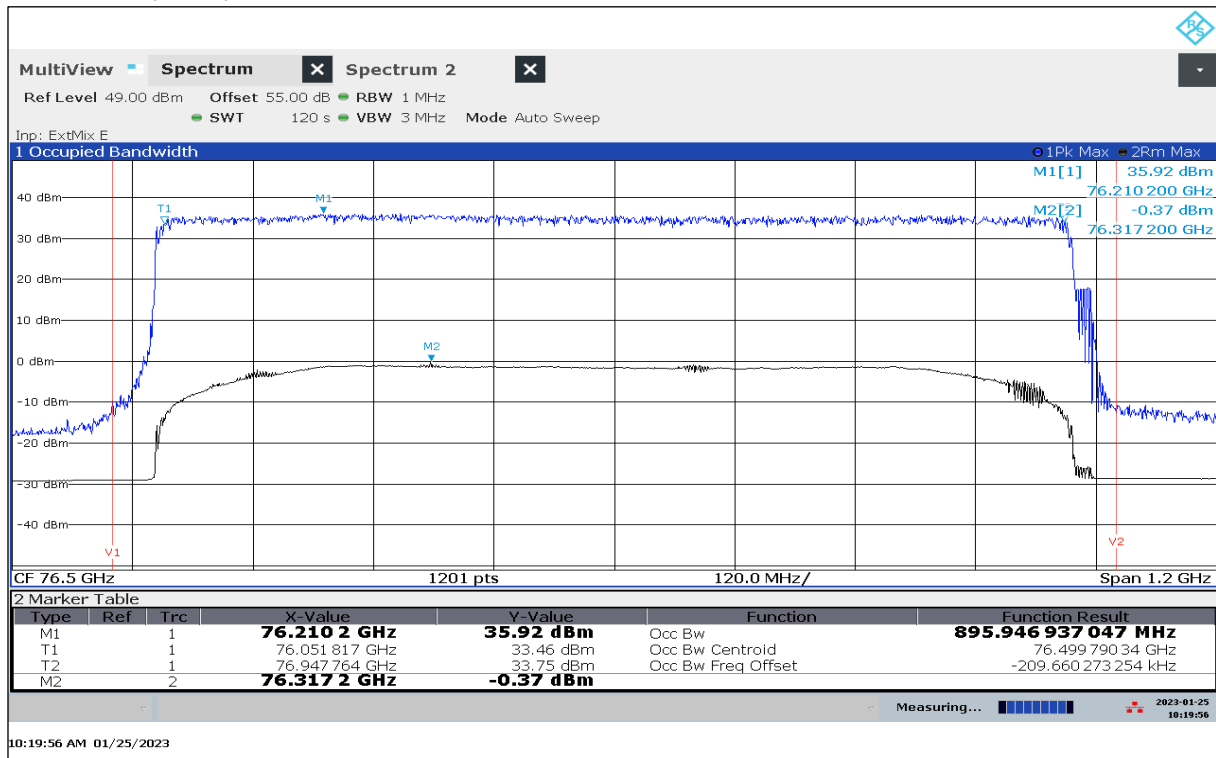

Plot 81: Mode 09, OBW, 10 °C / V_{min-max}

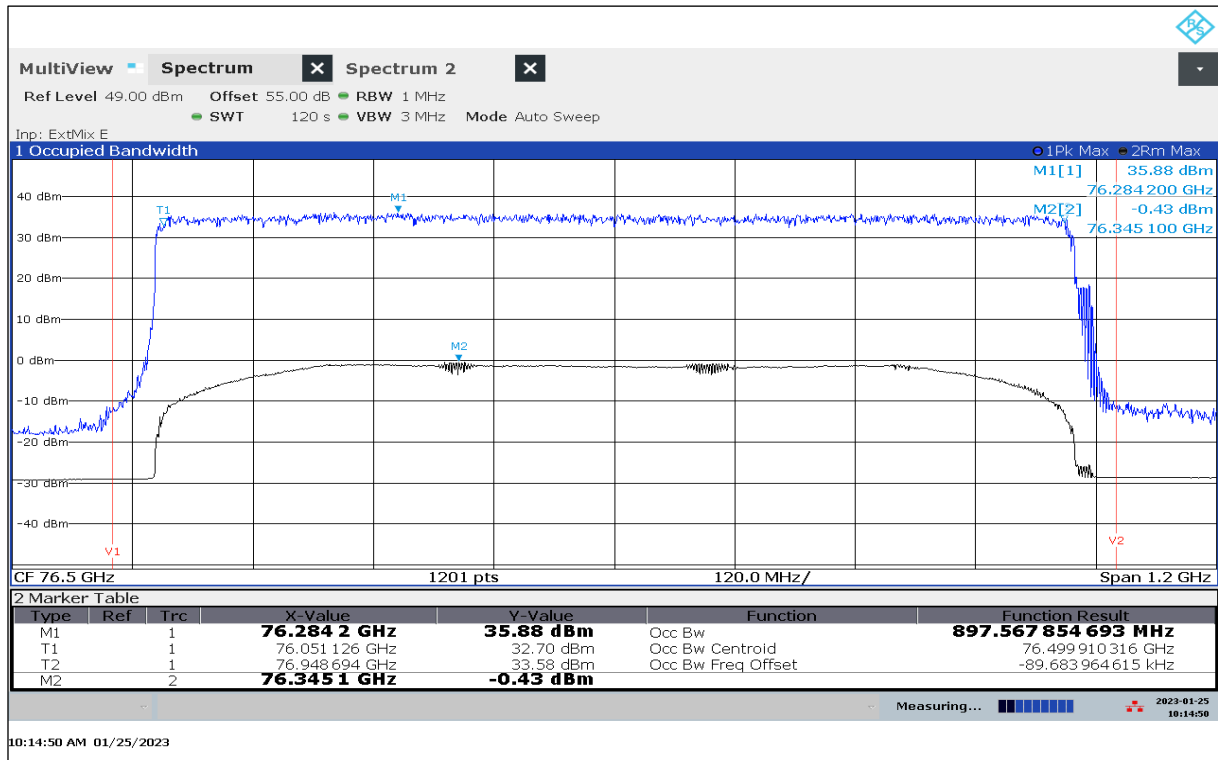

Plot 82: Mode 09, OBW, 20 °C / V_{min-max}

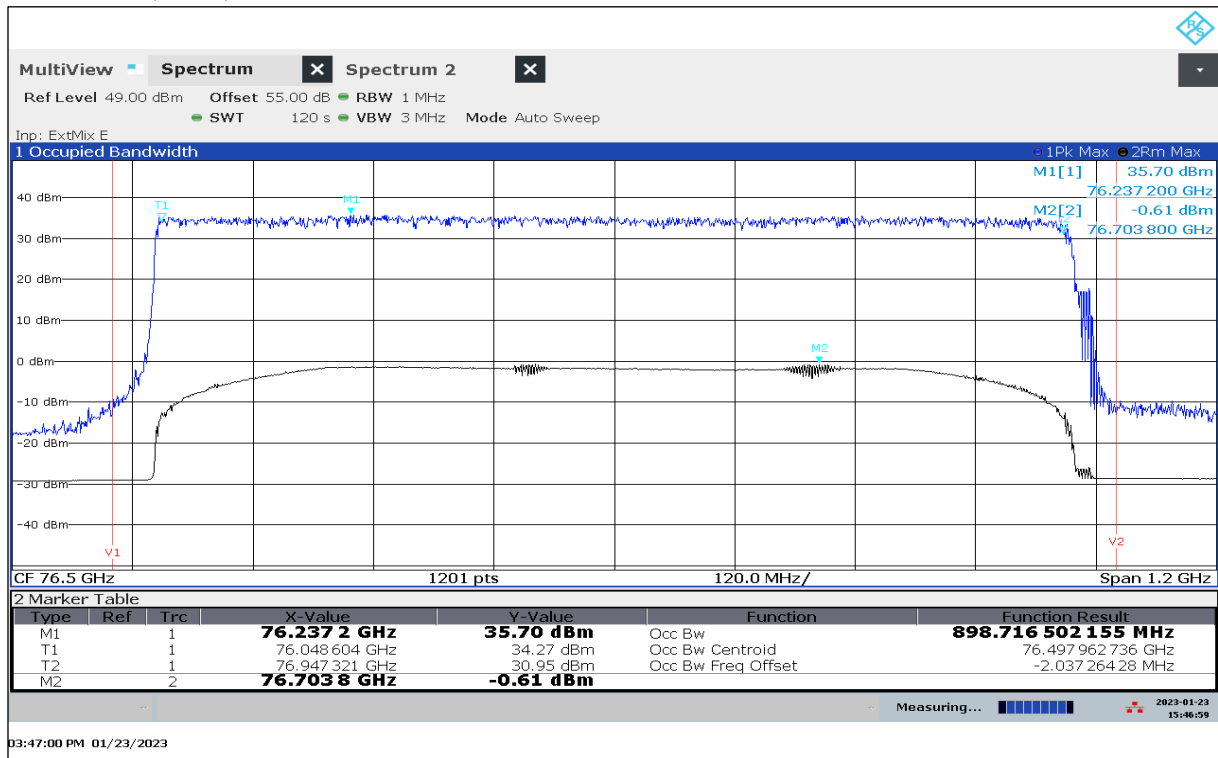

Plot 83: Mode 09, OBW, 30 °C / V_{min-max}

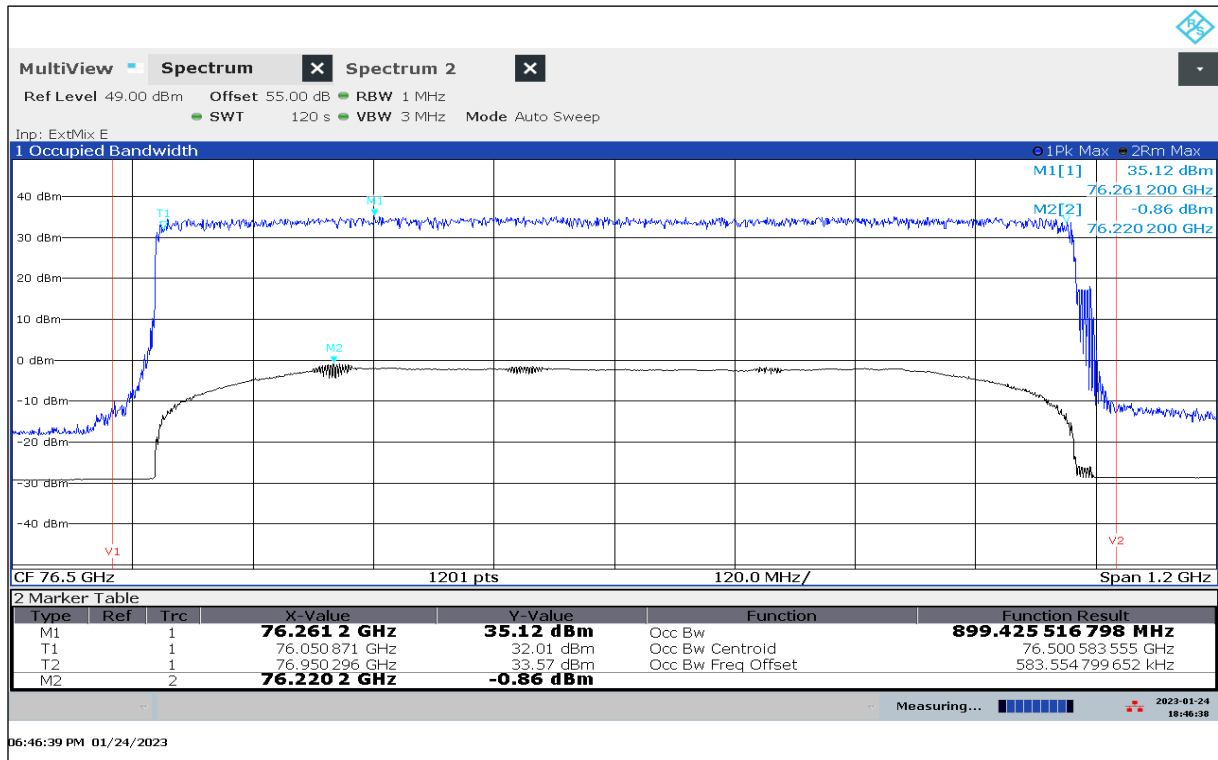

Plot 84: Mode 09, OBW, 40 °C / V_{min-max}

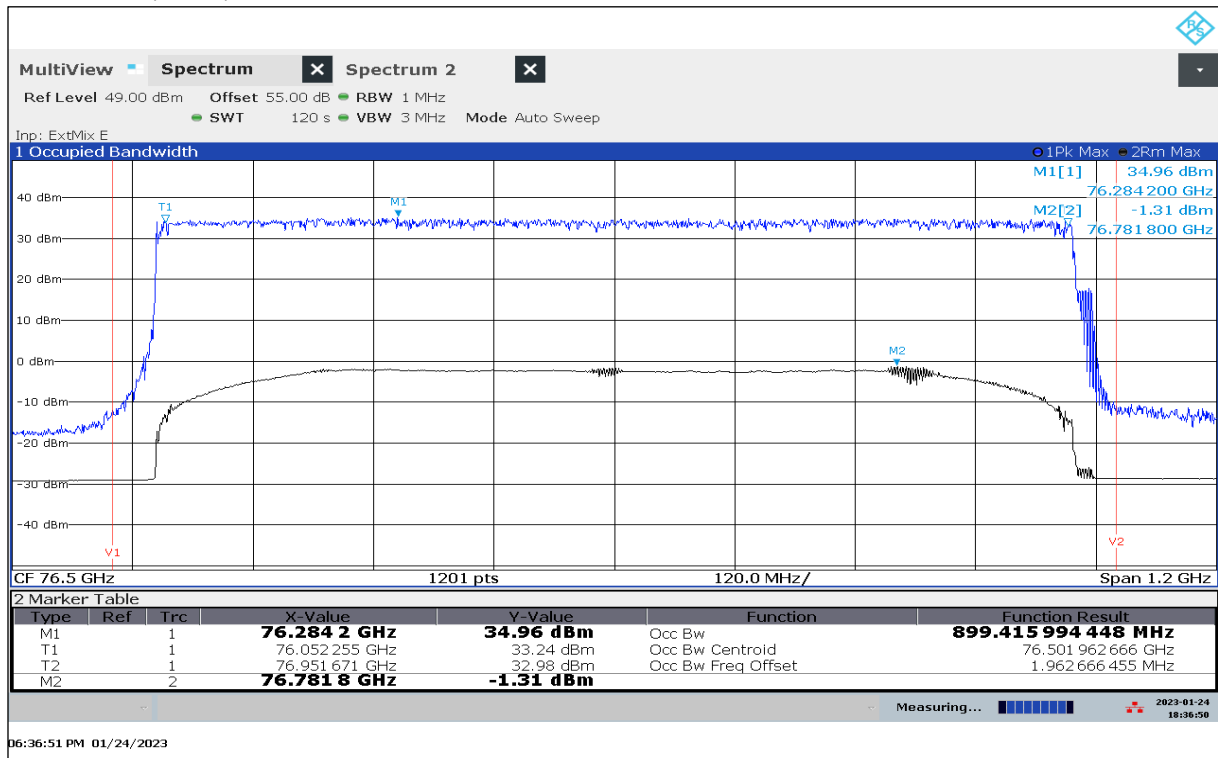

Plot 85: Mode 09, OBW, 50 °C / V_{min-max}

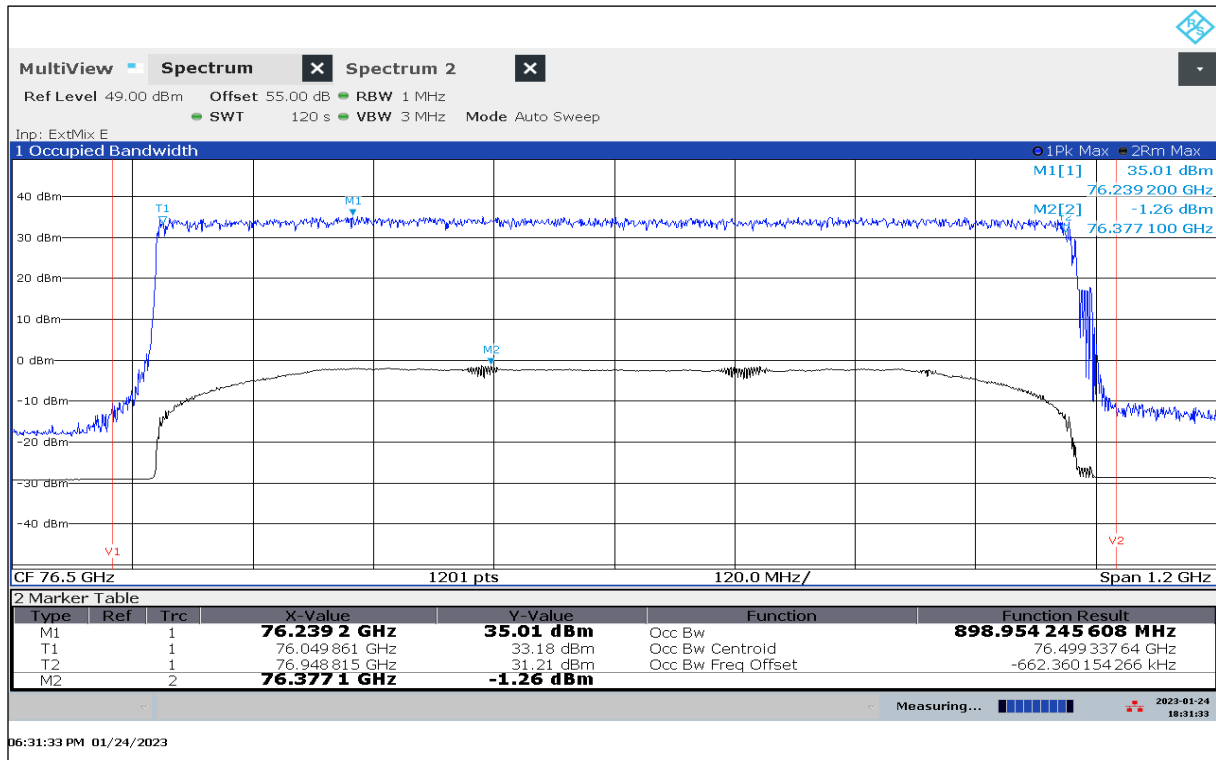

Plot 86: Mode 09, OBW, 85 °C / V_{min-max}

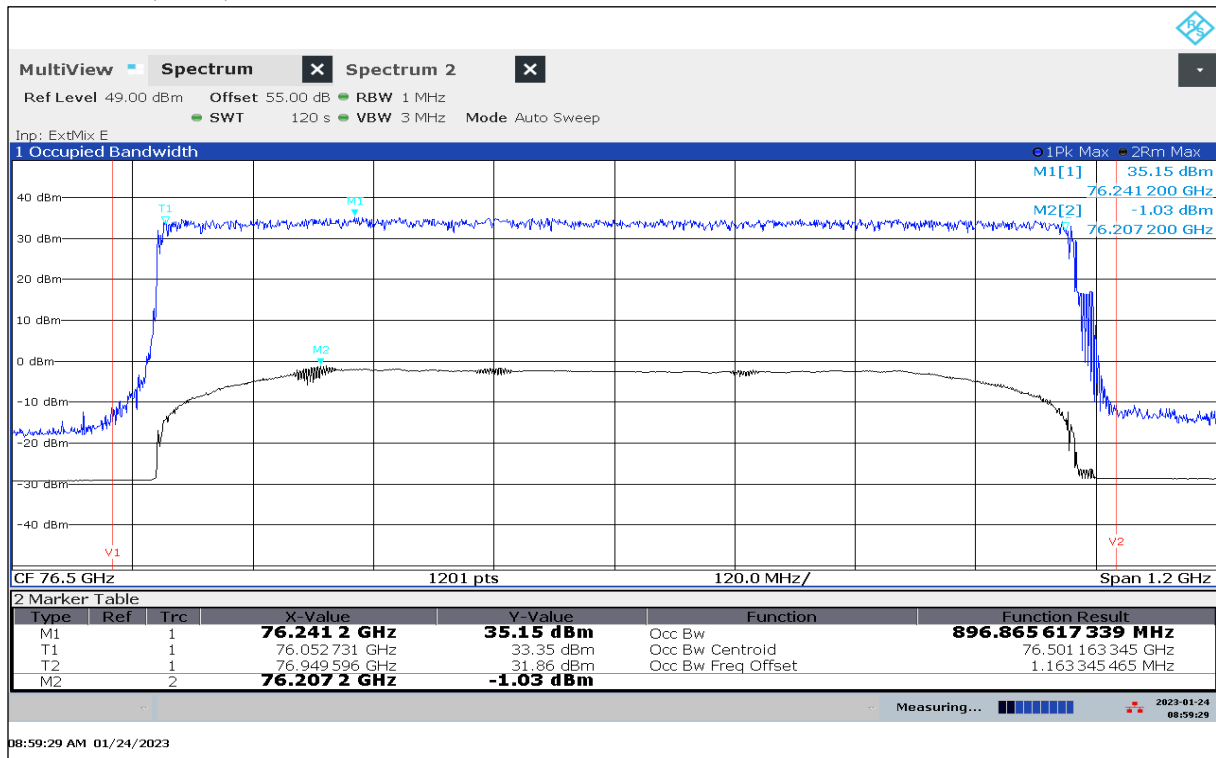

13 Glossary

EUT	Equipment under test
DUT	Device under test
UUT	Unit under test
GUE	GNSS User Equipment
ETSI	European Telecommunications Standards Institute
EN	European Standard
FCC	Federal Communications Commission
FCC ID	Company Identifier at FCC
IC	Industry Canada
PMN	Product marketing name
HMN	Host marketing name
HVIN	Hardware version identification number
FVIN	Firmware version identification number
EMC	Electromagnetic Compatibility
HW	Hardware
SW	Software
Inv. No.	Inventory number
S/N or SN	Serial number
C	Compliant
NC	Not compliant
NA	Not applicable
NP	Not performed
PP	Positive peak
QP	Quasi peak
AVG	Average
OC	Operating channel
OCW	Operating channel bandwidth
OBW	Occupied bandwidth
OOB	Out of band
DFS	Dynamic frequency selection
CAC	Channel availability check
OP	Occupancy period
NOP	Non occupancy period
DC	Duty cycle
PER	Packet error rate
CW	Clean wave
MC	Modulated carrier
WLAN	Wireless local area network
RLAN	Radio local area network
DSSS	Dynamic sequence spread spectrum
OFDM	Orthogonal frequency division multiplexing
FHSS	Frequency hopping spread spectrum
GNSS	Global Navigation Satellite System
C/N₀	Carrier to noise-density ratio, expressed in dB-Hz

14 Document history

Version	Applied changes	Date of release
-/-	Initial release - DRAFT	2023-02-12
-/-	Minor changes	2023-04-11

15 Accreditation Certificate – D-PL-12076-01-05

first page	last page
 <p>Deutsche Akkreditierungsstelle GmbH</p> <p>Entrusted according to Section 8 subsection 1 AkkStelleG in connection with Section 1 subsection 1 AkkStelleGBV Signatory to the Multilateral Agreements of EA, ILAC and IAF for Mutual Recognition</p> <p>Accreditation </p> <p>The Deutsche Akkreditierungsstelle GmbH attests that the testing laboratory CTC advanced GmbH Untertürkheimer Straße 6-10, 66117 Saarbrücken is competent under the terms of DIN EN ISO/IEC 17025:2018 to carry out tests in the following fields: Telecommunication (FCC Requirements)</p> <p>The accreditation certificate shall only apply in connection with the notice of accreditation of 09.05.2020 with the accreditation number D-PL-12076-01. It comprises the cover sheet, the reverse side of the cover sheet and the following annex with a total of 05 pages.</p> <p>Registration number of the certificate: D-PL-12076-01-05</p> <p>Frankfurt am Main, 09.06.2020  by order Dipl.-Ing. Frank Egnor Head of Division</p> <p><small>The certificate together with its annex reflects the status at the time of the date of issue. The current status of the scope of accreditation can be found in the database of accredited bodies of Deutsche Akkreditierungsstelle GmbH. https://www.dakks.de/en/content/accredited-bodies-dakks See notes annex 1.</small></p>	<p>Deutsche Akkreditierungsstelle GmbH</p> <p>Office Berlin Spittelmarkt 10 10117 Berlin</p> <p>Office Frankfurt am Main Europa-Allee 52 60327 Frankfurt am Main</p> <p>Office Braunschweig Bundesallee 100 38116 Braunschweig</p> <p>The publication of extracts of the accreditation certificate is subject to the prior written approval by Deutsche Akkreditierungsstelle GmbH (DAkKS). Exempted is the unchanged form of separate disseminations of the cover sheet by the conformity assessment body mentioned overleaf.</p> <p>No impression shall be made that the accreditation also extends to fields beyond the scope of accreditation attested by DAkKS.</p> <p>The accreditation was granted pursuant to the Act on the Accreditation Body (AkkStelleG) of 31 July 2009 (Federal Law Gazette I p. 2625) and the Regulation (EC) No 765/2008 of the European Parliament and of the Council of 9 July 2008 setting out the requirements for accreditation and market surveillance relating to the marketing of products (Official Journal of the European Union L 218 of 9 July 2008, p. 30). DAkKS is a signatory to the Multilateral Agreements for Mutual Recognition of the European co-operation for Accreditation (EA), International Accreditation Forum (IAF) and International Laboratory Accreditation Cooperation (ILAC). The signatories to these agreements recognise each other's accreditations.</p> <p>The up-to-date state of membership can be retrieved from the following websites: EA: www.european-accreditation.org ILAC: www.ilac.org IAF: www.iaf.nu</p>

Note: The current certificate annex is published on the websites (link see below).

<https://www.dakks.de/files/data/as/pdf/D-PL-12076-01-05e.pdf>

OR

https://cetecomadvanced.com/files/pdfs/d-pl-12076-01-05_tcb_usa.pdf

END OF TEST REPORT