

## RF TEST REPORT

<b>Applicant</b>	Spireon Inc
<b>FCC ID</b>	O9YKION
<b>Product</b>	GPS Tracker
<b>Brand</b>	Spireon
<b>Model</b>	ATS300
<b>Report No.</b>	R2303A0246-R1
<b>Issue Date</b>	April 23, 2023

TA Technology (Shanghai) Co., Ltd. tested the above equipment in accordance with the requirements in **FCC CFR47 Part 2 (2022)/ FCC CFR 47 Part 22H (2022)**. The test results show that the equipment tested is capable of demonstrating compliance with the requirements as documented in this report.

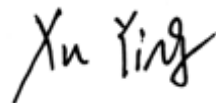

*Prepared by: Xu Ying*



*Approved by: Xu Kai*

---

**TA Technology (Shanghai) Co., Ltd.**

*Building 3, No.145, Jintang Rd, Pudong Shanghai, P.R.China*

*TEL: +86-021-50791141/2/3*

*FAX: +86-021-50791141/2/3-8000*

## TABLE OF CONTENT

1. Test Laboratory .....	4
1.1. Notes of the Test Report .....	4
1.2. Test Facility .....	4
1.3. Testing Location .....	4
2. General Description of Equipment Under Test .....	5
2.1. Applicant and Manufacturer Information .....	5
2.2. General Information .....	5
3. Applied Standards .....	6
4. Test Configuration .....	7
5. Test Case .....	8
5.1. RF Power Output and Effective Radiated Power .....	8
5.2. Radiated Spurious Emission .....	9
6. Test Result .....	12
6.1. RF Power Output and Effective Radiated Power .....	12
6.2. Radiated Spurious Emission .....	13
7. Main Test Instruments .....	15
ANNEX A: The EUT Appearance .....	16
ANNEX B: Test Setup Photos .....	17

## Summary of Measurement Results

No.	Test Case	Clause in FCC rules	Verdict
1	RF Power Output and Effective Radiated Power	2.1046 22.913(a)(5)	PASS
2	Radiated Spurious Emission	2.1053 / 22.917 (a)	PASS
Date of Testing: March 31, 2023 ~ April 10, 2023 Date of Sample Received: March 29, 2023			
Note: PASS: The EUT complies with the essential requirements in the standard. FAIL: The EUT does not comply with the essential requirements in the standard. All indications of Pass/Fail in this report are opinions expressed by TA Technology (Shanghai) Co., Ltd. based on interpretations and/or observations of test results. Measurement Uncertainties were not taken into account and are published for informational purposes only.			

**Only Radiated Spurious Emission is tested for ATS300 in this report, and because of the change of antenna gain, Effective Radiated Power also re evaluated.**  
**Other test items refer to the Module report (Report No.: R2006A0413-R1, FCC ID: XMR202007BG95M6).**

## 1. Test Laboratory

### 1.1. Notes of the Test Report

This report shall not be reproduced in full or partial, without the written approval of **TA Technology (Shanghai) Co., Ltd.** The results documented in this report apply only to the tested sample, under the conditions and modes of operation as described herein. Measurement Uncertainties were not taken into account and are published for informational purposes only. This report is written to support regulatory compliance of the applicable standards stated above.

### 1.2. Test Facility

#### **FCC (Designation number: CN1179, Test Firm Registration Number: 446626)**

TA Technology (Shanghai) Co., Ltd. has been listed on the US Federal Communications Commission list of test facilities recognized to perform measurements.

#### **A2LA (Certificate Number: 3857.01)**

TA Technology (Shanghai) Co., Ltd. has been listed by American Association for Laboratory Accreditation to perform measurement.

### 1.3. Testing Location

Company: TA Technology (Shanghai) Co., Ltd.  
Address: Building 3, No.145, Jintang Rd, Pudong Shanghai, P.R.China  
City: Shanghai  
Post code: 201201  
Country: P. R. China  
Contact: Xu Kai  
Telephone: +86-021-50791141/2/3  
Fax: +86-021-50791141/2/3-8000  
Website: <http://www.ta-shanghai.com>  
E-mail: [xukai@ta-shanghai.com](mailto:xukai@ta-shanghai.com)

## 2. General Description of Equipment Under Test

### 2.1. Applicant and Manufacturer Information

Applicant	Spireon Inc
Applicant address	18881 Von Karman Ave., Suite #1500, Irvine, CA 92612, United States
Manufacturer	Asiatelco Technologies Co.
Manufacturer address	No. 68 Huatuo Road, Building-8, Zhangjiang Hi-Tech Park, Pudong, Shanghai 201203, China

### 2.2. General Information

EUT Description			
Model	ATS300		
IMEI	862253061539575		
Hardware Version	2.0.0		
Software Version	3.8.15.13		
Power Supply	Battery		
Antenna Type	PIFA Antenna		
Antenna Gain	2 dBi		
Test Mode(s)	LTE-M Band 5;		
Test Modulation	QPSK, 16QAM;		
LTE Category	M1		
Maximum E.R.P.	LTE-M Band 5	23.83 dBm	
Rated Power Supply Voltage	12V		
Operating Voltage	Minimum: 8V    Maximum: 30V		
Operating Temperature	Lowest: -30°C    Highest: +70°C		
Operating Frequency Range(s)	Band	Tx (MHz)	Rx (MHz)
	LTE-M Band 5	824 ~ 849	869 ~ 894
EUT Accessory			
Battery	Manufacturer: RAMWAY Model: CR18505-4		
Note: 1. The EUT is sent from the applicant to TA and the information of the EUT is declared by the applicant.			

### 3. Applied Standards

According to the specifications of the manufacturer, it must comply with the requirements of the following standards:

**Test standards:**

**FCC CFR 47 Part 22H (2022)**

**FCC CFR47 Part 2 (2022)**

**Reference standard:**

**ANSI C63.26-2015**

**KDB 971168 D01 Power Meas License Digital Systems v03r01**

## 4. Test Configuration

Radiated measurements are performed by rotating the EUT in three different orthogonal test planes. EUT stand-up position (Z axis), lie-down position (X, Y axis). Receiver antenna polarization (horizontal and vertical), the worst emission was found in position (Z axis, horizontal polarization) and the worst case was recorded.

All mode and data rates and positions and RB size and modulations were investigated.

Subsequently, only the worst case emissions are reported.

The following testing in LTE-M is set based on the maximum RF Output Power.

Test modes are chosen as the worst case configuration below for LTE-M Band 5

Test items	Bandwidth (MHz)				Modulation		RB			Test Channel		
	1.4	3	5	10	QPSK	16QAM	1	50%	100%	L	M	H
RF power output and Effective Radiated power	O	O	O	O	O	O	O	O	O	O	O	O
Radiated Spurious Emission	O	-	O	O	O	-	O	-	-	-	O	-
Note	1. The mark "O" means that this configuration is chosen for testing. 2. The mark "-" means that this configuration is not testing.											

## 5. Test Case

### 5.1. RF Power Output and Effective Radiated Power

#### Ambient Condition

Temperature	Relative humidity	Pressure
23°C ~25°C	45%~50%	101.5kPa

#### Methods of Measurement

During the process of the testing, The EUT was connected to the Base Station Simulator with a known loss. The EUT is controlled by the Base Station Simulator test set to ensure max power transmission with proper modulation.

ERP can then be calculated as follows:

$EIRP \text{ (dBm)} = \text{Output Power (dBm)} + \text{Antenna Gain (dBi)}$

$EIRP \text{ (dBm)} = ERP \text{ (dBm)} + 2.15 \text{ (dB)}$ .

#### Test Setup

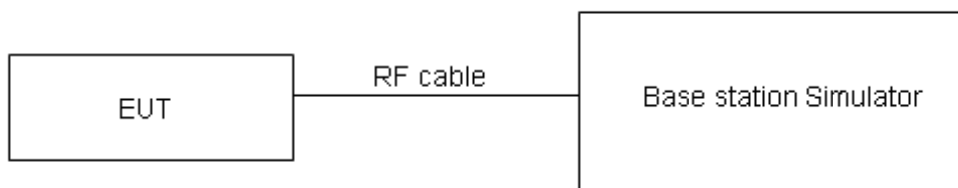

#### Limits

No specific RF power output requirements in part 2.1046.

Rule Part 22.913(a)(5) specifies that "Mobile/portable stations are limited to 7 watts ERP".

Limit	$\leq 7 \text{ W}$ (38.45 dBm)
-------	--------------------------------

#### Measurement Uncertainty

The assessed measurement uncertainty to ensure 95% confidence level for the normal distribution is with the coverage factor  $k = 2$ ,  $U = 0.4 \text{ dB}$  for RF power output,  $k = 2$ ,  $U = 1.19 \text{ dB}$  for ERP.

#### Test Results

Refer to the section 6.1 of this report for test data.



## 5.2. Radiated Spurious Emission

### Ambient Condition

Temperature	Relative humidity	Pressure
23°C ~25°C	45%~50%	101.5kPa

### Method of Measurement

- The testing follows FCC KDB 971168 v03r01 Section 5.8 and ANSI C63.26-2015.
- Below 1GHz: The EUT is placed on a turntable 0.8 meters above the ground in the chamber, 3 meter away from the antenna. The maximal emission value is acquired by adjusting the antenna height, polarisation and turntable azimuth. Normally, the height range of antenna is 1 m to 4 m, the azimuth range of turntable is 0° to 360°, and the receive antenna has two polarizations Vertical (V) and Horizontal (H). Above 1GHz: (Note: the FCC's permission to use 1.5m as an alternative per TCBC Conf call of Dec. 2, 2014.) The EUT is placed on a turntable 1.5 meters above the ground in the chamber, 3 meter away from the antenna. The maximal emission value is acquired by adjusting the antenna height, polarisation and turntable azimuth. Normally, the height range of antenna is 1 m to 4 m, the azimuth range of turntable is 0° to 360°, and the receive antenna has two polarizations Vertical (V) and Horizontal (H).
- A loop antenna, A log-periodic antenna or horn antenna shall be substituted in place of the EUT. The log-periodic antenna will be driven by a signal generator and the level will be adjusted till the same power value on the spectrum analyzer or receiver. The level of the spurious emissions can be calculated through the level of the signal generator, cable loss, the gain of the substitution antenna and the reading of the spectrum analyzer or receiver.
- The EUT is then put into continuously transmitting mode at its maximum power level during the test. Set Test Receiver or Spectrum RBW=100kHz, VBW=300kHz, and the maximum value of the receiver should be recorded as (Pr).
- The EUT shall be replaced by a substitution antenna. In the chamber, an substitution antenna for the frequency band of interest is placed at the reference point of the chamber. An RF Signal source for the frequency band of interest is connected to the substitution antenna with a cable that has been constructed to not interfere with the radiation pattern of the antenna. A power (PMea) is applied to the input of the substitution antenna, and adjust the level of the signal generator output until the value of the receiver reach the previously recorded (Pr). The power of signal source (PMea) is recorded. The test should be performed by rotating the test item and adjusting the receiving antenna polarization.
- A amplifier should be connected to the Signal Source output port. And the cable should be connect between the Amplifier and the Substitution Antenna. The cable loss (Pcl) ,the Substitution Antenna Gain (Ga) and the Amplifier Gain (PAg) should be recorded after test.
- The measurement results are obtained as described below:  
 Power (EIRP) = PMea - PAg - Pcl + Ga  
 The measurement results are amend as described below:  
 Power (EIRP) = PMea - Pcl + Ga
- This value is EIRP since the measurement is calibrated using an antenna of known gain (2.15 dB) and known input power. ERP can be calculated from EIRP by subtracting the gain of the dipole, ERP = EIRP-2.15dB.

The modulation mode and RB allocation refer to section 5.1, using the maximum output power configuration.

**Test Setup**

**9KHz~ 30MHz**

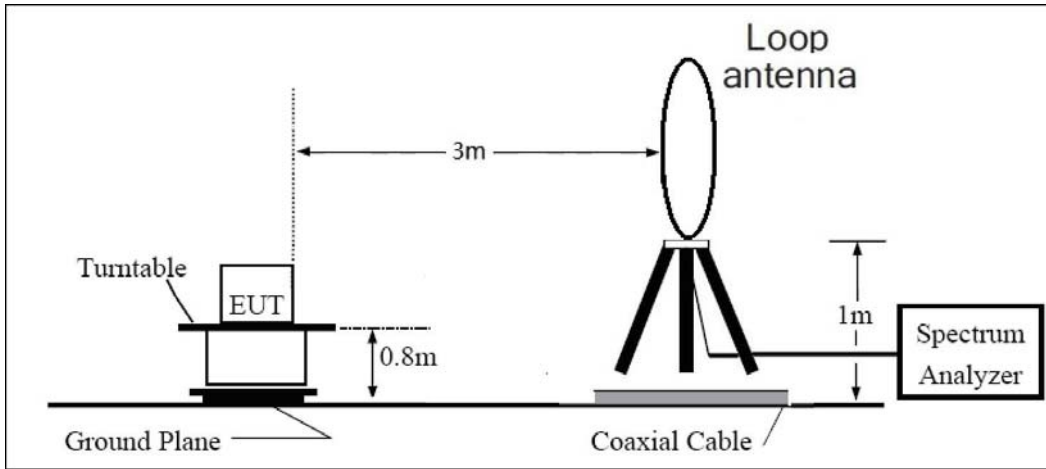

**30MHz~ 1GHz**

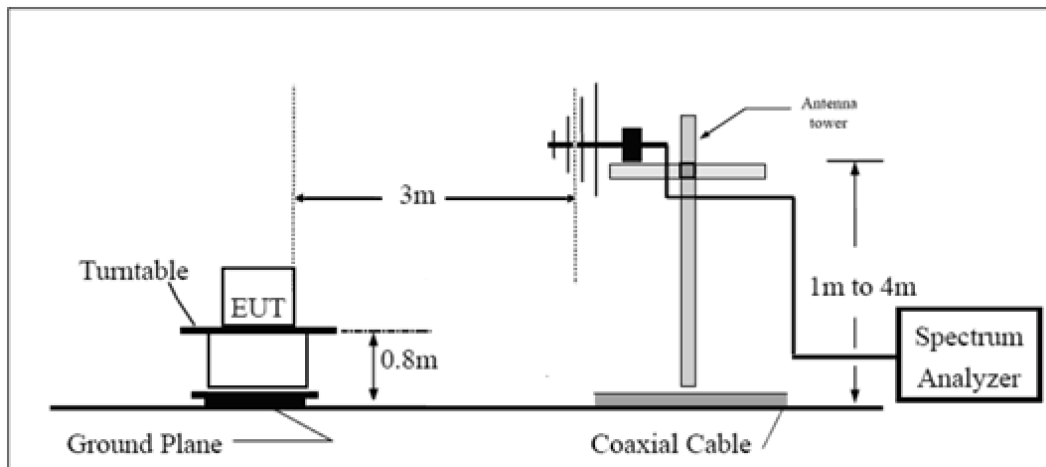

**Above 1GHz**

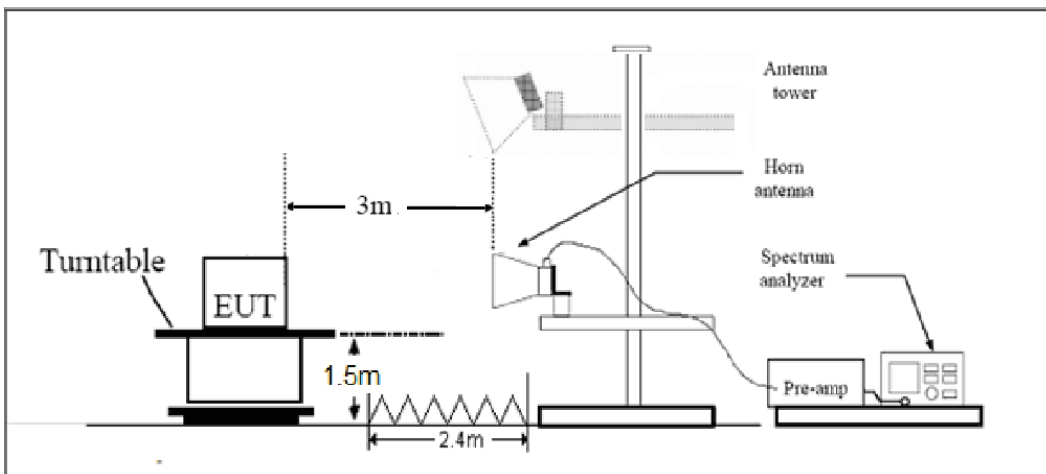

Note: Area side: 2.4mX3.6m

## Limits

Rule Part 22.917(a) specifies that “The power of any emission outside of the authorized operating frequency ranges must be attenuated below the transmitting power (P) by a factor of at least  $43 + 10 \log (P)$  Db.”

Limit	-13 dBm
-------	---------

## Measurement Uncertainty

The assessed measurement uncertainty to ensure 95% confidence level for the normal distribution is with the coverage factor  $k = 1.96$ ,  $U = 3.55$  Db.

## Test Results

Refer to the section 6.2 of this report for test data.

## 6. Test Result

### 6.1. RF Power Output and Effective Radiated Power

Band5	Channel/	Index	RB#	RB#	Conducted Power		ERP (dBm)	
			RBstart	RBstart	(dBm)		QPSK	16QAM
			QPSK	16QAM	QPSK	16QAM	QPSK	16QAM
1.4MHz	20407/824.7	0	1#0	1#0	23.22	23.04	23.07	22.89
		0	6#0	5#0	21.57	21.33	21.42	21.18
	20525/836.5	0	1#0	1#0	23.04	22.58	22.89	22.43
		0	6#0	5#0	21.27	21.13	21.12	20.98
	20643/848.3	0	1#5	1#5	23.64	23.13	23.49	22.98
		0	6#0	5#0	21.97	21.90	21.82	21.75
3MHz	20415/825.5	0	1#0	1#0	23.57	23.00	23.42	22.85
		0	6#0	5#0	21.46	21.58	21.31	21.43
	20525/836.5	0	1#0	1#0	23.65	22.32	23.50	22.17
		0	6#0	5#0	21.24	21.70	21.09	21.55
	20635/847.5	1	1#5	1#5	23.75	23.21	23.60	23.06
		1	6#0	5#0	22.01	22.02	21.86	21.87
5MHz	20425/826.5	3	1#0	1#0	23.42	23.65	23.27	23.50
		0	6#0	5#0	22.67	21.66	22.52	21.51
	20525/836.5	0	1#0	1#0	23.36	23.04	23.21	22.89
		0	6#0	5#0	22.41	21.73	22.26	21.58
	20625/846.5	0	1#5	1#5	23.98	23.55	23.83	23.40
		3	6#0	5#0	22.99	22.51	22.84	22.36
10MHz	20450/829	3	1#0	1#0	23.60	23.16	23.45	23.01
		0	4#0	4#0	23.65	23.03	23.50	22.88
	20525/836.5	0	1#0	1#0	23.51	23.10	23.36	22.95
		0	4#0	4#0	23.41	22.85	23.26	22.70
	20600/844	4	1#5	1#5	23.81	23.98	23.66	23.83
		7	4#2	4#2	23.95	23.24	23.80	23.09

## 6.2. Radiated Spurious Emission

Sweep the whole frequency band through the range from 9kHz to the 10th harmonic of the carrier, the emissions below the noise floor will not be recorded in the report.

LTE-M Band 5 1.4MHz CH-Middle

Harmonic	Frequency (MHz)	SG (dBm)	Cable Loss (dB)	Gain (dBi)	Antenna Polarization	ERP Level (dBm)	Limit (dBm)	Margin (dB)	Azimuth (deg)
2	1671.60	-40.84	1.70	8.70	Horizontal	-35.99	-13.00	22.99	90
3	2507.40	-53.39	2.30	12.00	Horizontal	-45.84	-13.00	32.84	235
4	3343.20	-61.29	2.70	12.70	Horizontal	-53.44	-13.00	40.44	279
5	4179.00	-65.07	3.00	12.50	Horizontal	-57.72	-13.00	44.72	140
6	5014.80	-61.57	3.40	12.50	Horizontal	-54.62	-13.00	41.62	202
7	5850.60	-61.51	3.40	12.80	Horizontal	-54.26	-13.00	41.26	306
8	6686.40	-60.34	4.10	11.50	Horizontal	-55.09	-13.00	42.09	0
9	7522.20	-56.61	4.20	12.20	Horizontal	-50.76	-13.00	37.76	176
10	8358.00	-57.62	4.30	12.50	Horizontal	-51.57	-13.00	38.57	90

Note: 1. The other Spurious RF Radiated emissions level is no more than noise floor.

2. The worst emission was found in the antenna is Horizontal position.

LTE-M Band 5 5MHz CH-Middle

Harmonic	Frequency (MHz)	SG (dBm)	Cable Loss (dB)	Gain (dBi)	Antenna Polarization	ERP Level (dBm)	Limit (dBm)	Margin (dB)	Azimuth (deg)
2	1668.60	-41.18	1.70	8.70	Horizontal	-36.33	-13.00	23.33	300
3	2503.30	-54.57	2.30	12.00	Horizontal	-47.02	-13.00	34.02	24
4	3336.00	-60.53	2.70	12.70	Horizontal	-52.68	-13.00	39.68	102
5	4170.00	-64.14	3.00	12.50	Horizontal	-56.79	-13.00	43.79	97
6	5004.00	-59.88	3.40	12.50	Horizontal	-52.93	-13.00	39.93	258
7	5838.00	-60.92	3.40	12.80	Horizontal	-53.67	-13.00	40.67	159
8	6672.00	-57.24	4.10	11.50	Horizontal	-51.99	-13.00	38.99	81
9	7506.00	-55.89	4.20	12.20	Horizontal	-50.04	-13.00	37.04	75
10	8340.00	-58.28	4.30	12.50	Horizontal	-52.23	-13.00	39.23	296

Note: 1. The other Spurious RF Radiated emissions level is no more than noise floor.

2. The worst emission was found in the antenna is Horizontal position.

## LTE-M Band 5 10MHz CH-Middle

Harmonic	Frequency (MHz)	SG (dBm)	Cable Loss (dB)	Gain (dBi)	Antenna Polarization	ERP Level (dBm)	Limit (dBm)	Margin (dB)	Azimuth (deg)
2	1663.00	-42.64	1.70	8.70	Horizontal	-37.79	-13.00	24.79	177
3	2494.50	-52.66	2.30	12.00	Horizontal	-45.11	-13.00	32.11	261
4	3326.00	-59.95	2.70	12.70	Horizontal	-52.10	-13.00	39.10	186
5	4157.50	-64.73	3.00	12.50	Horizontal	-57.38	-13.00	44.38	100
6	4989.00	-61.85	3.40	12.50	Horizontal	-54.90	-13.00	41.90	275
7	5820.50	-61.97	3.40	12.80	Horizontal	-54.72	-13.00	41.72	54
8	6652.00	-59.28	4.10	11.50	Horizontal	-54.03	-13.00	41.03	256
9	7483.50	-57.19	4.20	12.20	Horizontal	-51.34	-13.00	38.34	300
10	8315.00	-58.20	4.30	12.50	Horizontal	-52.15	-13.00	39.15	55

Note: 1. The other Spurious RF Radiated emissions level is no more than noise floor.

2. The worst emission was found in the antenna is Horizontal position.

## 7. Main Test Instruments

Name	Manufacturer	Type	Serial Number	Calibration Date	Expiration Date
Base Station Simulator	R&S	CMW500	113645	2022-05-14	2023-05-13
Signal Analyzer	R&S	FSV30	100815	2022-12-10	2023-12-09
Loop Antenna	SCHWARZBECK	FMZB1519	1519-047	2020-04-02	2024-04-01
TRILOG Broadband Antenna	Schwarzbeck	VULB 9163	391	2022-09-29	2025-09-28
Horn Antenna	Schwarzbeck	BBHA 9120D	1594	2020-12-17	2023-12-16
Software	R&S	EMC32	10.35.10	/	/

\*\*\*\*\*END OF REPORT \*\*\*\*\*

## ANNEX A: The EUT Appearance

The EUT Appearance is submitted separately.



## ANNEX B: Test Setup Photos

The Test Setup Photos is submitted separately.