

---

# User Manual

GPS tracker

**Wireless Communication Device**

May 07, 2020

The device comes pre-configured from the factory. It is ready to use. The Flex2-L appears to a user or a server application as an endpoint device. It can be queried, updated and configured either through a serial connection, an over the air IP connection, or through SMS messaging. The Flex2-L presents itself over these connections as an enhanced cellular modem with attached functional elements. These elements include:

- GPS location engine
- Accelerometer
- Input/outputs dedicated for ignition, relay, buzzer, and general purpose
- Serial UART port
- Timers
- Watchdog lockup protection
- Power management
- Event reporting
- Voltage monitoring

Access to these elements and general purpose interface is done through an extended AT command set. Configuration parameters are stored to flash memory and are automatically used on the next power up event. For more details, please reference the AT Command document.

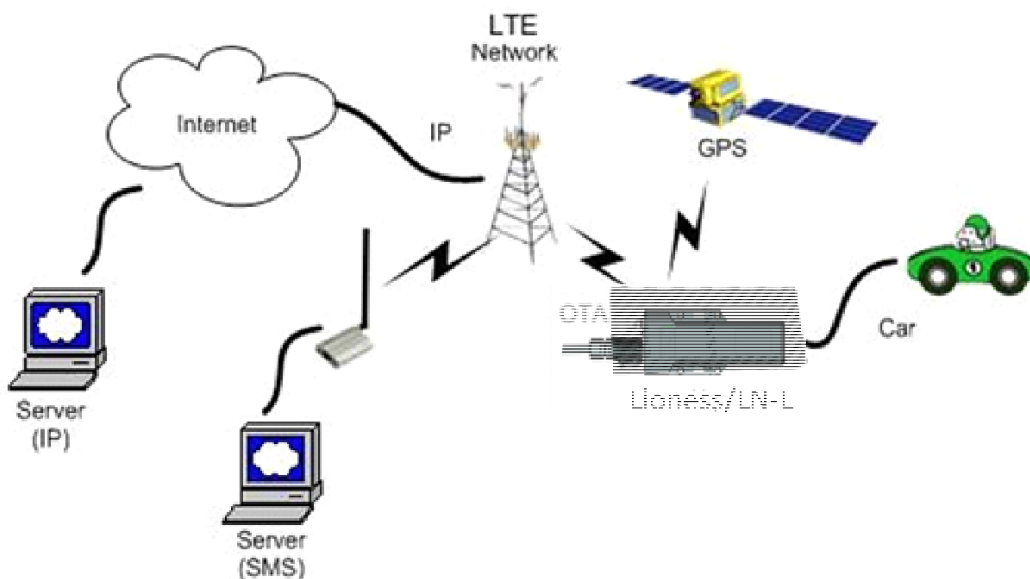

## 2 Hardware Design

### 2.1 Basic Hardware

Items	Requirement
Cellular Modem	Based on Quectel EC21-A Module
Cellular Network Interface	Support for LTE B2, B4, B12 WCDMA B2 B5

<b>Frequency</b>	B2:TX (1850--1910) MHZ RX (1930--1990) MHZ B4:TX (1710--1755) MHZ RX (2110--2155) MHZ B12:TX (699--716) MHZ RX (729--746) MHZ WCDMA B2:1900MHz WCDMA B5:850MHz
<b>Cellular Antenna</b>	Internal single antenna
<b>GPS Antenna</b>	Dedicate high performance ceramic antenna
<b>UIM requirement</b>	Support: 3FF SIM Interrupt Mode No Support: Hot Plug/Unplug
<b>Battery Monitor</b>	Internal analog input
<b>Build in battery manager</b>	Yes
<b>Interface</b>	Debug UART 12V DC Input (1A current) , Ground Relay Drive (Open Drain , 500mA current) Dedicated Output for buzzer control Ignition Input GPIO
<b>Dedicate Timers</b>	Yes
<b>Watchdog</b>	External HW via MCU
<b>Motion Detect</b>	Supported (GPS/G-Sensor)
<b>LED</b>	3 LED Supported 1- RED; 1- Green;1-Orange
<b>Battery</b>	built in battery (4400mAH Lion)
<b>Working Time</b>	6 months
<b>Power switch</b>	No
<b>Power Cable color</b>	4 or 6 colors
<b>Power Cable connector type</b>	12-pin connector+5pin
<b>Power Consumption</b>	< 5Watts

The Flex2-L provides support for specialized hardware features through extended AT commands. The features supported include the following:

### Accelerometer

The accelerometer can be used for motion detection and driver behavior monitoring.

### **3.2 Remote Update**

The Flex2-L supports OTA field upgrades of the resident application. An over the air FTP connection is made over an IP connection. A replacement file is then transferred from a server to the Flex2-L and that file replaces the previous application image.

### **3.3 Power Modes**

The Flex2-L device supports several power modes that are set by AT commands. In full power mode the GPS is active and the cellular subsystem will maintain a persistent cellular connection whenever service is available. IP connection is maintained according to the configuration of the device.

The device can be put in low power mode whenever it runs on a backup battery or if the external battery is low or if it is not moving. In low power mode the GPS is not running and the LED's are off. The device would return to full power whenever an event occurs that triggers a report. Those events include:

- Periodic report
- GPIO change
- IP change
- Battery threshold
- Heartbeat
- Watchdog
- Power-up
- Ignition
- Trip start and stop

Any hardware or software reset will return the device to full power mode.

---

## 4 Test Method

### 4.1 Hardware

Test Item	Description
Baseband Function Test	<ul style="list-style-type: none"><li>• Power Input Test</li><li>• Power Consumption and Current Test</li><li>• Heat Dissipation Test</li><li>• UART Stability Test</li><li>• GPIO Level Test</li><li>• LED Stability Test</li><li>• Drop Down Test</li><li>• ESD Test</li><li>• High/Low Temperature Test</li><li>• Humidity Test</li></ul>
RF Test	<ul style="list-style-type: none"><li>• RF Performance Test</li><li>• GPS Performance Test</li><li>• Antenna Performance Test</li></ul>

### 4.2 Software Test

#### Test Environment Construct

Message Test environment

1. USB dongle and PC as message server
2. Send message to Flex2-L

UDP Test environment

1. Connect dongle to PC and create dialup as ip server
2. Flex2-L create IP connection to server

UART Test environment

1. Connect Flex2-L to PC with com serial cable
2. Open Terminal tool and send at command
3. Response can be shown at terminal window

---

## Mechanical Structure (mm)

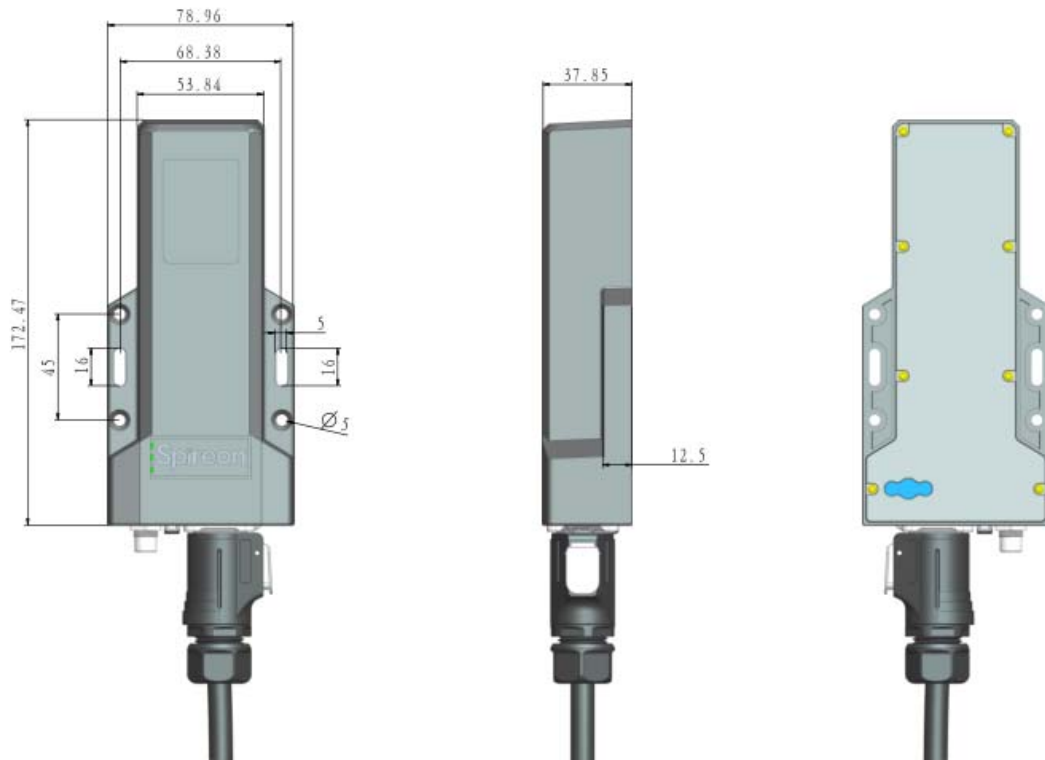

---

## FCC IC Statement

This device complies with part 15 of the FCC rules and RSS-247 of Industry Canada. Operation is subject to the following two conditions: (1) this device may not cause harmful interference, and (2) this device must accept any interference received, including interference that may cause undesired operation.

Le présent appareil est conforme aux CNR d'Industrie Canada applicables aux appareils radio exempts de licence. L'exploitation est autorisée aux deux conditions suivantes : (1) l'appareil ne doit pas produire de brouillage, et (2) l'utilisateur de l'appareil doit accepter tout brouillage radioélectrique subi, même si le brouillage est susceptible d'en compromettre le fonctionnement.

NOTE: The manufacturer is not responsible for any radio or TV interference caused by unauthorized modifications to this equipment. Such modifications could void the user's authority to operate the equipment.

This equipment has been tested and found to comply with the limits for a Class B digital device, pursuant to Part 15 of the FCC Rules. These limits are designed to provide reasonable protection against harmful interference in a residential installation. This equipment generates uses and can radiate radio frequency energy and, if not installed and used in accordance with the instructions, may cause harmful interference to radio communications. However, there is no guarantee that interference will not occur in a particular installation. If this equipment does cause harmful interference to radio or television reception, which can be determined by turning the equipment off and on, the user is encouraged to try to correct the interference by one or more of the following measures:

- Reorient or relocate the receiving antenna.
- Increase the separation between the equipment and receiver.
- Connect the equipment into an outlet on a circuit different from that to which the receiver is connected.
- Consult the dealer or an experienced radio/TV technician for help.

This equipment complies with FCC and IC radiation exposure limits set forth for an uncontrolled environment. This equipment should be installed and operated with minimum distance of 20 cm between the radiator and your body. This transmitter must not be co-located or operating in conjunction with any other antenna or transmitter.