



User Manual

905U- K Radio Telemetry Module

ELPRO Technologies Pty Ltd, 9/12 Billabong Street, Stafford Q 4053, Australia.

Tel: +61 7 33524533 Fax: +61 7 33524577 Email: sales@elpro.com.au

Web: www.elpro.com.au

Thank you for your selection of the 905U-K module for your telemetry needs. We trust it will give you many years of valuable service.

ATTENTION!

Incorrect termination of supply wires may cause internal damage and will void warranty.

To ensure your 905U-K enjoys a long life, **double check ALL your connections with the user's manual** before turning the power on.

CAUTION!

For continued against risk of fire, replace the module fuse F1 only with the same type and rating

This device should not be operated within 8 inches (20cm) of people in accordance with CFR 47 Section 1.1307

DO NOT:

- operate the transmitter when someone is within 20 cm of the antenna
- operate the transmitter unless all RF connectors are secure and any open connectors are properly terminated.
- operate the equipment near electrical blasting caps or in an explosive atmosphere

All equipment must be properly grounded for safe operations. All equipment should be serviced only by a qualified technician.

FCC Notice:***905U-K Wireless IO Module***

This user's manual is for the ELPRO 905U-K wireless module. This device complies with Part 15.247 of the FCC Rules.

Operation is subject to the following two conditions:

- 1) This device may not cause harmful interference and
- 2) This device must accept any interference received, including interference that may cause undesired operation.

This device must be operated as supplied by ELPRO Technologies. Any changes or modifications made to the device without the written consent of ELPRO Technologies may void the user's authority to operate the device.

This device MUST be installed by Professional Radio and Antenna personnel. Standard antenna cables, and antennas must be used, these are available from vendors specified by ELPRO Technologies. Please contact ELPRO Technologies for end user antenna and connector recommendations.

Safety Notice:

Exposure to RF energy is an important safety consideration. The FCC has adopted a safety standard for human exposure to radio frequency electromagnetic energy emitted by FCC regulated equipment as a result of its actions in Docket 93-62 and OET Bulletin 65 Edition 97-01.

Important Notice

ELPRO products are designed to be used in industrial environments, by experienced industrial engineering personnel with adequate knowledge of safety design considerations.

ELPRO radio products are used on unprotected license-free radio bands with radio noise and interference. The products are designed to operate in the presence of noise and interference, however in an extreme case, radio noise and interference could cause product operation delays or operation failure. Like all industrial electronic products, ELPRO products can fail in a variety of modes due to misuse, age, or malfunction. We recommend that users and designers design systems using design techniques intended to prevent personal injury or damage during product operation, and provide failure tolerant systems to prevent personal injury or damage in the event of product failure. Designers must warn users of the equipment or systems if adequate protection against failure has not been included in the system design. Designers must include this Important Notice in operating procedures and system manuals.

These products should not be used in non-industrial applications, or life-support systems, without consulting ELPRO Technologies first.

1. For 905U modules, a radio licence is not required in many countries, provided the module is installed using the antenna and equipment configuration complying with the country's regulations.. Check with your local distributor for further information on regulations.
2. For 905U modules, operation is authorised by the radio frequency regulatory authority in your country on a non-protection basis. Although all care is taken in the design of these units, there is no responsibility taken for sources of external interference. The 905U intelligent communications protocol aims to correct communication errors due to interference and to retransmit the required output conditions regularly. However some delay in the operation of outputs may occur during periods of interference. Systems should be designed to be tolerant of these delays.
3. To avoid the risk of electrocution, the antenna, antenna cable, serial cables and all terminals of the 905U/105S module should be electrically protected. To provide maximum surge and lightning protection, the module should be connected to a suitable earth and the antenna, antenna cable, serial cables and the module should be installed as recommended in the Installation Guide.
4. To avoid accidents during maintenance or adjustment of remotely controlled equipment, all equipment should be first disconnected from the 905U/105S module during these adjustments. Equipment should carry clear markings to indicate remote or automatic operation. E.g. "This equipment is remotely controlled and may start without warning. Isolate at the switchboard before attempting adjustments."
5. The 905U/105S module is not suitable for use in explosive environments without additional protection.

Limited Warranty, Disclaimer and Limitation of Remedies

ELPRO products are warranted to be free from manufacturing defects for a period of 2 years from the effective date of purchase. The effective date of purchase is decided solely by ELPRO Technologies.

This warranty does not extend to:

- failures caused by the operation of the equipment outside the particular product's specification, or
- use of the module not in accordance with this User Manual, or
- abuse, misuse, neglect or damage by external causes, or
- repairs, alterations, or modifications undertaken other than by an authorised Service Agent.

ELPRO's liability under this warranty is limited to the replacement or repair of the product. This warranty is in lieu of and exclusive of all other warranties. This warranty does not indemnify the purchaser of products for any consequential claim for damages or loss of operations or profits and ELPRO is not liable for any consequential damages or loss of operations or profits resulting from the use of these products. ELPRO is not liable for damages, losses, costs, injury or harm incurred as a consequence of any representations, warranties or conditions made by ELPRO or its representatives or by any other party, except as expressed solely in this document.

905U-K Radio Telemetry Module

USER MANUAL

LIMITED WARRANTY, DISCLAIMER AND LIMITATION OF REMEDIES	5
1 OVERVIEW	8
1.1 AVAILABLE MODELS	8
1.2 INPUT SIGNALS	8
1.3 POWER SUPPLY	9
1.4 RADIO TRANSMITTER	9
1.5 CONFIGURATION	9
2 OPERATION	10
2.1 NORMAL OPERATION	10
2.2 WHAT INFORMATION IS TRANSMITTED OVER THE RADIO?	10
2.3 HOW OFTEN IS THE INPUT INFORMATION SENT BY RADIO?	10
2.3.1 <i>Digital Inputs</i>	11
2.3.2 <i>Pulse Inputs</i>	11
2.3.3 <i>Analogue Inputs</i>	12
2.3.4 <i>Setpoint Status</i>	13
2.3.5 <i>Low Battery Voltage Alarm</i>	13
2.3.6 <i>Communications Failure</i>	14
2.4 HOW TO DESIGN A REMOTE MONITORING SYSTEM	14
2.4.1 <i>Achieving reliable radio transmission</i>	14
2.4.2 <i>How far will the radio transmit?</i>	15
2.5 CALCULATING POWER CONSUMPTION	15
3 HARDWARE INSTALLATION	18
3.1 HOW TO MOUNT THE 905U-K	19
3.2 ANTENNA INSTALLATION	19
3.3 CONNECTION PLUG	23
3.4 POWER SUPPLY INSTALLATION	24

3.4.1	<i>External Power</i>	24
3.5	INPUT SIGNAL CONNECTIONS	24
3.5.1	<i>Digital/Pulse Inputs</i>	24
3.5.2	<i>Shaft Encoder Connections</i>	26
3.5.3	<i>RS232 serial port</i>	26
4	CONFIGURATION -----	28
4.1	I/O MAPPING	29
4.2	UPDATE TRANSMISSION TIMES	29
4.3	DIGITAL INPUTS.....	30
4.4	ANALOGUE INPUT.....	30
4.5	ANALOG SETPOINTS	31
4.6	PULSE INPUTS.....	31
4.7	NUMBER OF TRANSMISSIONS	33
4.8	PROGRAMMING CONFIGURATIONS TO MODULES.....	33
4.9	LOADING CONFIGURATION FROM A MODULE	34
4.10	PRINT OPTIONS	34
5	TROUBLESHOOTING -----	35
6	SPECIFICATIONS -----	36

1 OVERVIEW

The 905U-K radio telemetry module is an economical solution for the remote monitoring of process signals. The 905U-K can connect to digital, pulse or analogue signals from process transducers, and transmit these signal values by radio.

Although the 905U-K is intended to be simple in its application, it also provides many sophisticated features. This manual should be read carefully to ensure that the modules are configured and installed to give reliable performance. The 905U-K uses the 905U module as a receiver, or repeater. If you have not used 905U modules before, please read the 905U User Manual prior to reading this manual.

The 905U-K module is a monitoring only unit - that is, it will **only accept input signals** and does not provide output signals. The 905U-K has an internal radio transmitter; it does not have a receiver to receive messages from another module.

The 905U-K transmits the value of an input signal whenever the signal changes, and also after a pre-configured time. Each transmission message includes error-checking to confirm the validity of the message. At each transmission, the 905U-K may be configured to repeat the transmission several times to ensure that the transmission is received correctly. This is important if the radio path is marginal (that is, the radio signal is not strong) or if there is a lot of radio traffic on the radio channel which may corrupt the 905U-K message. The 905U-K transmits the input message to a 905U module, which sets an output signal to be the same value as the 905U-K input, or the 905U passes the input message to another device (PC or PLC) via its serial port.

For more information on the 905U module, please refer to the 905U User Manual.

1.1 Available Models

The 905U-K has a heavy duty painted aluminium enclosure, weather-proof to NEMA 4. Signal and power connections to the unit are made via a weatherproof connector at the bottom of the module. Antenna connection is made using a SMA coaxial connector at the top of the module.

1.2 Input Signals

The 905U-K model provides two digital/pulse inputs and one analogue input for connecting to process transducers.

Digital Signals

Examples: motor fault, tank overflow, intruder alarm

Pulse signals - use the same input as the digital input

Examples: electricity metering, fluid flow, raingauge

Analogue continuously variable signals (0-20mA, 4-20mA, 0-10mA, 0 – 5V)

Examples: measured tank level, measured process temperature

Two *internal* signals may also be transmitted to outputs in the network:

- Setpoint Status (digital signal set or reset depending upon the value of the analogue signal compared to a high and a low setpoint value configured in the 905U-K)

- Battery Low Voltage (digital signal set when internal battery voltage is low).

1.3 Power Supply

The power consumption of the 905U-K is very small as it conserves power by reverting to “sleep” mode between transmissions.

The 905U-K can be powered from an external 12V DC supply, or a 5.4 – 30V battery supply. The battery supply can be an external battery pack. The 905U-K units provide an internal alarm on low battery voltage - this alarm may be transmitted by radio for warning purposes. The low battery alarm indicates that there is approximately 2% of battery capacity left.

1.4 Radio Transmitter

The 905U-K has an internal radio transmitter that operates on unlicensed spread spectrum radio channels in the 902 - 928MHz UHF band.

It is suitable for use in utility industries such as electricity, water and gas, as well as a cost effective solution for short range applications in factories and industrial plants.

The transmitter is preset in the factory to suit the unlicensed frequency requirements in each country. The maximum transmitter power is 1W. In countries where there are no unlicensed radio channels, a radio licence may be required each time the product is used. Please contact one of our worldwide distributors for further information.

To **extend radio range**, 905U modules can be used as repeaters. Up to five repeaters can be configured for each input-to-output link. The configuration is done at the 905U-K module where the input signal is - no additional configuration is required at the 905U modules. The transmitted radio message will include the address of repeater modules - modules with these addresses will re-transmit the messages.

1.5 Configuration

Each module must be configured before it can be used. Configuration is performed using a PC (or a laptop computer) connected to the module via the internal RS232 port on the 905U-K. 905U-K configuration software is required and is provided with each order.

Configuring a module requires the entering of “input mappings” and setting operating parameters for each input. An “input mapping” links an input signal to an output channel at a remote module (or a “destination address”). An input mapping is entered for each input signal (external and internal) which is used.

2 OPERATION

2.1 Normal Operation

Once configured using the 905U-K configuration software, the 905U-K module will normally be in “sleep” mode to conserve power. During sleep mode, the microprocessor controller powers down, and the analogue loop supply is turned off. The microprocessor will automatically “wake up” and revert to full operation if a digital/pulse input changes (*on to off*, or *off to on*), or every 0.5 seconds to check if a timed update transmission is due to be sent.

Normal operation of the 905U-K is indicated by a brief flicker of the OK LED light on the front panel approximately every 10 seconds.

2.2 What information is transmitted over the radio?

The 905U-K modules transmit the value of the input signal in a data frame. The data frame includes a system address, and the "address" of the transmitting (source) 905U-K module and the receiving (destination) 905U module, so that each transmitted message is acted on only by the correct receiving unit. The system address is a common address used by all modules in the same system. This allows multiple systems to operate within the same radio range without "cross-talk" between systems.

The user configures these addresses as part of the module configuration. Each transmitted message also includes error checking to ensure that no corruption of the data frame has occurred due to noise or interference. If repeater modules are being used, then the addresses of these intermediate modules are also included in the data frame.

The user can configure the 905U-K to transmit each message from one to five times to ensure that at least one of the messages is received correctly. Each repeat transmission will occur at random intervals between one and four seconds.

2.3 How often is the input information sent by radio?

- Change messages. The 905U-K transmits the value of an input signal whenever the signal changes.
- Update messages. The input value is also transmitted if the signal has not changed within a pre-configured update time (configurable 10 seconds to 5 days).
- Paralysis. When a 905U-K transmits a message for a particular input, the 905U-K will not transmit another message for this input within a configured time period. This time is called the paralysis time, and may be used to prevent a lot of messages being transmitted if an input changes frequently. The paralysis time may be set from zero to 127.5 seconds for each input. For example, assume the paralysis time on an input is 30 seconds. If the input changes, then the 905U-K will transmit a message, however it will not transmit another message for this input during the next 30 seconds, regardless of changes to the input signal. Note that paralysis time does not stop re-transmissions of each message - if the 905U-K is configured to transmit each message three times, then paralysis will not stop this.

Depending on the type of input signal (digital, pulse or analogue), the 905U-K must determine what type of signal change is required to send a transmission:

2.3.1 Digital Inputs

A digital input can be an external digital input or an internal status input (setpoint status or low battery alarm).

The 905U-K will transmit the value of the digital input whenever it changes from off to on or from on to off. A paralysis time may be configured to prevent another transmission within this time. The 905U-K will also transmit an update message if a message has not been transmitted for that input within an "update time".

There are two update times for each digital input - one for when the input is on, and one for when the input is off. Each update time may be configured between 10 seconds and 5 days. For example, a digital input may be configured to update every 1 day when the input is off, but update every 10 minutes when the input is on. If an update time of zero (or less than 10 seconds) is selected, then no update messages will be sent.

Overview:

- Input value transmitted on input change
- Update message if the input value has not been transmitted within the configured update time for that input (10 seconds - 5 days)
- Separate update times for on and off status for digital inputs
- After each transmission, further transmission for that input is disabled for the paralysis time (0 – 127.5 sec).

2.3.2 Pulse Inputs

Each pulse input is counted and the total count value is transmitted as a 16-bit value. A "sensitivity" value is configured for each pulse input (0 - 32 000). Whenever the pulse count has increased by this value since the last transmission, the 905U-K will transmit the new pulse count. In addition, an update transmission of the pulse count will be transmitted if the pulse count has not been transmitted for the update time. If an update time of zero is selected, then no update messages will be sent.

When the 905U receives the input count message, it will compare the input count to its own output count (the count of output pulses), and will then output pulses until the two counts are the same.

The maximum pulse input is 1000Hz (3 msec minimum on-time and off-time). There is no minimum pulse rate. For pulse rates higher than 1Hz, the power consumption will increase slightly. For pulse rates higher than 10 Hz, the "Fast Pulsed Inputs" option should be selected. This increases power consumption of the module further.

If the pulse input message is sent to a host device, it is important to note that the count value transmitted is an absolute value. The only time that it resets is when the 16-bit accumulator "rolls over" (exceeds 65 535).

Overview:

- Pulse inputs are counted.
- Pulse count is transmitted when the count has increased by the sensitivity amount since the last transmission.

- Update message if the input value has not been transmitted within the update time (10 seconds - 5 days).
- After each transmission, another transmission for that input is disabled for the paralysis time (0 – 127.5 sec).

For the 905U-K-2, the two pulse inputs may be configured to control one count value, for use with quadrature and incremental shaft encoders. A shaft encoder is a transducer that measures level or displacement, and has two pulse signals to indicate change of level and direction of change.

Both pulse inputs are read at the same time.

If using an incremental encoder, the count is the value of Pulse Input 1. This pulse input value should be used to send the true pulse count from a incremental encoder.

If using a quadrature encoder, the count is the value of Pulse Input 2. This pulse input value should be used to send the true pulse count from a quadrature encoder.

2.3.3 Analogue Inputs

The analogue input uses a “sample time” and “warm-up time” configured by the user. The sample time (1 minute to 20 days) “wakes” the 905U-K from sleep mode and turns on the analogue loop supply. The “warm-up time” (0.5 – 127.5 seconds) allows the transducer to reach rated accuracy before the 905U-K makes a measurement of the analogue signal.

For example, if the sample time is 30 minutes and the warm-up time is 10 seconds, then every 30 minutes, the 905U-K will turn on its analogue loop supply and after a further 10 seconds, take a measurement of the analogue signal. After the measurement is taken, the 905U-K reverts to sleep mode. If the sample time is set to zero, then the analogue loop supply will be on continuously and measurement will be taken based on the warm-up time. If the warm-up time is 1 second, then a measurement is taken every 1 second.

The same process occurs if an externally powered analogue signal is connected.

The measurements have a resolution of 12 bit, and an overall accuracy of better than 0.1%.

When the 905U-K takes a measurement, it will transmit the analogue value if the value has changed by more than the pre-configured sensitivity since the last transmission. The sensitivity can be configured from 0.25% to 100% (0.05mA to 20mA) with a default value of 3% (0.6mA). If the change in the signal since the last transmitted value is less than the sensitivity, then the 905U-K will not transmit the analogue value.

In addition, an update transmission of the analogue value will be transmitted if the analogue value has not been transmitted for the update time (10 seconds - 5 days). If an update time of zero is selected, then no update messages will be sent.

If the update time expires since the last transmission, then the last measured value will be transmitted - that is, a new measurement will not be taken. Normally the update time will be much longer than the sample time. If the update time is less than the sample time, then update messages may transmit the same value as the previous transmission, as a new measurement has not yet been taken.

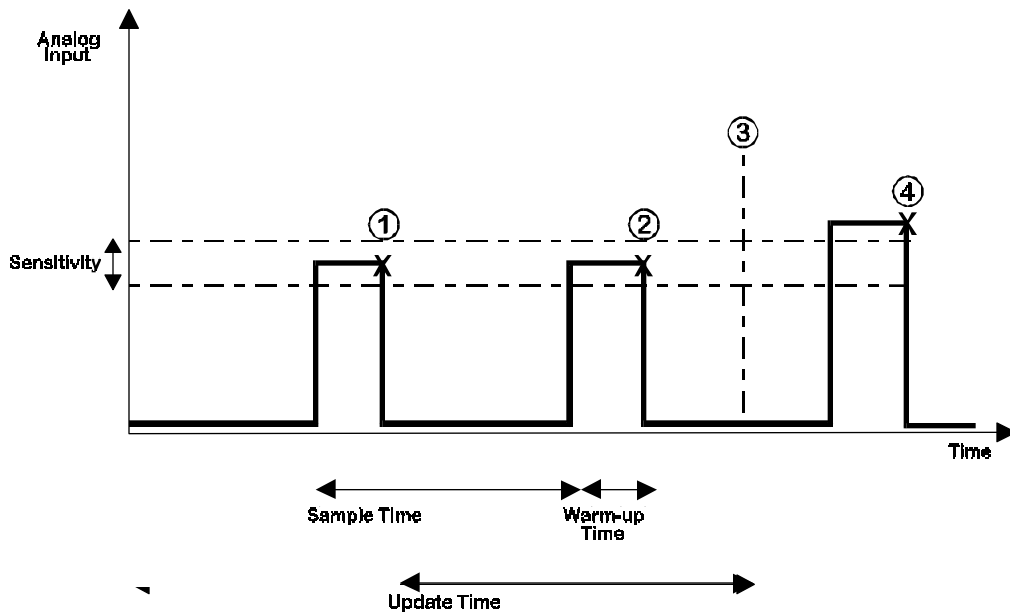

- ① Measurement taken and input value transmitted.
- ② Measurement taken - as input value has not changed by more than sensitivity, no transmission.
- ③ Update time reached, last measured value is transmitted.
- ④ Measurement taken - as input value has changed by more than the sensitivity, the input value is transmitted.

Overview:

- Measurements of the analogue signal are determined by the sample time and warm-up time
- Analogue value is transmitted if the measured value has increased by the configured sensitivity amount since the last transmission
- Analogue value is transmitted if the input value has not been transmitted within the update time (10 seconds - 5 days)

2.3.4 Setpoint Status

The setpoint status is an internal status value, calculated by comparing the analogue input to two configurable setpoint values. The setpoint status turns ON when the analogue input moves below the low setpoint value, and turns OFF when it moves above the high setpoint value. The high setpoint percentage must always be greater than, or equal to, the low set point.

The internal setpoint status will be determined every time an analogue measurement is taken.

The setpoint status is treated as a digital signal and its value is transmitted according to the rules for a digital input.

2.3.5 Low Battery Voltage Alarm

The Low Battery Voltage Alarm is a configurable set point determined by the type of battery used to power the 905U-K. If the voltage of battery supply falls below the set point voltage, the internal battery voltage alarm will turn on.

The Low Battery Voltage Alarm is treated as a digital signal and its value is transmitted according to the rules for a digital input.

If the battery is not replaced at the point of Low Voltage Alarm, at a point of 95% of the set point value, the unit will be permanently put into 'sleep' mode to prevent damage from over discharge to lead acid batteries.

2.3.6 Communications Failure

The 905U-K cannot provide an indication that its transmitted messages have not been received successfully.

This indication is however available at the **receiving 905U** by using the 905U Output Reset on Comms Fail function. To use this function, map an input that is not being used on the 905U-K to a spare output on the 905U. The unused input can be an internal input such as the Low Battery status or Setpoint status, or even the analogue input as this can also be mapped to a digital output. Configure the 905U-K so that the digital output at the 905U is normally on - you can configure an input to output mapping to be inverted or direct.

If you configure a reset time to the 905U output, then this output will turn off if it has not received an update message from the 905U-K within that time. The 905U output is effectively a "Communications OK" output - on when communications are OK, and off during communications failure. Note that the maximum output reset time at the 905U is 32 minutes, so the update time for the 905U-K input must be less than this. It is generally a good idea to set the update time to less than half of the reset time. Then, the 905U must fail to receive two consecutive update messages - it is possible to miss one update message because of random noise, but two consecutive failures means that there is a system failure. For example, if you wish to have a failure alarm within 10 minutes of a system failure, set the output reset time at the 905U to 10 minutes and the update time at the 905U-K to 4.5 minutes.

2.4 How to Design a Remote Monitoring System

2.4.1 Achieving reliable radio transmission

A system can theoretically have an unlimited number of 905U-K modules, but in practice, the number is limited by the amount of radio traffic on one frequency in the system. When a radio channel becomes unreliable because of radio traffic, then a second radio channel must be used to increase the size of the system. This limit is not a function of the number of modules, but the number of radio messages.

A system comprises 905U-K and 905U modules - each can transmit input signals. The 905U can "hear" other radio messages, and will hold off transmitting a message until the radio channel is clear. The 905U-K module cannot, and there is a possibility that an individual transmission will clash with another transmission, and both transmissions will be corrupted. This possibility increases as the density of transmissions increases. Configuring the re-transmit feature (transmission of each message several times) will increase the chance of each message being received successfully, but will increase the overall density of radio traffic.

For large systems, a compromise is required between the number of re-transmissions, and the update times for each input. High priority inputs should have shorter update times than lower priority inputs.

The peak transmission density should be calculated for large systems. These values are calculated by determining the number of transmissions from inputs changing value and the number of update transmissions per hour.

The probability of success for an individual message depends on the transmission density and the number of re-transmissions for each message. This is shown in the following graph:

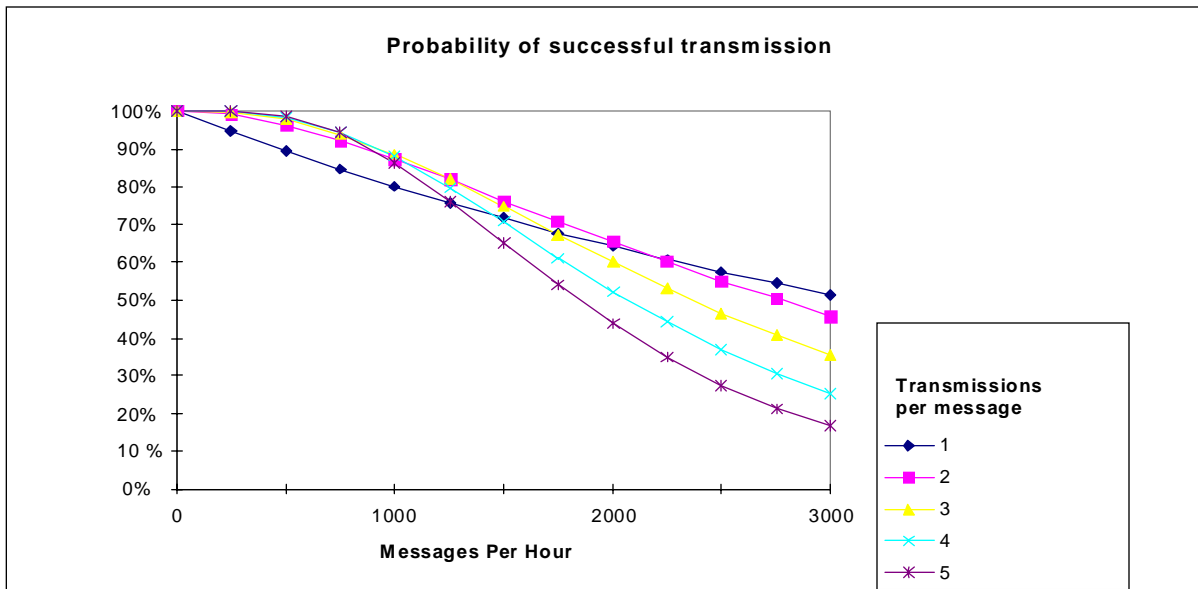

This assumes that the radio path is reliable and that there is no other radio users on this radio channel. If intermediate repeaters are used, then each repeated message should be counted as another message.

We suggest that you use two transmissions per message - with a higher number for a small number of high priority inputs.

In addition to the above comments, you need to consider the affect of re-transmissions on other messages being transmitted from the same 905U-K module. Once a 905U-K starts transmitting a message, all transmissions for this message must be complete before another transmission can start. The time between retransmissions of the same message is a random time between 0.5 and 4 seconds. For example, if a module is configured to transmit each message 5 times, then each message will take up to 16 seconds. Another message cannot be transmitted until the previous message has finished. In the above example, the maximum number of messages which can be transmitted reliably is approx 4 per minute. If more messages are required, then a lower number of re-transmissions should be selected.

2.4.2 How far will the radio transmit?

The 905U-K will operate reliably over large distances. The distance that may be reliably achieved will vary with each application and is dependent on the following factors:

- Type and location of antennas (the higher an antenna is, the further it will transmit)
- Amount of radio interference from other transmitters or radio “noise”
- Obstructions such as buildings, hills or trees in the radio path
- Maximum radio transmitter power allowed in the country

The transmitter power level of each 905U-K is set in the factory to the maximum power allowed in the country of sale. The maximum output power of the 905U-K is 1 Watt,

2.5 Calculating Power Consumption

The following information may be used for calculating power consumption.

mA

Quiescent		0.10
Each radio transmission	1.0 W Radio	350
Analogue input measurement (per measurement)	Externally powered transducer	10
	Loop Powered Transducer - 12 mA average	22
	Loop Powered Transducer - 20 mA average	30
Pulsed Input	0 - 10 Hz (Slow Pulsed Inputs)	0.0025 x f
	10 - 1000 Hz (Fast Pulsed Inputs)	0.2

w-time = warm up time in seconds f = pulse frequency in Hz

The overall power requirements may be calculated by using the above figures.

$$\begin{aligned}
 \text{Total power per day} &= \text{Quiescent} \\
 &+ \quad \text{Pulse input (if used)} \\
 &+ \quad \text{Analogue input per measurement} \times \text{number of measurements per day} \\
 &+ \quad \text{Radio transmission} \times \text{number of radio transmissions per day}
 \end{aligned}$$

There is no additional power required for digital inputs.

Where an external battery supply is used, these figures can be used to determine the expected battery life.

Example:-

An application has one digital input, one pulse input and one analogue input. It is powered by internal battery supply and the analogue input uses the 905U-K loop supply. Each radio message is configured to transmit two times.

The total power consumed = power for transmissions + power for analogue loop supply + pulse input + quiescent

Power for radio transmissions:-

The configuration parameters, and estimated activity data, for each input are:

Digital input Update time, off state 1 day
 Update time, on state 15 minutes
 Input is expected to be on twice per year for 4 hours

$$\begin{aligned}
 \text{No. of change messages per year} &= 2 \text{ (twice per year)} * 2 \text{ (on to off and off to on)} \\
 &= 4
 \end{aligned}$$

$$\text{No. of off update messages per year} = 364 \text{ (approximately)}$$

$$\begin{aligned}
 \text{No. of on update messages per year} &= 2 \text{ (twice per year)} * 16 \text{ (4 hours @ 15 min update)} \\
 &= 32
 \end{aligned}$$

$$\text{Total messages for digital input} = 4 + 364 + 32 = 400$$

Pulse input Update time 1 day Sensitivity 50

Average pulse rate is 1 pulse per hour, with peak rate of 20 per hour, for 10 hours, three times per year.

$$\text{No. of change messages (normal rate)} = 0 \text{ (time for 50 pulses is more than the update time)}$$

$$\text{No. of change messages (peak rate)} = 3 \text{ (three per year)} * 200 \text{ (20 per hr for 10 hrs)} / 50$$

$$\begin{aligned}
 &= 12 \\
 \text{No. of update messages per year} &= 363 \text{ (approx)} \\
 \text{Total messages for pulse input} &= 12 + 363 = 375 \\
 \text{Analogue input} \quad \text{Sample time 1 hour} & \qquad \qquad \qquad \text{Warm-up time 5 secs} \\
 \qquad \qquad \qquad \text{Sensitivity 3\%} & \qquad \qquad \qquad \text{Update time 1 day} \\
 \qquad \qquad \qquad \text{Average changes of >3\% is twice per day} & \\
 \text{No. of change messages per year} &= 2 \text{ (twice per day)} * 365 \\
 &= 730 \\
 \text{No. of update messages per year} &= 0 \text{ (always be a change message each 1 day)} \\
 \text{Total messages for analogue input} &= 730 \\
 \text{Total input messages per year} &= 400 + 375 + 730 = 1505 \\
 \text{Power consumed in transmissions} &= 350 * 1505 * 2 \text{ (2 per message)} \\
 &= 1,053,500 \text{ } \mu\text{A-hour per year}
 \end{aligned}$$

Power for analogue loop supply (assume average loop current is 12mA)

$$\begin{aligned}
 \text{No. of analogue measurements per year} &= 365 \text{ days} * 24 \text{ hours} * 1 \text{ (sample time)} \\
 &= 8,760 \\
 \text{Power for analogue loop supply} &= 17 \text{ (from above table)} * 5 \text{ (warm-up time)} * 8,760 \\
 &= 744\,600 \text{ } \mu\text{A-hour per year}
 \end{aligned}$$

Power for pulse input

$$\begin{aligned}
 \text{Average pulse rate is 1 pulse per hour (0.0003Hz), so power required} &= 60 * 0.0003 \text{ per day} \\
 &= 7 \text{ } \mu\text{A-hour per year}
 \end{aligned}$$

Quiescent power

$$\begin{aligned}
 \text{Power for quiescent current} &= 3600 \text{ per day} * 365 \\
 &= 1\,314\,000 \text{ } \mu\text{A-hour per year}
 \end{aligned}$$

$$\begin{aligned}
 \text{Total power consumption per year} &= 1\,053\,500 + 744\,600 + 7 + 1\,314\,000 \\
 &= 3,112,107 \text{ } \mu\text{A-hour}
 \end{aligned}$$

3 HARDWARE INSTALLATION

WARNING! All connections to the 905U-K must be SELV only. 110/220/240V mains power must NOT be connected to any input terminal of the 905U-K module!

The 905U-K module is housed in a weatherproof enclosure with external power and input signals connected via a weatherproof connector at the bottom of the module.

Wires of up to 0.75 sqmm may be connected by soldering to the female connector supplied with the unit. The antenna/coaxial cable connector is a SMA at the top of the module. Care should be taken to ensure that this connection remains weatherproof, as the ingress of water will decrease radio performance. If necessary, wrap the connection with weatherproofing tape.

Before installing a new system, it is preferable to bench test the complete system as configuration problems are easier to recognise when the system units are close together.

Following installation, poor communications can be caused by:

- Incorrectly installed antennas
- Radio interference on the same channel
- Obstructions in the radio path
- Radio path too long

If the radio path is a problem, higher performance antennas or a higher mounting point for the antenna may help. Alternately, use a 905U module as a repeater.

The foldout sheet *905U-K Installation Guide* is included with the product, with more detailed information in the following sections:

3.1 How to mount the 905U-K

The 905U-K module is housed in an IP66 weatherproof aluminium enclosure. To mount the 905U-K, remove the four screws in the top plate, and carefully remove the cover. The two mounting holes should now be visible.

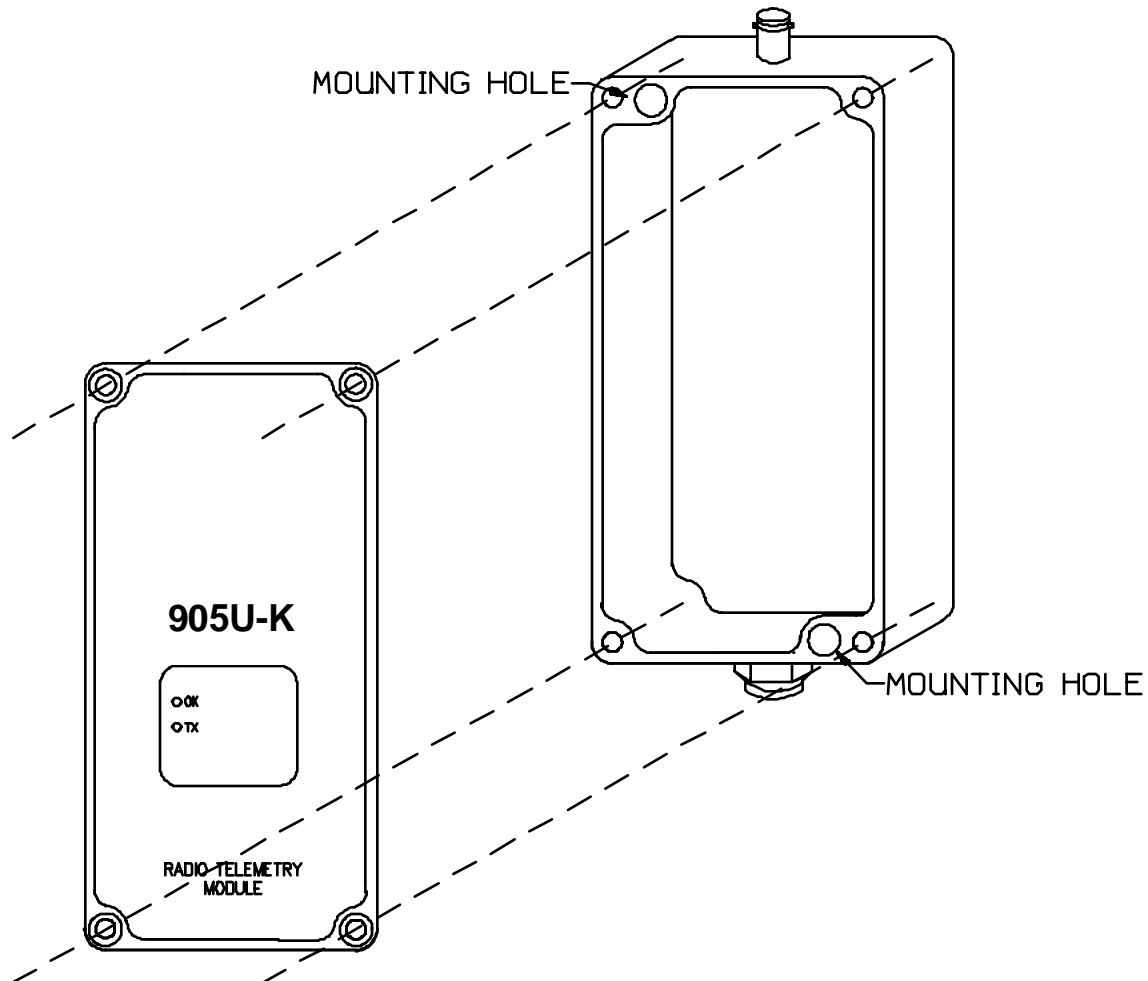

It is important to effectively earth the unit to help prevent radio noise and static electricity damage. The preferred method is to earth the module using the mounting screws to connect to an earthed surface. If this is not possible, use an earth lug in the mounting screw connection and secure the other end of the wire to a good earth.

3.2 Antenna Installation

The 905U-K module will operate reliably over large distances. The distance that may be reliably achieved will vary with each application - depending on the type and location of antennas, the degree of radio interference, and obstructions (such as hills or trees) to the radio path. Where it is not possible to achieve reliable communications, a 905U module may be used to receive the message and re-transmit it. This module is referred to as a repeater. This module may also have input/output (I/O) signals connected to it and form part of the I/O network.

An antenna must be connected to each 905U-K module using the SMA connector that protrudes through the top of the enclosure.

To achieve the maximum transmission distance, the antennas should be raised above intermediate obstructions so the radio path is true “line of sight”. Because of the curvature of the earth, each antenna will need to be elevated at least 5 metres above ground for paths greater than 5 km (3 miles). The modules will operate reliably with some obstruction of the radio path, however the reliable radio range is decreased. Obstructions that are close to either antenna will have more of a blocking effect than obstructions in the middle of the radio path.

Small whip antennas may be connected directly to the 905U-K module. Other antennas may be connected to the module via 50 ohm coaxial cable (eg RG58 or RG213) terminated with a male BNC connector. Connections between the antenna and coaxial cable should be carefully taped to prevent ingress of moisture.

Moisture ingress in the coaxial cable is a common cause for problems with radio systems, as it greatly increases the radio losses. We recommend that the connection be taped, firstly with a layer of PVC Tape, then with a vulcanising tape such as “3M 23 tape”, and finally with another layer of PVC UV Stabilised insulating tape. The first layer of tape allows the joint to be easily inspected when trouble shooting as the vulcanising seal can be easily removed.

The higher the antenna is mounted, the greater the transmission range will be, however as the length of coaxial cable increases so do cable losses. There are several types of antennas suitable for use on unlicensed frequency channels. It is important that the antenna is chosen carefully to avoid contravening the maximum power limit on the unlicensed channel - if in doubt refer to an authorised service provider.

Connections between the antenna and coaxial cable should be carefully taped to prevent ingress of moisture. Moisture in the coaxial cable is a common cause for problems with radio systems, as it greatly increases the radio losses. We recommend that the connection be taped with a vulcanising tape such as “3M 23 tape”, with a secondary layer of PVC insulating tape.

Where antennas are mounted on elevated masts, the masts should be effectively earthed to avoid lightning surges. Surge suppression devices are recommended if lightning surge problems are likely in the installation area. If the antenna is not already shielded from lightning strike by an adjacent earthed structure, a lightning rod may be installed above the antenna to provide shielding.

The available antennas to be used with the 905U-K units are:

CFD890EL	0 dBi Dipole antenna with 15’ of low loss RG-58 and SMA connector
SG900EL	5dBi Colinear omni-directional antenna with N-type connector (use CC10/900 or CC10/900)
SG900-6	8dBi Colinear omni-directional antenna with N-type connector (use CC10/900 or CC10/900)
YU6/900	10dBi Yagi directional antenna with N-type connector (use CC20/900 only)

The available accessory cables for use with the 905U-K units are:

CC10/900	33’ low loss RG-58 cable, 3dB loss
CC20/900	66’ low loss RG-58 cable, 6dB loss

Dipole and Colinear antennas.

A unity gain dipole is the normal antenna for use on unlicensed channels. As it does not provide any gain, then the power transmitted from the antenna will be the same as the power out of the module. Dipole antennas are only available with a 15 feet of coaxial cable and SMA connector for mounting away from the 905U-K module. Dipole antennas should be mounted vertically, at least 1 metre away from a wall or mast.

For longer, more **marginal** radio paths higher gain colinear antennas can be used. These must be used with either CC10/900 or CC20/900 cable.

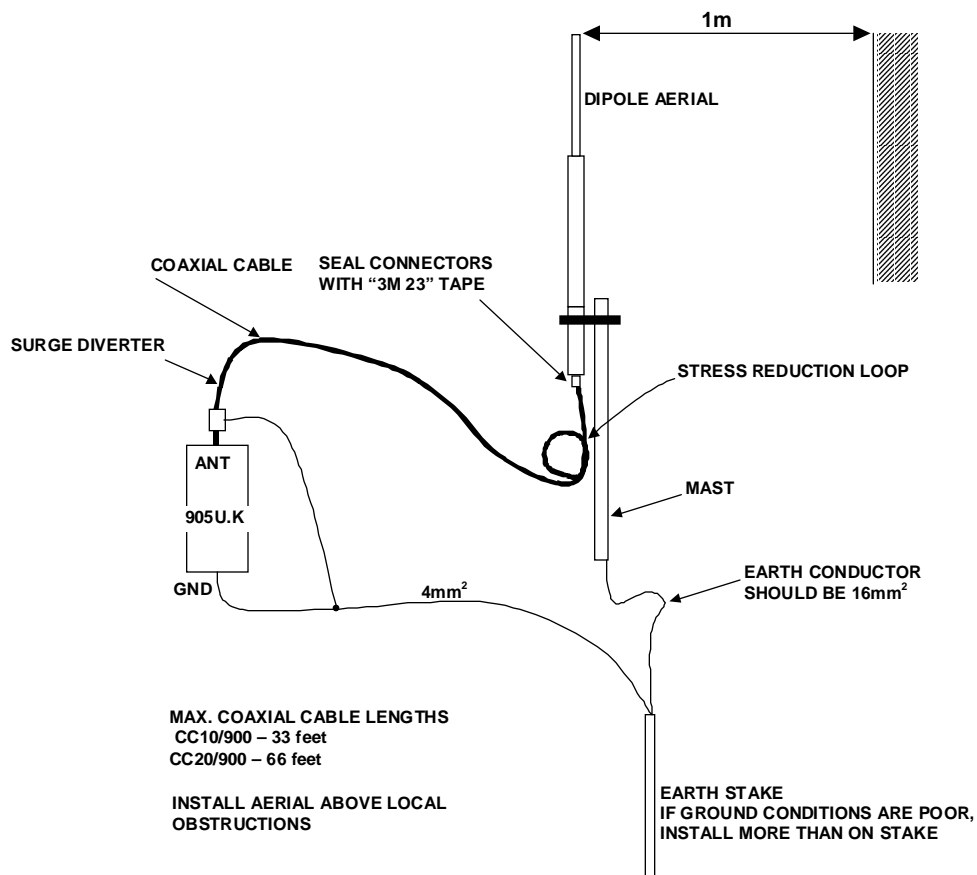

The 905U-K normally produces 1.0 Watt of radio power when an external DC power supply is used. FCC regulations allow this power may be boosted to a maximum 4.0W by using a higher gain antennas. These higher gain antennas may also be used to compensate for coaxial cable loss. The losses are 3dB for every 10m of RG58 cellfoil. If 10m of RG58 cable is used on a marginal radio path, then a higher gain antenna may be used to cancel the losses in the cable and boost the transmitted power back to the maximum level.

YAGI antenna.

YAGI antennas must only be used with a cable loss of 5dB or greater so the overall system gain is less than 6dB. So they should only be used with a CC20/900 cable.

YAGI antennas are directional. That is, they have positive gain to the front of the antenna, but negative gain in other directions. Hence YAGI antennas are normally installed with the central beam vertical and must be pointed in the direction of transmission to benefit from the

gain of the antenna. Also note that YAGI antennas normally have a drain hole on the folded element - the drain hole should be located on the bottom of the installed antenna.

The YAGI antennas may be installed with the elements in a vertical plane (vertically polarised) or in a horizontal plane (horizontally polarised). For a two station installation, with both modules using YAGI antennas, horizontal polarisation is recommended. If there are more than two 905U-K modules transmitting to a common 905U module, or there is dipole or colinear used in the system, then the YAGI antennas should have vertical polarisation.

3.3 Connection Plug

External power and input signals are connected using a weatherproof plug, provided with the module. For the 905U-K a 7 pin plug is used. The plug needs to be assembled as per the following diagram.

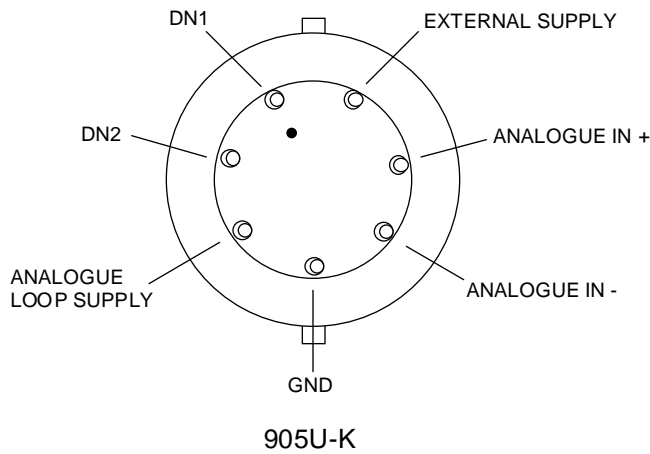
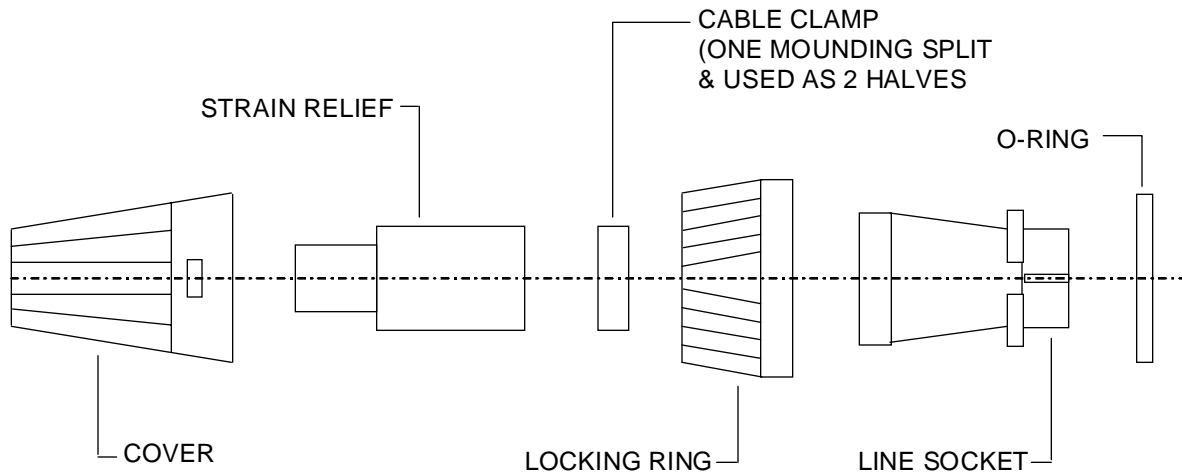

NOTE: VIEW FROM SOLDER CONNECTION SIDE OF PLUG

3.4 Power Supply Installation

3.4.1 External Power

The 905U-K module will accept an external supply of 5.4 - 30.0 volts DC. An external supply with a battery and battery charger is suitable. Negatively grounded or floating supplies are acceptable, however **positively grounded supplies must not be connected**. The 905U-K connects the negative supply (COMMON) to “ground”. Connect the external supply as per the following diagram.

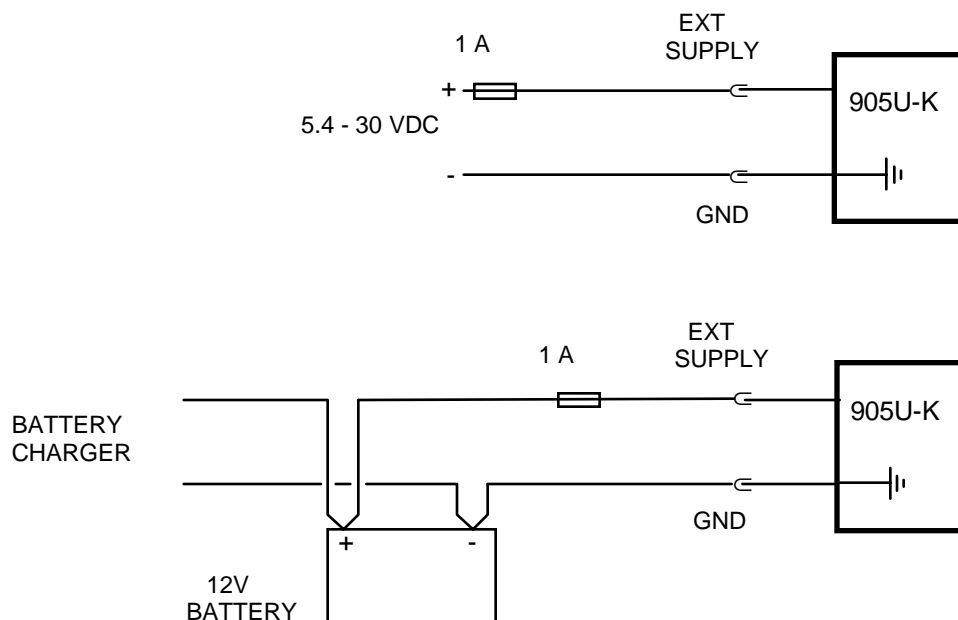

Configuration of the module will **not be lost** when batteries are removed, so no special procedure is required when changing batteries of the same type.

3.5 Input Signal Connections

3.5.1 Digital/Pulse Inputs

Digital and pulse inputs share the same input channel. Each input is connected between the DIN connector and COMMON. Inputs can be voltage-free contacts, NPN transistor switches, or a voltage signal (ON < 1 volt DC, OFF > 2 volts DC).

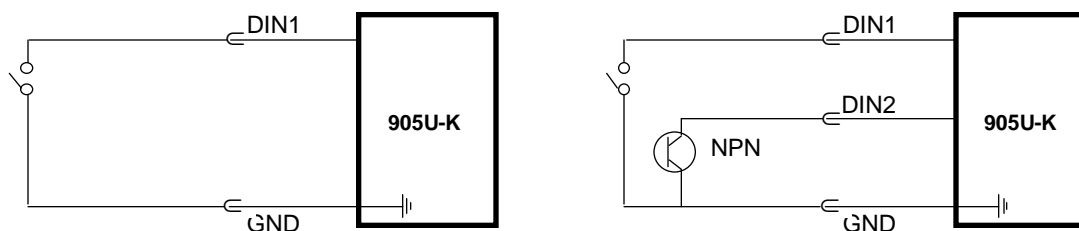

Inputs can be voltage free contact or open-collector transistor

Inputs do not have any surge protection. If the sensor or switch is mounted a long way from the 905U-K module, external isolation such as a relay may be required for surge protection.

3.5.2 Shaft Encoder Connections

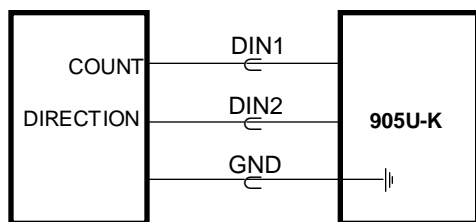

INCREMENTAL SHAFT ENCODER

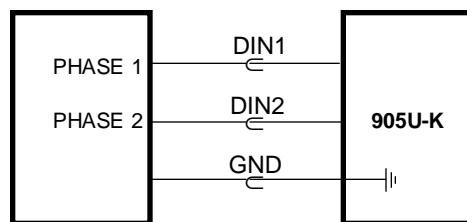

QUADRATURE SHAFT ENCODER

Analogue input The analogue input has a positive and a negative terminal, and may be placed at any point in the current loop, as long as neither input rises more than 24V above COMMON or ground. A 24 VDC 30mA supply is provided for powering analogue loops. The analogue loop may be powered from the internal supply or may be externally powered.

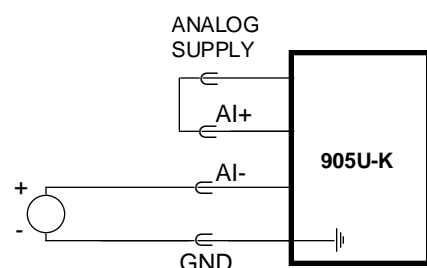

LOOP POWERED TRANSDUCER

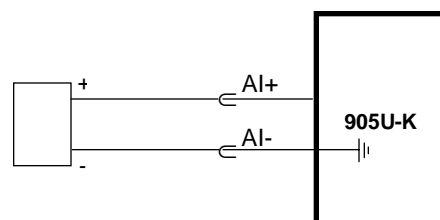

EXT POWERED TRANSDUCER

Shielded cable is recommended for analogue input loops to minimise induced noise and radio frequency interference (RFI). The shield of the cable must be connected to earth at one end of the cable only. Each input has a loop resistance of 150Ω and zener diode protection against overvoltage and reverse voltage. Additional surge protection is recommended in high electrical noise environments, or if the analogue signal cable runs for a long distance underground before connecting to the 905U-K module.

3.5.3 RS232 serial port

An RS232 port is provided for connection of a PC for configuration and diagnostics. To access the serial port DB9 connector, remove the front cover from the module by unscrewing the four screws in the front panel. The serial port is a 9 pin DB9 male and provides for connection to a terminal or to a PC for configuration, field testing and for factory testing. Communication is via standard RS-232 signals. The 905U-K is configured as DCE equipment with the pinout detailed below.

Pin	Name	Dirn	Function
1	-	-	Not Used.
2	RD	Out	Receive Data - Serial Data Output (High = 0, Low = 1)
3	TD	In	Transmit Data - Serial Data Input (High = 0, Low = 1)
4	DTR	In	Data Terminal Ready - used by 905U-K as a "wake-up" signal
5	SG	-	Signal Ground
6	-	-	Not Used.
7	-	-	Not Used.
8	-	-	Not Used.
9	-	-	Not Used.

The DTR signal must be connected to the 905U-K to enable communications and “wake up” the microprocessor. This means that the DTR wire must be connected - the PC does not need to control DTR. When communications is established, the green LED will light continuously.

The serial port communicates at a baud rate of 9600 baud, 8 bits, no parity, one stop bit.

An example cable drawing for connection to a personal computer is detailed below:

E505 DB9 (M) Connector

Computer DB9 (F) Connector



4 CONFIGURATION

The 905U-K module is configured by creating a configuration file on a PC and downloading to the 905U-K via the RS232 serial port. You will require the configuration software, and a serial cable - refer to the previous section.

The configuration software is supplied as "free-ware" on the Product Catalog CD supplied with each order. The configuration software for the 905U-K is the same as the software for the 905U. Please read section 4.3 of the 905U User Manual before proceeding further.

Setup the project name and system address as per the 905U manual. Enter the "units" as per the manual. Select "905U-K" as the unit type for 905U-K modules.

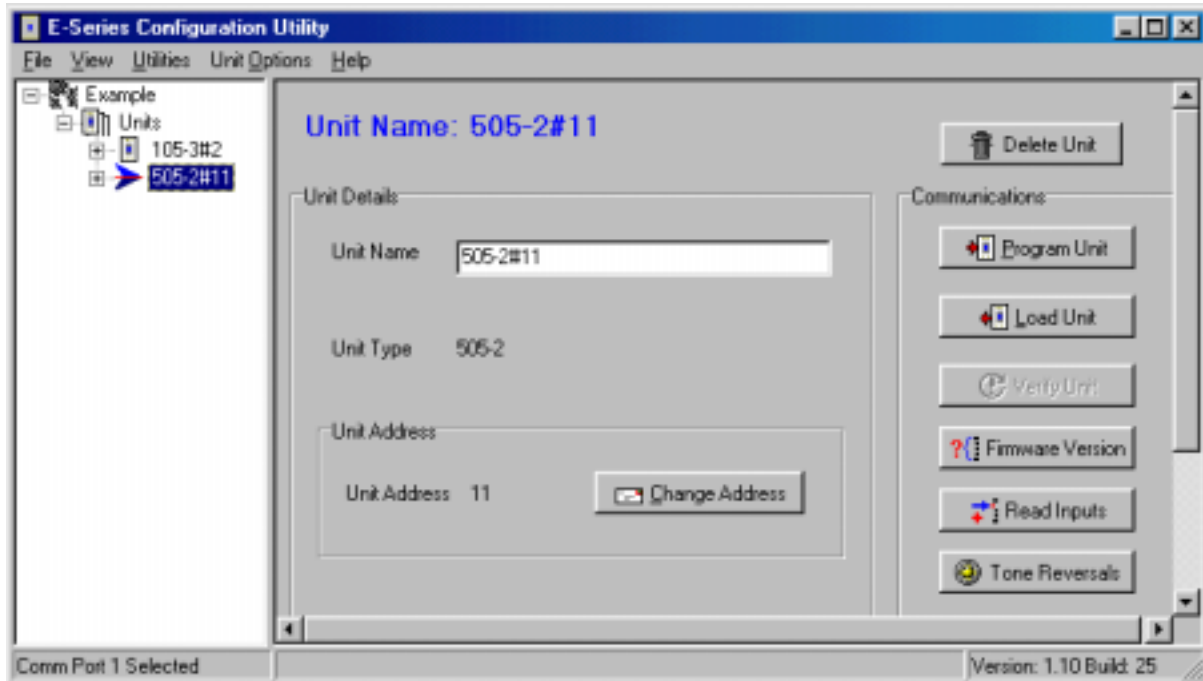

Each 905U-K has a unit address and a secondary address. Up to eight 905U-K modules can use the same system address. If you enter the same unit address for more than one 905U-K, the configuration software will automatically increase the secondary address. The default description of a 905U-K module is 505-2#10_1 where 10 is the unit address and 1 is the secondary address. If a unit address of 10 is chosen for another 905U-K module, it will have a default description of 505-2#10_2. For small systems, select a unique unit address for each 905U-K module.

4.1 I/O Mapping

Enter I/O mappings as per the 905U manual.

In the following example, a digital input at a 905U-K is mapped to DO1 of 905U#13. The analogue inout of the 905U-K is mapped to AO2 of the same module.

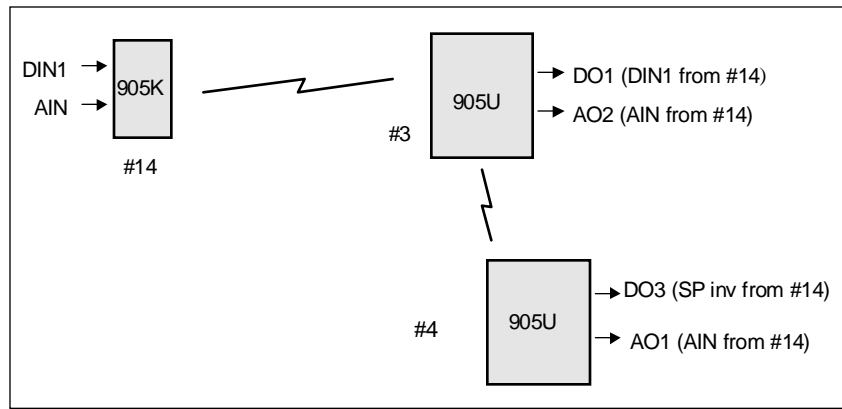

The setpoint status of the 905U-K is mapped (inverted) to DO3 of 905U#14, using 905U#13 as a repeater. The 905U-K AI is also mapped to AO1 of this module. That is, the AI is mapped twice.

The mapping configuration for the 905U-K would be :

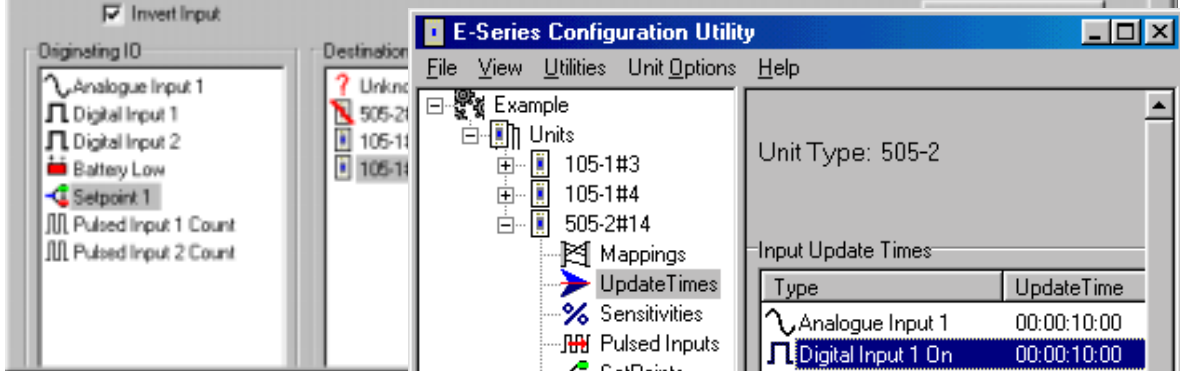
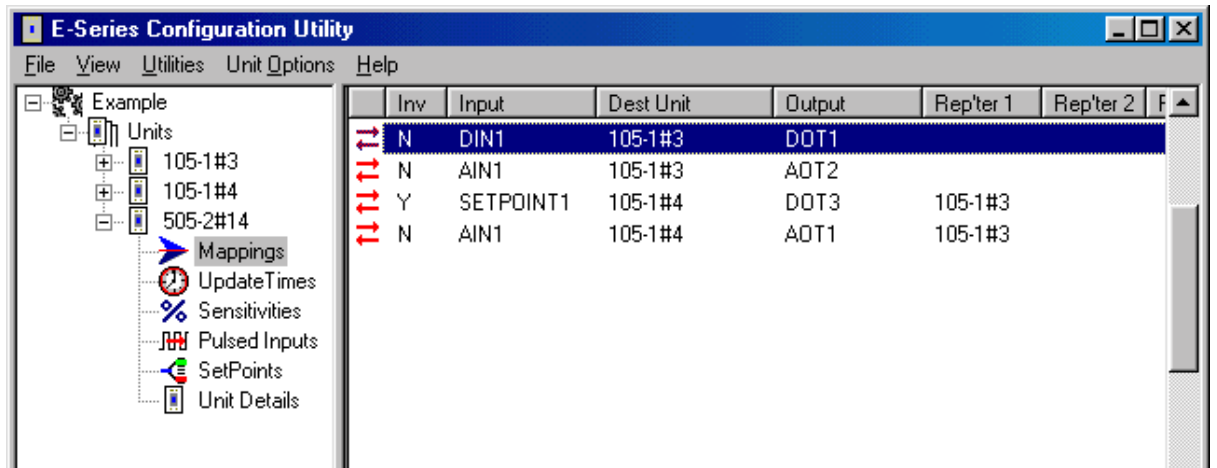

4.2 Update Transmission Times

Each input signal has an update time. If a change has not

occurred for this input within this time, then a transmission is set for this input after the update time has expired. Each input signal has its own timer - when a transmission occurs for this input (either a change transmission or an update transmission) the timer is reset to zero. If the timer reaches the Update Time value, then a update transmission occurs.

Digital inputs (both external inputs and internal) have a separate update time for their "off" state and "on" state. This allows the input to be reported differently depending on its state. If the digital input is an alarm, then a user may wish the input to be updated more frequently when in the alarm state than when not in the alarm state. The analogue input and pulsed inputs only have one update time value.

Valid values are 10 seconds to 120 hours. If less than 10 seconds is entered, the value will default to 10 seconds. If zero is entered, then there will be no update transmissions for this input.

4.3 Digital Inputs

Apart from update times, the only configurable parameter for digital inputs is the paralysis time. This parameter can be changed by selecting the Unit details option.

If a value of zero is entered, then there is no paralysis time.

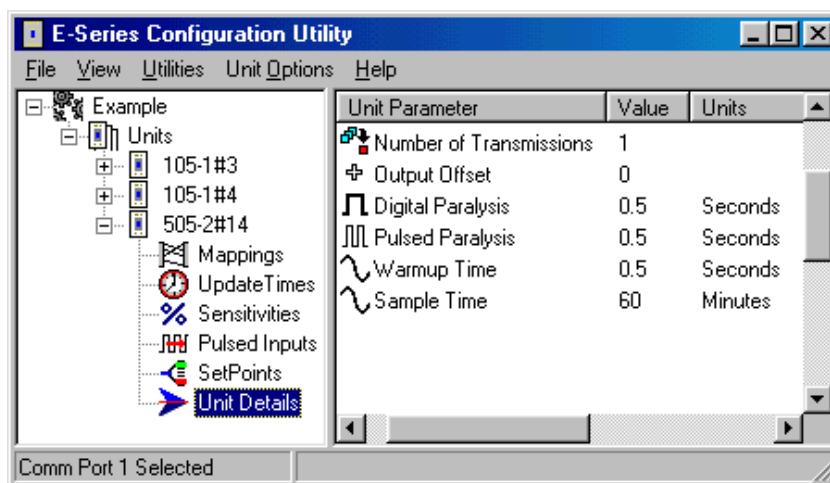

4.4 Analogue Input

There are three parameters which may be adjusted for the analogue input.

The **change sensitivity** is the amount of change since the last transmission which will trigger another transmission for this input. For example, if the last transmitted value of the input was 55.0%, and the sensitivity is 1.2%, then another transmission will occur if the measured input value is less than 53.8% or more than 56.2%. If change messages are not required, then a sensitivity of 100% should be selected.

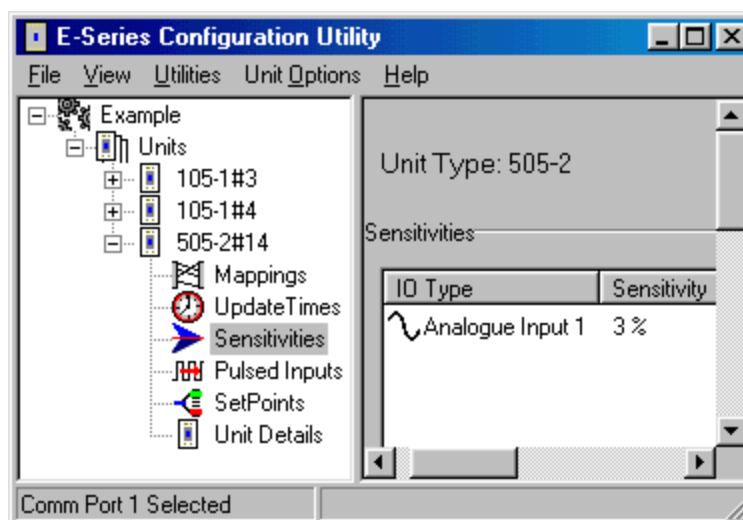

Each 1% corresponds to 0.2mA of signal. The sensitivity should be set to be greater than the natural "signal noise" of the analogue input. For example, if there is a signal oscillation of 1% on the input, then a sensitivity of less than 1% will result in continuous change transmissions which could overload the radio channel.

The **sample time** is the time period for each analogue input measurement.

Between measurements, the 905U-K will operate in "sleep" mode. When the sample time has expired, the 905U-K will turn on the analogue loop power supply. After a further time, called the **warmup time**, the 905U-K will make a measurement of the

input. The warmup time allows the transducer to stabilise and become accurate after the loop supply is turned on.

The sample time may be entered in minutes, between 1 and 30 000 minutes. If a zero value is entered, then the loop power supply will be always on. The warmup time may be entered in seconds between 1 and 127 seconds. If a zero value is entered, then an analogue measurement will be made as soon as the loop supply is turned on. If both the sample time and warmup time are set to zero, then an analogue measurement will be taken on every 905U-K cycle (every 0.5 sec).

4.5 Analog Setpoints

A high setpoint value and a low setpoint value may be entered. The internal setpoint status is determined by these values in comparison to the analogue input value. If the analogue input is less than the low setpoint, then the setpoint status is "on". If the analogue input is more than the high setpoint, then the setpoint status is "off". When the input is between the low and high setpoints, then the setpoint status remains unchanged.

The setpoint values may be set between 0 and 100% corresponding to 0mA and 20mA. The low

setpoint may be set to the same value as the high setpoint, however the low setpoint should not be set to a higher value than the high setpoint.

4.6 Pulse Inputs

There are several configurable parameters for pulse inputs. The debounce value can be adjusted from the Unit Details selection, as per Digital Inputs.

If either pulse input has an input rate of more than 10Hz, then the Fast Pulse Input option should be selected from the Pulsed Inputs selection.

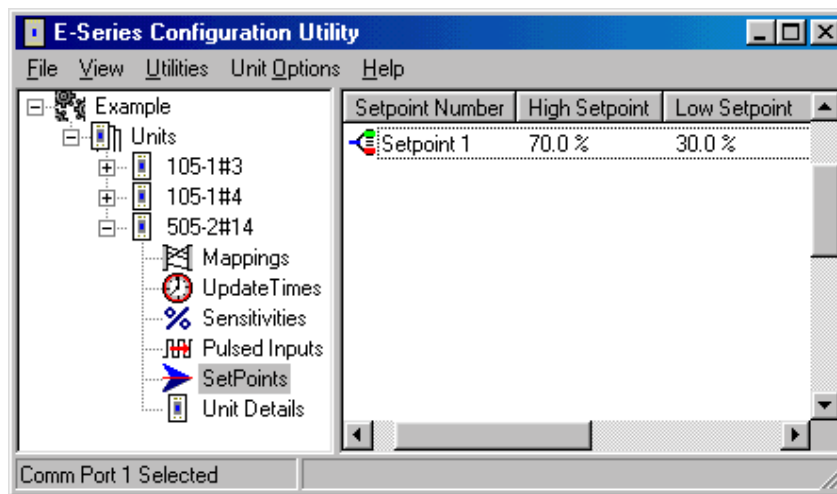
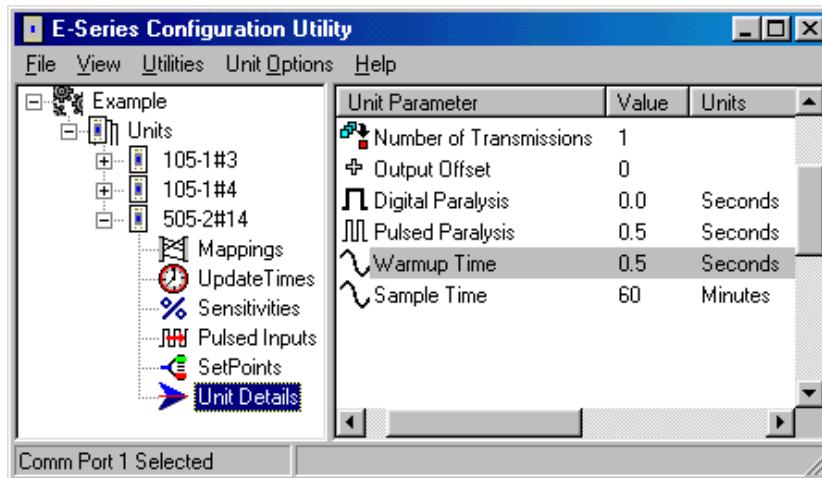

If the pulse inputs are connected to a shaft encoder (incremental or quadrature types), then the Shaft Encoder Inputs option should be selected.

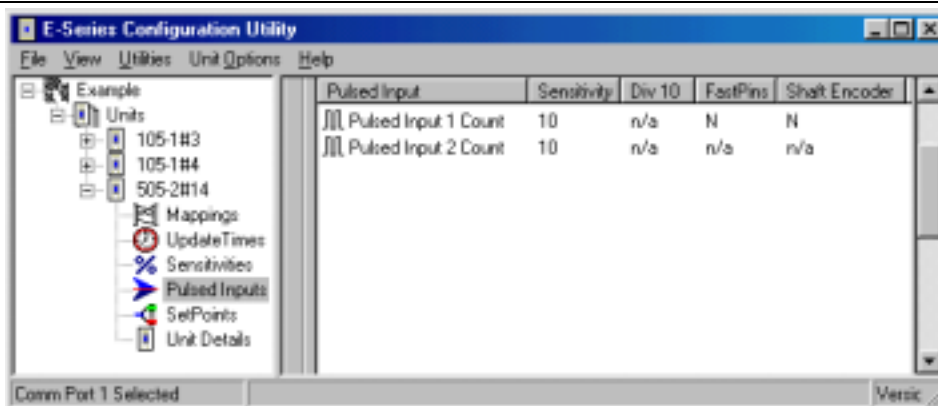

The pulse inputs also have a Sensitivity value. The pulse input sensitivity is the number of pulse increments since the last transmission to trigger another transmission. For example, if the pulse count at the last transmission for a pulse input was 1000, and the sensitivity value is 10, then another transmission will occur when the pulse count reaches 1010 (provided there has not been an update transmission during this period). The sensitivity values can be between 1 and 32000.

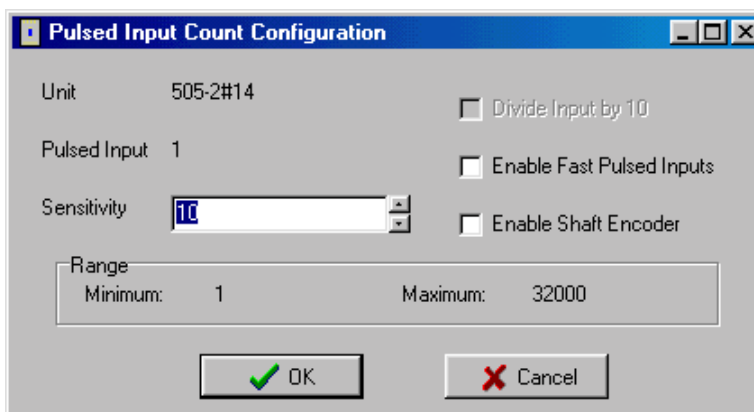

4.7 Number of Transmissions

This parameter allows you to select the number of transmissions for each message. For example, if 3 is selected, then each message will be transmitted three times. The time between each transmission will be a random time between 0.5 and 4 seconds. The valid choices for this option are 1 - 5.

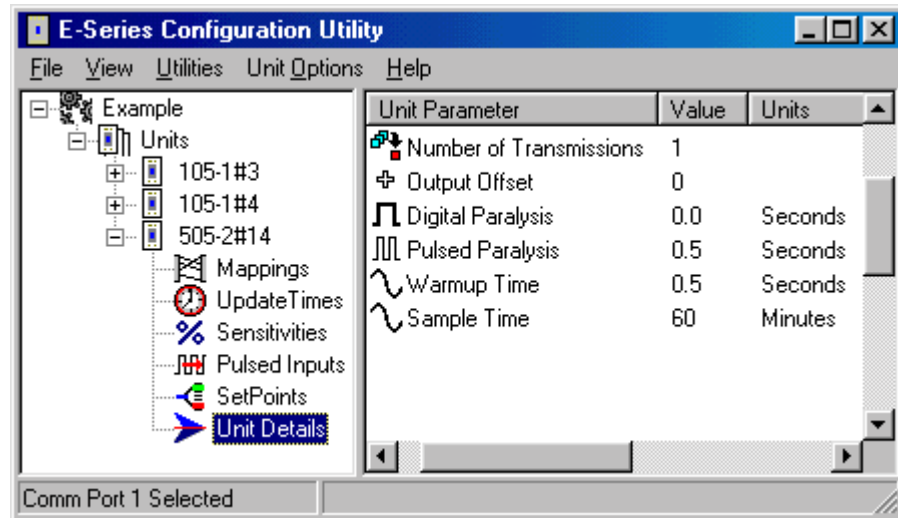

4.8 Programming Configurations to Modules

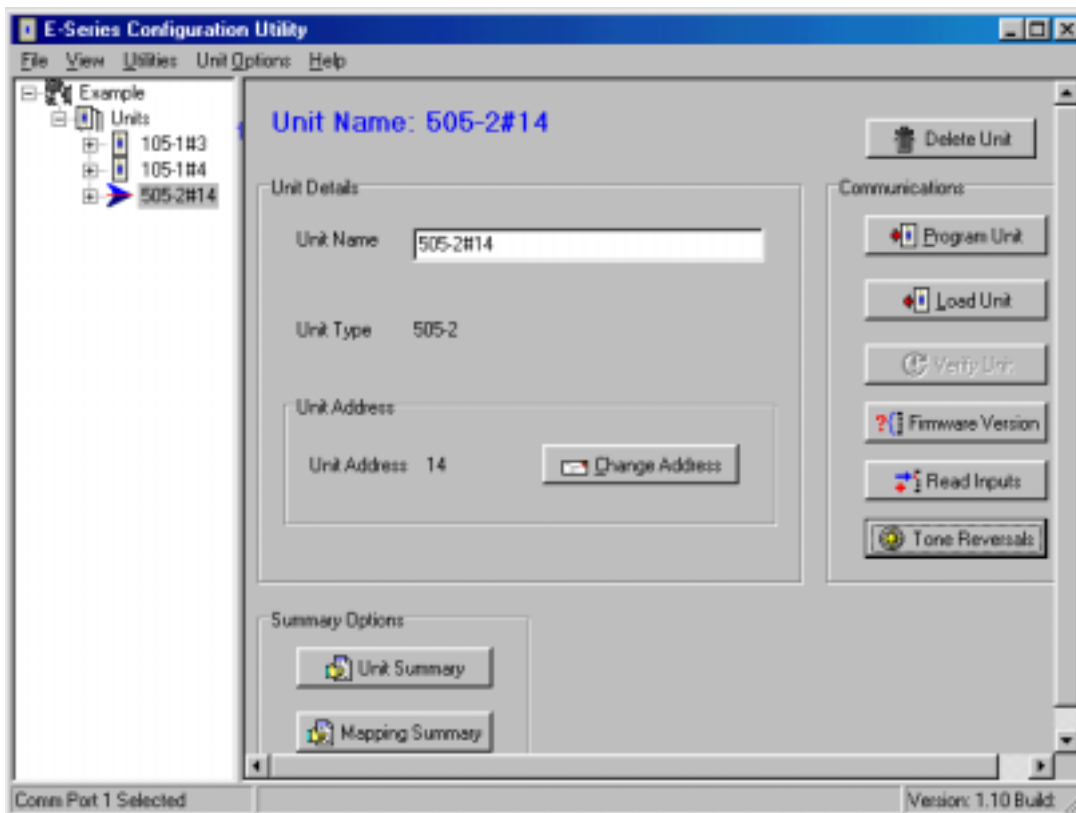

To programme a module :

- Connect the cable from the PC's serial port to the 905U-K serial port (see 3.5.4 for cable connections)
- From the Utilities menu, select "Serial Port Setup"
- Select the appropriate serial port (COM1 - COM4)

- Select the unit to be configured from the left-hand menu
- Click on the “Program Unit” button.

You will be asked to confirm if the module already has a different system or unit address.

Each module will need to be programmed individually.

4.9 Loading Configuration from a Module

Care should be taken when loading a configuration from a module. It is easy to lose the system address and unit address. We suggest that you first view the system address and unit address - you can do this via the “Unit Options” menu. Note these addresses before loading the configuration.

When you upload the configuration, the program will check if you want to load the addresses from the module. If you do not, then the system address and unit address will change.

4.10 Print Options

You can obtain a print-out of each module configuration. On each unit display, there are “Unit Summary” and “Mapping Summary” windows. Each of these will display a printable information page about that module. The Unit Summary page will display the user options configured, and the Mapping Summary will display the mappings entered for that unit.

The printer may be selected from the Printer Setup option in the File menu.

5 TROUBLESHOOTING

System Problems

Most problems relate to incorrect configuration, or radio path problems. Before installing the 905U-K module, "bench-test" its operation with the receiving 905U module alongside. If the 905U-K does not work properly in this test, it will not work properly installed. If problems are found, check the configuration.

If the bench-test is successful, however problems are experienced after installation, check the radio path (refer to the 105 User Manual for radio path testing).

The 905U-K provides the following diagnostic features which will help to identify problems.

LED Indicators.

Normally the green OK LED on the front panel will flash briefly every 10 seconds. When the OK LED extinguishes a sleepmode state is indicated conserving the 905U-K's battery power. If the OK LED does not flash, a flat battery condition or an internal failure may exist. If the 905U-K module is located outside, then it will be difficult to see when the LED indicators are on. Remove the front lid of the 905U-K to see the LED's better.

The yellow TX LED will flash whenever a radio transmission occurs.

Table of indicator conditions

INDICATOR	CONDITION	MEANING
OK LED ON	Flashes briefly	Normal Operation
OK LED OFF	Continuously	Battery Voltage low CPU failure
OK LED ON	Continuously	Analogue loop on Configuration cable connected
TX LED ON	Flashes briefly	Radio transmitting

Diagnostic Features

The configuration software provides some diagnostic features to help identify problems. To use these features, connect the 905U-K to a PC using a RS232 cable and run the configuration software. The OK LED will light continuously once the module is in configuration mode.

Note : The OK LED will generally not light continuously unless the cable is in place and the configuration software is running.

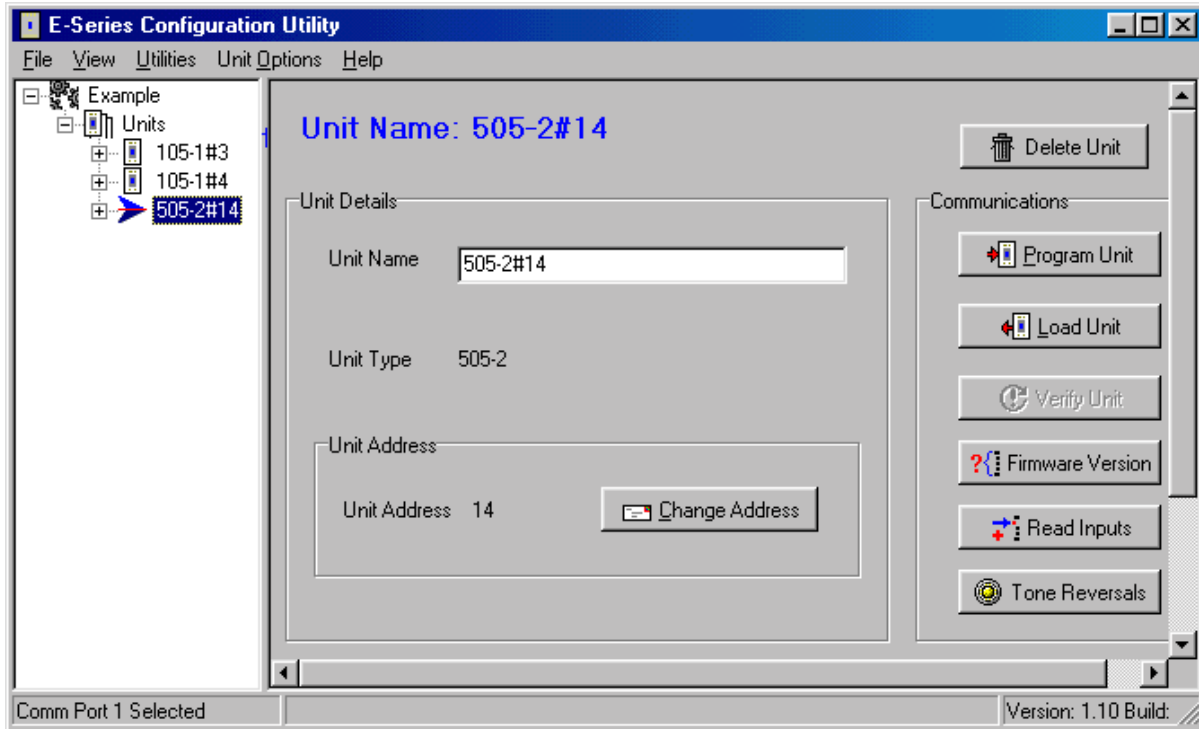

Read Inputs

This option provides a display of the measured input signals in the 905U-K, both internal and external. Digital inputs (internal and external) are displayed as "ON" or "OFF", the pulse input accumulated count values are displayed and the analogue input value is displayed in mA. The analogue input value is only updated when the configured analogue sample occurs.

The displayed values will only update when you select "Update".

Tone Reversals

This feature turns the radio transmitter on continuously for radio path testing. A series of 1 and 0 data bits is transmitted. This feature is not recommended for 905U-K-B versions as it will significantly reduce the life of the batteries.

To do radio path testing, refer to the 105 User Manual.

Firmware Version

The feature will display the firmware (software) version of the 905U-K module.

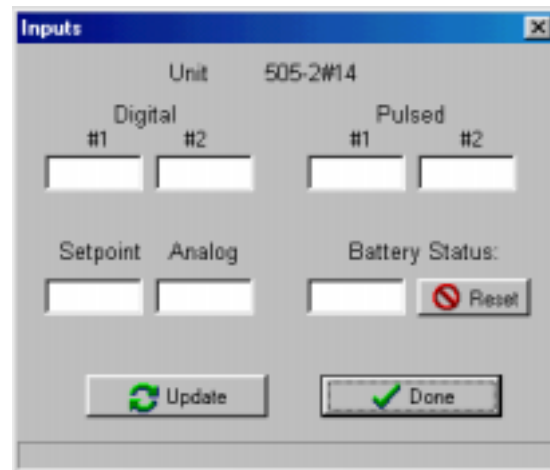

6 SPECIFICATIONS

General		
EMC approval	FCC Part 15	
Radio standards	USA FCC Part 15.247 Canada RSS-210	902 – 928 MHz, 1 Watt
Housing	160 x 64 x 36mm IP66	Industrial-grade painted aluminium
I/O & Power Connection	Weatherproof bayonet connector Female P/N: Conxall 6282-7SG-522	Suitable for 0.75 mm ² conductors Matching female part supplied with unit
LED indication	Transmit, Operation OK, Configuration mode, Reading analogue	
Operating Temperature	-40 to +55 degrees C	
Power Supply		
External Battery supply	5.4 - 30 V DC	Overvoltage, reverse power protected

Current Drain	<100 μ A 10mA + analogue loop current	“Sleep” mode Operating mode
Analogue loop supply	Included	24V DC Nominal, 30mA
Low Battery voltage status	Monitored	Can be transmitted to remote modules
Radio Transmitter		
Frequency	902 - 928 Mhz	250 kHz channel spacing
Transmit power	1 Watt	
Frequency Stability	+/- 10 kHz	
Expected line-of-sight range (subject to local conditions)	20 Miles +@ 4W EIRP 15 km @ 1W EIRP	USA/Canada Australia / New Zealand Range may be extended by using up to 5 intermediate 905U

		modules as repeaters,
Antenna Connector	SMA coaxial	
Serial Ports		
RS232 Port	DB9 female DCE	9600 baud, no parity, 8 data bits, 1 stop bit
Data transmission - digital inputs	On change-of-state + after update period elapsed	Update time configurable 10 secs - 5 days. Separate, faster update time may be configured when input is ON
Data transmission - pulse inputs	Transmitted as pulse count	Transmitted when count change exceeds configured amount, or on time elapsed since last transmission (configurable 10 secs - 5 days)
Data transmission - Up/down pulse input	2 pulse inputs may be configured to a single count	Suitable for quadrature or incremental shaft encoders.
Data transmission - analogue input	On change-of-state + after update period elapsed	Sample time configurable 10 secs - 5 days. Change of state sensitivity configurable 0.05 to 20mA. Update time configurable 10 secs - 5 days.
Protocol	Addressed data frame with 16 bit CRC, synchronous DFSK	Each transmission may be configured to be sent 1 - 5 times
Inputs		
Digital Inputs	2 inputs	Suitable for voltage free contacts or NPN transistor, input debounce 0.5 second
Pulse Inputs	2 inputs	Share digital inputs. Max rate 1000Hz, min. pulse width 3ms.
Analogue Input	One 0 - 20 mA (suitable for 4 - 20 mA, 0 - 10mA & 0 - 5 Volts)	“floating” differential input, common mode voltage 24V. 24V DC for powering external loops provided, 30 mA max. Resolution 12 bit, Accuracy < 0.1%. Transducer warm-up time configurable 1 - 255 seconds.
Analogue Input Setpoint		Configurable high & low setpoint may be transmitted to remote units, allowing set/reset of remote digital outputs

System Parameters		
Network Configurations	Max. number of 905U-K inputs is >20,000 if 905U-C modules are used as receivers.	905U-K is compatible with 905U radio telemetry units which may be used as repeaters, provision of outputs, or as network master unit to connect to PLC or PC
User Configuration		Windows Configuration Software
Diagnostics		
On board diagnostics	Automatic check on startup	Microprocessor operation OK
Diagnostics included in configuration software		Input status, test transmission signal