

RESET MONITOR

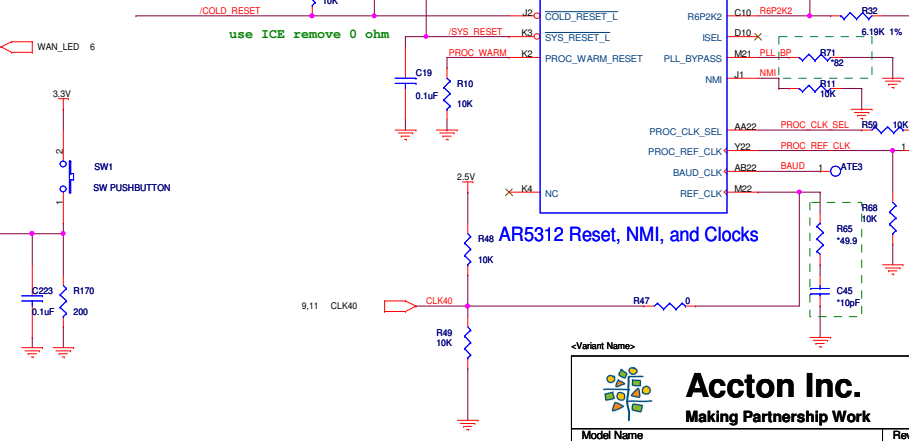

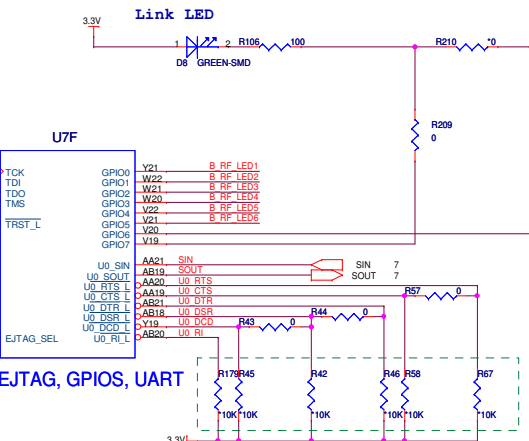

U7G
AR5312 Ground Pins

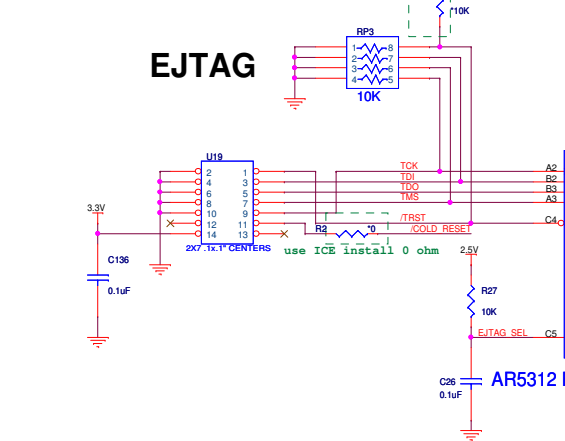
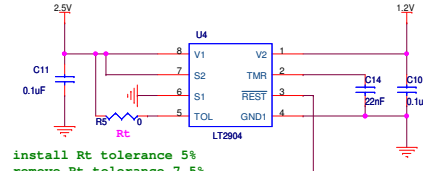
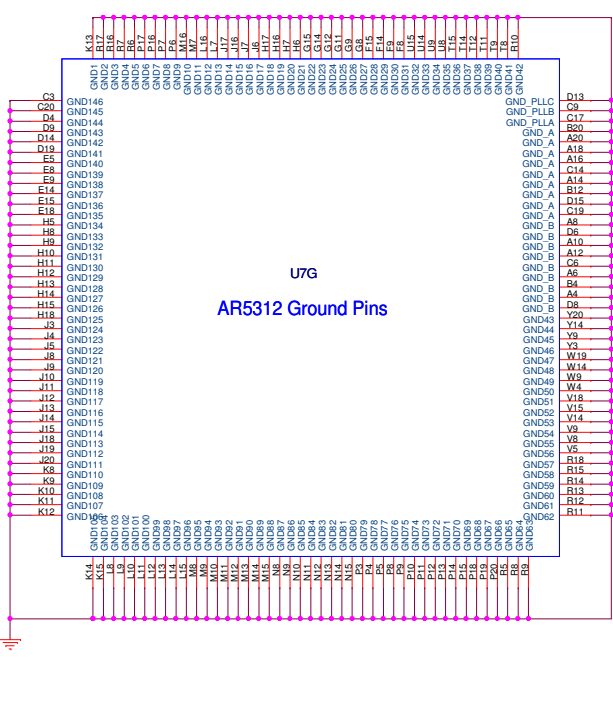
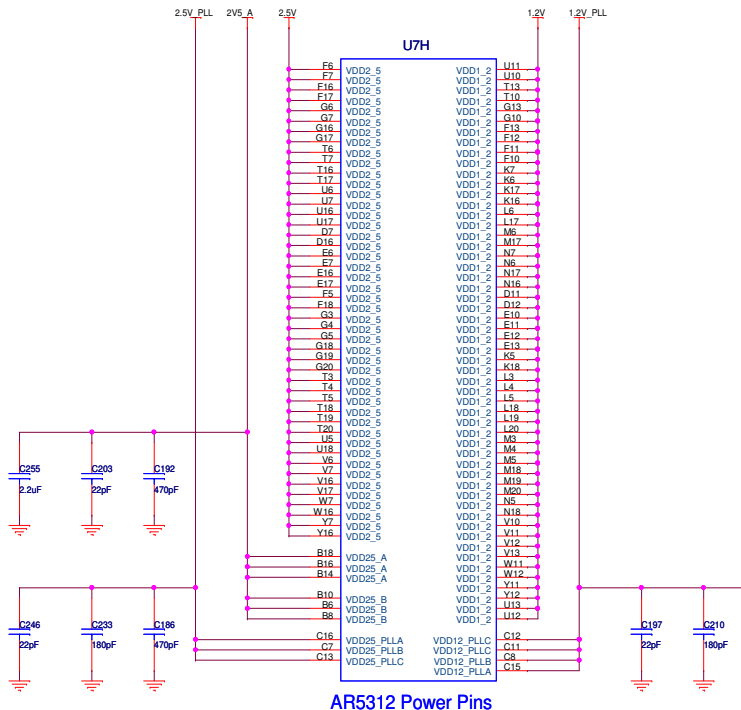

AR5312 Power Pins

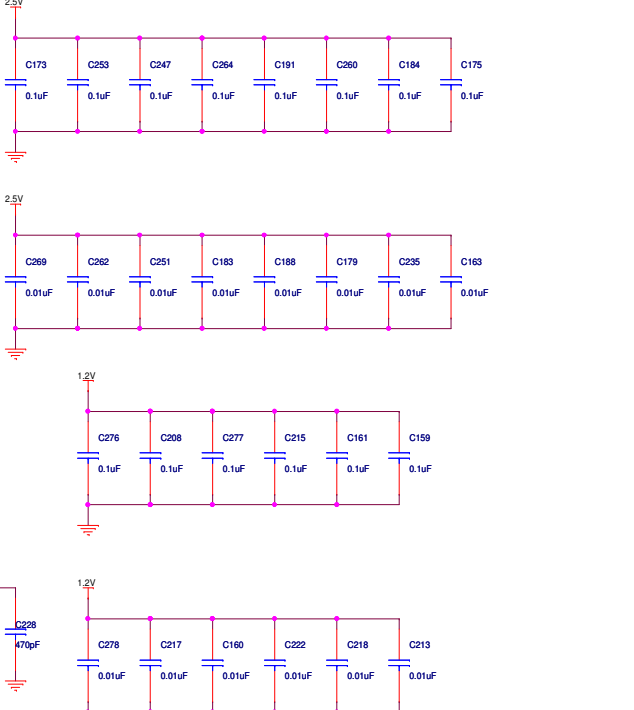

+1.2V SUPPLY

$$1.2V = V5 * (R2 + R1) / R2 = 0.8 * (11K + 22K) / 22K = 1.2V$$

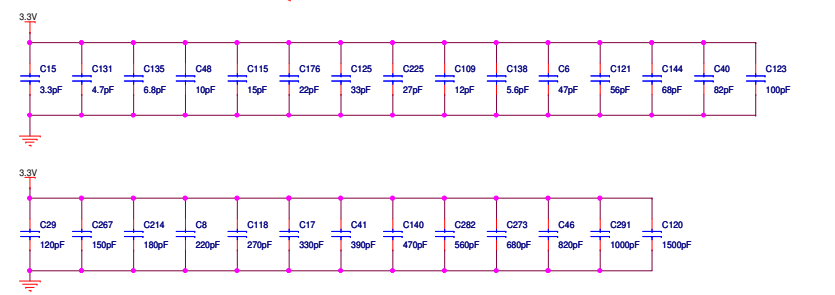
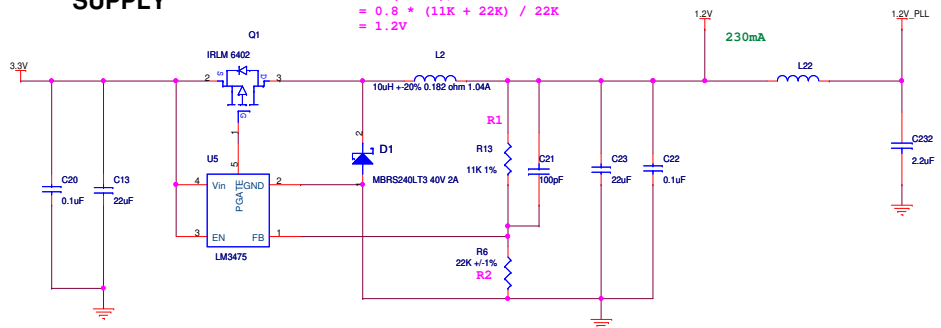

EMI

+2.5V SUPPLY

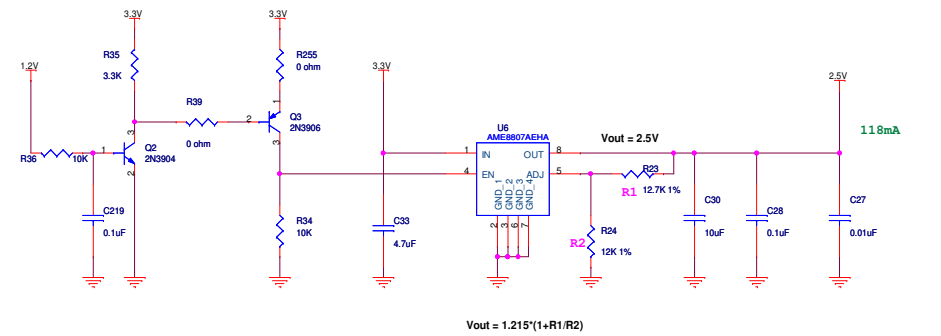

$$Vout = 1.215 * (1 + R1/R2)$$

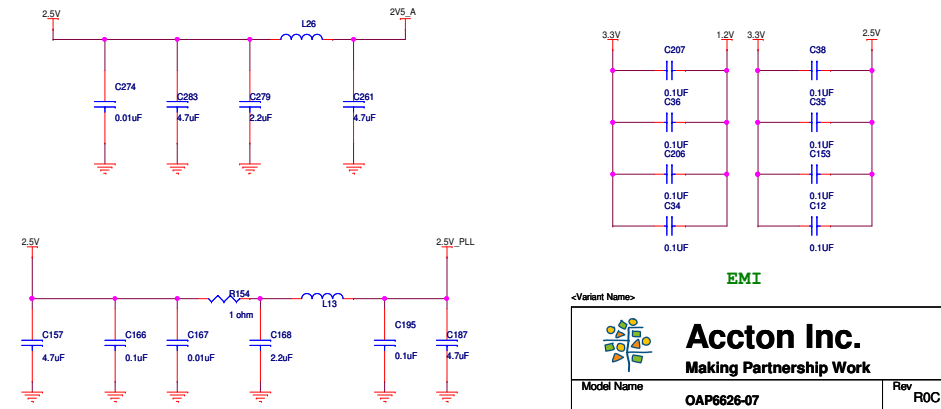

EMI

<Variant Name>

Accton Inc.
Making Partnership Work

Model Name	OAP626-07	Rev	ROC
Page Name	PowerPin_Vin_Digital Voltage	Engineer	<Engineer>
Date:	Thursday, January 10, 2006	Sheet	4 of 12

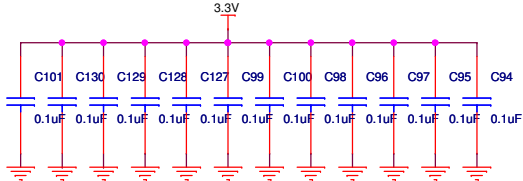
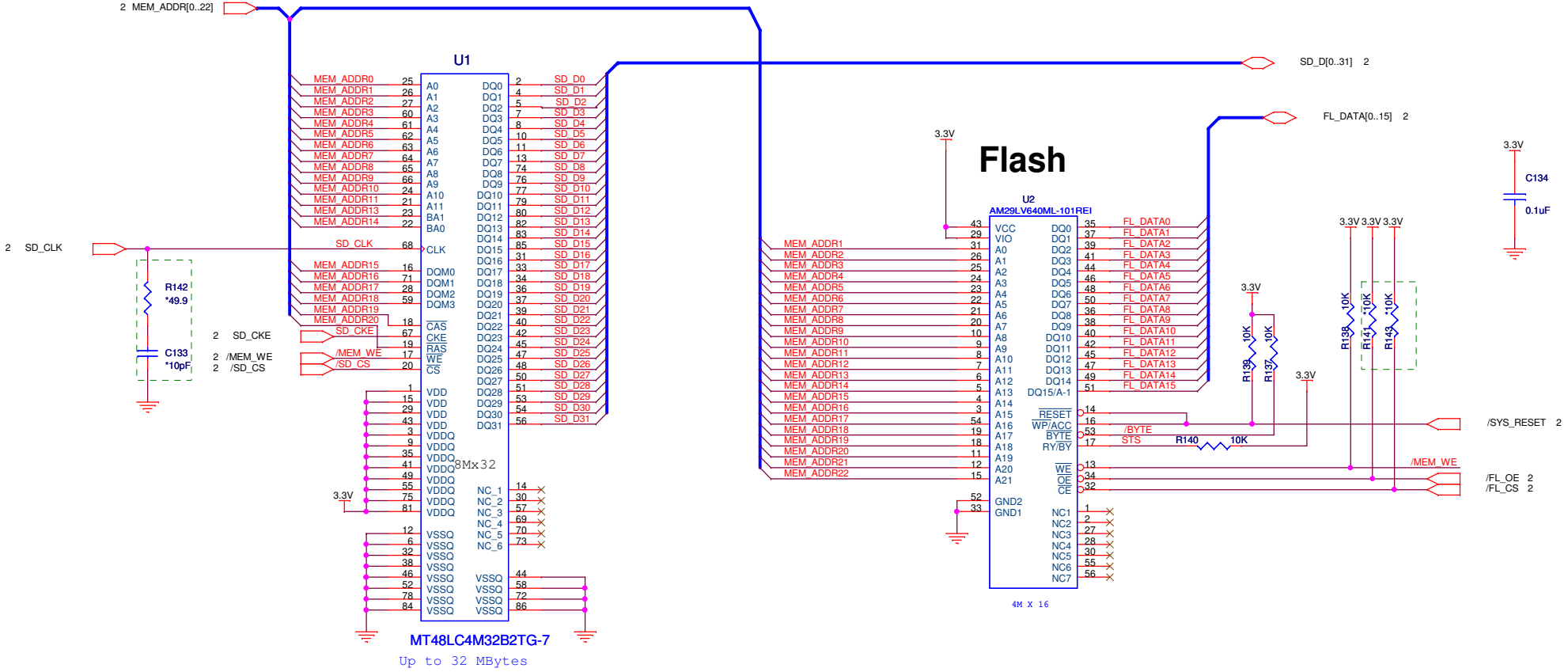

<Variant Name>

Accton Inc.
Making Partnership Work

Model Name	OAP6626-07	Rev	R0C
Size	Page Name	Engineer	
B	FLASH & DRAM		
Date:	Tuesday, January 10, 2006	Sheet	5 of 12

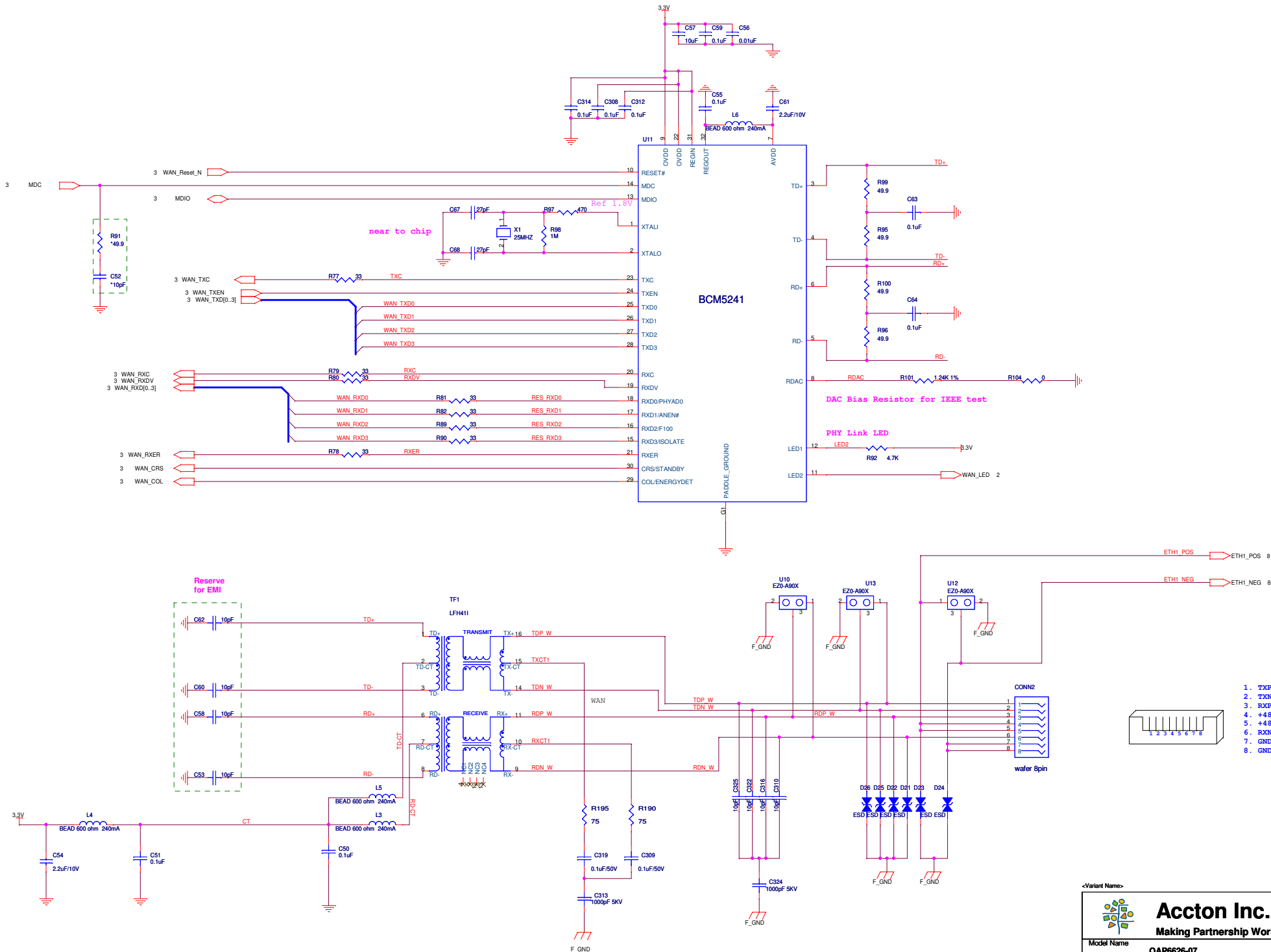

- 1. TXP
- 2. TXN
- 3. RXP
- 4. +4.5V
- 5. +4.8V
- 6. RXN
- 7. GND
- 8. GND

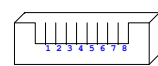

<Variant Name>

Accton Inc. Making Partnership Work		Rev R0C
Model Name	OAP626-07	
Size	Page Name	Engineer
C	WAN	<Engineer>
Date:	Tuesday, January 10, 2006	Sheet 6 of 12

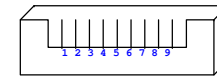
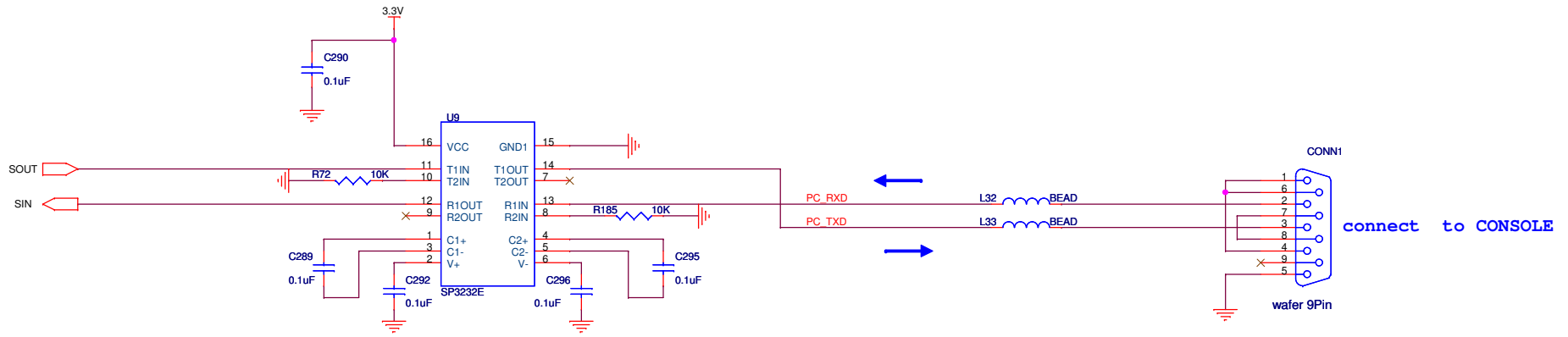

- 1. DCD
- 2. RXD
- 3. TXD
- 4. DTR
- 5. GND
- 6. DSR
- 7. RTS
- 8. CTS
- 9. RI

<Variant Name>



Accton Inc.
Making Partnership Work

Model Name		Rev
OAP6626-07		R0C
Size	Page Name	Engineer
B	Console	
Date:	Tuesday, January 10, 2006	Sheet 7 of 12

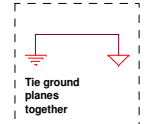
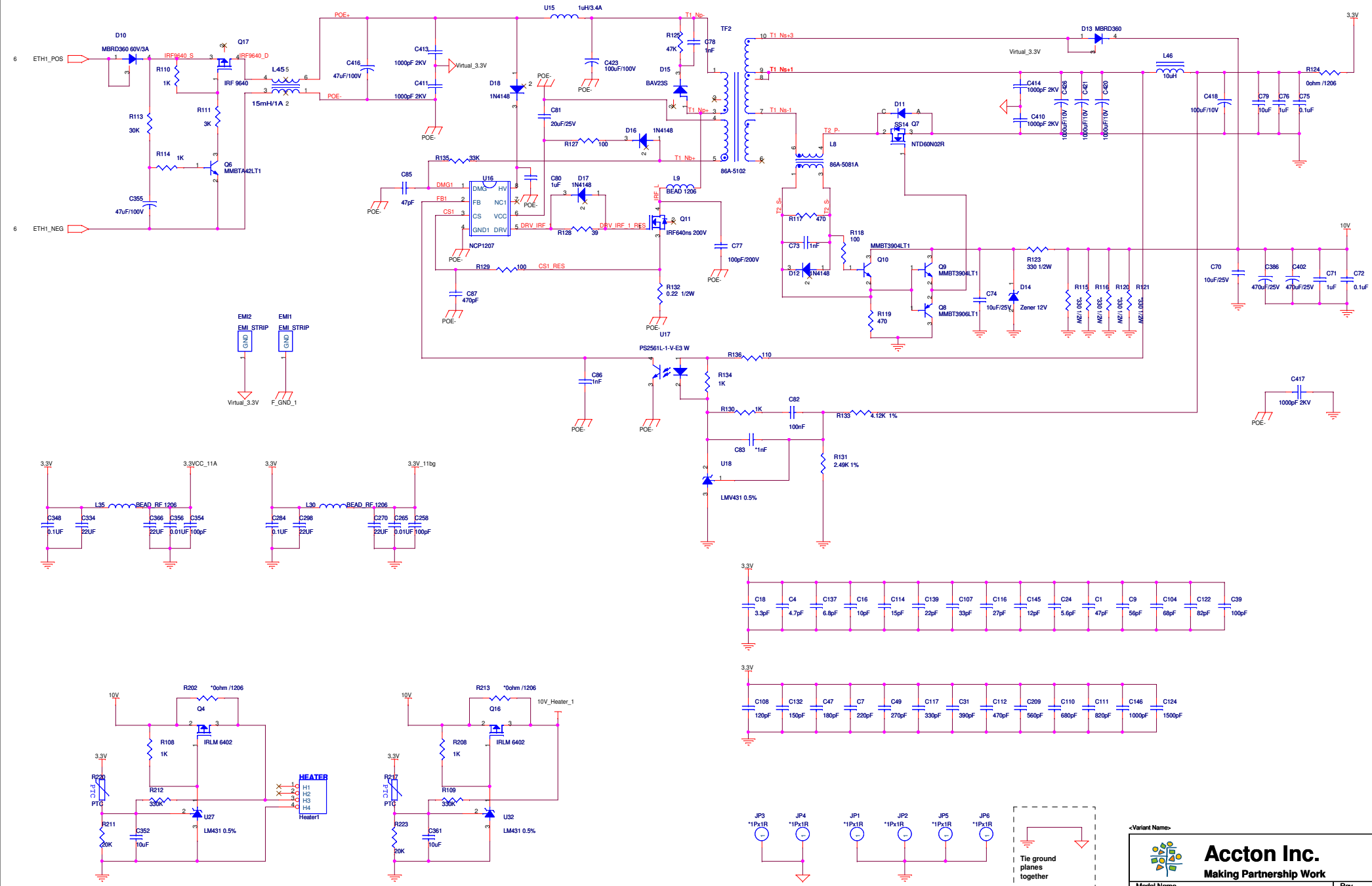

<Variant Name>

Accton Inc.
Making Partnership Work

Model Name	OAP6626-07	Rev	ROC
Size	Page Name	Engineer	
C			

Date: Tuesday, January 10, 2006 Sheet 8 of 12

