



FCC ID: O9C-WL561
Issued on Mar. 24, 2006

Report No.: FR493039-02-A

FCC TEST REPORT

CATEGORY : Mobile

PRODUCT NAME : 3Com Wireless 7760 11a/b/g POE Access Point

FCC ID. : O9C-WL561

FILING TYPE : Certification

BRAND NAME : 3Com

MODEL NAME : WL-561

APPLICANT : **3Com Corporation**

350 Campus drive, Marlboro Massachusetts 01752-3064,
USA

MANUFACTURER : **DONGGUAN G-COM COMPUTER CO., LTD.**

1st Row Yin Shan Rd., Yin Hwu Industrial Area, Qingxi Town,
Dong Guan City, Guang Dong, China

ISSUED BY : **SPORTON INTERNATIONAL INC.**

6F, No. 106, Sec. 1, Hsin Tai Wu Rd., His Chih, Taipei Hsien,
Taiwan, R.O.C.

Statements:

Only the test result of 802.11a part is shown in this test report.

The test result in this report refers exclusively to the presented test model / sample.

Without written approval of SPORTON International Inc., the test report shall not be reproduced except in full.

Certificate or Test Report could not be used by the applicant to claim the product endorsement by CNLA, NVLAP or any agency of U.S. government.

The test equipment used to perform the test are calibrated and traceable to NML/ROC or NIST/USA.



Lab Code: 200079-0

SPORTON International Inc.

TEL : 886-2-2696-2468

FAX : 886-2-2696-2255



Table of Contents

History of this test report..... ii

CERTIFICATE OF COMPLIANCE..... iii

1. General Description of Equipment under Test..... 1

 1.1. Applicant 1

 1.2. Manufacturer 1

 1.3. Basic Description of Equipment under Test 1

 1.4. Features of Equipment under Test 1

 1.5. Antenna Description 2

 1.6. Table for Carrier Frequencies 2

 1.7. Table for Maximum Conducted Output Power 3

2. Test Configuration of the Equipment under Test..... 4

 2.1. Connection Diagram of Test System 4

 2.2. The Test Mode Description 5

 2.3. Description of Test Supporting Units 5

3. General Information of Test..... 6

 3.1. Test Facility 6

 3.2. Test Conditions 6

 3.3. Standards for Methods of Measurement 6

 3.4. DoC Statement 6

 3.5. Frequency Range Investigated 6

 3.6. Test Distance 6

 3.7. Test Software 6

4. List of Measurements..... 7

 4.1. Summary of the Test Results 7

5. Test Result 8

 5.1. Test of 26dB Spectrum Bandwidth 8

 5.2. Test of Maximum Conducted Output Power 18

 5.3. Test of Peak Power Spectral Density 38

 5.4. Ratio of the Peak Excursion 58

 5.5. Test of Band Edges Emission 68

 5.6. Test of Frequency Stability 88

 5.7. Test of AC Power Line Conducted Emission 90

 5.8. Test of Spurious Radiated Emission 93

 5.9. Antenna Requirements 162

 5.10. RF Exposure 163

6. List of Measuring Equipments Used 169

Appendix A. Photographs of EUT..... A1 ~ A43



CERTIFICATE OF COMPLIANCE

with

47 CFR FCC Part 15 Subpart C (Section 15.407)

PRODUCT NAME : 3Com Wireless 7760 11a/b/g POE Access Point

BRAND NAME : 3Com

MODEL NAME : WL-561

APPLICANT : **3Com Corporation**

350 Campus drive, Marlboro Massachusetts 01752-3064,
USA

MANUFACTURER : **DONGGUAN G-COM COMPUTER CO., LTD.**

1st Row Yin Shan Rd., Yin Hwu Industrial Area, Qingxi Town,
Dong Guan City, Guang Dong, China

I **HEREBY** CERTIFY THAT:

The measurements shown in this test report were made in accordance with the procedures given in ANSI C63.4 - 2003 and all test are performed according to 47 CFR FCC Part 15. Testing was carried out on Nov. 03, 2004 at SPORTON International Inc. LAB.

A handwritten signature in blue ink, appearing to read 'Wayne Hsu', is written over a horizontal line.

Wayne Hsu / Supervisor
Sporton International Inc.



1. General Description of Equipment under Test

1.1. Applicant

3Com Corporation

350 Campus drive, Marlboro Massachusetts 01752-3064, USA

1.2. Manufacturer

DONGGUAN G-COM COMPUTER CO., LTD.

1st Row Yin Shan Rd., Yin Hwu Industrial Area, Qingxi Town, Dong Guan City, Guang Dong, China

1.3. Basic Description of Equipment under Test

This product is a Wireless Access Point with 802.11a/b/g wireless solution. The technical data has been listed on section " Features of Equipment under Test ". There are RJ45, RS-232 and power ports in this product. 4 types of antenna were filed in this project.

1.4. Features of Equipment under Test

Items	Description
Type of Modulation	: OFDM (16QAM / 64QAM / DQPSK / DBPSK)
Number of Channels	: 19
Frequency Band	: 5150MHz ~ 5250MHz, 5250MHz ~ 5350MHz 5725MHz ~ 5805MHz
Carrier Frequency	: See section 1.6 for details
Data Rate	: 54, 48,36, 24,18,12, 6Mbps
Channel Bandwidth	: 18MHz
Max. Conducted Output Power	: See section 1.7 for details
Antenna Type	: See section 1.5 for details
Communication Type	: Half-Duplex
Testing Duty Cycle	: 100.00%
Power Rating (DC/AC, Voltage)	: 110 VAC to 5 VDC
Test Power Source	: 110.00V AC
Temperature Range (Operating)	: -30 ~ 50 °C



1.5. Antenna Description

4 types of antenna were filed in this project.

No.	Antenna Type	Gain (dBi)
1	Ceiling Antenna (3CWE592)	4.00dBi @5.0GHz
2	Hallway Antenna (3CWE597)	6.00dBi @5.0GHz
3	Omni Antenna (3CWE591)	8.00dBi @5.0GHz
4	SMA Omni Antenna (3CWE502)	2.50dBi @5.0GHz

1.6. Table for Carrier Frequencies

Normal Mode

Frequency Bands					
5150MHz ~ 5250MHz		5250MHz ~ 5350MHz		5725MHz ~ 5825MHz	
Channel	Frequency	Channel	Frequency	Channel	Frequency
01	5180 MHz	05	5260 MHz	09	5745 MHz
02	5200 MHz	06	5280 MHz	10	5765 MHz
03	5220 MHz	07	5300 MHz	11	5785 MHz
04	5240 MHz	08	5320 MHz	12	5805 MHz

Turbo Mode

Frequency Bands					
5150MHz ~ 5250MHz		5250MHz ~ 5350MHz		5725MHz ~ 5825MHz	
Channel	Frequency	Channel	Frequency	Channel	Frequency
01	5210 MHz	03	5290 MHz	04	5760 MHz
02	5250 MHz			05	5800 MHz



1.7. Table for Maximum Conducted Output Power

Normal Mode

Mode 1 ~ Mode 3

Maximum Conducted Output Power (dBm)		
Frequency Bands 5150MHz ~ 5250MHz	Frequency Bands 5250MHz ~ 5350MHz	Frequency Bands 5725MHz ~ 5825MHz
14.91	21.40	23.44

Mode 4

Maximum Conducted Output Power (dBm)		
Frequency Bands 5150MHz ~ 5250MHz	Frequency Bands 5250MHz ~ 5350MHz	Frequency Bands 5725MHz ~ 5825MHz
16.59	20.99	20.61

Turbo Mode

Mode 1 ~ Mode 3

Maximum Conducted Output Power (dBm)		
Frequency Bands 5150MHz ~ 5250MHz	Frequency Bands 5250MHz ~ 5350MHz	Frequency Bands 5725MHz ~ 5825MHz
14.31	18.19	17.30

Mode 4

Maximum Conducted Output Power (dBm)		
Frequency Bands 5150MHz ~ 5250MHz	Frequency Bands 5250MHz ~ 5350MHz	Frequency Bands 5725MHz ~ 5825MHz
16.57	20.72	20.73

2. Test Configuration of the Equipment under Test

2.1. Connection Diagram of Test System

Antenna 1, 2, & 3

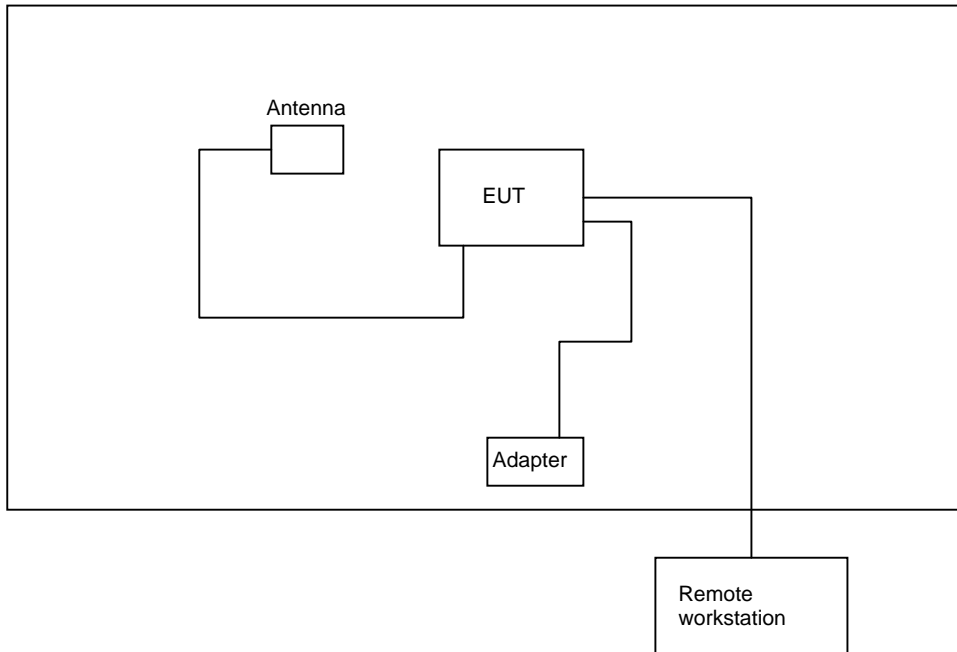

Antenna 4

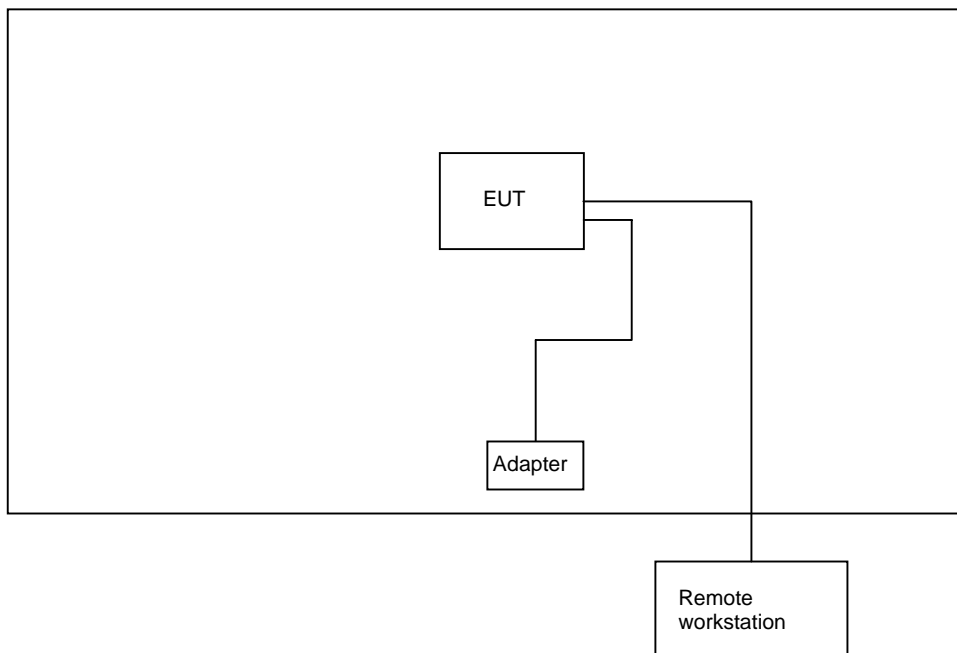



2.2. The Test Mode Description

1. For OFDM modulation, 64QAM is the worst case on all test items.
2. This device is able to be powered by adapter and POE, so an extra mode on POE for spurious emission below 1GHz was tested.
3. AC conduction emission is independent of channel selection, so only channel 01 was the tested case.
4. Operating channel with carrier located within 5.47~5.725GHz was not included in this test report.
5. There are 4 types of antennas during the testing.

Mode 1 : Ceiling Antenna (3CWE592)

Mode 2 : Halfway Antenna (3CWE597)

Mode 3 : Omni Antenna (3CWE591)

Mode 4 : SMA Omni Antenna (3CWE502)

2.3. Description of Test Supporting Units

No supporting unit is required for the EUT.



3. General Information of Test

3.1. Test Facility

Test Site Location : No. 52, Hwa Ya 1st Rd., Hwa Ya Technology Park, Kwei-Shan Hsiag, Tao Yuan Hsien, Taiwan, R.O.C.

: TEL 886-3-327-3456

: FAX 886-3-318-0055

Test Site No : 03CH03-HY / TH01-HY

3.2. Test Conditions

Normal Voltage : 110.00V (power adapter)

Extreme Voltages : 126.50V and 93.5V (power adapter)

Normal Temperature : 20°C

Extreme Temperature : -30 °C and 50 °C

3.3. Standards for Methods of Measurement

Here is the list of the standards followed in this test report.

ANSI C63.4-2003

47 CFR Part 15 Subpart C (Section 15.407)

3.4. DoC Statement

This EUT is also classified as a device of computer peripheral Class B which DoC has to be followed. It has been verified according to the rule of 47 CFR part 15 Subpart B, and found that all the requirements has been fulfilled.

3.5. Frequency Range Investigated

Radiated emission test: from 30 MHz to 10th carrier harmonic.

3.6. Test Distance

The test distance of radiated emission (30MHz~1GHz) test from antenna to EUT is 3 M.

The test distance of radiated emission (1GHz~10th carrier harmonic) test from antenna to EUT is 3 M.

3.7. Test Software

During testing, Channel & Power Controlling Software: This was provided by the manufacturer and is able to let the test engineer select the operating channel as well as the RF output power. The parameters for channel selection is trying to offer the test engineer the ability to fix the operating channel for testing, both normal data and continuously transmitting modes are allowed, and that for RF output power selection is for the setting of RF output power expected by the customer and is going to be fixed on the firmware of the final end product.



4. List of Measurements

4.1. Summary of the Test Results

Applied Standard: 47 CFR Part 15 and Part 2

Paragraph	FCC Rule	Description of Test	Result
5.1	15.407	26dB Spectrum Bandwidth	Pass
5.2	15.407	Maximum Conducted Output Power	Pass
5.3	15.407	Peak Power Spectral Density	Pass
5.4	15.407	Ratio of the Peak Excursion	Pass
5.5	15.407	Band Edges Emission	Pass
5.6	15.407	Test of Frequency Stability	Pass
5.7	15.407	AC Power Line Conducted Emission	Pass
5.8	15.209/15.407	Spurious Radiated Emission	Pass
5.9	15.203/15.407	Antenna Requirement	Pass
5.10	2.1091	Maximum Permissible Exposure	Pass

5. Test Result

5.1. Test of 26dB Spectrum Bandwidth

5.1.1. Measuring Instruments

Item 18 of the table is on section 6.

5.1.2. Test Procedures

1. The transmitter output was connected to the spectrum analyzer through an attenuator.
2. Set RBW of spectrum analyzer to 300KHz and VBW to 1000KHz.
3. The spectrum width with level higher than 26dB below the peak level.

5.1.3. Test Setup Layout

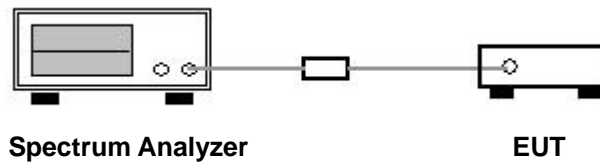

5.1.4. Test Result: See spectrum analyzer plots below

- Temperature: 26°C
- Relative Humidity: 64%
- Duty Cycle of the Equipment During the Test: 100.00%
- Test Engineer: Sam Lee

Normal Mode

Channel	Frequency (MHz)	26dB Bandwidth (MHz)	Calculated Power Limit (dBm)	Applied Power Limit (dBm)
01	5180 MHz	23.60	17.73	17
02	5200 MHz	27.80	18.44	17
04	5240 MHz	27.00	18.31	17
05	5260 MHz	36.30	26.60	24
06	5280 MHz	38.30	26.83	24
08	5320 MHz	24.40	24.87	24
09	5745 MHz	24.50	30.69	30
10	5765 MHz	29.10	32.43	30
12	5805 MHz	28.20	30.86	30



Turbo Mode

Channel	Frequency (MHz)	26dB Bandwidth (MHz)	Calculated Power Limit (dBm)	Applied Power Limit (dBm)
01	5210 MHz	47.40	20.76	17
02	5250 MHz	47.40	27.76	17
03	5290 MHz	45.40	27.57	24
04	5760 MHz	45.80	33.63	30
05	5800 MHz	48.60	33.55	30



Normal Mode

Channel: 01 / 5180 MHz

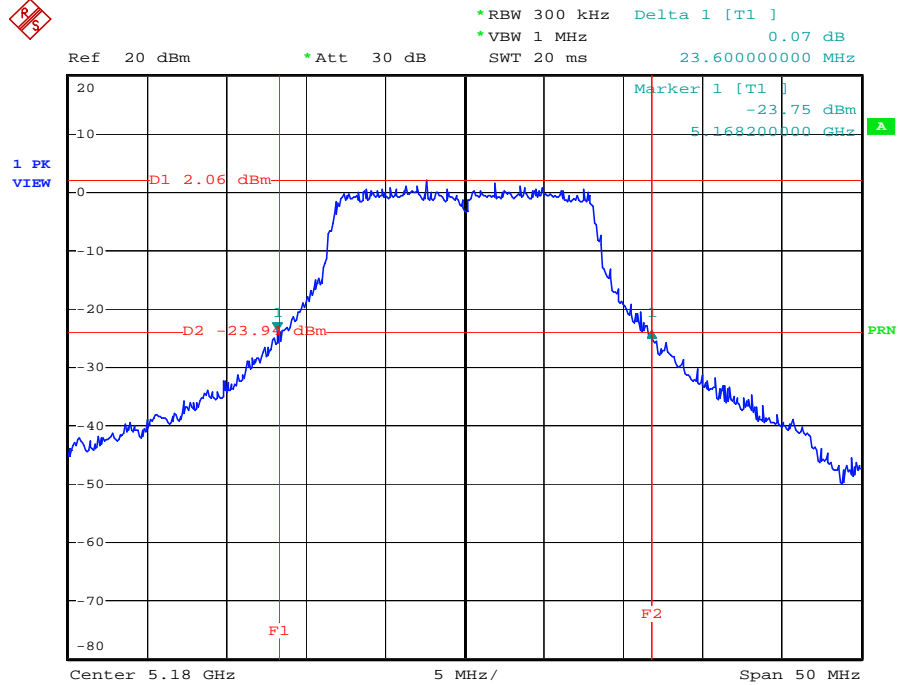

Date: 23.OCT.2004 10:57:26

Channel: 02 / 5200 MHz

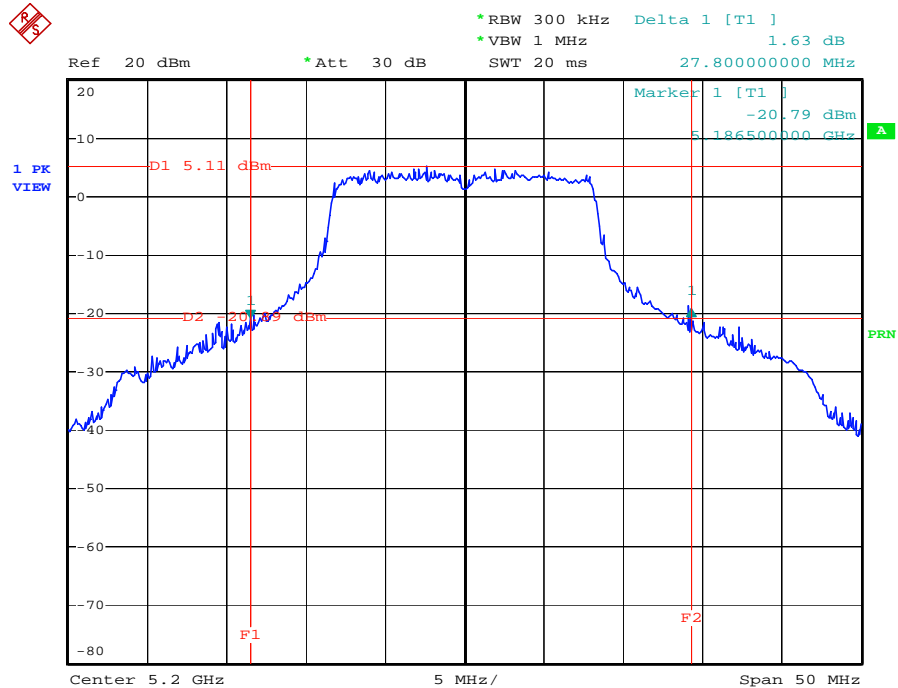

Date: 23.OCT.2004 10:59:46



Channel: 04 / 5240 MHz

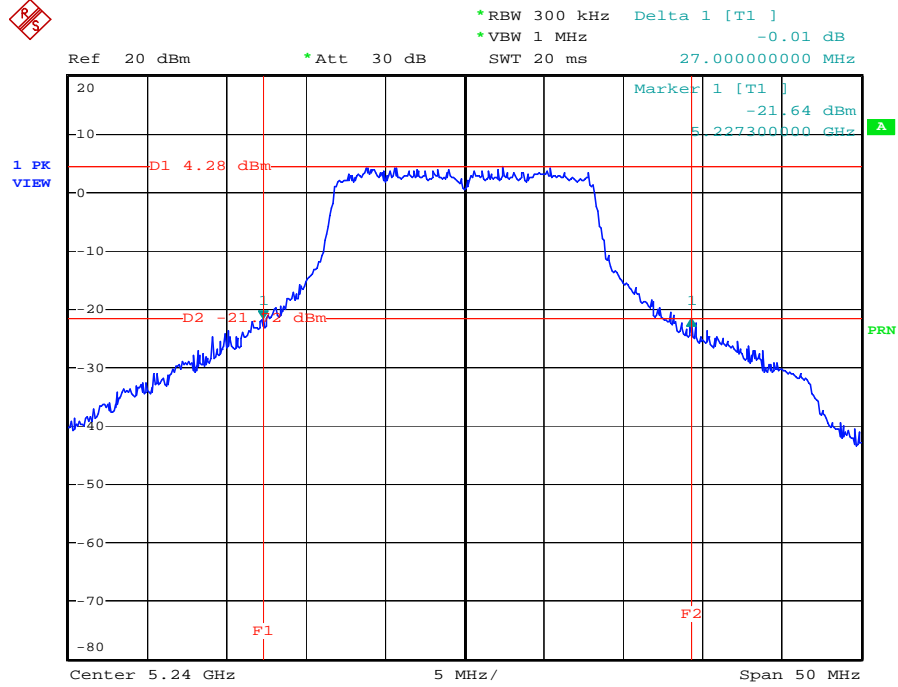

Date: 23.OCT.2004 11:03:20

Channel: 05 / 5260 MHz

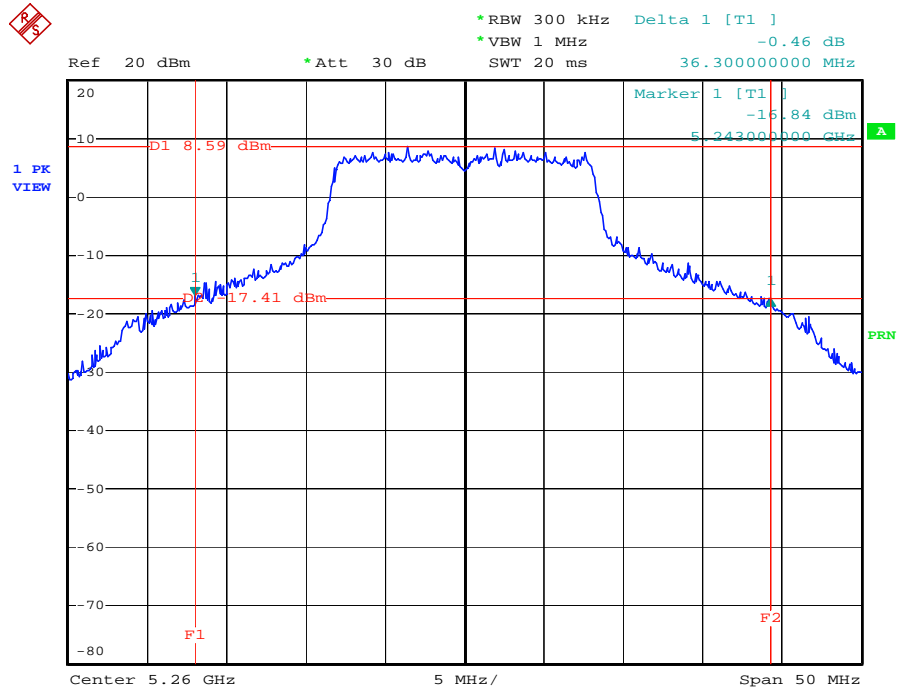

Date: 23.OCT.2004 11:06:11



Channel: 06 / 5280 MHz

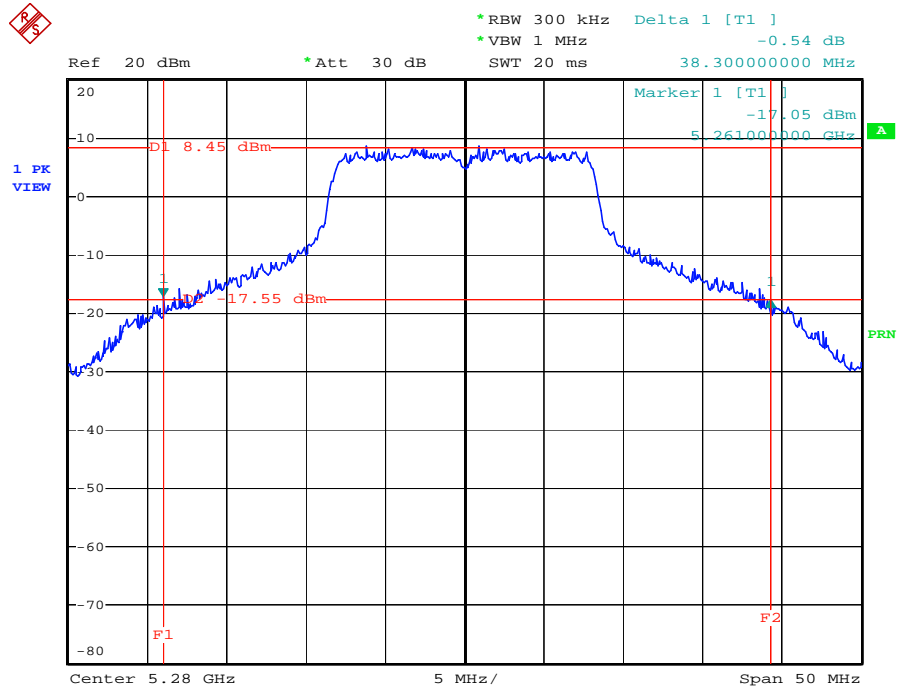

Date: 23.OCT.2004 11:07:56

Channel: 08 / 5320 MHz

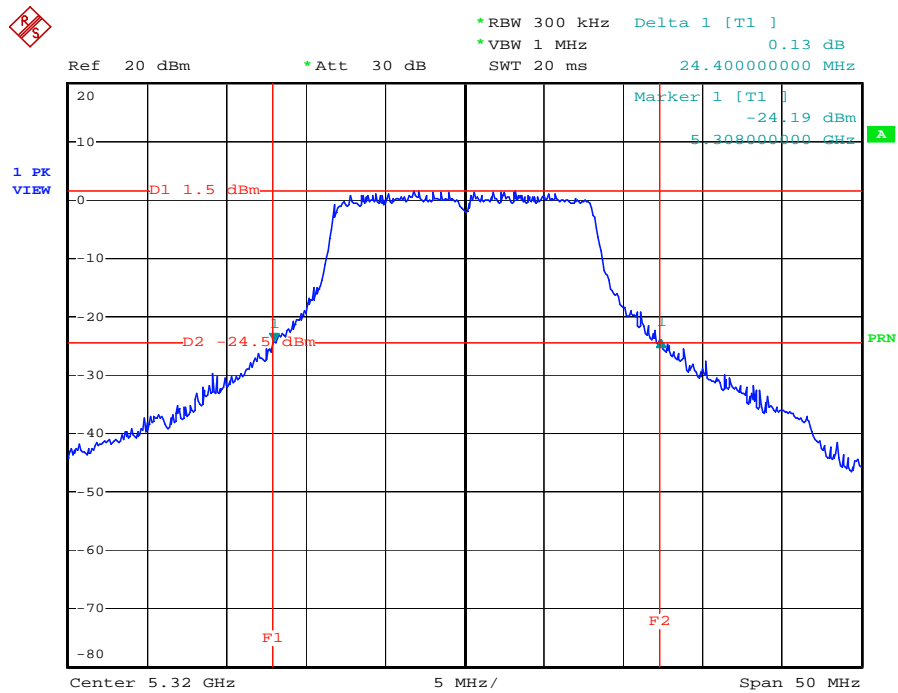

Date: 23.OCT.2004 11:29:30



Channel: 12 / 5805 MHz

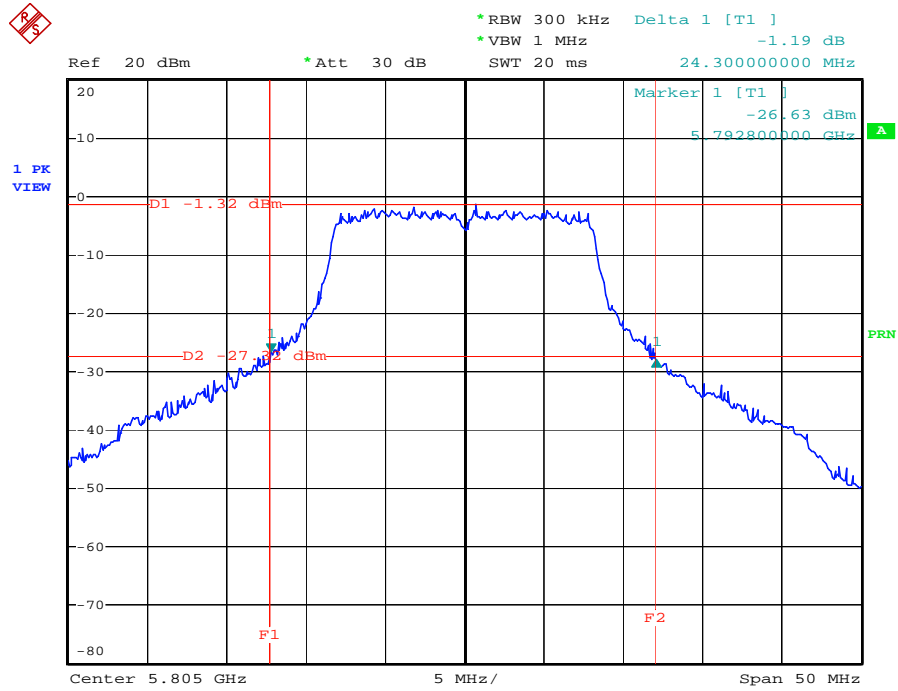

Date: 23.OCT.2004 11:48:58



Turbo Mode

Channel: 01 / 5210 MHz

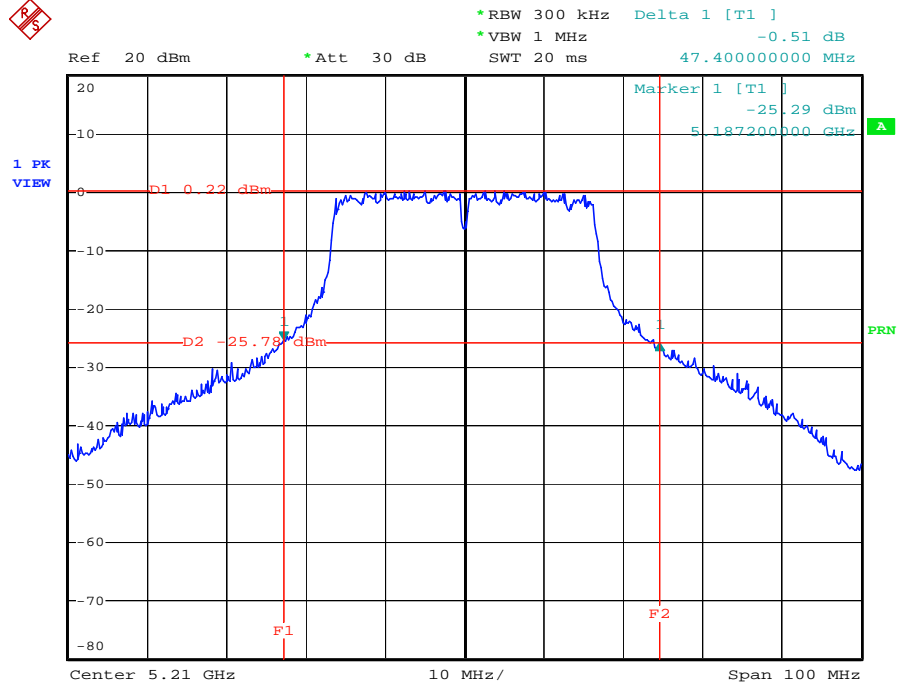

Date: 23.OCT.2004 12:08:15

Channel: 02 / 5250 MHz

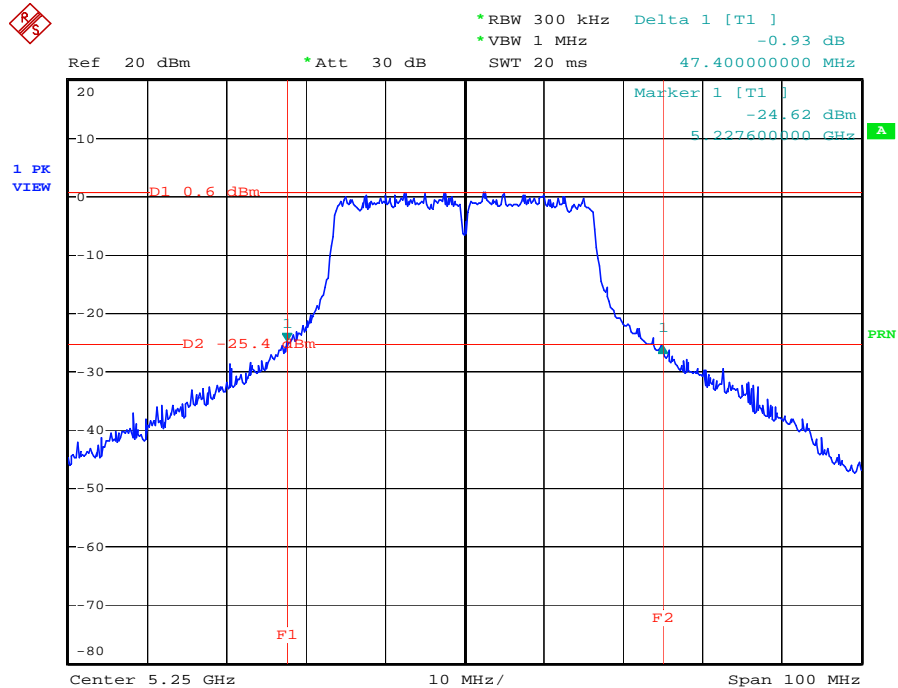

Date: 23.OCT.2004 12:10:23



Channel: 03 / 5290 MHz

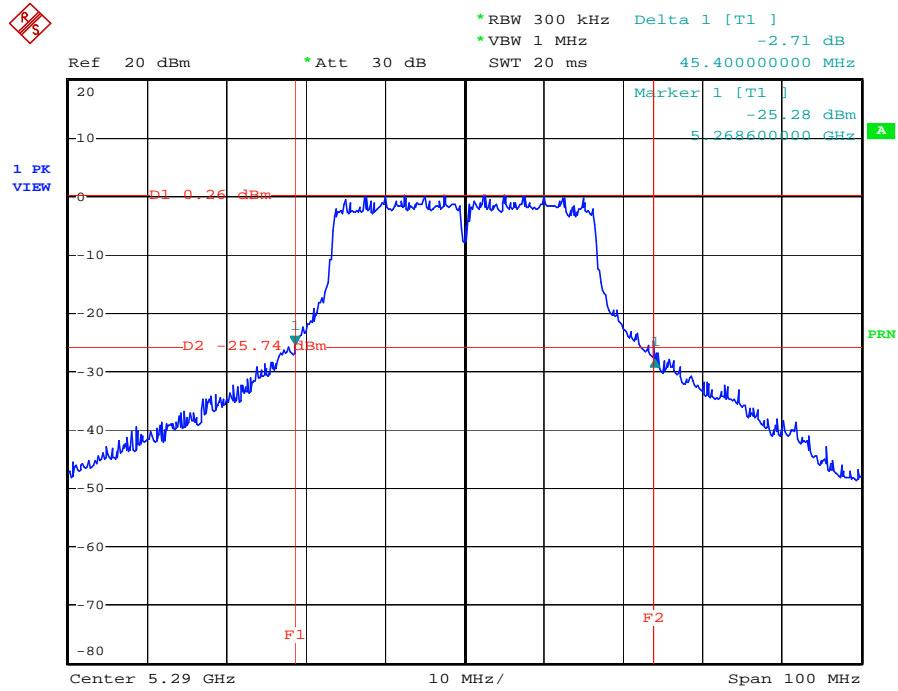

Date: 23.OCT.2004 12:11:56

Channel: 04 / 5760 MHz

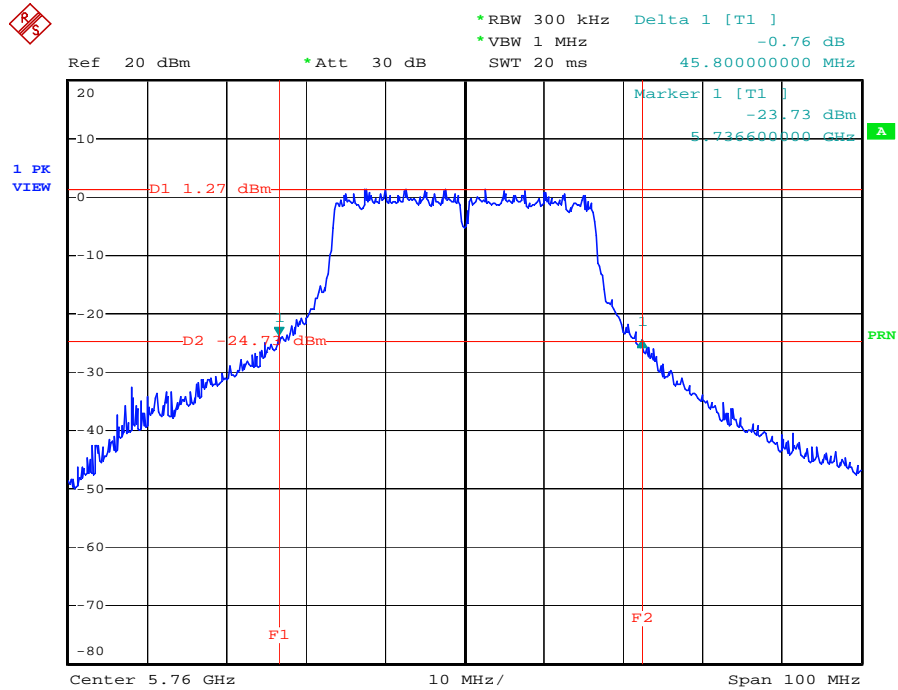

Date: 23.OCT.2004 11:56:25



Channel: 05 / 5800 MHz

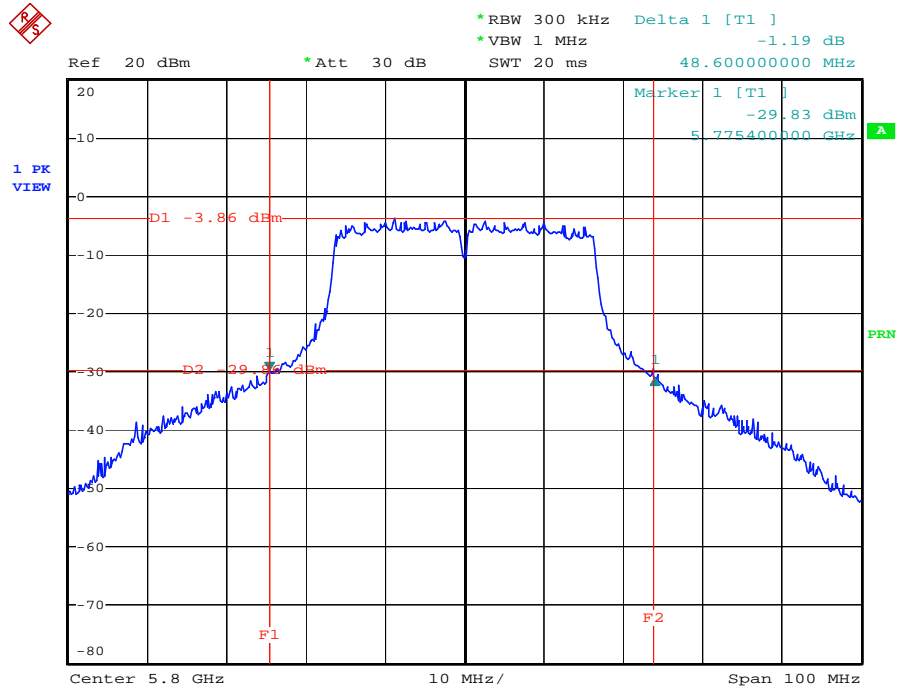

Date: 23.OCT.2004 11:53:40

5.2. Test of Maximum Conducted Output Power

5.2.1. Measuring Instruments

Item 18 of the table is on section 6.

5.2.2. Test Procedures

1. According to FCC DA 02-2138 test procedure, EUT connected to spectrum analyzer, then used the channel power function of spectrum analyzer and calculated total average power with spectrum range more than 26dB bandwidth.
2. Repeated the 1 for the middle and highest channel of the EUT.

5.2.3. Test Setup Layout

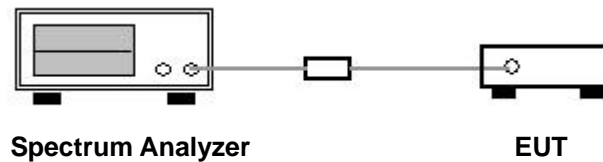



5.2.4. Test Result of Conducted Power

- Temperature: 26°C
- Relative Humidity: 64%
- Duty Cycle of the Equipment During the Test: 100.00%
- Test Engineer: Sam Lee

Mode 1 ~ Mode 3

Normal Mode

Channel	Frequency (MHz)	Output Power (dBm)	Lowest Limits (dBm)
01	5180 MHz	14.77	15
02	5200 MHz	14.91	15
04	5240 MHz	14.28	15
05	5260 MHz	21.26	22
06	5280 MHz	21.40	22
08	5320 MHz	15.21	22
09	5745 MHz	13.08	28
10	5765 MHz	23.44	28
12	5805 MHz	13.96	28

The max output power in normal mode:
5150MHz~5250MHz is 14.91dBm / 5250MHz~5350MHz is 21.40dBm
5725MHz~5825MHz is 23.44dBm

Turbo Mode

Channel	Frequency (MHz)	Output Power (dBm)	Lowest Limits (dBm)
01	5210 MHz	14.31	15
02	5250 MHz	14.30	15
03	5290 MHz	18.19	22
04	5760 MHz	17.30	28
05	5800 MHz	11.37	28

The max output power in turbo mode:
5150MHz~5250MHz is 14.31dBm / 5250MHz~5350MHz is 18.19dBm
5725MHz~5825MHz is 17.30dBm



Normal Mode (Mode 1 ~ Mode 3)

Channel: 01 / 5180 MHz

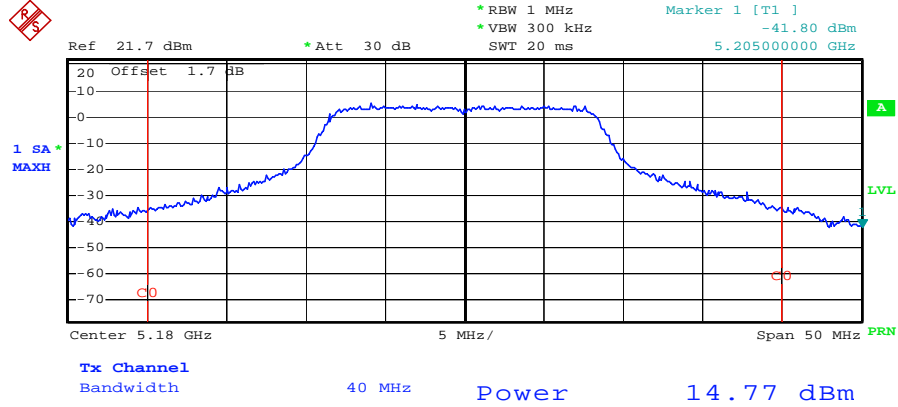

Date: 23.OCT.2004 13:02:52

Channel: 02 / 5200 MHz

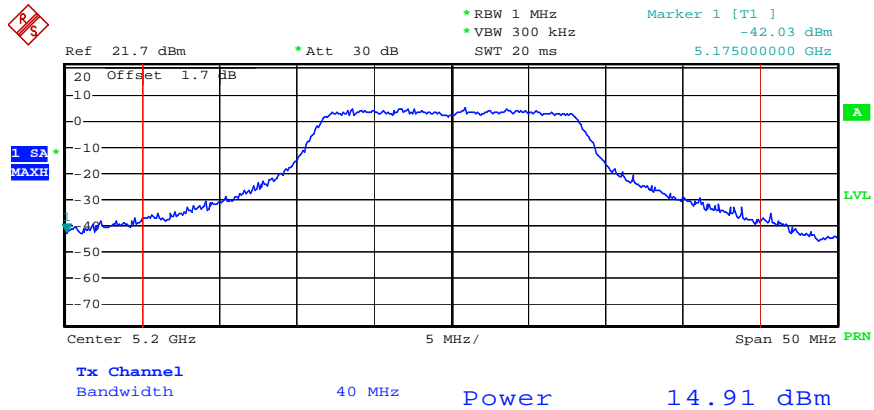

Date: 4.NOV.2004 16:02:02



Channel: 04 / 5240 MHz

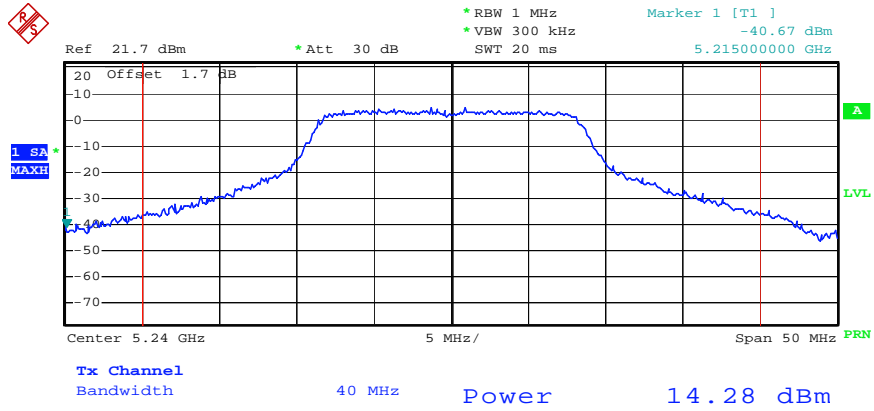

Date: 4.NOV.2004 16:06:42

Channel: 05 / 5260 MHz

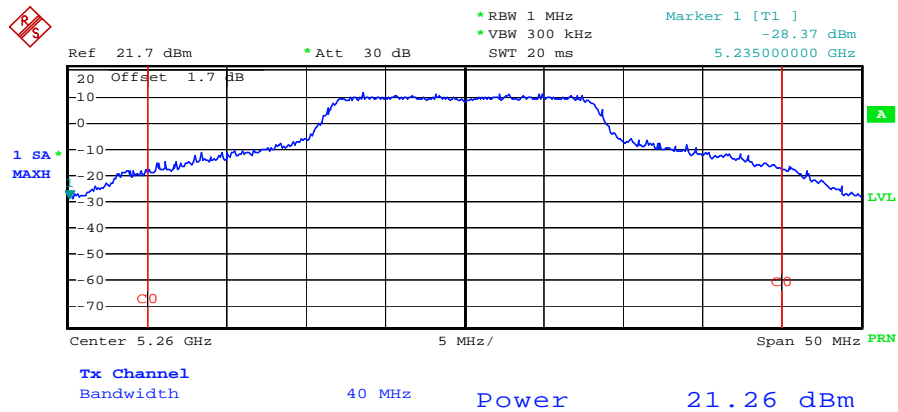

Date: 23.OCT.2004 13:16:44



Channel: 06 / 5280 MHz

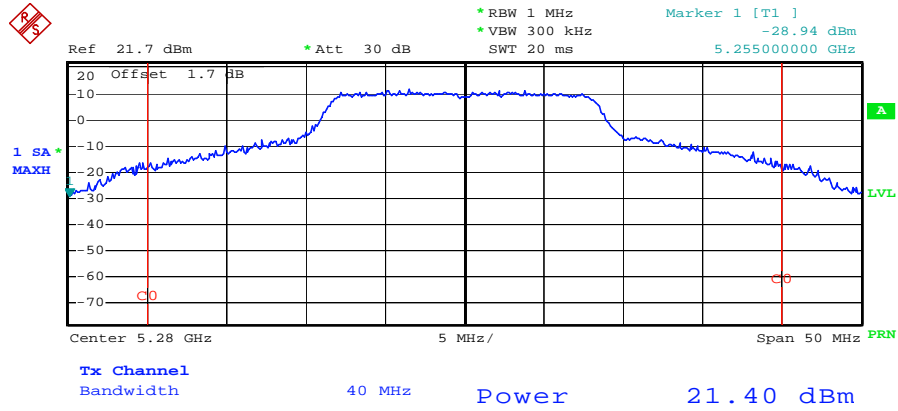

Date: 23.OCT.2004 13:17:38

Channel: 08 / 5320 MHz

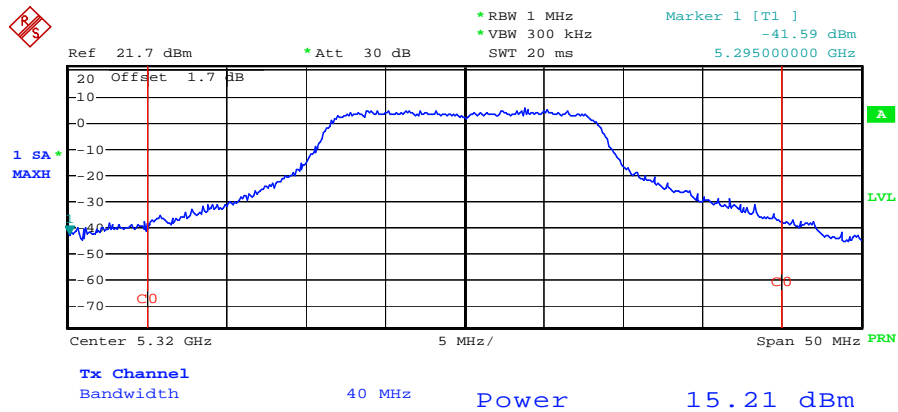

Date: 23.OCT.2004 13:19:56



Channel: 09 / 5745 MHz

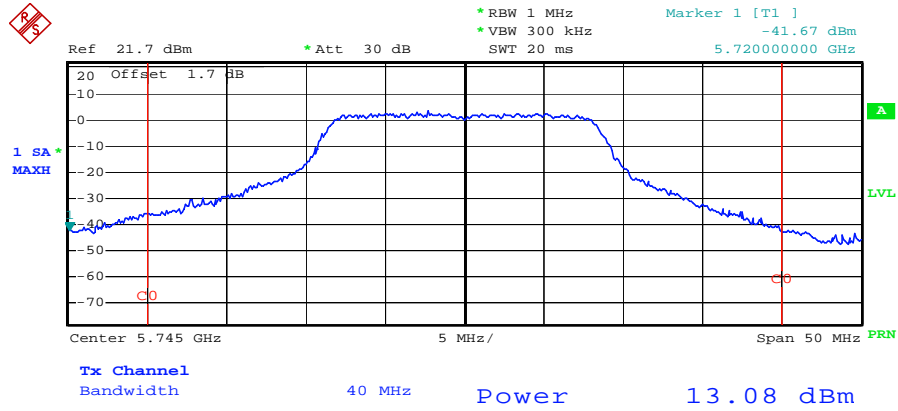

Date: 23.OCT.2004 13:36:44

Channel: 10 / 5765 MHz

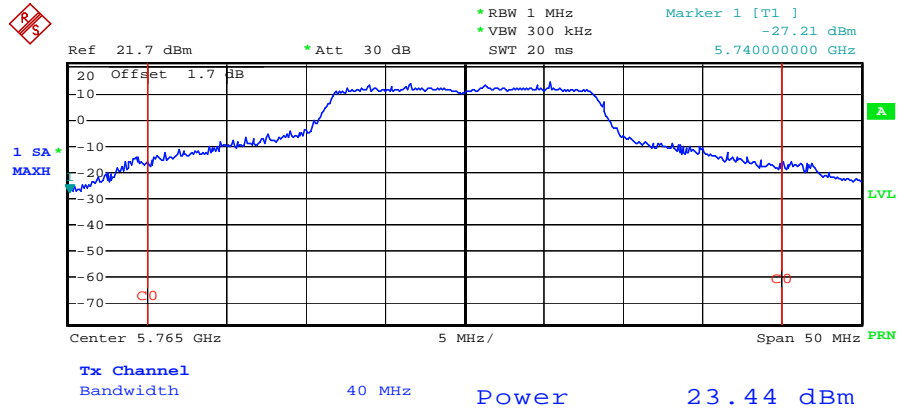

Date: 23.OCT.2004 13:37:52



Channel: 12 / 5805 MHz

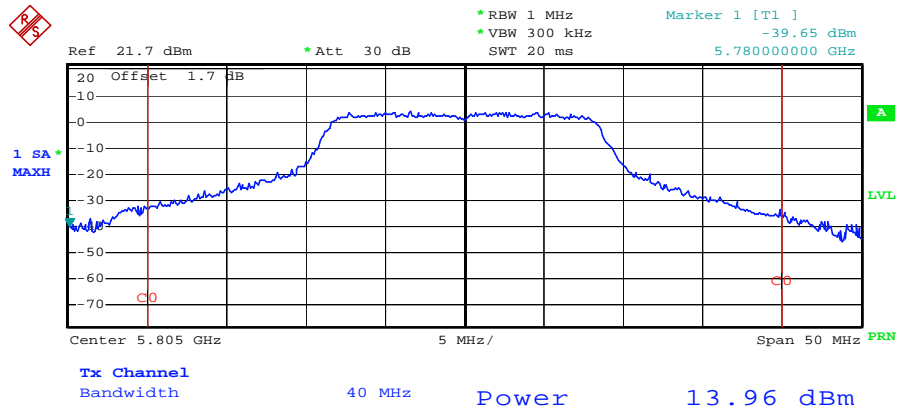

Date: 23.OCT.2004 13:41:10

Turbo Mode (Mode 1 ~ Mode 3)

Channel: 01 / 5210 MHz

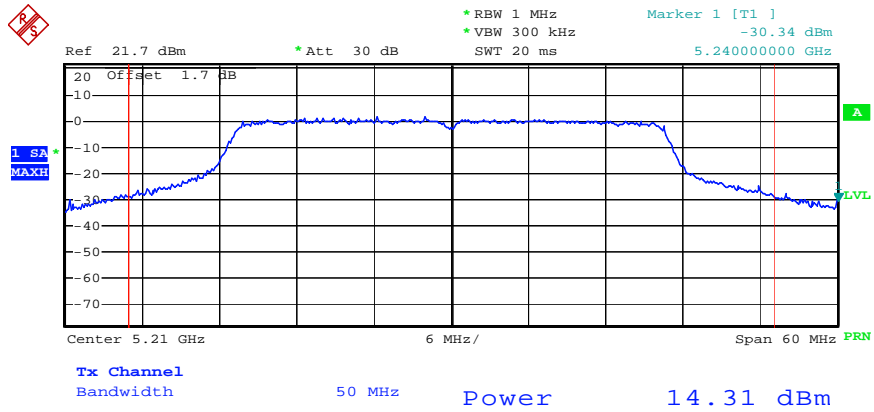

Date: 4.NOV.2004 18:11:55



Channel: 02 / 5250 MHz

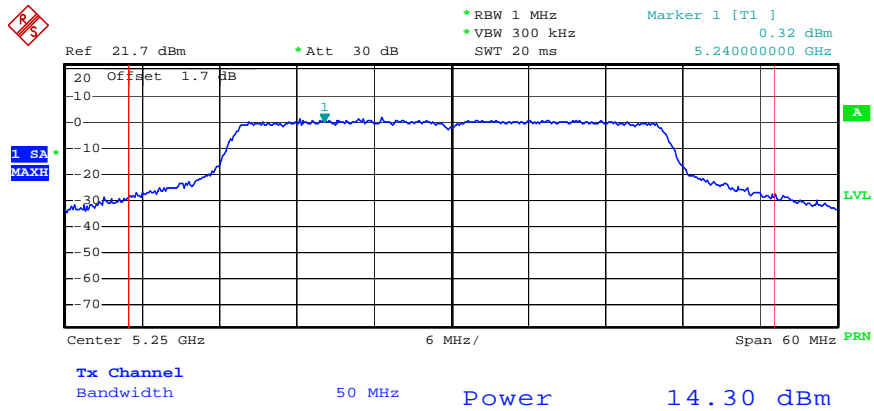

Date: 4.NOV.2004 18:15:09

Channel: 03 / 5290 MHz

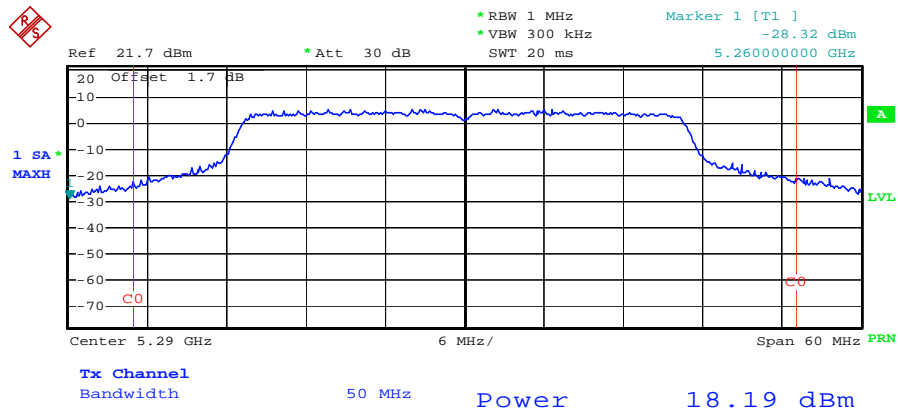

Date: 23.OCT.2004 14:07:41



Channel: 04 / 5760 MHz

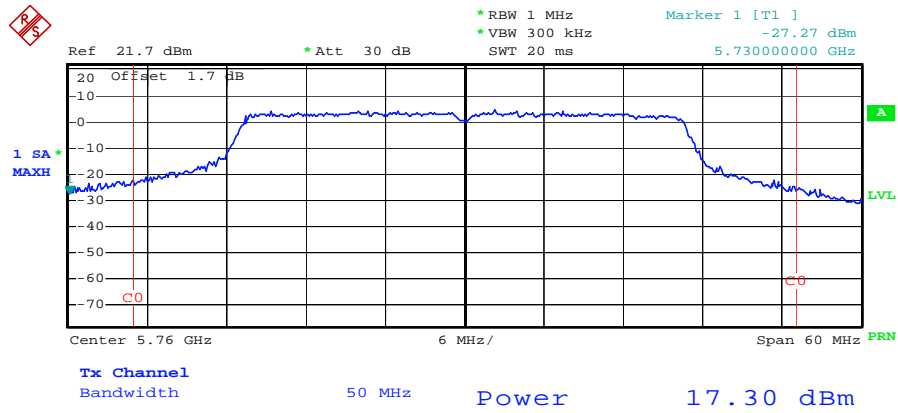

Date: 23.OCT.2004 14:14:44

Channel: 05 / 5800 MHz

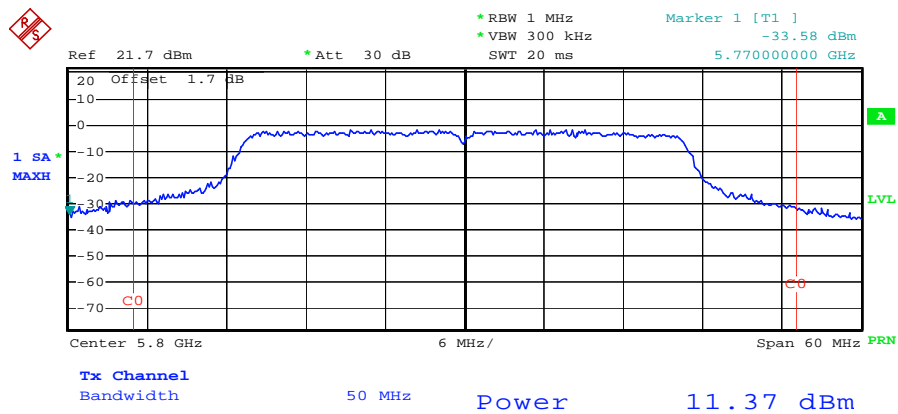

Date: 23.OCT.2004 14:15:37



- Temperature: 26°C
- Relative Humidity: 64%
- Duty Cycle of the Equipment During the Test: 100.00%
- Test Engineer: Sam Lee

Mode 4

Normal Mode

Channel	Frequency (MHz)	Output Power (dBm)	Limits (dBm)
01	5180 MHz	16.57	17
02	5200 MHz	16.52	17
04	5240 MHz	16.59	17
05	5260 MHz	19.97	24
06	5280 MHz	20.18	24
08	5320 MHz	20.99	24
09	5745 MHz	20.61	30
10	5765 MHz	20.59	30
12	5805 MHz	20.16	30

The max output power in normal mode:
5150MHz~5250MHz is 16.59dBm / 5250MHz~5350MHz is 20.99dBm
5725MHz~5825MHz is 20.61dBm

Turbo Mode

Channel	Frequency (MHz)	Output Power (dBm)	Limits (dBm)
01	5210 MHz	16.57	17
02	5250 MHz	16.50	17
03	5290 MHz	20.72	24
04	5760 MHz	20.73	30
05	5800 MHz	16.30	30

The max output power in turbo mode:
5150MHz~5250MHz is 16.57dBm / 5250MHz~5350MHz is 20.72dBm
5725MHz~5825MHz is 20.73dBm



Normal Mode (Mode 4)

Channel: 01 / 5180 MHz

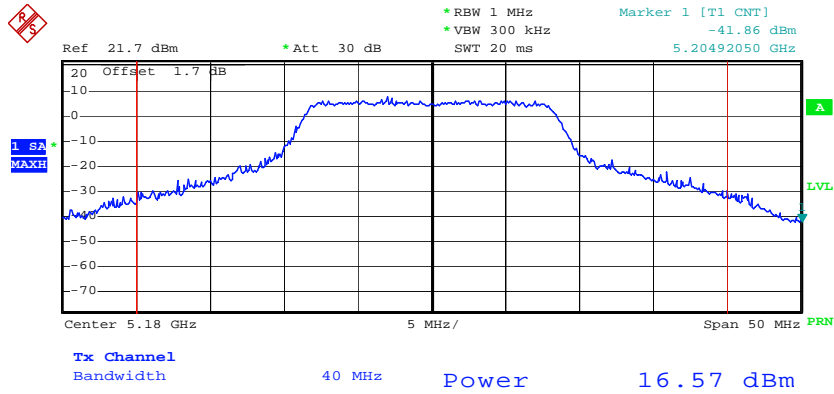

Date: 22.NOV.2004 12:26:25

Channel: 02 / 5200 MHz

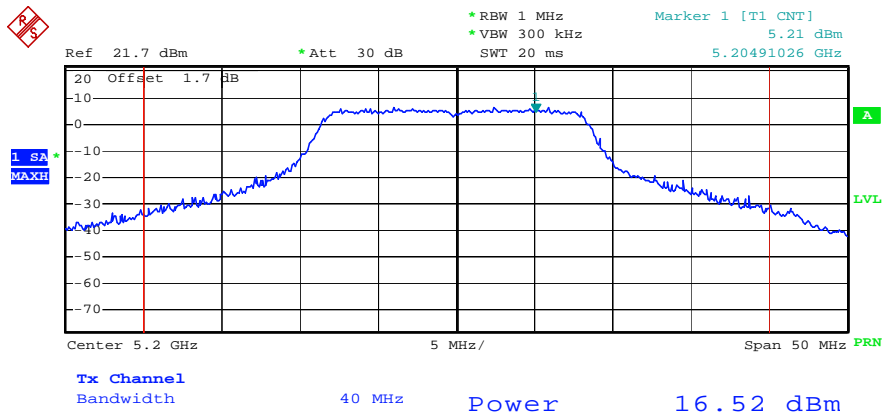

Date: 22.NOV.2004 12:29:36



Channel: 04 / 5240 MHz

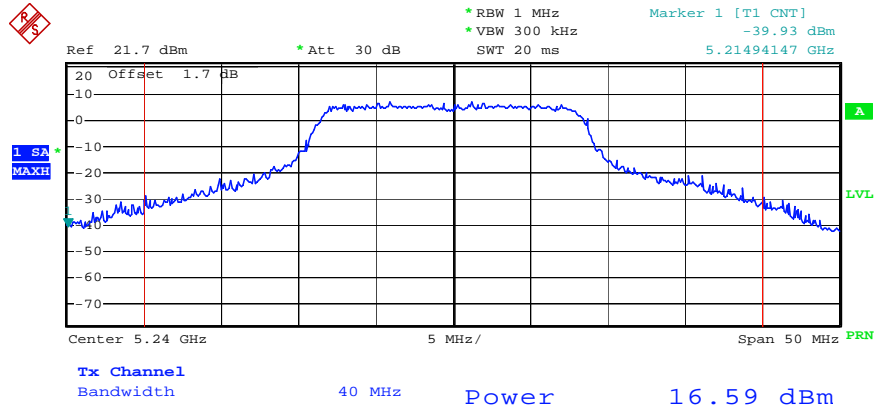

Date: 22.NOV.2004 14:34:07

Channel: 05 / 5260 MHz

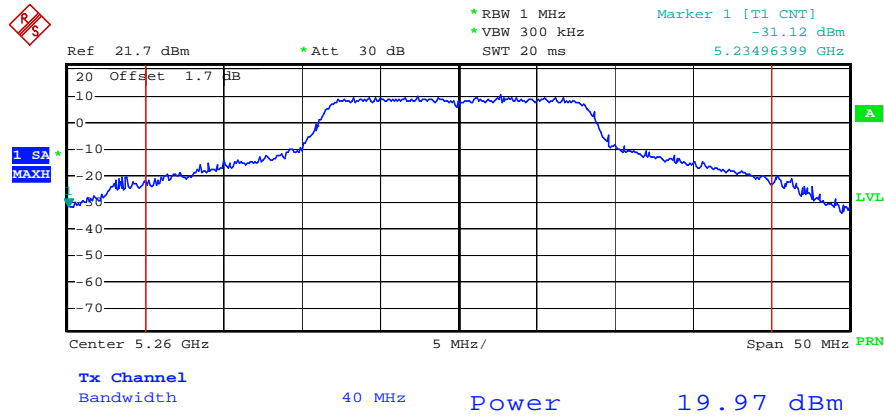

Date: 22.NOV.2004 14:38:28



Channel: 06 / 5280 MHz

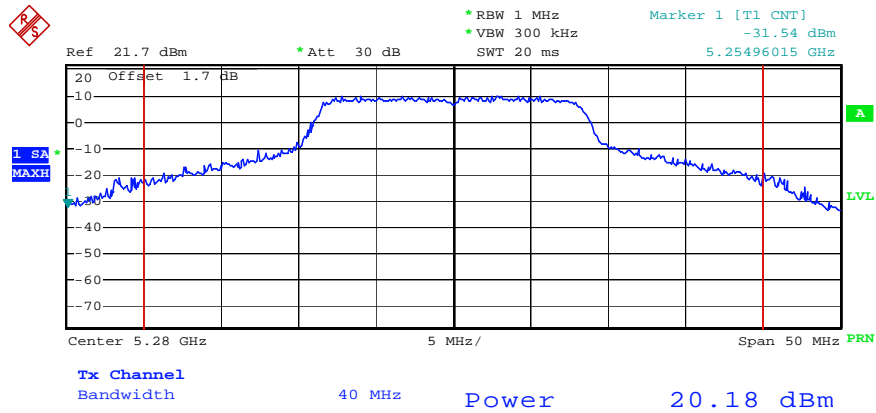

Date: 22.NOV.2004 14:39:41

Channel: 08 / 5320 MHz

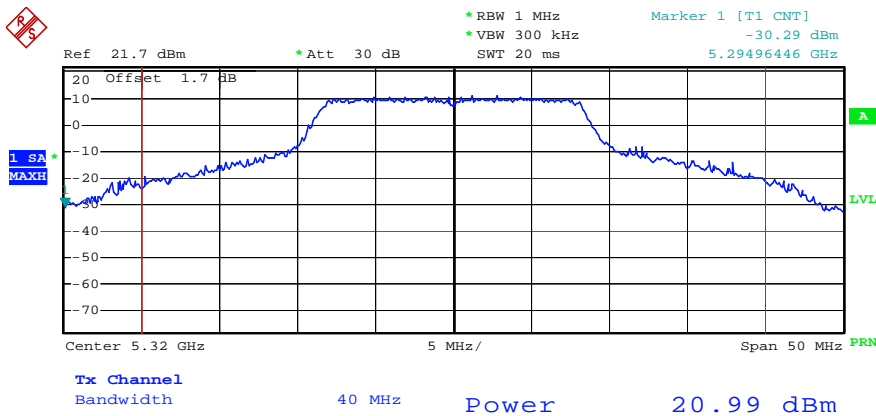

Date: 22.NOV.2004 14:41:53



Channel: 09 / 5745 MHz

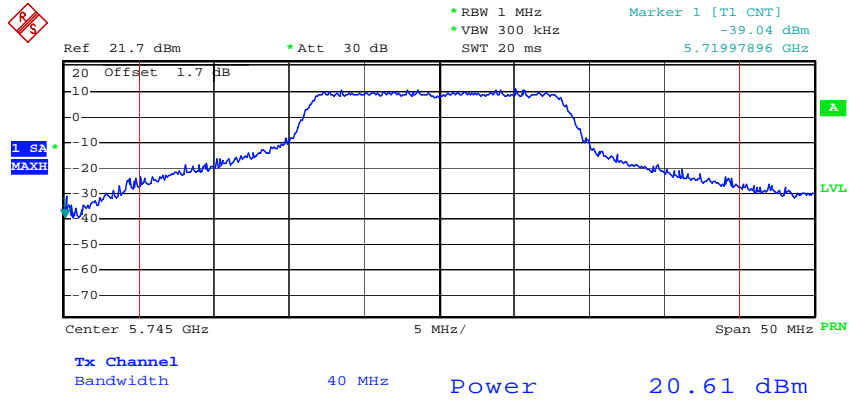

Date: 22.NOV.2004 14:46:27

Channel: 10 / 5765 MHz

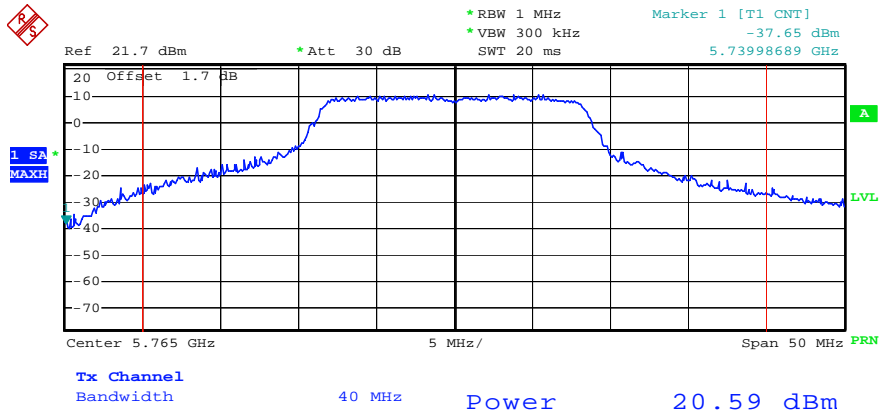

Date: 22.NOV.2004 14:47:57



Channel: 12 / 5805 MHz

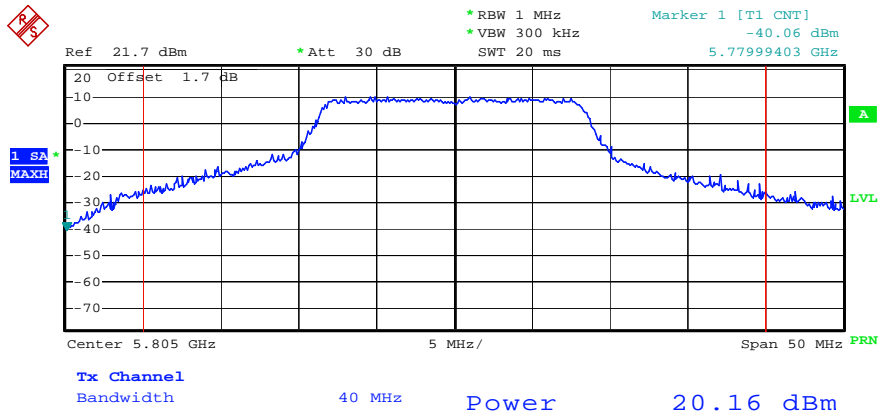

Date: 22.NOV.2004 14:49:18

Turbo Mode (Mode 4)

Channel: 01 / 5210 MHz

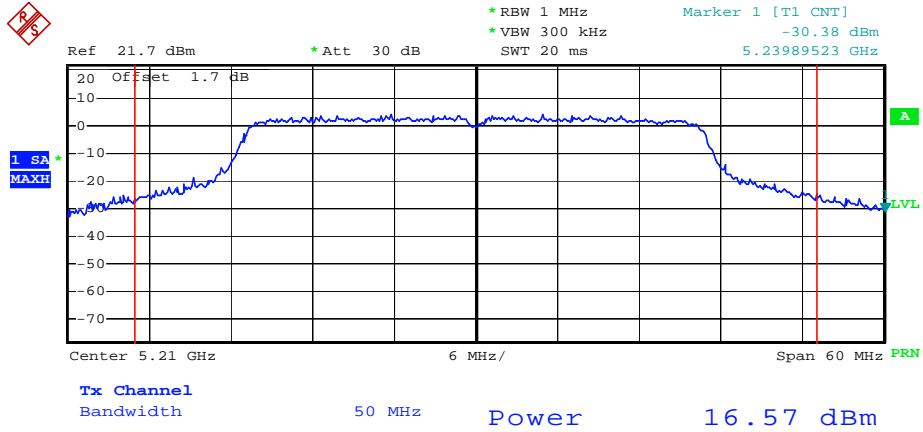

Date: 22.NOV.2004 14:52:08



Channel: 02 / 5250 MHz

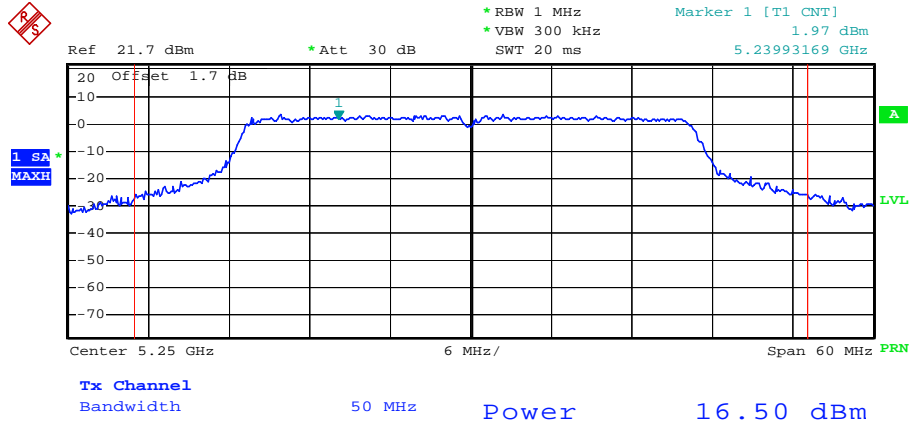

Date: 22.NOV.2004 14:54:01

Channel: 03 / 5290 MHz

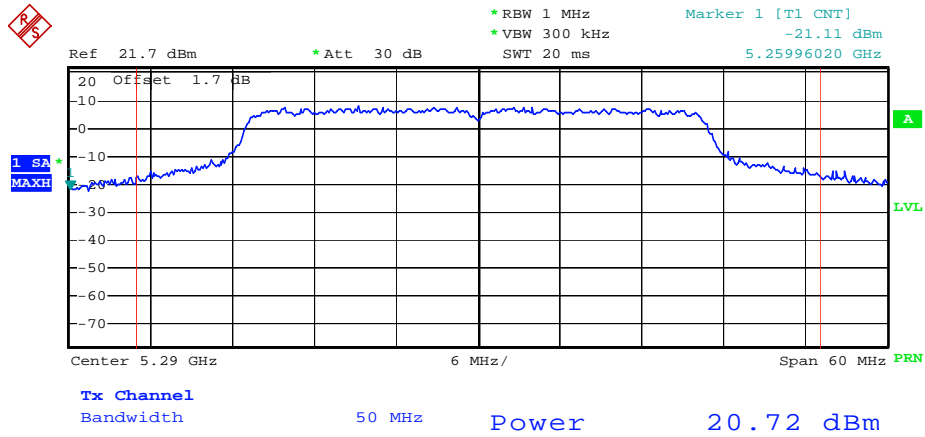

Date: 22.NOV.2004 14:55:54



Channel: 04 / 5760 MHz

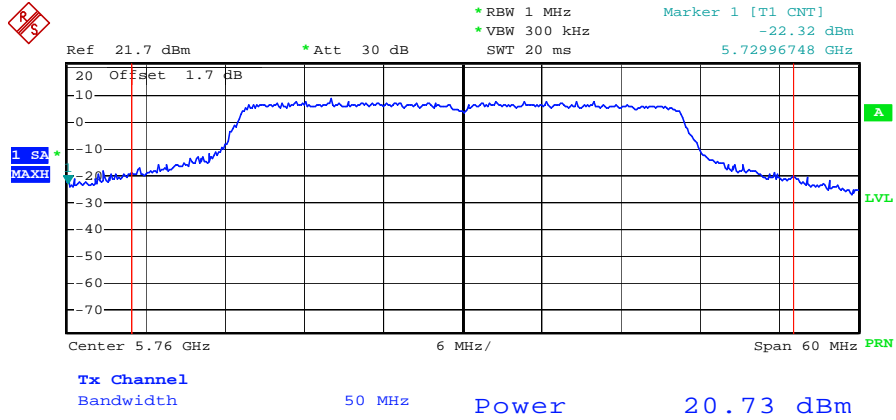

Date: 22.NOV.2004 14:57:16

Channel: 05 / 5800 MHz

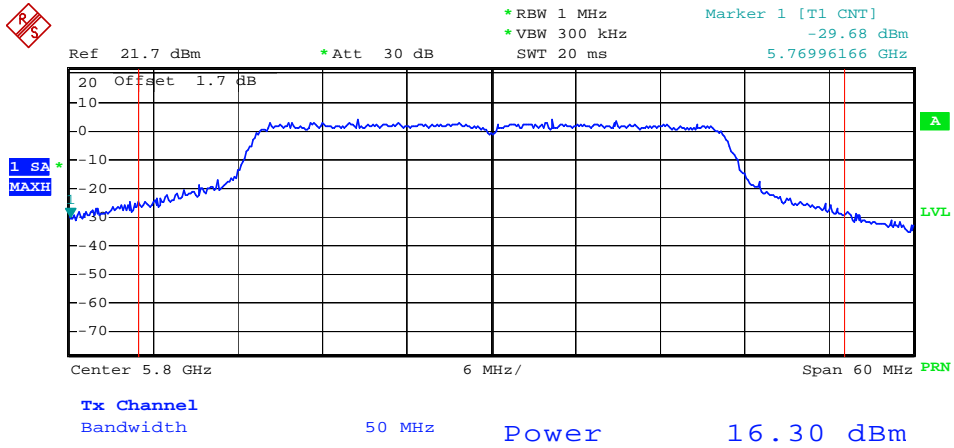

Date: 22.NOV.2004 14:58:43



5.2.5. Test Result of EIRP Power

- Temperature: 26°C
- Relative Humidity: 64%
- Duty Cycle of the Equipment During the Test: 100.00%
- Test Engineer: Sam Lee

Normal Mode

Antenna No.	Gain (dBi)	Channel	Frequency (MHz)	Output Power (dBm)	Limits (dBm)
1	4.00	01	5180 MHz	20.57	23
1	4.00	02	5200 MHz	18.91	23
1	4.00	04	5240 MHz	18.28	23
1	4.00	05	5260 MHz	25.26	30
1	4.00	06	5280 MHz	25.40	30
1	4.00	08	5320 MHz	19.21	30
1	4.00	09	5745 MHz	17.08	36
1	4.00	10	5765 MHz	27.44	36
1	4.00	12	5805 MHz	17.96	36
2	6.00	01	5180 MHz	20.77	23
2	6.00	02	5200 MHz	20.91	23
2	6.00	04	5240 MHz	20.28	23
2	6.00	05	5260 MHz	27.26	30
2	6.00	06	5280 MHz	27.40	30
2	6.00	08	5320 MHz	21.21	30
2	6.00	09	5745 MHz	24.26	36
2	6.00	10	5765 MHz	28.81	36
2	6.00	12	5805 MHz	27.66	36
3	8.00	01	5180 MHz	22.77	23
3	8.00	02	5200 MHz	22.91	23
3	8.00	04	5240 MHz	22.28	23



Antenna No.	Gain (dBi)	Channel	Frequency (MHz)	Output Power (dBm)	Limits (dBm)
3	8.00	05	5260 MHz	29.26	30
3	8.00	06	5280 MHz	29.40	30
3	8.00	08	5320 MHz	23.21	30
3	8.00	09	5745 MHz	26.26	36
3	8.00	10	5765 MHz	30.81	36
3	8.00	12	5805 MHz	29.66	36
4	2.50	01	5180 MHz	17.27	23
4	2.50	02	5200 MHz	17.41	23
4	2.50	04	5240 MHz	16.78	23
4	2.50	05	5260 MHz	23.76	30
4	2.50	06	5280 MHz	23.90	30
4	2.50	08	5320 MHz	17.71	30
4	2.50	09	5745 MHz	20.76	36
4	2.50	10	5765 MHz	25.31	36
4	2.50	12	5805 MHz	24.16	36



Turbo Mode

Antenna No.	Gain (dBi)	Channel	Frequency (MHz)	Output Power (dBm)	Limits (dBm)
1	4.00	01	5210 MHz	18.31	23
1	4.00	02	5250 MHz	18.30	23
1	4.00	03	5290 MHz	22.19	30
1	4.00	04	5760 MHz	18.23	36
1	4.00	05	5800 MHz	19.61	36
2	6.00	01	5210 MHz	20.31	23
2	6.00	02	5250 MHz	20.30	23
2	6.00	03	5290 MHz	24.19	30
2	6.00	04	5760 MHz	20.23	36
2	6.00	05	5800 MHz	21.61	36
3	8.00	01	5210 MHz	22.31	23
3	8.00	02	5250 MHz	22.30	23
3	8.00	03	5290 MHz	26.19	30
3	8.00	04	5760 MHz	22.23	36
3	8.00	05	5800 MHz	23.61	36
4	2.50	01	5210 MHz	16.81	23
4	2.50	02	5250 MHz	16.80	23
4	2.50	03	5290 MHz	20.69	30
4	2.50	04	5760 MHz	16.73	36
4	2.50	05	5800 MHz	18.11	36

5.3. Test of Peak Power Spectral Density

5.3.1. Measuring Instruments

Item 18 of the table is on section 6.

5.3.2. Test Procedures

1. Follow the procedures in FCC DA 02-2138.
2. Repeated the 1 for the middle and highest channel of the EUT.

5.3.3. Test Setup Layout

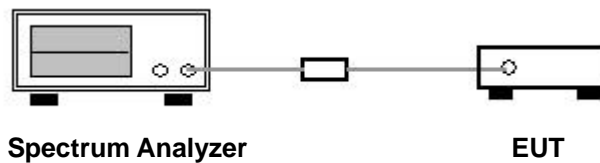

5.3.4. Test Result of conducted peak power spectral density:

- Temperature: 26°C
- Relative Humidity: 64%
- Duty Cycle of the Equipment During the Test: 100.00%
- Test Engineer: Sam Lee

Normal Mode

Mode 1 ~ Mode 3

Channel	Frequency (MHz)	Power Density (dBm)	Lowest Limits (dBm)
01	5180 MHz	-4.23	2
02	5200 MHz	-1.44	2
04	5240 MHz	-1.38	2
05	5260 MHz	2.09	9
06	5280 MHz	2.33	9
08	5320 MHz	-4.26	9
09	5745 MHz	-6.55	15
10	5765 MHz	4.54	15
12	5805 MHz	-8.07	15



Mode 4

Channel	Frequency (MHz)	Power Density (dBm)	Limits (dBm)
01	5180 MHz	-1.50	4
02	5200 MHz	-1.89	4
04	5240 MHz	-0.99	4
05	5260 MHz	1.79	11
06	5280 MHz	1.71	11
08	5320 MHz	2.59	11
09	5745 MHz	2.18	17
10	5765 MHz	1.76	17
12	5805 MHz	1.86	17



Turbo Mode

Mode 1 ~ Mode 3

Channel	Frequency (MHz)	Power Density (dBm)	Lowest Limits (dBm)
01	5210 MHz	-5.71	2
02	5250 MHz	-5.23	2
03	5290 MHz	-5.09	9
04	5760 MHz	-4.44	15
05	5800 MHz	-9.97	15

Mode 4

Channel	Frequency (MHz)	Power Density (dBm)	Limits (dBm)
01	5210 MHz	-4.67	4
02	5250 MHz	-4.97	4
03	5290 MHz	-0.44	11
04	5760 MHz	-0.56	17
05	5800 MHz	-4.82	17



5.3.5. Test Result of EIRP peak power spectral density

- Temperature: 26°C
- Relative Humidity: 64%
- Duty Cycle of the Equipment During the Test: 100.00%
- Test Engineer: Sam Lee

Normal Mode

Antenna No.	Gain (dBi)	Channel	Frequency (MHz)	Power Density (dBm)	Limits (dBm)
1	4.00	01	5180 MHz	-0.23	10
1	4.00	02	5200 MHz	2.56	10
1	4.00	04	5240 MHz	2.62	10
1	4.00	05	5260 MHz	6.09	17
1	4.00	06	5280 MHz	6.33	17
1	4.00	08	5320 MHz	-0.26	17
1	4.00	09	5745 MHz	-2.55	23
1	4.00	10	5765 MHz	8.54	23
1	4.00	12	5805 MHz	-4.07	23
2	6.00	01	5180 MHz	1.77	10
2	6.00	02	5200 MHz	4.56	10
2	6.00	04	5240 MHz	4.62	10
2	6.00	05	5260 MHz	8.09	17
2	6.00	06	5280 MHz	8.33	17
2	6.00	08	5320 MHz	1.74	17
2	6.00	09	5745 MHz	-0.55	23
2	6.00	10	5765 MHz	10.54	23
2	6.00	12	5805 MHz	-2.07	23
3	8.00	01	5180 MHz	3.77	10
3	8.00	02	5200 MHz	6.56	10
3	8.00	04	5240 MHz	6.62	10



Antenna No.	Gain (dBi)	Channel	Frequency (MHz)	Power Density (dBm)	Limits (dBm)
3	8.00	05	5260 MHz	10.09	17
3	8.00	06	5280 MHz	10.33	17
3	8.00	08	5320 MHz	3.74	17
3	8.00	09	5745 MHz	1.45	23
3	8.00	10	5765 MHz	12.54	23
3	8.00	12	5805 MHz	-0.07	23
4	2.50	01	5180 MHz	-1.73	10
4	2.50	02	5200 MHz	1.06	10
4	2.50	04	5240 MHz	1.12	10
4	2.50	05	5260 MHz	4.59	17
4	2.50	06	5280 MHz	4.83	17
4	2.50	08	5320 MHz	-1.76	17
4	2.50	09	5745 MHz	-4.05	23
4	2.50	10	5765 MHz	7.04	23
4	2.50	12	5805 MHz	-5.57	23



Turbo Mode

Antenna No.	Gain (dBi)	Channel	Frequency (MHz)	Power Density (dBm)	Limits (dBm)
1	4.00	01	5210 MHz	-1.71	10
1	4.00	02	5250 MHz	-1.23	10
1	4.00	03	5290 MHz	-1.09	17
1	4.00	04	5760 MHz	-0.44	23
1	4.00	05	5800 MHz	-5.97	23
2	6.00	01	5210 MHz	0.29	10
2	6.00	02	5250 MHz	0.77	10
2	6.00	03	5290 MHz	0.91	17
2	6.00	04	5760 MHz	1.56	23
2	6.00	05	5800 MHz	-3.97	23
3	8.00	01	5210 MHz	2.29	10
3	8.00	02	5250 MHz	2.77	10
3	8.00	03	5290 MHz	2.91	17
3	8.00	04	5760 MHz	3.56	23
3	8.00	05	5800 MHz	-1.97	23
4	2.50	01	5210 MHz	-3.21	10
4	2.50	02	5250 MHz	-2.73	10
4	2.50	03	5290 MHz	-2.59	17
4	2.50	04	5760 MHz	-1.94	23
4	2.50	05	5800 MHz	-7.47	23



Normal Mode (Mode 1~ Mode 3)

Channel: 01 / 5180 MHz

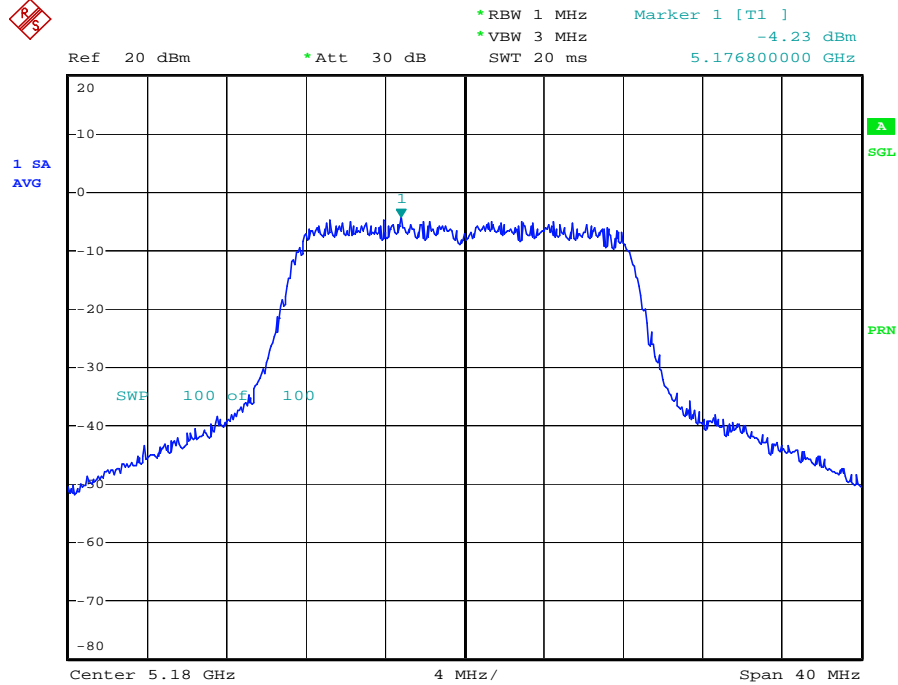

Date: 23.OCT.2004 12:38:09

Channel: 02 / 5200 MHz

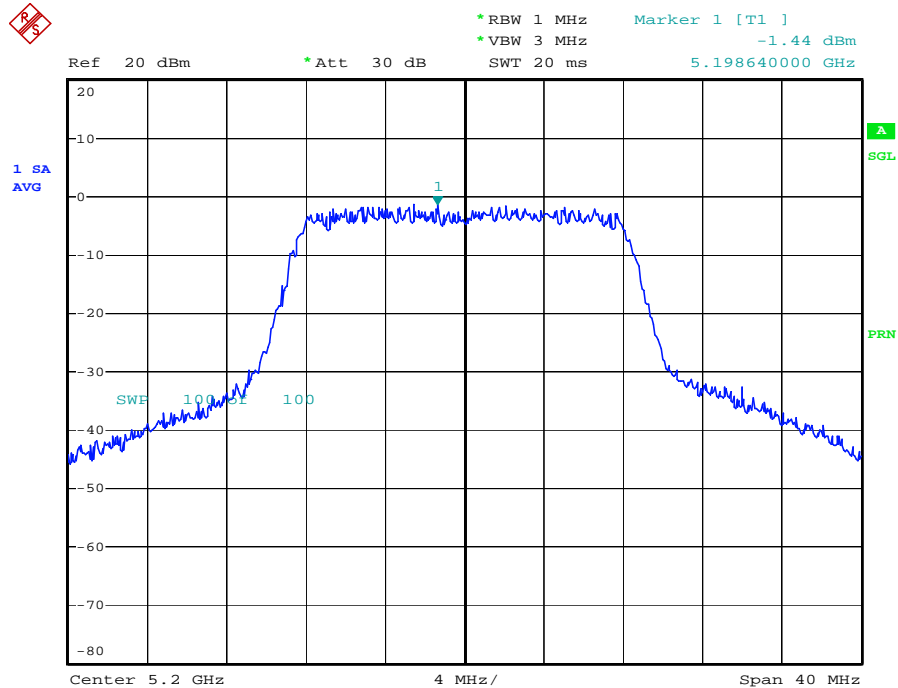

Date: 23.OCT.2004 12:39:02



Channel: 04 / 5240 MHz

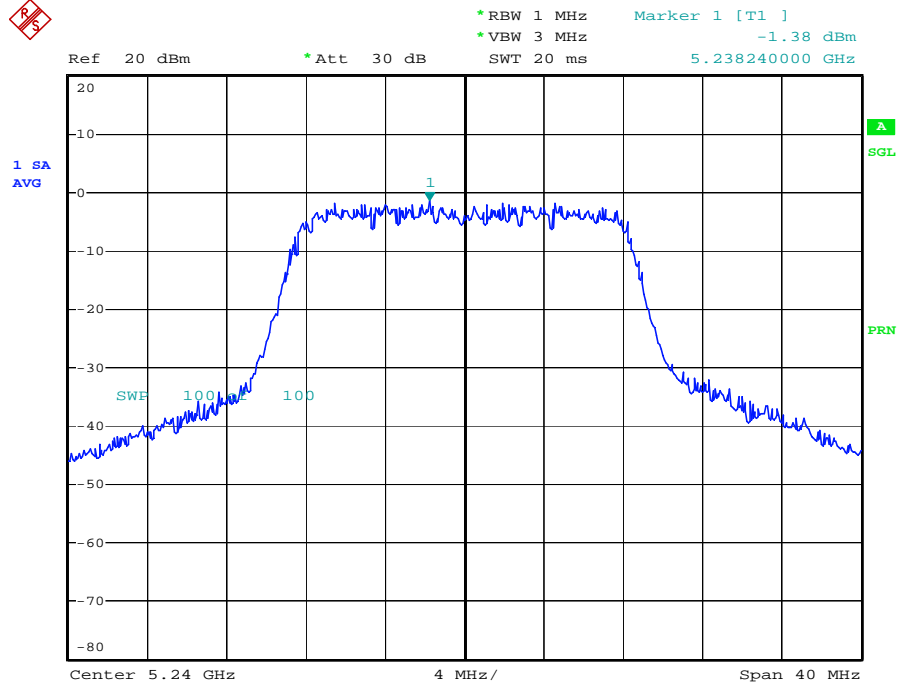

Date: 23.OCT.2004 12:39:38

Channel: 05 / 5260 MHz

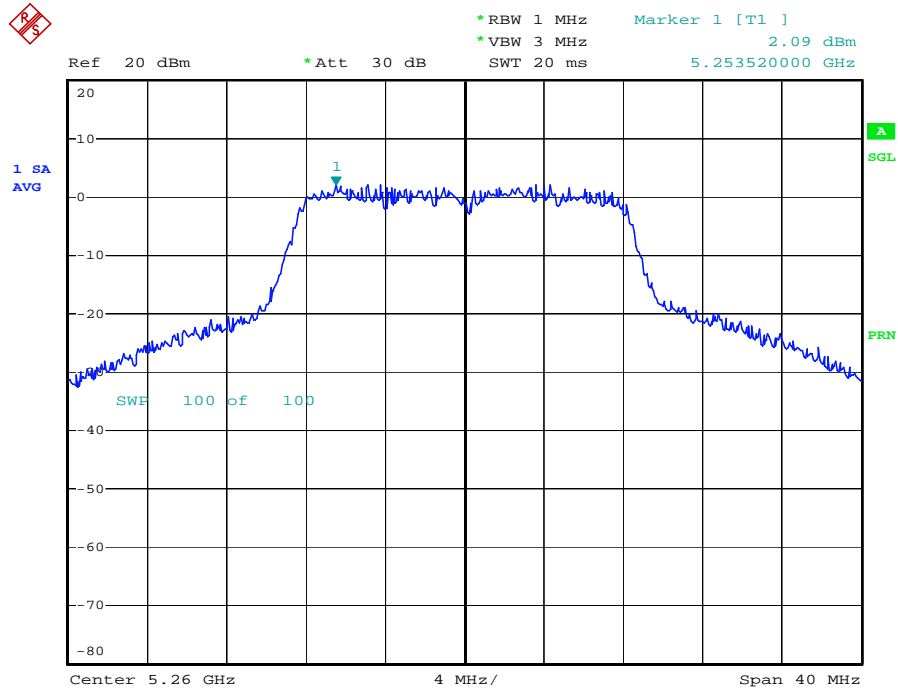

Date: 23.OCT.2004 12:40:25



Channel: 06 / 5280 MHz

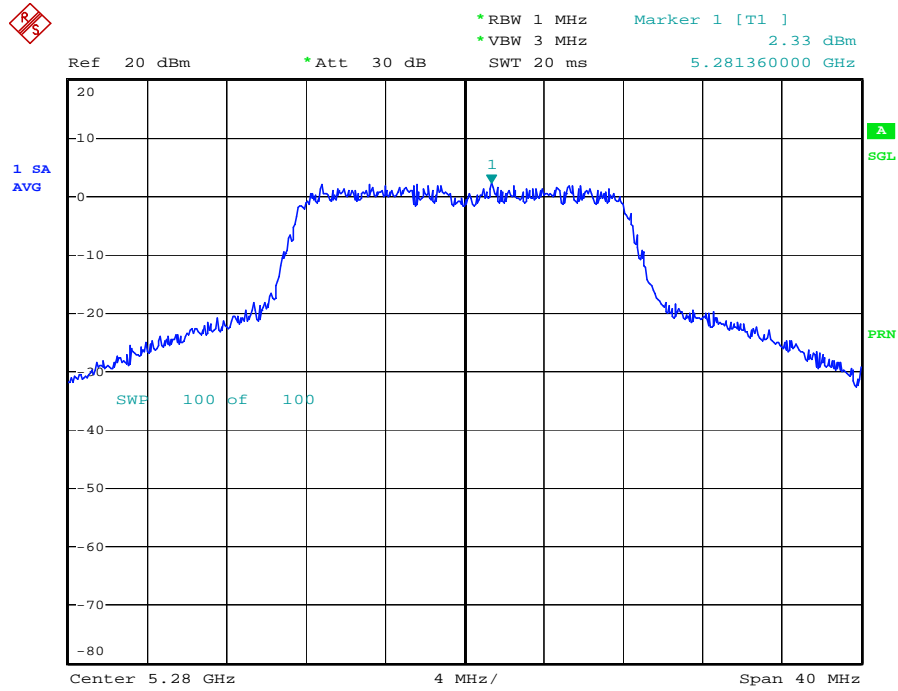

Channel: 08 / 5320 MHz

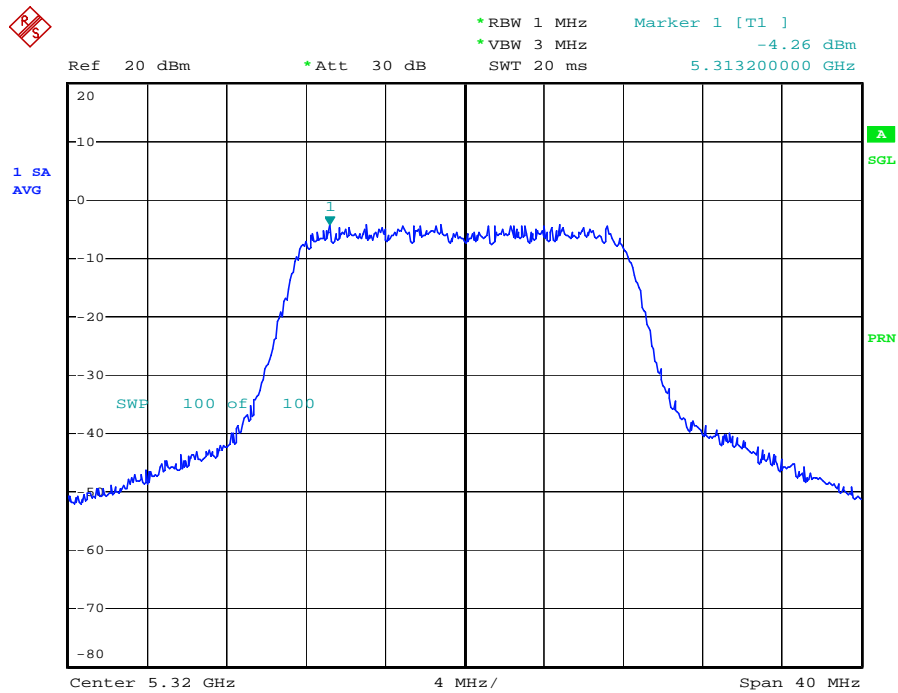



Channel: 09 / 5745 MHz

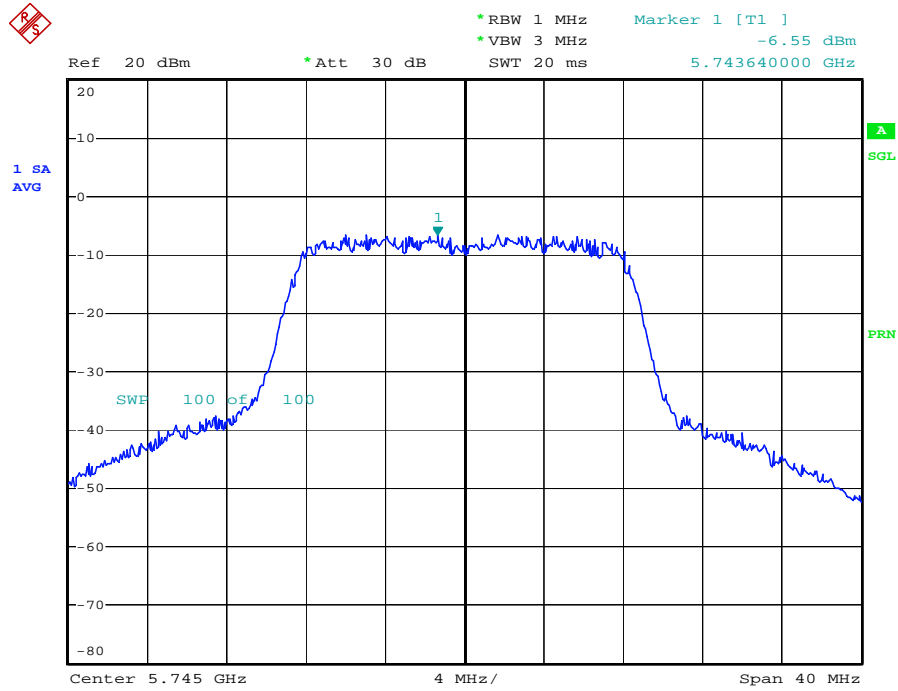

Date: 23.OCT.2004 12:45:00

Channel: 10 / 5765 MHz

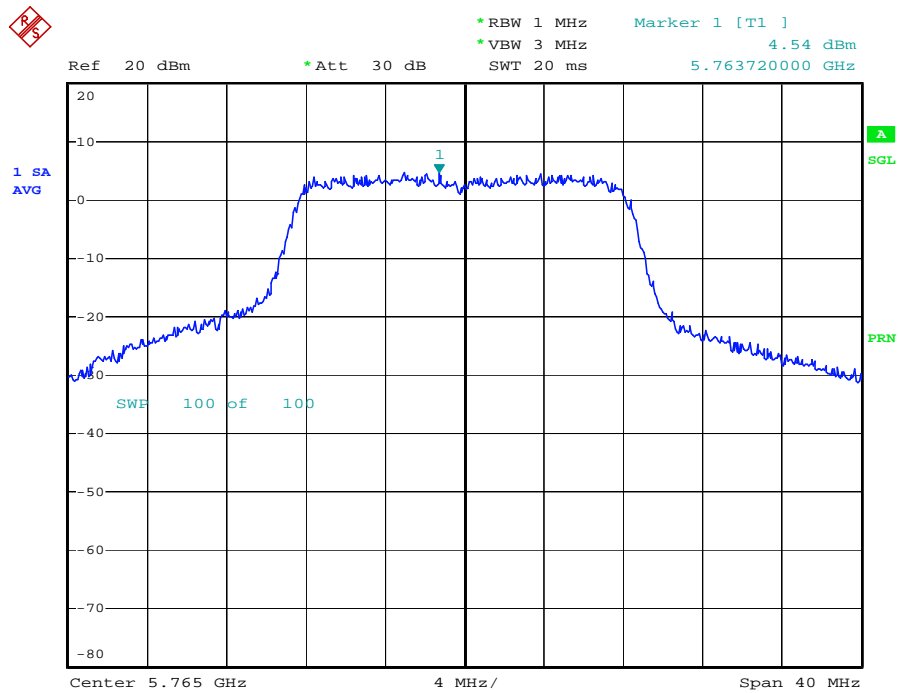

Date: 23.OCT.2004 12:48:51



Channel: 12 / 5805 MHz

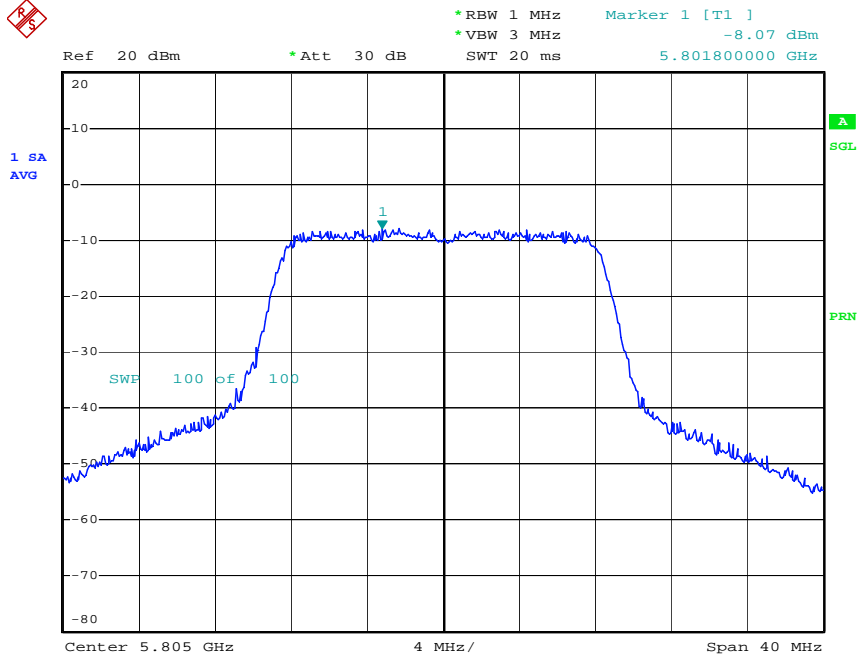

Date: 23.OCT.2004 12:49:37

Normal Mode (Mode 4)

Channel: 01 / 5180 MHz

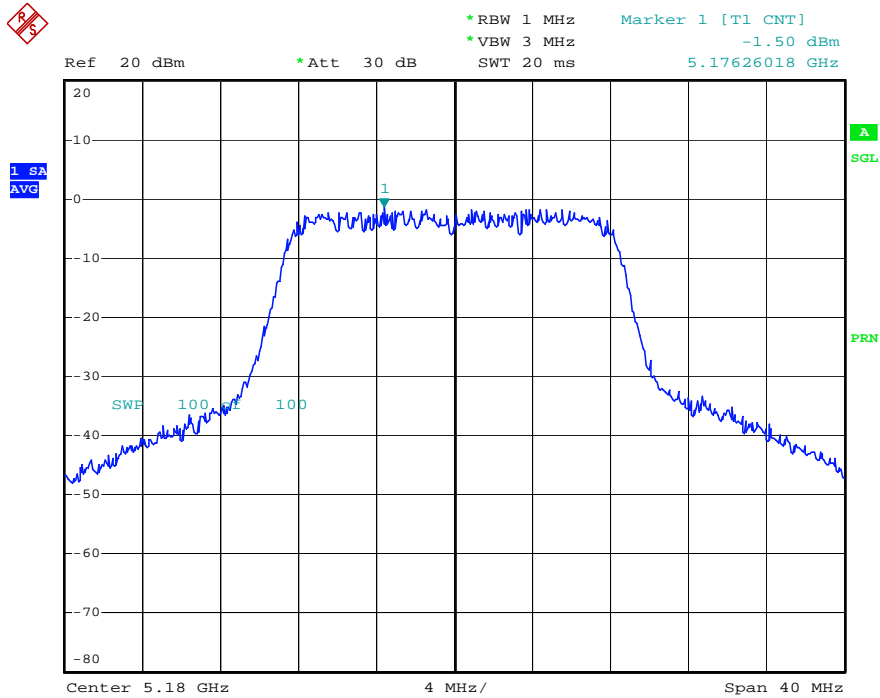

Date: 22.NOV.2004 15:20:41



Channel: 02 / 5200 MHz

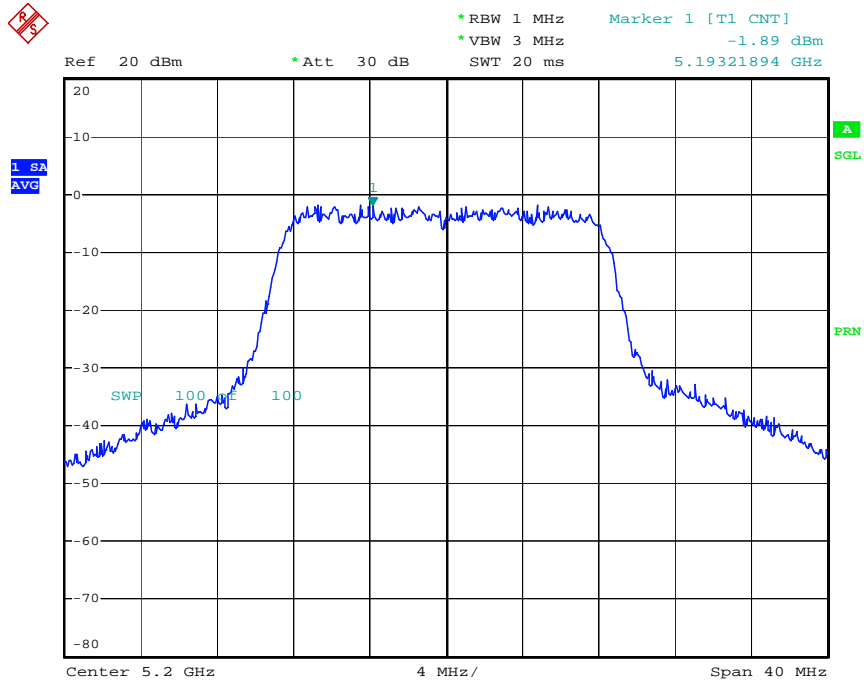

Channel: 04 / 5240 MHz

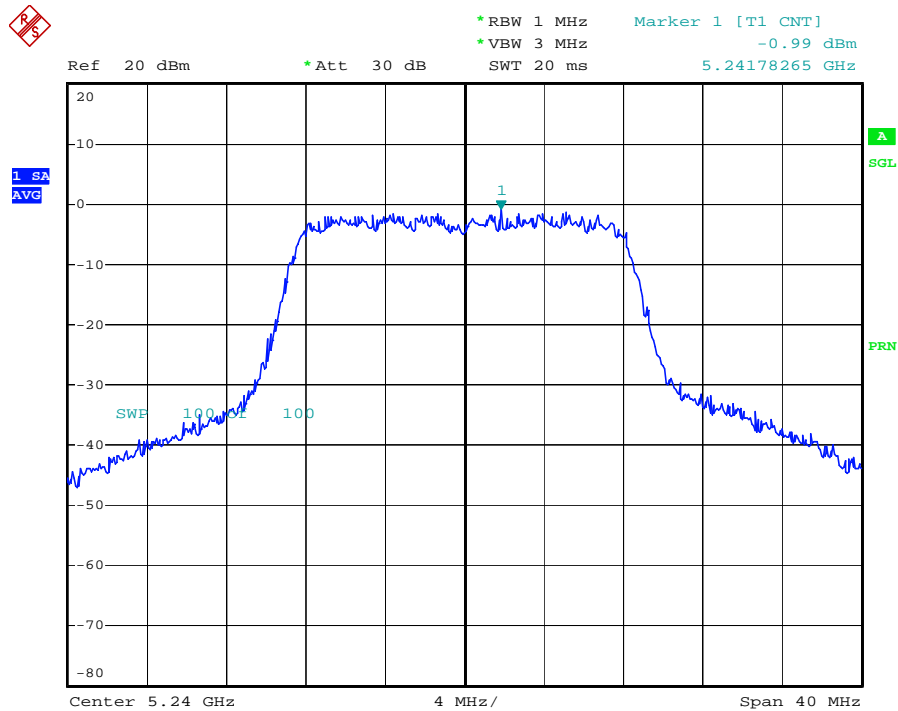



Channel: 05 / 5260 MHz

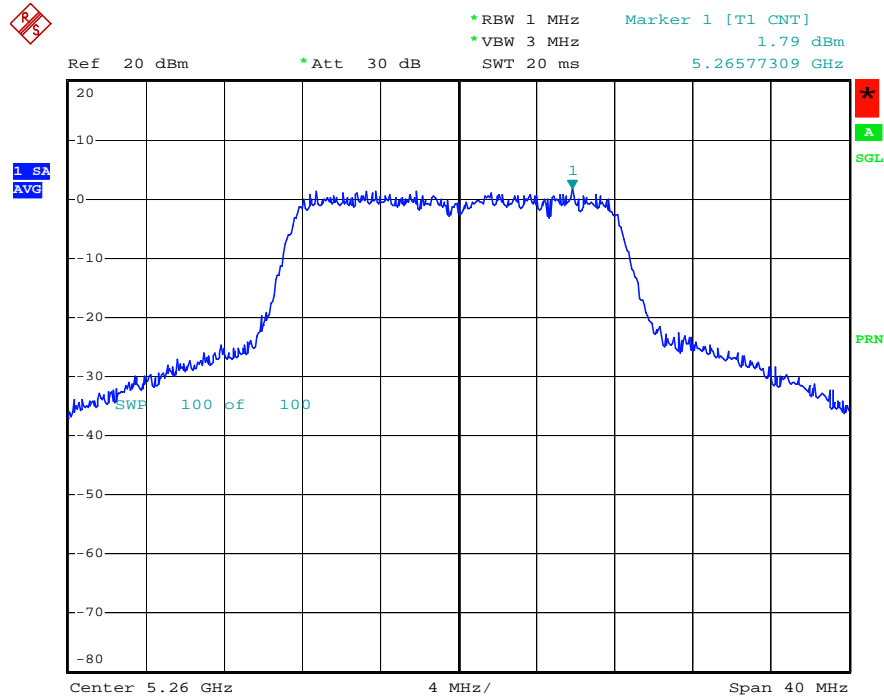

Date: 22.NOV.2004 15:45:17

Channel: 06 / 5280 MHz

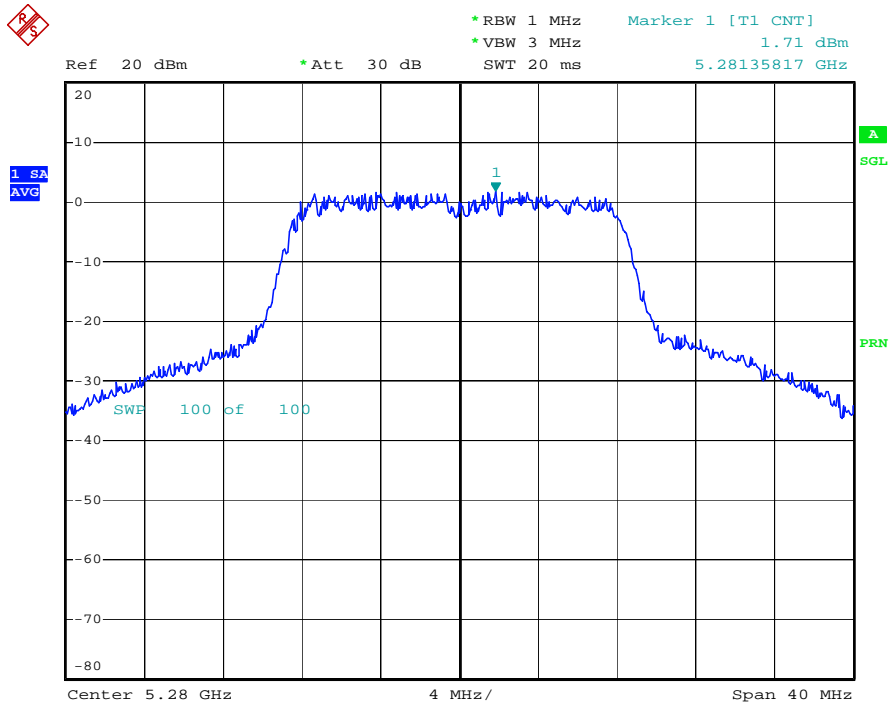

Date: 22.NOV.2004 15:48:17



Channel: 08 / 5320 MHz

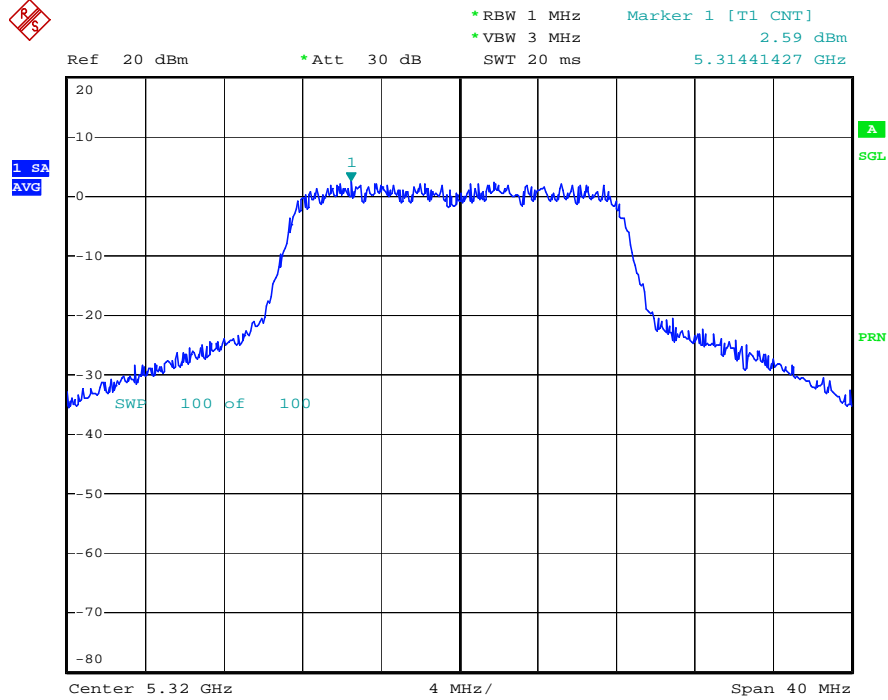

Date: 22.NOV.2004 15:49:05

Channel: 09 / 5745 MHz

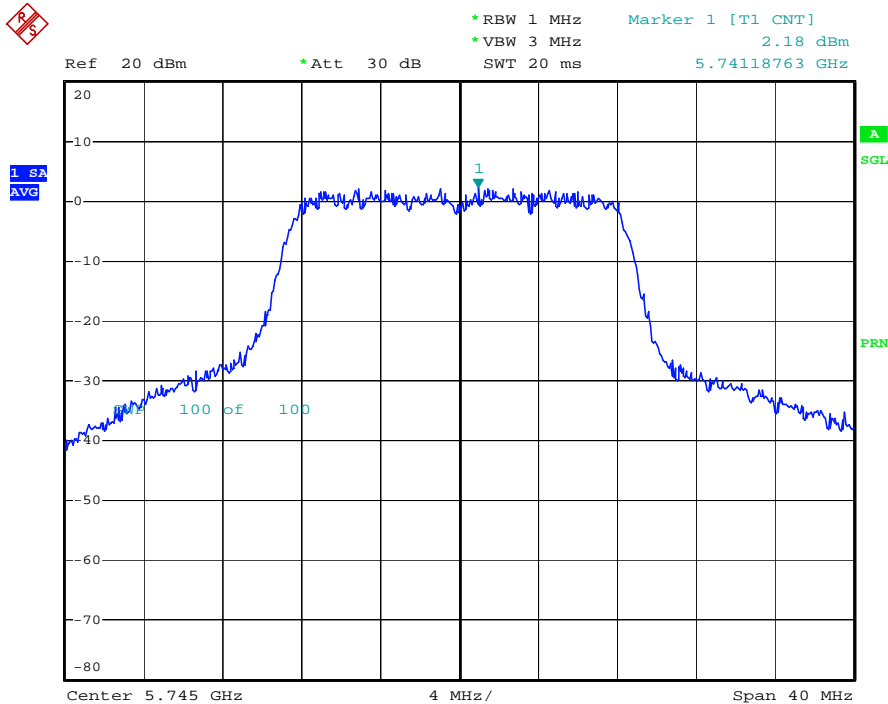

Date: 22.NOV.2004 15:50:07



Channel: 10 / 5765 MHz

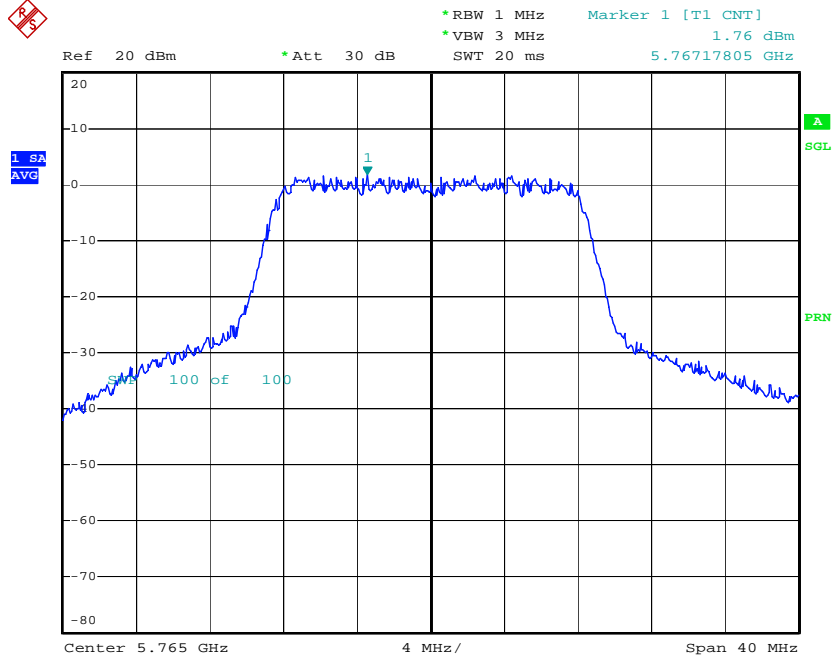

Date: 22.NOV.2004 15:50:53

Channel: 12 / 5805 MHz

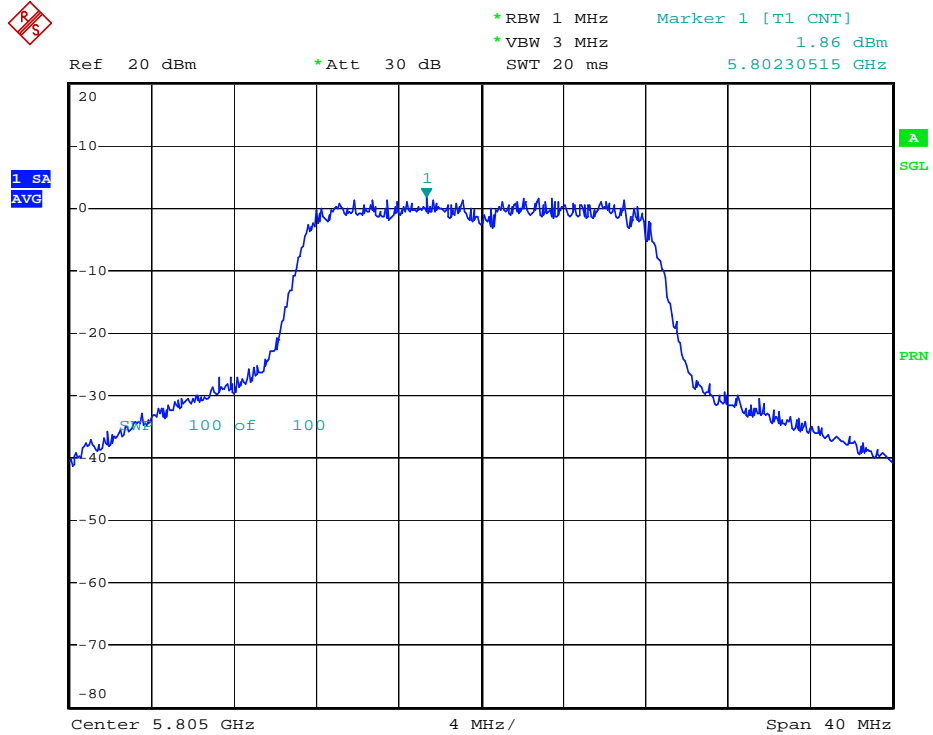

Date: 22.NOV.2004 15:51:44



Turbo Mode (Mode 1 ~ Mode 3)

Channel: 01 / 5210 MHz

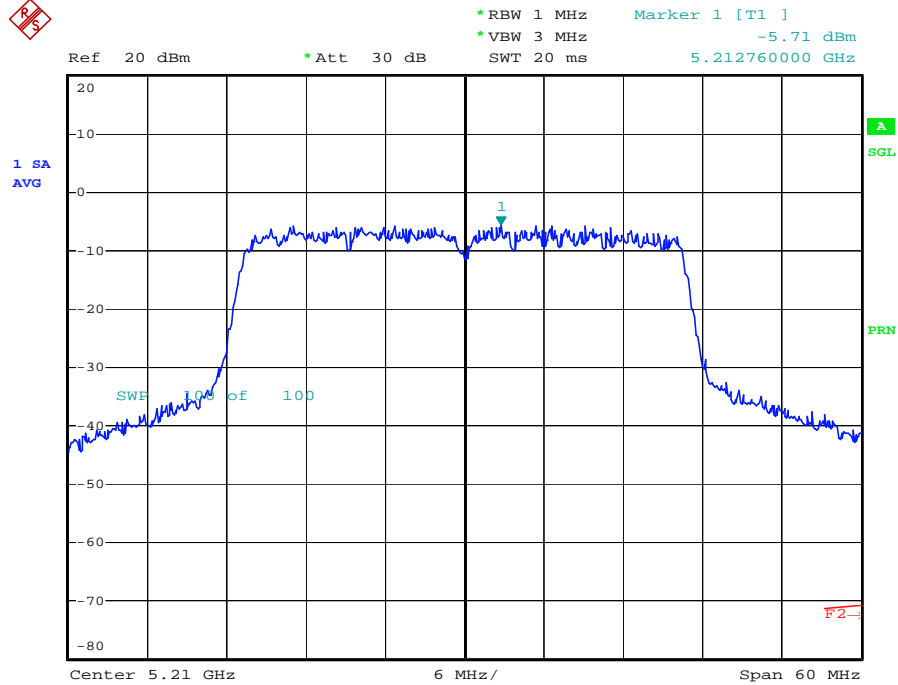

Date: 23.OCT.2004 12:21:57

Channel: 02 / 5250 MHz

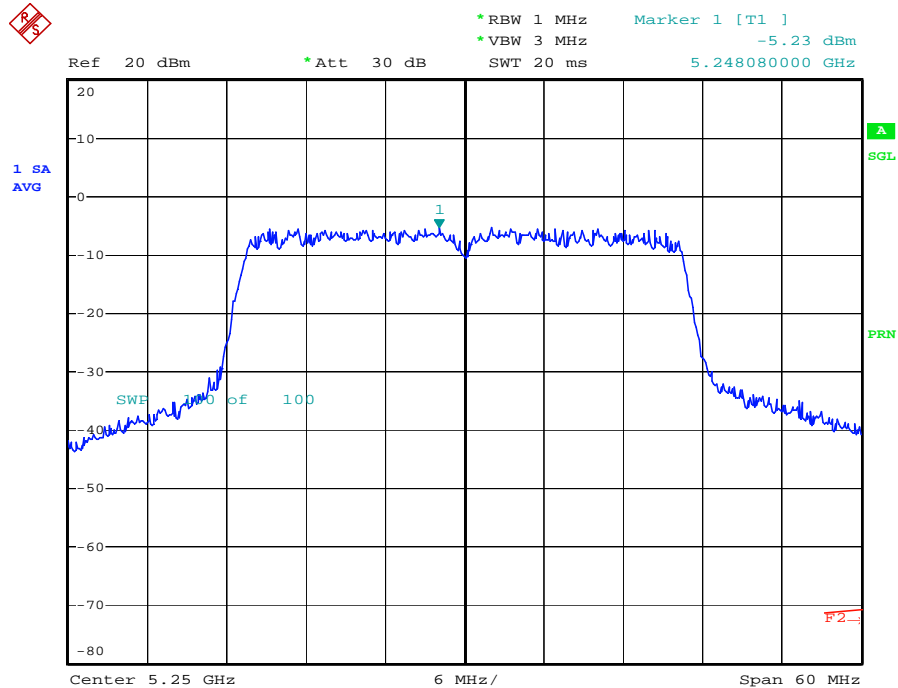

Date: 23.OCT.2004 12:23:10



Channel: 03 / 5290 MHz

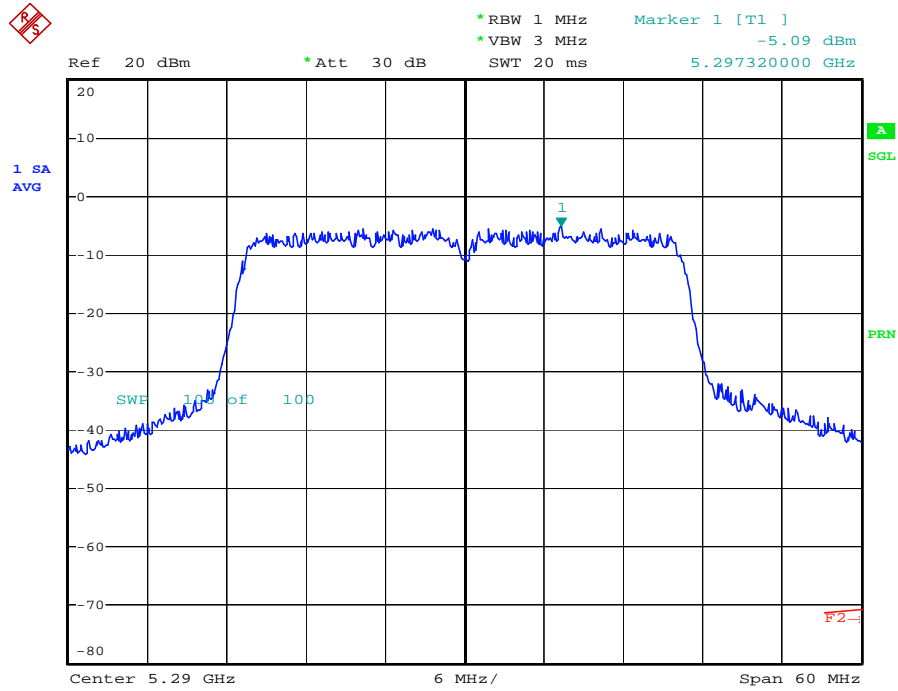

Date: 23.OCT.2004 12:23:51

Channel: 04 / 5760 MHz

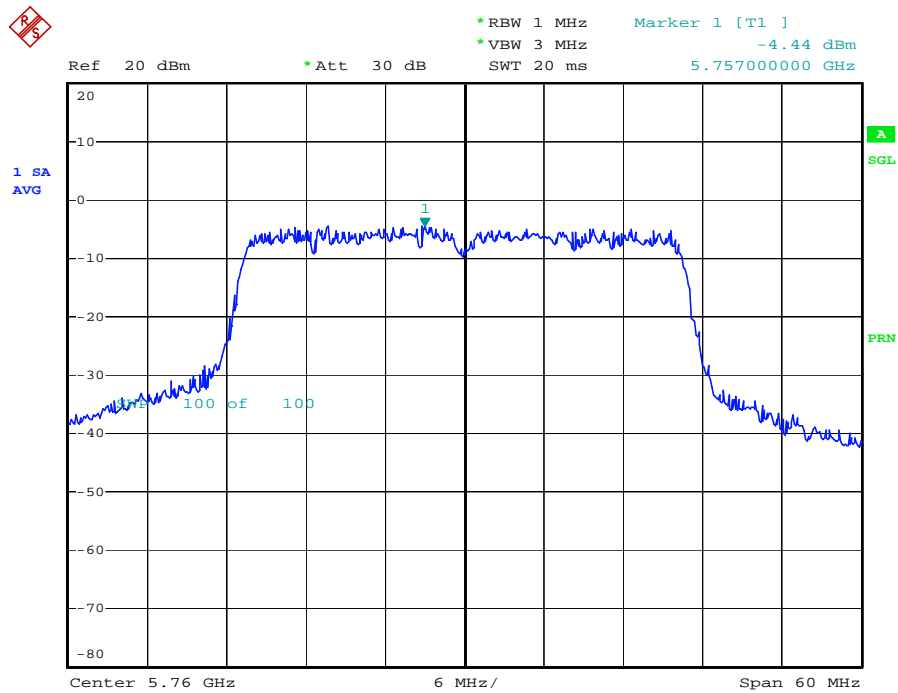

Date: 23.OCT.2004 12:27:46



Channel: 05 / 5800 MHz

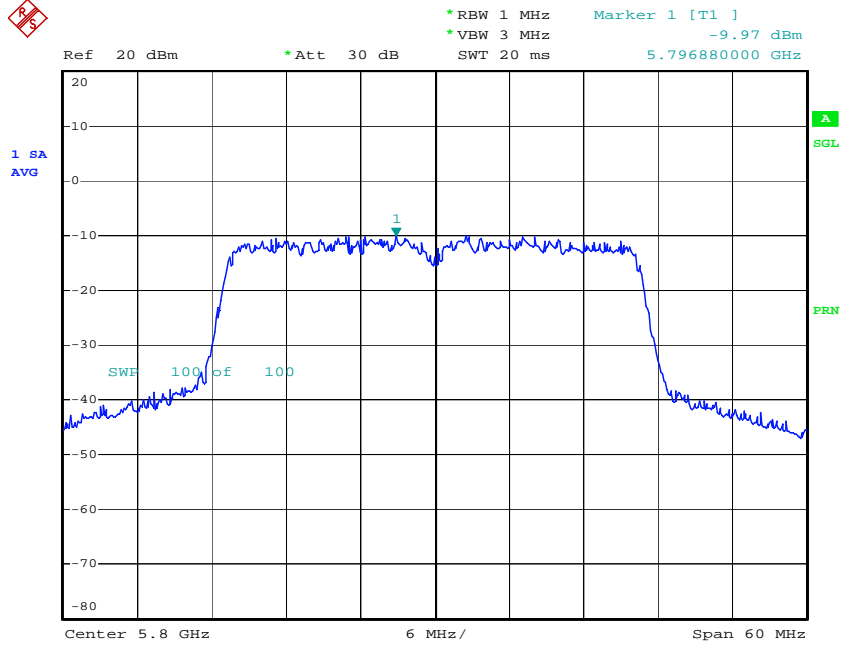

Date: 23.OCT.2004 12:28:56

Turbo Mode (Mode 4)

Channel: 01 / 5210 MHz

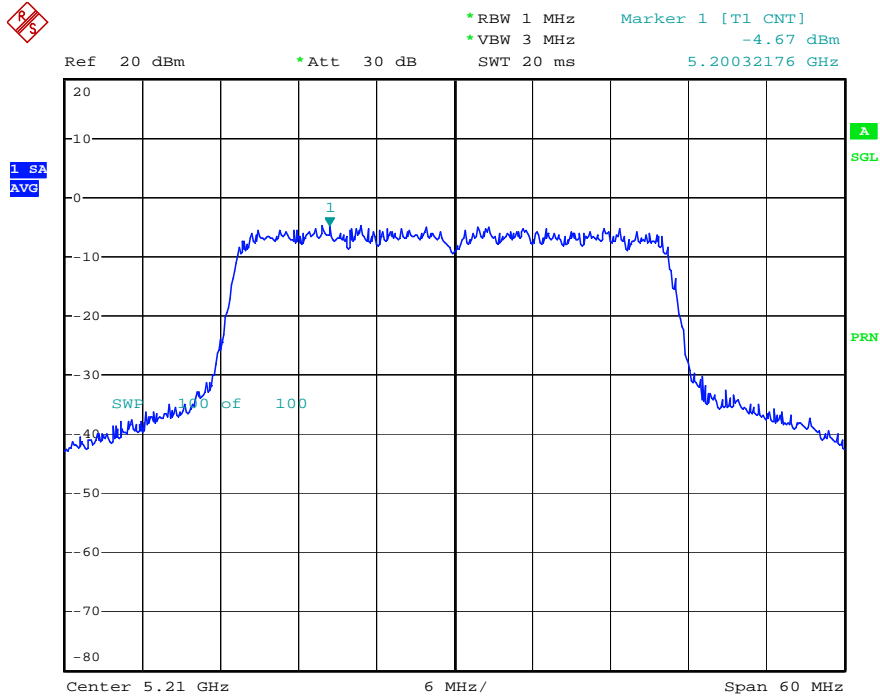

Date: 22.NOV.2004 15:52:47



Channel: 02 / 5250 MHz

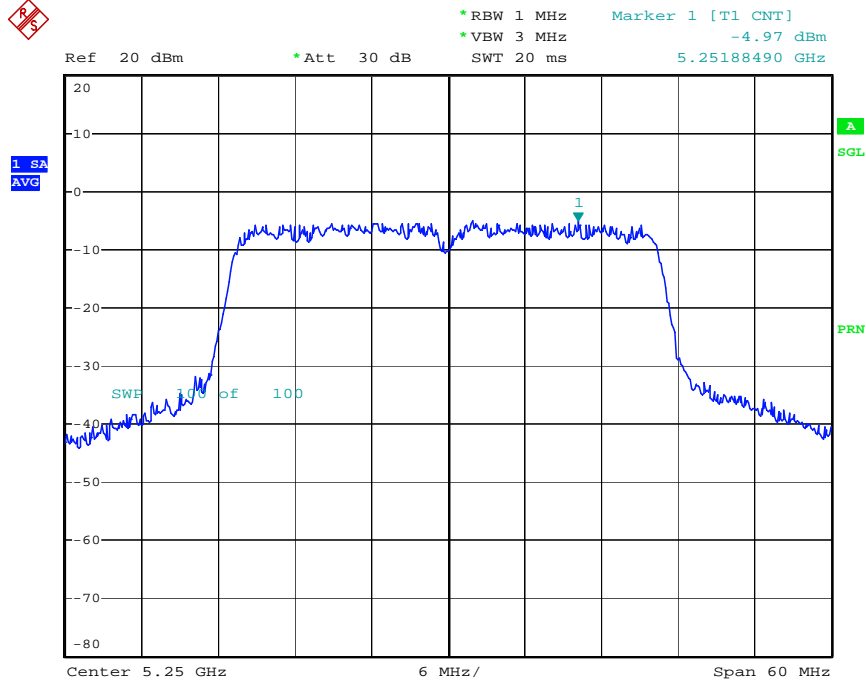

Date: 22.NOV.2004 15:53:34

Channel: 03 / 5290 MHz

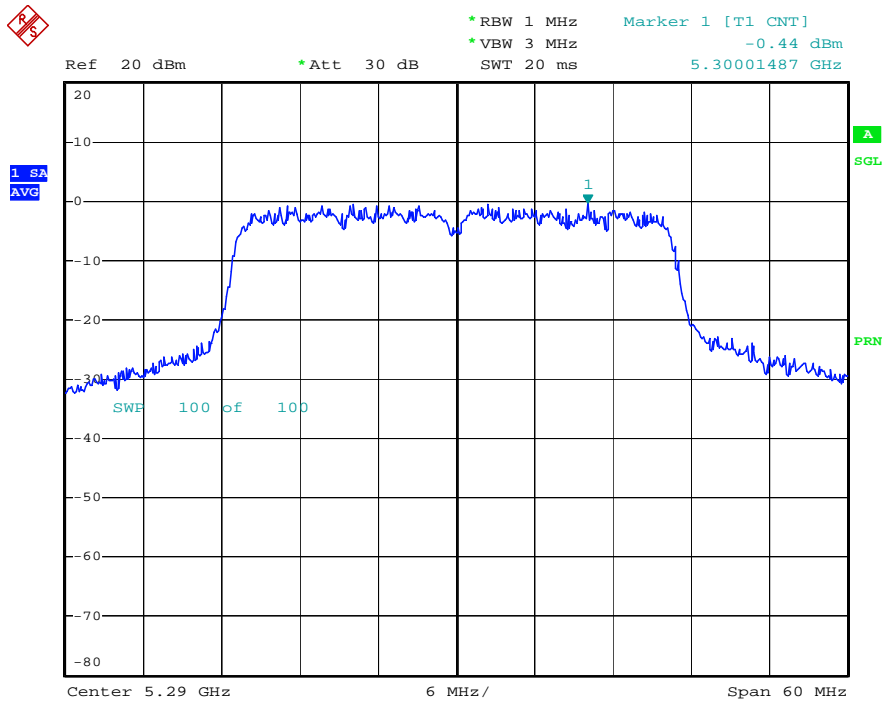

Date: 22.NOV.2004 15:54:29



Channel: 04 / 5760 MHz

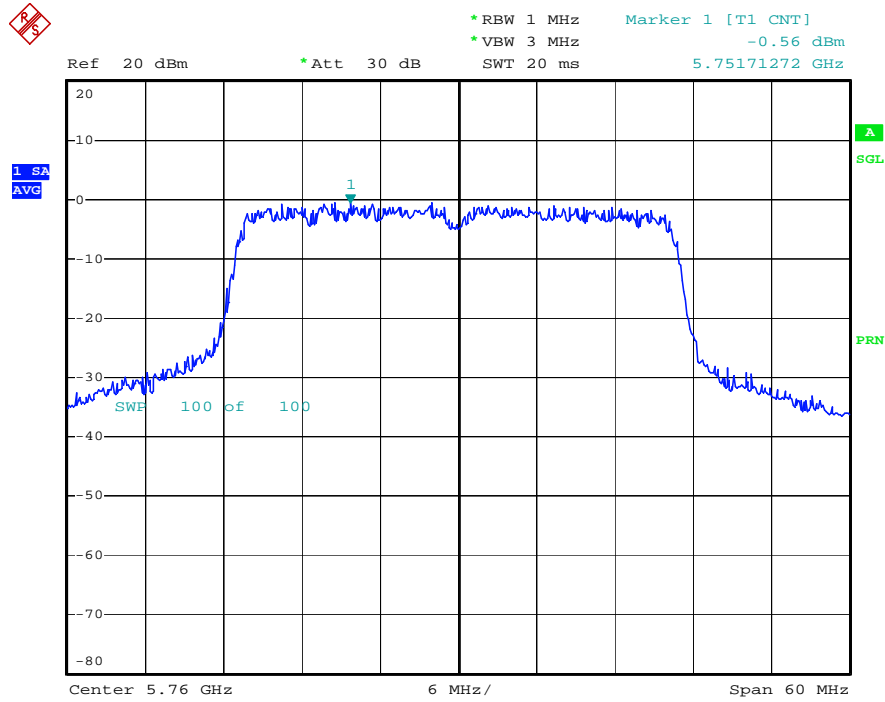

Date: 22.NOV.2004 15:55:30

Channel: 05 / 5800 MHz

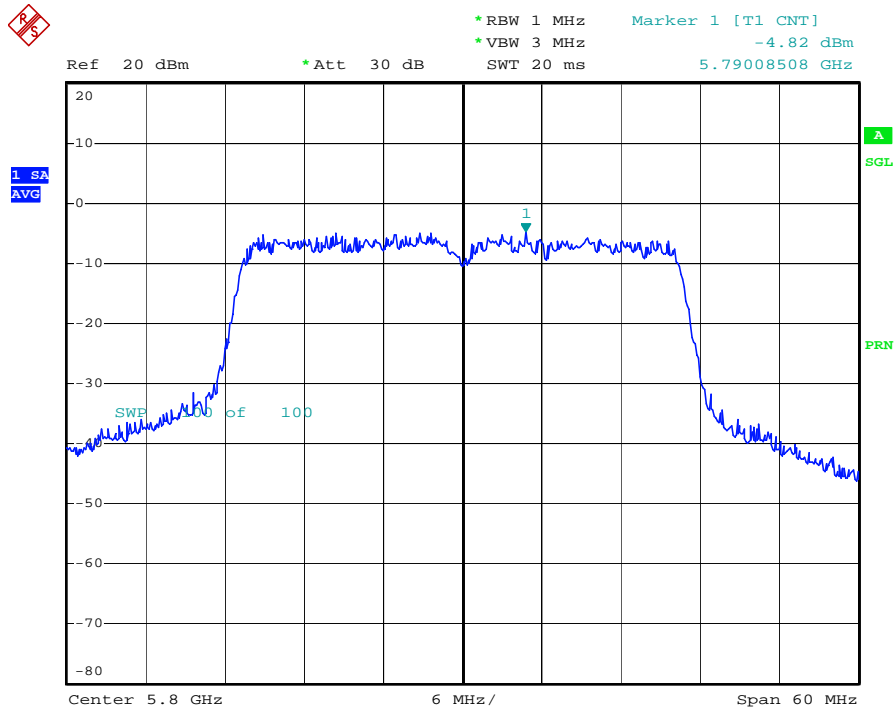

Date: 22.NOV.2004 15:56:24

5.4. Ratio of the Peak Excursion

5.4.1. Measuring Instruments

Item 18 of the table is on section 6.

5.4.2. Test Procedures

1. The transmitter output is connected to the spectrum analyzer through an attenuator.
2. Trace 1: Set RBW of spectrum analyzer to 1000kHz and VBW to 3000kHz.
3. Use peak detector mode, Max-hold and search the peak of trace 1.
4. Trace 2: Set RBW of spectrum analyzer to 1000kHz and VBW to 3000kHz.
5. Use sample detector mode, trace max-hold and search the peak of trace 2
6. The delta limits is 13dB between trace 1 and trace 2 of the peak value.

5.4.3. Test Setup Layout

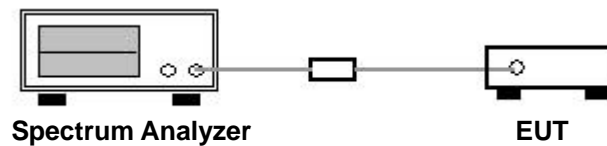

5.4.4. Test Result of conducted peak power spectral density

- Temperature: 26°C
- Relative Humidity: 64%
- Duty Cycle of the Equipment During the Test: 100.00%
- Test Engineer: Sam Lee

Normal Mode

Channel	Frequency (MHz)	Peak Excursion (dB)	Max. Limits (dB)
01	5180 MHz	5.31	13
02	5200 MHz	4.91	13
04	5240 MHz	5.14	13
05	5260 MHz	4.50	13
06	5280 MHz	4.88	13
08	5320 MHz	4.74	13
09	5745 MHz	5.24	13
10	5765 MHz	4.23	13
12	5805 MHz	4.27	13



Turbo Mode

Channel	Frequency (MHz)	Peak Excursion (dB)	Max. Limits (dB)
01	5210 MHz	4.66	13
02	5250 MHz	5.62	13
03	5290 MHz	4.87	13
04	5760 MHz	5.12	13
05	5800 MHz	3.90	13



Normal Mode

Channel: 01 / 5180 MHz

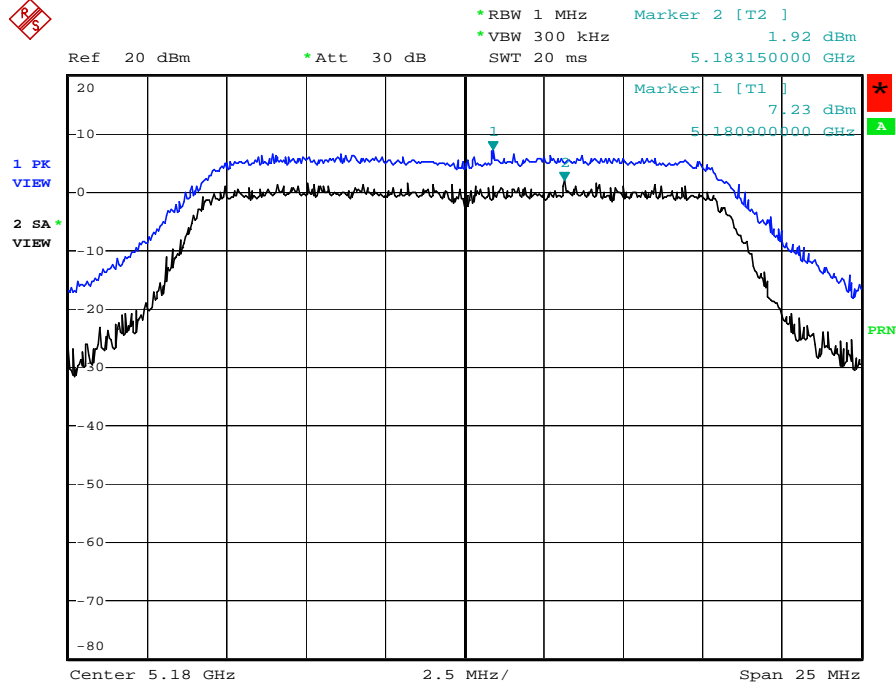

Date: 23.OCT.2004 14:44:39

Channel: 02 / 5200 MHz

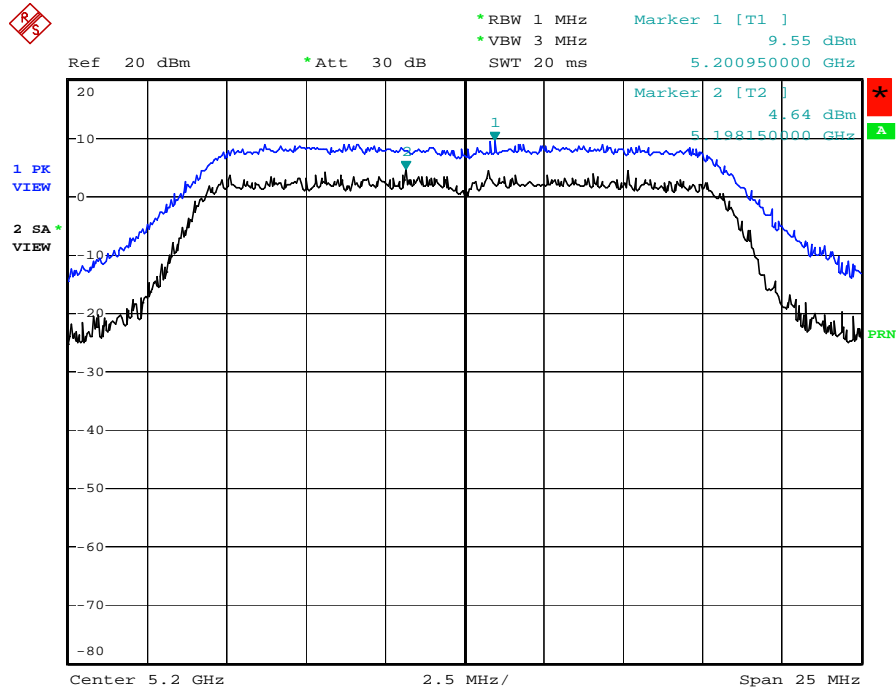

Date: 23.OCT.2004 14:47:03



Channel: 04 / 5240 MHz

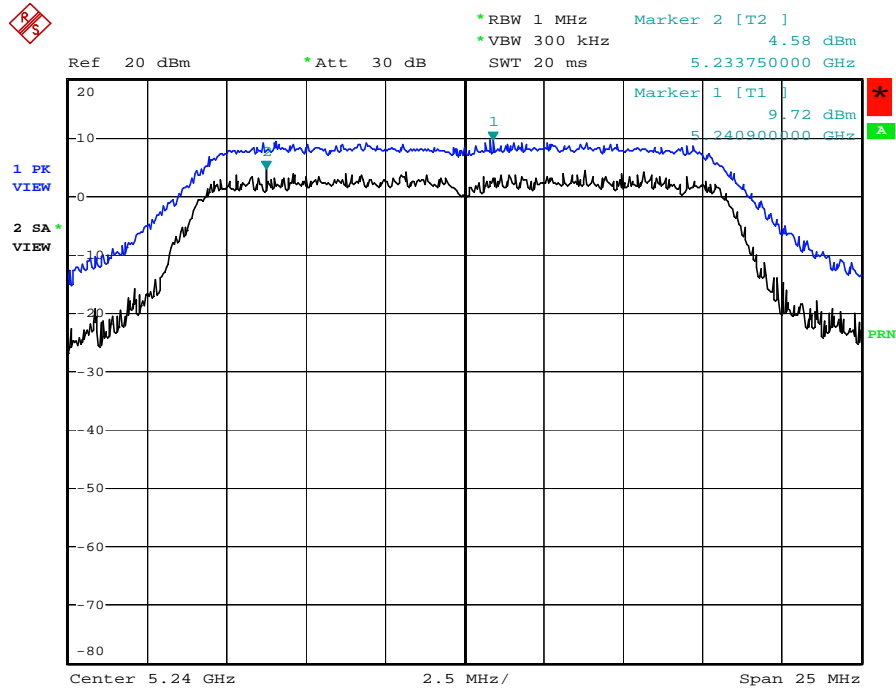

Date: 23.OCT.2004 14:48:03

Channel: 05 / 5260 MHz

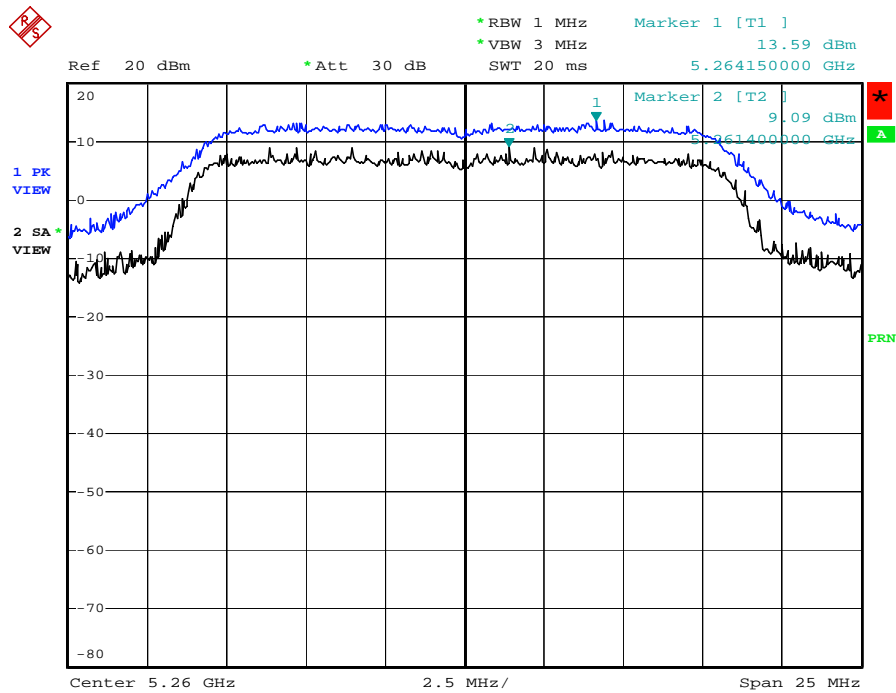

Date: 23.OCT.2004 14:50:30



Channel: 06 / 5280 MHz

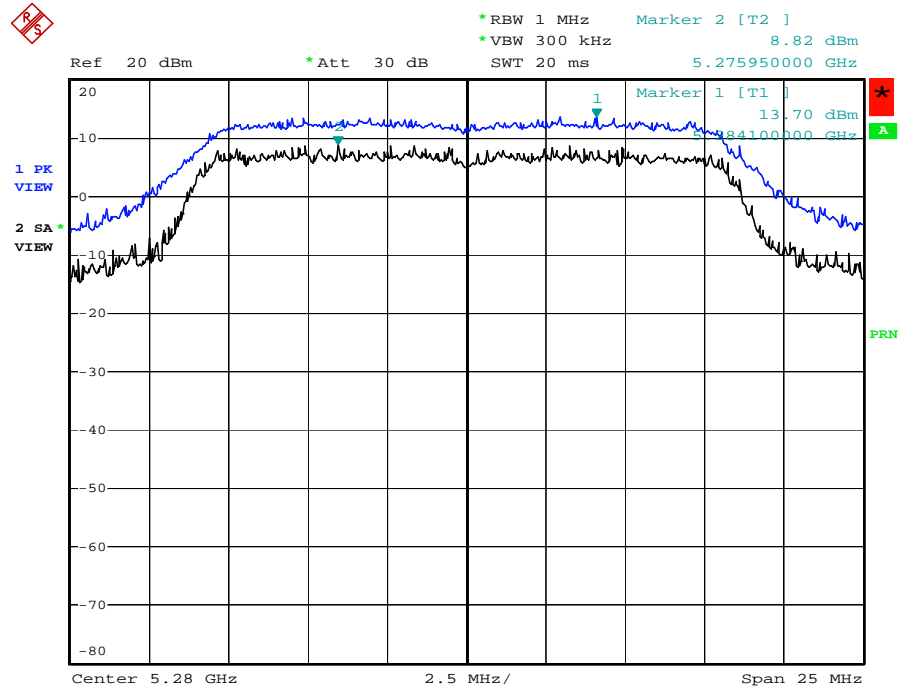

Date: 23.OCT.2004 14:51:51

Channel: 08 / 5320 MHz

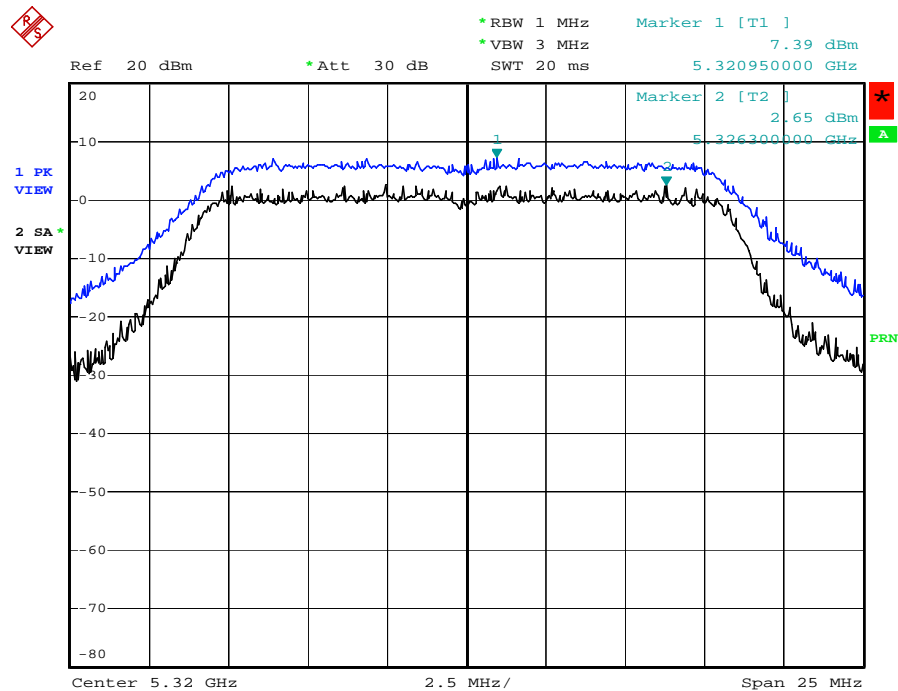

Date: 23.OCT.2004 14:53:37



Channel: 09 / 5745 MHz

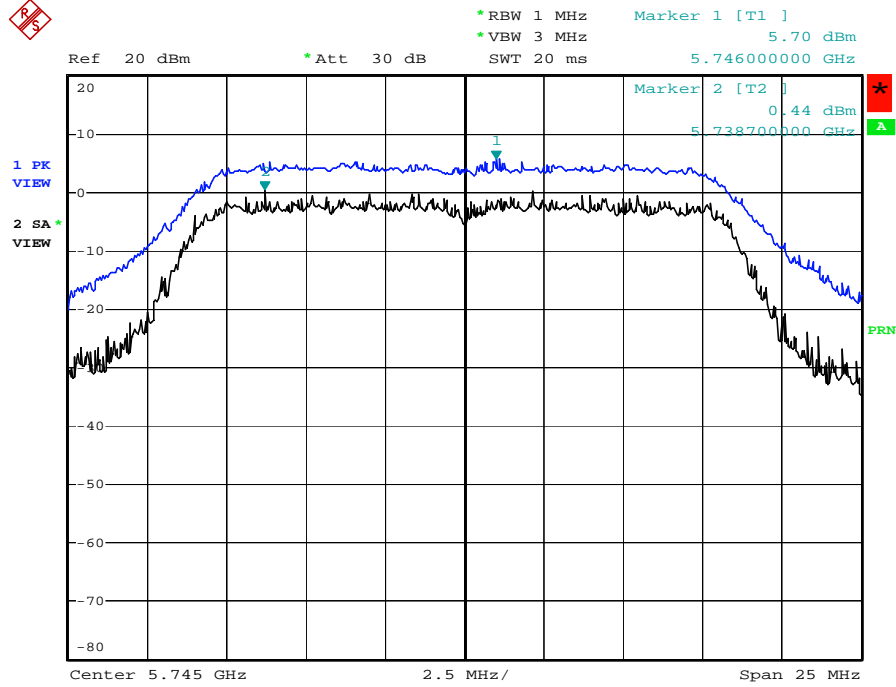

Date: 23.OCT.2004 15:03:37

Channel: 10 / 5765 MHz

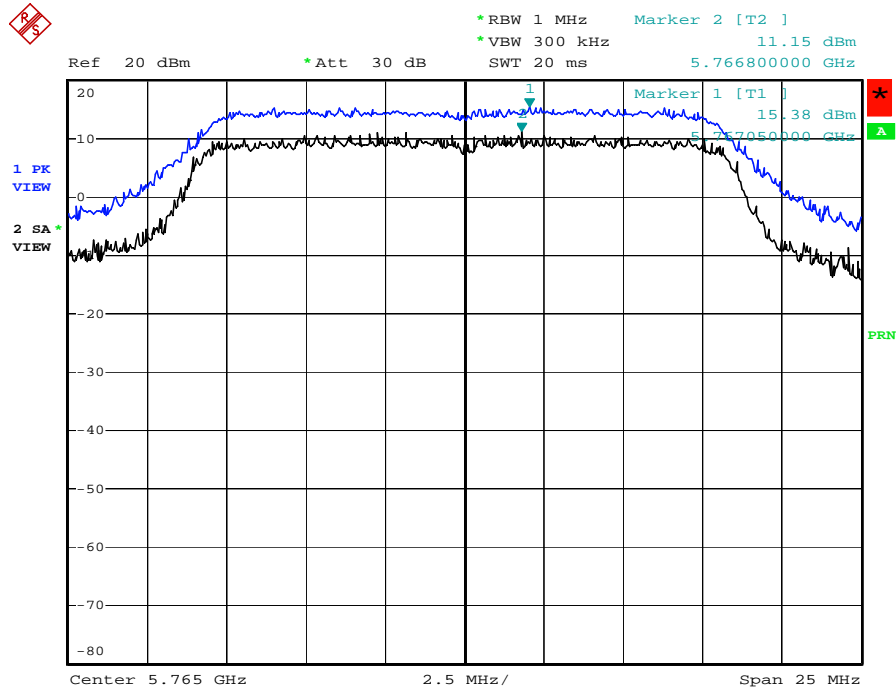

Date: 23.OCT.2004 15:05:15



Channel: 12 / 5805 MHz

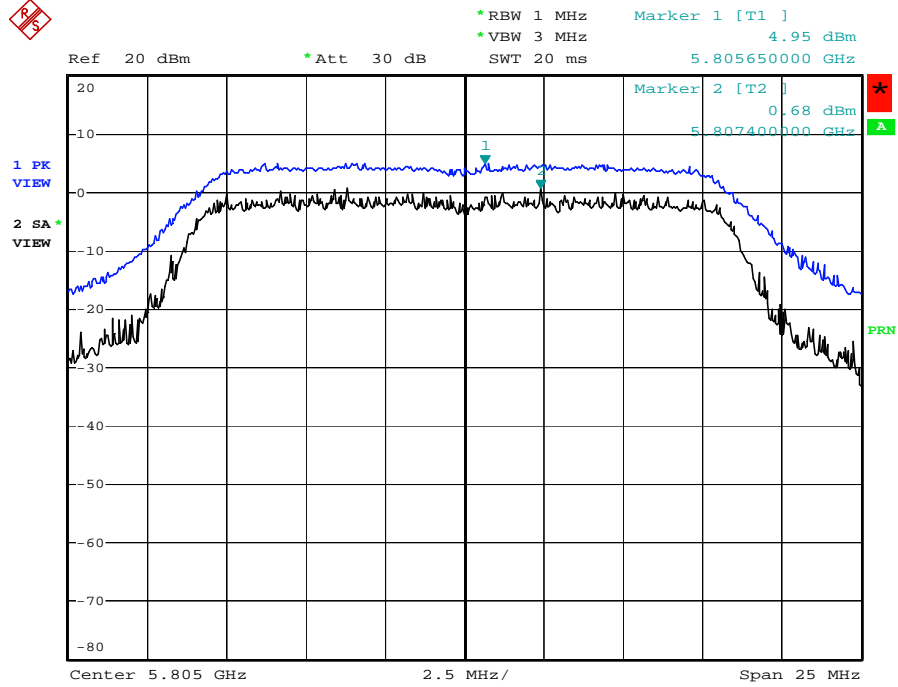

Date: 23.OCT.2004 15:10:18



Turbo Mode

Channel: 01 / 5210 MHz

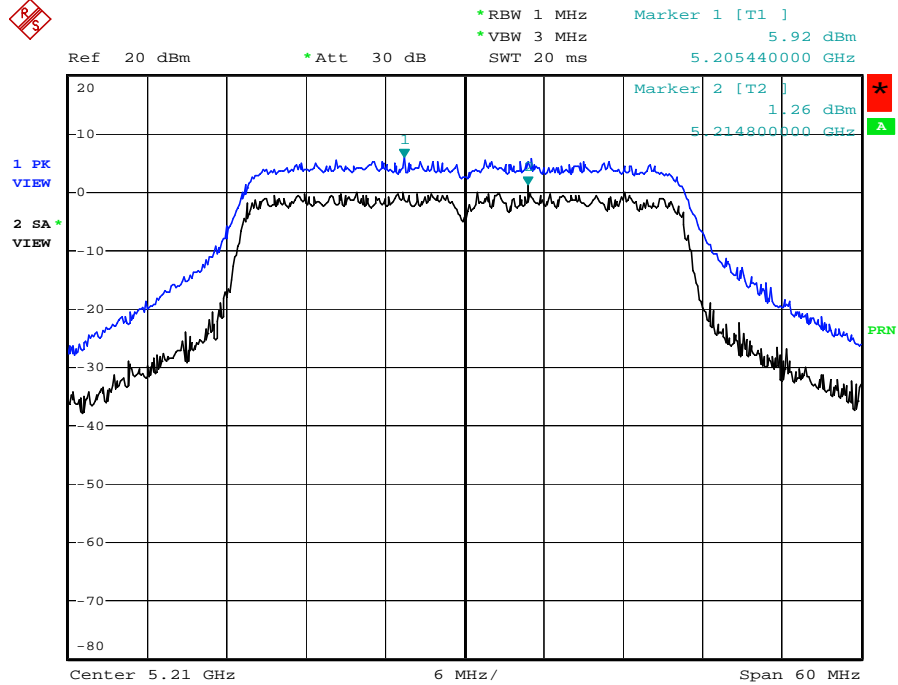

Date: 23.OCT.2004 14:39:38

Channel: 02 / 5250 MHz

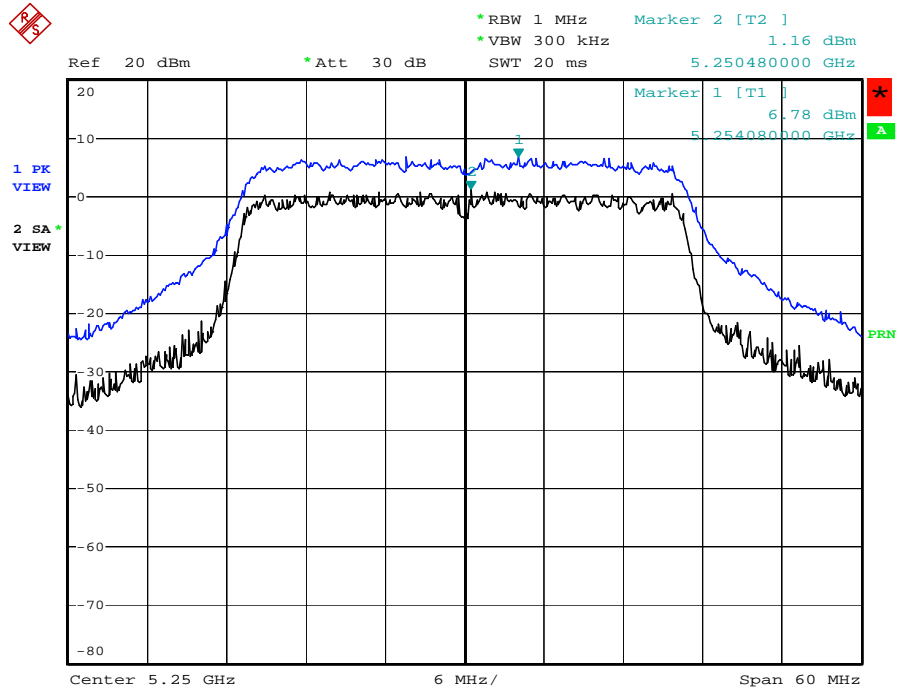

Date: 23.OCT.2004 14:38:25



Channel: 03 / 5290 MHz

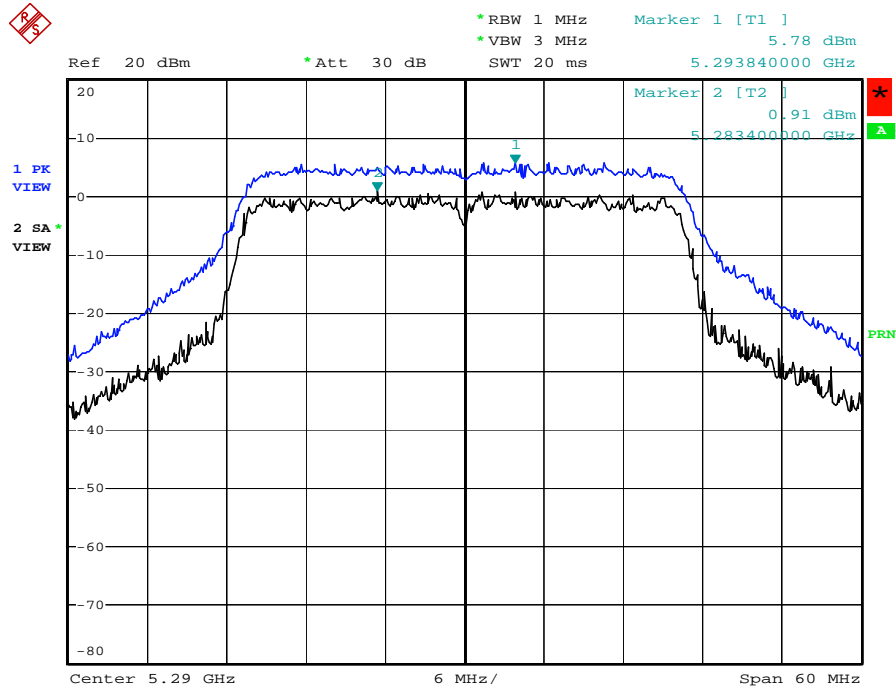

Date: 23.OCT.2004 14:36:35

Channel: 04 / 5760 MHz

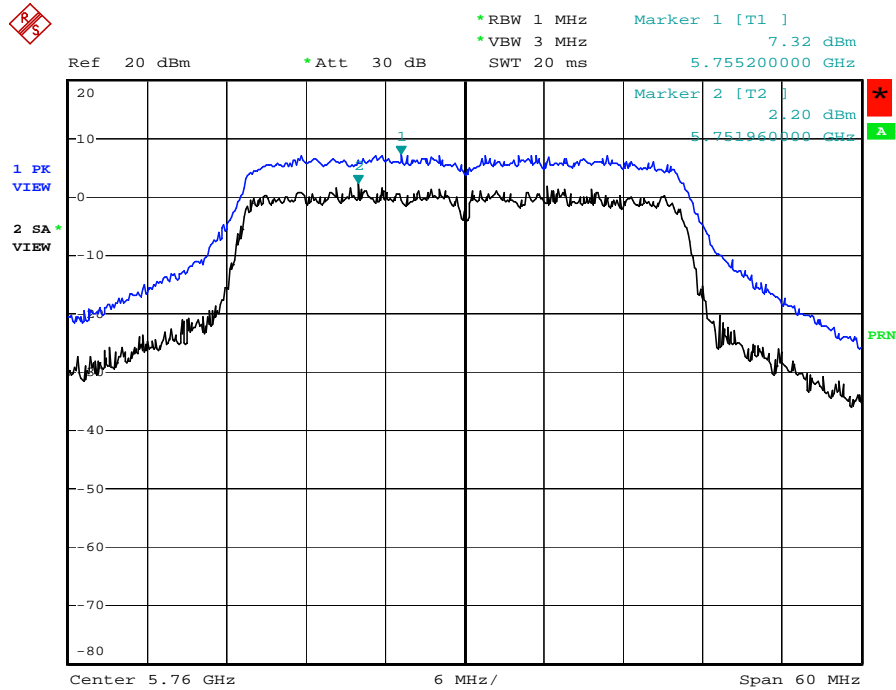

Date: 23.OCT.2004 14:28:47



Channel: 05 / 5800 MHz

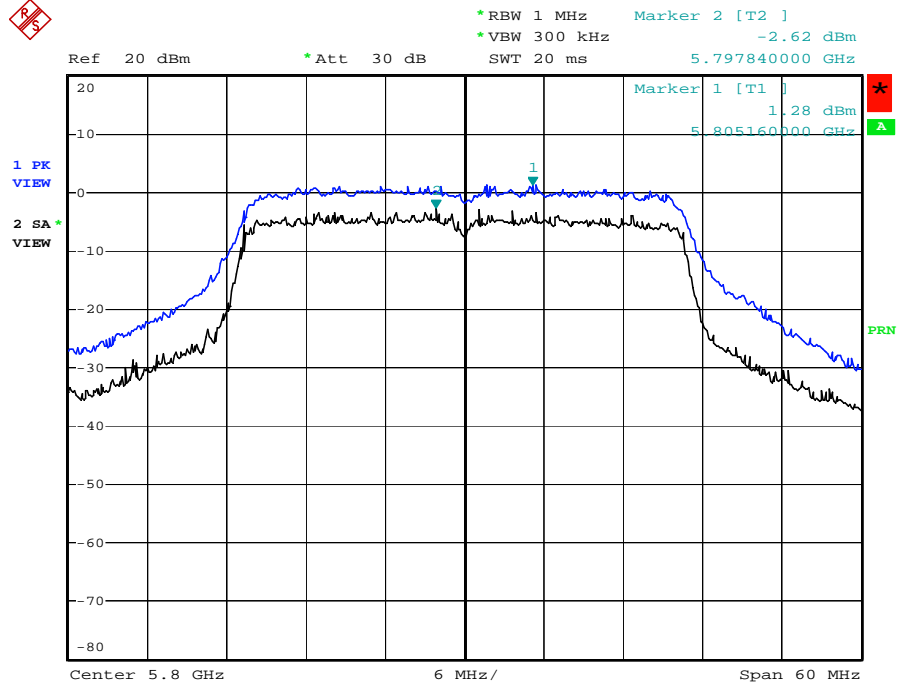

Date: 23.OCT.2004 14:24:05

5.5. Test of Band Edges Emission

5.5.1. Measuring Instruments

Please reference item 6~17 in chapter 6 for the instruments used for testing.

5.5.2. Test Procedures

1. Configure the EUT according to ANSI C63.4.
2. The EUT was placed on the top of the turntable 0.8 meter above ground.
3. The phase center of the receiving antenna mounted on the top of a height-variable antenna tower was placed 3 meters far away from the turntable.
4. The transmitter is set to the lowest channel of each band.
5. The turntable was rotated 360 degrees to determine the position of the highest radiation.
6. Set both RBW and VBW of spectrum analyzer to 1MHz with convenient frequency span including 1MHz bandwidth from lower band edge.
7. The height of the broadband receiving antenna was varied between one meter and four meters above ground to find the maximum emission field strength of both horizontal and vertical polarization. Record the maximum value of band-edge.
8. Remove the transmitter and replace it with a broadband substitution antenna.
9. With the substitution antennas at maximum polarized and with the signal generator tuned to a particular fundamental frequency, raise and lower the test antenna to obtain a maximum reading at the spectrum analyzer. Adjust the level of the signal generator output until the previously recorded maximum reading (item 6). This should be done carefully repeating the adjustment of the test antenna and generator output.
10. $P_d(\text{dBm}) = P_g(\text{dBm}) - \text{cable loss (dB)} + \text{antenna gain (dBi)}$. P_d is the dipole equivalent power and P_g is the generator output power into the substitution antenna.
11. The lowest and highest channels of band edges of each band emission was measured and recorded.

5.5.3. Test Setup Layout

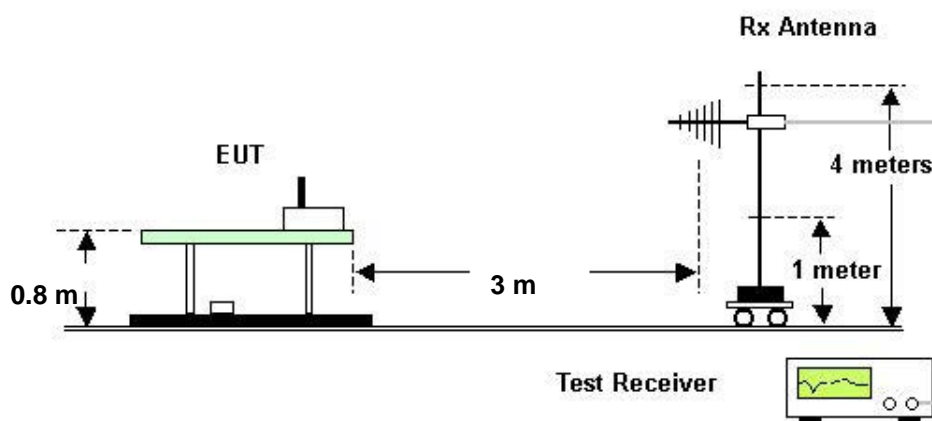



5.5.4. Test Result

- Temperature: 26°C
- Relative Humidity: 64%
- Duty Cycle of the Equipment During the Test: 100.00%
- Test Engineer: Sam Lee

Normal Mode

Ant. No.	Gain (dBi)	Freq. Band (MHz)	Freq. (MHz)	Level* (dBm/MHz)	Margin (dB)	Limit (dBm/MHz)
1	4.00	5150~5250	5149.6	-32.37	-5.37	-27
1	4.00	5250~5350	5350.0	-34.74	-7.74	-27
1	4.00	5725~5825	5714.4	-32.10	-5.10	-27
1	4.00	5725~5825	5724.8	-22.88	-5.88	-17
1	4.00	5725~5825	5826.0	-25.74	-8.74	-17
1	4.00	5725~5825	5837.0	-32.69	-5.69	-27
2	6.00	5150~5250	5149.4	-30.26	-3.26	-27
2	6.00	5250~5350	5361.8	-30.67	-3.67	-27
2	6.00	5725~5825	5713.8	-30.46	-3.46	-27
2	6.00	5725~5825	5724.8	-20.92	-3.92	-17
2	6.00	5725~5825	5825.4	-21.92	-4.92	-17
2	6.00	5725~5825	5839.2	-30.85	-3.85	-27
3	8.00	5150~5250	5150.0	-27.61	-0.61	-27
3	8.00	5250~5350	5356.2	-28.70	-1.70	-27
3	8.00	5725~5825	5715.0	-27.98	-0.98	-27
3	8.00	5725~5825	5724.8	-18.60	-1.60	-17
3	8.00	5725~5825	5825.8	-20.64	-3.64	-17
3	8.00	5725~5825	5835.2	-28.38	-1.38	-27
4	2.50	5150~5250	5149.2	-29.60	-2.60	-27
4	2.50	5250~5350	5358.0	-27.55	-0.55	-27
4	2.50	5725~5825	5714.6	-27.31	-0.31	-27



Ant. No.	Gain (dBi)	Freq. Band (MHz)	Freq. (MHz)	Level* (dBm/MHz)	Margin (dB)	Limit (dBm/MHz)
4	2.50	5725~5825	5725.0	-17.60	-0.60	-17
4	2.50	5725~5825	5825.8	-22.81	-5.81	-17
4	2.50	5725~5825	5836.4	-27.00	-10.00	-27

Level*: The max EIRP emission in the band-edge.



Turbo Mode

Ant. No.	Gain (dBi)	Freq. Band (MHz)	Freq. (MHz)	Level* (dBm/MHz)	Margin (dB)	Limit (dBm/MHz)
1	4.00	5150~5250	5147.2	-34.38	-7.38	-27
1	4.00	5250~5350	5350.6	-32.36	-5.35	-27
1	4.00	5725~5825	5724.6	-20.68	-3.68	-27
1	4.00	5725~5825	5715.0	-30.58	-3.58	-17
1	4.00	5725~5825	5825.2	-21.42	-4.42	-17
1	4.00	5725~5825	5836.0	-31.11	-4.11	-27
2	6.00	5150~5250	5149.6	-35.54	-8.54	-27
2	6.00	5250~5350	5350.8	-30.57	-3.57	-27
2	6.00	5725~5825	5724.8	-18.73	-1.73	-27
2	6.00	5725~5825	5715.0	-29.14	-2.14	-17
2	6.00	5725~5825	5826.2	-20.26	-3.26	-17
2	6.00	5725~5825	5837.6	-29.10	-2.10	-27
3	8.00	5150~5250	5147.6	-29.32	-2.32	-27
3	8.00	5250~5350	5350.6	-27.70	-0.70	-27
3	8.00	5725~5825	5724.0	-17.10	-0.10	-27
3	8.00	5725~5825	5715.0	-27.24	-0.24	-17
3	8.00	5725~5825	5825.2	-18.14	-1.14	-17
3	8.00	5725~5825	5836.6	-27.03	-0.03	-27
4	2.50	5150~5250	5147.4	-32.67	-15.67	-27
4	2.50	5250~5350	5350.2	-27.58	-10.58	-27
4	2.50	5725~5825	5724.2	-17.22	-0.22	-27
4	2.50	5725~5825	5714.0	-27.29	-10.29	-17
4	2.50	5725~5825	5825.2	-28.13	-11.13	-17
4	2.50	5725~5825	5836.6	-17.58	-0.58	-27



Normal Mode (Mode 1)

Channel: 01 / 5180 MHz

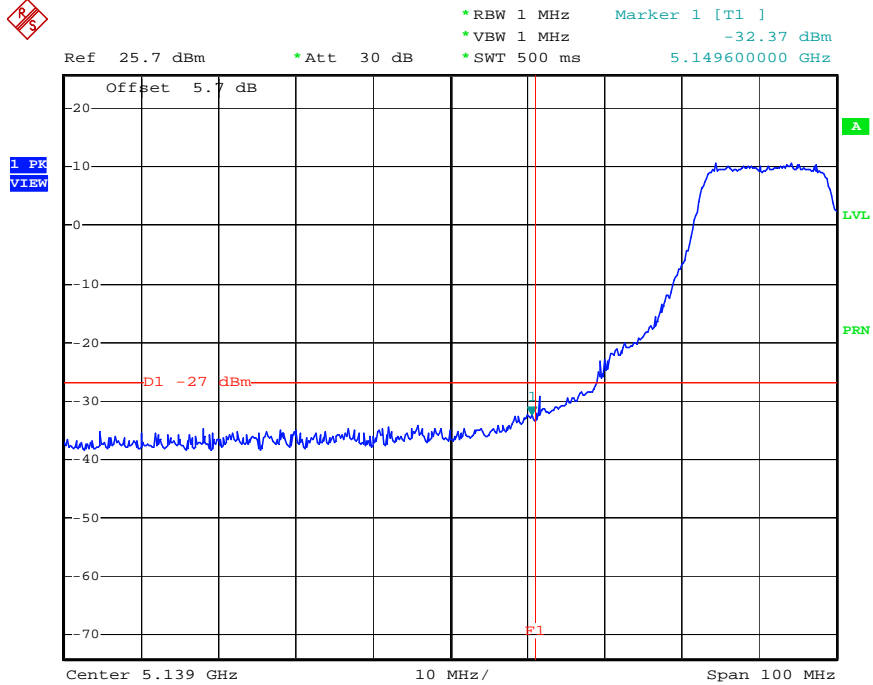

Date: 4.NOV.2004 17:30:33

Channel: 08 / 5320 MHz

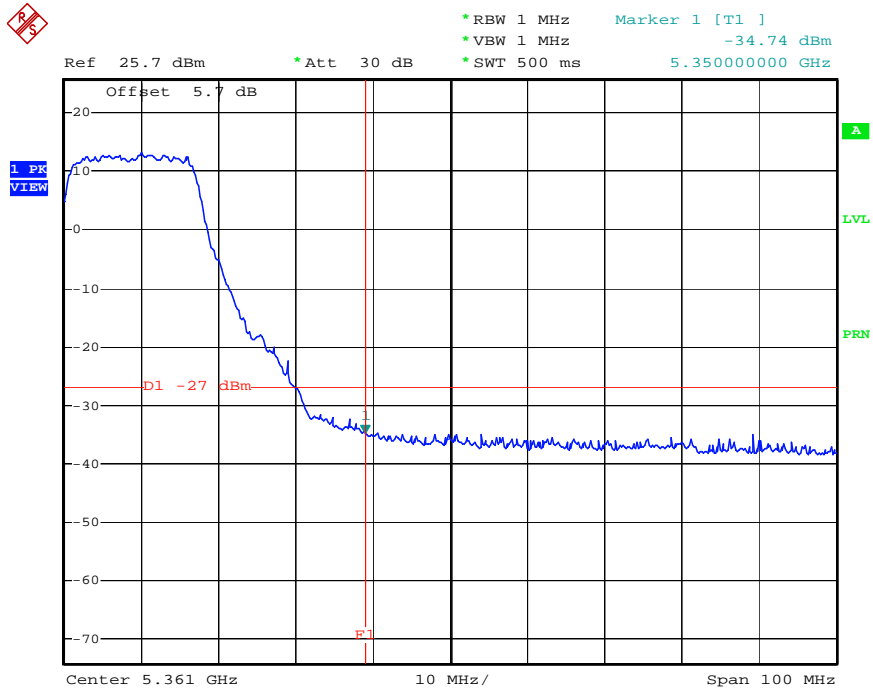

Date: 4.NOV.2004 17:39:04



Channel: 09 / 5745 MHz

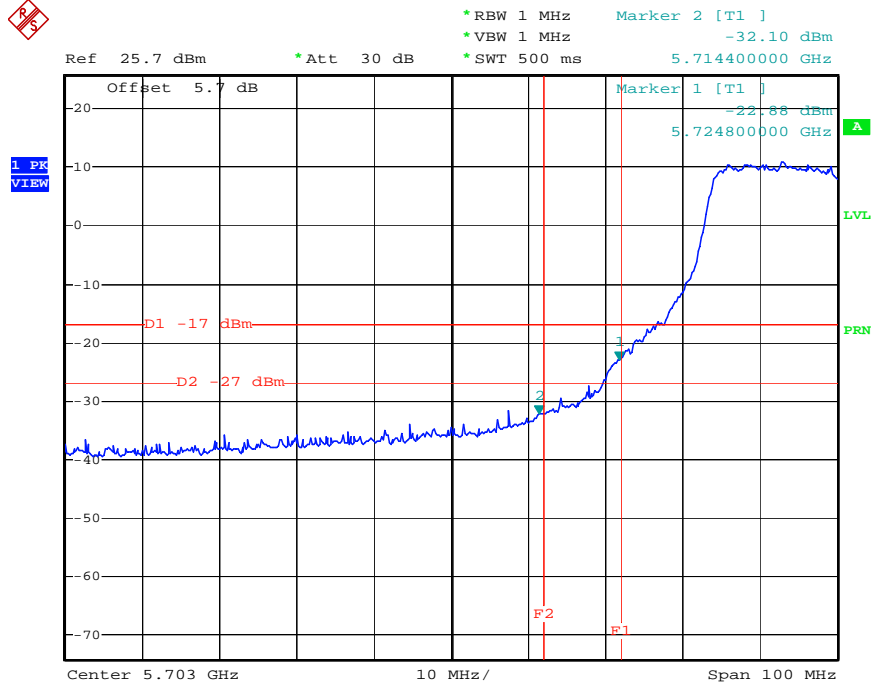

Date: 4.NOV.2004 17:43:32

Channel: 12 / 5805 MHz

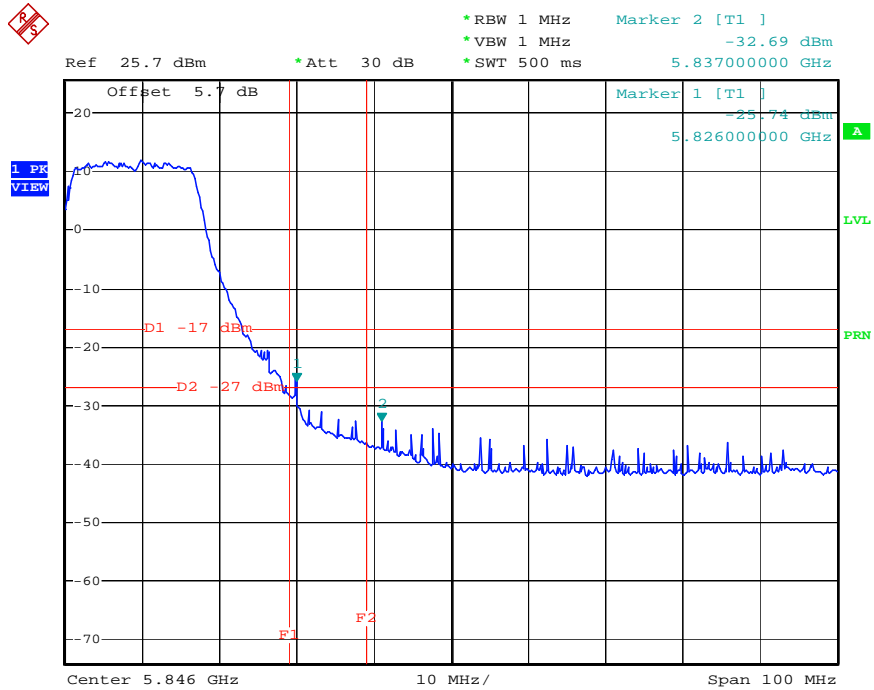

Date: 4.NOV.2004 17:52:32



Turbo Mode (Mode 1)

Channel: 01 / 5210 MHz

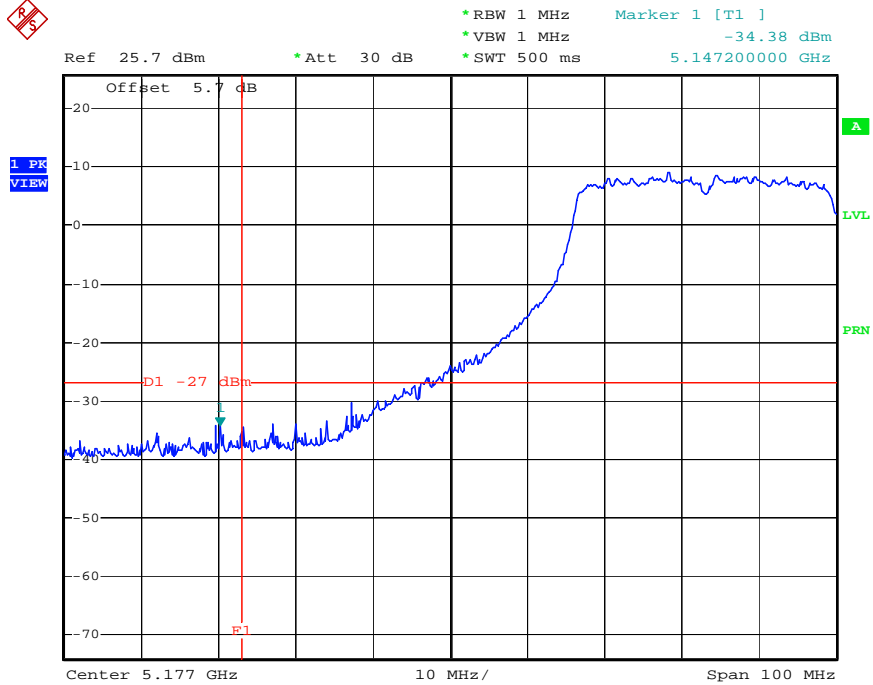

Date: 8.NOV.2004 11:15:22

Channel: 03 / 5290 MHz

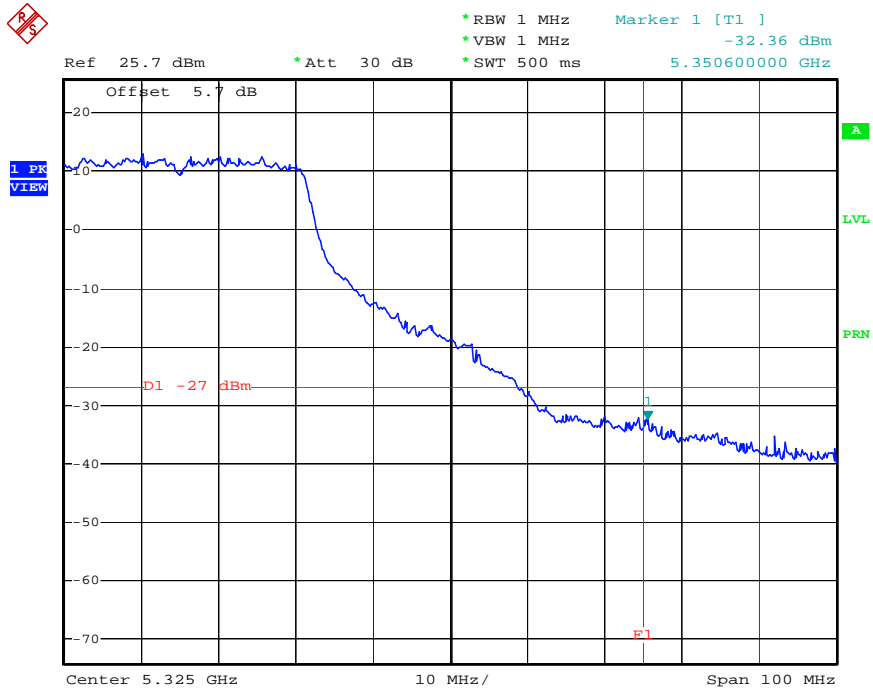

Date: 8.NOV.2004 11:39:24



Channel: 04 / 5760 MHz

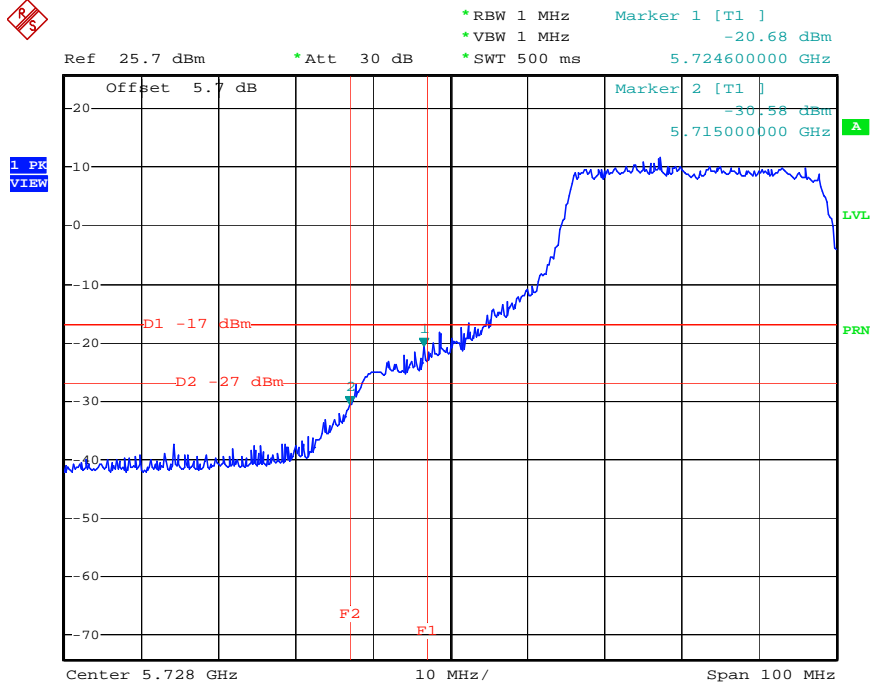

Date: 4.NOV.2004 18:26:03

Channel: 05 / 5800 MHz

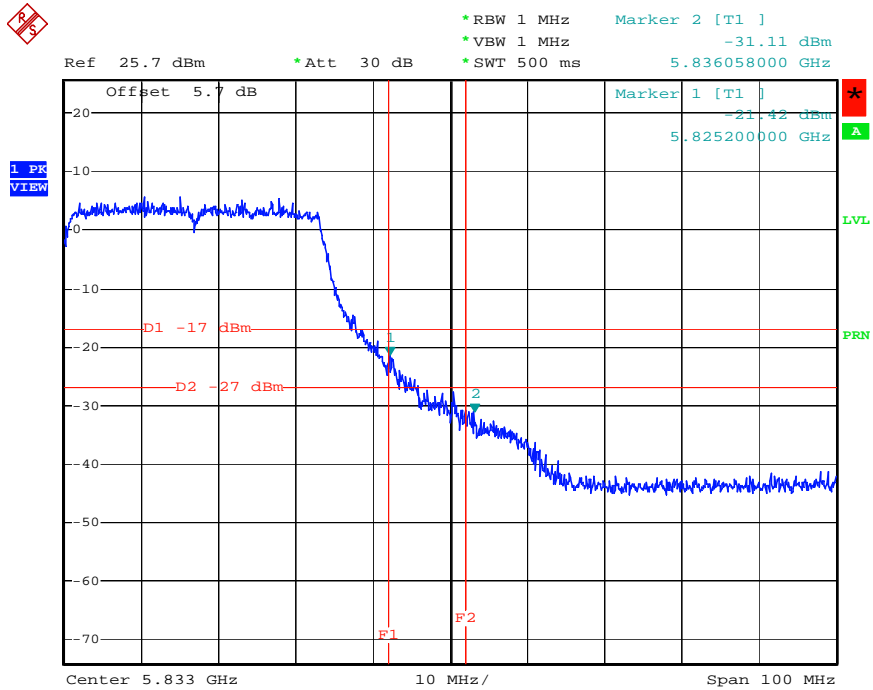

Date: 4.NOV.2004 19:11:07



Normal Mode (Mode 2)

Channel: 01 / 5180 MHz

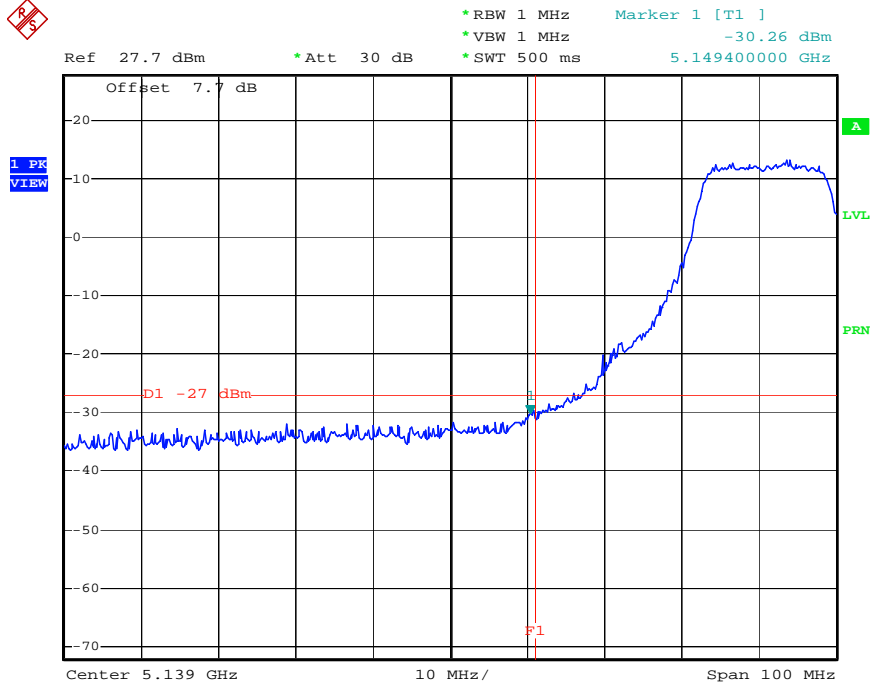

Date: 4.NOV.2004 17:31:27

Channel: 08 / 5320 MHz

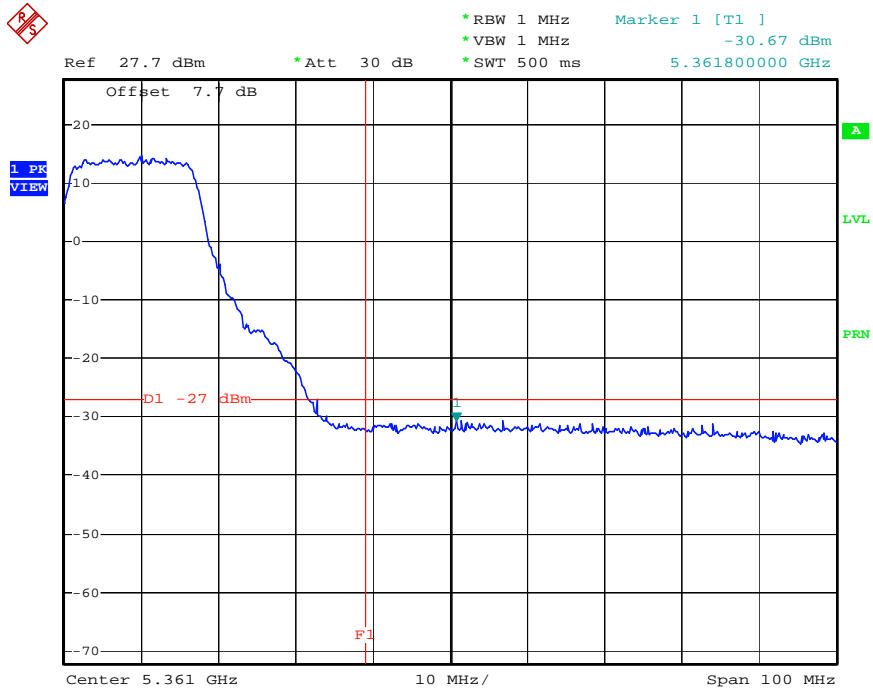

Date: 4.NOV.2004 17:37:55



Channel: 09 / 5745 MHz

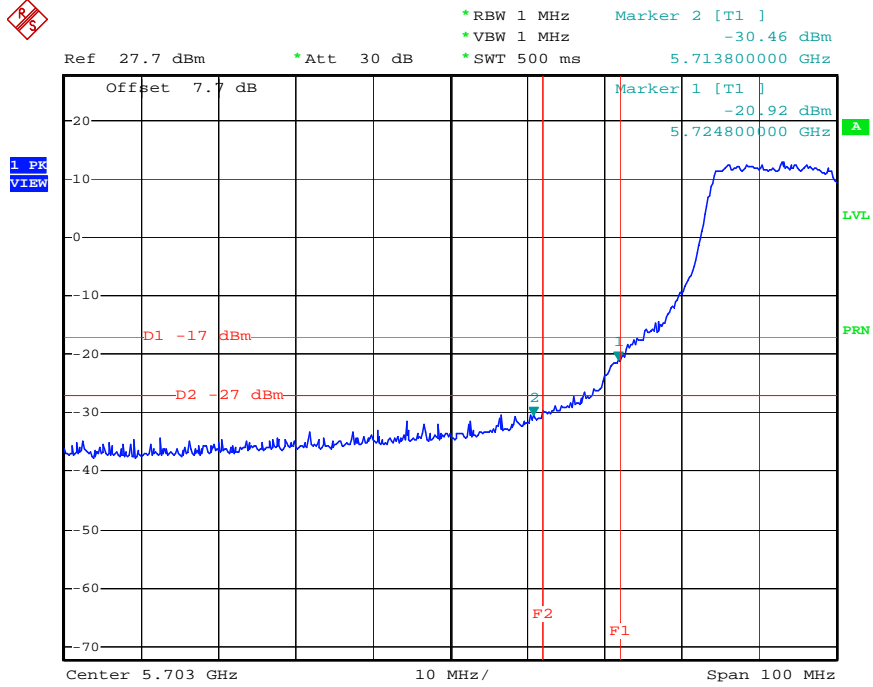

Date: 4.NOV.2004 17:44:50

Channel: 12 / 5805 MHz

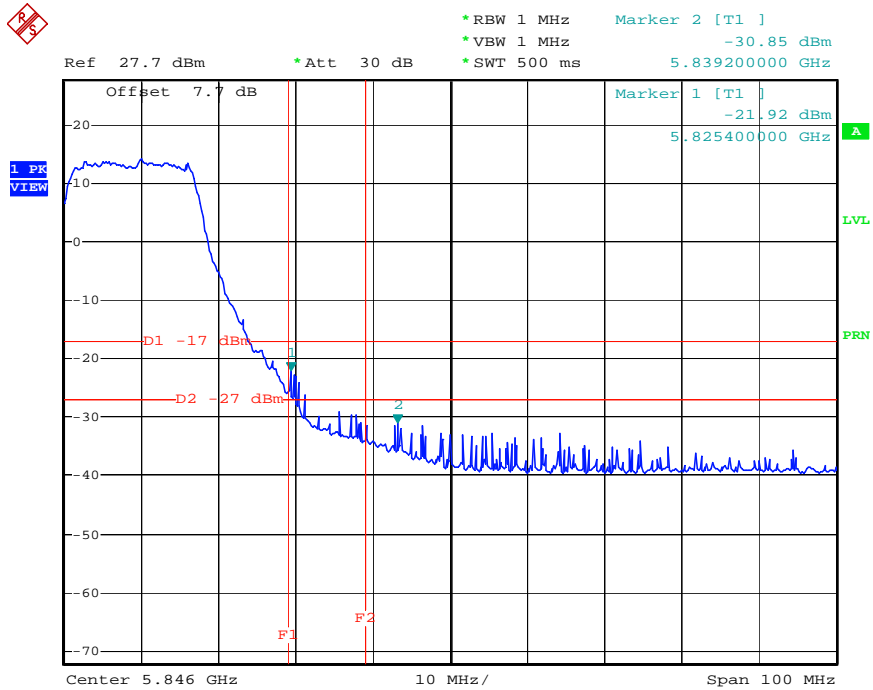

Date: 4.NOV.2004 17:51:16



Turbo Mode (Mode 2)

Channel: 01 / 5210 MHz

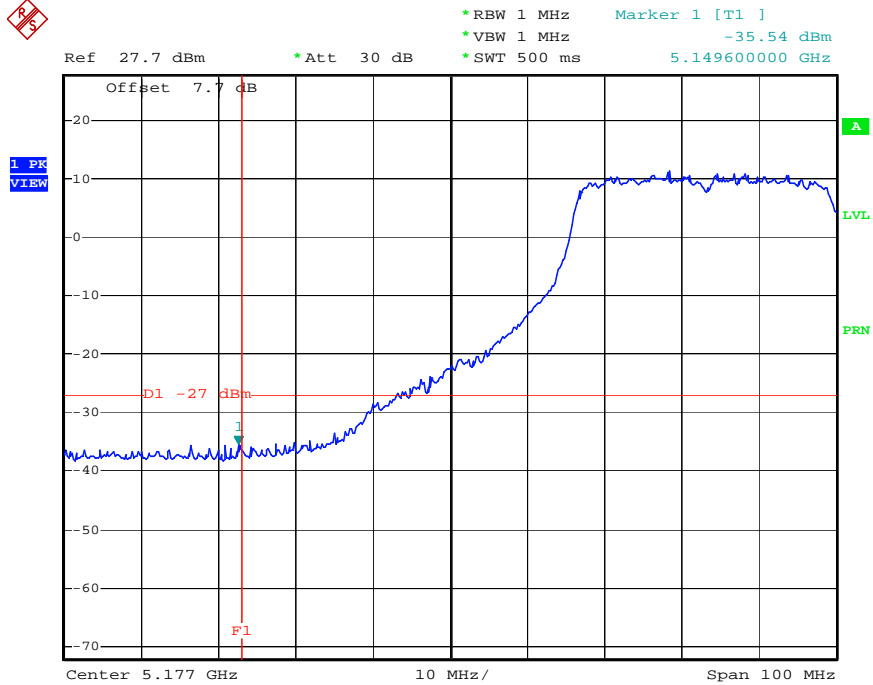

Date: 8.NOV.2004 11:16:33

Channel: 03 / 5290 MHz

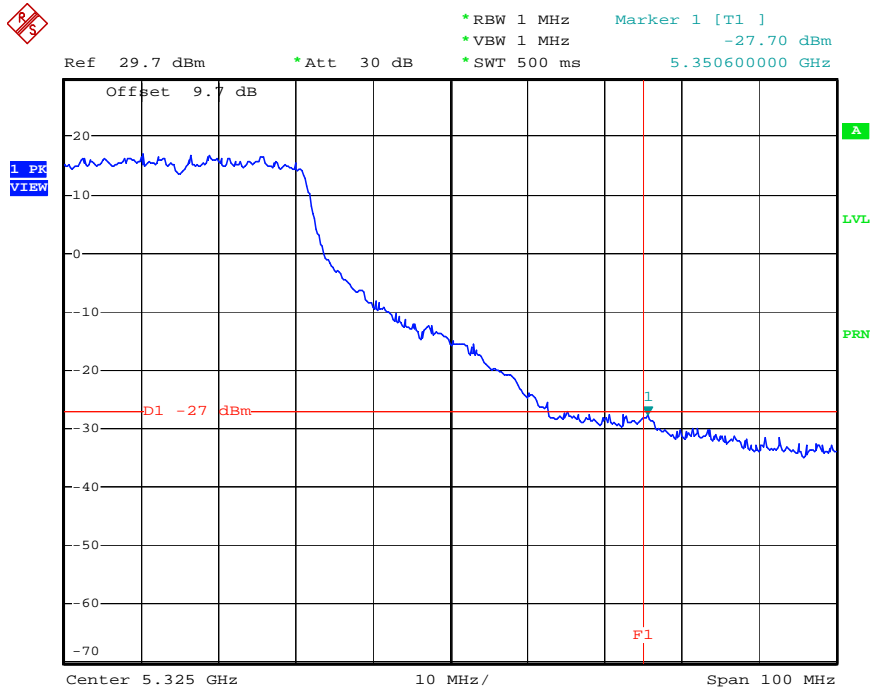

Date: 8.NOV.2004 11:36:28



Channel: 04 / 5760 MHz

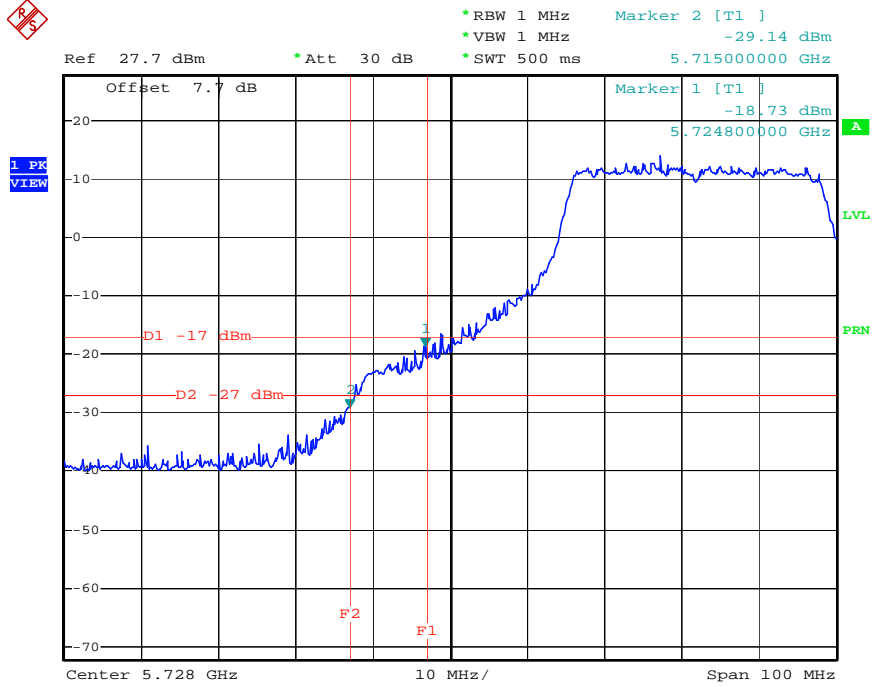

Date: 4.NOV.2004 18:26:56

Channel: 05 / 5800 MHz

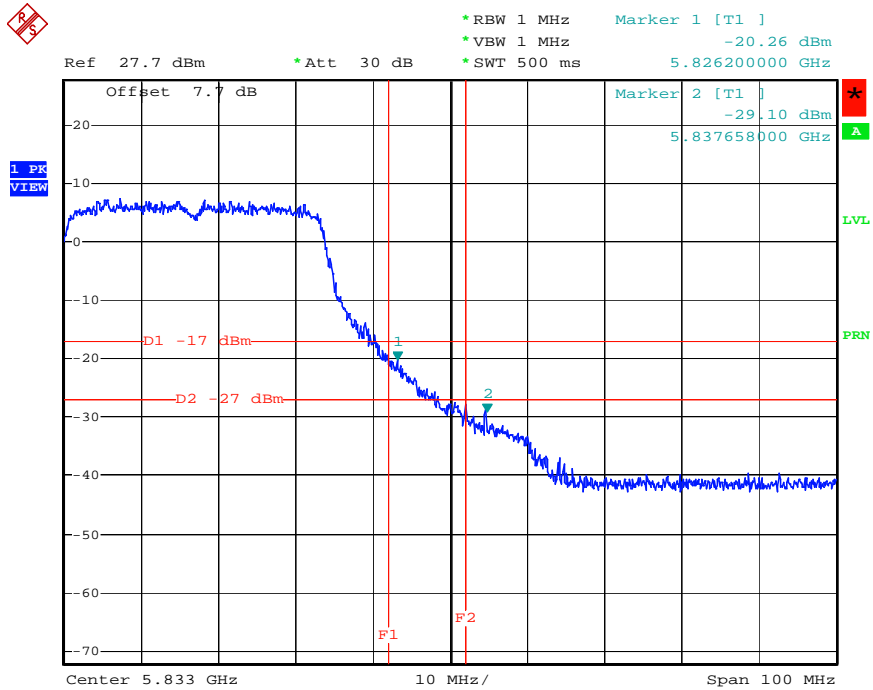

Date: 4.NOV.2004 19:16:56



Normal Mode (Mode 3)

Channel: 01 / 5180 MHz

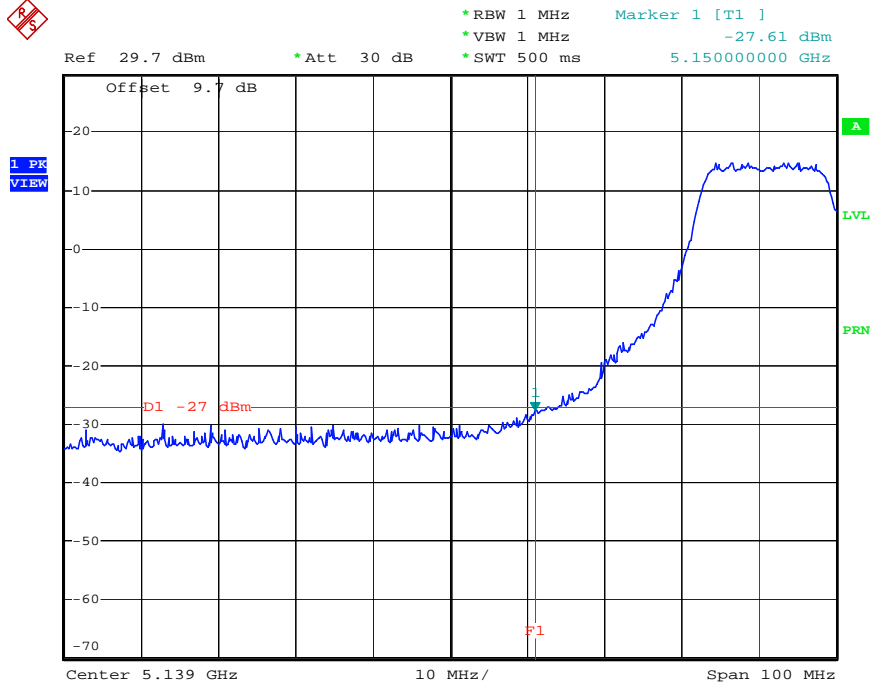

Date: 4.NOV.2004 17:28:41

Channel: 08 / 5320 MHz

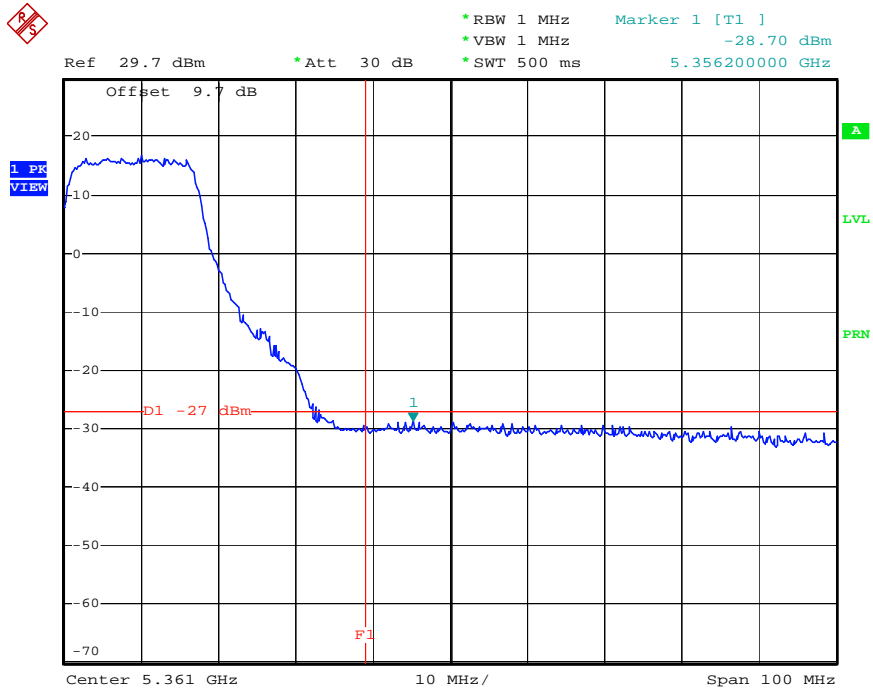

Date: 4.NOV.2004 17:36:42



Channel: 09 / 5745 MHz

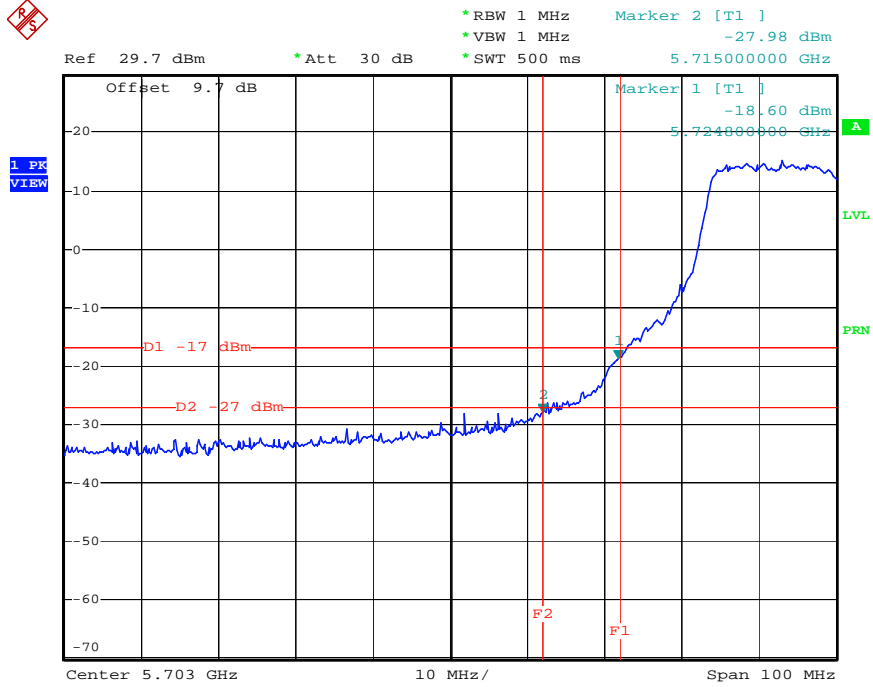

Date: 4.NOV.2004 17:42:25

Channel: 12 / 5805 MHz

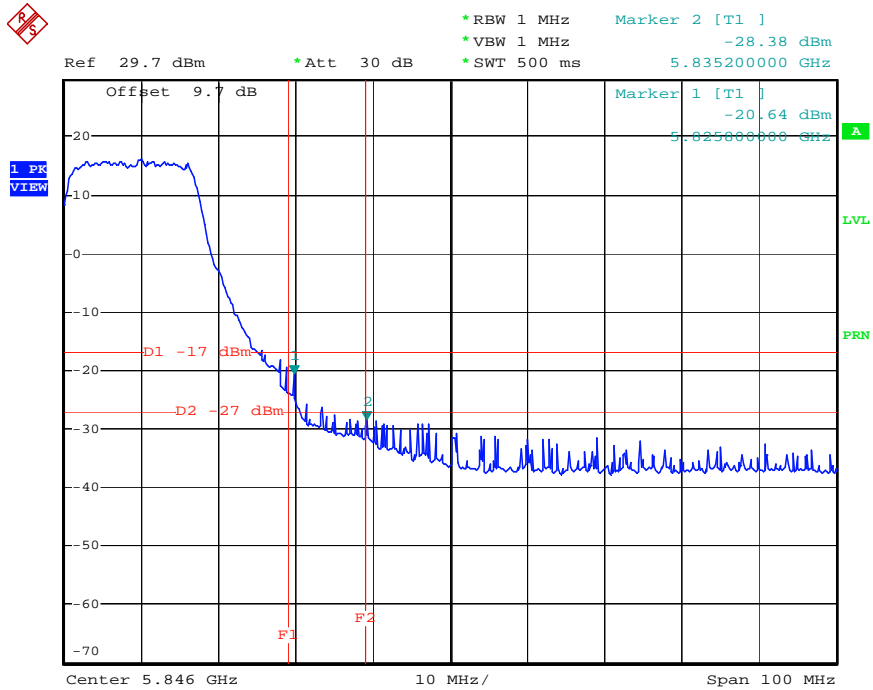

Date: 4.NOV.2004 17:49:35



Turbo Mode (Mode 3)

Channel: 01 / 5210 MHz

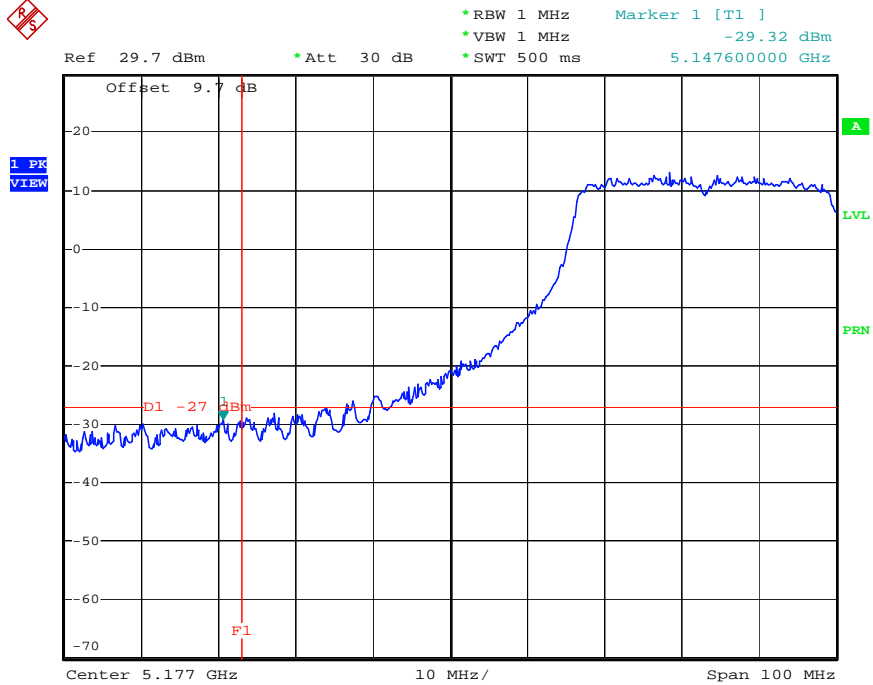

Date: 8.NOV.2004 11:14:29

Channel: 03 / 5290 MHz

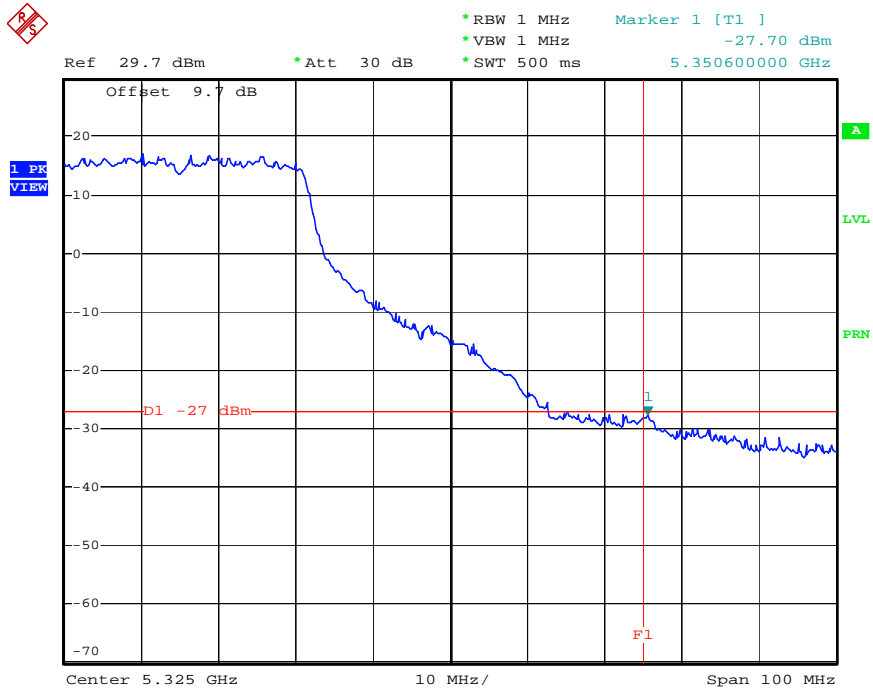

Date: 8.NOV.2004 11:36:28



Channel: 04 / 5760 MHz

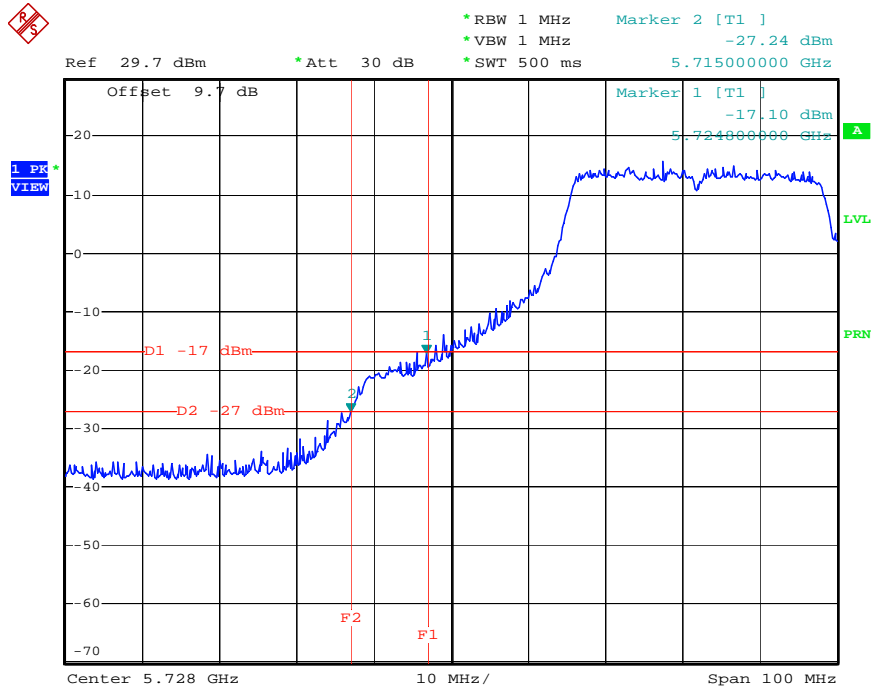

Date: 4.NOV.2004 18:24:37

Channel: 05 / 5800 MHz

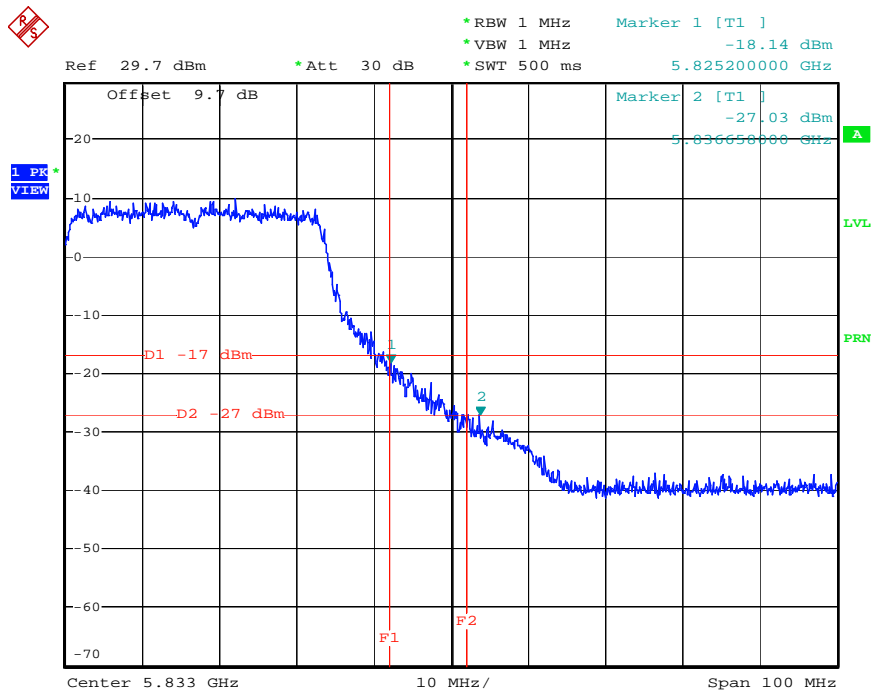

Date: 4.NOV.2004 19:09:41