



FCC TEST REPORT (15.407)

REPORT NO.: RF940413L11
MODEL NO.: SL-3055
(refer to page 7 for other models)
RECEIVED: Apr. 15, 2005
TESTED: Apr. 15 ~ May 05, 2005
ISSUED: May 09, 2005

APPLICANT: 3Com Corporation

ADDRESS: 350 Campus Drive, Marlborough, MA
10752-3064. U.S.A.

ISSUED BY: Advance Data Technology Corporation

LAB ADDRESS: No. 47, 14th Ling, Chia Pau Tsuen, Lin Kou
Hsiang 244, Taipei Hsien, Taiwan, R.O.C.

TEST LOCATION: No. 19, Hwa Ya 2nd Rd., Wen Hwa Tsuen,
Kwei Shan Hsiang, Taoyuan Hsien 333,
Taiwan, R.O.C.

This test report consists of 89 pages in total. It may be duplicated completely for legal use with the approval of the applicant. It should not be reproduced except in full, without the written approval of our laboratory. The client should not use it to claim product endorsement by CNLA, A2LA or any government agencies. The test results in the report only apply to the tested sample.



0528
ILAC MRA



No. 2177-01



Table of Contents

1.	CERTIFICATION	4
2.	SUMMARY OF TEST RESULTS	5
2.1	MEASUREMENT UNCERTAINTY	6
3.	GENERAL INFORMATION.....	7
3.1	GENERAL DESCRIPTION OF EUT	7
3.2	DESCRIPTION OF TEST MODES.....	9
3.2.1	CONFIGURATION OF SYSTEM UNDER TEST	10
3.2.2	TEST MODE APPLICABILITY AND TESTED CHANNEL DETAIL:.....	11
3.3	GENERAL DESCRIPTION OF APPLIED STANDARDS	13
3.4	DESCRIPTION OF SUPPORT UNITS	14
4.	TEST TYPES AND RESULTS (5150 ~ 5350MHz BAND)	15
4.1	CONDUCTED EMISSION MEASUREMENT	15
4.1.1	LIMITS OF CONDUCTED EMISSION MEASUREMENT.....	15
4.1.2	TEST INSTRUMENTS.....	15
4.1.3	TEST PROCEDURES	16
4.1.4	DEVIATION FROM TEST STANDARD	16
4.1.5	TEST SETUP	17
4.1.6	EUT OPERATING CONDITIONS	17
4.1.7	TEST RESULTS	18
4.2	RADIATED EMISSION MEASUREMENT	20
4.2.1	LIMITS OF RADIATED EMISSION MEASUREMENT.....	20
4.2.2	LIMITS OF UNWANTED EMISSION OUT OF THE RESTRICTED BANDS.....	21
4.2.3	TEST INSTRUMENTS.....	22
4.2.4	TEST PROCEDURES	23
4.2.5	DEVIATION FROM TEST STANDARD	23
4.2.6	TEST SETUP	24
4.2.7	EUT OPERATING CONDITION	24
4.2.8	TEST RESULTS	25
4.3	PEAK TRANSMIT POWER MEASUREMENT	42
4.3.1	LIMITS OF PEAK TRANSMIT POWER MEASUREMENT.....	42
4.3.2	TEST INSTRUMENTS.....	42
4.3.3	TEST PROCEDURE.....	43
4.3.4	DEVIATION FROM TEST STANDARD	43
4.3.5	TEST SETUP	43
4.3.6	EUT OPERATING CONDITIONS	43
4.3.7	TEST RESULTS	44
4.4	PEAK POWER EXCURSION MEASUREMENT	54
4.4.1	LIMITS OF PEAK POWER EXCURSION MEASUREMENT.....	54



4.4.2	TEST INSTRUMENTS.....	54
4.4.3	TEST PROCEDURE.....	55
4.4.4	DEVIATION FROM TEST STANDARD	55
4.4.5	TEST SETUP	55
4.4.6	EUT OPERATING CONDITIONS	55
4.4.7	TEST RESULTS	56
4.5	PEAK POWER SPECTRAL DENSITY MEASUREMENT	62
4.5.1	LIMITS OF PEAK POWER SPECTRAL DENSITY MEASUREMENT.....	62
4.5.2	TEST INSTRUMENTS.....	62
4.5.3	TEST PROCEDURES	63
4.5.4	DEVIATION FROM TEST STANDARD	63
4.5.5	TEST SETUP	63
4.5.6	EUT OPERATING CONDITIONS	63
4.5.7	TEST RESULTS	64
4.6	FREQUENCY STABILITY	70
4.6.1	LIMITS OF FREQUENCY STABILITY MEASUREMENT	70
4.6.2	TEST INSTRUMENTS.....	70
4.6.3	TEST PROCEDURE.....	70
4.6.4	DEVIATION FROM TEST STANDARD	70
4.6.5	TEST SETUP	71
4.6.6	EUT OPERATING CONDITION	71
4.6.7	TEST RESULTS	72
4.7	BAND EDGES MEASUREMENT	73
4.7.1	TEST INSTRUMENTS.....	73
4.7.2	TEST PROCEDURE.....	73
4.7.3	EUT OPERATING CONDITION	73
4.7.4	TEST RESULTS	73
4.8	ANTENNA REQUIREMENT	84
4.8.1	STANDARD APPLICABLE	84
4.8.2	ANTENNA CONNECTED CONSTRUCTION	84
5.	PHOTOGRAPHS OF THE TEST CONFIGURATION.....	85
6.	INFORMATION ON THE TESTING LABORATORIES	89



1. CERTIFICATION

PRODUCT: 11a/b/g Wireless PCI Adapter
BRAND NAME: 3Com (refer to page 7 for other brands)
MODEL NO.: SL-3055
(refer to page 7 for other models)
APPLICANT: 3Com Corporation
TEST SAMPLE: ENGINEERING SAMPLE
TESTED: Apr. 15 ~ May 05, 2005
STANDARDS: FCC Part 15, Subpart E (Section 15.407)
ANSI C63.4-2003

The above equipment has been tested by **Advance Data Technology Corporation**, and found compliance with the requirement of the above standards. The test record, data evaluation & Equipment Under Test (EUT) configurations represented herein are true and accurate accounts of the measurements of the sample's EMC characteristics under the conditions specified in this report.

PREPARED BY : Candice Chen, **DATE:** May 09, 2005
(Candice Chen)

TECHNICAL
ACCEPTANCE : Gary Chang, **DATE:** May 09, 2005
Responsible for RF (Gary Chang)

APPROVED BY : Gary Chang for, **DATE:** May 09, 2005
(Cody Chang, Deputy Manager)



2. SUMMARY OF TEST RESULTS

The EUT has been tested according to the following specifications:

APPLIED STANDARD: FCC Part 15, Subpart E (Section 15.407)			
Standard Section	Test Type	Result	Remark
15.407(b)(5)	AC Power Conducted Emission	PASS	Meet the requirement of limit. Minimum passing margin is -17.67dB at 0.955MHz
15.407(b/1/2/3) (b)(5)	Electric Field Strength Spurious Emissions, 30MHz ~ 40000MHz	PASS	Meet the requirement of limit. Minimum passing margin is -1.26dB at 5350.00MHz
15.407(a/1/2/3)	Peak Transmit Power	PASS	Meet the requirement of limit.
15.407(a)(6)	Peak Power Excursion	PASS	Meet the requirement of limit.
15.407(a/1/2/3)	Peak Power Spectral Density	PASS	Meet the requirement of limit.
15.407(g)	Frequency Stability	PASS	Meet the requirement of limit.

2.1 MEASUREMENT UNCERTAINTY

Where relevant, the following measurement uncertainty levels have been estimated for tests performed on the EUT as specified in CISPR 16-4:

Measurement	Frequency	Uncertainty
Conducted emissions	9kHz~30MHz	2.44 dB
	30MHz ~ 200MHz	3.73 dB
Radiated emissions	200MHz ~1000MHz	3.74 dB
	1GHz ~ 18GHz	2.20 dB
	18GHz ~ 40GHz	1.88 dB



3. GENERAL INFORMATION

3.1 GENERAL DESCRIPTION OF EUT

EUT	11a/b/g Wireless PCI Adapter
MODEL NO.	SL-3055
POWER SUPPLY	3.3Vdc from host equipment
MODULATION TYPE	CCK, DQPSK, DBPSK for DSSS 64QAM, 16QAM, QPSK, BPSK for OFDM
MODULATION TECHNOLOGY	DSSS, OFDM
TRANSFER RATE	802.11b: 11/5.5/2/1Mbps 802.11g: 54/48/36/24/18/12/9/6Mbps (Turbo mode: up to 108Mbps *see Note 4) 802.11a: 54/48/36/24/18/12/9/6Mbps (Turbo mode: up to 108Mbps *see Note 4)
FREQUENCY RANGE	802.11b & 802.11g: 2.412 ~ 2.462GHz 802.11a: 5.150 ~ 5.350GHz and 5.725 ~ 5.850GHz
NUMBER OF CHANNEL	802.11b & 802.11g: 11 for Normal mode / 1 for Turbo mode 802.11a: 12 for Normal mode / 5 for Turbo mode
CHANNEL SPACING	802.11b & 802.11g: 5MHz 802.11a: 20MHz for Normal mode / 40MHz for Turbo mode
OUTPUT POWER	65.013mW for 802.11b 81.283mW for 802.11g 43.451mW for 5.150 ~ 5.350GHz 101.158mW for 5.725 ~ 5.850GHz
ANTENNA TYPE	Please refer to the note 3 as below
DATA CABLE	NA
I/O PORTS	PCI
ASSOCIATED DEVICES	NA

NOTE:

1. The EUT operates in both the 5GHz and 2.4GHz Bands and compatibility with 802.11a and 802.11b, 802.11g technology.
2. There are four brands, and model names provided to this EUT. Please refer to the table as below for EUT's information:

Brand	Model Name
3Com	SL-3055
3Com	3CRDAG675B
3Com	3CRDAG675B-AP
Gemtek	WPIA-112AG



3. The EUT have two combinations of antenna type. Please refer to following table.

No.	Brand	Antenna type	2.4GHz Gain (dBi)	5GHz Gain (dBi)
1	3COM	Dipole	1.17	2.02
2	WSS003 Dual Band	Dipole	1.50	2.50

4. This EUT is capable of providing data rates of up to 108 Mbps in Turbo mode depending upon reception quality.
5. The above EUT information was declared by the manufacturer and for more detailed features description, please refer to the manufacturer's specifications or User's Manual.



3.2 DESCRIPTION OF TEST MODES

Operated in 5150 ~ 5250MHz, 5250MHz ~ 5350MHz bands:

Eight channels are provided to this EUT for normal mode.

Channel	Frequency
1	5180 MHz
2	5200 MHz
3	5220 MHz
4	5240 MHz
5	5260 MHz
6	5280 MHz
7	5300 MHz
8	5320 MHz

Three channels are provided to this EUT for turbo mode.

Channel	Frequency
1	5210 MHz
2	5250 MHz
3	5290 MHz

3.2.1 CONFIGURATION OF SYSTEM UNDER TEST

Test Mode A:

(Power from host equipment)

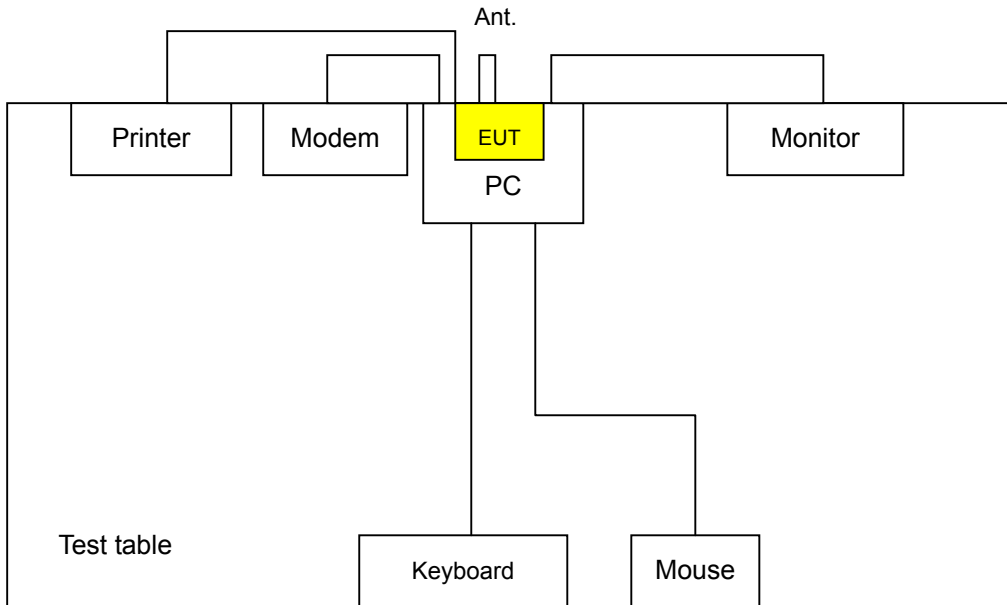

Test Mode B:

(Power from host equipment)

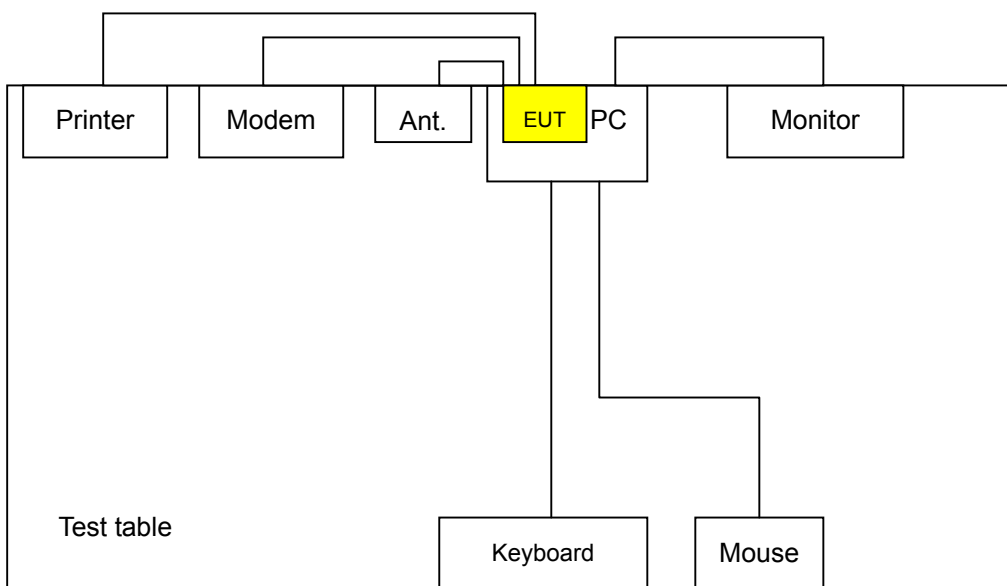



3.2.2 TEST MODE APPLICABILITY AND TESTED CHANNEL DETAIL:

EUT configure mode	Applicable to				Description
	PLC	RE<1G	RE≥1G	APCM	
A	Note 1	X	X	Note 2	antenna 1 (see note 1 of section 3.1)
B	Note 1	X	X	Note 2	antenna 2 (see note 1 of section 3.1)

Where PLC: Power Line Conducted Emission RE<1G RE: Radiated Emission below 1GHz
 RE≥1G: Radiated Emission above 1GHz APCM: Antenna Port Conducted Measurement
 Note 1: No effect on Conducted RF measurement.
 Note 2: Conducted RF measurement is independent of antenna.

Power Line Conducted Emission Test:

- Pre-Scan has been conducted to determine the worst-case mode from all possible combinations between available modulations, data rates and antenna ports (if EUT with antenna diversity architecture).
- Following channel(s) was (were) selected for the final test as listed below.

EUT configure mode	Mode	Available Channel	Tested Channel	Modulation Technology	Modulation Type	Data Rate (Mbps)
B	802.11a	1 to 8	5	OFDM	BPSK	6

Radiated Emission Test (Below 1 GHz):

- Pre-Scan has been conducted to determine the worst-case mode from all possible combinations between available modulations, data rates and antenna ports (if EUT with antenna diversity architecture).
- Following channel(s) was (were) selected for the final test as listed below.

EUT configure mode	Mode	Available Channel	Tested Channel	Modulation Technology	Modulation Type	Data Rate (Mbps)
A	802.11a	1 to 8	5	OFDM	BPSK	6
B	802.11a	1 to 8	5	OFDM	BPSK	6

Radiated Emission Test (Above 1 GHz):

- Pre-Scan has been conducted to determine the worst-case mode from all possible combinations between available modulations, data rates and antenna ports (if EUT with antenna diversity architecture).
- Following channel(s) was (were) selected for the final test as listed below.

EUT configure mode	Mode	Available Channel	Tested Channel	Modulation Technology	Modulation Type	Data Rate (Mbps)
A	802.11a	1 to 8	1, 4, 5, 8	OFDM	BPSK	6
B	802.11a	1 to 8	1, 4, 5, 8	OFDM	BPSK	6
A	802.11a Turbo	1 to 3	1, 2, 3	OFDM	BPSK	12
B	802.11a Turbo	1 to 3	1, 2, 3	OFDM	BPSK	12



Bandedge Measurement:

- Pre-Scan has been conducted to determine the worst-case mode from all possible combinations between available modulations, data rates and antenna ports (if EUT with antenna diversity architecture).
- Following channel(s) was (were) selected for the final test as listed below.

Mode	Available Channel	Tested Channel	Modulation Technology	Modulation Type	Data Rate (Mbps)
802.11a	1 to 8	1, 8	OFDM	BPSK	6
802.11a Turbo	1 to 3	1, 3	OFDM	BPSK	12

Antenna Port Conducted Measurement:

- Pre-Scan has been conducted to determine the worst-case mode from all possible combinations between available modulations, data rates and antenna ports (if EUT with antenna diversity architecture).
- Following channel(s) was (were) selected for the final test as listed below.

Mode	Available Channel	Tested Channel	Modulation Technology	Modulation Type	Data Rate (Mbps)
802.11a	1 to 8	1, 4, 5, 8	OFDM	BPSK	6
802.11a Turbo	1 to 3	1, 2, 3	OFDM	BPSK	12



3.3 GENERAL DESCRIPTION OF APPLIED STANDARDS

The EUT is a 11a/b/g Wireless PCI Adapter. According to the specifications of the manufacturer, it must comply with the requirements of the following standards:

FCC Part 15, Subpart E (15.407)

ANSI C63.4-2003

All test items have been performed and recorded as per the above standards.

NOTE: The EUT is also considered as a kind of computer peripheral, because the connection to computer is necessary for typical use. It has been verified to comply with the requirements of FCC Part 15, Subpart B, Class B (DoC). The test report has been issued separately.



3.4 DESCRIPTION OF SUPPORT UNITS

The EUT has been tested as an independent unit together with other necessary accessories or support units. The following support units or accessories were used to form a representative test configuration during the tests.

NO.	PRODUCT	BRAND	MODEL NO.	SERIAL NO.	FCC ID
1	PC	MSI	Hetis 865G	380125734	FCC DoC Approved
2	LCD MONITOR	ACER	AL1721	ET.L0408.01040 4001E6PK00	FCC DoC Approved
3	PRINTER	EPSON	LQ-300+	DCGY054147	FCC DoC Approved
4	MOUSE	HP	M-S69	M4-010565	INZ211443
5	KEYBOARD	HP	SK-1688	C0306114659	GYUR84SK
6	MODEM	ACEEX	1414V/3	0401008269	IFAXDM1414

NO.	SIGNAL CABLE DESCRIPTION OF THE ABOVE SUPPORT UNITS
1	NA
2	1.8 m shielded cable with one core
3	1.8 m shielded cable without core
4	1.2 m shielded cable without core
5	1.3 m shielded cable without core
6	1.2 m shielded cable without core

NOTE: All power cords of the above support units are non shielded (1.8m).



4. TEST TYPES AND RESULTS (5150 ~ 5350MHz Band)

4.1 CONDUCTED EMISSION MEASUREMENT

4.1.1 LIMITS OF CONDUCTED EMISSION MEASUREMENT

FREQUENCY OF EMISSION (MHz)	CONDUCTED LIMIT (dB μ V)	
	Quasi-peak	Average
0.15-0.5	66 to 56	56 to 46
0.5-5	56	46
5-30	60	50

- NOTE:**
1. The lower limit shall apply at the transition frequencies.
 2. The limit decreases in line with the logarithm of the frequency in the range of 0.15 to 0.50 MHz.
 3. All emanations from a class A/B digital device or system, including any network of conductors and apparatus connected thereto, shall not exceed the level of field strengths specified above.

4.1.2 TEST INSTRUMENTS

DESCRIPTION & MANUFACTURER	MODEL NO.	SERIAL NO.	CALIBRATED UNTIL
Test Receiver ROHDE & SCHWARZ	ESCS30	100291	Nov. 16, 2005
RF signal cable Woken	5D-FB	Cable-HYC01-01	Jan. 09, 2006
LISN ROHDE & SCHWARZ	ESH3-Z5	100312	Feb. 15, 2006
LISN ROHDE & SCHWARZ	ESH2-Z5	100104	Feb. 15, 2006
Software ADT	ADT_Cond_V3	NA	NA

- NOTE:**
1. The calibration interval of the above test instruments is 12 months and the calibrations are traceable to NML/ROC and NIST/USA.
 2. The test was performed in HwaYa Shielded Room 1.
 3. The VCCI Site Registration No. is C-2040.



4.1.3 TEST PROCEDURES

- a. The EUT was placed 0.4 meters from the conducting wall of the shielded room with EUT being connected to the power mains through a line impedance stabilization network (LISN). Other support units were connected to the power mains through another LISN. The two LISNs provide 50 ohm/ 50uH of coupling impedance for the measuring instrument.
- b. Both lines of the power mains connected to the EUT were checked for maximum conducted interference.
- c. The frequency range from 150kHz to 30MHz was searched. Emission levels under (Limit - 20dB) was not recorded.

4.1.4 DEVIATION FROM TEST STANDARD

No deviation

4.1.5 TEST SETUP

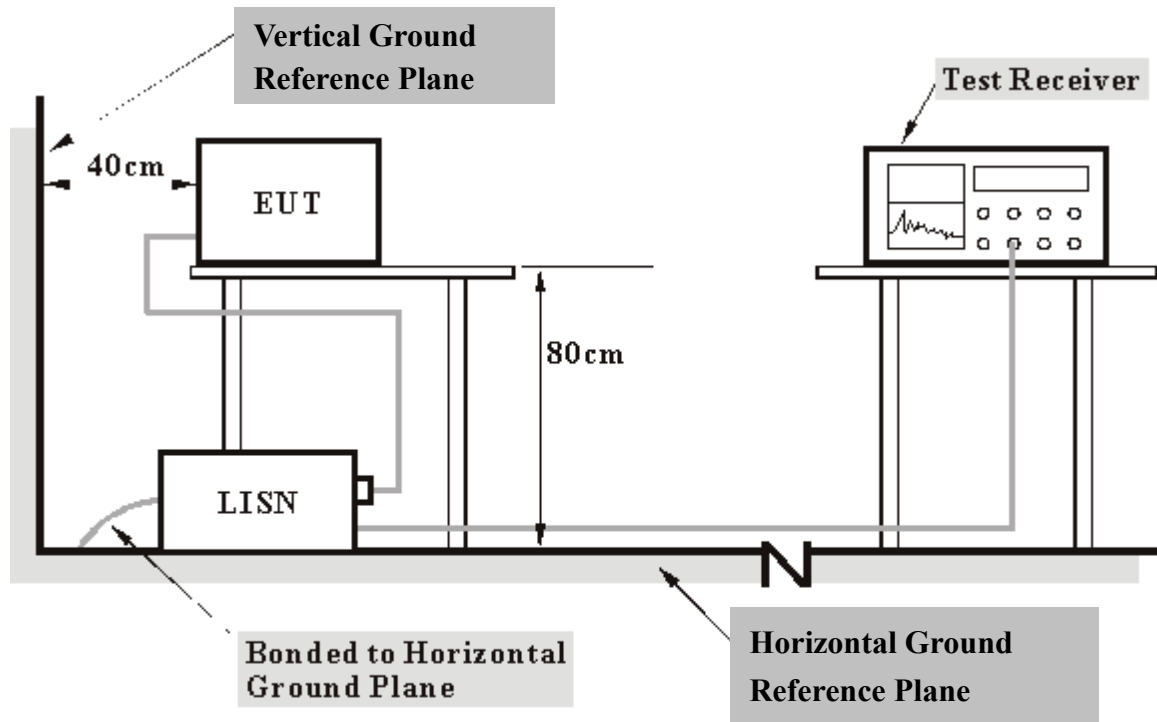

- Note:**
1. Support units were connected to second LISN.
 2. Both of LISNs (AMN) 80 cm from EUT and at the least 80 cm from other units and other metal planes support units.

For the actual test configuration, please refer to the related item – Photographs of the Test Configuration.

4.1.6 EUT OPERATING CONDITIONS

- a. Connected the EUT into Desktop PC placed on a testing table.
- b. The notebook system ran a test program (provided by manufacturer) to enable EUT under transmission/receiving condition continuously at specific channel frequency.
- c. The notebook system sent "H" messages to its screen.
- d. The notebook system sent "H" messages to modem.
- e. The notebook system sent "H" messages to printer, and the printer printed them on paper.
- f. Steps c ~ e were repeated.



4.1.7 TEST RESULTS

Conducted Worst-Case Data

EUT	11a/b/g Wireless PCI Adapter	MEASUREMENT DETAIL	
MODEL	SL-3055	PHASE	Line 1
CHANNEL	Channel 5	6dB BANDWIDTH	9 kHz
MODULATION TYPE	BPSK	ENVIRONMENTAL CONDITIONS	20deg. C, 60%RH, 991hPa
TRANSFER RATE	6Mbps	INPUT POWER (SYSTEM)	120Vac, 60 Hz
TESTED BY	Match Tsui		

No	Freq. [MHz]	Corr. Factor (dB)	Reading Value [dB (uV)]		Emission Level [dB (uV)]		Limit [dB (uV)]		Margin (dB)	
			Q.P.	AV.	Q.P.	AV.	Q.P.	AV.	Q.P.	AV.
			1	0.189	0.11	45.22	-	45.33	-	64.08
2	0.255	0.11	38.63	-	38.74	-	61.58	51.58	-22.84	-
3	0.447	0.12	36.60	-	36.72	-	56.93	46.93	-20.21	-
4	0.955	0.23	35.86	-	36.09	-	56.00	46.00	-19.91	-
5	3.055	0.33	34.17	-	34.50	-	56.00	46.00	-21.50	-
6	24.133	1.29	30.71	-	32.00	-	60.00	50.00	-28.00	-

- REMARKS:**
1. Q.P. and AV. are abbreviations of quasi-peak and average individually.
 2. "-": The Quasi-peak reading value also meets average limit and measurement with the average detector is unnecessary.
 3. The emission levels of other frequencies were very low against the limit.
 4. Margin value = Emission level - Limit value
 5. Correction factor = Insertion loss + Cable loss
 6. Emission Level = Correction Factor + Reading Value.

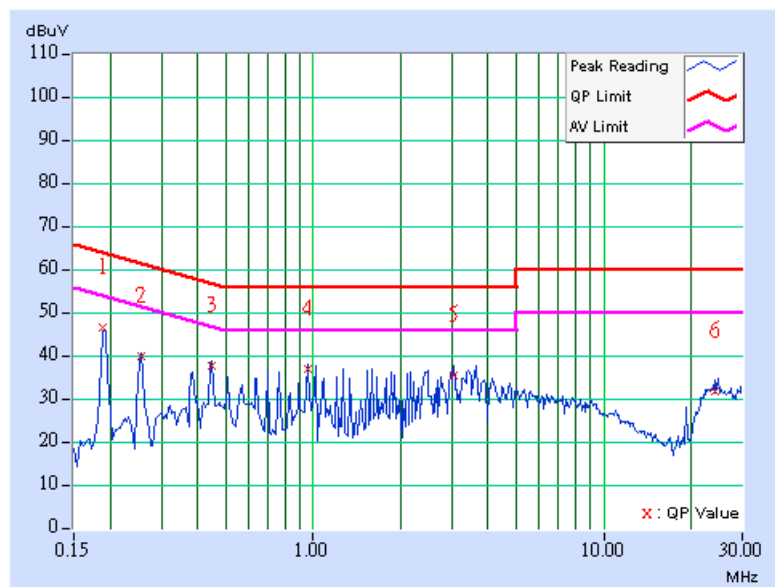



EUT	11a/b/g Wireless PCI Adapter	MEASUREMENT DETAIL	
MODEL	SL-3055	PHASE	Line 2
CHANNEL	Channel 5	6dB BANDWIDTH	9 kHz
MODULATION TYPE	BPSK	ENVIRONMENTAL CONDITIONS	20deg. C, 60%RH, 991hPa
TRANSFER RATE	6Mbps	INPUT POWER (SYSTEM)	120Vac, 60 Hz
TESTED BY	Match Tsui		

No	Freq. [MHz]	Corr. Factor (dB)	Reading Value		Emission Level		Limit		Margin	
			[dB (uV)]		[dB (uV)]		[dB (uV)]		(dB)	
			Q.P.	AV.	Q.P.	AV.	Q.P.	AV.	Q.P.	AV.
1	0.193	0.11	42.33	-	42.44	-	63.91	53.91	-21.47	-
2	0.380	0.11	39.11	-	39.22	-	58.27	48.27	-19.05	-
3	0.634	0.16	37.51	-	37.67	-	56.00	46.00	-18.33	-
4	0.955	0.23	38.10	-	38.33	-	56.00	46.00	-17.67	-
5	3.563	0.36	33.89	-	34.25	-	56.00	46.00	-21.75	-
6	22.862	0.80	25.98	-	26.78	-	60.00	50.00	-33.22	-

- REMARKS:**
1. Q.P. and AV. are abbreviations of quasi-peak and average individually.
 2. "-": The Quasi-peak reading value also meets average limit and measurement with the average detector is unnecessary.
 3. The emission levels of other frequencies were very low against the limit.
 4. Margin value = Emission level - Limit value
 5. Correction factor = Insertion loss + Cable loss
 6. Emission Level = Correction Factor + Reading Value.

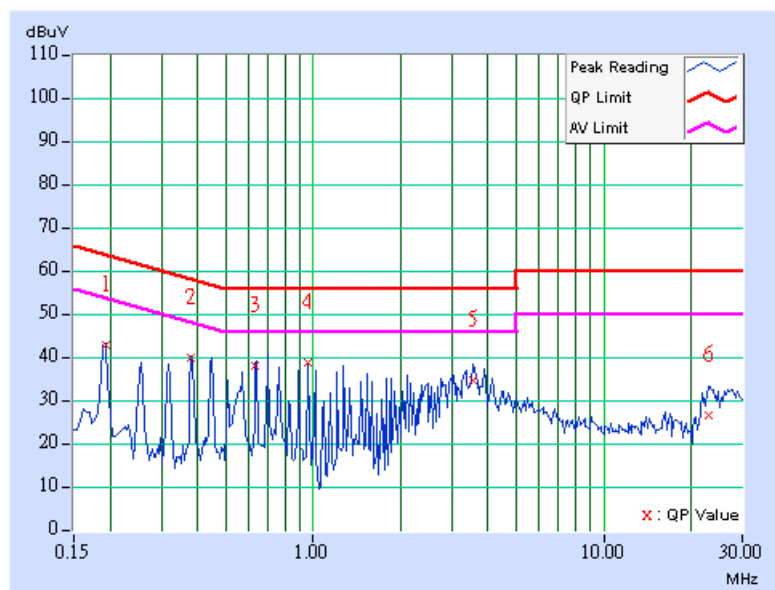



4.2 RADIATED EMISSION MEASUREMENT

4.2.1 LIMITS OF RADIATED EMISSION MEASUREMENT

Emissions radiated outside of the specified bands, shall be according to the general radiated limits in 15.209 as following:

Frequencies (MHz)	Field strength (microvolts/meter)	Measurement distance (meters)
0.009-0.490	2400/F(kHz)	300
0.490-1.705	24000/F(kHz)	30
1.705-30.0	30	30
30-88	100	3
88-216	150	3
216-960	200	3
Above 960	500	3

NOTE:

1. The lower limit shall apply at the transition frequencies.
2. Emission level (dBuV/m) = 20 log Emission level (uV/m).
3. As shown in 15.35(b), for frequencies above 1000MHz, the field strength limits are based on average detector, however, the peak field strength of any emission shall not exceed the maximum permitted average limits, specified above by more than 20dB under any condition of modulation.



4.2.2 LIMITS OF UNWANTED EMISSION OUT OF THE RESTRICTED BANDS

Frequencies (MHz)	EIRP Limit (dBm)	Equivalent Field Strength at 3m (dB μ V/m) *note 3
5150~5250	-27	68.3
5250~5350	-27	68.3
5725~5825	-27 *note 1	68.3
	-17 *note 2	78.3

NOTE:

1. For frequencies 10MHz or greater above or below the band edge.
2. All emissions within the frequency range from the band edge to 10MHz above or below the band edge.
3. The following formula is used to convert the equipment isotropic radiated power (eirp) to field strength

$$E = \frac{1000000\sqrt{30P}}{3} \quad \mu\text{V/m, where P is the eirp (Watts)}$$



4.2.3 TEST INSTRUMENTS

DESCRIPTION & MANUFACTURER	MODEL NO.	SERIAL NO.	CALIBRATED UNTIL
Test Receiver ROHDE & SCHWARZ	ESIB7	100188	Dec. 19, 2005
Spectrum Analyzer ROHDE & SCHWARZ	FSP40	100039	Nov. 21, 2005
BILOG Antenna SCHWARZBECK	VULB9168	9168-157	Jan. 22, 2006
HORN Antenna SCHWARZBECK	BBHA 9120 D	9120D-407	Jan. 16, 2006
HORN Antenna SCHWARZBECK	BBHA 9170	BBHA 9170241	Feb. 23, 2006
Preamplifier Agilent	8449B	3008A01961	Nov. 09, 2005
Preamplifier Agilent	8447D	2944A10629	Nov. 09, 2005
RF signal cable HUBER+SUHNER	SUCOFLEX 104	218182/4	Feb. 17, 2006
RF signal cable HUBER+SUHNER	SUCOFLEX 104	218194/4	Feb. 17, 2006
Software ADT.	ADT_Radiated_V5.14	NA	NA
Antenna Tower ADT.	AT100	AT93021702	NA
Turn Table ADT.	TT100.	TT93021702	NA
Controller ADT.	SC100.	SC93021702	NA

- NOTE:**
1. The calibration interval of the above test instruments is 12 months and the calibrations are traceable to NML/ROC and NIST/USA.
 2. The test was performed in HwaYa Chamber 1.
 3. The horn antenna and HP preamplifier (model: 8449B) are used only for the measurement of emission frequency above 1GHz if tested.
 4. The IC Site Registration No. is IC4924-2.



4.2.4 TEST PROCEDURES

- a. The EUT was placed on the top of a rotating table 0.8 meters above the ground at a 3 meter semi-anechoic chamber. The table was rotated 360 degrees to determine the position of the highest radiation.
- b. The EUT was set 3 meters away from the interference-receiving antenna, which was mounted on the top of a variable-height antenna tower.
- c. The antenna is a broadband antenna, and its height is varied from one meter to four meters above the ground to determine the maximum value of the field strength. Both horizontal and vertical polarizations of the antenna are set to make the measurement.
- d. For each suspected emission, the EUT was arranged to its worst case and then the antenna was tuned to heights from 1 meter to 4 meters and the rotatable table was turned from 0 degrees to 360 degrees to find the maximum reading.
- e. The test-receiver system was set to Peak Detect Function and Specified Bandwidth with Maximum Hold Mode.
- f. If the emission level of the EUT in peak mode was 10dB lower than the limit specified, then testing could be stopped and the peak values of the EUT would be reported. Otherwise the emissions that did not have 10dB margin would be re-tested one by one using peak, quasi-peak or average method as specified and then reported in a data sheet.

NOTE:

1. The resolution bandwidth and video bandwidth of test receiver/spectrum analyzer is 120kHz for Peak detection (PK) and Quasi-peak detection (QP) at frequency below 1GHz.
2. The resolution bandwidth and video bandwidth of test receiver/spectrum analyzer is 1 MHz for Peak detection at frequency above 1GHz.
3. The resolution bandwidth of test receiver/spectrum analyzer is 1 MHz and the video bandwidth is 10 Hz for Average detection (AV) at frequency above 1GHz.

4.2.5 DEVIATION FROM TEST STANDARD

No deviation

4.2.6 TEST SETUP

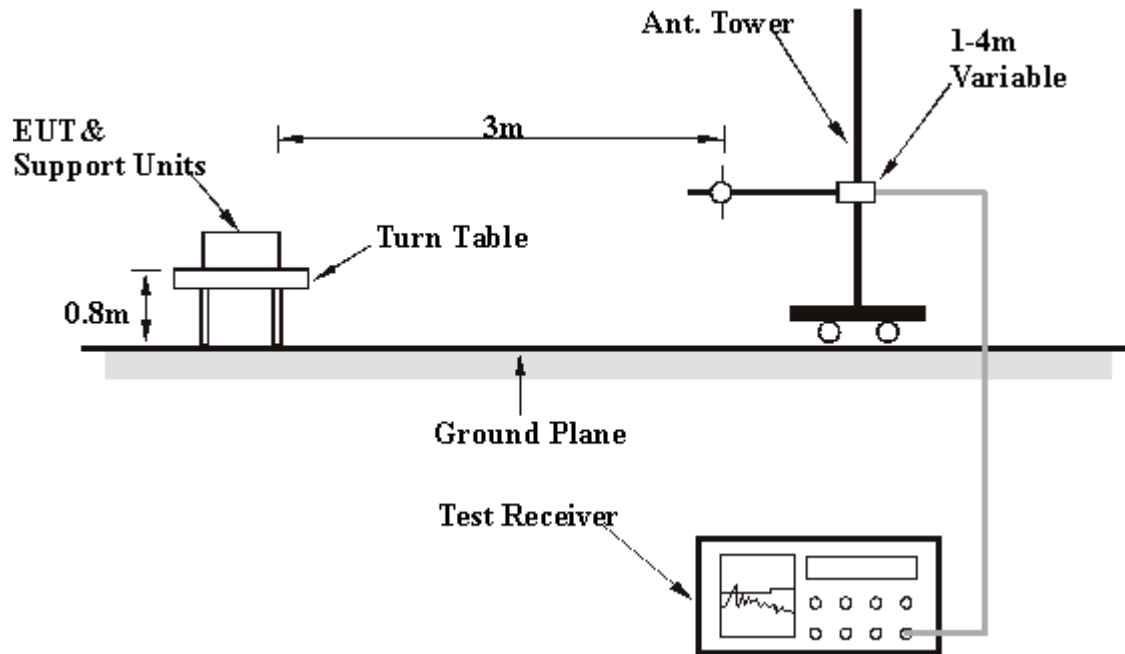

For the actual test configuration, please refer to the related item – Photographs of the Test Configuration.

4.2.7 EUT OPERATING CONDITION

Same as 4.1.6

4.2.8 TEST RESULTS

Below 1GHz Worst-Case Data (Antenna 1)

EUT	11a/b/g Wireless PCI Adapter	MEASUREMENT DETAIL	
MODEL	SL-3055	FREQUENCY RANGE	Below 1000MHz
CHANNEL	Channel 5	DETECTOR FUNCTION	Quasi-Peak
MODULATION TYPE	BPSK	ENVIRONMENTAL CONDITIONS	25deg. C, 64%RH, 991hPa
TRANSFER RATE	6Mbps	INPUT POWER (SYSTEM)	120Vac, 60 Hz
TESTED BY	Match Tsui	TEST MODE	A

ANTENNA POLARITY & TEST DISTANCE: HORIZONTAL AT 3 M

No.	Freq. (MHz)	Emission Level (dBuV/m)	Limit (dBuV/m)	Margin (dB)	Antenna Height (m)	Table Angle (Degree)	Raw Value (dBuV)	Correction Factor (dB/m)
1	99.98	33.84 QP	43.50	-9.66	2.00 H	64	23.09	10.74
2	438.22	37.00 QP	46.00	-9.00	1.00 H	169	19.39	17.61
3	473.21	37.17 QP	46.00	-8.83	1.00 H	283	18.94	18.22
4	539.30	36.93 QP	46.00	-9.07	1.50 H	355	17.54	19.39
5	574.29	35.89 QP	46.00	-10.11	1.50 H	115	15.65	20.23
6	768.68	34.53 QP	46.00	-11.47	1.00 H	130	11.01	23.52
7	817.27	34.57 QP	46.00	-11.43	1.00 H	127	10.72	23.85

ANTENNA POLARITY & TEST DISTANCE: VERTICAL AT 3 M

No.	Freq. (MHz)	Emission Level (dBuV/m)	Limit (dBuV/m)	Margin (dB)	Antenna Height (m)	Table Angle (Degree)	Raw Value (dBuV)	Correction Factor (dB/m)
1	63.05	27.83 QP	40.00	-12.17	1.00 V	331	14.72	13.11
2	438.22	36.94 QP	46.00	-9.06	1.00 V	148	19.33	17.61
3	473.21	36.95 QP	46.00	-9.05	1.00 V	223	18.73	18.22
4	506.25	34.78 QP	46.00	-11.22	1.00 V	160	16.07	18.71
5	537.35	37.09 QP	46.00	-8.91	1.50 V	331	17.73	19.35
6	574.29	35.10 QP	46.00	-10.90	1.50 V	106	14.86	20.23
7	644.27	33.66 QP	46.00	-12.34	1.50 V	322	12.15	21.51
8	675.37	34.81 QP	46.00	-11.19	1.00 V	148	12.89	21.92
9	799.78	32.11 QP	46.00	-13.89	1.50 V	136	8.41	23.70
10	914.47	34.59 QP	46.00	-11.41	1.00 V	346	9.34	25.25
11	947.52	35.04 QP	46.00	-10.96	1.00 V	340	9.46	25.59

- REMARKS:**
1. Emission level(dBuV/m)=Raw Value(dBuV) + Correction Factor(dB/m)
 2. Correction Factor(dB/m) = Antenna Factor (dB/m) + Cable Factor (dB)
 3. The other emission levels were very low against the limit.
 4. Margin value = Emission level – Limit value



Below 1GHz Worst-Case Data (Antenna 2)

EUT	11a/b/g Wireless PCI Adapter	MEASUREMENT DETAIL	
MODEL	SL-3055	FREQUENCY RANGE	Below 1000MHz
CHANNEL	Channel 5	DETECTOR FUNCTION	Quasi-Peak
MODULATION TYPE	BPSK	ENVIRONMENTAL CONDITIONS	25deg. C, 64%RH, 991hPa
TRANSFER RATE	6Mbps	INPUT POWER (SYSTEM)	120Vac, 60 Hz
TESTED BY	Match Tsui	TEST MODE	B

ANTENNA POLARITY & TEST DISTANCE: HORIZONTAL AT 3 M								
No.	Freq. (MHz)	Emission Level (dBuV/m)	Limit (dBuV/m)	Margin (dB)	Antenna Height (m)	Table Angle (Degree)	Raw Value (dBuV)	Correction Factor (dB/m)
1	61.10	24.37 QP	40.00	-15.63	2.00 H	127	11.04	13.33
2	99.98	31.80 QP	43.50	-11.70	2.00 H	73	21.06	10.74
3	168.02	31.10 QP	43.50	-12.40	1.50 H	310	17.23	13.88
4	220.50	34.10 QP	46.00	-11.90	1.50 H	154	22.45	11.66
5	304.09	30.48 QP	46.00	-15.52	1.00 H	244	16.06	14.42
6	613.17	30.98 QP	46.00	-15.02	1.00 H	175	9.90	21.08
7	675.37	32.49 QP	46.00	-13.51	1.00 H	37	10.56	21.92
8	708.42	30.18 QP	46.00	-15.82	1.00 H	37	7.74	22.44
9	739.52	30.51 QP	46.00	-15.49	1.00 H	172	7.34	23.17
10	811.44	31.62 QP	46.00	-14.38	1.50 H	124	7.83	23.80
11	933.91	31.23 QP	46.00	-14.77	1.50 H	178	5.78	25.45

- REMARKS:**
1. Emission level(dBuV/m)=Raw Value(dBuV) + Correction Factor(dB/m)
 2. Correction Factor(dB/m) = Antenna Factor (dB/m) + Cable Factor (dB)
 3. The other emission levels were very low against the limit.
 4. Margin value = Emission level – Limit value



EUT	11a/b/g Wireless PCI Adapter	MEASUREMENT DETAIL	
MODEL	SL-3055	FREQUENCY RANGE	Below 1000MHz
CHANNEL	Channel 5	DETECTOR FUNCTION	Quasi-Peak
MODULATION TYPE	BPSK	ENVIRONMENTAL CONDITIONS	25deg. C, 64%RH, 991hPa
TRANSFER RATE	6Mbps	INPUT POWER (SYSTEM)	120Vac, 60 Hz
TESTED BY	Match Tsui	TEST MODE	B

ANTENNA POLARITY & TEST DISTANCE: VERTICAL AT 3 M								
No.	Freq. (MHz)	Emission Level (dBuV/m)	Limit (dBuV/m)	Margin (dB)	Antenna Height (m)	Table Angle (Degree)	Raw Value (dBuV)	Correction Factor (dB/m)
1	61.10	27.85 QP	40.00	-12.15	2.00 V	10	14.52	13.33
2	304.09	30.85 QP	46.00	-15.15	1.50 V	328	16.43	14.42
3	473.21	31.00 QP	46.00	-15.00	1.00 V	355	12.77	18.22
4	506.25	32.28 QP	46.00	-13.72	1.00 V	343	13.57	18.71
5	539.30	30.82 QP	46.00	-15.18	1.00 V	10	11.43	19.39
6	673.43	34.51 QP	46.00	-11.49	1.50 V	334	12.62	21.90
7	710.36	30.15 QP	46.00	-15.85	1.50 V	355	7.66	22.49
8	774.51	32.80 QP	46.00	-13.20	1.50 V	139	9.24	23.56
9	809.50	30.16 QP	46.00	-15.84	1.00 V	124	6.38	23.78
10	914.47	34.26 QP	46.00	-11.74	1.00 V	349	9.01	25.25
11	947.52	34.27 QP	46.00	-11.73	1.00 V	337	8.69	25.59

- REMARKS:**
1. Emission level(dBuV/m)=Raw Value(dBuV) + Correction Factor(dB/m)
 2. Correction Factor(dB/m) = Antenna Factor (dB/m) + Cable Factor (dB)
 3. The other emission levels were very low against the limit.
 4. Margin value = Emission level – Limit value



802.11a OFDM modulation (Antenna 1)

EUT	11a/b/g Wireless PCI Adapter	MEASUREMENT DETAIL	
MODEL	SL-3055	FREQUENCY RANGE	1 ~ 40 GHz
CHANNEL	Channel 1	DETECTOR FUNCTION	Peak(PK) Average (AV)
MODULATION TYPE	BPSK	ENVIRONMENTAL CONDITIONS	24deg. C, 63%RH, 991hPa
TRANSFER RATE	6Mbps	INPUT POWER (SYSTEM)	120Vac, 60 Hz
TESTED BY	Match Tsui	TEST MODE	A

ANTENNA POLARITY & TEST DISTANCE: HORIZONTAL AT 3 M

No.	Freq. (MHz)	Emission Level (dBuV/m)	Limit (dBuV/m)	Margin (dB)	Antenna Height (m)	Table Angle (Degree)	Raw Value (dBuV)	Correction Factor (dB/m)
1	3543.00	43.60 PK	68.30	-24.70	1.00 H	131	10.57	33.03
2	#5150.00	44.46 PK	74.00	-29.54	1.04 H	319	7.41	37.05
2	#5150.00	34.62 AV	54.00	-19.38	1.04 H	319	-2.44	37.05
3	*5180.00	102.71 PK			1.04 H	319	65.62	37.09
3	*5180.00	92.87 AV			1.04 H	319	55.78	37.09
4	10360.00	53.95 PK	68.30	-14.35	1.04 H	187	7.89	46.06

ANTENNA POLARITY & TEST DISTANCE: VERTICAL AT 3 M

No.	Freq. (MHz)	Emission Level (dBuV/m)	Limit (dBuV/m)	Margin (dB)	Antenna Height (m)	Table Angle (Degree)	Raw Value (dBuV)	Correction Factor (dB/m)
1	3453.00	46.14 PK	68.30	-22.16	1.24 V	360	13.26	32.88
2	#5150.00	53.46 PK	74.00	-20.54	1.40 V	43	16.41	37.05
2	#5150.00	44.14 AV	54.00	-9.86	1.40 V	43	7.09	37.05
3	*5180.00	111.71 PK			1.40 V	43	74.62	37.09
3	*5180.00	102.39 AV			1.40 V	43	65.30	37.09
4	10360.00	54.14 PK	68.30	-14.16	1.10 V	360	8.08	46.06

- NOTE:**
1. Emission level(dBuV/m)=Raw Value(dBuV) + Correction Factor(dB/m)
 2. Correction Factor(dB/m) = Antenna Factor (dB/m) + Cable Factor (dB)
 3. The other emission levels were very low against the limit.
 4. Margin value = Emission level – Limit value
 5. "*" : Fundamental frequency
 6. "#"The radiated frequency falling in the restricted band.



EUT	11a/b/g Wireless PCI Adapter	MEASUREMENT DETAIL	
MODEL	SL-3055	FREQUENCY RANGE	1 ~ 40 GHz
CHANNEL	Channel 4	DETECTOR FUNCTION	Peak(PK) Average (AV)
MODULATION TYPE	BPSK	ENVIRONMENTAL CONDITIONS	24deg. C, 63%RH, 991hPa
TRANSFER RATE	6Mbps	INPUT POWER (SYSTEM)	120Vac, 60 Hz
TESTED BY	Match Tsui	TEST MODE	A

ANTENNA POLARITY & TEST DISTANCE: HORIZONTAL AT 3 M

No.	Freq. (MHz)	Emission Level (dBuV/m)	Limit (dBuV/m)	Margin (dB)	Antenna Height (m)	Table Angle (Degree)	Raw Value (dBuV)	Correction Factor (dB/m)
1	3493.00	44.96 PK	68.30	-23.34	1.18 H	274	12.06	32.91
2	*5240.00	99.62 PK			1.00 H	110	62.42	37.20
2	*5240.00	90.76 AV			1.00 H	110	53.56	37.20
3	10480.00	54.49 PK	68.30	-13.81	1.07 H	178	8.13	46.36

ANTENNA POLARITY & TEST DISTANCE: VERTICAL AT 3 M

No.	Freq. (MHz)	Emission Level (dBuV/m)	Limit (dBuV/m)	Margin (dB)	Antenna Height (m)	Table Angle (Degree)	Raw Value (dBuV)	Correction Factor (dB/m)
1	3493.00	46.71 PK	68.30	-21.59	1.08 V	360	13.81	32.91
2	*5240.00	112.84 PK			1.12 V	39	75.64	37.20
2	*5240.00	103.01 AV			1.12 V	39	65.81	37.20
3	10480.00	54.70 PK	68.30	-13.60	1.07 V	355	8.34	46.36

- NOTE:**
1. Emission level(dBuV/m)=Raw Value(dBuV) + Correction Factor(dB/m)
 2. Correction Factor(dB/m) = Antenna Factor (dB/m) + Cable Factor (dB)
 3. The other emission levels were very low against the limit.
 4. Margin value = Emission level – Limit value
 5. "*" : Fundamental frequency
 6. "#": The radiated frequency falling in the restricted band.



EUT	11a/b/g Wireless PCI Adapter	MEASUREMENT DETAIL	
MODEL	SL-3055	FREQUENCY RANGE	1 ~ 40 GHz
CHANNEL	Channel 5	DETECTOR FUNCTION	Peak(PK) Average (AV)
MODULATION TYPE	BPSK	ENVIRONMENTAL CONDITIONS	24deg. C, 63%RH, 991hPa
TRANSFER RATE	6Mbps	INPUT POWER (SYSTEM)	120Vac, 60 Hz
TESTED BY	Match Tsui	TEST MODE	A

ANTENNA POLARITY & TEST DISTANCE: HORIZONTAL AT 3 M

No.	Freq. (MHz)	Emission Level (dBuV/m)	Limit (dBuV/m)	Margin (dB)	Antenna Height (m)	Table Angle (Degree)	Raw Value (dBuV)	Correction Factor (dB/m)
1	3506.00	44.59 PK	68.30	-23.71	1.33 H	271	11.66	32.93
2	*5260.00	102.83 PK			1.38 H	319	65.58	37.25
2	*5260.00	93.28 AV			1.38 H	319	56.03	37.25
3	10520.00	55.13 PK	68.30	-13.17	1.08 H	211	8.66	46.48

ANTENNA POLARITY & TEST DISTANCE: VERTICAL AT 3 M

No.	Freq. (MHz)	Emission Level (dBuV/m)	Limit (dBuV/m)	Margin (dB)	Antenna Height (m)	Table Angle (Degree)	Raw Value (dBuV)	Correction Factor (dB/m)
1	3506.00	47.23 PK	68.30	-21.07	1.10 V	5	14.30	32.93
2	*5260.00	114.25 PK			1.24 V	282	77.00	37.25
2	*5260.00	104.36 AV			1.24 V	282	67.11	37.25
3	10520.00	55.11 PK	68.30	-13.19	1.17 V	196	8.64	46.48

- NOTE:**
1. Emission level(dBuV/m)=Raw Value(dBuV) + Correction Factor(dB/m)
 2. Correction Factor(dB/m) = Antenna Factor (dB/m) + Cable Factor (dB)
 3. The other emission levels were very low against the limit.
 4. Margin value = Emission level – Limit value
 5. "*" : Fundamental frequency
 6. "#" The radiated frequency falling in the restricted band.



EUT	11a/b/g Wireless PCI Adapter	MEASUREMENT DETAIL	
MODEL	SL-3055	FREQUENCY RANGE	1 ~ 40 GHz
CHANNEL	Channel 8	DETECTOR FUNCTION	Peak(PK) Average (AV)
MODULATION TYPE	BPSK	ENVIRONMENTAL CONDITIONS	24deg. C, 63%RH, 991hPa
TRANSFER RATE	6Mbps	INPUT POWER (SYSTEM)	120Vac, 60 Hz
TESTED BY	Match Tsui	TEST MODE	A

ANTENNA POLARITY & TEST DISTANCE: HORIZONTAL AT 3 M

No.	Freq. (MHz)	Emission Level (dBuV/m)	Limit (dBuV/m)	Margin (dB)	Antenna Height (m)	Table Angle (Degree)	Raw Value (dBuV)	Correction Factor (dB/m)
1	3546.00	45.06 PK	68.30	-23.24	1.30 H	274	12.02	33.04
2	*5320.00	100.98 PK			1.29 H	282	63.62	37.36
2	*5320.00	91.59 AV			1.29 H	282	54.23	37.36
3	#5350.00	48.93 PK	74.00	-25.07	1.29 H	282	11.54	37.39
3	#5350.00	39.54 AV	54.00	-14.46	1.29 H	282	2.15	37.39
4	#10640.00	54.75 PK	74.00	-19.25	1.07 H	100	8.03	46.72
4	#10640.00	41.55 AV	54.00	-12.45	1.07 H	100	-5.17	46.72

ANTENNA POLARITY & TEST DISTANCE: VERTICAL AT 3 M

No.	Freq. (MHz)	Emission Level (dBuV/m)	Limit (dBuV/m)	Margin (dB)	Antenna Height (m)	Table Angle (Degree)	Raw Value (dBuV)	Correction Factor (dB/m)
1	3546.00	46.20 PK	68.30	-22.10	1.08 V	26	13.16	33.04
2	*5320.00	114.57 PK			1.11 V	40	77.21	37.36
2	*5320.00	104.41 AV			1.11 V	40	67.05	37.36
3	#5350.00	62.52 PK	74.00	-11.48	1.11 V	40	25.13	37.39
3	#5350.00	52.36 AV	54.00	-1.64	1.11 V	40	14.97	37.39
4	#10640.00	56.34 PK	74.00	-17.66	1.16 V	342	9.62	46.72
4	310640.00	44.39 AV	54.00	-9.61	1.16 V	342	-2.33	46.72

- NOTE:**
1. Emission level(dBuV/m)=Raw Value(dBuV) + Correction Factor(dB/m)
 2. Correction Factor(dB/m) = Antenna Factor (dB/m) + Cable Factor (dB)
 3. The other emission levels were very low against the limit.
 4. Margin value = Emission level – Limit value
 5. "*" : Fundamental frequency
 6. "#":The radiated frequency falling in the restricted band.

**802.11a OFDM modulation (Antenna 2)**

EUT	11a/b/g Wireless PCI Adapter	MEASUREMENT DETAIL	
MODEL	SL-3055	FREQUENCY RANGE	1 ~ 40 GHz
CHANNEL	Channel 1	DETECTOR FUNCTION	Peak(PK) Average (AV)
MODULATION TYPE	BPSK	ENVIRONMENTAL CONDITIONS	24deg. C, 63%RH, 991hPa
TRANSFER RATE	6Mbps	INPUT POWER (SYSTEM)	120Vac, 60 Hz
TESTED BY	Match Tsui	TEST MODE	B

ANTENNA POLARITY & TEST DISTANCE: HORIZONTAL AT 3 M

No.	Freq. (MHz)	Emission Level (dBuV/m)	Limit (dBuV/m)	Margin (dB)	Antenna Height (m)	Table Angle (Degree)	Raw Value (dBuV)	Correction Factor (dB/m)
1	#5150.00	45.01 PK	74.00	-28.99	1.11 H	333	7.95	37.05
1	#5150.00	35.17 AV	54.00	-18.83	1.11 H	333	-1.88	37.05
2	*5180.00	102.14 PK			1.11 H	333	65.05	37.09
2	*5180.00	92.57 AV			1.11 H	333	55.48	37.09
3	10360.00	58.28 PK	68.30	-10.02	1.10 H	185	12.22	46.06

ANTENNA POLARITY & TEST DISTANCE: VERTICAL AT 3 M

No.	Freq. (MHz)	Emission Level (dBuV/m)	Limit (dBuV/m)	Margin (dB)	Antenna Height (m)	Table Angle (Degree)	Raw Value (dBuV)	Correction Factor (dB/m)
1	3453.00	43.19 PK	68.30	-25.11	1.16 V	346	10.31	32.88
2	#5150.00	54.12 PK	74.00	-19.88	1.20 V	216	17.06	37.05
2	#5150.00	45.18 AV	54.00	-8.82	1.20 V	216	8.12	37.05
3	*5180.00	111.52 PK			1.20 V	216	74.43	37.09
3	*5180.00	102.58 AV			1.20 V	216	65.49	37.09
4	10360.00	54.57 PK	68.30	-13.73	1.20 V	1	8.51	46.06

- NOTE:**
1. Emission level(dBuV/m)=Raw Value(dBuV) + Correction Factor(dB/m)
 2. Correction Factor(dB/m) = Antenna Factor (dB/m) + Cable Factor (dB)
 3. The other emission levels were very low against the limit.
 4. Margin value = Emission level – Limit value
 5. "*" : Fundamental frequency
 6. "#"The radiated frequency falling in the restricted band.



EUT	11a/b/g Wireless PCI Adapter	MEASUREMENT DETAIL	
MODEL	SL-3055	FREQUENCY RANGE	1 ~ 40 GHz
CHANNEL	Channel 4	DETECTOR FUNCTION	Peak(PK) Average (AV)
MODULATION TYPE	BPSK	ENVIRONMENTAL CONDITIONS	24deg. C, 63%RH, 991hPa
TRANSFER RATE	6Mbps	INPUT POWER (SYSTEM)	120Vac, 60 Hz
TESTED BY	Match Tsui	TEST MODE	B

ANTENNA POLARITY & TEST DISTANCE: HORIZONTAL AT 3 M

No.	Freq. (MHz)	Emission Level (dBuV/m)	Limit (dBuV/m)	Margin (dB)	Antenna Height (m)	Table Angle (Degree)	Raw Value (dBuV)	Correction Factor (dB/m)
1	*5240.00	104.06 PK			1.10 H	324	66.86	37.20
1	*5240.00	94.49 AV			1.10 H	324	57.29	37.20
2	10480.00	58.13 PK	68.30	-10.17	1.09 H	214	11.77	46.36

ANTENNA POLARITY & TEST DISTANCE: VERTICAL AT 3 M

No.	Freq. (MHz)	Emission Level (dBuV/m)	Limit (dBuV/m)	Margin (dB)	Antenna Height (m)	Table Angle (Degree)	Raw Value (dBuV)	Correction Factor (dB/m)
1	3493.00	43.46 PK	68.30	-24.84	1.08 V	174	10.56	32.91
2	*5240.00	114.28 PK			1.16 V	216	77.08	37.20
2	*5240.00	103.98 AV			1.16 V	216	66.78	37.20
3	10480.00	55.02 PK	68.30	-13.28	1.11 V	169	8.66	46.36

- NOTE:**
1. Emission level(dBuV/m)=Raw Value(dBuV) + Correction Factor(dB/m)
 2. Correction Factor(dB/m) = Antenna Factor (dB/m) + Cable Factor (dB)
 3. The other emission levels were very low against the limit.
 4. Margin value = Emission level – Limit value
 5. "*" : Fundamental frequency
 6. "#": The radiated frequency falling in the restricted band.



EUT	11a/b/g Wireless PCI Adapter	MEASUREMENT DETAIL	
MODEL	SL-3055	FREQUENCY RANGE	1 ~ 40 GHz
CHANNEL	Channel 5	DETECTOR FUNCTION	Peak(PK) Average (AV)
MODULATION TYPE	BPSK	ENVIRONMENTAL CONDITIONS	24deg. C, 63%RH, 991hPa
TRANSFER RATE	6Mbps	INPUT POWER (SYSTEM)	120Vac, 60 Hz
TESTED BY	Match Tsui	TEST MODE	B

ANTENNA POLARITY & TEST DISTANCE: HORIZONTAL AT 3 M

No.	Freq. (MHz)	Emission Level (dBuV/m)	Limit (dBuV/m)	Margin (dB)	Antenna Height (m)	Table Angle (Degree)	Raw Value (dBuV)	Correction Factor (dB/m)
1	*5260.00	105.00 PK			1.21 H	316	67.75	37.25
1	*5260.00	95.08 AV			1.21 H	316	57.83	37.25
2	10520.00	64.84 PK	68.30	-3.46	1.21 H	316	18.37	46.48

ANTENNA POLARITY & TEST DISTANCE: VERTICAL AT 3 M

No.	Freq. (MHz)	Emission Level (dBuV/m)	Limit (dBuV/m)	Margin (dB)	Antenna Height (m)	Table Angle (Degree)	Raw Value (dBuV)	Correction Factor (dB/m)
1	3506.00	43.64 PK	68.30	-24.66	1.12 V	360	10.71	32.93
2	*5260.00	114.95 PK			1.12 V	216	77.70	37.25
2	*5260.00	105.37 AV			1.12 V	216	68.12	37.25
3	10520.00	58.93 PK	68.30	-9.37	1.11 V	23	12.46	46.48

- NOTE:**
1. Emission level(dBuV/m)=Raw Value(dBuV) + Correction Factor(dB/m)
 2. Correction Factor(dB/m) = Antenna Factor (dB/m) + Cable Factor (dB)
 3. The other emission levels were very low against the limit.
 4. Margin value = Emission level – Limit value
 5. "*" : Fundamental frequency
 6. "#" The radiated frequency falling in the restricted band.



EUT	11a/b/g Wireless PCI Adapter	MEASUREMENT DETAIL	
MODEL	SL-3055	FREQUENCY RANGE	1 ~ 40 GHz
CHANNEL	Channel 8	DETECTOR FUNCTION	Peak(PK) Average (AV)
MODULATION TYPE	BPSK	ENVIRONMENTAL CONDITIONS	24deg. C, 63%RH, 991hPa
TRANSFER RATE	6Mbps	INPUT POWER (SYSTEM)	120Vac, 60 Hz
TESTED BY	Match Tsui	TEST MODE	B

ANTENNA POLARITY & TEST DISTANCE: HORIZONTAL AT 3 M

No.	Freq. (MHz)	Emission Level (dBuV/m)	Limit (dBuV/m)	Margin (dB)	Antenna Height (m)	Table Angle (Degree)	Raw Value (dBuV)	Correction Factor (dB/m)
1	*5320.00	102.68 PK			1.00 H	328	65.32	37.36
1	*5320.00	93.06 AV			1.00 H	328	55.70	37.36
2	#5350.00	50.82 PK	74.00	-23.18	1.00 H	328	13.43	37.39
2	#5350.00	41.20 AV	54.00	-12.80	1.00 H	328	3.81	37.39
3	#10640.00	55.15 PK	74.00	-18.85	1.00 H	13	8.43	46.72
3	#10640.00	42.92 AV	54.00	-11.08	1.00 H	13	-3.80	46.72

ANTENNA POLARITY & TEST DISTANCE: VERTICAL AT 3 M

No.	Freq. (MHz)	Emission Level (dBuV/m)	Limit (dBuV/m)	Margin (dB)	Antenna Height (m)	Table Angle (Degree)	Raw Value (dBuV)	Correction Factor (dB/m)
1	3546.00	43.44 PK	68.30	-24.86	1.04 V	352	10.40	33.04
2	*5320.00	114.60 PK			1.08 V	216	77.24	37.36
2	*5320.00	104.60 AV			1.08 V	216	67.24	37.36
3	#5350.00	62.50 PK	74.00	-11.50	1.08 V	216	25.11	37.39
3	#5350.00	52.74 AV	54.00	-1.26	1.08 V	216	15.35	37.39
4	#10640.00	57.55 PK	74.00	-16.45	1.00 V	2	10.83	46.72
4	#10640.00	44.28 AV	54.00	-9.72	1.00 V	2	-2.44	46.72

- NOTE:**
1. Emission level(dBuV/m)=Raw Value(dBuV) + Correction Factor(dB/m)
 2. Correction Factor(dB/m) = Antenna Factor (dB/m) + Cable Factor (dB)
 3. The other emission levels were very low against the limit.
 4. Margin value = Emission level – Limit value
 5. "*" : Fundamental frequency
 6. "#"The radiated frequency falling in the restricted band.



802.11a Turbo OFDM modulation (Antenna 1)

EUT	11a/b/g Wireless PCI Adapter	MEASUREMENT DETAIL	
MODEL	SL-3055	FREQUENCY RANGE	1 ~ 40 GHz
CHANNEL	Channel 1	DETECTOR FUNCTION	Peak(PK) Average (AV)
MODULATION TYPE	BPSK	ENVIRONMENTAL CONDITIONS	24deg. C, 63%RH, 991hPa
TRANSFER RATE	12Mbps	INPUT POWER (SYSTEM)	120Vac, 60 Hz
TESTED BY	Match Tsui	TEST MODE	A

ANTENNA POLARITY & TEST DISTANCE: HORIZONTAL AT 3 M

No.	Freq. (MHz)	Emission Level (dBuV/m)	Limit (dBuV/m)	Margin (dB)	Antenna Height (m)	Table Angle (Degree)	Raw Value (dBuV)	Correction Factor (dB/m)
1	3473.00	43.71 PK	68.30	-24.59	1.12 H	291	10.81	32.89
2	#5150.00	43.66 PK	74.00	-30.34	1.00 H	296	6.60	37.05
2	#5150.00	32.89 AV	54.00	-21.11	1.00 H	296	-4.16	37.05
3	*5210.00	96.86 PK			1.00 H	296	59.73	37.13
3	*5210.00	88.09 AV			1.00 H	296	50.96	37.13
4	10420.00	54.00 PK	68.30	-14.30	1.11 H	168	7.88	46.12

ANTENNA POLARITY & TEST DISTANCE: VERTICAL AT 3 M

No.	Freq. (MHz)	Emission Level (dBuV/m)	Limit (dBuV/m)	Margin (dB)	Antenna Height (m)	Table Angle (Degree)	Raw Value (dBuV)	Correction Factor (dB/m)
1	3473.00	46.84 PK	68.30	-21.46	1.28 V	4	13.94	32.89
2	#5150.00	55.45 PK	74.00	-18.55	1.13 V	326	18.40	37.05
2	#5150.00	45.45 AV	54.00	-8.55	1.13 V	326	8.40	37.05
3	*5210.00	110.65 PK			1.13 V	326	73.52	37.13
3	*5210.00	100.65 AV			1.13 V	326	63.52	37.13
4	10420.00	54.82 PK	68.30	-13.48	1.04 V	206	8.70	46.12

- NOTE:**
1. Emission level(dBuV/m)=Raw Value(dBuV) + Correction Factor(dB/m)
 2. Correction Factor(dB/m) = Antenna Factor (dB/m) + Cable Factor (dB)
 3. The other emission levels were very low against the limit.
 4. Margin value = Emission level – Limit value
 5. "*" : Fundamental frequency
 6. "#"The radiated frequency falling in the restricted band.



EUT	11a/b/g Wireless PCI Adapter	MEASUREMENT DETAIL	
MODEL	SL-3055	FREQUENCY RANGE	1 ~ 40 GHz
CHANNEL	Channel 2	DETECTOR FUNCTION	Peak(PK) Average (AV)
MODULATION TYPE	BPSK	ENVIRONMENTAL CONDITIONS	24deg. C, 63%RH, 991hPa
TRANSFER RATE	12Mbps	INPUT POWER (SYSTEM)	120Vac, 60 Hz
TESTED BY	Match Tsui	TEST MODE	A

ANTENNA POLARITY & TEST DISTANCE: HORIZONTAL AT 3 M

No.	Freq. (MHz)	Emission Level (dBuV/m)	Limit (dBuV/m)	Margin (dB)	Antenna Height (m)	Table Angle (Degree)	Raw Value (dBuV)	Correction Factor (dB/m)
1	3500.00	44.05 PK	68.30	-24.25	1.17 H	272	11.14	32.91
2	*5250.00	97.56 PK			1.06 H	286	60.33	37.23
2	*5250.00	88.66 AV			1.06 H	286	51.44	37.23
3	10500.00	54.55 PK	68.30	-13.75	1.20 H	177	8.11	46.44

ANTENNA POLARITY & TEST DISTANCE: VERTICAL AT 3 M

No.	Freq. (MHz)	Emission Level (dBuV/m)	Limit (dBuV/m)	Margin (dB)	Antenna Height (m)	Table Angle (Degree)	Raw Value (dBuV)	Correction Factor (dB/m)
1	3500.00	46.40 PK	68.30	-21.90	1.08 V	13	13.49	32.91
2	*5250.00	109.88 PK			1.24 V	40	72.66	37.23
2	*5250.00	99.62 AV			1.24 V	40	62.40	37.23
3	10500.00	55.12 PK	68.30	-13.18	1.19 V	350	8.68	46.44

- NOTE:**
1. Emission level(dBuV/m)=Raw Value(dBuV) + Correction Factor(dB/m)
 2. Correction Factor(dB/m) = Antenna Factor (dB/m) + Cable Factor (dB)
 3. The other emission levels were very low against the limit.
 4. Margin value = Emission level – Limit value
 5. "*" : Fundamental frequency
 6. "#": The radiated frequency falling in the restricted band.



EUT	11a/b/g Wireless PCI Adapter	MEASUREMENT DETAIL	
MODEL	SL-3055	FREQUENCY RANGE	1 ~ 40 GHz
CHANNEL	Channel 3	DETECTOR FUNCTION	Peak(PK) Average (AV)
MODULATION TYPE	BPSK	ENVIRONMENTAL CONDITIONS	24deg. C, 63%RH, 991hPa
TRANSFER RATE	12Mbps	INPUT POWER (SYSTEM)	120Vac, 60 Hz
TESTED BY	Match Tsui	TEST MODE	A

ANTENNA POLARITY & TEST DISTANCE: HORIZONTAL AT 3 M

No.	Freq. (MHz)	Emission Level (dBuV/m)	Limit (dBuV/m)	Margin (dB)	Antenna Height (m)	Table Angle (Degree)	Raw Value (dBuV)	Correction Factor (dB/m)
1	3526.00	44.33 PK	68.30	-23.97	1.32 H	276	11.35	32.98
2	*5290.00	98.45 PK			1.08 H	286	61.13	37.32
2	*5290.00	88.73 AV			1.08 H	286	51.41	37.32
3	#5350.00	47.09 PK	74.00	-26.91	1.08 H	286	9.70	37.39
3	#5350.00	37.37 AV	54.00	-16.63	1.08 H	286	-0.02	37.39
4	10580.00	54.66 PK	68.30	-13.64	1.07 H	144	8.07	46.58

ANTENNA POLARITY & TEST DISTANCE: VERTICAL AT 3 M

No.	Freq. (MHz)	Emission Level (dBuV/m)	Limit (dBuV/m)	Margin (dB)	Antenna Height (m)	Table Angle (Degree)	Raw Value (dBuV)	Correction Factor (dB/m)
1	3526.00	46.39 PK	68.30	-21.91	1.08 V	360	13.41	32.98
2	*5290.00	112.61 PK			1.00 V	40	75.29	37.32
2	*5290.00	102.89 AV			1.00 V	40	65.57	37.32
3	#5350.00	61.25 PK	74.00	-12.75	1.00 V	40	23.86	37.39
3	#5350.00	51.53 AV	54.00	-2.47	1.00 V	40	14.14	37.39
4	10580.00	55.33 PK	68.30	-12.97	1.10 V	142	8.74	46.58

- NOTE:**
1. Emission level(dBuV/m)=Raw Value(dBuV) + Correction Factor(dB/m)
 2. Correction Factor(dB/m) = Antenna Factor (dB/m) + Cable Factor (dB)
 3. The other emission levels were very low against the limit.
 4. Margin value = Emission level – Limit value
 5. "*" : Fundamental frequency
 6. "#"The radiated frequency falling in the restricted band.



802.11a Turbo OFDM modulation (Antenna 2)

EUT	11a/b/g Wireless PCI Adapter	MEASUREMENT DETAIL	
MODEL	SL-3055	FREQUENCY RANGE	1 ~ 40 GHz
CHANNEL	Channel 1	DETECTOR FUNCTION	Peak(PK) Average (AV)
MODULATION TYPE	BPSK	ENVIRONMENTAL CONDITIONS	24deg. C, 66%RH, 991hPa
TRANSFER RATE	12Mbps	INPUT POWER (SYSTEM)	120Vac, 60 Hz
TESTED BY	Match Tsui	TEST MODE	B

ANTENNA POLARITY & TEST DISTANCE: HORIZONTAL AT 3 M

No.	Freq. (MHz)	Emission Level (dBuV/m)	Limit (dBuV/m)	Margin (dB)	Antenna Height (m)	Table Angle (Degree)	Raw Value (dBuV)	Correction Factor (dB/m)
1	*5210.00	101.79 PK			1.08 H	358	64.66	37.13
1	*5210.00	91.77 AV			1.08 H	358	54.64	37.13
2	10420.00	53.83 PK	68.30	-14.47	1.07 H	150	7.71	46.12

ANTENNA POLARITY & TEST DISTANCE: VERTICAL AT 3 M

No.	Freq. (MHz)	Emission Level (dBuV/m)	Limit (dBuV/m)	Margin (dB)	Antenna Height (m)	Table Angle (Degree)	Raw Value (dBuV)	Correction Factor (dB/m)
1	3473.00	44.13 PK	68.30	-24.17	1.13 V	322	11.23	32.89
2	#5150.00	53.36 PK	74.00	-20.64	1.23 V	360	16.30	37.05
2	#5150.00	42.86 AV	54.00	-11.14	1.23 V	360	5.80	37.05
3	*5210.00	107.48 PK			1.23 V	360	70.35	37.13
3	*5210.00	96.98 AV			1.23 V	360	59.85	37.13
4	10420.00	54.65 PK	68.30	-13.65	1.11 V	78	8.53	46.12

- NOTE:**
1. Emission level(dBuV/m)=Raw Value(dBuV) + Correction Factor(dB/m)
 2. Correction Factor(dB/m) = Antenna Factor (dB/m) + Cable Factor (dB)
 3. The other emission levels were very low against the limit.
 4. Margin value = Emission level – Limit value
 5. "*" : Fundamental frequency
 6. "#":The radiated frequency falling in the restricted band.



EUT	11a/b/g Wireless PCI Adapter	MEASUREMENT DETAIL	
MODEL	SL-3055	FREQUENCY RANGE	1 ~ 40 GHz
CHANNEL	Channel 2	DETECTOR FUNCTION	Peak(PK) Average (AV)
MODULATION TYPE	BPSK	ENVIRONMENTAL CONDITIONS	24deg. C, 66%RH, 991hPa
TRANSFER RATE	12Mbps	INPUT POWER (SYSTEM)	120Vac, 60 Hz
TESTED BY	Match Tsui	TEST MODE	B

ANTENNA POLARITY & TEST DISTANCE: HORIZONTAL AT 3 M

No.	Freq. (MHz)	Emission Level (dBuV/m)	Limit (dBuV/m)	Margin (dB)	Antenna Height (m)	Table Angle (Degree)	Raw Value (dBuV)	Correction Factor (dB/m)
1	*5250.00	100.97 PK			1.00 H	1	63.74	37.23
1	*5250.00	91.94 AV			1.00 H	1	54.72	37.23
2	10500.00	54.63 PK	68.30	-13.67	1.04 H	195	8.19	46.44

ANTENNA POLARITY & TEST DISTANCE: VERTICAL AT 3 M

No.	Freq. (MHz)	Emission Level (dBuV/m)	Limit (dBuV/m)	Margin (dB)	Antenna Height (m)	Table Angle (Degree)	Raw Value (dBuV)	Correction Factor (dB/m)
1	3500.00	44.45 PK	68.30	-23.85	1.11 V	186	11.54	32.91
2	*5250.00	107.15 PK			1.35 V	15	69.92	37.23
2	*5250.00	97.55 AV			1.35 V	15	60.32	37.23
3	10500.00	55.20 PK	68.30	-13.10	1.08 V	117	8.76	46.44

- NOTE:**
1. Emission level(dBuV/m)=Raw Value(dBuV) + Correction Factor(dB/m)
 2. Correction Factor(dB/m) = Antenna Factor (dB/m) + Cable Factor (dB)
 3. The other emission levels were very low against the limit.
 4. Margin value = Emission level – Limit value
 5. "*" : Fundamental frequency
 6. "#"The radiated frequency falling in the restricted band.



EUT	11a/b/g Wireless PCI Adapter	MEASUREMENT DETAIL	
MODEL	SL-3055	FREQUENCY RANGE	1 ~ 40 GHz
CHANNEL	Channel 3	DETECTOR FUNCTION	Peak(PK) Average (AV)
MODULATION TYPE	BPSK	ENVIRONMENTAL CONDITIONS	24deg. C, 66%RH, 991hPa
TRANSFER RATE	12Mbps	INPUT POWER (SYSTEM)	120Vac, 60 Hz
TESTED BY	Match Tsui	TEST MODE	B

ANTENNA POLARITY & TEST DISTANCE: HORIZONTAL AT 3 M

No.	Freq. (MHz)	Emission Level (dBuV/m)	Limit (dBuV/m)	Margin (dB)	Antenna Height (m)	Table Angle (Degree)	Raw Value (dBuV)	Correction Factor (dB/m)
1	*5290.00	101.57 PK			1.35 H	18	64.25	37.32
1	*5290.00	92.03 AV			1.35 H	18	54.71	37.32
2	#5350.00	51.15 PK	74.00	-22.85	1.35 H	18	13.76	37.39
2	#5350.00	41.61 AV	54.00	-12.39	1.35 H	18	4.22	37.39
3	10580.00	55.30 PK	68.30	-13.00	1.08 H	147	8.71	46.58

ANTENNA POLARITY & TEST DISTANCE: VERTICAL AT 3 M

No.	Freq. (MHz)	Emission Level (dBuV/m)	Limit (dBuV/m)	Margin (dB)	Antenna Height (m)	Table Angle (Degree)	Raw Value (dBuV)	Correction Factor (dB/m)
1	3526.00	45.65 PK	68.30	-22.65	1.20 V	168	12.67	32.98
2	*5290.00	109.60 PK			1.17 V	109	72.28	37.32
2	*5290.00	99.91 AV			1.17 V	109	62.59	37.32
3	#5350.00	59.18 PK	74.00	-14.82	1.17 V	109	21.79	37.39
3	#5350.00	49.49 AV	54.00	-4.51	1.17 V	109	12.10	37.39
4	10580.00	58.57 PK	68.30	-9.73	1.30 V	312	11.98	46.58

- NOTE:**
1. Emission level(dBuV/m)=Raw Value(dBuV) + Correction Factor(dB/m)
 2. Correction Factor(dB/m) = Antenna Factor (dB/m) + Cable Factor (dB)
 3. The other emission levels were very low against the limit.
 4. Margin value = Emission level – Limit value
 5. "*" : Fundamental frequency
 6. "#"The radiated frequency falling in the restricted band.



4.3 PEAK TRANSMIT POWER MEASUREMENT

4.3.1 LIMITS OF PEAK TRANSMIT POWER MEASUREMENT

Frequency Band	Limit
5.15 – 5.25GHz	The lesser of 50mW (17dBm) or 4dBm + 10logB
5.25 – 5.35GHz	The lesser of 250mW (24dBm) or 11dBm + 10logB
5.725 – 5.825GHz	The lesser of 1W (30dBm) or 17dBm + 10logB

NOTE: Where B is the 26dB emission bandwidth in MHz.

4.3.2 TEST INSTRUMENTS

Description & Manufacturer	Model No.	Serial No.	Calibrated Until
R&S SPECTRUM ANALYZER	FSEK30	100049	Aug. 12, 2005

NOTE: The calibration interval of the above test instruments is 12 months and the calibrations are traceable to NML/ROC and NIST/USA.

4.3.3 TEST PROCEDURE

1. The transmitter output was connected to the spectrum analyzer.
2. Set span to encompass the entire emission bandwidth of the signal.
3. Set RBW to 1MHz, VBW to 3MHz.
4. Using the spectrum analyzer's channel power measurement function to measure the output power.

NOTE:

The test is performed in accordance with FCC Public Notice: APPENDIX A Guidelines for Assessing Unlicensed National Information Infrastructure (U-NII) Devices – Part 15, Subpart E, August 2002.

The transmitter output operates continuously therefore Method # 1 is used.

4.3.4 DEVIATION FROM TEST STANDARD

No deviation

4.3.5 TEST SETUP

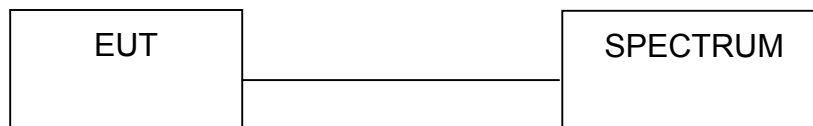

4.3.6 EUT OPERATING CONDITIONS

The software provided by client to enable the EUT under transmission condition continuously at specific channel frequencies individually.



4.3.7 TEST RESULTS

802.11a OFDM modulation

EUT	11a/b/g Wireless PCI Adapter	MODEL	SL-3055
MODULATION TYPE	BPSK	TRANSFER RATE	6Mbps
INPUT POWER (SYSTEM)	120Vac, 60 Hz	ENVIRONMENTAL CONDITIONS	25deg.C, 52%RH, 991hPa
TESTED BY	Gary Chang		

CHANNEL	CHANNEL FREQUENCY (MHz)	PEAK POWER OUTPUT (mW)	PEAK POWER OUTPUT (dBm)	PEAK POWER LIMIT (dBm)	26dBc Occupied Bandwidth (MHz)	PASS/FAIL
1	5180	28.445	14.54	17.00	24.72	PASS
4	5240	26.915	14.30	17.00	24.80	PASS
5	5260	43.451	16.38	24.00	29.20	PASS
8	5320	34.834	15.42	24.00	30.00	PASS

NOTE: The 26dBc Occupied Bandwidth plot, please refer to the following pages.



Peak Power Output:

CH 1

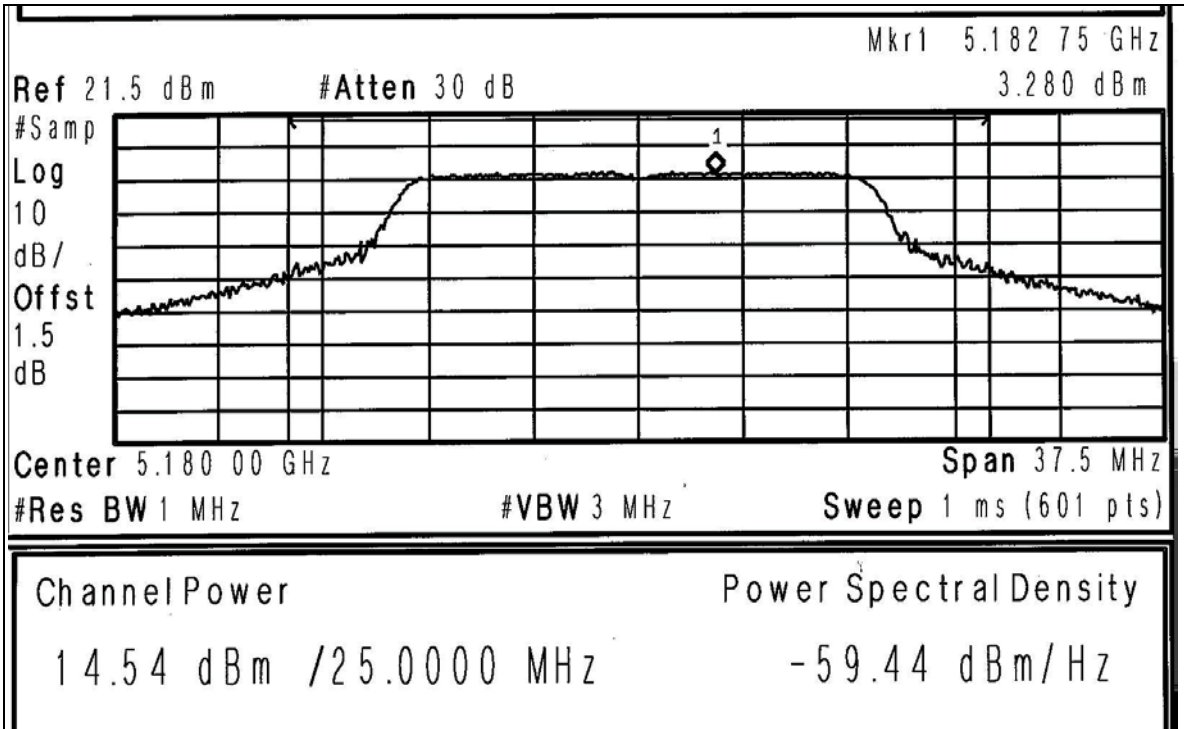

CH 4

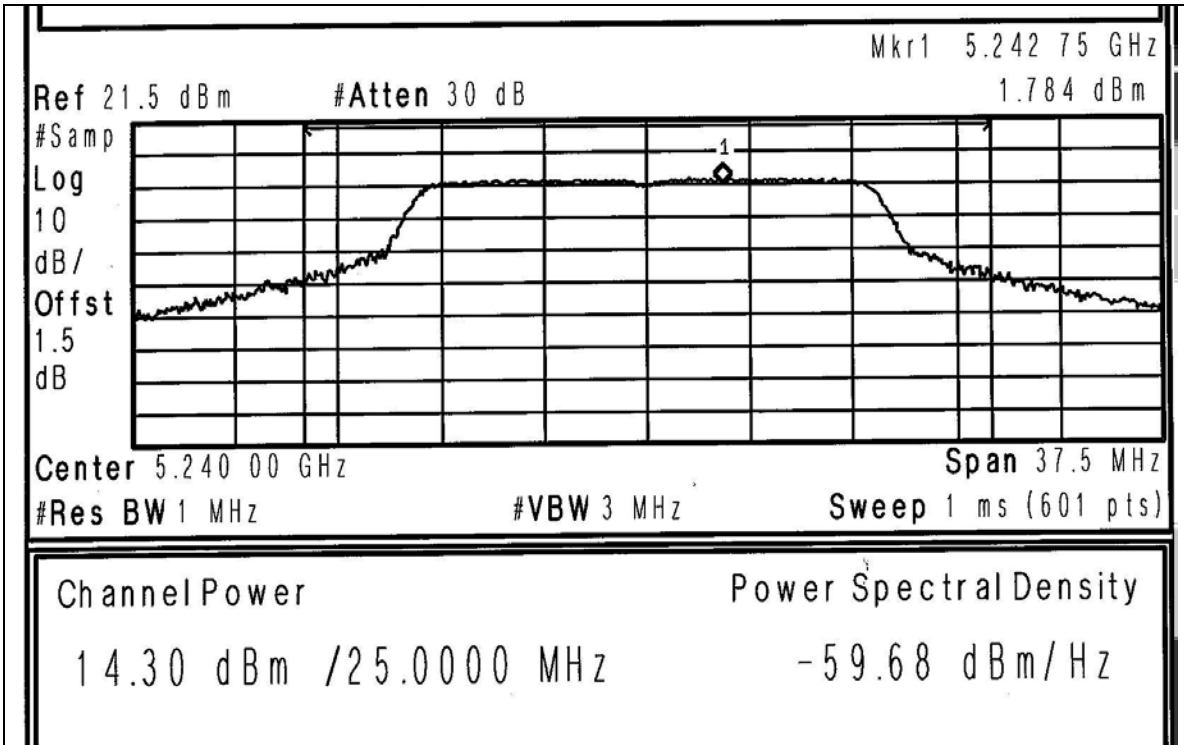



CH 5

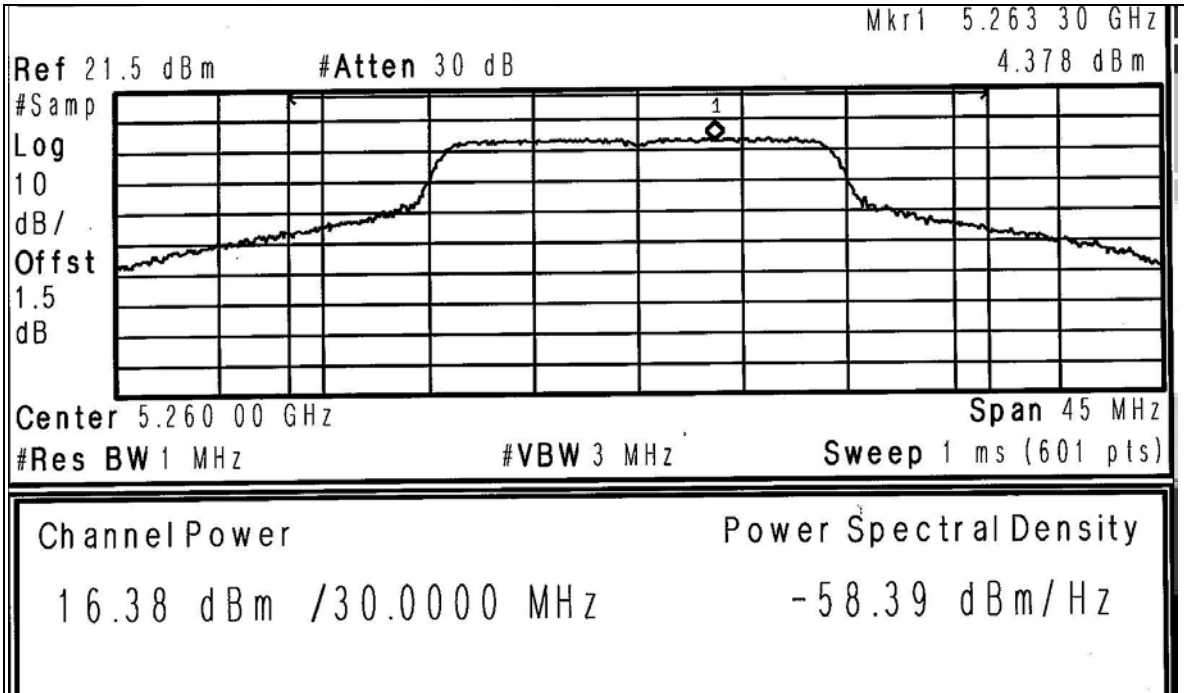

CH 8

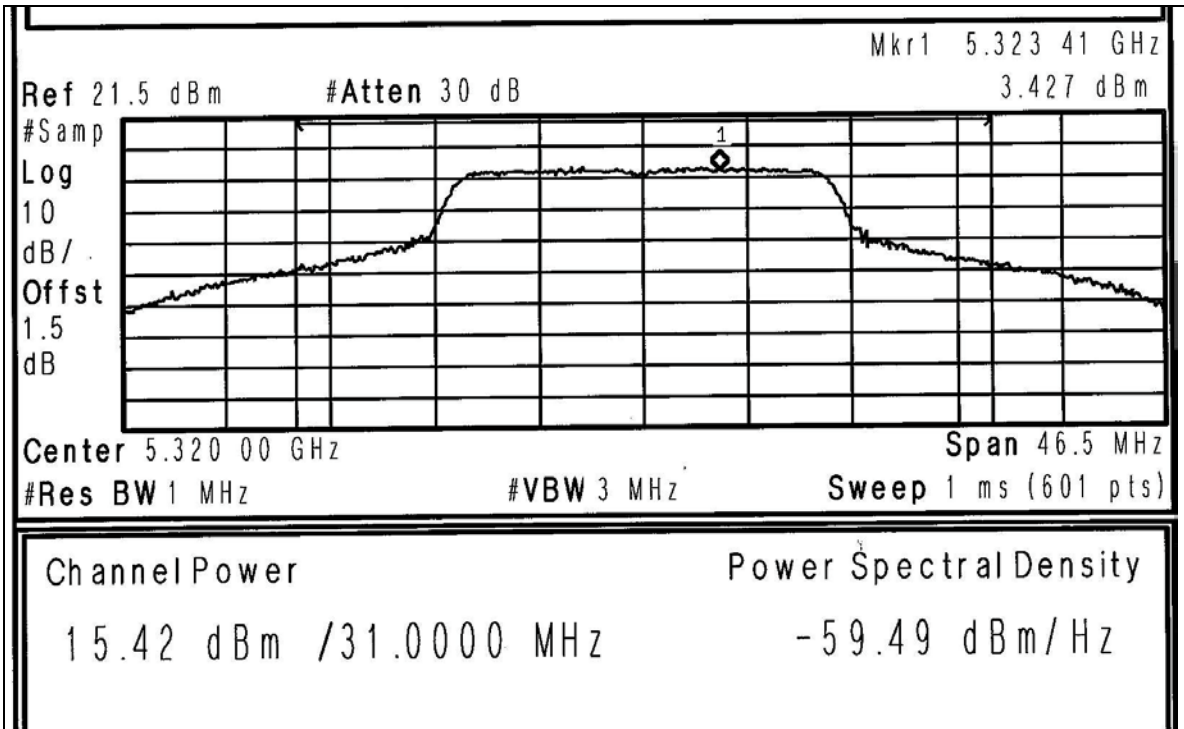



26dB Occupied Bandwidth:
CH 1

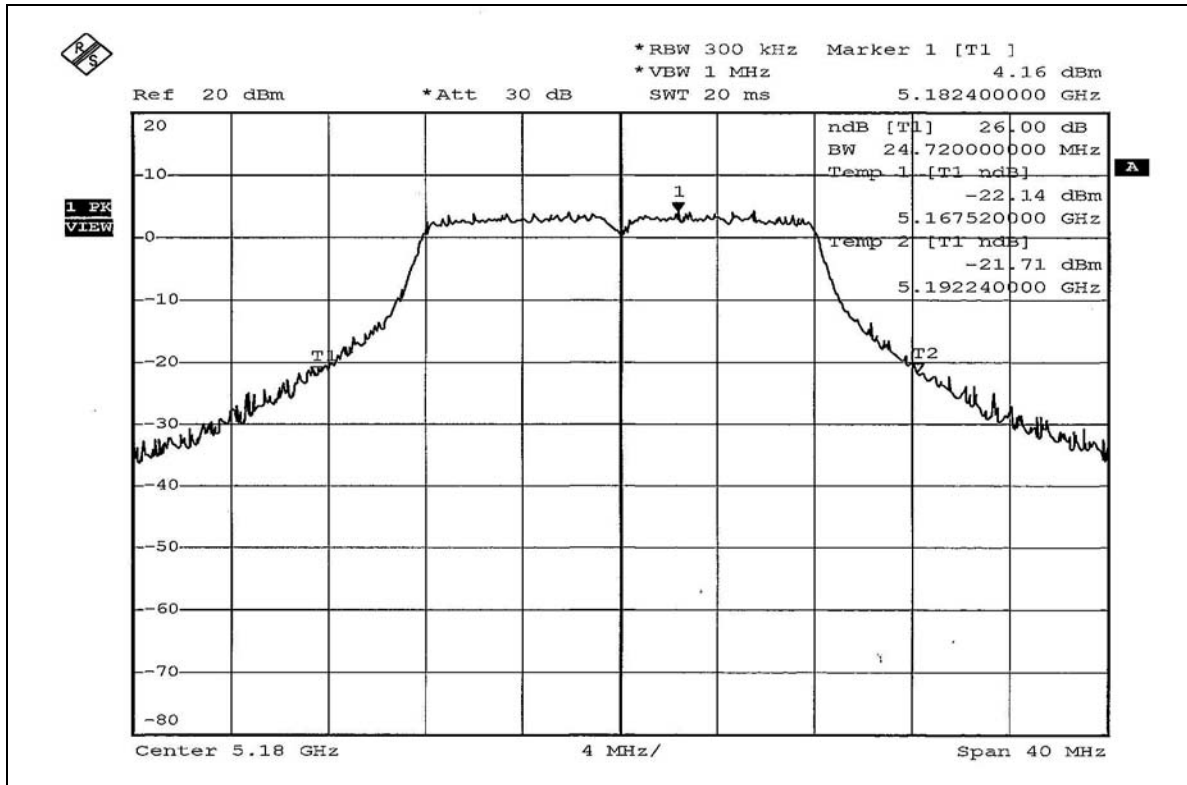

CH 4

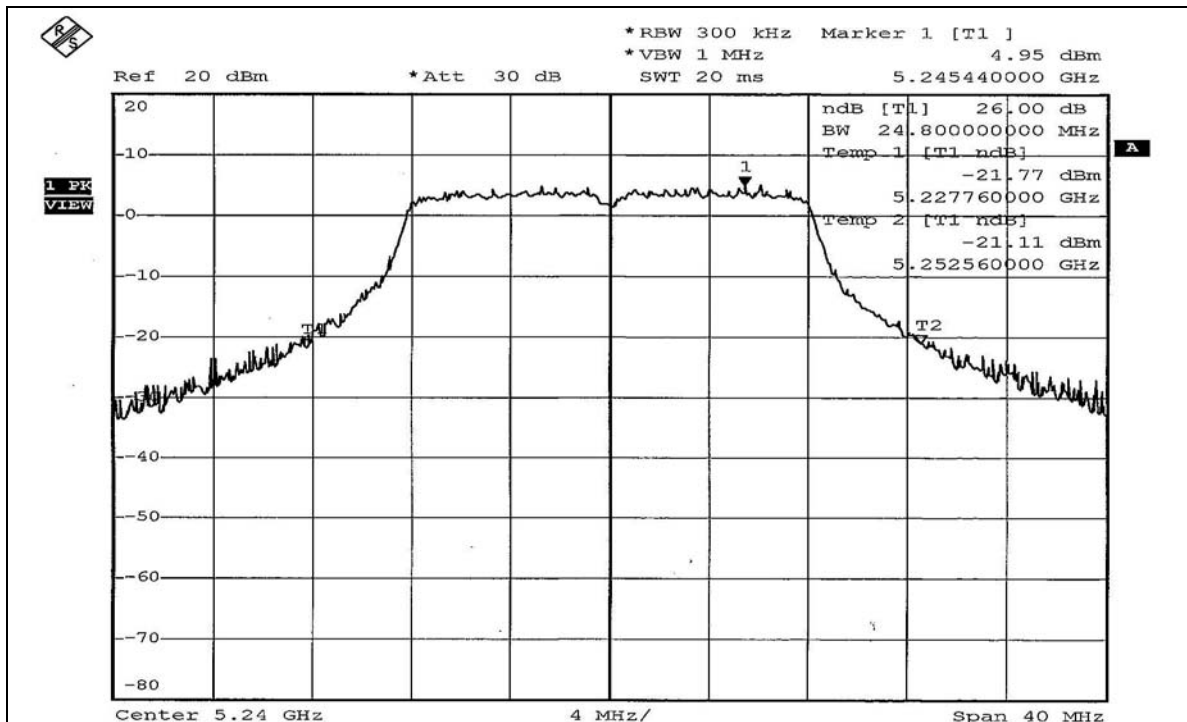



CH 5

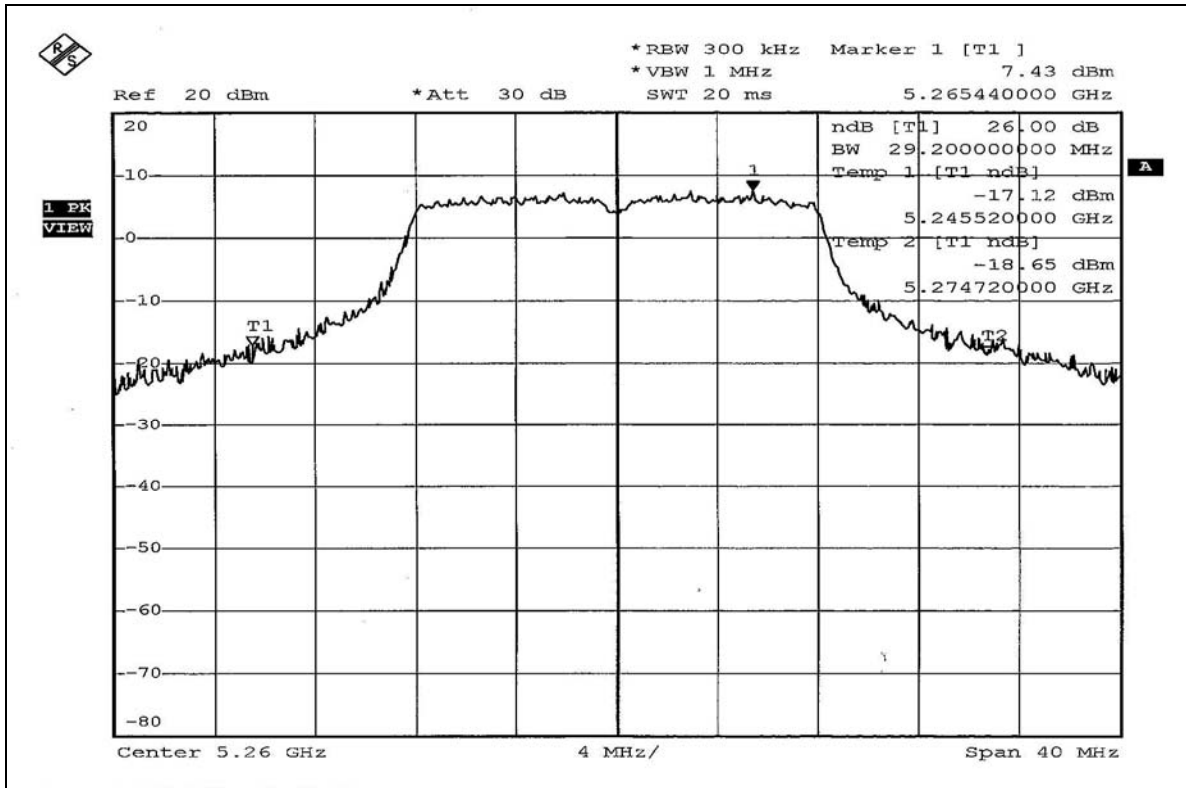

CH 8

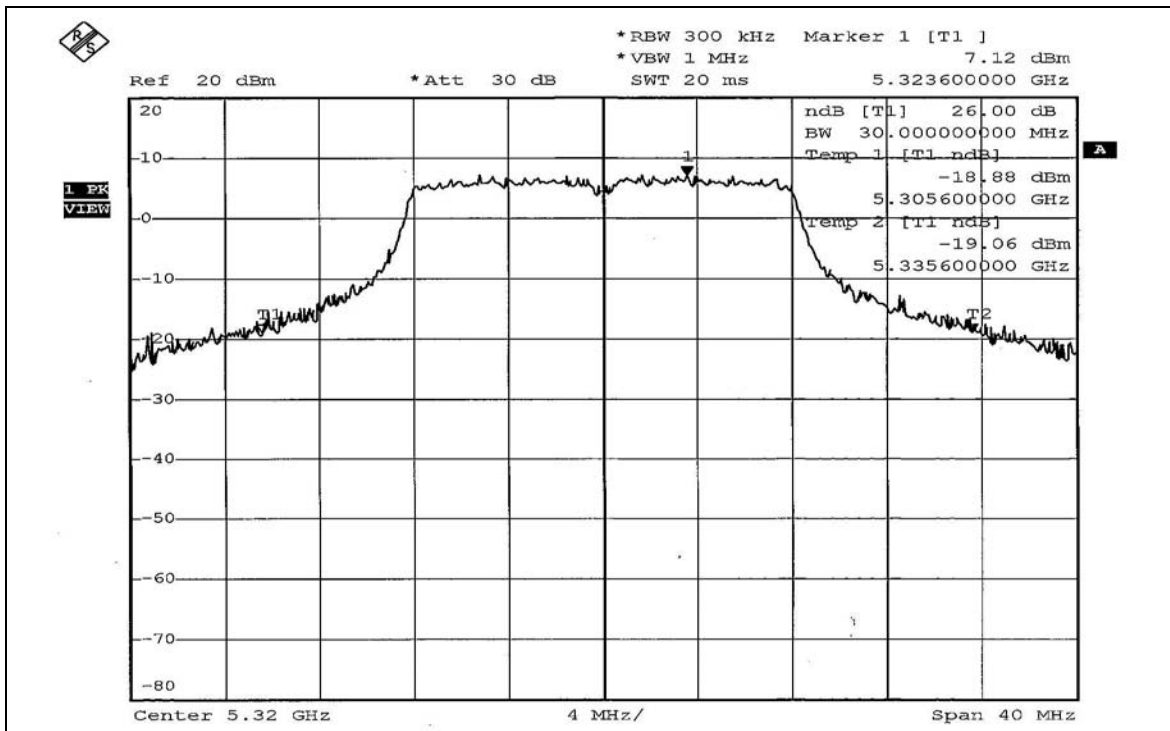

**802.11a Turbo OFDM modulation**

EUT	11a/b/g Wireless PCI Adapter	MODEL	SL-3055
MODULATION TYPE	BPSK	TRANSFER RATE	12Mbps
INPUT POWER (SYSTEM)	120Vac, 60 Hz	ENVIRONMENTAL CONDITIONS	25deg.C, 52%RH, 991hPa
TESTED BY	Gary Chang		

CHANNEL	CHANNEL FREQUENCY (MHz)	PEAK POWER OUTPUT (mW)	PEAK POWER OUTPUT (dBm)	PEAK POWER LIMIT (dBm)	26dBc Occupied Bandwidth (MHz)	PASS/FAIL
1	5210	25.293	14.03	17.00	44.40	PASS
2	5250	27.990	14.47	17.00	44.60	PASS
3	5290	36.983	15.68	24.00	59.80	PASS

NOTE: The 26dBc Occupied Bandwidth plot, please refer to the following pages.



Peak Power Output:
CH 1

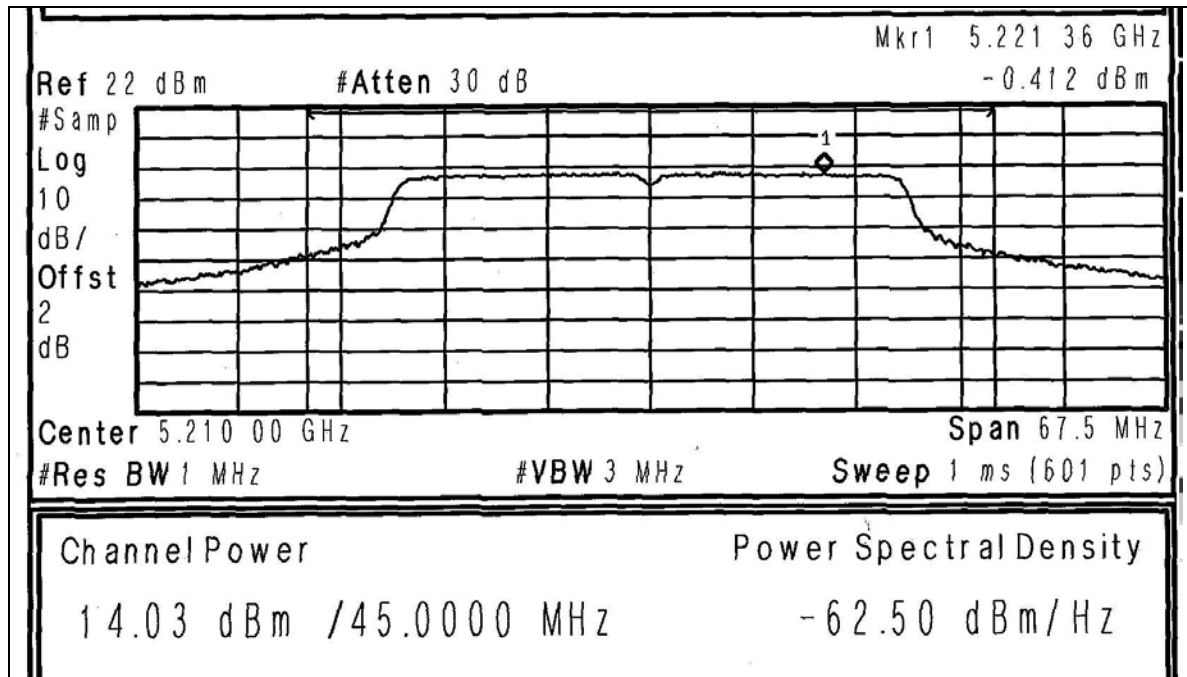

CH 2

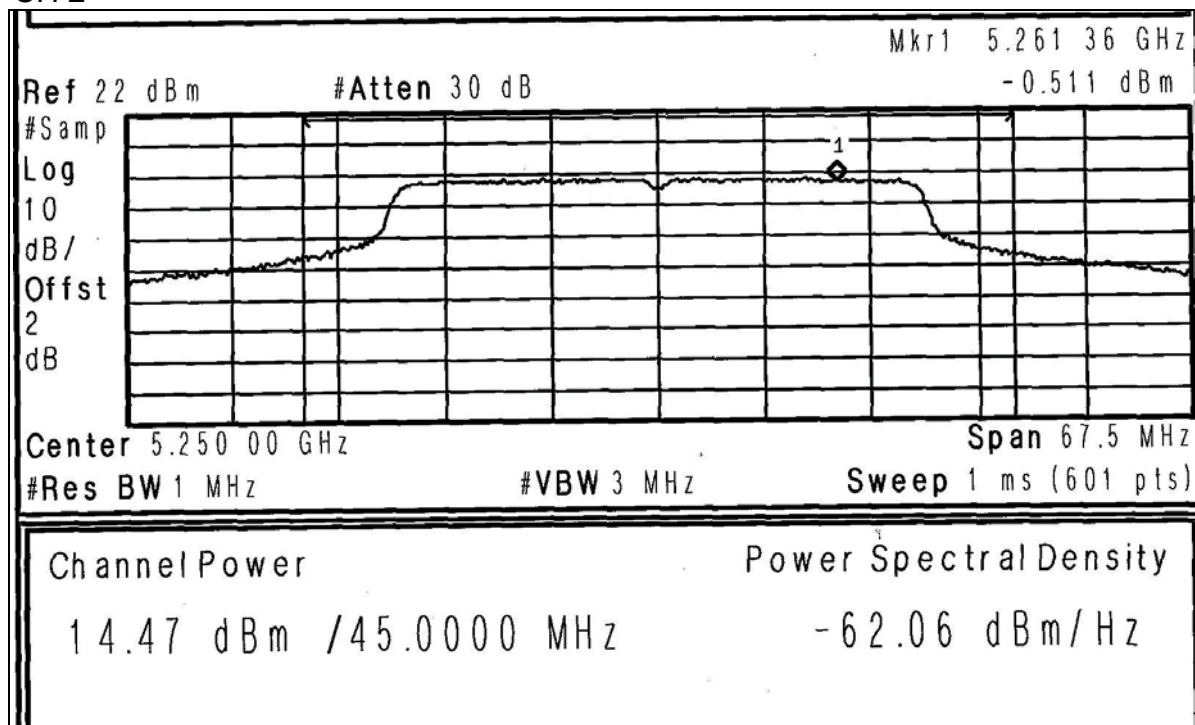



CH 3

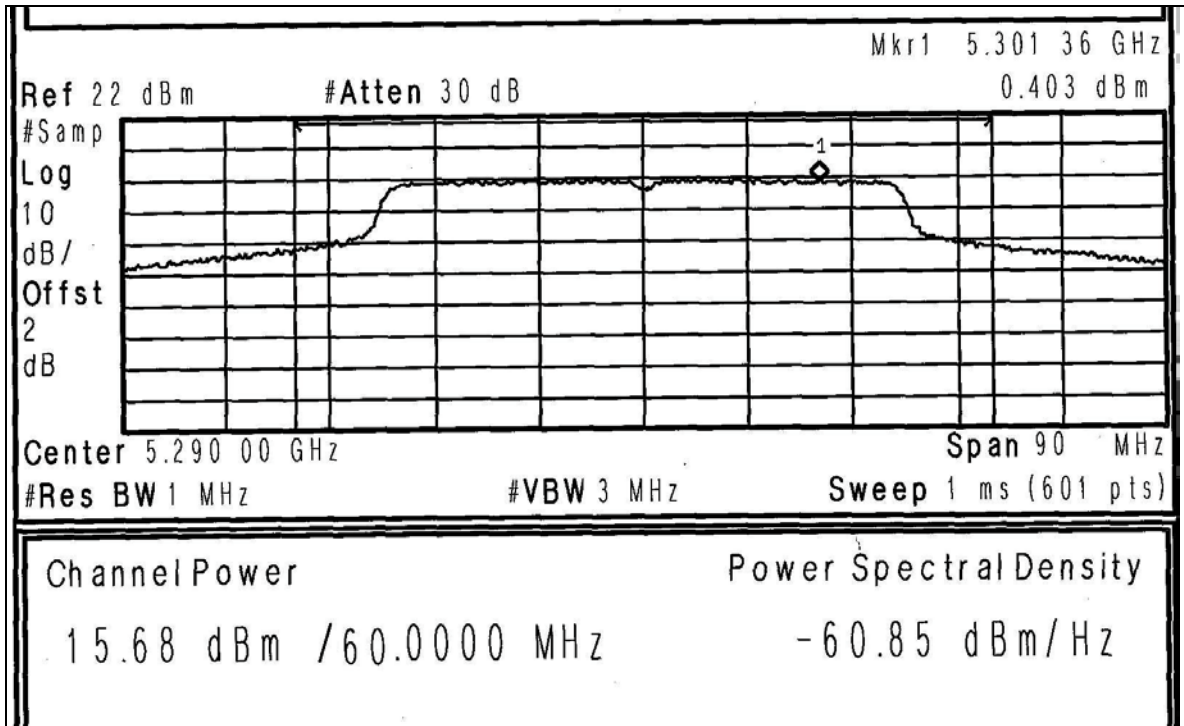



26dB Occupied Bandwidth:
CH 1

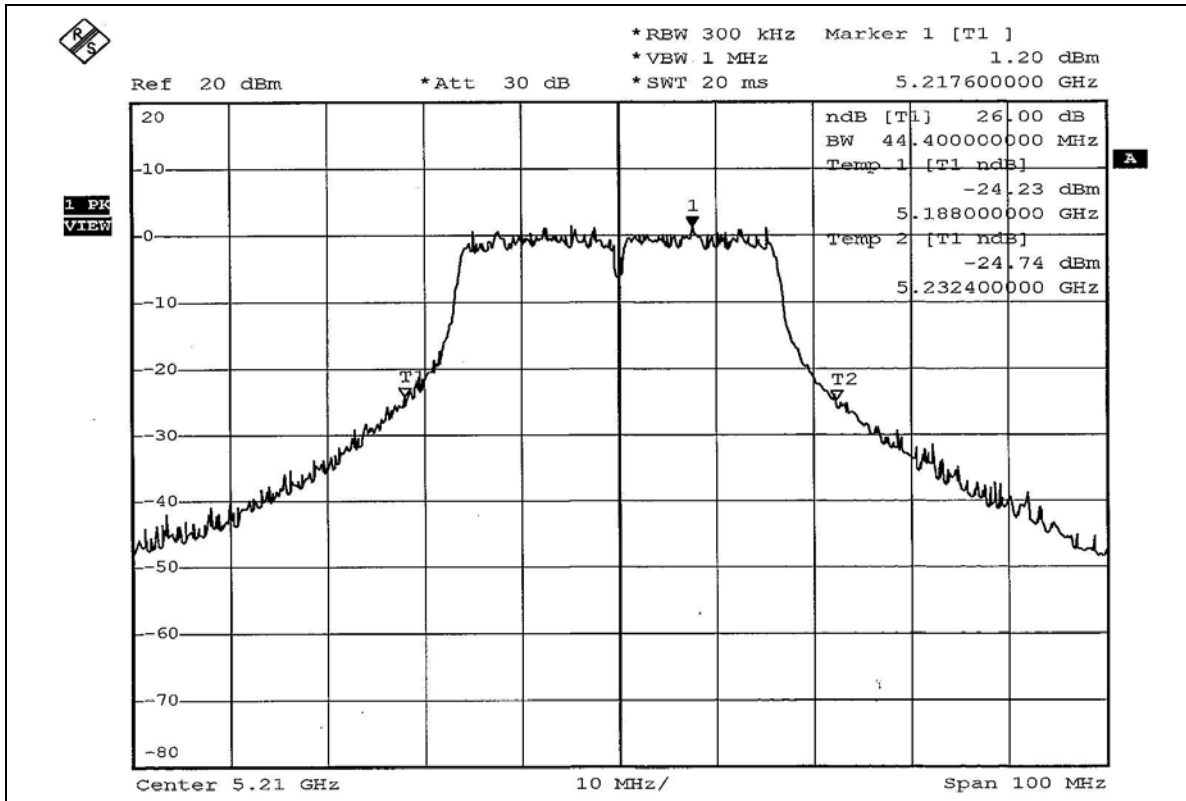

CH 2

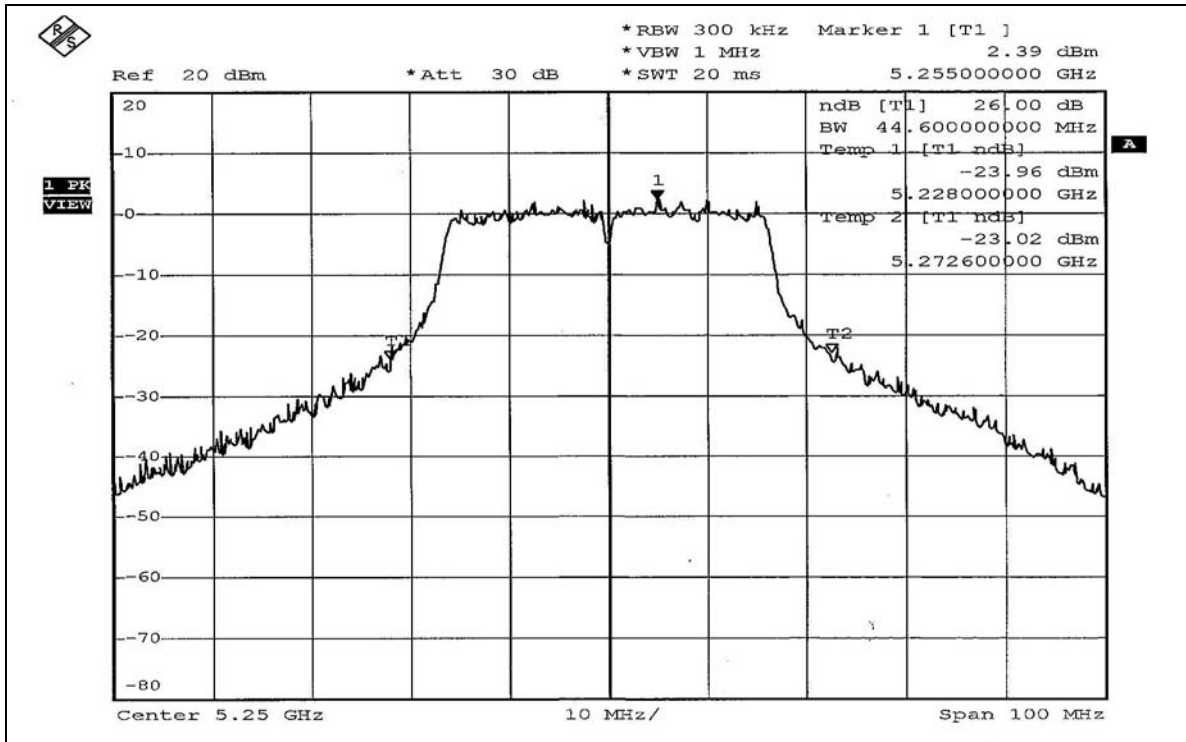



CH 3

