



FCC TEST REPORT (15.407)

REPORT NO.: RF940414L13A-1

MODEL NO.: SL-3050

RECEIVED: May 29, 2007

TESTED: June 25 to July 17, 2007

ISSUED: July 18, 2007

APPLICANT: 3Com Corporation

ADDRESS: 350 Campus Drive, Marlborough, MA
10752-3064. U.S.A.

ISSUED BY: Advance Data Technology Corporation

TEST LOCATION: No. 81-1, Lu Liao Keng, 9 Ling, Wu Lung
Tsuen, Chiung Lin Hsiang, Hsin Chu Hsien,
Taiwan, R.O.C.

This test report consists of 46 pages in total. It may be duplicated completely for legal use with the approval of the applicant. It should not be reproduced except in full, without the written approval of our laboratory. The client should not use it to claim product endorsement by TAF, A2LA or any government agencies. The test results in the report only apply to the tested sample.



No. 2177-01

Table of Contents

1.	CERTIFICATION.....	4
2.	SUMMARY OF TEST RESULTS.....	5
2.1	MEASUREMENT UNCERTAINTY.....	6
3.	GENERAL INFORMATION	7
3.1	GENERAL DESCRIPTION OF EUT	7
3.2	DESCRIPTION OF TEST MODES	9
3.2.1	TEST MODE APPLICABILITY AND TESTED CHANNEL DETAIL:.....	10
3.3	GENERAL DESCRIPTION OF APPLIED STANDARDS.....	11
3.4	DESCRIPTION OF SUPPORT UNITS	12
3.5	CONFIGURATION OF SYSTEM UNDER TEST	13
4.	TEST TYPES AND RESULTS.....	14
4.1	RADIATED EMISSION MEASUREMENT	14
4.1.1	LIMITS OF RADIATED EMISSION MEASUREMENT	14
4.1.2	LIMITS OF UNWANTED EMISSION OUT OF THE RESTRICTED BANDS.....	15
4.1.3	TEST INSTRUMENTS	16
4.1.4	TEST PROCEDURES.....	17
4.1.5	DEVIATION FROM TEST STANDARD	17
4.1.6	TEST SETUP.....	18
4.1.7	EUT OPERATING CONDITION	18
4.1.8	TEST RESULTS	19
4.2	PEAK TRANSMIT POWER MEASUREMENT	25
4.2.1	LIMITS OF PEAK TRANSMIT POWER MEASUREMENT	25
4.2.2	TEST INSTRUMENTS	25
4.2.3	TEST PROCEDURE	26
4.2.4	DEVIATION FROM TEST STANDARD	26
4.2.5	TEST SETUP.....	26
4.2.6	EUT OPERATING CONDITIONS.....	26
4.2.7	TEST RESULTS	27
4.3	PEAK POWER EXCURSION MEASUREMENT	31
4.3.1	LIMITS OF PEAK POWER EXCURSION MEASUREMENT	31
4.3.2	TEST INSTRUMENTS	31
4.3.3	TEST PROCEDURE	32
4.3.4	DEVIATION FROM TEST STANDARD	32
4.3.5	TEST SETUP.....	32



4.3.6	EUT OPERATING CONDITIONS.....	32
4.3.7	TEST RESULTS	33
4.4	PEAK POWER SPECTRAL DENSITY MEASUREMENT.....	35
4.4.1	LIMITS OF PEAK POWER SPECTRAL DENSITY MEASUREMENT	35
4.4.2	TEST INSTRUMENTS	35
4.4.3	TEST PROCEDURES.....	36
4.4.4	DEVIATION FROM TEST STANDARD	36
4.4.5	TEST SETUP.....	36
4.4.6	EUT OPERATING CONDITIONS.....	36
4.4.7	TEST RESULTS	37
4.5	BAND EDGES MEASUREMENT	39
4.5.1	TEST INSTRUMENTS	39
4.5.2	TEST PROCEDURE	39
4.5.3	EUT OPERATING CONDITION	39
4.5.4	TEST RESULTS	40
4.6	ANTENNA REQUIREMENT.....	44
4.6.1	STANDARD APPLICABLE	44
4.6.2	ANTENNA CONNECTED CONSTRUCTION	44
5.	INFORMATION ON THE TESTING LABORATORIES	45
6.	APPENDIX-A - MODIFICATIONS RECORDERS FOR ENGINEERING CHANGES TO THE EUT BY THE LAB	46



1. CERTIFICATION

PRODUCT: 11a/b/g Wireless PC Card with XJACK Antenna
BRAND NAME: 3Com
MODEL NO.: SL-3050
TEST SAMPLE: ENGINEERING SAMPLE
TESTED: June 25 to July 17, 2007
APPLICANT: 3Com Corporation
STANDARDS: FCC Part 15, Subpart E (Section 15.407)
ANSI C63.4-2003

The above equipment (Model: SL-3050) have been tested by **Advance Data Technology Corporation**, and found compliance with the requirement of the above standards. The test record, data evaluation & Equipment Under Test (EUT) configurations represented herein are true and accurate accounts of the measurements of the sample's EMC characteristics under the conditions specified in this report.

PREPARED BY :  , **DATE:** July 18, 2007
(Midoli Peng, Specialist)

TECHNICAL ACCEPTANCE :  , **DATE:** July 18, 2007
Responsible for RF (Hank Chung, Deputy Manager)

APPROVED BY :  , **DATE:** July 18, 2007
(May Chen, Deputy Manager)

2. SUMMARY OF TEST RESULTS

The EUT has been tested according to the following specifications:

APPLIED STANDARD: FCC Part 15, Subpart E (Section 15.407)			
Standard Section	Test Type	Result	Remark
15.407(b/1/2/3) (b)(5)	Electric Field Strength Spurious Emissions, 30MHz ~ 40000MHz	PASS	Meet the requirement of limit. Minimum passing margin is -2.1dB at 11400.00MHz
15.407(a/1/2/3)	Peak Transmit Power	PASS	Meet the requirement of limit.
15.407(a)(6)	Peak Power Excursion	PASS	Meet the requirement of limit.
15.407(a/1/2/3)	Peak Power Spectral Density	PASS	Meet the requirement of limit.

NOTE:

1. This report is prepared for FCC class II permissive change.

2.1 MEASUREMENT UNCERTAINTY

Where relevant, the following measurement uncertainty levels have been estimated for tests performed on the EUT as specified in CISPR 16-4:

This uncertainty represents an expanded uncertainty expressed at approximately the 95% confidence level using a coverage factor of $k=2$.

Measurement	Value
Radiated emissions (30MHz-1GHz)	3.89 dB
Radiated emissions (1GHz ~18GHz)	2.21 dB
Radiated emissions (18GHz ~40GHz)	1.88 dB

3. GENERAL INFORMATION

3.1 GENERAL DESCRIPTION OF EUT

EUT	11a/b/g Wireless PC Card with XJACK Antenna
MODEL NO.	SL-3050
FCC ID	O9C-SL3050
POWER SUPPLY	3.3Vdc from host equipment
MODULATION TYPE	CCK, DQPSK, DBPSK for DSSS 64QAM, 16QAM, QPSK, BPSK for OFDM
MODULATION TECHNOLOGY	DSSS, OFDM
TRANSFER RATE	802.11b: 11/5.5/2/1Mbps 802.11g: 54/48/36/24/18/12/9/6Mbps (Turbo mode: up to 108Mbps *see Note 3) 802.11a: 54/48/36/24/18/12/9/6Mbps (Turbo mode: up to 108Mbps *see Note 3)
FREQUENCY RANGE	802.11b & 802.11g: 2.412 ~ 2.462GHz 802.11a: 5.18 ~ 5.32GHz, 5.50 ~ 5.70GHz and 5.745 ~ 5.825GHz
NUMBER OF CHANNEL	802.11b & 802.11g: 11 for Normal mode / 1 for Turbo mode 802.11a: 19 for Normal mode / 2 for Turbo mode
CHANNEL SPACING	802.11b & 802.11g: 5MHz 802.11a: 20MHz for Normal mode / 40MHz for Turbo mode
OUTPUT POWER	For 802.11b: 66.222mW For 802.11g: 89.743mW For 802.11a (FCC15.247): 63.680mW For 802.11a (FCC15.407): 45.920mW
ANTENNA TYPE	2.4GHz band: Printed antenna with 2.5dBi gain 5GHz band: Printed antenna with 0dBi gain
DATA CABLE	NA
I/O PORTS	NA
ASSOCIATED DEVICES	NA



NOTE:

1. This report is prepared for FCC class II permissive change. The difference compared with the Report No.:RF940414L13 design is as the following:
 - ◆ Add new band: 5470~5725MHz
 - ◆ No Turbo mode for all DFS bands (previous 5.3G band Turbo disabled by firmware)
 - ◆ Add DFS test (5250MHz~5350MHz and 5470MHz ~5725MHz)
2. The EUT operates in both the 5GHz and 2.4GHz Bands and compatibility with 802.11a and 802.11b, 802.11g technology.
3. This EUT is capable of providing data rates of up to 108 Mbps in Turbo mode depending upon reception quality.
4. The above EUT information was declared by the manufacturer and for more detailed features description, please refer to the manufacturer's specifications or User's Manual.

3.2 DESCRIPTION OF TEST MODES

Operated in 5470MHz ~ 5725MHz bands:

Eleven channels are provided to this EUT.

Channel	Frequency
9	5500 MHz
10	5520 MHz
11	5540 MHz
12	5560 MHz
13	5580 MHz
14	5600 MHz
15	5620 MHz
16	5640 MHz
17	5660 MHz
18	5680 MHz
19	5700 MHz

3.2.1 TEST MODE APPLICABILITY AND TESTED CHANNEL DETAIL:

EUT configure mode	Applicable to				Description
	PLC	RE<1G	RE≥1G	APCM	
-	X	√	√	√	NA

Where PLC: Power Line Conducted Emission RE<1G RE: Radiated Emission below 1GHz
 RE≥1G: Radiated Emission above 1GHz APCM: Antenna Port Conducted Measurement

Radiated Emission Test (Below 1 GHz):

- Pre-Scan has been conducted to determine the worst-case mode from all possible combinations between available modulations, data rates and antenna ports (if EUT with antenna diversity architecture).
- Following channel(s) was (were) selected for the final test as listed below.

Mode	Available Channel	Tested Channel	Modulation Technology	Modulation Type	Data Rate (Mbps)
802.11a	9 to 19	9	OFDM	BPSK	6

Radiated Emission Test (Above 1 GHz):

- Pre-Scan has been conducted to determine the worst-case mode from all possible combinations between available modulations, data rates and antenna ports (if EUT with antenna diversity architecture).
- Following channel(s) was (were) selected for the final test as listed below.

Mode	Available Channel	Tested Channel	Modulation Technology	Modulation Type	Data Rate (Mbps)
802.11a	9 to 19	9, 14, 19	OFDM	BPSK	6

Bandedge Measurement:

- Pre-Scan has been conducted to determine the worst-case mode from all possible combinations between available modulations, data rates and antenna ports (if EUT with antenna diversity architecture).
- Following channel(s) was (were) selected for the final test as listed below.

Mode	Available Channel	Tested Channel	Modulation Technology	Modulation Type	Data Rate (Mbps)
802.11a	9 to 19	9, 19	OFDM	BPSK	6

Antenna Port Conducted Measurement:

- Pre-Scan has been conducted to determine the worst-case mode from all possible combinations between available modulations, data rates and antenna ports (if EUT with antenna diversity architecture).
- Following channel(s) was (were) selected for the final test as listed below.

Mode	Available Channel	Tested Channel	Modulation Technology	Modulation Type	Data Rate (Mbps)
802.11a	9 to 19	9, 14, 19	OFDM	BPSK	6



3.3 GENERAL DESCRIPTION OF APPLIED STANDARDS

The EUT is an 11a/b/g Wireless PC Card with XJACK Antenna. According to the specifications of the manufacturer, it must comply with the requirements of the following standards:

FCC Part 15, Subpart E (15.407)

ANSI C63.4-2003

All test items have been performed and recorded as per the above standards.

3.4 DESCRIPTION OF SUPPORT UNITS

The EUT has been tested as an independent unit together with other necessary accessories or support units. The following support units or accessories were used to form a representative test configuration during the tests.

NO.	PRODUCT	BRAND	MODEL NO.	SERIAL NO.	FCC ID
1	NOTEBOOK COMPUTER	DELL	PP05L	CN-04Y212-484 3-38E-0145	FCC DoC
2	PRINTER	HP	C2642A	MY79J1D00G	B94C2642X
3	MODEM	ACEEX	1414	0206026779	IFAXDM1414

NO.	SIGNAL CABLE DESCRIPTION OF THE ABOVE SUPPORT UNITS
1	NA
2	1.6 m shielded cable without core
3	1.0 m shielded cable without core

NOTE: All power cords of the above support units are non shielded (1.8m).

3.5 CONFIGURATION OF SYSTEM UNDER TEST

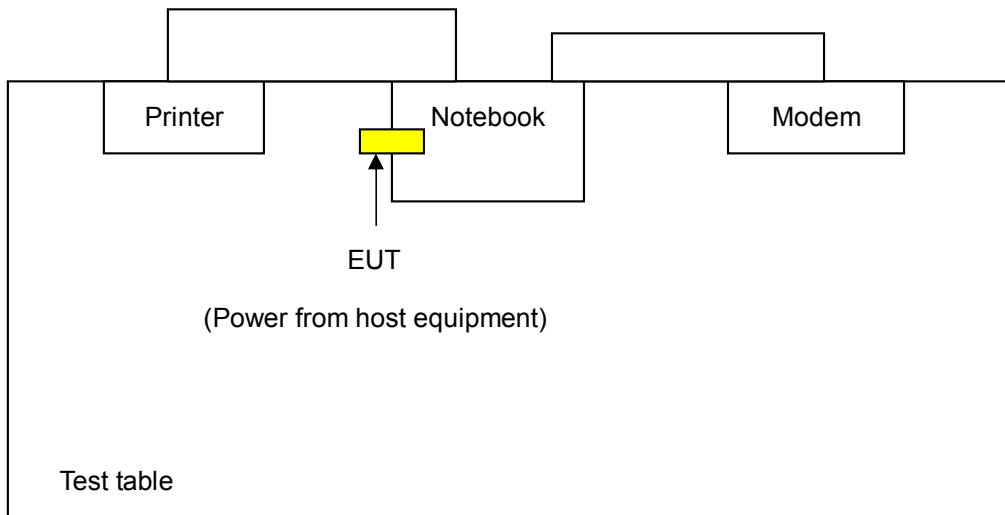

4. TEST TYPES AND RESULTS

4.1 RADIATED EMISSION MEASUREMENT

4.1.1 LIMITS OF RADIATED EMISSION MEASUREMENT

Emissions radiated outside of the specified bands, shall be according to the general radiated limits in 15.209 as following:

Frequencies (MHz)	Field strength (microvolts/meter)	Measurement distance (meters)
0.009-0.490	2400/F(kHz)	300
0.490-1.705	24000/F(kHz)	30
1.705-30.0	30	30
30-88	100	3
88-216	150	3
216-960	200	3
Above 960	500	3

NOTE:

1. The lower limit shall apply at the transition frequencies.
2. Emission level (dBuV/m) = 20 log Emission level (uV/m).
3. As shown in 15.35(b), for frequencies above 1000MHz, the field strength limits are based on average detector, however, the peak field strength of any emission shall not exceed the maximum permitted average limits, specified above by more than 20dB under any condition of modulation.

4.1.2 LIMITS OF UNWANTED EMISSION OUT OF THE RESTRICTED BANDS

Frequencies (MHz)	EIRP Limit (dBm)	Equivalent Field Strength at 3m (dBμV/m) *note 3
5150~5250	-27	68.3
5250~5350	-27	68.3
5470~5725	-27	68.3
5725~5825	-27 *note 1	68.3
	-17 *note 2	78.3

NOTE:

1. For frequencies 10MHz or greater above or below the band edge.
2. All emissions within the frequency range from the band edge to 10MHz above or below the band edge.
3. The following formula is used to convert the equipment isotropic radiated power (eirp) to field strength

$$E = \frac{1000000\sqrt{30P}}{3} \mu\text{V/m, where P is the eirp (Watts)}$$



4.1.3 TEST INSTRUMENTS

DESCRIPTION & MANUFACTURER	MODEL NO.	SERIAL NO.	CALIBRATED UNTIL
ADVANTEST Spectrum Analyzer	R3271A	85060311	July 03, 2008
HP Pre_Amplifier	8449B	3008A01922	Sep. 18, 2007
ROHDE & SCHWARZ Test Receiver	ESCS30	100375	Sep. 20, 2007
CHASE Broadband Antenna	VULB9168	138	Dec. 10, 2007
Schwarzbeck Horn_Antenna	BBHA9120	D124	Jan. 01, 2008
Schwarzbeck Horn_Antenna	BBHA 9170	BBHA9170153	Jan. 04, 2008
SCHWARZBECK Biconical Antenna	VHBA9123	459	Jun. 08, 2009
SCHWARZBECK Periodic Antenna	UPA6108	1148	Jun. 08, 2009
R&S Loop Antenna	HFH2-Z2	881058/15	Nov. 29, 2007
RF Switches (ARNITSU)	CS-201	1565157	NA
RF CABLE (Chaintek)	SF102	22054-2	Nov. 14. 2007
RF Cable(RICHTEC)	9913-30M N-N Cable	STCCAB-30M-1 GHz	Jul. 15, 2008
Software	ADT_Radiated_V 5.14	NA	NA
CHANCE MOST Antenna Tower	AT-100	0203	NA
CHANCE MOST Turn Table	TT-100	0203	NA

- Note: 1. The calibration interval of the above test instruments is 12 months (36 months for Biconical and Periodic Antenna) and the calibrations are traceable to NML/ROC and NIST/USA.
2. The horn antenna, HP preamplifier (model: 8449B) and Spectrum Analyzer (model: R3271A) are used only for the measurement of emission frequency above 1GHz if tested.
3. The test was performed in ADT Open Site No. C.
4. The FCC Site Registration No. is 656396.
5. The VCCI Site Registration No. is R-1626.
6. The CANADA Site Registration No. is IC 4824A-3.
7. Loop antenna was used for all emissions below 30 MHz.

4.1.4 TEST PROCEDURES

- a. The EUT was placed on the top of a rotating table 0.8 meters above the ground at a 3 meter semi-anechoic chamber. The table was rotated 360 degrees to determine the position of the highest radiation.
- b. The EUT was set 3 meters away from the interference-receiving antenna, which was mounted on the top of a variable-height antenna tower.
- c. The antenna is a broadband antenna, and its height is varied from one meter to four meters above the ground to determine the maximum value of the field strength. Both horizontal and vertical polarizations of the antenna are set to make the measurement.
- d. For each suspected emission, the EUT was arranged to its worst case and then the antenna was tuned to heights from 1 meter to 4 meters and the rotatable table was turned from 0 degrees to 360 degrees to find the maximum reading.
- e. The test-receiver system was set to Peak Detect Function and Specified Bandwidth with Maximum Hold Mode.
- f. If the emission level of the EUT in peak mode was 10dB lower than the limit specified, then testing could be stopped and the peak values of the EUT would be reported. Otherwise the emissions that did not have 10dB margin would be re-tested one by one using peak, quasi-peak or average method as specified and then reported in a data sheet.

NOTE:

1. The resolution bandwidth and video bandwidth of test receiver/spectrum analyzer is 120kHz for Peak detection (PK) and Quasi-peak detection (QP) at frequency below 1GHz.
2. The resolution bandwidth is 1MHz and video bandwidth of test receiver/spectrum analyzer is 3MHz for Peak detection at frequency above 1GHz.
3. The resolution bandwidth of test receiver/spectrum analyzer is 1 MHz and the video bandwidth is 10 Hz for Average detection (AV) at frequency above 1GHz.

4.1.5 DEVIATION FROM TEST STANDARD

No deviation

4.1.6 TEST SETUP

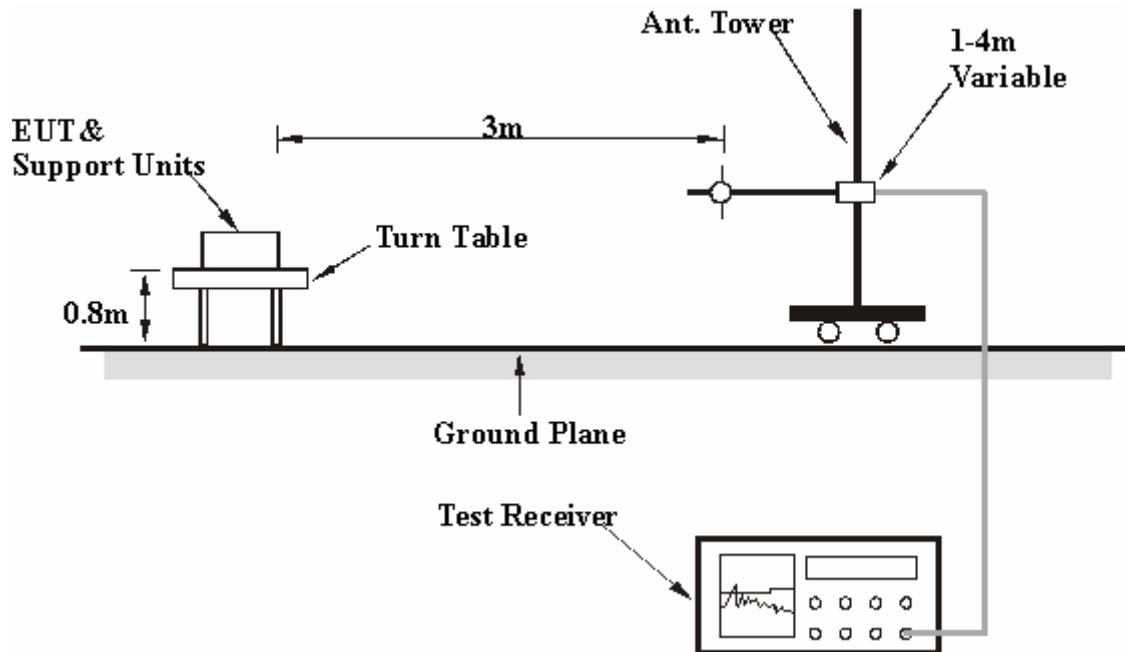

For the actual test configuration, please refer to the related item – Photographs of the Test Configuration.

4.1.7 EUT OPERATING CONDITION

- a. Placed the EUT on the testing table.
- b. Prepared another computer system to act as a communication partner and placed it outside of testing area.
- c. The communication partner run a test program “ART 53b12” to enable EUT under transmission/receiving condition continuously at specific channel frequency.



4.1.8 TEST RESULTS

Below 1GHz Worst-Case Data

MODE	Channel 9	FREQUENCY RANGE	Below 1000MHz
MODULATION TYPE	BPSK	TRANSFER RATE	6Mbps
INPUT POWER (SYSTEM)	120Vac, 60 Hz	DETECTOR FUNCTION	Quasi-Peak
ENVIRONMENTAL CONDITIONS	26deg. C, 64%RH, 972hPa	TESTED BY	Wen Yu

ANTENNA POLARITY & TEST DISTANCE: HORIZONTAL AT 3 M

No.	Freq. (MHz)	Emission Level (dBuV/m)	Limit (dBuV/m)	Margin (dB)	Antenna Height (m)	Table Angle (Degree)	Raw Value (dBuV)	Correction Factor (dB/m)
1	49.15	21.15 QP	40.00	-18.85	1.48 H	268	6.13	15.02
2	195.44	28.00 QP	43.50	-15.50	3.25 H	298	16.09	11.91
3	325.73	31.09 QP	46.00	-14.91	2.42 H	284	13.98	17.11
4	390.88	26.95 QP	46.00	-19.05	1.17 H	277	8.23	18.72
5	456.02	41.98 QP	46.00	-4.02	2.92 H	267	21.35	20.63
6	716.61	41.04 QP	46.00	-4.96	1.90 H	145	14.73	26.31

ANTENNA POLARITY & TEST DISTANCE: VERTICAL AT 3 M

No.	Freq. (MHz)	Emission Level (dBuV/m)	Limit (dBuV/m)	Margin (dB)	Antenna Height (m)	Table Angle (Degree)	Raw Value (dBuV)	Correction Factor (dB/m)
1	195.44	29.21 QP	43.50	-14.29	1.00 V	238	17.30	11.91
2	325.73	37.92 QP	46.00	-8.08	1.61 V	337	20.81	17.11
3	390.88	32.47 QP	46.00	-13.53	1.47 V	346	13.75	18.72
4	456.02	42.08 QP	46.00	-3.92	1.11 V	336	21.45	20.63
5	586.31	34.56 QP	46.00	-11.44	1.00 V	236	10.42	24.14
6	716.61	40.88 QP	46.00	-5.12	1.57 V	252	14.57	26.31

- REMARKS:**
1. Emission level(dBuV/m)=Raw Value(dBuV) + Correction Factor(dB/m)
 2. Correction Factor(dB/m) = Antenna Factor (dB/m) + Cable Factor (dB)
 3. The other emission levels were very low against the limit.
 4. Margin value = Emission level – Limit value

802.11a OFDM modulation

MODE	Channel 9	FREQUENCY RANGE	1 ~ 40 GHz
MODULATION TYPE	BPSK	TRANSFER RATE	6Mbps
INPUT POWER (SYSTEM)	120Vac, 60 Hz	DETECTOR FUNCTION	Peak(PK) Average (AV)
ENVIRONMENTAL CONDITIONS	26deg. C, 64%RH, 972hPa	TESTED BY	Sky Liao

ANTENNA POLARITY & TEST DISTANCE: HORIZONTAL AT 3 M

No.	Freq. (MHz)	Emission Level (dBuV/m)	Limit (dBuV/m)	Margin (dB)	Antenna Height (m)	Table Angle (Degree)	Raw Value (dBuV)	Correction Factor (dB/m)
1	#5460.00	63.93 PK	74.00	-10.07	1.55 H	36	27.32	36.61
2	#5460.00	46.08 AV	54.00	-7.92	1.55 H	36	9.47	36.61
3	*5500.00	110.60 PK			1.92 H	36	73.94	36.66
4	*5500.00	100.00 AV			1.92 H	36	63.34	36.66
5	#11000.00	61.30 PK	74.00	-12.70	1.65 H	40	14.65	46.65
6	#11000.00	48.20 AV	54.00	-5.80	1.65 H	40	1.55	46.65
7	16500.00	68.50 PK	88.30	-19.80	1.10 H	1	20.23	48.27
8	16500.00	53.60 AV	68.30	-14.70	1.10 H	1	5.33	48.27

ANTENNA POLARITY & TEST DISTANCE: VERTICAL AT 3 M

No.	Freq. (MHz)	Emission Level (dBuV/m)	Limit (dBuV/m)	Margin (dB)	Antenna Height (m)	Table Angle (Degree)	Raw Value (dBuV)	Correction Factor (dB/m)
1	#5460.00	61.89 PK	74.00	-12.11	1.36 V	106	25.28	36.61
2	#5460.00	45.25 AV	54.00	-8.75	1.36 V	106	8.64	36.61
3	*5500.00	107.00 PK			1.35 V	110	70.34	36.66
4	*5500.00	95.80 AV			1.35 V	110	59.14	36.66
5	#11000.00	65.70 PK	74.00	-8.30	1.50 V	10	19.05	46.65
6	#11000.00	51.30 AV	54.00	-2.70	1.50 V	10	4.65	46.65
7	16500.00	73.08 PK	88.30	-15.22	1.17 V	7	24.81	48.27
8	16500.00	57.80 AV	68.30	-10.50	1.17 V	7	9.53	48.27

- NOTE:**
1. Emission level(dBuV/m)=Raw Value(dBuV) + Correction Factor(dB/m)
 2. Correction Factor(dB/m) = Antenna Factor (dB/m) + Cable Factor (dB)
 3. The other emission levels were very low against the limit.
 4. Margin value = Emission level – Limit value
 5. "*" : Fundamental frequency
 6. "#"The radiated frequency falling in the restricted band.

MODE	Channel 14	FREQUENCY RANGE	1 ~ 40 GHz
MODULATION TYPE	BPSK	TRANSFER RATE	6Mbps
INPUT POWER (SYSTEM)	120Vac, 60 Hz	DETECTOR FUNCTION	Peak(PK) Average (AV)
ENVIRONMENTAL CONDITIONS	26deg. C, 64%RH, 972hPa	TESTED BY	Sky Liao

ANTENNA POLARITY & TEST DISTANCE: HORIZONTAL AT 3 M

No.	Freq. (MHz)	Emission Level (dBuV/m)	Limit (dBuV/m)	Margin (dB)	Antenna Height (m)	Table Angle (Degree)	Raw Value (dBuV)	Correction Factor (dB/m)
1	*5600.00	108.50 PK			1.55 H	50	71.60	36.90
2	*5600.00	97.20 AV			1.55 H	50	60.30	36.90
3	#11200.00	61.20 PK	74.00	-12.80	1.72 H	325	14.40	46.80
4	#11200.00	47.10 AV	54.00	-6.90	1.72 H	325	0.30	46.80
5	16800.00	72.10 PK	88.30	-16.20	1.24 H	358	22.61	49.49
6	16800.00	57.50 AV	68.30	-10.80	1.24 H	358	8.01	49.49

ANTENNA POLARITY & TEST DISTANCE: VERTICAL AT 3 M

No.	Freq. (MHz)	Emission Level (dBuV/m)	Limit (dBuV/m)	Margin (dB)	Antenna Height (m)	Table Angle (Degree)	Raw Value (dBuV)	Correction Factor (dB/m)
1	*5600.00	105.50 PK			1.07 V	180	68.60	36.90
2	*5600.00	94.10 AV			1.07 V	180	57.20	36.90
3	#11200.00	66.00 PK	74.00	-8.00	1.56 V	3	19.20	46.80
4	#11200.00	51.40 AV	54.00	-2.60	1.56 V	3	4.60	46.80
5	16800.00	72.20 PK	88.30	-16.10	1.05 V	6	22.71	49.49
6	16800.00	58.10 AV	68.30	-10.20	1.05 V	6	8.61	49.49

- NOTE:**
1. Emission level(dBuV/m)=Raw Value(dBuV) + Correction Factor(dB/m)
 2. Correction Factor(dB/m) = Antenna Factor (dB/m) + Cable Factor (dB)
 3. The other emission levels were very low against the limit.
 4. Margin value = Emission level – Limit value
 5. "*" : Fundamental frequency
 6. "#"The radiated frequency falling in the restricted band.



MODE	Channel 19	FREQUENCY RANGE	1 ~ 40 GHz
MODULATION TYPE	BPSK	TRANSFER RATE	6Mbps
INPUT POWER (SYSTEM)	120Vac, 60 Hz	DETECTOR FUNCTION	Peak(PK) Average (AV)
ENVIRONMENTAL CONDITIONS	26deg. C, 64%RH, 972hPa	TESTED BY	Sky Liao

ANTENNA POLARITY & TEST DISTANCE: HORIZONTAL AT 3 M

No.	Freq. (MHz)	Emission Level (dBuV/m)	Limit (dBuV/m)	Margin (dB)	Antenna Height (m)	Table Angle (Degree)	Raw Value (dBuV)	Correction Factor (dB/m)
1	*5700.00	108.70 PK			1.48 H	270	71.55	37.15
2	*5700.00	96.80 AV			1.48 H	270	59.65	37.15
3	5725.00	81.40 PK	88.30	-6.90	1.65 H	85	44.19	37.21
4	5725.00	63.00 AV	68.30	-5.30	1.65 H	85	25.79	37.21
5	#11400.00	60.10 PK	74.00	-13.90	1.53 H	337	13.15	46.95
6	#11400.00	46.90 AV	54.00	-7.10	1.53 H	337	-0.05	46.95
7	17100.00	74.00 PK	88.30	-14.30	1.15 H	358	23.36	50.64
8	17100.00	60.20 AV	68.30	-8.10	1.15 H	358	9.56	50.64

ANTENNA POLARITY & TEST DISTANCE: VERTICAL AT 3 M

No.	Freq. (MHz)	Emission Level (dBuV/m)	Limit (dBuV/m)	Margin (dB)	Antenna Height (m)	Table Angle (Degree)	Raw Value (dBuV)	Correction Factor (dB/m)
1	*5700.00	106.30 PK			1.05 V	210	69.15	37.15
2	*5700.00	94.60 AV			1.05 V	210	57.45	37.15
3	5725.00	78.60 PK	88.30	-9.70	1.55 V	110	41.39	37.21
4	5725.00	60.00 AV	68.30	-8.30	1.55 V	110	22.79	37.21
5	#11400.00	66.60 PK	74.00	-7.40	1.50 V	63	19.65	46.95
6	#11400.00	51.90 AV	54.00	-2.10	1.50 V	63	4.95	46.95
7	17100.00	73.90 PK	88.30	-14.40	1.15 V	1	23.26	50.64
8	17100.00	60.00 AV	68.30	-8.30	1.15 V	1	9.36	50.64

- NOTE:**
1. Emission level(dBuV/m)=Raw Value(dBuV) + Correction Factor(dB/m)
 2. Correction Factor(dB/m) = Antenna Factor (dB/m) + Cable Factor (dB)
 3. The other emission levels were very low against the limit.
 4. Margin value = Emission level – Limit value
 5. "*" : Fundamental frequency
 6. "#" The radiated frequency falling in the restricted band.

RESTRICTED BANDEDGE (802.11a MODE, CH9, HORIZONTAL)

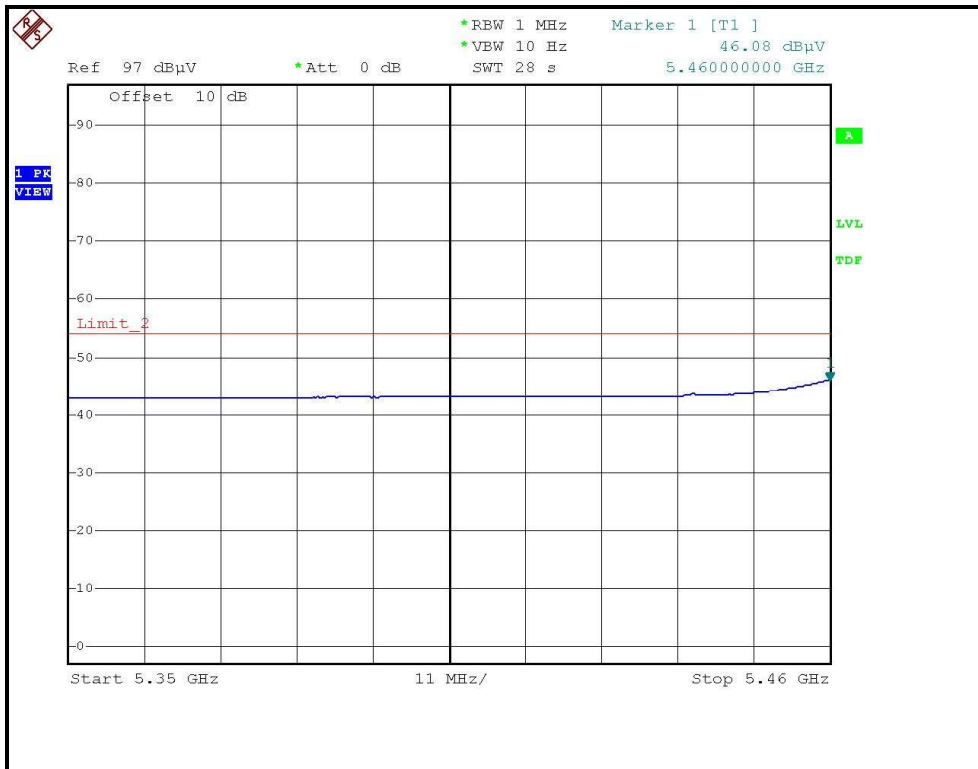
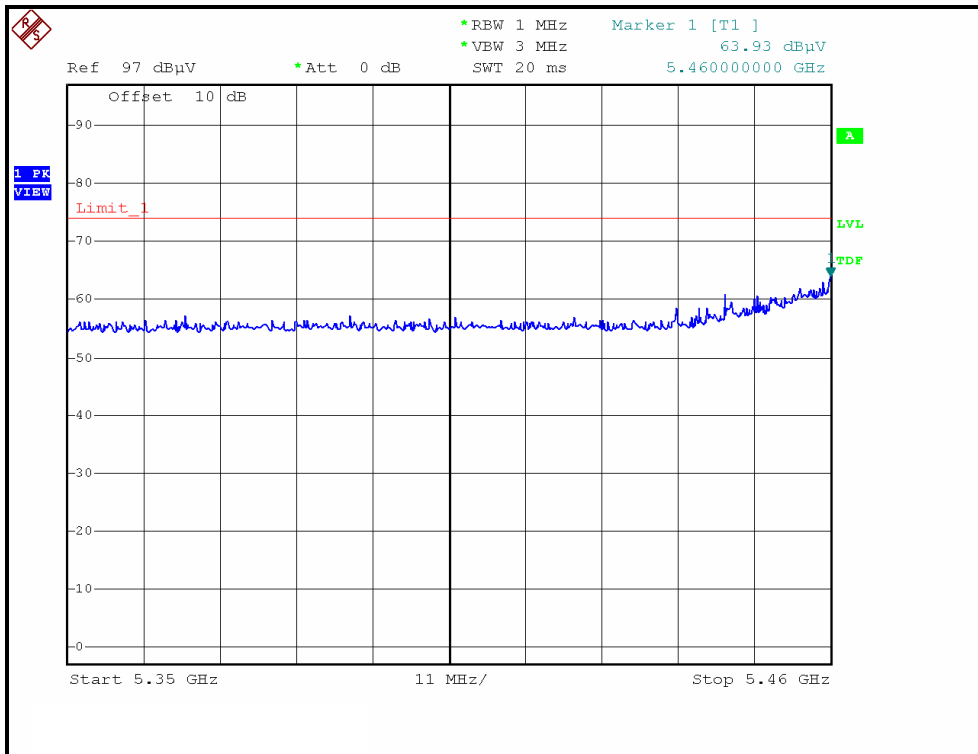

RESTRICTED BANDEDGE (802.11a MODE, CH9, VERTICAL)

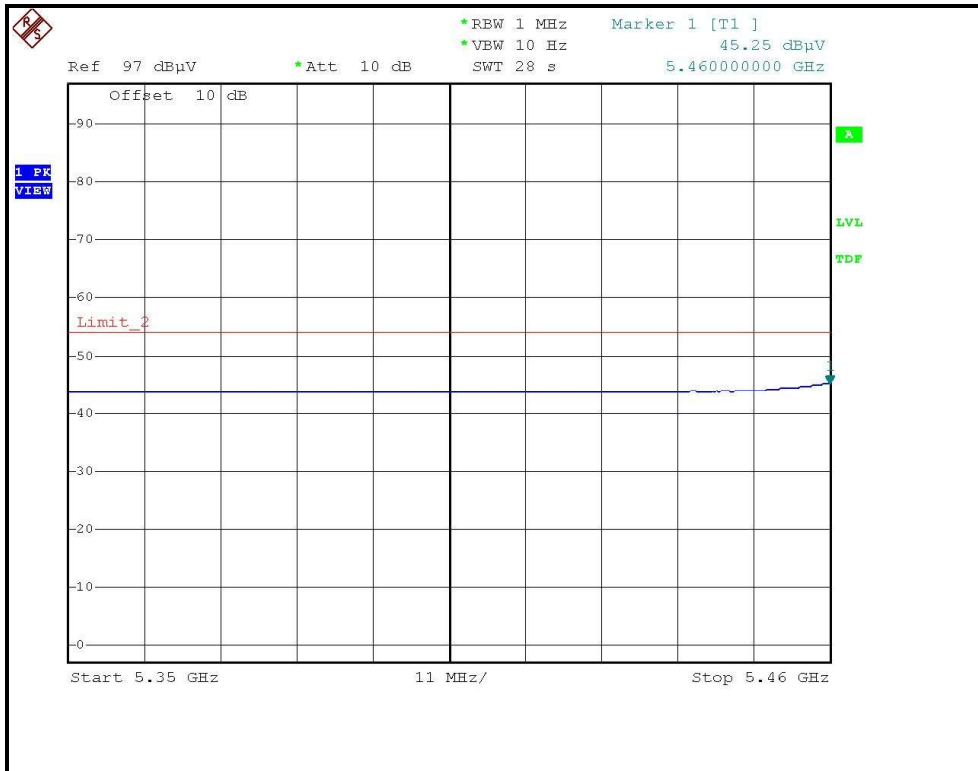
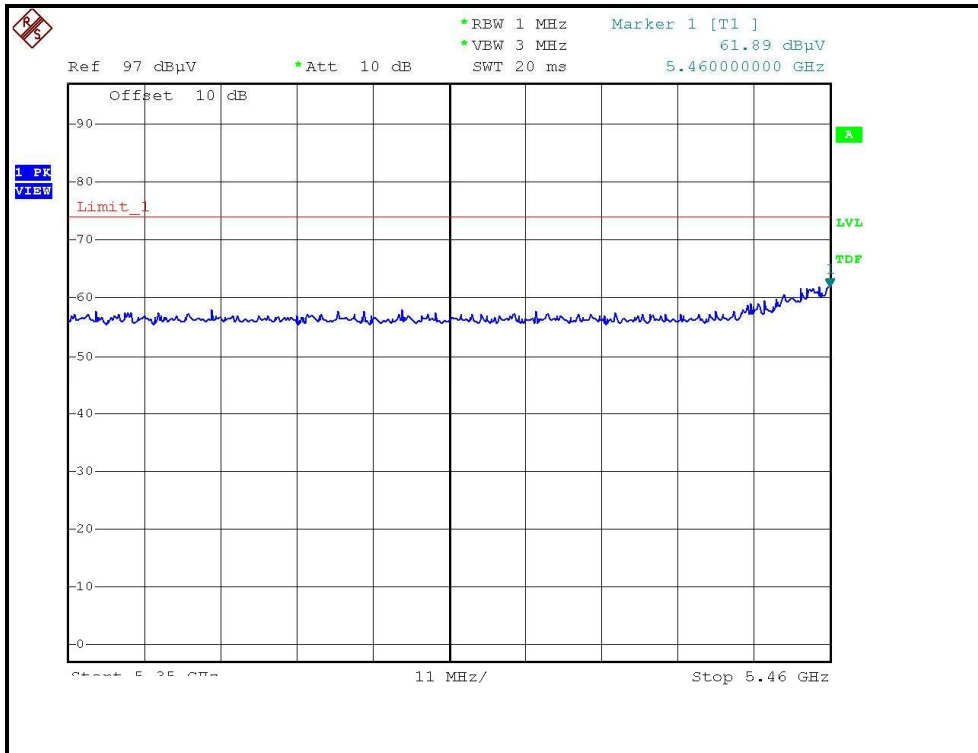

4.2 PEAK TRANSMIT POWER MEASUREMENT

4.2.1 LIMITS OF PEAK TRANSMIT POWER MEASUREMENT

Frequency Band	Limit
5.15 – 5.25GHz	The lesser of 50mW (17dBm) or 4dBm + 10logB
5.25 – 5.35GHz	The lesser of 250mW (24dBm) or 11dBm + 10logB
5.47 – 5.725GHz	The lesser of 250mW (24dBm) or 11dBm + 10logB
5.725 – 5.825GHz	The lesser of 1W (30dBm) or 17dBm + 10logB

NOTE: Where B is the 26dB emission bandwidth in MHz.

4.2.2 TEST INSTRUMENTS

Description & Manufacturer	Model No.	Serial No.	Calibrated Until
ADVANTEST SPECTRUM ANALYZER	U3772	160100280	April 10.2008

NOTE:

- 1.The measurement uncertainty is less than +/- 2.6dB, which is calculated as per the NAMAS document NIS81. This uncertainty represents an expanded uncertainty expressed at approximately the 95% confidence level using a coverage factor of k=2.
- 2.The calibration interval of the above test instruments is 12 months and the calibrations are traceable to NML/ROC and NIST/USA.

4.2.3 TEST PROCEDURE

1. The transmitter output was connected to the spectrum analyzer.
2. Set span to encompass the entire emission bandwidth of the signal.
3. Set RBW to 1MHz, VBW to 300kHz.
4. Using the spectrum analyzer's channel power measurement function to measure the output power.

NOTE:

The test is performed in accordance with FCC Public Notice: APPENDIX A Guidelines for Assessing Unlicensed National Information Infrastructure (U-NII) Devices – Part 15, Subpart E, August 2002.

The transmitter output operates continuously therefore Method # 1 is used.

4.2.4 DEVIATION FROM TEST STANDARD

No deviation

4.2.5 TEST SETUP

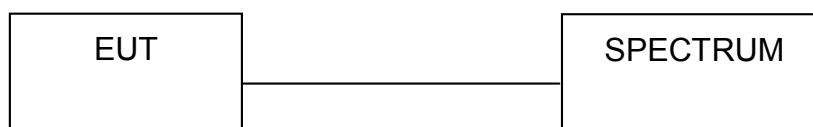

4.2.6 EUT OPERATING CONDITIONS

The software provided by client to enable the EUT under transmission condition continuously at specific channel frequencies individually.

4.2.7 TEST RESULTS

802.11a OFDM modulation

MODULATION TYPE	BPSK	TRANSFER RATE	6Mbps
INPUT POWER (SYSTEM)	120Vac, 60 Hz	ENVIRONMENTAL CONDITIONS	26deg.C, 68%RH, 972hPa
TESTED BY	Rex Huang		

CHANNEL	CHANNEL FREQUENCY (MHz)	PEAK POWER OUTPUT (dBm)	PEAK POWER OUTPUT (mW)	PEAK POWER LIMIT (dBm)	26dBc Occupied Bandwidth (MHz)	PASS/FAIL
9	5500	16.19	41.591	13	39.75	PASS
14	5600	16.38	43.451	13	42.35	PASS
19	5700	16.62	45.920	13	40.10	PASS

NOTE: The 26dBc Occupied Bandwidth plot, please refer to the following pages.

Peak Power Output:

CH9



CH14



CH19

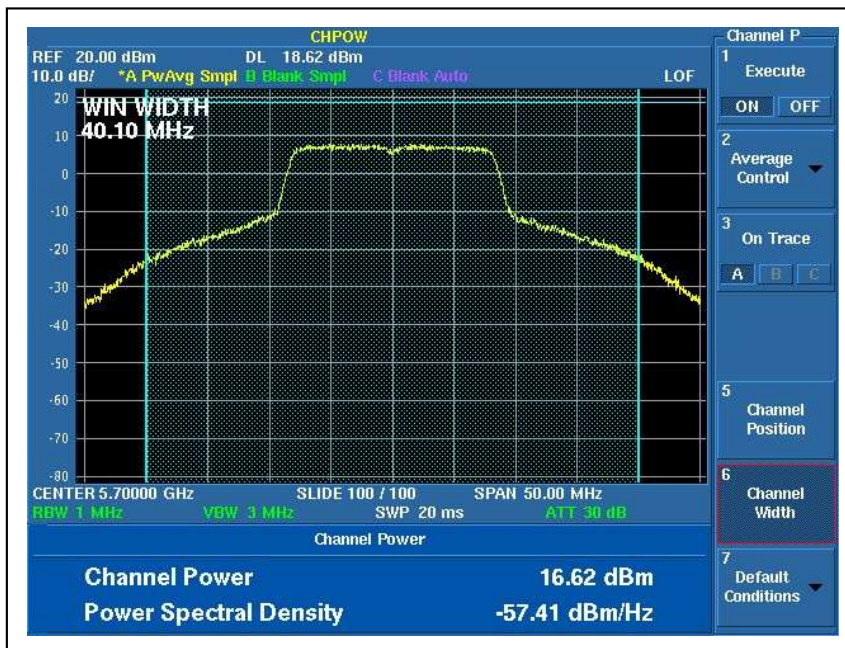

26dB Occupied Bandwidth:
CH9

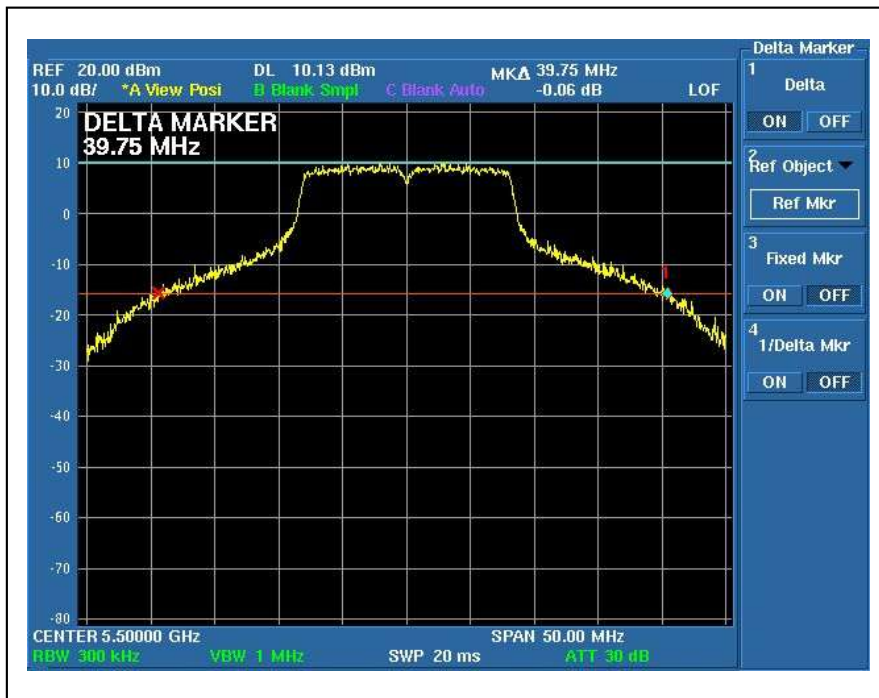

CH14

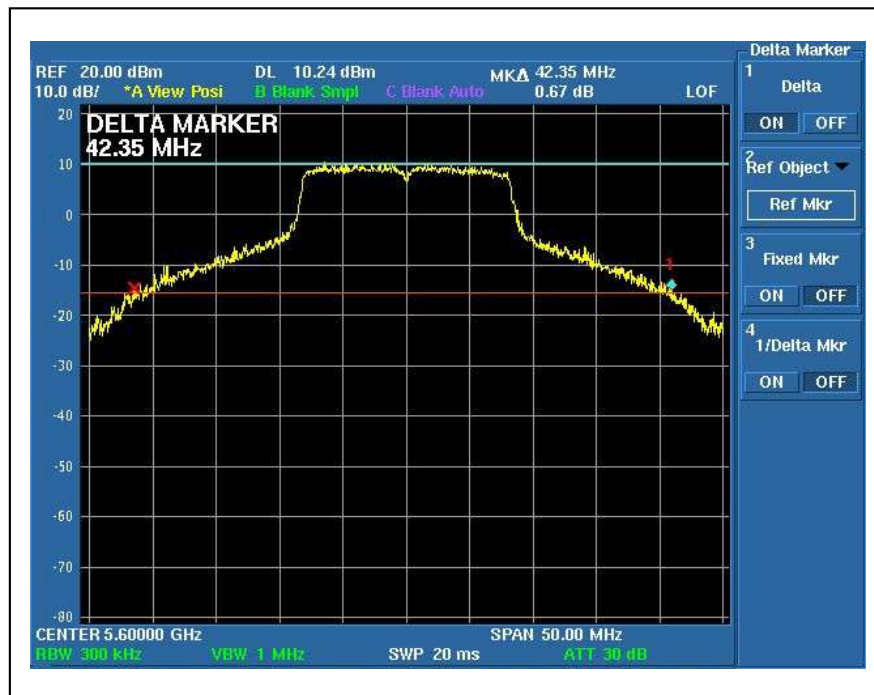

CH19

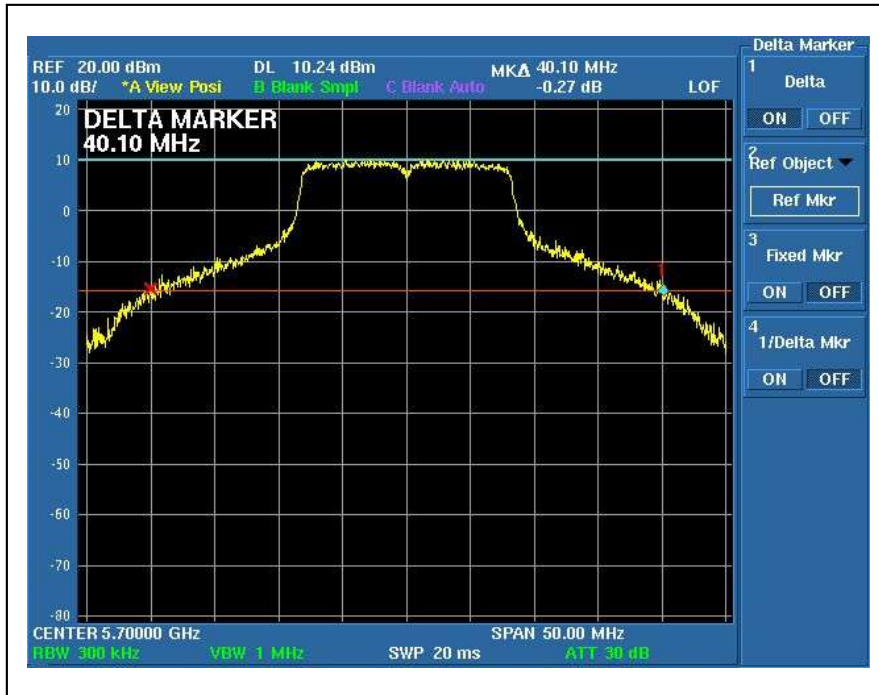

4.3 PEAK POWER EXCURSION MEASUREMENT

4.3.1 LIMITS OF PEAK POWER EXCURSION MEASUREMENT

Frequency Band	Limit
5.15 – 5.25 GHz	13dB
5.25 – 5.35 GHz	13dB
5.47 – 5.725 GHz	13dB
5.725 – 5.825 GHz	13dB

4.3.2 TEST INSTRUMENTS

Description & Manufacturer	Model No.	Serial No.	Calibrated Until
ADVANTEST SPECTRUM ANALYZER	U3772	160100280	April 10.2008

NOTE:

- 1.The measurement uncertainty is less than +/- 2.6dB, which is calculated as per the NAMAS document NIS81. This uncertainty represents an expanded uncertainty expressed at approximately the 95% confidence level using a coverage factor of k=2.
- 2.The calibration interval of the above test instruments is 12 months and the calibrations are traceable to NML/ROC and NIST/USA.

4.3.3 TEST PROCEDURE

1. The transmitter output was connected to the spectrum analyzer.
2. Set the spectrum bandwidth span to view the entire spectrum.
3. Using peak detector and Max-hold function for Trace 1 (RB=1MHz, VB=3MHz) and 2 (RB=1MHz, VB=300KHz).
4. The largest difference between Trace 1 and Trace 2 in any 1MHz band on any frequency was recorded.

4.3.4 DEVIATION FROM TEST STANDARD

No deviation

4.3.5 TEST SETUP

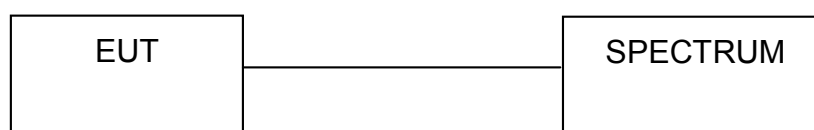

4.3.6 EUT OPERATING CONDITIONS

The software provided by client to enable the EUT under transmission condition continuously at specific channel frequencies individually.

CH14

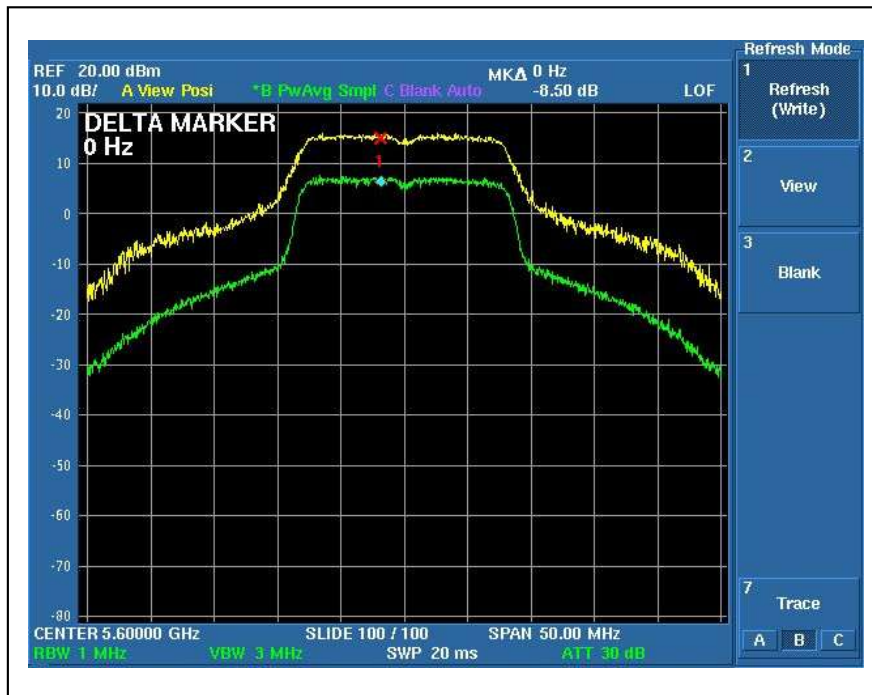

CH19

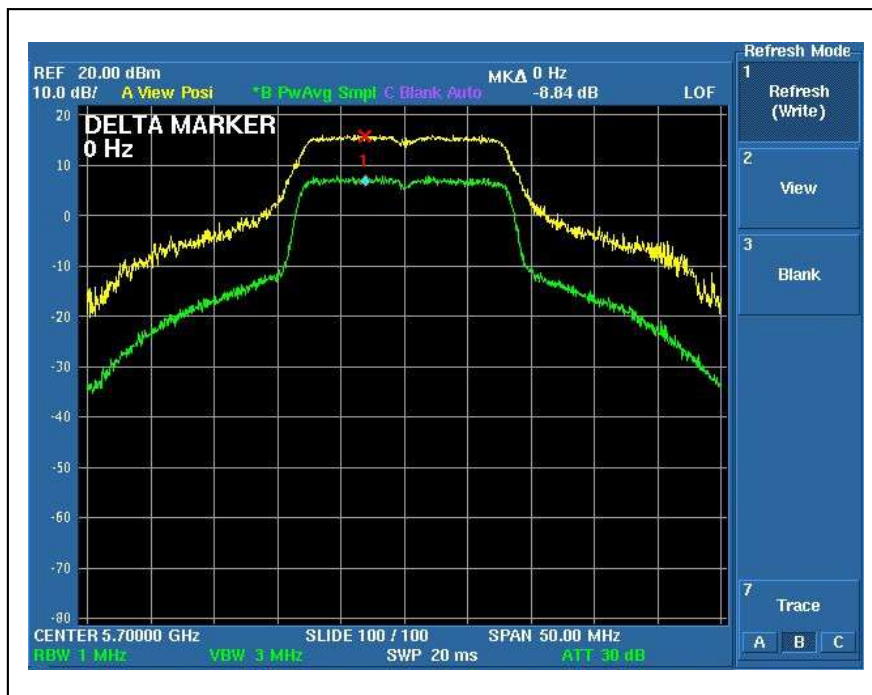

4.4 PEAK POWER SPECTRAL DENSITY MEASUREMENT

4.4.1 LIMITS OF PEAK POWER SPECTRAL DENSITY MEASUREMENT

Frequency Band	Limit
5.15 ~ 5.25GHz	4dBm
5.25 ~ 5.35GHz	11dBm
5.47 ~ 5.725GHz	11dBm
5.725 ~ 5.825GHz	17dBm

4.4.2 TEST INSTRUMENTS

Description & Manufacturer	Model No.	Serial No.	Calibrated Until
ADVANTEST SPECTRUM ANALYZER	U3772	160100280	April 10.2008

NOTE:

- 1.The measurement uncertainty is less than +/- 2.6dB, which is calculated as per the NAMAS document NIS81. This uncertainty represents an expanded uncertainty expressed at approximately the 95% confidence level using a coverage factor of k=2.
- 2.The calibration interval of the above test instruments is 12 months and the calibrations are traceable to NML/ROC and NIST/USA.

4.4.3 TEST PROCEDURES

1. The transmitter output was connected to the spectrum analyzer.
2. Set RBW=1MHz, VBW=3MHz. The PPSD is the highest level found across the emission in any 1MHz band.

4.4.4 DEVIATION FROM TEST STANDARD

No deviation

4.4.5 TEST SETUP



4.4.6 EUT OPERATING CONDITIONS

Same as 4.3.6

4.4.7 TEST RESULTS

802.11a OFDM modulation

MODULATION TYPE	BPSK	TRANSFER RATE	6Mbps
INPUT POWER (SYSTEM)	120Vac, 60 Hz	ENVIRONMENTAL CONDITIONS	26deg.C, 68%RH, 972hPa
TESTED BY	Rex Huang		

CHANNEL	CHANNEL FREQUENCY (MHz)	RF POWER LEVEL IN 1MHz BW (dBm)	MAXIMUM LIMIT (dBm)	PASS/FAIL
9	5500	7.48	11	PASS
14	5600	7.58	11	PASS
19	5700	7.59	11	PASS

CH9

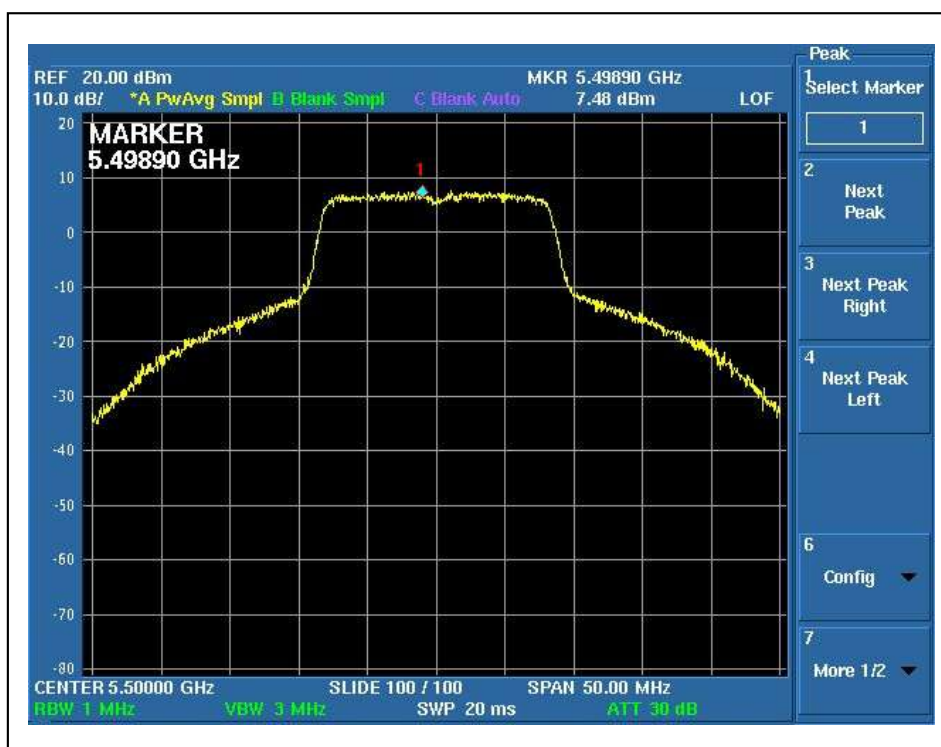

CH14

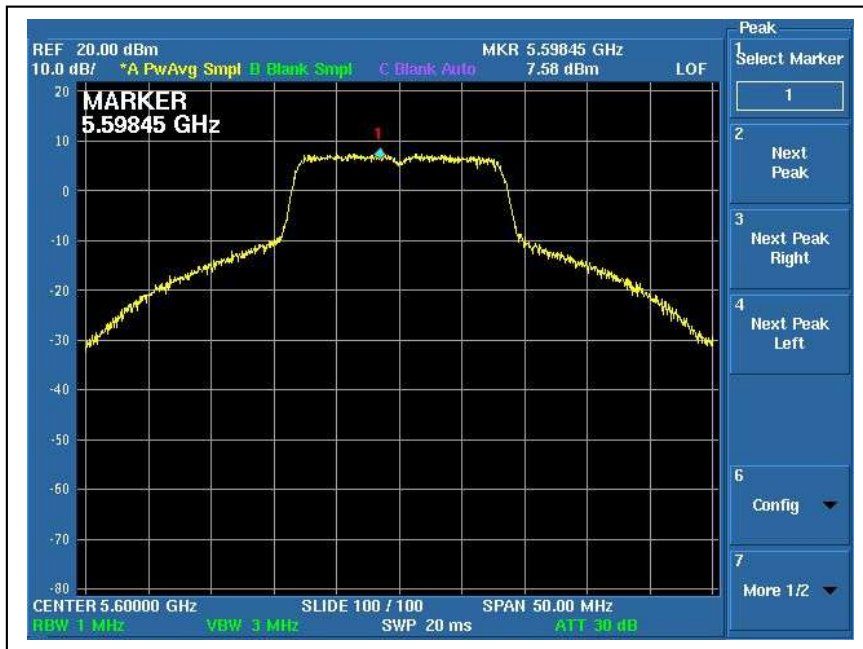

CH19

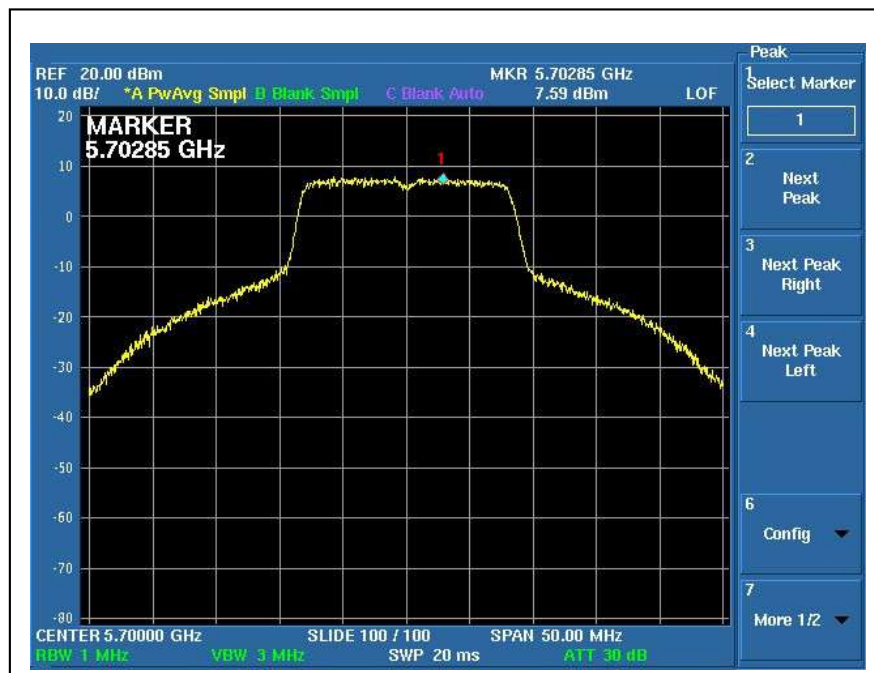

4.5 BAND EDGES MEASUREMENT

4.5.1 TEST INSTRUMENTS

Description & Manufacturer	Model No.	Serial No.	Calibrated Until
R&S SPECTRUM ANALYZER	FSP40	100037	Aug. 15, 2008

NOTE:

1.The measurement uncertainty is less than +/- 2.6dB, which is calculated as per the NAMAS document NIS81. This uncertainty represents an expanded uncertainty expressed at approximately the 95% confidence level using a coverage factor of k=2.

2.The calibration interval of the above test instruments is 12 months and the calibrations are traceable to NML/ROC and NIST/USA.

4.5.2 TEST PROCEDURE

The transmitter output was connected to the spectrum analyzer via a low loss cable. Set both RBW and VBW of spectrum analyzer to 1MHz with suitable frequency span including 100 MHz bandwidth from band edge. The band edges was measured and recorded.

4.5.3 EUT OPERATING CONDITION

The software provided by client to enable the EUT under transmission condition continuously at specific channel frequencies individually.

4.5.4 TEST RESULTS

For signals in the restricted bands above and below the 5.47 to 5.725GHz allocated band a measurement was made of the amplitude of the spurious emissions with respect to the intentional signals. The relative amplitude, in dBc, was applied to the average and peak field strength of the intentional signal made on the OATS to calculate the field strength of the unintentional signals.

The spectrum plots (Peak RBW=1MHz, VBW=3MHz; Average RBW=1MHz, VBW=10Hz) are attached on the following pages.

802.11a OFDM modulation (CH 19: 5700MHz)

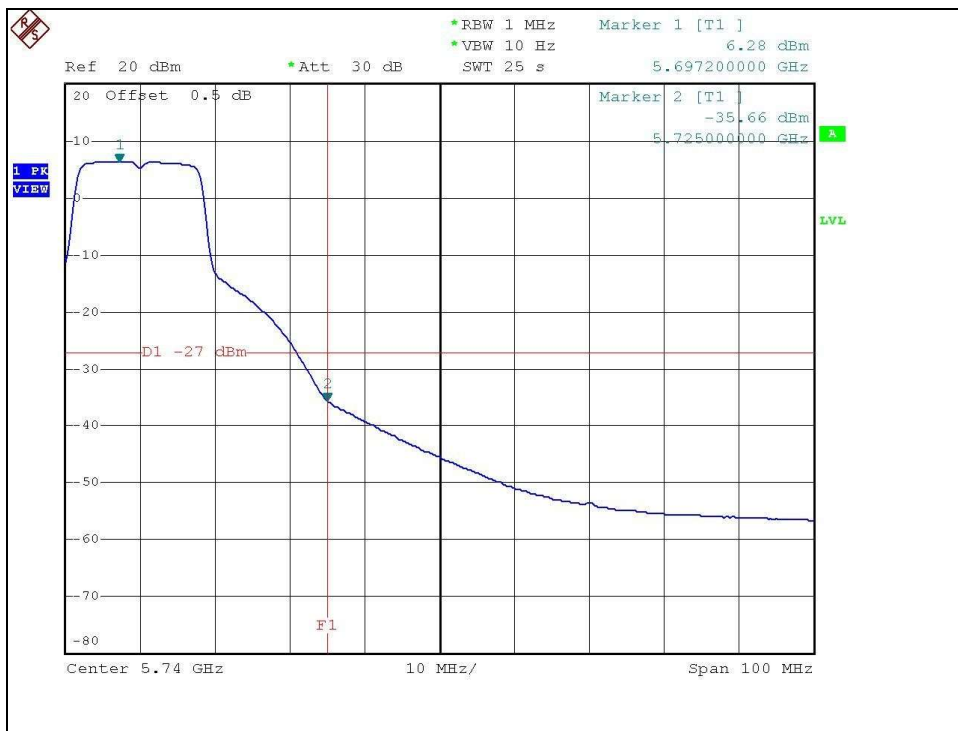
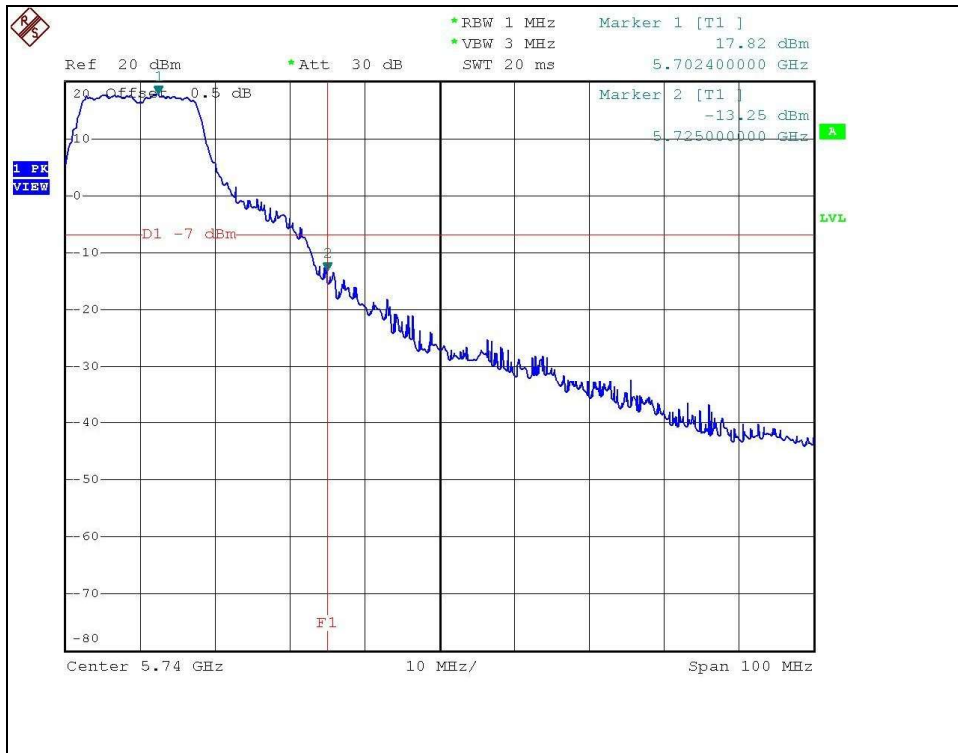

802.11a 10th conducted Harmonic

CH 9

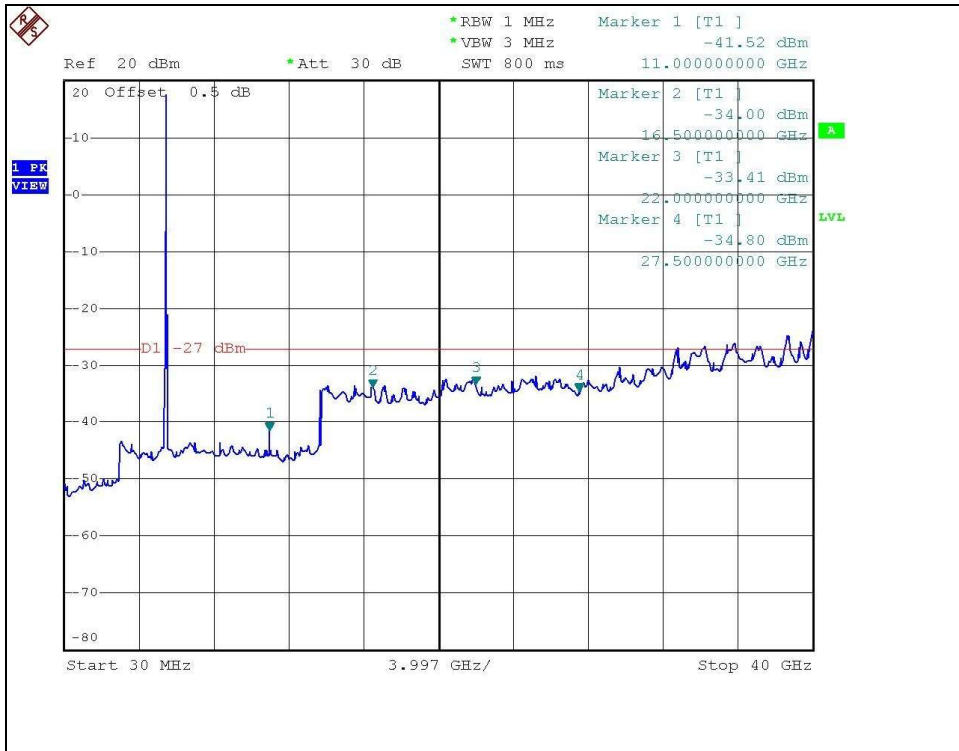

CH 19

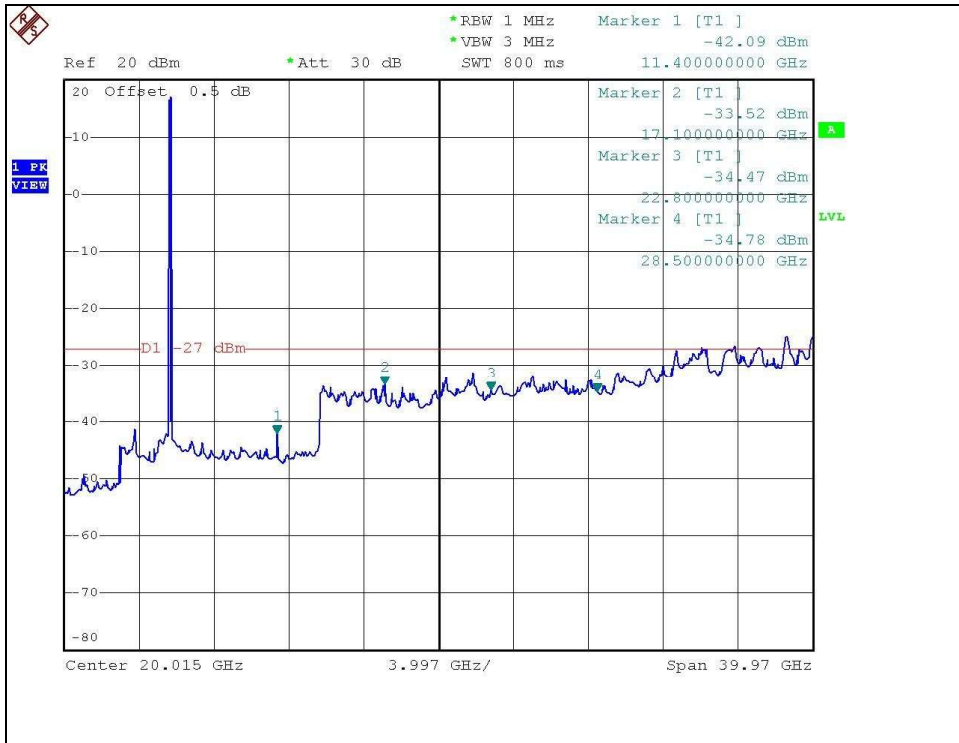

4.6 ANTENNA REQUIREMENT

4.6.1 STANDARD APPLICABLE

For intentional device, according to FCC 47 CFR Section 15.203, an intentional radiator shall be designed to ensure that no antenna other than that furnished by the responsible party shall be used with the device.

And according to FCC 47 CFR Section 15.407(a), if transmitting antennas of directional gain greater than 6dBi are used, the power shall be reduced by the amount in dB that the directional gain of the antenna exceeds 6dBi.

4.6.2 ANTENNA CONNECTED CONSTRUCTION

The antenna used in this product is Printed antenna without connector. The maximum Gain of the antenna is 0dBi.



5. INFORMATION ON THE TESTING LABORATORIES

We, ADT Corp., were founded in 1988 to provide our best service in EMC, Radio, Telecom and Safety consultation. Our laboratories are accredited and approved by the following approval agencies according to ISO/IEC 17025:

USA	FCC, UL, A2LA
Germany	TUV Rheinland
Japan	VCCI
Norway	NEMKO
Canada	INDUSTRY CANADA , CSA
R.O.C.	TAF, BSMI, NCC
Netherlands	Telefication
Singapore	PSB , GOST-ASIA(MOU)
Russia	CERTIS(MOU)

Copies of accreditation certificates of our laboratories obtained from approval agencies can be downloaded from our web site:

www.adt.com.tw/index.5/phtml. If you have any comments, please feel free to contact us at the following:

Linko EMC/RF Lab:

Tel: 886-2-26052180

Fax: 886-2-26052943

Hsin Chu EMC/RF Lab:

Tel: 886-3-5935343

Fax: 886-3-5935342

Hwa Ya EMC/RF/Safety Telecom Lab:

Tel: 886-3-3183232

Fax: 886-3-3185050

Web Site: www.adt.com.tw

The address and road map of all our labs can be found in our web site also

6. APPENDIX-A - MODIFICATIONS RECORDERS FOR ENGINEERING CHANGES TO THE EUT BY THE LAB

No any modifications are made to the EUT by the lab during the test.