



FCC TEST REPORT (15.407)

REPORT NO.: RF940414L13
MODEL NO.: SL-3050
(refer to page 7 for other models)
RECEIVED: Apr. 27, 2005
TESTED: Apr. 27 ~ May 07, 2005
ISSUED: May 12, 2005

APPLICANT: 3Com Corporation

ADDRESS: 350 Campus Drive, Marlborough, MA
10752-3064. U.S.A.

ISSUED BY: Advance Data Technology Corporation

LAB ADDRESS: No. 47, 14th Ling, Chia Pau Tsuen, Lin Kou
Hsiang 244, Taipei Hsien, Taiwan, R.O.C.

TEST LOCATION: No. 19, Hwa Ya 2nd Rd., Wen Hwa Tsuen,
Kwei Shan Hsiang, Taoyuan Hsien 333,
Taiwan, R.O.C.

This test report consists of 76 pages in total. It may be duplicated completely for legal use with the approval of the applicant. It should not be reproduced except in full, without the written approval of our laboratory. The client should not use it to claim product endorsement by CNLA, A2LA or any government agencies. The test results in the report only apply to the tested sample.



0528
ILAC MRA



No. 2177-01



Table of Contents

1.	CERTIFICATION	4
2.	SUMMARY OF TEST RESULTS	5
2.1	MEASUREMENT UNCERTAINTY	6
3.	GENERAL INFORMATION.....	7
3.1	GENERAL DESCRIPTION OF EUT	7
3.2	DESCRIPTION OF TEST MODES.....	9
3.2.1	CONFIGURATION OF SYSTEM UNDER TEST	10
3.2.2	TEST MODE APPLICABILITY AND TESTED CHANNEL DETAIL:.....	11
3.3	GENERAL DESCRIPTION OF APPLIED STANDARDS	13
3.4	DESCRIPTION OF SUPPORT UNITS	14
4.	TEST TYPES AND RESULTS (5150 ~ 5350MHz BAND)	15
4.1	CONDUCTED EMISSION MEASUREMENT	15
4.1.1	LIMITS OF CONDUCTED EMISSION MEASUREMENT.....	15
4.1.2	TEST INSTRUMENTS.....	15
4.1.3	TEST PROCEDURES	16
4.1.4	DEVIATION FROM TEST STANDARD	16
4.1.5	TEST SETUP	17
4.1.6	EUT OPERATING CONDITIONS	17
4.1.7	TEST RESULTS	18
4.2	RADIATED EMISSION MEASUREMENT	20
4.2.1	LIMITS OF RADIATED EMISSION MEASUREMENT.....	20
4.2.2	LIMITS OF UNWANTED EMISSION OUT OF THE RESTRICTED BANDS.....	21
4.2.3	TEST INSTRUMENTS.....	22
4.2.4	TEST PROCEDURES	23
4.2.5	DEVIATION FROM TEST STANDARD	23
4.2.6	TEST SETUP	24
4.2.7	EUT OPERATING CONDITION	24
4.2.8	TEST RESULTS	25
4.3	PEAK TRANSMIT POWER MEASUREMENT	33
4.3.1	LIMITS OF PEAK TRANSMIT POWER MEASUREMENT.....	33
4.3.2	TEST INSTRUMENTS.....	33
4.3.3	TEST PROCEDURE.....	34
4.3.4	DEVIATION FROM TEST STANDARD	34
4.3.5	TEST SETUP	34
4.3.6	EUT OPERATING CONDITIONS	34
4.3.7	TEST RESULTS	35
4.4	PEAK POWER EXCURSION MEASUREMENT	45
4.4.1	LIMITS OF PEAK POWER EXCURSION MEASUREMENT.....	45



4.4.2	TEST INSTRUMENTS.....	45
4.4.3	TEST PROCEDURE.....	46
4.4.4	DEVIATION FROM TEST STANDARD	46
4.4.5	TEST SETUP	46
4.4.6	EUT OPERATING CONDITIONS	46
4.4.7	TEST RESULTS	47
4.5	PEAK POWER SPECTRAL DENSITY MEASUREMENT	53
4.5.1	LIMITS OF PEAK POWER SPECTRAL DENSITY MEASUREMENT.....	53
4.5.2	TEST INSTRUMENTS.....	53
4.5.3	TEST PROCEDURES	54
4.5.4	DEVIATION FROM TEST STANDARD	54
4.5.5	TEST SETUP	54
4.5.6	EUT OPERATING CONDITIONS	54
4.5.7	TEST RESULTS	55
4.6	FREQUENCY STABILITY	61
4.6.1	LIMITS OF FREQUENCY STABILITY MEASUREMENT	61
4.6.2	TEST INSTRUMENTS.....	61
4.6.3	TEST PROCEDURE.....	61
4.6.4	DEVIATION FROM TEST STANDARD	61
4.6.5	TEST SETUP	62
4.6.6	EUT OPERATING CONDITION	62
4.6.7	TEST RESULTS	63
4.7	BAND EDGES MEASUREMENT	64
4.7.1	TEST INSTRUMENTS.....	64
4.7.2	TEST PROCEDURE.....	64
4.7.3	EUT OPERATING CONDITION	64
4.7.4	TEST RESULTS	64
4.8	ANTENNA REQUIREMENT	73
4.8.1	STANDARD APPLICABLE	73
4.8.2	ANTENNA CONNECTED CONSTRUCTION	73
5.	PHOTOGRAPHS OF THE TEST CONFIGURATION.....	74
6.	INFORMATION ON THE TESTING LABORATORIES	76



1. CERTIFICATION

PRODUCT: 11a/b/g Wireless PC Card with XJACK Antenna
BRAND NAME: 3Com
MODEL NO.: SL-3050
(refer to page 7 for other models)
APPLICANT: 3Com Corporation
TEST SAMPLE: ENGINEERING SAMPLE
TESTED: Apr. 27 ~ May 07, 2005
STANDARDS: FCC Part 15, Subpart E (Section 15.407)
ANSI C63.4-2003

The above equipment has been tested by **Advance Data Technology Corporation**, and found compliance with the requirement of the above standards. The test record, data evaluation & Equipment Under Test (EUT) configurations represented herein are true and accurate accounts of the measurements of the sample's EMC characteristics under the conditions specified in this report.

PREPARED BY :  for _____, **DATE:** May 12, 2005
(Candice Chen)

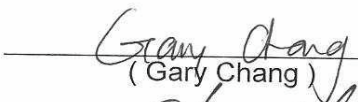
TECHNICAL ACCEPTANCE :  _____, **DATE:** May 12, 2005
Responsible for RF (Gary Chang)

APPROVED BY :  _____, **DATE:** May 12, 2005
(Cody Chang, Deputy Manager)



2. SUMMARY OF TEST RESULTS

The EUT has been tested according to the following specifications:

APPLIED STANDARD: FCC Part 15, Subpart E (Section 15.407)			
Standard Section	Test Type	Result	Remark
15.407(b)(5)	AC Power Conducted Emission	PASS	Meet the requirement of limit. Minimum passing margin is -17.42dB at 0.205MHz
15.407(b/1/2/3) (b)(5)	Electric Field Strength Spurious Emissions, 30MHz ~ 40000MHz	PASS	Meet the requirement of limit. Minimum passing margin is -5.52dB at 702.59MHz
15.407(a/1/2/3)	Peak Transmit Power	PASS	Meet the requirement of limit.
15.407(a)(6)	Peak Power Excursion	PASS	Meet the requirement of limit.
15.407(a/1/2/3)	Peak Power Spectral Density	PASS	Meet the requirement of limit.
15.407(g)	Frequency Stability	PASS	Meet the requirement of limit.

2.1 MEASUREMENT UNCERTAINTY

Where relevant, the following measurement uncertainty levels have been estimated for tests performed on the EUT as specified in CISPR 16-4:

Measurement	Frequency	Uncertainty
Conducted emissions	9kHz~30MHz	2.44 dB
	30MHz ~ 200MHz	3.73 dB
Radiated emissions	200MHz ~1000MHz	3.74 dB
	1GHz ~ 18GHz	2.20 dB
	18GHz ~ 40GHz	1.88 dB



3. GENERAL INFORMATION

3.1 GENERAL DESCRIPTION OF EUT

EUT	11a/b/g Wireless PC Card with XJACK Antenna
MODEL NO.	SL-3050
POWER SUPPLY	3.3Vdc from host equipment
MODULATION TYPE	CCK, DQPSK, DBPSK for DSSS 64QAM, 16QAM, QPSK, BPSK for OFDM
MODULATION TECHNOLOGY	DSSS, OFDM
TRANSFER RATE	802.11b: 11/5.5/2/1Mbps 802.11g: 54/48/36/24/18/12/9/6Mbps (Turbo mode: up to 108Mbps *see Note 3) 802.11a: 54/48/36/24/18/12/9/6Mbps (Turbo mode: up to 108Mbps *see Note 3)
FREQUENCY RANGE	802.11b & 802.11g: 2.412 ~ 2.462GHz 802.11a: 5.150 ~ 5.350GHz and 5.725 ~ 5.850GHz
NUMBER OF CHANNEL	802.11b & 802.11g: 11 for Normal mode / 1 for Turbo mode 802.11a: 13 for Normal mode / 5 for Turbo mode
CHANNEL SPACING	802.11b & 802.11g: 5MHz 802.11a: 20MHz for Normal mode / 40MHz for Turbo mode
OUTPUT POWER	66.222mW for 802.11b 89.743mW for 802.11g 37.670mW for 5.150 ~ 5.350GHz 63.680mW for 5.725 ~ 5.850GHz
ANTENNA TYPE	2.4GHz band: Printed antenna with 2.5dBi gain 5GHz band: Printed antenna with 0dBi gain
DATA CABLE	NA
I/O PORTS	NA
ASSOCIATED DEVICES	NA

NOTE:

1. The EUT operates in both the 5GHz and 2.4GHz Bands and compatibility with 802.11a and 802.11b, 802.11g technology.
2. There are three model names provided to this EUT. Please refer to the table as below for EUT's information:

Brand	Model Name
3Com	SL-3050
3Com	3CRPAG175B
3Com	3CRPAG175B-AP



3. This EUT is capable of providing data rates of up to 108 Mbps in Turbo mode depending upon reception quality.
4. The above EUT information was declared by the manufacturer and for more detailed features description, please refer to the manufacturer's specifications or User's Manual.

3.2 DESCRIPTION OF TEST MODES

Operated in 5150 ~ 5250MHz, 5250MHz ~ 5350MHz bands:

Eight channels are provided to this EUT for normal mode.

Channel	Frequency
1	5180 MHz
2	5200 MHz
3	5220 MHz
4	5240 MHz
5	5260 MHz
6	5280 MHz
7	5300 MHz
8	5320 MHz

Three channels are provided to this EUT for turbo mode.

Channel	Frequency
1	5210 MHz
2	5250 MHz
3	5290 MHz

3.2.1 CONFIGURATION OF SYSTEM UNDER TEST

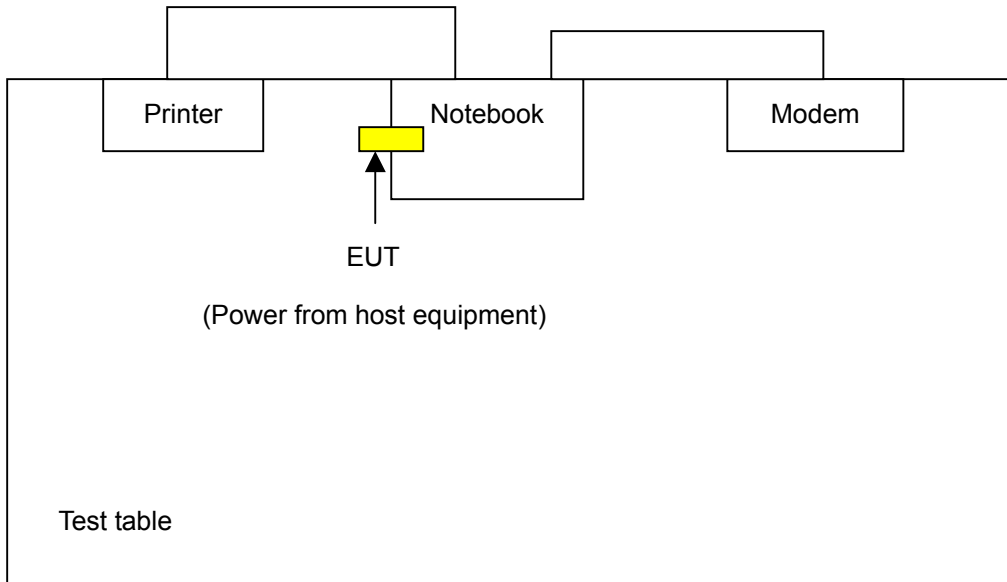



3.2.2 TEST MODE APPLICABILITY AND TESTED CHANNEL DETAIL:

EUT configure mode	Applicable to				Description
	PLC	RE<1G	RE≥1G	APCM	
-	X	X	X	X	NA

Where PLC: Power Line Conducted Emission RE<1G RE: Radiated Emission below 1GHz
 RE≥1G: Radiated Emission above 1GHz APCM: Antenna Port Conducted Measurement

Power Line Conducted Emission Test:

- Pre-Scan has been conducted to determine the worst-case mode from all possible combinations between available modulations, data rates and antenna ports (if EUT with antenna diversity architecture).
- Following channel(s) was (were) selected for the final test as listed below.

Mode	Available Channel	Tested Channel	Modulation Technology	Modulation Type	Data Rate (Mbps)
802.11a	1 to 8	5	OFDM	BPSK	6

Radiated Emission Test (Below 1 GHz):

- Pre-Scan has been conducted to determine the worst-case mode from all possible combinations between available modulations, data rates and antenna ports (if EUT with antenna diversity architecture).
- Following channel(s) was (were) selected for the final test as listed below.

Mode	Available Channel	Tested Channel	Modulation Technology	Modulation Type	Data Rate (Mbps)
802.11a	1 to 8	5	OFDM	BPSK	6

Radiated Emission Test (Above 1 GHz):

- Pre-Scan has been conducted to determine the worst-case mode from all possible combinations between available modulations, data rates and antenna ports (if EUT with antenna diversity architecture).
- Following channel(s) was (were) selected for the final test as listed below.

Mode	Available Channel	Tested Channel	Modulation Technology	Modulation Type	Data Rate (Mbps)
802.11a	1 to 8	1, 4, 5, 8	OFDM	BPSK	6
802.11a Turbo	1 to 3	1, 2, 3	OFDM	BPSK	12



Bandedge Measurement:

- Pre-Scan has been conducted to determine the worst-case mode from all possible combinations between available modulations, data rates and antenna ports (if EUT with antenna diversity architecture).
- Following channel(s) was (were) selected for the final test as listed below.

Mode	Available Channel	Tested Channel	Modulation Technology	Modulation Type	Data Rate (Mbps)
802.11a	1 to 8	1, 8	OFDM	BPSK	6
802.11a Turbo	1 to 3	1, 3	OFDM	BPSK	12

Antenna Port Conducted Measurement:

- Pre-Scan has been conducted to determine the worst-case mode from all possible combinations between available modulations, data rates and antenna ports (if EUT with antenna diversity architecture).
- Following channel(s) was (were) selected for the final test as listed below.

Mode	Available Channel	Tested Channel	Modulation Technology	Modulation Type	Data Rate (Mbps)
802.11a	1 to 8	1, 4, 5, 8	OFDM	BPSK	6
802.11a Turbo	1 to 3	1, 2, 3	OFDM	BPSK	12



3.3 GENERAL DESCRIPTION OF APPLIED STANDARDS

The EUT is a 11a/b/g Wireless PC Card with XJACK Antenna. According to the specifications of the manufacturer, it must comply with the requirements of the following standards:

FCC Part 15, Subpart E (15.407)

ANSI C63.4-2003

All test items have been performed and recorded as per the above standards.

NOTE: The EUT is also considered as a kind of computer peripheral, because the connection to computer is necessary for typical use. It has been verified to comply with the requirements of FCC Part 15, Subpart B, Class B (DoC). The test report has been issued separately.



3.4 DESCRIPTION OF SUPPORT UNITS

The EUT has been tested as an independent unit together with other necessary accessories or support units. The following support units or accessories were used to form a representative test configuration during the tests.

NO.	PRODUCT	BRAND	MODEL NO.	SERIAL NO.	FCC ID
1	NOTEBOOK COMPUTER	DELL	PP05L	20838027664	E2K24CLNS
2	PRINTER	EPSON	LQ-300+	DCGY054147	FCC DoC Approved
3	MODEM	ACEEX	1414V/3	0401008269	IFAXDM1414

NO.	SIGNAL CABLE DESCRIPTION OF THE ABOVE SUPPORT UNITS
1	NA
2	1.8 m shielded cable without core
3	1.8 m shielded cable without core

NOTE: All power cords of the above support units are non shielded (1.8m).



4. TEST TYPES AND RESULTS (5150 ~ 5350MHz Band)

4.1 CONDUCTED EMISSION MEASUREMENT

4.1.1 LIMITS OF CONDUCTED EMISSION MEASUREMENT

FREQUENCY OF EMISSION (MHz)	CONDUCTED LIMIT (dB μ V)	
	Quasi-peak	Average
0.15-0.5	66 to 56	56 to 46
0.5-5	56	46
5-30	60	50

- NOTE:**
1. The lower limit shall apply at the transition frequencies.
 2. The limit decreases in line with the logarithm of the frequency in the range of 0.15 to 0.50 MHz.
 3. All emanations from a class A/B digital device or system, including any network of conductors and apparatus connected thereto, shall not exceed the level of field strengths specified above.

4.1.2 TEST INSTRUMENTS

DESCRIPTION & MANUFACTURER	MODEL NO.	SERIAL NO.	CALIBRATED UNTIL
Test Receiver ROHDE & SCHWARZ	ESCS30	100291	Nov. 16, 2005
RF signal cable Woken	5D-FB	Cable-HYC01-01	Jan. 09, 2006
LISN ROHDE & SCHWARZ	ESH3-Z5	100312	Feb. 15, 2006
LISN ROHDE & SCHWARZ	ESH2-Z5	100104	Feb. 15, 2006
Software ADT	ADT_Cond_V3	NA	NA

- NOTE:**
1. The calibration interval of the above test instruments is 12 months and the calibrations are traceable to NML/ROC and NIST/USA.
 2. The test was performed in HwaYa Shielded Room 1.
 3. The VCCI Site Registration No. is C-2040.



4.1.3 TEST PROCEDURES

- a. The EUT was placed 0.4 meters from the conducting wall of the shielded room with EUT being connected to the power mains through a line impedance stabilization network (LISN). Other support units were connected to the power mains through another LISN. The two LISNs provide 50 ohm/ 50uH of coupling impedance for the measuring instrument.
- b. Both lines of the power mains connected to the EUT were checked for maximum conducted interference.
- c. The frequency range from 150kHz to 30MHz was searched. Emission levels under (Limit - 20dB) was not recorded.

4.1.4 DEVIATION FROM TEST STANDARD

No deviation

4.1.5 TEST SETUP

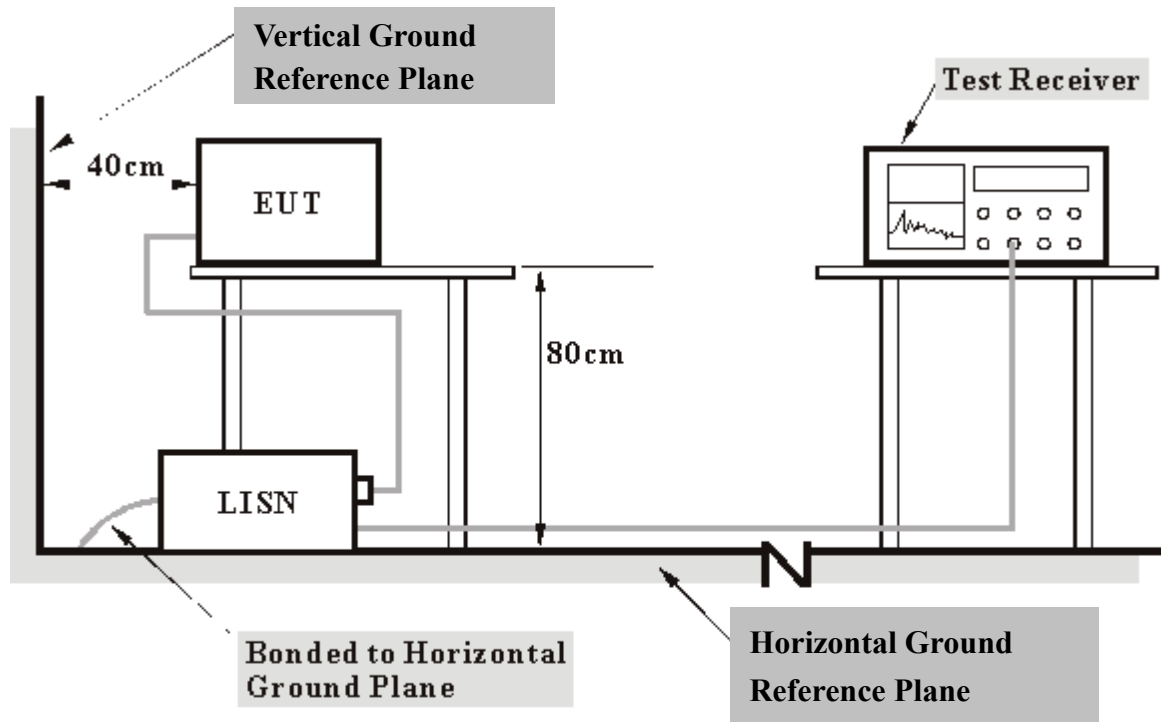

- Note:**
1. Support units were connected to second LISN.
 2. Both of LISNs (AMN) 80 cm from EUT and at the least 80 cm from other units and other metal planes support units.

For the actual test configuration, please refer to the related item – Photographs of the Test Configuration.

4.1.6 EUT OPERATING CONDITIONS

- a. Connected the EUT with notebook system and placed on a testing table.
- b. The notebook system ran a test program (provided by manufacturer) to enable EUT under transmission/receiving condition continuously at specific channel frequency.
- c. The notebook system sent "H" messages to its screen.
- d. The notebook system sent "H" messages to modem.
- e. The notebook system sent "H" messages to printer, and the printer printed them on paper.
- f. Steps c ~ e were repeated.



4.1.7 TEST RESULTS

Conducted Worst-Case Data

EUT	11a/b/g Wireless PC Card with XJACK Antenna	MEASUREMENT DETAIL	
MODEL	SL-3050	PHASE	Line 1
CHANNEL	Channel 5	6dB BANDWIDTH	9 kHz
MODULATION TYPE	BPSK	ENVIRONMENTAL CONDITIONS	20deg. C, 60%RH, 991hPa
TRANSFER RATE	6Mbps	INPUT POWER (SYSTEM)	120Vac, 60 Hz
TESTED BY	Match Tsui		

No	Freq. [MHz]	Corr. Factor (dB)	Reading Value [dB (uV)]		Emission Level [dB (uV)]		Limit [dB (uV)]		Margin (dB)	
			Q.P.	AV.	Q.P.	AV.	Q.P.	AV.	Q.P.	AV.
			1	0.166	0.11	44.69	-	44.80	-	65.18
2	0.209	0.11	45.83	23.60	45.94	23.71	63.26	53.26	-17.32	-29.55
3	0.912	0.22	23.54	-	23.76	-	56.00	46.00	-32.24	-
4	2.141	0.27	26.84	-	27.11	-	56.00	46.00	-28.89	-
5	3.871	0.38	23.28	-	23.66	-	56.00	46.00	-32.34	-
6	9.309	0.52	21.68	-	22.20	-	60.00	50.00	-37.80	-

- REMARKS:**
1. Q.P. and AV. are abbreviations of quasi-peak and average individually.
 2. "-": The Quasi-peak reading value also meets average limit and measurement with the average detector is unnecessary.
 3. The emission levels of other frequencies were very low against the limit.
 4. Margin value = Emission level - Limit value
 5. Correction factor = Insertion loss + Cable loss
 6. Emission Level = Correction Factor + Reading Value.

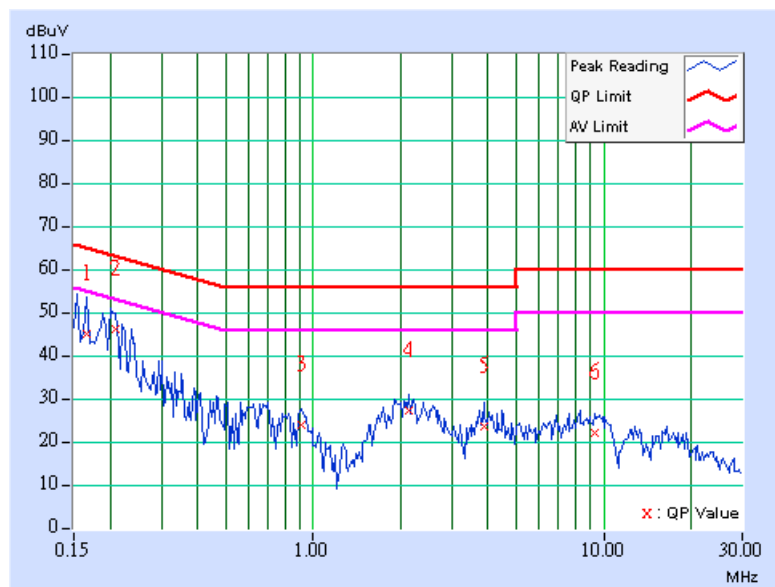



EUT	11a/b/g Wireless PC Card with XJACK Antenna	MEASUREMENT DETAIL	
MODEL	SL-3050	PHASE	Line 2
CHANNEL	Channel 5	6dB BANDWIDTH	9 kHz
MODULATION TYPE	BPSK	ENVIRONMENTAL CONDITIONS	20deg. C, 60%RH, 991hPa
TRANSFER RATE	6Mbps	INPUT POWER (SYSTEM)	120Vac, 60 Hz
TESTED BY	Match Tsui		

No	Freq. [MHz]	Corr. Factor (dB)	Reading Value [dB (uV)]		Emission Level [dB (uV)]		Limit [dB (uV)]		Margin (dB)	
			Q.P.	AV.	Q.P.	AV.	Q.P.	AV.	Q.P.	AV.
			1	0.193	0.11	46.47	25.09	46.58	25.20	63.91
2	0.232	0.11	43.17	25.25	43.28	25.36	62.38	52.38	-19.10	-27.02
3	0.615	0.16	29.10	-	29.26	-	56.00	46.00	-26.74	-
4	2.250	0.28	23.47	-	23.75	-	56.00	46.00	-32.25	-
5	5.301	0.40	18.55	-	18.95	-	60.00	50.00	-41.05	-
6	15.344	0.47	17.03	-	17.50	-	60.00	50.00	-42.50	-

- REMARKS:**
1. Q.P. and AV. are abbreviations of quasi-peak and average individually.
 2. "-": The Quasi-peak reading value also meets average limit and measurement with the average detector is unnecessary.
 3. The emission levels of other frequencies were very low against the limit.
 4. Margin value = Emission level - Limit value
 5. Correction factor = Insertion loss + Cable loss
 6. Emission Level = Correction Factor + Reading Value.

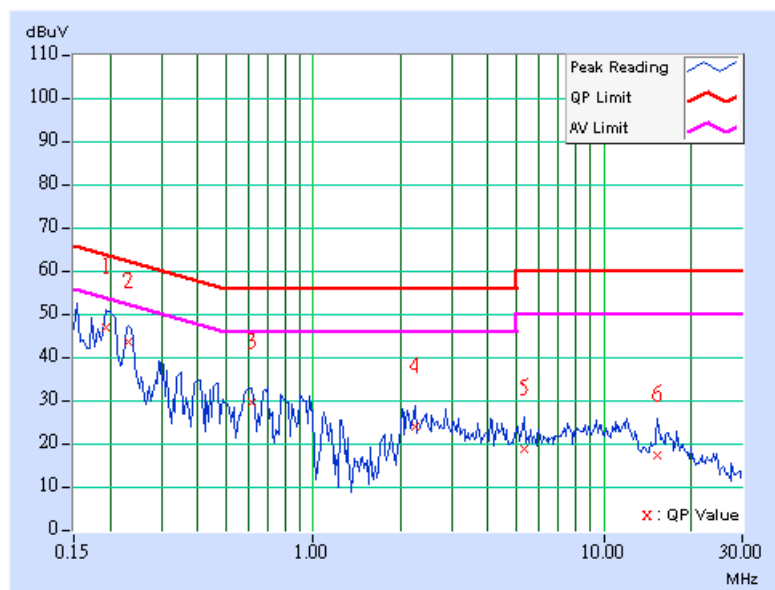



4.2 RADIATED EMISSION MEASUREMENT

4.2.1 LIMITS OF RADIATED EMISSION MEASUREMENT

Emissions radiated outside of the specified bands, shall be according to the general radiated limits in 15.209 as following:

Frequencies (MHz)	Field strength (microvolts/meter)	Measurement distance (meters)
0.009-0.490	2400/F(kHz)	300
0.490-1.705	24000/F(kHz)	30
1.705-30.0	30	30
30-88	100	3
88-216	150	3
216-960	200	3
Above 960	500	3

NOTE:

1. The lower limit shall apply at the transition frequencies.
2. Emission level (dBuV/m) = 20 log Emission level (uV/m).
3. As shown in 15.35(b), for frequencies above 1000MHz, the field strength limits are based on average detector, however, the peak field strength of any emission shall not exceed the maximum permitted average limits, specified above by more than 20dB under any condition of modulation.



4.2.2 LIMITS OF UNWANTED EMISSION OUT OF THE RESTRICTED BANDS

Frequencies (MHz)	EIRP Limit (dBm)	Equivalent Field Strength at 3m (dB μ V/m) *note 3
5150~5250	-27	68.3
5250~5350	-27	68.3
5725~5825	-27 *note 1	68.3
	-17 *note 2	78.3

NOTE:

1. For frequencies 10MHz or greater above or below the band edge.
2. All emissions within the frequency range from the band edge to 10MHz above or below the band edge.
3. The following formula is used to convert the equipment isotropic radiated power (eirp) to field strength

$$E = \frac{1000000\sqrt{30P}}{3} \quad \mu\text{V/m, where P is the eirp (Watts)}$$



4.2.3 TEST INSTRUMENTS

DESCRIPTION & MANUFACTURER	MODEL NO.	SERIAL NO.	CALIBRATED UNTIL
Test Receiver ROHDE & SCHWARZ	ESIB7	100188	Dec. 19, 2005
Spectrum Analyzer ROHDE & SCHWARZ	FSP40	100039	Nov. 21, 2005
BILOG Antenna SCHWARZBECK	VULB9168	9168-157	Jan. 22, 2006
HORN Antenna SCHWARZBECK	BBHA 9120 D	9120D-407	Jan. 16, 2006
HORN Antenna SCHWARZBECK	BBHA 9170	BBHA 9170241	Feb. 23, 2006
Preamplifier Agilent	8449B	3008A01961	Nov. 09, 2005
Preamplifier Agilent	8447D	2944A10629	Nov. 09, 2005
RF signal cable HUBER+SUHNER	SUCOFLEX 104	218182/4	Feb. 17, 2006
RF signal cable HUBER+SUHNER	SUCOFLEX 104	218194/4	Feb. 17, 2006
Software ADT.	ADT_Radiated_V5.14	NA	NA
Antenna Tower ADT.	AT100	AT93021702	NA
Turn Table ADT.	TT100.	TT93021702	NA
Controller ADT.	SC100.	SC93021702	NA

- NOTE:**
1. The calibration interval of the above test instruments is 12 months and the calibrations are traceable to NML/ROC and NIST/USA.
 2. The test was performed in HwaYa Chamber 1.
 3. The horn antenna and HP preamplifier (model: 8449B) are used only for the measurement of emission frequency above 1GHz if tested.
 4. The IC Site Registration No. is IC4924-2.



4.2.4 TEST PROCEDURES

- a. The EUT was placed on the top of a rotating table 0.8 meters above the ground at a 3 meter semi-anechoic chamber. The table was rotated 360 degrees to determine the position of the highest radiation.
- b. The EUT was set 3 meters away from the interference-receiving antenna, which was mounted on the top of a variable-height antenna tower.
- c. The antenna is a broadband antenna, and its height is varied from one meter to four meters above the ground to determine the maximum value of the field strength. Both horizontal and vertical polarizations of the antenna are set to make the measurement.
- d. For each suspected emission, the EUT was arranged to its worst case and then the antenna was tuned to heights from 1 meter to 4 meters and the rotatable table was turned from 0 degrees to 360 degrees to find the maximum reading.
- e. The test-receiver system was set to Peak Detect Function and Specified Bandwidth with Maximum Hold Mode.
- f. If the emission level of the EUT in peak mode was 10dB lower than the limit specified, then testing could be stopped and the peak values of the EUT would be reported. Otherwise the emissions that did not have 10dB margin would be re-tested one by one using peak, quasi-peak or average method as specified and then reported in a data sheet.

NOTE:

1. The resolution bandwidth and video bandwidth of test receiver/spectrum analyzer is 120kHz for Peak detection (PK) and Quasi-peak detection (QP) at frequency below 1GHz.
2. The resolution bandwidth and video bandwidth of test receiver/spectrum analyzer is 1 MHz for Peak detection at frequency above 1GHz.
3. The resolution bandwidth of test receiver/spectrum analyzer is 1 MHz and the video bandwidth is 10 Hz for Average detection (AV) at frequency above 1GHz.

4.2.5 DEVIATION FROM TEST STANDARD

No deviation

4.2.6 TEST SETUP

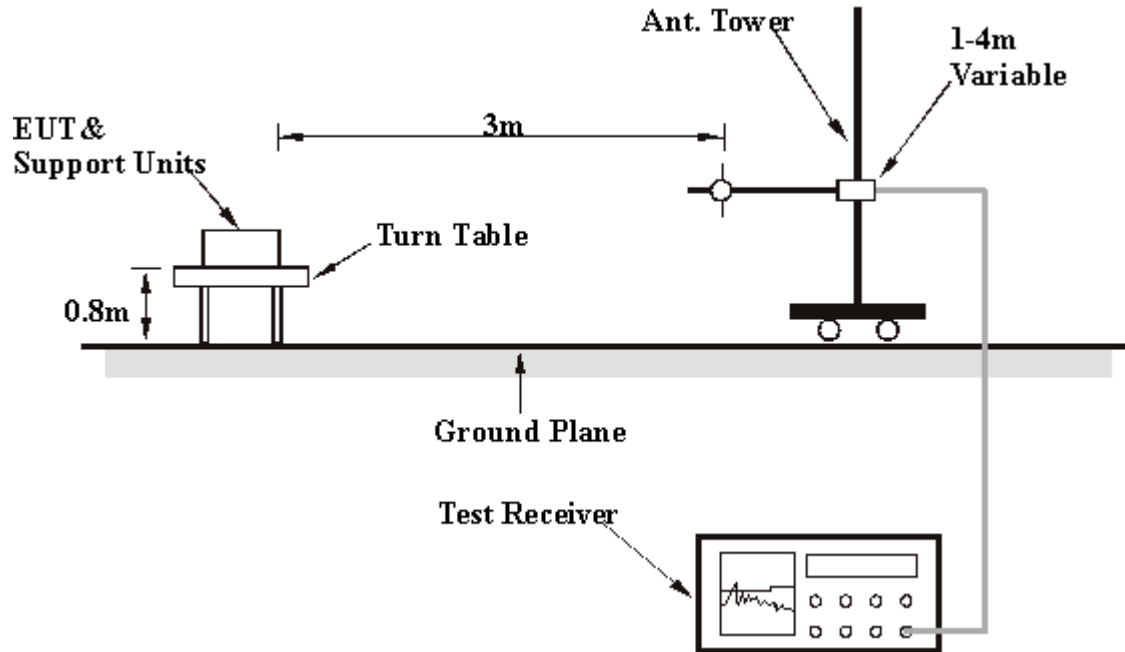

For the actual test configuration, please refer to the related item – Photographs of the Test Configuration.

4.2.7 EUT OPERATING CONDITION

Same as 4.1.6



4.2.8 TEST RESULTS

Below 1GHz Worst-Case Data

EUT	11a/b/g Wireless PC Card with XJACK Antenna	MEASUREMENT DETAIL	
MODEL	SL-3050	FREQUENCY RANGE	Below 1000MHz
CHANNEL	Channel 5	DETECTOR FUNCTION	Quasi-Peak
MODULATION TYPE	BPSK	ENVIRONMENTAL CONDITIONS	25deg. C, 64%RH, 991hPa
TRANSFER RATE	6Mbps	INPUT POWER (SYSTEM)	120Vac, 60 Hz
TESTED BY	Match Tsui		

ANTENNA POLARITY & TEST DISTANCE: HORIZONTAL AT 3 M

No.	Freq. (MHz)	Emission Level (dBuV/m)	Limit (dBuV/m)	Margin (dB)	Antenna Height (m)	Table Angle (Degree)	Raw Value (dBuV)	Correction Factor (dB/m)
1	78.60	23.75 QP	40.00	-16.25	2.00 H	85	13.64	10.11
2	119.42	34.39 QP	43.50	-9.11	1.50 H	97	21.65	12.74
3	166.07	32.56 QP	43.50	-10.94	1.50 H	76	18.49	14.07
4	201.06	26.51 QP	43.50	-16.99	1.50 H	76	15.35	11.16
5	232.16	28.56 QP	46.00	-17.44	1.50 H	256	16.15	12.41
6	265.21	32.56 QP	46.00	-13.44	1.00 H	238	19.12	13.45
7	399.34	34.42 QP	46.00	-11.58	1.75 H	73	17.80	16.62
8	531.52	28.98 QP	46.00	-17.02	1.50 H	103	9.75	19.23
9	584.01	28.82 QP	46.00	-17.18	1.50 H	256	8.34	20.48
10	665.65	35.35 QP	46.00	-10.65	2.00 H	40	13.56	21.79
11	702.59	40.48 QP	46.00	-5.52	1.00 H	64	18.17	22.31
12	930.02	34.62 QP	46.00	-11.38	1.25 H	82	9.21	25.41

ANTENNA POLARITY & TEST DISTANCE: VERTICAL AT 3 M

No.	Freq. (MHz)	Emission Level (dBuV/m)	Limit (dBuV/m)	Margin (dB)	Antenna Height (m)	Table Angle (Degree)	Raw Value (dBuV)	Correction Factor (dB/m)
1	78.60	29.57 QP	40.00	-10.43	1.00 V	67	19.46	10.11
2	119.42	30.14 QP	43.50	-13.36	1.25 V	256	17.40	12.74
3	265.21	36.89 QP	46.00	-9.11	1.75 V	334	23.44	13.45
4	399.34	34.33 QP	46.00	-11.67	1.00 V	10	17.71	16.62
5	584.01	31.73 QP	46.00	-14.27	1.00 V	352	11.25	20.48
6	665.65	31.71 QP	46.00	-14.29	1.00 V	196	9.91	21.79
7	702.59	37.43 QP	46.00	-8.57	2.00 V	313	15.12	22.31
8	930.02	33.72 QP	46.00	-12.28	1.00 V	10	8.31	25.41

- REMARKS:**
1. Emission level(dBuV/m)=Raw Value(dBuV) + Correction Factor(dB/m)
 2. Correction Factor(dB/m) = Antenna Factor (dB/m) + Cable Factor (dB)
 3. The other emission levels were very low against the limit.
 4. Margin value = Emission level – Limit value



802.11a OFDM modulation

EUT	11a/b/g Wireless PC Card with XJACK Antenna	MEASUREMENT DETAIL	
MODEL	SL-3050	FREQUENCY RANGE	1 ~ 40 GHz
CHANNEL	Channel 1	DETECTOR FUNCTION	Peak(PK) Average (AV)
MODULATION TYPE	BPSK	ENVIRONMENTAL CONDITIONS	25deg. C, 64%RH, 991hPa
TRANSFER RATE	6Mbps	INPUT POWER (SYSTEM)	120Vac, 60 Hz
TESTED BY	Match Tsui		

ANTENNA POLARITY & TEST DISTANCE: HORIZONTAL AT 3 M

No.	Freq. (MHz)	Emission Level (dBuV/m)	Limit (dBuV/m)	Margin (dB)	Antenna Height (m)	Table Angle (Degree)	Raw Value (dBuV)	Correction Factor (dB/m)
1	3453.00	44.00 PK	68.30	-24.30	1.08 H	360	11.12	32.88
2	#5150.00	51.85 PK	74.00	-22.15	1.04 H	117	14.80	37.05
2	#5150.00	41.98 AV	54.00	-12.02	1.04 H	117	4.92	37.05
3	*5180.00	104.62 PK			1.04 H	118	67.53	37.09
3	*5180.00	94.11 AV			1.04 H	118	57.02	37.09
4	10360.00	53.62 PK	68.30	-14.68	1.05 H	10	7.56	46.06

ANTENNA POLARITY & TEST DISTANCE: VERTICAL AT 3 M

No.	Freq. (MHz)	Emission Level (dBuV/m)	Limit (dBuV/m)	Margin (dB)	Antenna Height (m)	Table Angle (Degree)	Raw Value (dBuV)	Correction Factor (dB/m)
1	3453.00	46.60 PK	68.30	-21.70	1.01 V	254	13.72	32.88
2	#5150.00	54.69 PK	74.00	-19.31	1.45 V	259	17.63	37.05
2	#5150.00	45.19 AV	54.00	-8.81	1.45 V	259	8.13	37.05
3	*5180.00	106.46 PK			1.45 V	259	69.37	37.09
3	*5180.00	96.96 AV			1.45 V	259	59.87	37.09
4	10360.00	57.60 PK	68.30	-10.70	1.15 V	264	11.54	46.06
5	#15540.00	61.58 PK	74.00	-12.42	1.00 V	68	13.12	48.46
5	#15540.00	47.38 AV	54.00	-6.62	1.00 V	68	-1.08	48.46

- NOTE:**
1. Emission level(dBuV/m)=Raw Value(dBuV) + Correction Factor(dB/m)
 2. Correction Factor(dB/m) = Antenna Factor (dB/m) + Cable Factor (dB)
 3. The other emission levels were very low against the limit.
 4. Margin value = Emission level – Limit value
 5. "*" : Fundamental frequency
 6. "#"The radiated frequency falling in the restricted band.



EUT	11a/b/g Wireless PC Card with XJACK Antenna	MEASUREMENT DETAIL	
MODEL	SL-3050	FREQUENCY RANGE	1 ~ 40 GHz
CHANNEL	Channel 4	DETECTOR FUNCTION	Peak(PK) Average (AV)
MODULATION TYPE	BPSK	ENVIRONMENTAL CONDITIONS	25deg. C, 64%RH, 991hPa
TRANSFER RATE	6Mbps	INPUT POWER (SYSTEM)	120Vac, 60 Hz
TESTED BY	Match Tsui		

ANTENNA POLARITY & TEST DISTANCE: HORIZONTAL AT 3 M

No.	Freq. (MHz)	Emission Level (dBuV/m)	Limit (dBuV/m)	Margin (dB)	Antenna Height (m)	Table Angle (Degree)	Raw Value (dBuV)	Correction Factor (dB/m)
1	3493.00	44.57 PK	68.30	-23.73	1.06 H	360	11.67	32.91
2	*5240.00	104.42 PK			1.02 H	119	67.22	37.20
2	*5240.00	94.09 AV			1.02 H	119	56.89	37.20
3	10480.00	54.11 PK	68.30	-14.19	1.45 H	259	7.75	46.36

ANTENNA POLARITY & TEST DISTANCE: VERTICAL AT 3 M

No.	Freq. (MHz)	Emission Level (dBuV/m)	Limit (dBuV/m)	Margin (dB)	Antenna Height (m)	Table Angle (Degree)	Raw Value (dBuV)	Correction Factor (dB/m)
1	3493.00	46.42 PK	68.30	-21.88	1.00 V	250	13.52	32.91
2	*5240.00	105.38 PK			1.45 V	235	68.18	37.20
2	*5240.00	95.26 AV			1.45 V	235	58.06	37.20
3	10480.00	57.86 PK	68.30	-10.44	1.14 V	300	11.50	46.36
4	#15720.00	61.74 PK	74.00	-12.26	1.04 V	89	13.91	47.83
4	#15720.00	47.64 AV	54.00	-6.36	1.04 V	89	-0.19	47.83

- NOTE:**
1. Emission level(dBuV/m)=Raw Value(dBuV) + Correction Factor(dB/m)
 2. Correction Factor(dB/m) = Antenna Factor (dB/m) + Cable Factor (dB)
 3. The other emission levels were very low against the limit.
 4. Margin value = Emission level – Limit value
 5. "*" : Fundamental frequency
 6. "#"The radiated frequency falling in the restricted band.



EUT	11a/b/g Wireless PC Card with XJACK Antenna	MEASUREMENT DETAIL	
MODEL	SL-3050	FREQUENCY RANGE	1 ~ 40 GHz
CHANNEL	Channel 5	DETECTOR FUNCTION	Peak(PK) Average (AV)
MODULATION TYPE	BPSK	ENVIRONMENTAL CONDITIONS	25deg. C, 64%RH, 991hPa
TRANSFER RATE	6Mbps	INPUT POWER (SYSTEM)	120Vac, 60 Hz
TESTED BY	Match Tsui		

ANTENNA POLARITY & TEST DISTANCE: HORIZONTAL AT 3 M

No.	Freq. (MHz)	Emission Level (dBuV/m)	Limit (dBuV/m)	Margin (dB)	Antenna Height (m)	Table Angle (Degree)	Raw Value (dBuV)	Correction Factor (dB/m)
1	3506.00	45.44 PK	68.30	-22.86	1.05 H	360	12.51	32.93
2	*5260.00	104.26 PK			1.01 H	121	67.01	37.25
2	*5260.00	94.26 AV			1.01 H	121	57.01	37.25
3	10520.00	54.85 PK	68.30	-13.45	1.00 H	360	8.37	46.48

ANTENNA POLARITY & TEST DISTANCE: VERTICAL AT 3 M

No.	Freq. (MHz)	Emission Level (dBuV/m)	Limit (dBuV/m)	Margin (dB)	Antenna Height (m)	Table Angle (Degree)	Raw Value (dBuV)	Correction Factor (dB/m)
1	3506.00	46.12 PK	68.30	-22.18	1.00 V	82	13.19	32.93
2	*5260.00	105.42 PK			1.30 V	261	68.17	37.25
2	*5260.00	96.92 AV			1.30 V	261	59.67	37.25
3	10520.00	57.83 PK	68.30	-10.47	1.11 V	254	11.35	46.48
4	#15780.00	62.42 PK	74.00	-11.58	1.02 V	101	14.82	47.60
4	#15780.00	48.44 AV	54.00	-5.56	1.02 V	101	0.84	47.60

- NOTE:**
1. Emission level(dBuV/m)=Raw Value(dBuV) + Correction Factor(dB/m)
 2. Correction Factor(dB/m) = Antenna Factor (dB/m) + Cable Factor (dB)
 3. The other emission levels were very low against the limit.
 4. Margin value = Emission level – Limit value
 5. "*" : Fundamental frequency
 6. "#"The radiated frequency falling in the restricted band.

EUT	11a/b/g Wireless PC Card with XJACK Antenna	MEASUREMENT DETAIL	
MODEL	SL-3050	FREQUENCY RANGE	1 ~ 40 GHz
CHANNEL	Channel 8	DETECTOR FUNCTION	Peak(PK) Average (AV)
MODULATION TYPE	BPSK	ENVIRONMENTAL CONDITIONS	25deg. C, 64%RH, 991hPa
TRANSFER RATE	6Mbps	INPUT POWER (SYSTEM)	120Vac, 60 Hz
TESTED BY	Match Tsui		

ANTENNA POLARITY & TEST DISTANCE: HORIZONTAL AT 3 M

No.	Freq. (MHz)	Emission Level (dBuV/m)	Limit (dBuV/m)	Margin (dB)	Antenna Height (m)	Table Angle (Degree)	Raw Value (dBuV)	Correction Factor (dB/m)
1	3546.00	43.65 PK	68.30	-24.65	1.15 H	213	10.61	33.04
2	*5320.00	104.26 PK			1.12 H	126	66.90	37.36
2	*5320.00	94.01 AV			1.12 H	126	56.65	37.36
3	#5350.00	53.26 PK	74.00	-20.74	1.12 H	126	15.87	37.39
3	#5350.00	43.01 AV	54.00	-10.99	1.12 H	126	5.62	37.39
4	#10640.00	56.48 PK	74.00	-17.52	1.42 H	1	9.76	46.72
4	#10640.00	43.18 AV	54.00	-10.82	1.42 H	1	-3.54	46.72

ANTENNA POLARITY & TEST DISTANCE: VERTICAL AT 3 M

No.	Freq. (MHz)	Emission Level (dBuV/m)	Limit (dBuV/m)	Margin (dB)	Antenna Height (m)	Table Angle (Degree)	Raw Value (dBuV)	Correction Factor (dB/m)
1	3546.00	45.05 PK	68.30	-23.25	1.00 V	250	12.01	33.04
2	*5320.00	105.42 PK			1.27 V	257	68.06	37.36
2	*5320.00	96.42 AV			1.27 V	257	59.06	37.36
3	#5350.00	54.42 PK	74.00	-19.58	1.27 V	257	17.03	37.39
3	#5350.00	45.42 AV	54.00	-8.58	1.27 V	257	8.03	37.39
4	#10640.00	56.46 PK	74.00	-17.54	1.20 V	360	9.74	46.72
4	#10640.00	44.47 AV	54.00	-9.53	1.20 V	360	-2.25	46.72
5	#15960.00	57.03 PK	74.00	-16.97	1.00 V	1	10.05	46.97
5	#15960.00	45.04 AV	54.00	-8.96	1.00 V	1	-1.94	46.97

- NOTE:**
1. Emission level(dBuV/m)=Raw Value(dBuV) + Correction Factor(dB/m)
 2. Correction Factor(dB/m) = Antenna Factor (dB/m) + Cable Factor (dB)
 3. The other emission levels were very low against the limit.
 4. Margin value = Emission level – Limit value
 5. "*" : Fundamental frequency
 6. "#":The radiated frequency falling in the restricted band.



802.11a Turbo OFDM modulation

EUT	11a/b/g Wireless PC Card with XJACK Antenna	MEASUREMENT DETAIL	
MODEL	SL-3050	FREQUENCY RANGE	1 ~ 40 GHz
CHANNEL	Channel 1	DETECTOR FUNCTION	Peak(PK) Average (AV)
MODULATION TYPE	BPSK	ENVIRONMENTAL CONDITIONS	25deg. C, 64%RH, 991hPa
TRANSFER RATE	12Mbps	INPUT POWER (SYSTEM)	120Vac, 60 Hz
TESTED BY	Match Tsui		

ANTENNA POLARITY & TEST DISTANCE: HORIZONTAL AT 3 M

No.	Freq. (MHz)	Emission Level (dBuV/m)	Limit (dBuV/m)	Margin (dB)	Antenna Height (m)	Table Angle (Degree)	Raw Value (dBuV)	Correction Factor (dB/m)
1	3473.00	44.60 PK	68.30	-23.70	1.24 H	32	11.70	32.89
2	#5150.00	48.98 PK	74.00	-25.02	1.02 H	126	11.92	37.05
2	#5150.00	39.25 AV	54.00	-14.75	1.02 H	126	2.20	37.05
3	*5210.00	99.59 PK			1.03 H	125	62.46	37.13
3	*5210.00	90.30 AV			1.03 H	125	53.17	37.13
4	10420.00	54.27 PK	68.30	-14.03	1.08 H	143	8.15	46.12

ANTENNA POLARITY & TEST DISTANCE: VERTICAL AT 3 M

No.	Freq. (MHz)	Emission Level (dBuV/m)	Limit (dBuV/m)	Margin (dB)	Antenna Height (m)	Table Angle (Degree)	Raw Value (dBuV)	Correction Factor (dB/m)
1	3473.00	46.38 PK	68.30	-21.92	1.00 V	84	13.48	32.89
2	#5150.00	87.81 PK	74.00	13.81	1.33 V	260	50.76	37.05
2	#5150.00	78.70 AV	54.00	24.70	1.33 V	260	41.65	37.05
3	*5210.00	101.51 PK			1.33 V	260	64.38	37.13
3	*5210.00	92.40 AV			1.33 V	260	55.27	37.13
4	10420.00	55.44 PK	68.30	-12.86	1.15 V	265	9.32	46.12
5	#15630.00	58.11 PK	74.00	-15.89	1.05 V	112	10.01	48.10
5	#15630.00	45.60 AV	54.00	-8.40	1.05 V	112	-2.50	48.10

- NOTE:**
1. Emission level(dBuV/m)=Raw Value(dBuV) + Correction Factor(dB/m)
 2. Correction Factor(dB/m) = Antenna Factor (dB/m) + Cable Factor (dB)
 3. The other emission levels were very low against the limit.
 4. Margin value = Emission level – Limit value
 5. "*" : Fundamental frequency
 6. "#"The radiated frequency falling in the restricted band.



EUT	11a/b/g Wireless PC Card with XJACK Antenna	MEASUREMENT DETAIL	
MODEL	SL-3050	FREQUENCY RANGE	1 ~ 40 GHz
CHANNEL	Channel 2	DETECTOR FUNCTION	Peak(PK) Average (AV)
MODULATION TYPE	BPSK	ENVIRONMENTAL CONDITIONS	25deg. C, 64%RH, 991hPa
TRANSFER RATE	12Mbps	INPUT POWER (SYSTEM)	120Vac, 60 Hz
TESTED BY	Match Tsui		

ANTENNA POLARITY & TEST DISTANCE: HORIZONTAL AT 3 M

No.	Freq. (MHz)	Emission Level (dBuV/m)	Limit (dBuV/m)	Margin (dB)	Antenna Height (m)	Table Angle (Degree)	Raw Value (dBuV)	Correction Factor (dB/m)
1	3500.00	45.02 PK	68.30	-23.28	1.06 H	360	12.11	32.91
2	*5250.00	99.00 PK			1.05 H	1	61.77	37.23
2	*5250.00	89.50 AV			1.05 H	1	52.27	37.23
3	10500.00	54.68 PK	68.30	-13.62	1.10 H	162	8.24	46.44

ANTENNA POLARITY & TEST DISTANCE: VERTICAL AT 3 M

No.	Freq. (MHz)	Emission Level (dBuV/m)	Limit (dBuV/m)	Margin (dB)	Antenna Height (m)	Table Angle (Degree)	Raw Value (dBuV)	Correction Factor (dB/m)
1	3500.00	45.23 PK	68.30	-23.07	1.11 V	46	12.32	32.91
2	*5250.00	100.90 PK			1.60 V	261	63.67	37.23
2	*5250.00	91.83 AV			1.60 V	261	54.60	37.23
3	10500.00	55.62 PK	68.30	-12.68	1.11 V	300	9.18	46.44
4	#15750.00	58.68 PK	74.00	-15.32	1.04 V	130	10.96	47.72
4	#15750.00	46.23 AV	54.00	-7.77	1.04 V	130	-1.49	47.72

- NOTE:**
1. Emission level(dBuV/m)=Raw Value(dBuV) + Correction Factor(dB/m)
 2. Correction Factor(dB/m) = Antenna Factor (dB/m) + Cable Factor (dB)
 3. The other emission levels were very low against the limit.
 4. Margin value = Emission level – Limit value
 5. "*" : Fundamental frequency
 6. "#" The radiated frequency falling in the restricted band.

EUT	11a/b/g Wireless PC Card with XJACK Antenna	MEASUREMENT DETAIL	
MODEL	SL-3050	FREQUENCY RANGE	1 ~ 40 GHz
CHANNEL	Channel 3	DETECTOR FUNCTION	Peak(PK) Average (AV)
MODULATION TYPE	BPSK	ENVIRONMENTAL CONDITIONS	25deg. C, 64%RH, 991hPa
TRANSFER RATE	12Mbps	INPUT POWER (SYSTEM)	120Vac, 60 Hz
TESTED BY	Match Tsui		

ANTENNA POLARITY & TEST DISTANCE: HORIZONTAL AT 3 M

No.	Freq. (MHz)	Emission Level (dBuV/m)	Limit (dBuV/m)	Margin (dB)	Antenna Height (m)	Table Angle (Degree)	Raw Value (dBuV)	Correction Factor (dB/m)
1	3526.00	45.02 PK	68.30	-23.28	1.25 H	1	12.04	32.98
2	5250.00	47.66 PK	68.30	-20.64	1.04 H	235	10.43	37.23
3	*5290.00	99.12 PK			1.04 H	123	61.80	37.32
3	*5290.00	89.35 AV			1.04 H	123	52.03	37.32
4	10580.00	55.26 PK	68.30	-13.04	1.04 H	130	8.68	46.58

ANTENNA POLARITY & TEST DISTANCE: VERTICAL AT 3 M

No.	Freq. (MHz)	Emission Level (dBuV/m)	Limit (dBuV/m)	Margin (dB)	Antenna Height (m)	Table Angle (Degree)	Raw Value (dBuV)	Correction Factor (dB/m)
1	3526.00	45.58 PK	68.30	-22.72	1.21 V	249	12.60	32.98
2	5250.00	49.30 PK	68.30	-19.00	1.45 V	156	107.78	37.23
3	*5290.00	101.62 PK			1.45 V	156	64.30	37.32
3	*5290.00	92.62 AV			1.45 V	156	55.30	37.32
4	10580.00	55.86 PK	68.30	-12.44	1.04 V	130	9.28	46.58
5	#15870.00	59.42 PK	74.00	-14.58	1.07 V	165	12.20	47.22
5	#15870.00	46.26 AV	54.00	-7.74	1.07 V	165	-0.96	47.22

- NOTE:**
1. Emission level(dBuV/m)=Raw Value(dBuV) + Correction Factor(dB/m)
 2. Correction Factor(dB/m) = Antenna Factor (dB/m) + Cable Factor (dB)
 3. The other emission levels were very low against the limit.
 4. Margin value = Emission level – Limit value
 5. "*" : Fundamental frequency
 6. "#":The radiated frequency falling in the restricted band.



4.3 PEAK TRANSMIT POWER MEASUREMENT

4.3.1 LIMITS OF PEAK TRANSMIT POWER MEASUREMENT

Frequency Band	Limit
5.15 – 5.25GHz	The lesser of 50mW (17dBm) or 4dBm + 10logB
5.25 – 5.35GHz	The lesser of 250mW (24dBm) or 11dBm + 10logB
5.725 – 5.825GHz	The lesser of 1W (30dBm) or 17dBm + 10logB

NOTE: Where B is the 26dB emission bandwidth in MHz.

4.3.2 TEST INSTRUMENTS

Description & Manufacturer	Model No.	Serial No.	Calibrated Until
R&S SPECTRUM ANALYZER	FSEK30	100049	Aug. 12, 2005

NOTE: The calibration interval of the above test instruments is 12 months and the calibrations are traceable to NML/ROC and NIST/USA.

4.3.3 TEST PROCEDURE

1. The transmitter output was connected to the spectrum analyzer.
2. Set span to encompass the entire emission bandwidth of the signal.
3. Set RBW to 1MHz, VBW to 3MHz.
4. Using the spectrum analyzer's channel power measurement function to measure the output power.

NOTE:

The test is performed in accordance with FCC Public Notice: APPENDIX A Guidelines for Assessing Unlicensed National Information Infrastructure (U-NII) Devices – Part 15, Subpart E, August 2002.

The transmitter output operates continuously therefore Method # 1 is used.

4.3.4 DEVIATION FROM TEST STANDARD

No deviation

4.3.5 TEST SETUP

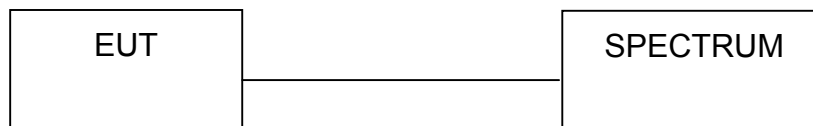

4.3.6 EUT OPERATING CONDITIONS

The software provided by client to enable the EUT under transmission condition continuously at specific channel frequencies individually.



4.3.7 TEST RESULTS

802.11a OFDM modulation

EUT	11a/b/g Wireless PC Card with XJACK Antenna	MODEL	SL-3050
MODULATION TYPE	BPSK	TRANSFER RATE	6Mbps
INPUT POWER (SYSTEM)	120Vac, 60 Hz	ENVIRONMENTAL CONDITIONS	24deg.C, 57%RH, 991hPa
TESTED BY	Match Tsui		

CHANNEL	CHANNEL FREQUENCY (MHz)	PEAK POWER OUTPUT (mW)	PEAK POWER OUTPUT (dBm)	PEAK POWER LIMIT (dBm)	26dBc Occupied Bandwidth (MHz)	PASS/FAIL
1	5180	37.670	15.76	17.00	25.00	PASS
4	5240	36.559	15.63	17.00	26.80	PASS
5	5260	35.075	15.45	24.00	27.30	PASS
8	5320	37.154	15.70	24.00	27.30	PASS

NOTE: The 26dBc Occupied Bandwidth plot, please refer to the following pages.



Peak Power Output:
CH 1

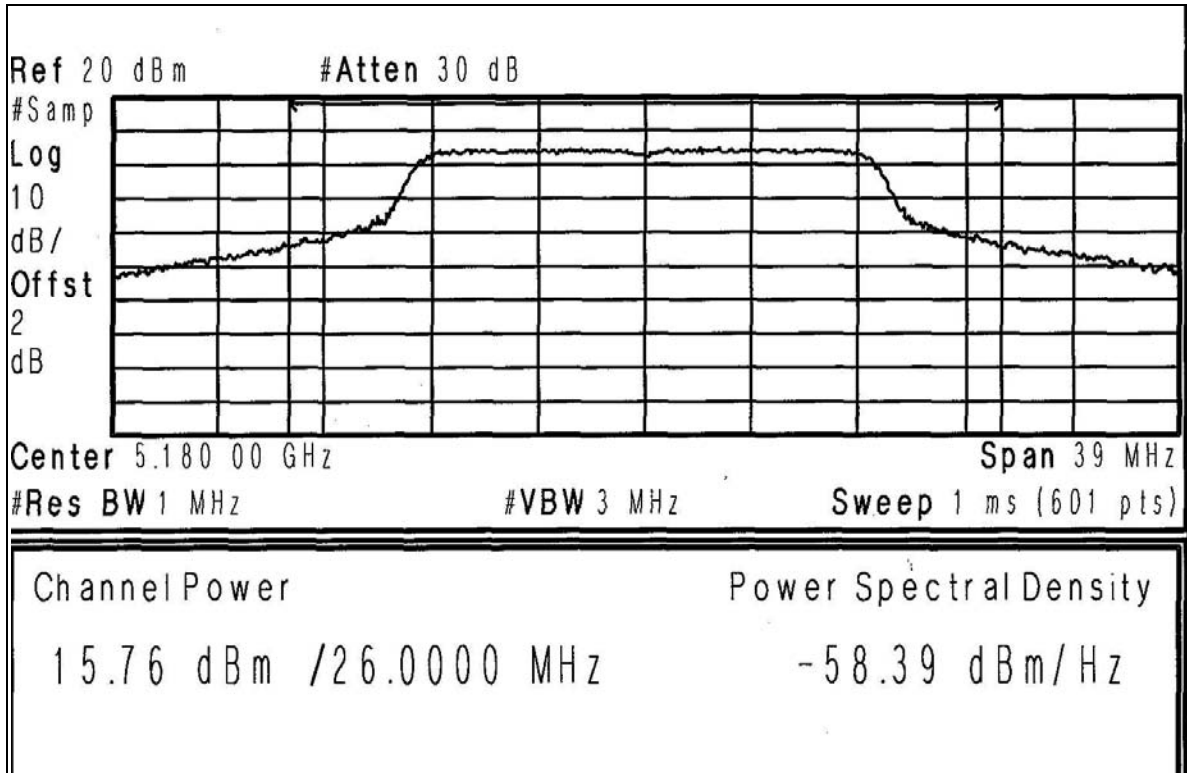

CH 4

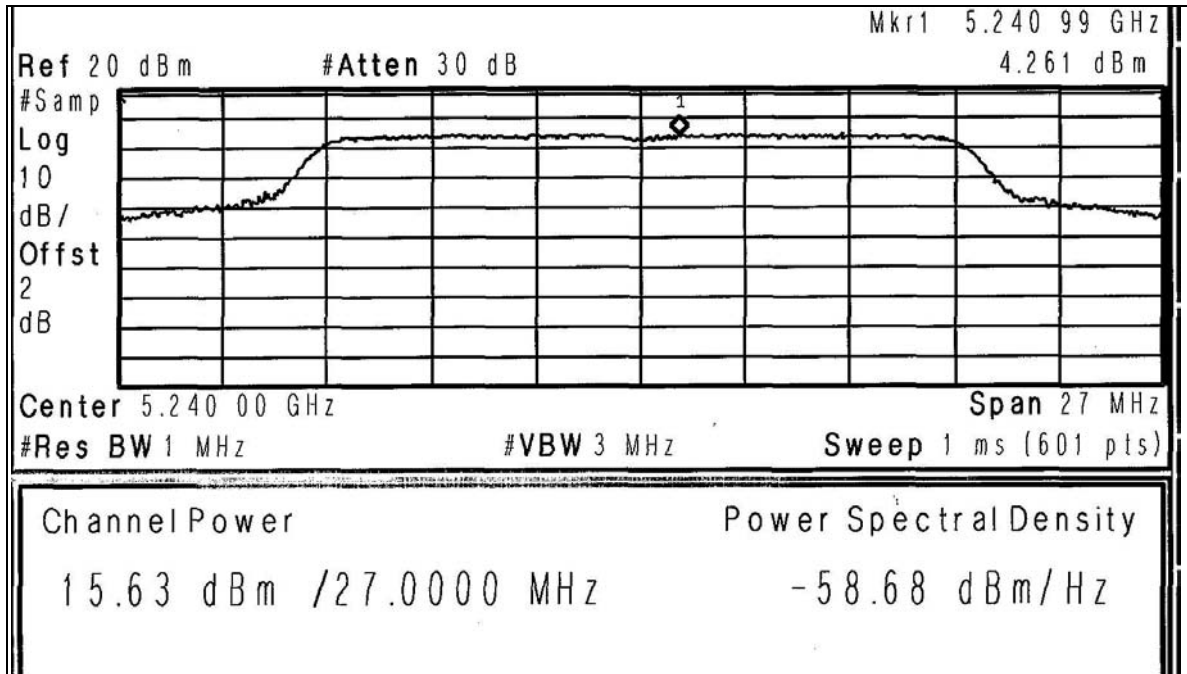



CH 5

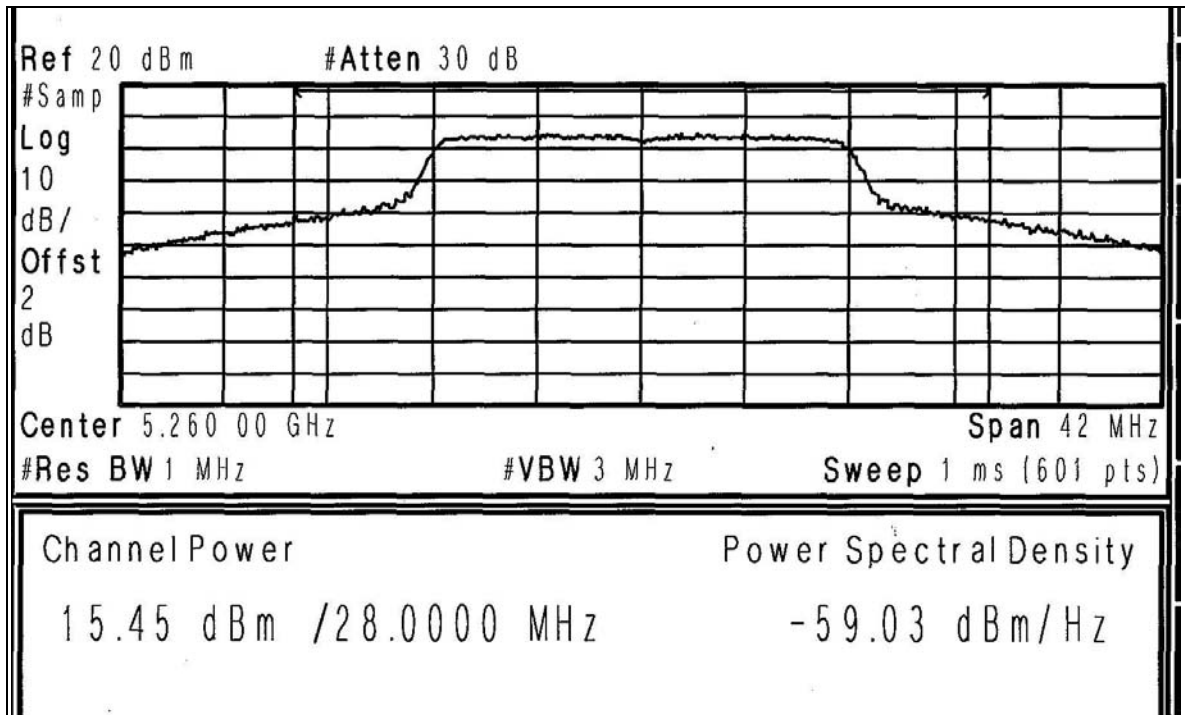

CH 8

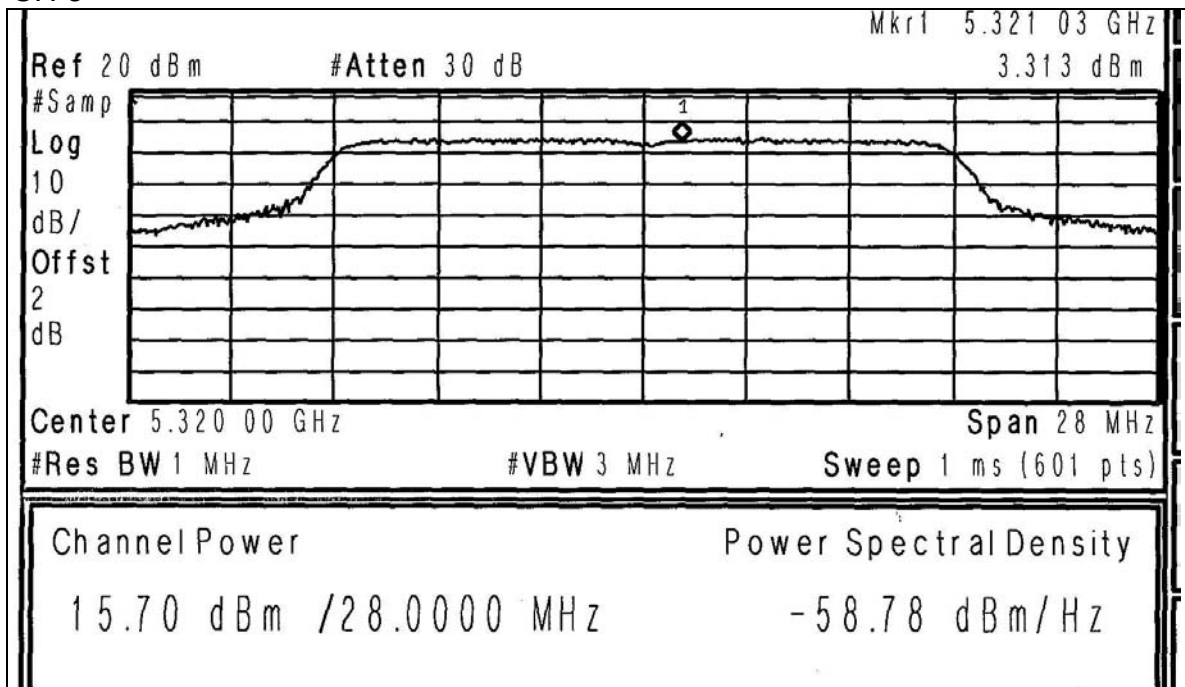



26dB Occupied Bandwidth:
CH 1

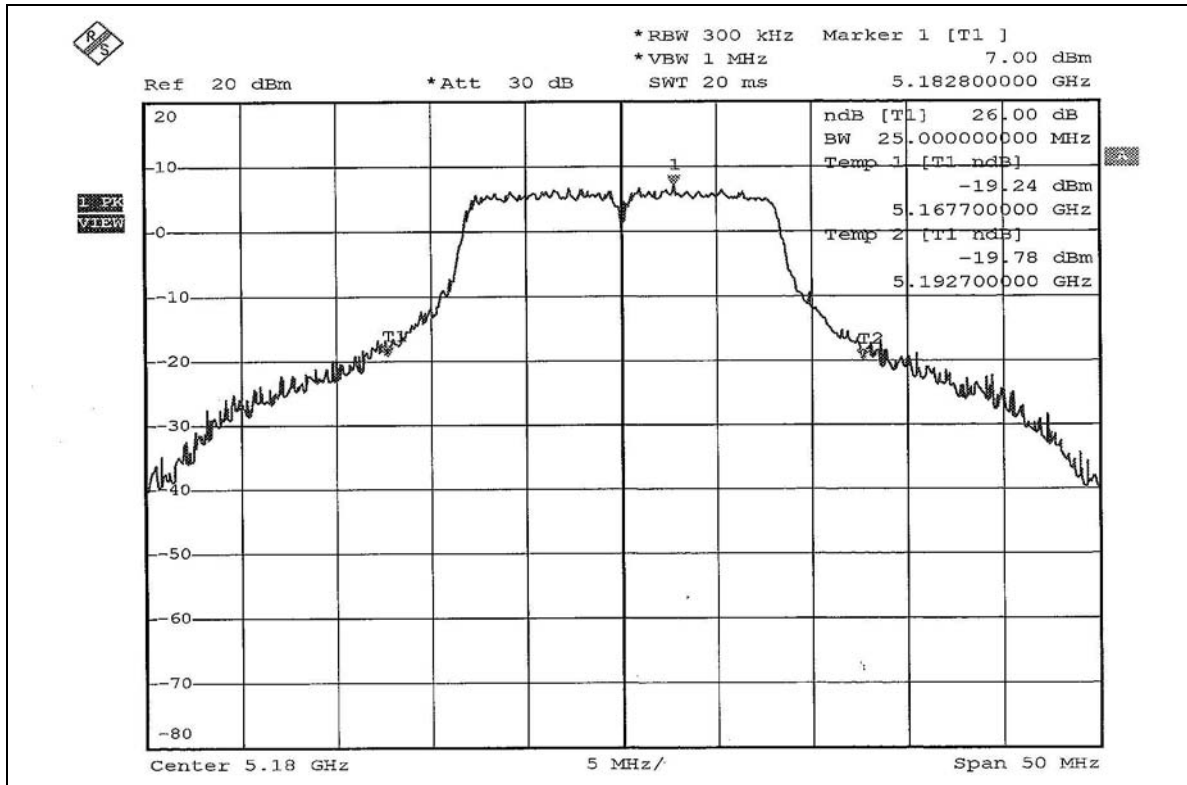

CH 4

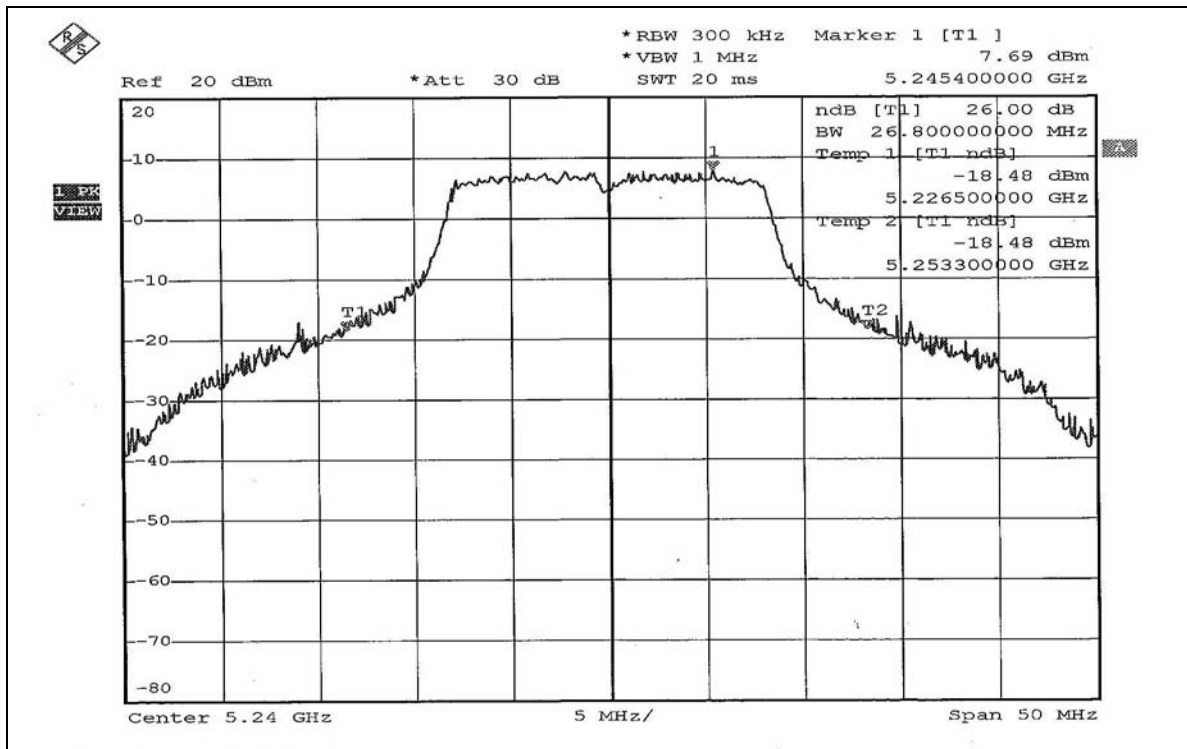



CH 5

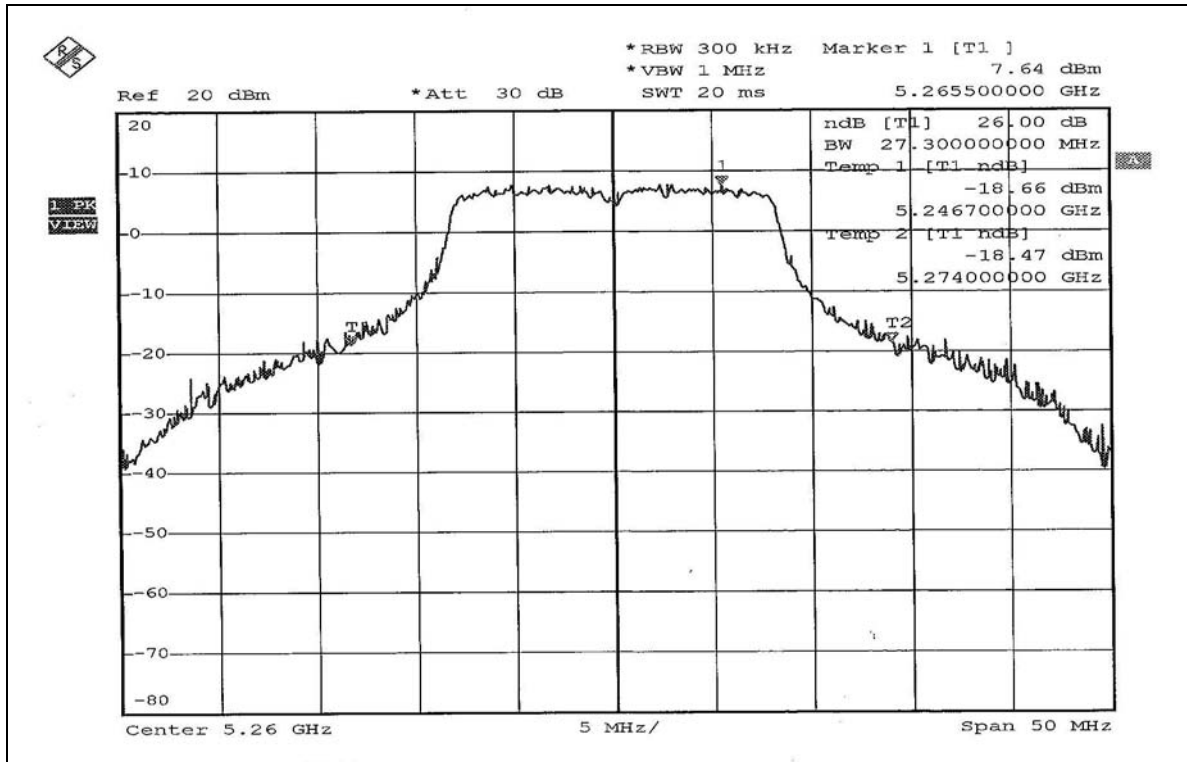

CH 8

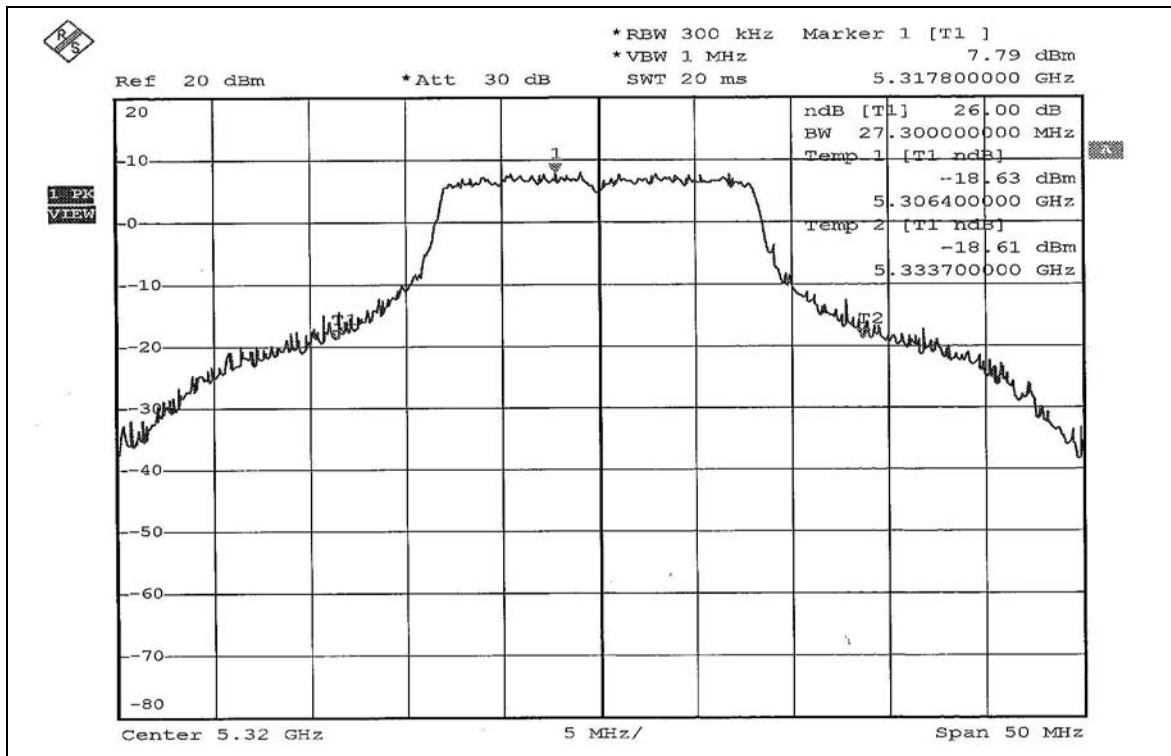

**802.11a Turbo OFDM modulation**

EUT	11a/b/g Wireless PC Card with XJACK Antenna	MODEL	SL-3050
MODULATION TYPE	BPSK	TRANSFER RATE	12Mbps
INPUT POWER (SYSTEM)	120Vac, 60 Hz	ENVIRONMENTAL CONDITIONS	24deg.C, 57%RH, 991hPa
TESTED BY	Match Tsui		

CHANNEL	CHANNEL FREQUENCY (MHz)	PEAK POWER OUTPUT (mW)	PEAK POWER OUTPUT (dBm)	PEAK POWER LIMIT (dBm)	26dBc Occupied Bandwidth (MHz)	PASS/FAIL
1	5210	32.659	15.14	17.00	45.00	PASS
2	5250	32.063	15.06	17.00	45.60	PASS
3	5290	31.915	15.04	24.00	45.20	PASS

NOTE: The 26dBc Occupied Bandwidth plot, please refer to the following pages.



Peak Power Output:

CH 1

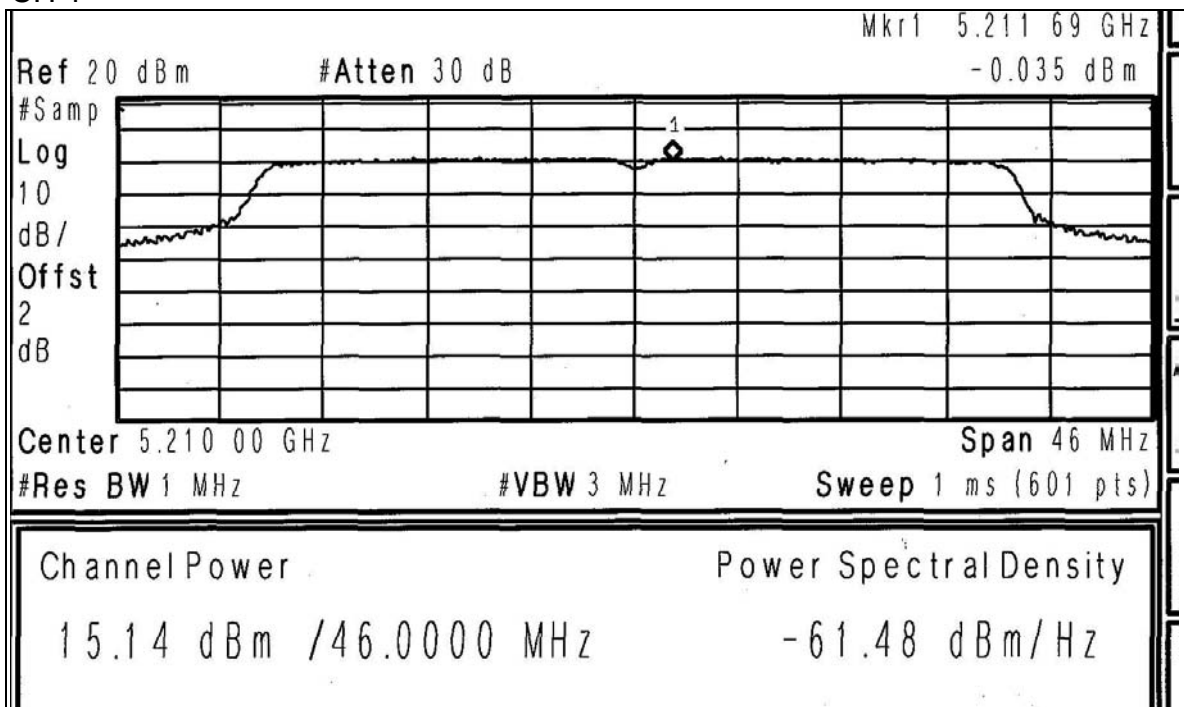

CH 2

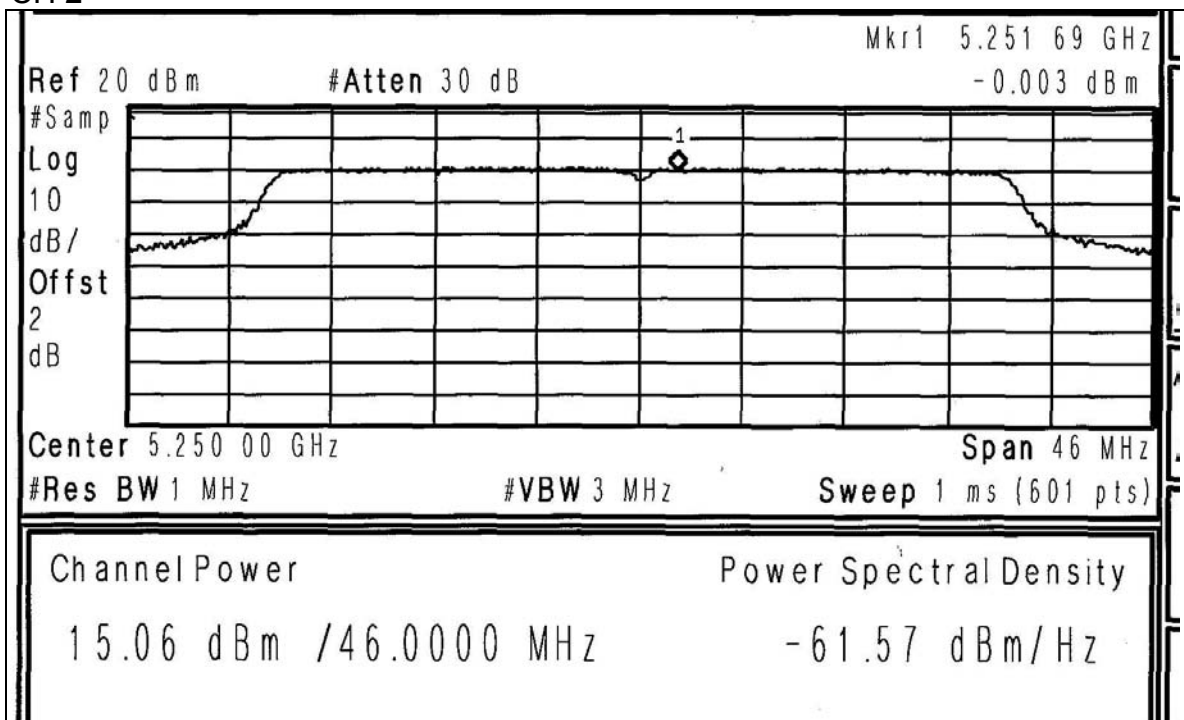



CH 3

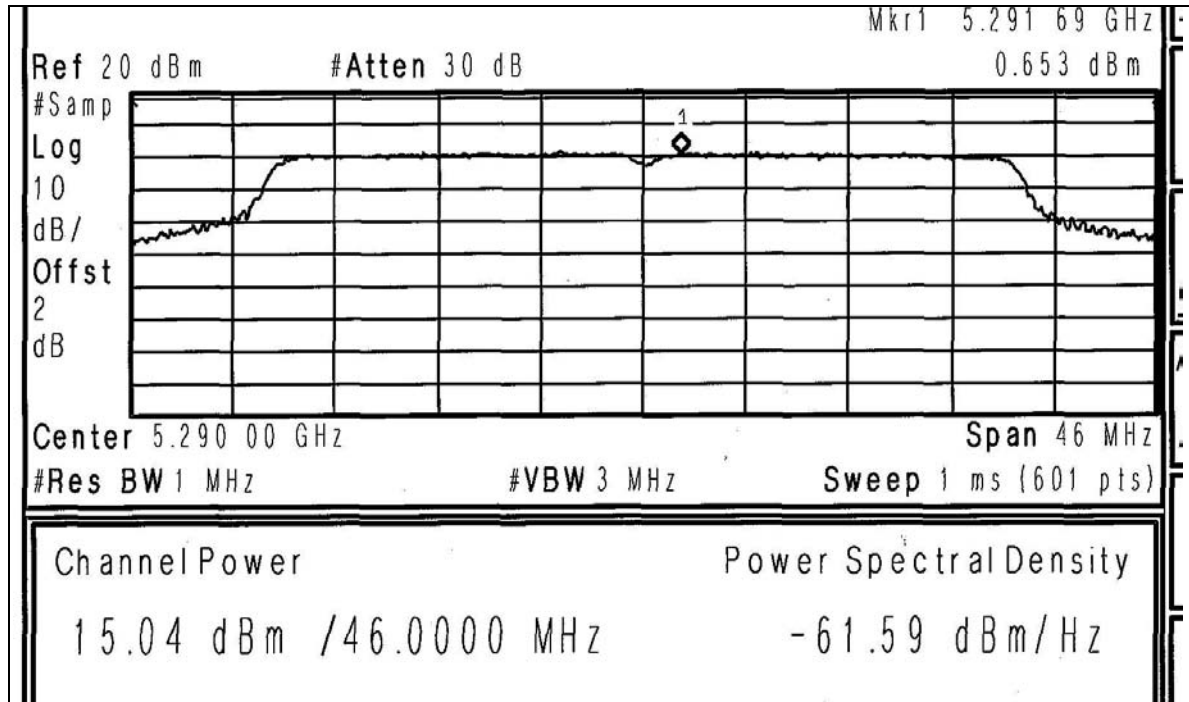



26dB Occupied Bandwidth:
CH 1

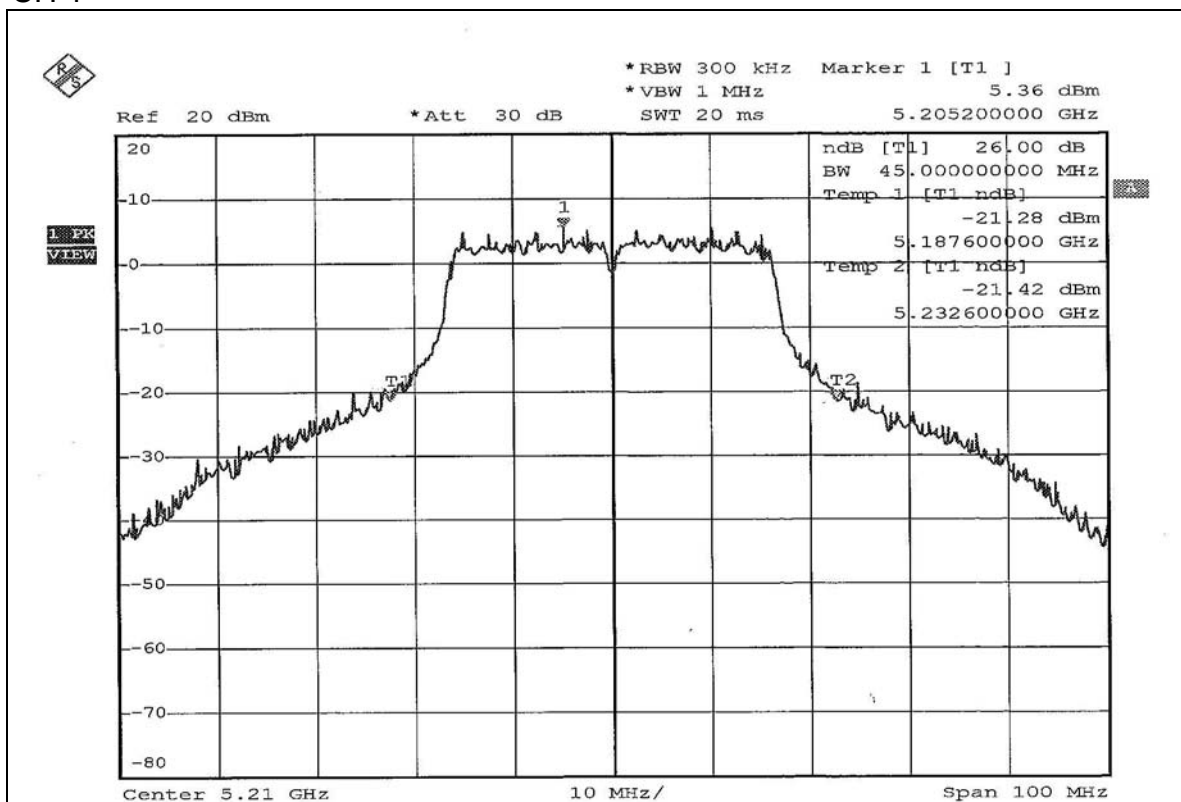

CH 2

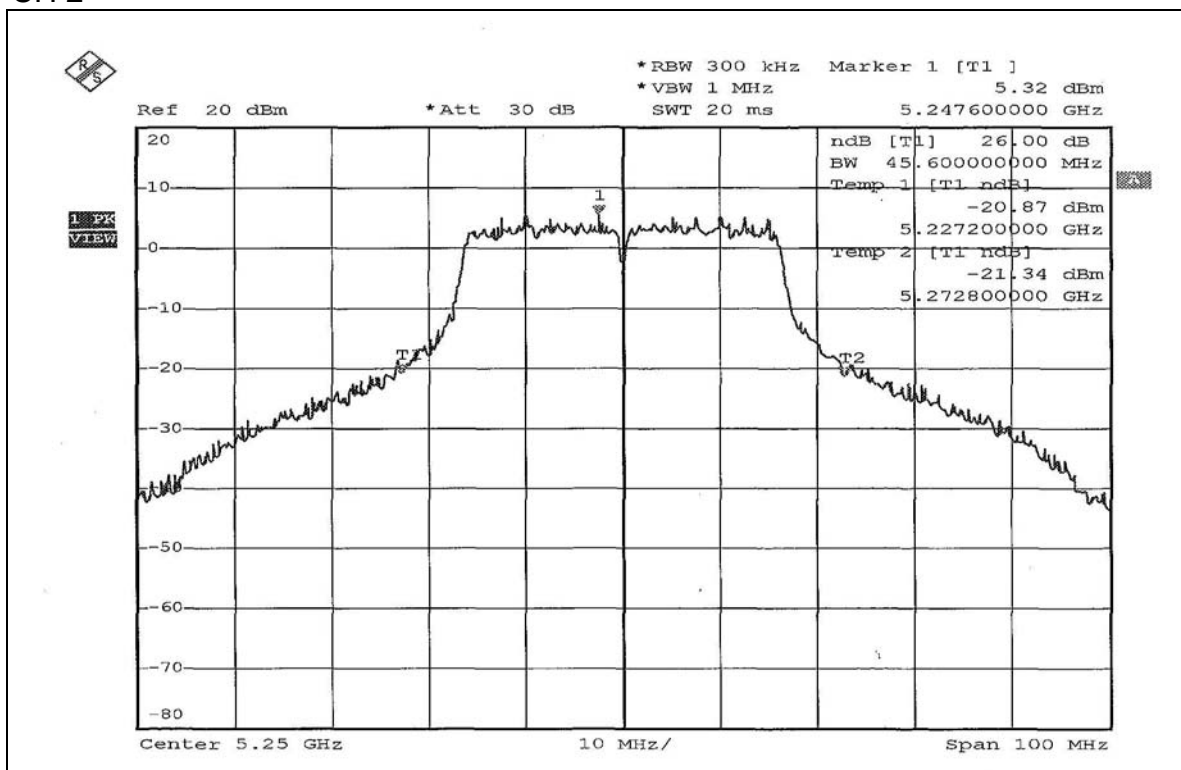



CH 3

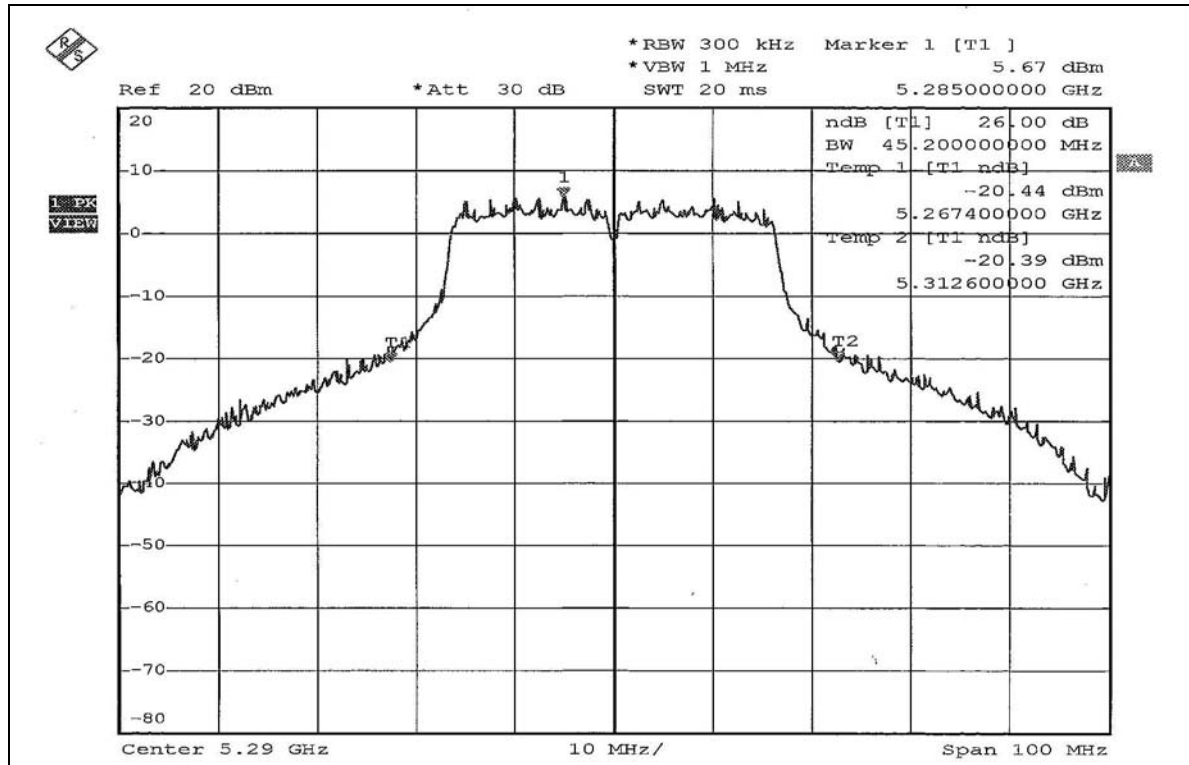



4.4 PEAK POWER EXCURSION MEASUREMENT

4.4.1 LIMITS OF PEAK POWER EXCURSION MEASUREMENT

Frequency Band	Limit
5.15 – 5.25 GHz	13dB
5.25 – 5.35 GHz	13dB
5.725 – 5.825 GHz	13dB

4.4.2 TEST INSTRUMENTS

Description & Manufacturer	Model No.	Serial No.	Calibrated Until
SPECTRUM ANALYZER	FSEK30	100049	Aug. 12, 2005

NOTE: The calibration interval of the above test instruments is 12 months and the calibrations are traceable to NML/ROC and NIST/USA.



4.4.3 TEST PROCEDURE

1. The transmitter output was connected to the spectrum analyzer.
2. Set the spectrum bandwidth span to view the entire spectrum.
3. Using peak detector and Max-hold function for Trace 1 (RB=1MHz, VB=3MHz) and 2 (RB=1MHz, VB=300KHz).
4. The largest difference between Trace 1 and Trace 2 in any 1MHz band on any frequency was recorded.

4.4.4 DEVIATION FROM TEST STANDARD

No deviation

4.4.5 TEST SETUP

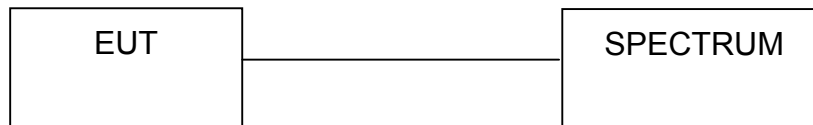

4.4.6 EUT OPERATING CONDITIONS

The software provided by client to enable the EUT under transmission condition continuously at specific channel frequencies individually.



4.4.7 TEST RESULTS

802.11a OFDM modulation

EUT	11a/b/g Wireless PC Card with XJACK Antenna	MODEL	SL-3050
MODULATION TYPE	BPSK	TRANSFER RATE	6Mbps
INPUT POWER (SYSTEM)	120Vac, 60 Hz	ENVIRONMENTAL CONDITIONS	24deg.C, 57%RH, 991hPa
TESTED BY	Match Tsui		

CHANNEL	CHANNEL FREQUENCY (MHz)	PEAK POWER EXCURSION (dB)	PEAK to AVERAGE EXCURSION LIMIT (dB)	PASS/FAIL
1	5180	7.43	13	PASS
4	5240	7.22	13	PASS
5	5260	7.16	13	PASS
8	5320	6.63	13	PASS



CH 1

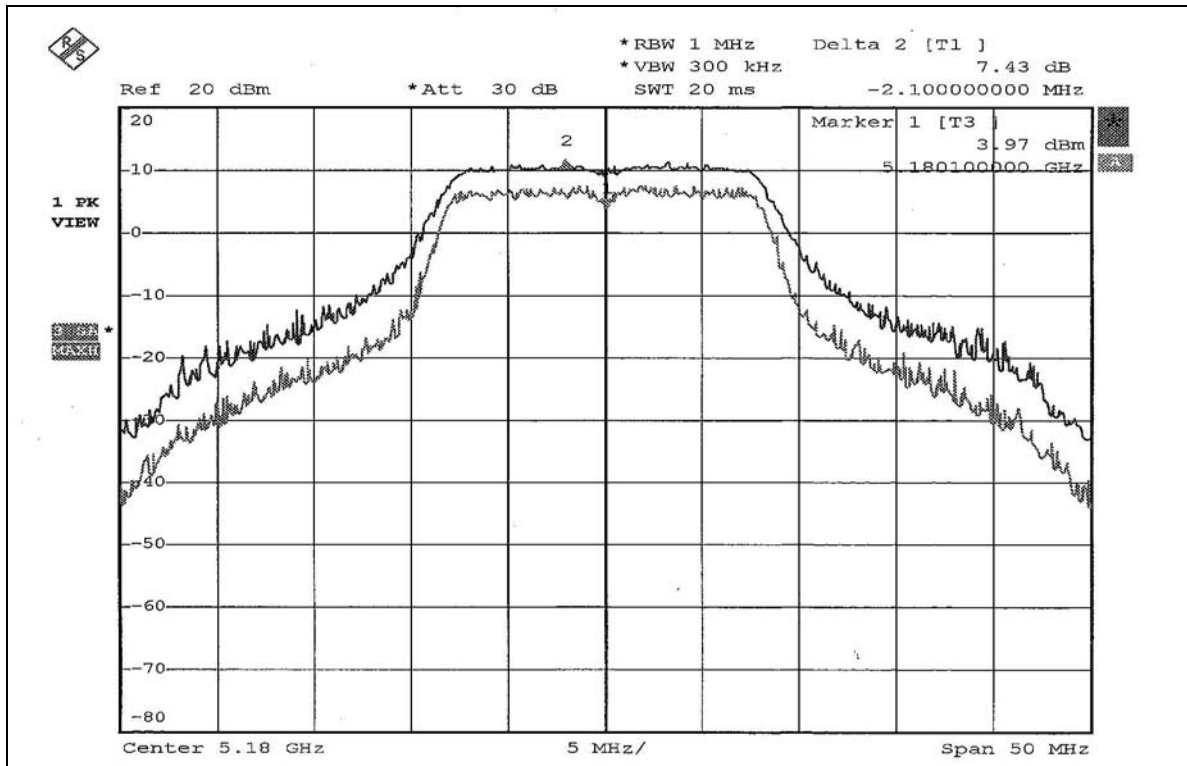

CH 4

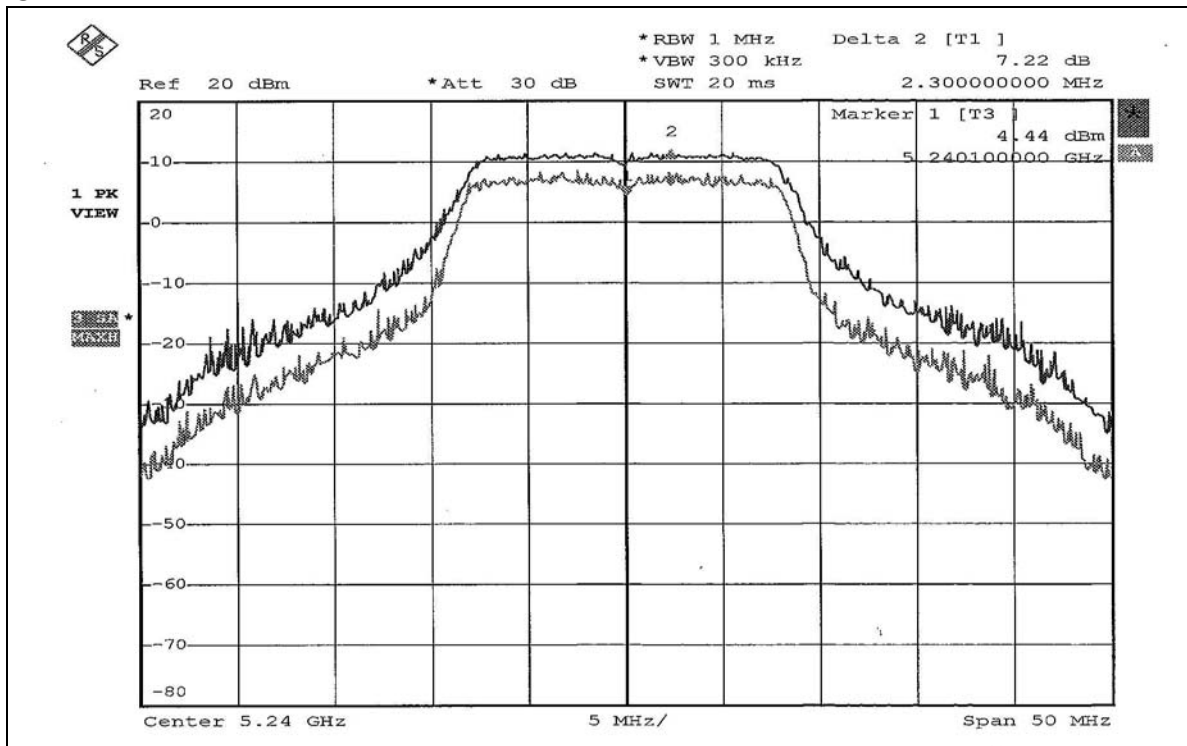



CH 5

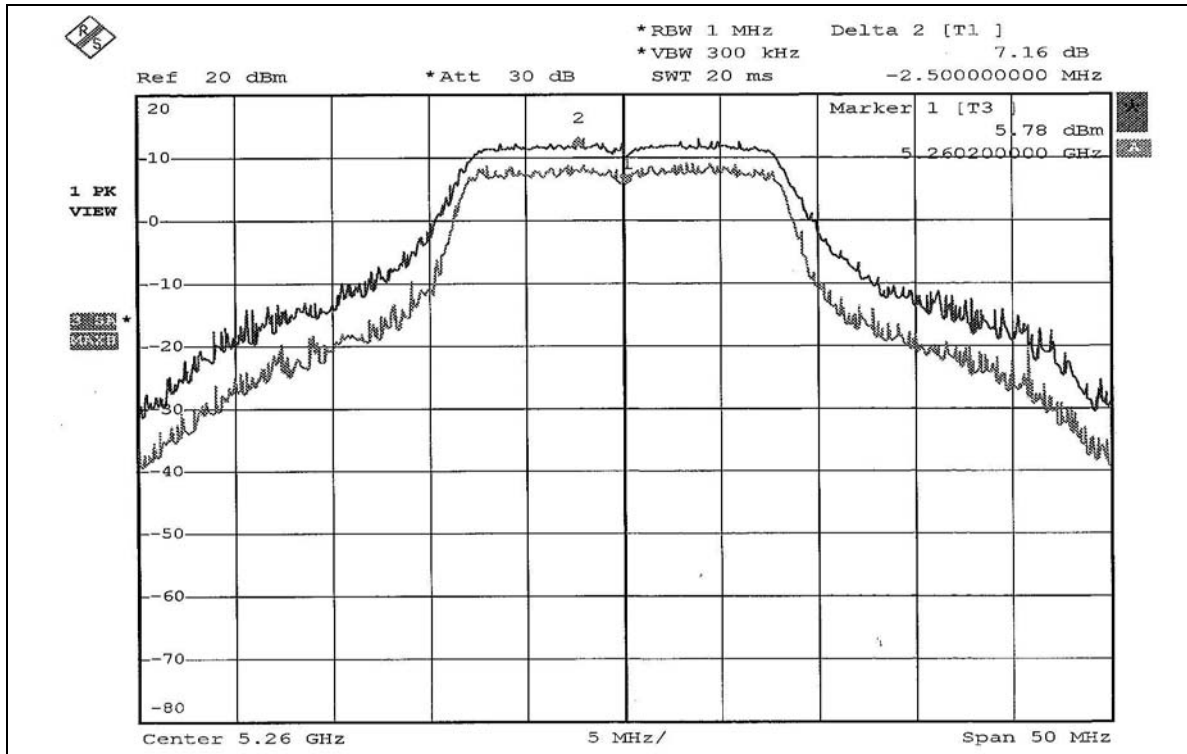

CH 8

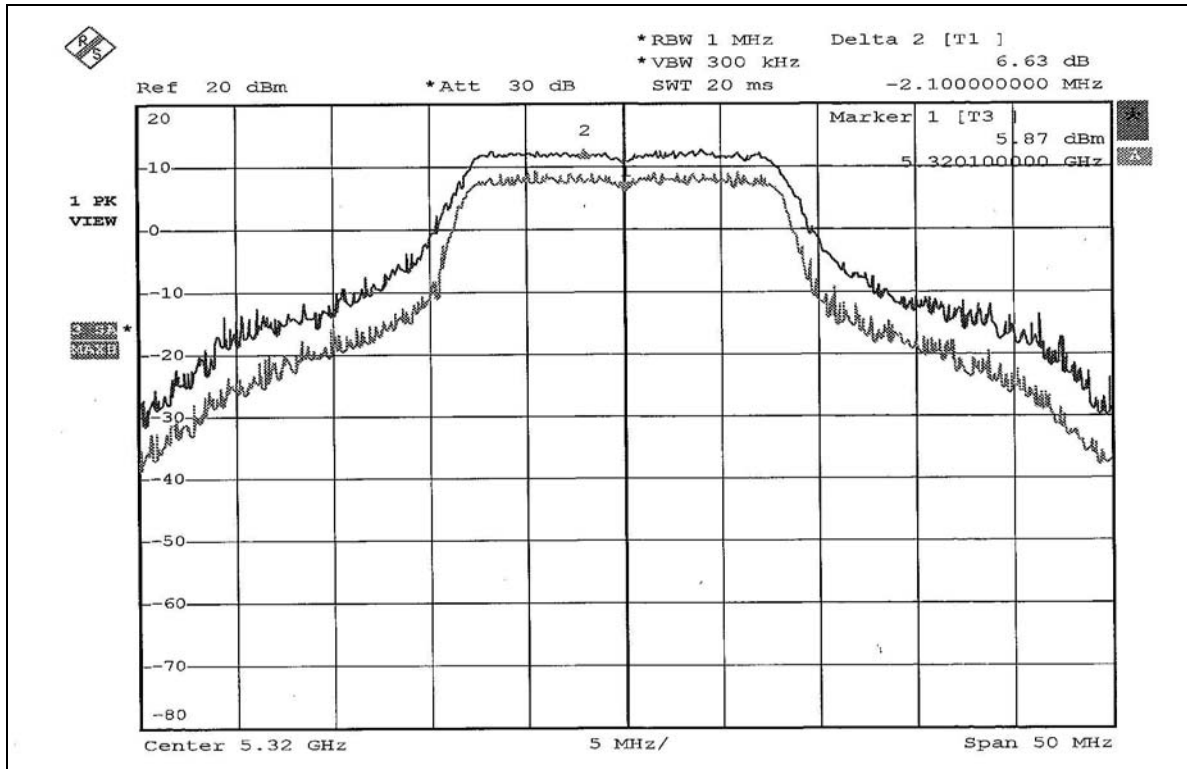

**802.11a Turbo OFDM modulation**

EUT	11a/b/g Wireless PC Card with XJACK Antenna	MODEL	SL-3050
MODULATION TYPE	BPSK	TRANSFER RATE	12Mbps
INPUT POWER (SYSTEM)	120Vac, 60 Hz	ENVIRONMENTAL CONDITIONS	24deg.C, 57%RH, 991hPa
TESTED BY	Match Tsui		

CHANNEL	CHANNEL FREQUENCY (MHz)	PEAK POWER EXCURSION (dB)	PEAK to AVERAGE EXCURSION LIMIT (dB)	PASS/FAIL
1	5210	9.13	13	PASS
2	5250	8.17	13	PASS
3	5290	7.57	13	PASS



CH 1

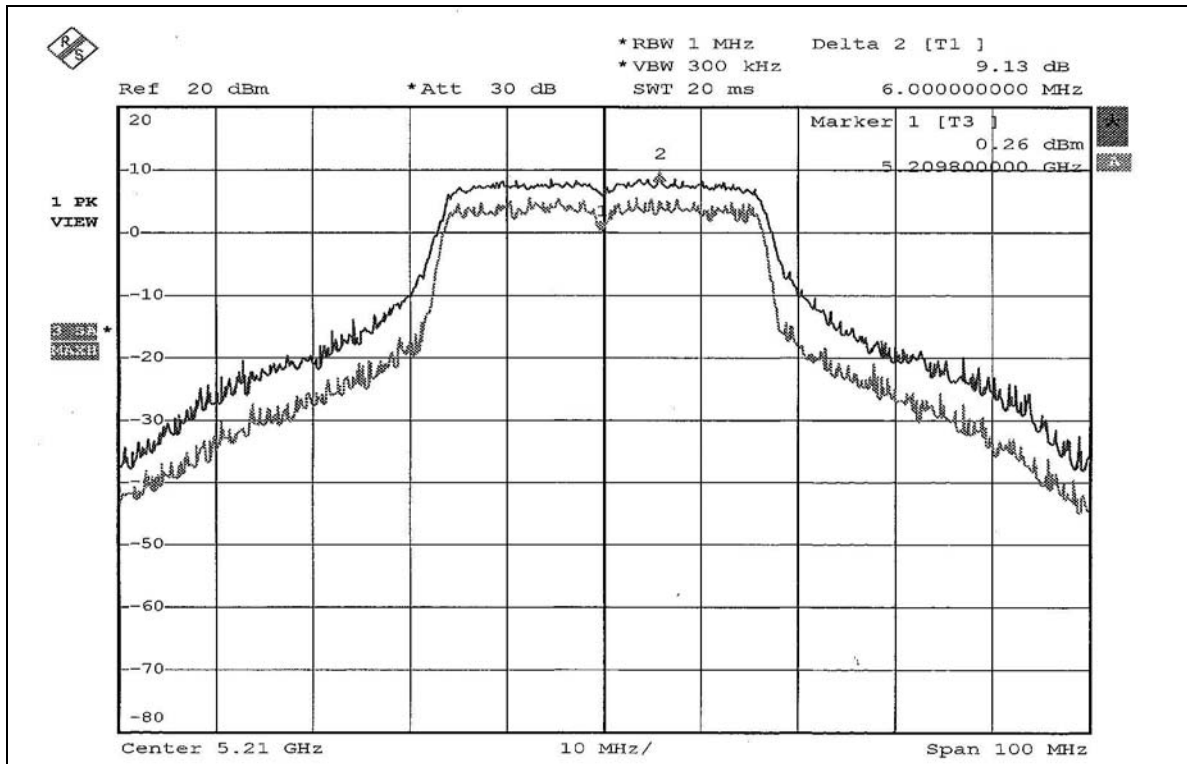

CH 2

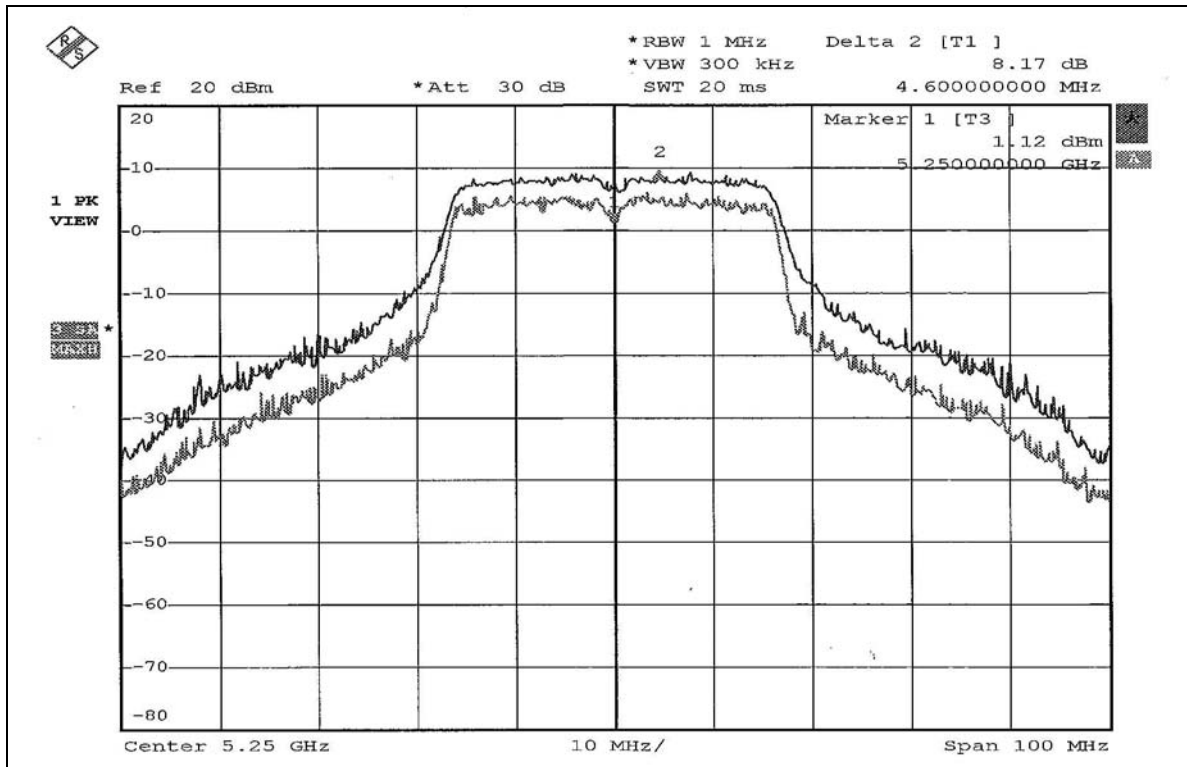



CH 3

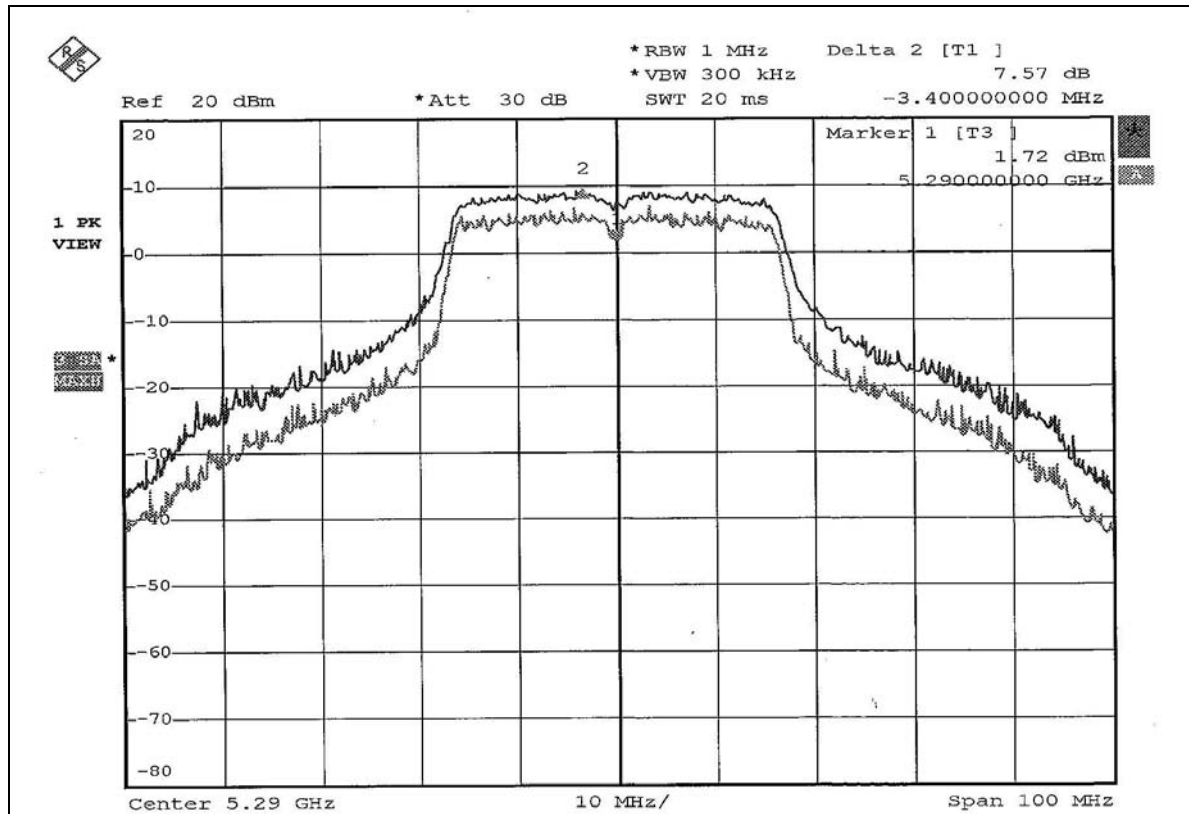



4.5 PEAK POWER SPECTRAL DENSITY MEASUREMENT

4.5.1 LIMITS OF PEAK POWER SPECTRAL DENSITY MEASUREMENT

Frequency Band	Limit
5.15 ~ 5.25GHz	4dBm
5.25 ~ 5.35GHz	11dBm
5.725 ~ 5.825GHz	17dBm

4.5.2 TEST INSTRUMENTS

Description & Manufacturer	Model No.	Serial No.	Calibrated Until
SPECTRUM ANALYZER	FSEK30	100049	Aug. 12, 2005

NOTE: The calibration interval of the above test instruments is 12 months and the calibrations are traceable to NML/ROC and NIST/USA.

4.5.3 TEST PROCEDURES

1. The transmitter output was connected to the spectrum analyzer.
2. Set RBW=1MHz, VBW=3MHz. The PPSD is the highest level found across the emission in any 1MHz band.

4.5.4 DEVIATION FROM TEST STANDARD

No deviation

4.5.5 TEST SETUP

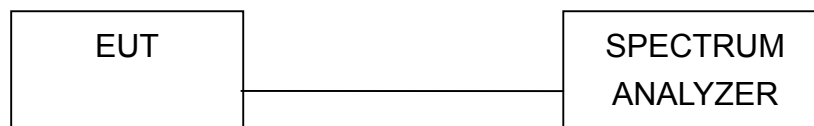

4.5.6 EUT OPERATING CONDITIONS

Same as 5.3.6



4.5.7 TEST RESULTS

802.11a OFDM modulation

EUT	11a/b/g Wireless PC Card with XJACK Antenna	MODEL	SL-3050
MODULATION TYPE	BPSK	TRANSFER RATE	6Mbps
INPUT POWER (SYSTEM)	120Vac, 60 Hz	ENVIRONMENTAL CONDITIONS	24deg.C, 57%RH, 991hPa
TESTED BY	Match Tsui		

CHANNEL	CHANNEL FREQUENCY (MHz)	RF POWER LEVEL IN 1MHz BW (dBm)	MAXIMUM LIMIT (dBm)	PASS/FAIL
1	5180	1.32	4	PASS
4	5240	1.22	4	PASS
5	5260	3.13	11	PASS
8	5320	3.69	11	PASS



CH 1

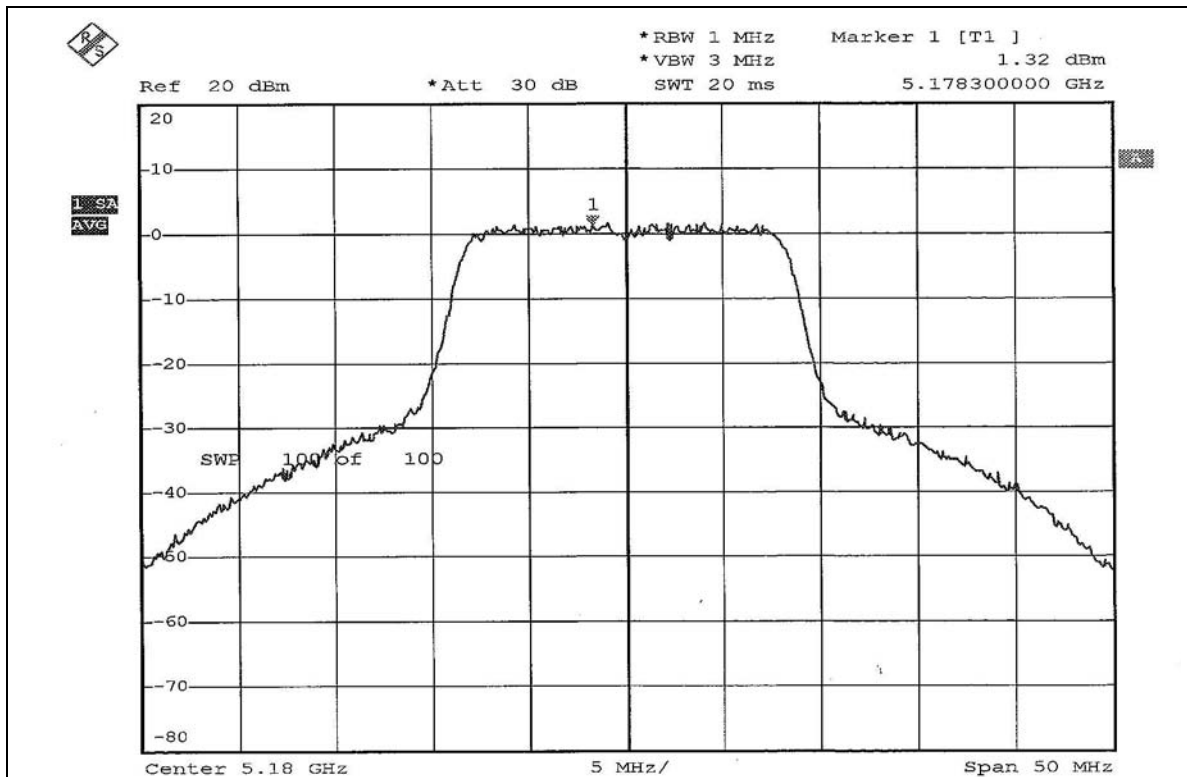

CH 4

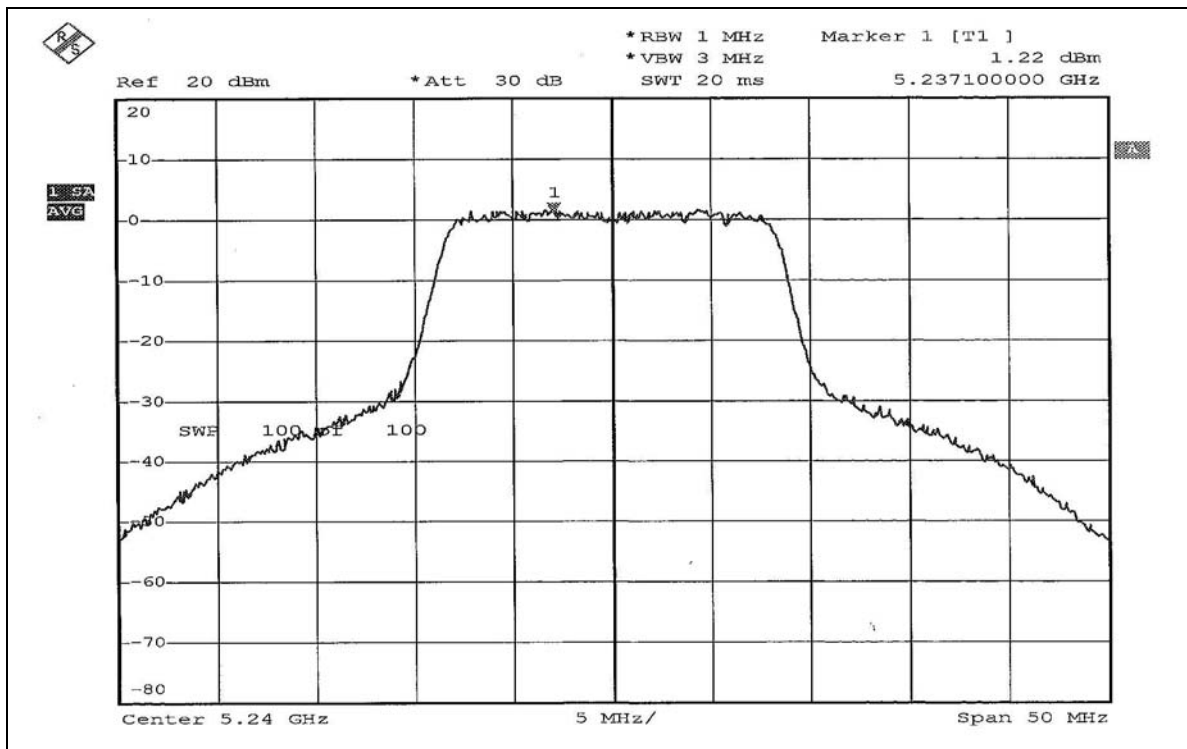



CH 5

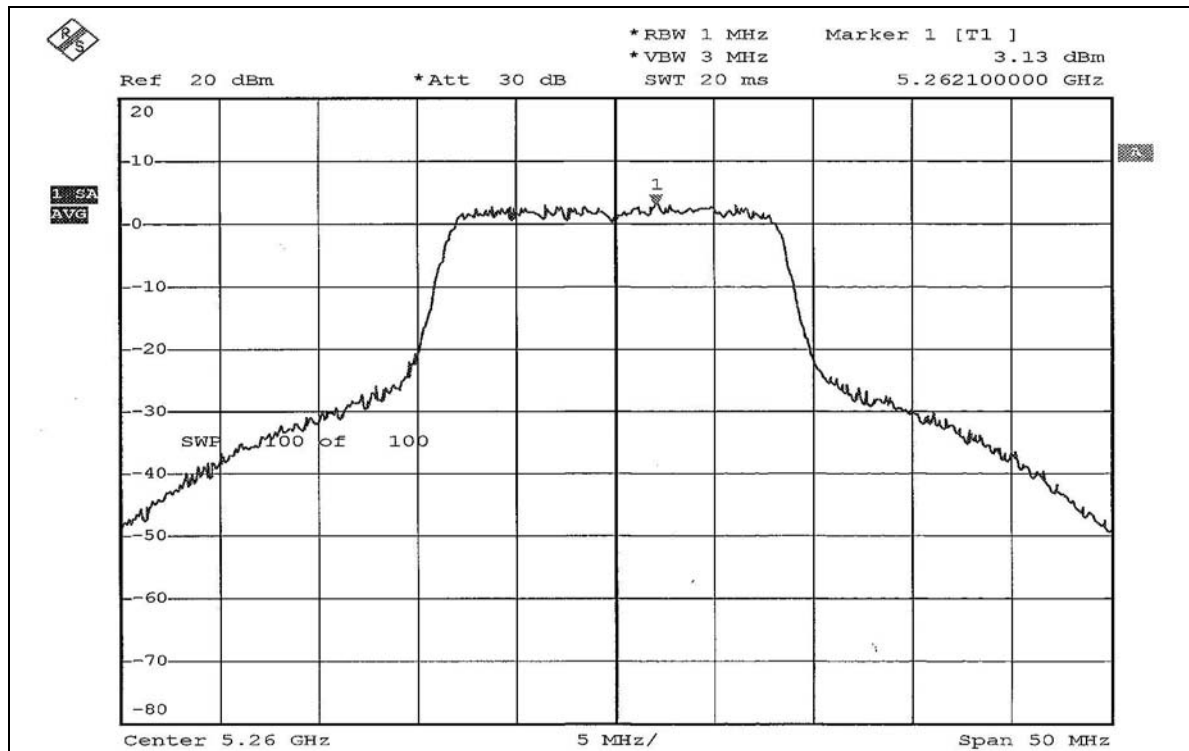

CH 8

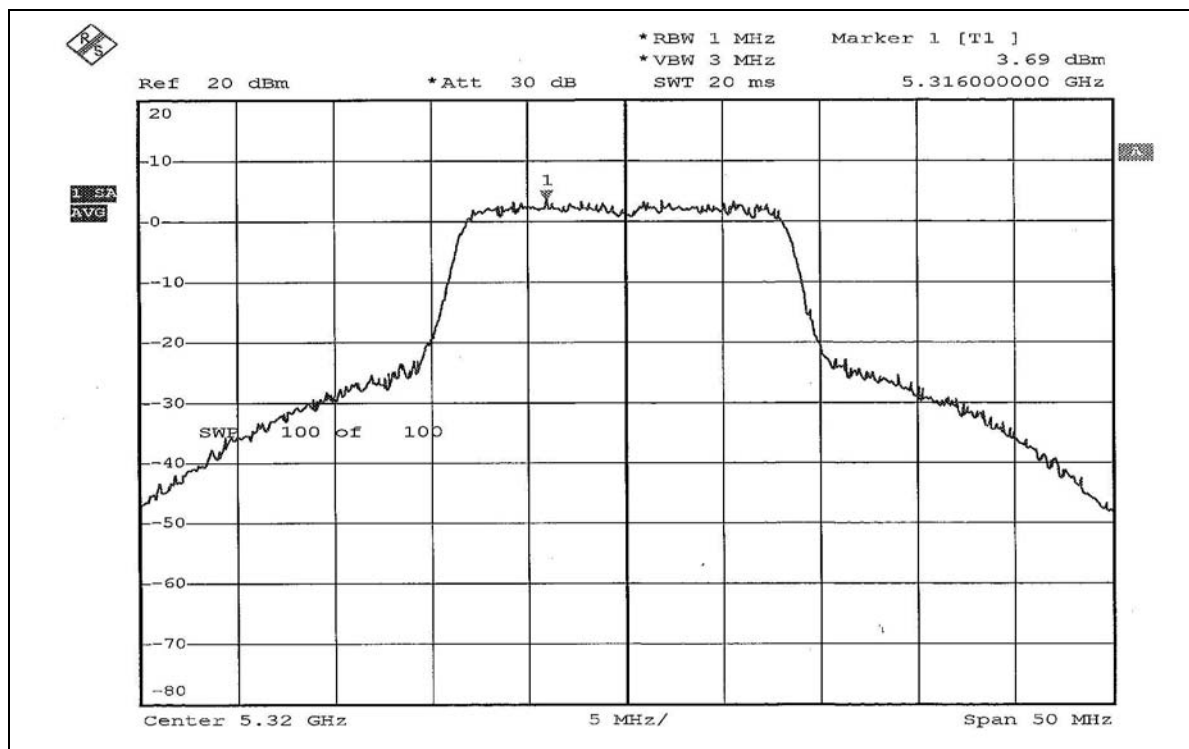

**802.11a Turbo OFDM modulation**

EUT	11a/b/g Wireless PC Card with XJACK Antenna	MODEL	SL-3050
MODULATION TYPE	BPSK	TRANSFER RATE	12Mbps
INPUT POWER (SYSTEM)	120Vac, 60 Hz	ENVIRONMENTAL CONDITIONS	24deg.C, 57%RH, 991hPa
TESTED BY	Match Tsui		

CHANNEL	CHANNEL FREQUENCY (MHz)	RF POWER LEVEL IN 1 MHz BW (dBm)	MAXIMUM LIMIT (dBm)	PASS/FAIL
1	5210	-0.49	4	PASS
2	5250	-0.19	11	PASS
3	5290	-0.17	11	PASS



CH 1

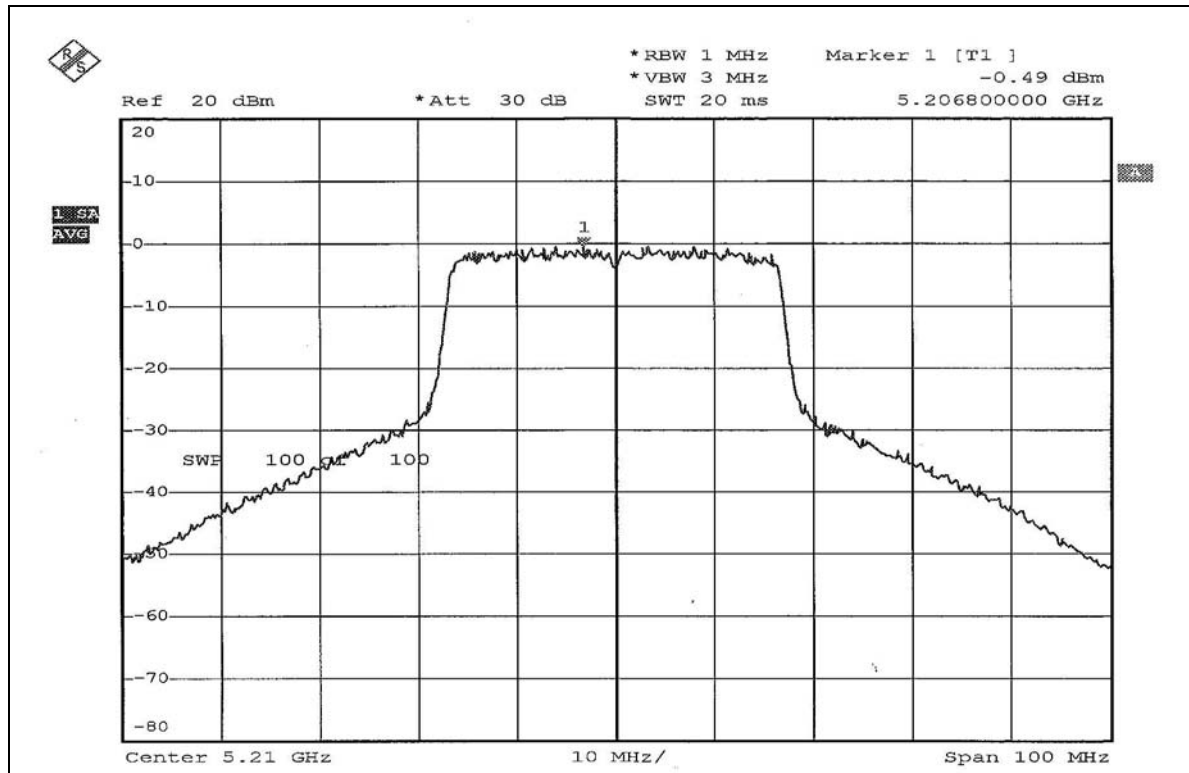

CH 2

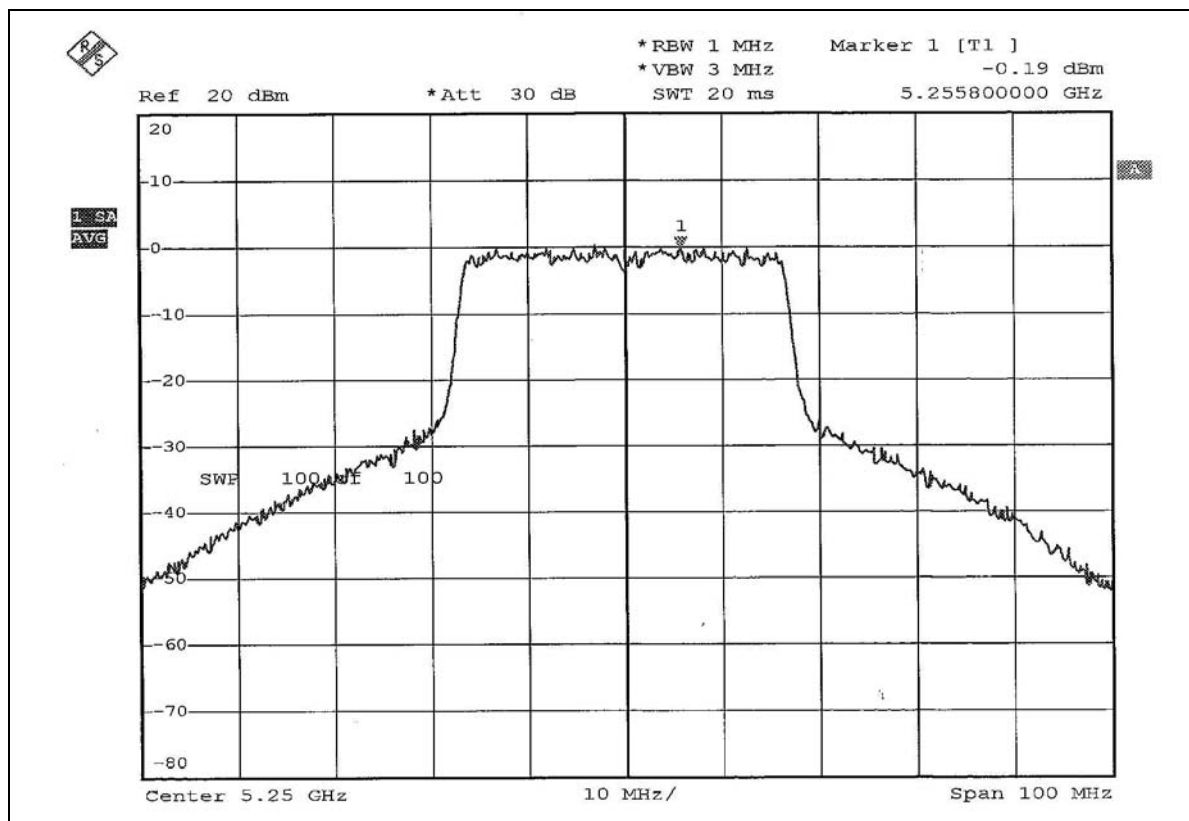



CH 3

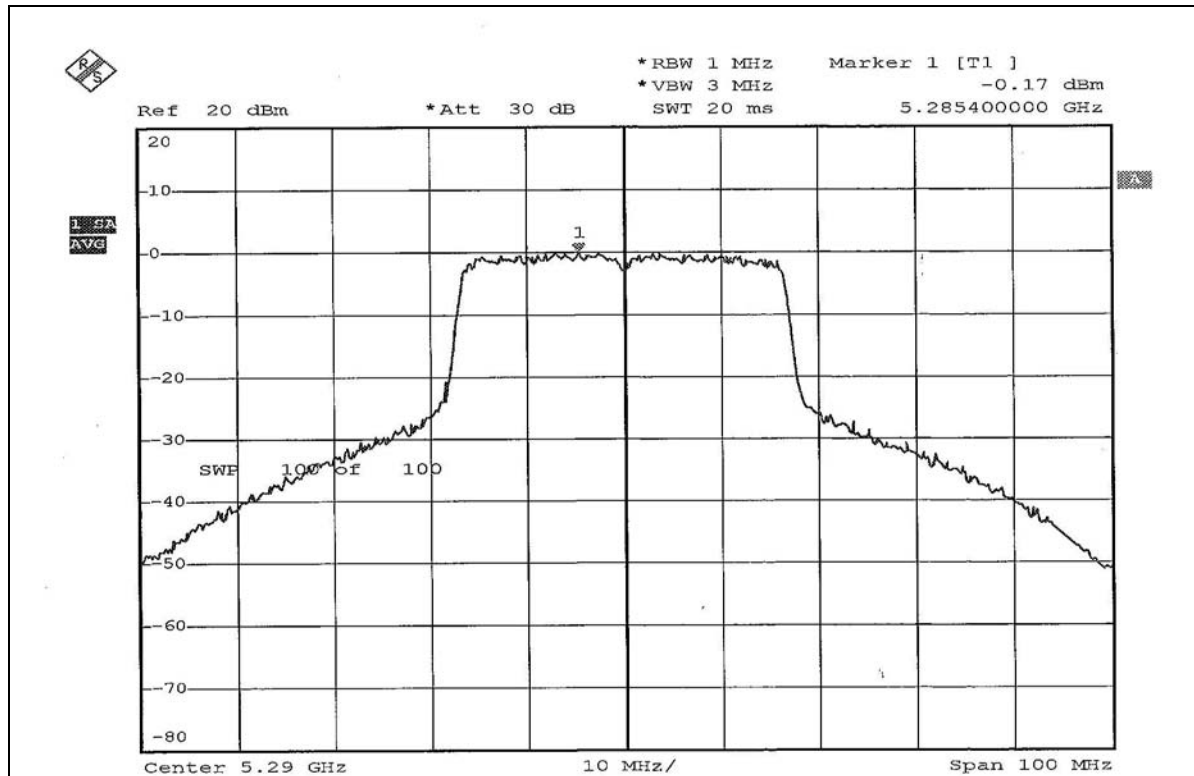



4.6 FREQUENCY STABILITY

4.6.1 LIMITS OF FREQUENCY STABILITY MEASUREMENT

The frequency tolerance of the carrier signal shall be maintained within +/- 0.02% of the operating frequency over a temperature variation of -30 degrees to 50 degrees C at normal supply voltage, and for a variation in the primary supply voltage from 85% to 115% of the rated supply voltage at a temperature of 20 degrees C.

4.6.2 TEST INSTRUMENTS

Description & Manufacturer	Model No.	Serial No.	Calibrated Until
ANRITSU SPECTRUM ANALYZER	MS2667C	M10281	Aug. 12, 2005
WIT STANDARD TEMPERATURE AND HUMIDITY CHAMBER	TH-4S-C	W901030	Aug. 12, 2005

NOTE: The calibration interval of the above test instruments is 12 months and the calibrations are traceable to NML/ROC and NIST/USA.

4.6.3 TEST PROCEDURE

1. The EUT was placed inside the environmental test chamber and powered by nominal DC voltage.
2. Turn the EUT on and couple its output to a spectrum analyzer.
3. Turn the EUT off and set the chamber to the highest temperature specified.
4. Allow sufficient time (approximately 30 min) for the temperature of the chamber to stabilize, turn the EUT on and measure the operating frequency after 2, 5, and 10 minutes.
5. Repeat step 2 and 3 with the temperature chamber set to the lowest temperature.
6. The test chamber was allowed to stabilize at +20 degree C for a minimum of 30 minutes. The supply voltage was then adjusted on the EUT from 85% to 115% and the frequency record.

4.6.4 DEVIATION FROM TEST STANDARD

No deviation

4.6.5 TEST SETUP

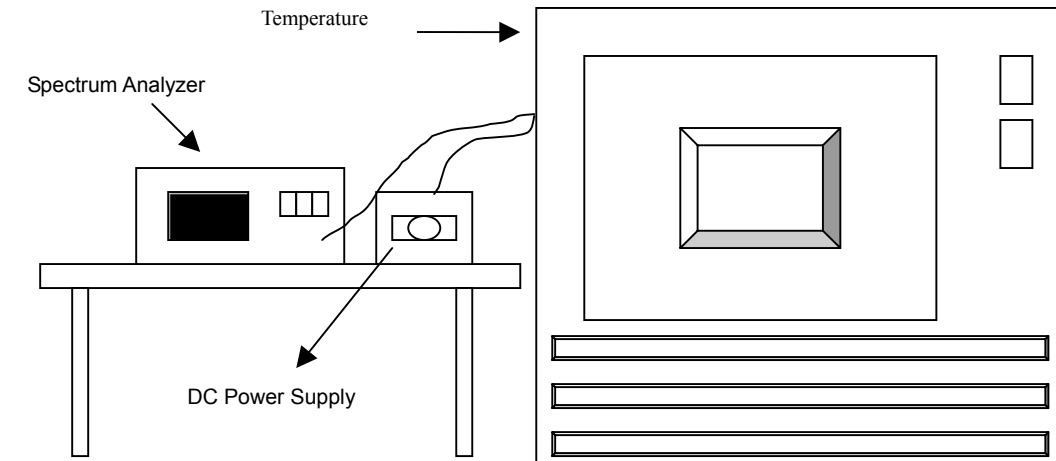

4.6.6 EUT OPERATING CONDITION

Same as Item 4.3.6



4.6.7 TEST RESULTS

		Operating frequency: 5320MHz				Limit : ± 0.015%			
Temp. (°C)	Power supply (Vac)	0 minute		2 minute		5 minute		10 minute	
		(MHz)	(%)	(MHz)	(%)	(MHz)	(%)	(MHz)	(%)
50	138	5320.0451	0.0008477	5320.0455	0.0008553	5320.0457	0.0008590	5320.0461	0.0008665
	120	5320.0455	0.0008553	5320.0452	0.0008496	5320.0451	0.0008477	5320.0465	0.0008741
	102	5320.0456	0.0008571	5320.0459	0.0008628	5320.0458	0.0008609	5320.0467	0.0008778
40	138	5320.0391	0.0007350	5320.0395	0.0007425	5320.0391	0.0007350	5320.0394	0.0007406
	120	5320.0392	0.0007368	5320.0394	0.0007406	5320.0395	0.0007425	5320.0396	0.0007444
	102	5320.0395	0.0007425	5320.0390	0.0007331	5320.0397	0.0007462	5320.0392	0.0007368
30	138	5320.0322	0.0006053	5320.0325	0.0006109	5320.0330	0.0006203	5320.0327	0.0006147
	120	5320.0321	0.0006034	5320.0321	0.0006034	5320.0331	0.0006222	5320.0324	0.0006090
	102	5320.0324	0.0006090	5320.0326	0.0006128	5320.0324	0.0006090	5320.0326	0.0006128
20	138	5320.0275	0.0005169	5320.0271	0.0005094	5320.0271	0.0005094	5320.0268	0.0005038
	120	5320.0271	0.0005094	5320.0276	0.0005188	5320.0276	0.0005188	5320.0264	0.0004962
	102	5320.0275	0.0005169	5320.0274	0.0005150	5320.0279	0.0005244	5320.0265	0.0004981
10	138	5320.0192	0.0003609	5320.0172	0.0003233	5320.0175	0.0003289	5320.0173	0.0003252
	120	5320.0195	0.0003665	5320.0176	0.0003308	5320.0172	0.0003233	5320.0176	0.0003308
	102	5320.0192	0.0003609	5320.0177	0.0003327	5320.0176	0.0003308	5320.0178	0.0003346
0	138	5320.0125	0.0002350	5320.0119	0.0002237	5320.0118	0.0002218	5320.0116	0.0002180
	120	5320.0121	0.0002274	5320.0121	0.0002274	5320.0111	0.0002086	5320.0115	0.0002162
	102	5320.0124	0.0002331	5320.0122	0.0002293	5320.0115	0.0002162	5320.0117	0.0002199
-10	138	5320.0012	0.0000226	5320.0010	0.0000188	5320.0015	0.0000282	5320.0017	0.0000320
	120	5320.0013	0.0000244	5320.0014	0.0000263	5320.0015	0.0000282	5320.0014	0.0000263
	102	5320.0018	0.0000338	5320.0015	0.0000282	5320.0012	0.0000226	5320.0012	0.0000226
-20	138	5319.9921	-0.0001485	5319.9920	-0.0001504	5319.9927	-0.0001372	5319.9924	-0.0001429
	120	5319.9925	-0.0001410	5319.9921	-0.0001485	5319.9925	-0.0001410	5319.9927	-0.0001372
	102	5319.9919	-0.0001523	5319.9924	-0.0001429	5319.9921	-0.0001485	5319.9924	-0.0001429
-30	138	5319.9782	-0.0004098	5319.9785	-0.0004041	5319.9782	-0.0004098	5319.9785	-0.0004041
	120	5319.9781	-0.0004117	5319.9784	-0.0004060	5319.9789	-0.0003966	5319.9786	-0.0004023
	102	5319.9785	-0.0004041	5319.9782	-0.0004098	5319.9784	-0.0004060	5319.9781	-0.0004117



4.7 BAND EDGES MEASUREMENT

4.7.1 TEST INSTRUMENTS

Description & Manufacturer	Model No.	Serial No.	Calibrated Until
SPECTRUM ANALYZER	FSEK30	100049	Aug. 12, 2005

NOTE: The calibration interval of the above test instruments is 12 months and the calibrations are traceable to NML/ROC and NIST/USA.

4.7.2 TEST PROCEDURE

The transmitter output was connected to the spectrum analyzer via a low lose cable. Set both RBW and VBW of spectrum analyzer to 1MHz with suitable frequency span including 100 MHz bandwidth from band edge. The band edges was measured and recorded.

4.7.3 EUT OPERATING CONDITION

The software provided by client to enable the EUT under transmission condition continuously at specific channel frequencies individually.

4.7.4 TEST RESULTS

For signals in the restricted bands above and below the 5.15 to 5.35GHz allocated band a measurement was made of the amplitude of the spurious emissions with respect to the intentional signals. The relative amplitude, in dBc, was applied to the average and peak filed strength of the intentional signal made on the OATS to calculate the field strength of the unintentional signals.

The spectrum plots (Peak RBW=VBW=1MHz; Average RBW=1MHz, VBW=10Hz) are attached on the following pages.

**802.11a OFDM modulation**

Channel 1 (5180MHz)

The band edge emission plot on page 67 shows 46.11dBc between carrier maximum power and local maximum emission in restrict band. The emission of carrier strength list in the test result of channel 1 is 106.46dBuV/m (Peak), so the maximum field strength in restrict band is $106.46-46.11=60.35$ dBuV/m which is under 74dBuV/m limit.

The band edge emission plot on page 67 shows 54.72dBc between carrier maximum power and local maximum emission in restrict band. The emission of carrier strength list in the test result of channel 1 is 96.96dBuV/m (Average), so the maximum field strength in restrict band is $96.96-54.72=42.24$ dBuV/m which is under 54dBuV/m limit.

Channel 8 (5320MHz)

The band edge emission plot on page 68 shows 44.90dBc between carrier maximum power and local maximum emission in restrict band. The emission of carrier strength list in the test result of channel 8 is 105.42dBuV/m (Peak), so the maximum field strength in restrict band is $105.42-44.90=60.52$ dBuV/m which is under 74dBuV/m limit.

The band edge emission plot on page 69 shows 54.47dBc between carrier maximum power and local maximum emission in restrict band. The emission of carrier strength list in the test result of channel 8 is 96.42dBuV/m (Average), so the maximum field strength in restrict band is $96.42-54.47=41.95$ dBuV/m which is under 54dBuV/m limit.



802.11a Turbo OFDM modulation

Channel 1 (5210MHz)

The band edge emission plot on page 70 shows 47.17dBc between carrier maximum power and local maximum emission in restrict band. The emission of carrier strength list in the test result of channel 1 is 101.51dBuV/m (Peak), so the maximum field strength in restrict band is $101.51-47.17=54.34$ dBuV/m which is under 74dBuV/m limit.

The band edge emission plot on page 70 shows 53.06dBc between carrier maximum power and local maximum emission in restrict band. The emission of carrier strength list in the test result of channel 1 is 92.40dBuV/m (Average), so the maximum field strength in restrict band is $92.40-53.06=39.34$ dBuV/m which is under 54dBuV/m limit.

Channel 3 (5290MHz)

The band edge emission plot on the pages 71 shows 48.51dBc between carrier maximum power and local maximum emission in restrict band. The emission of carrier strength list in the test result of channel 3 is 101.62dBuV/m (Peak), so the maximum field strength in restrict band is $101.62-48.51=53.11$ dBuV/m which is under 74dBuV/m limit.

The band edge emission plot on the pages 72 shows 53.75dBc between carrier maximum power and local maximum emission in restrict band. The emission of carrier strength list in the test result of channel 3 is 92.62dBuV/m (Average), so the maximum field strength in restrict band is $92.62-53.75=38.87$ dBuV/m which is under 54dBuV/m limit.



802.11a OFDM modulation

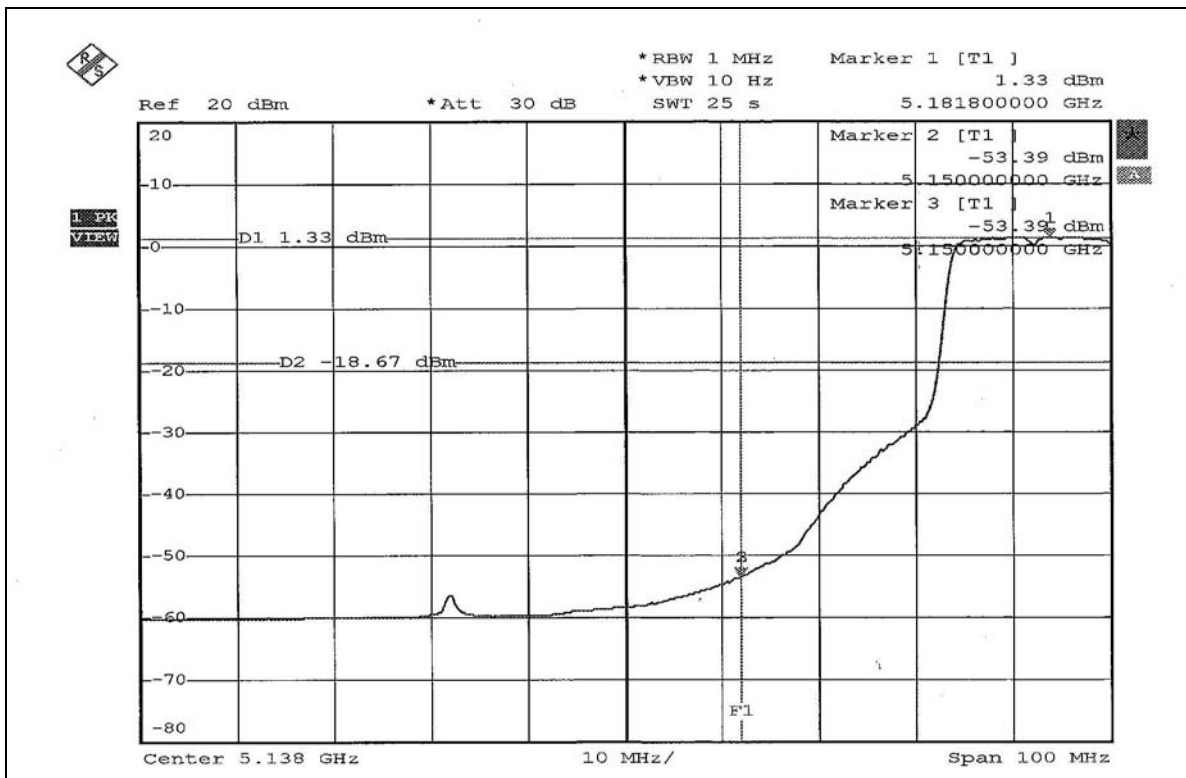
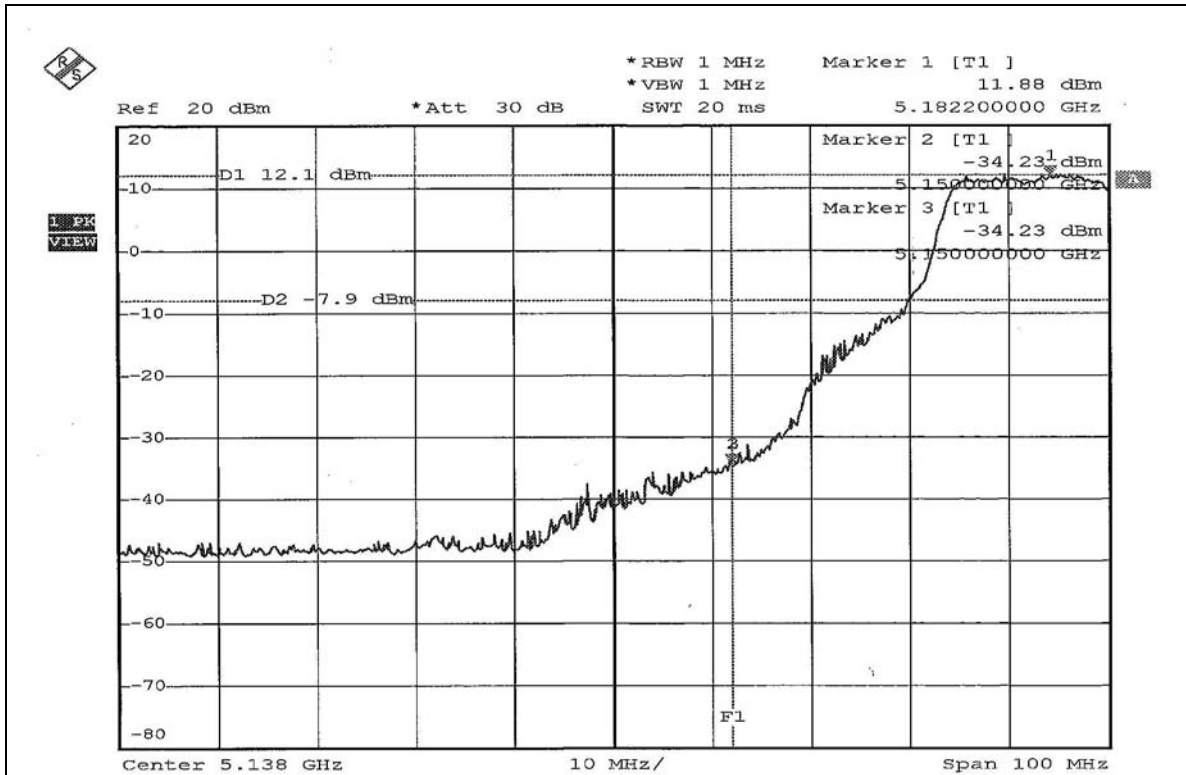

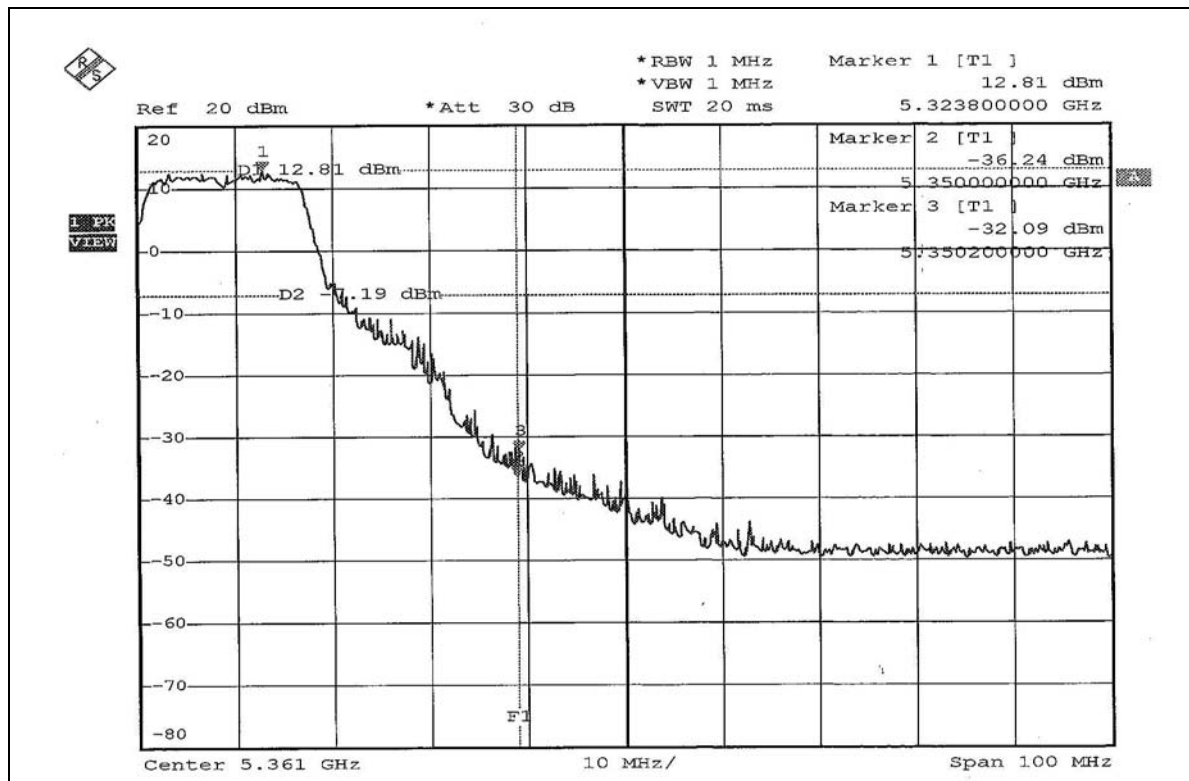
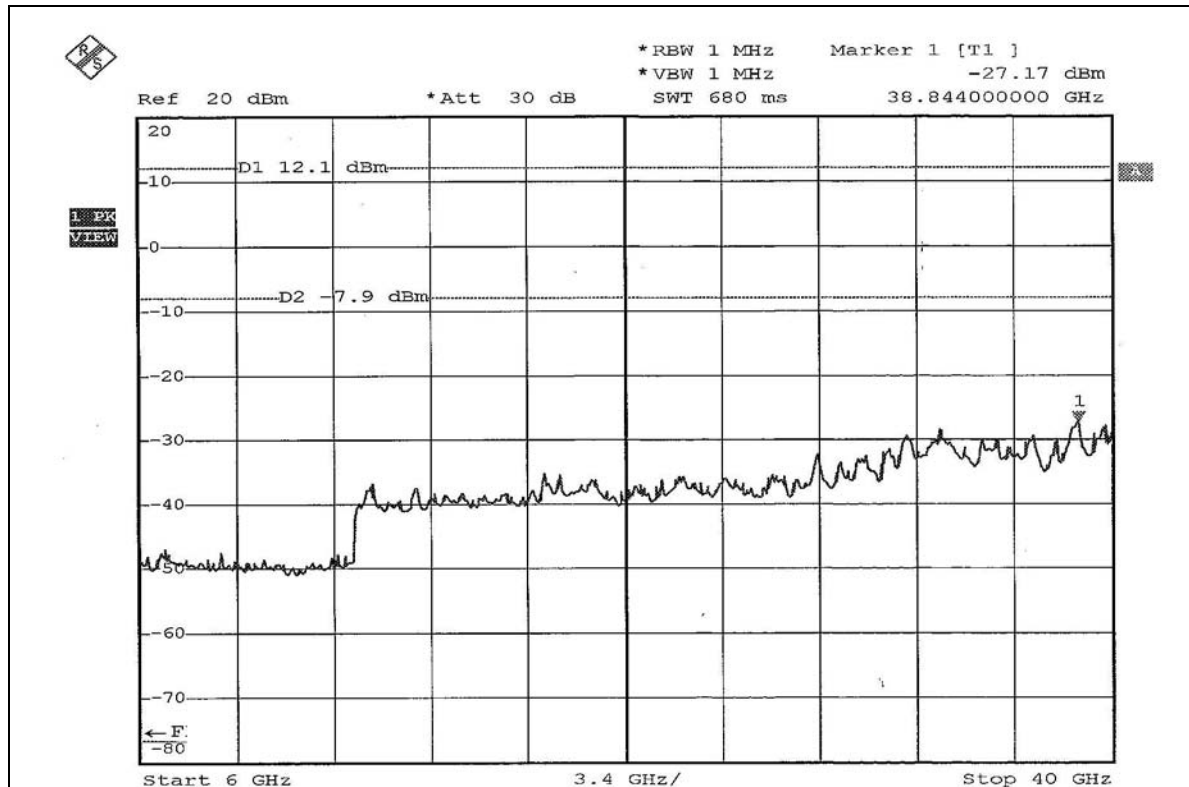

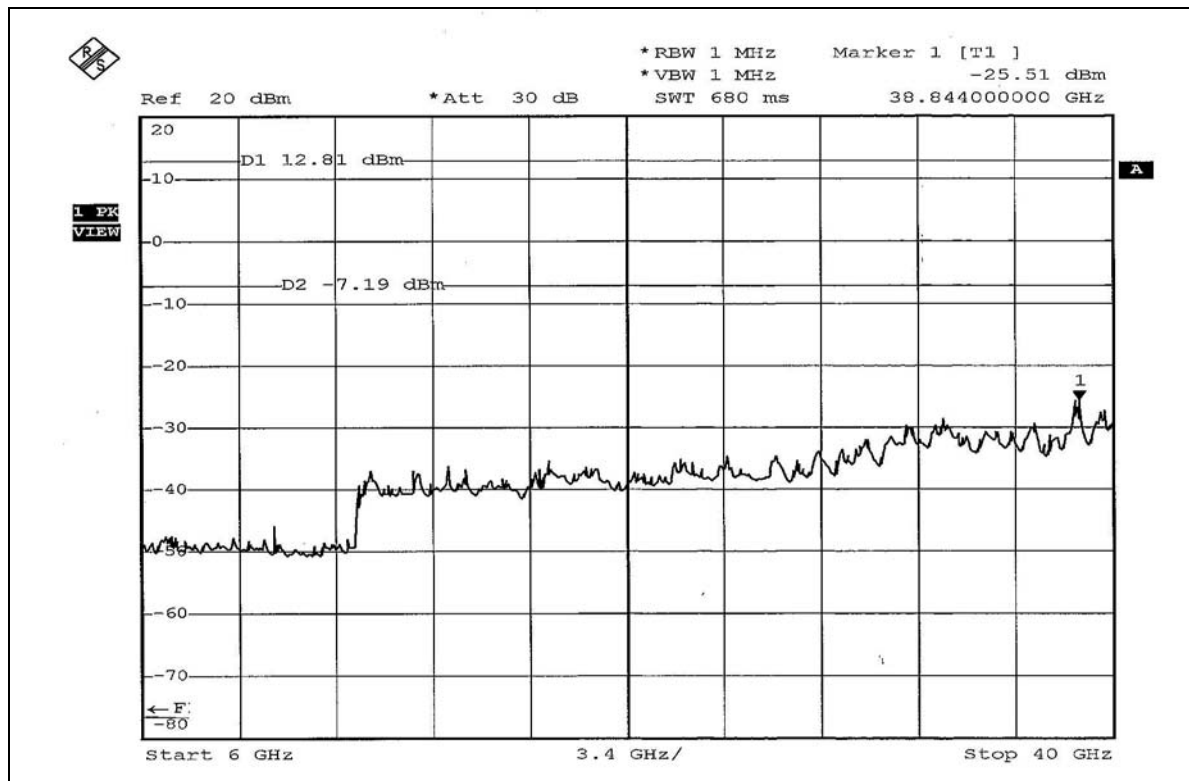
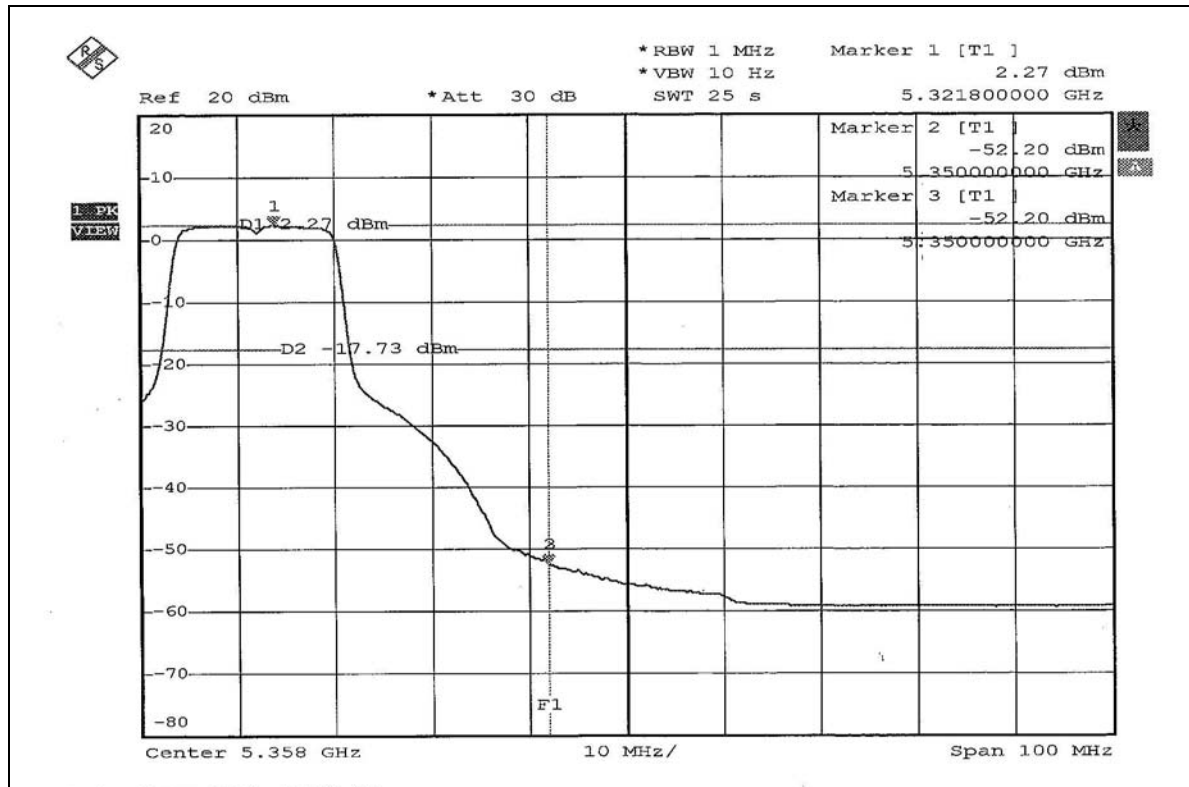



802.11a Turbo OFDM modulation

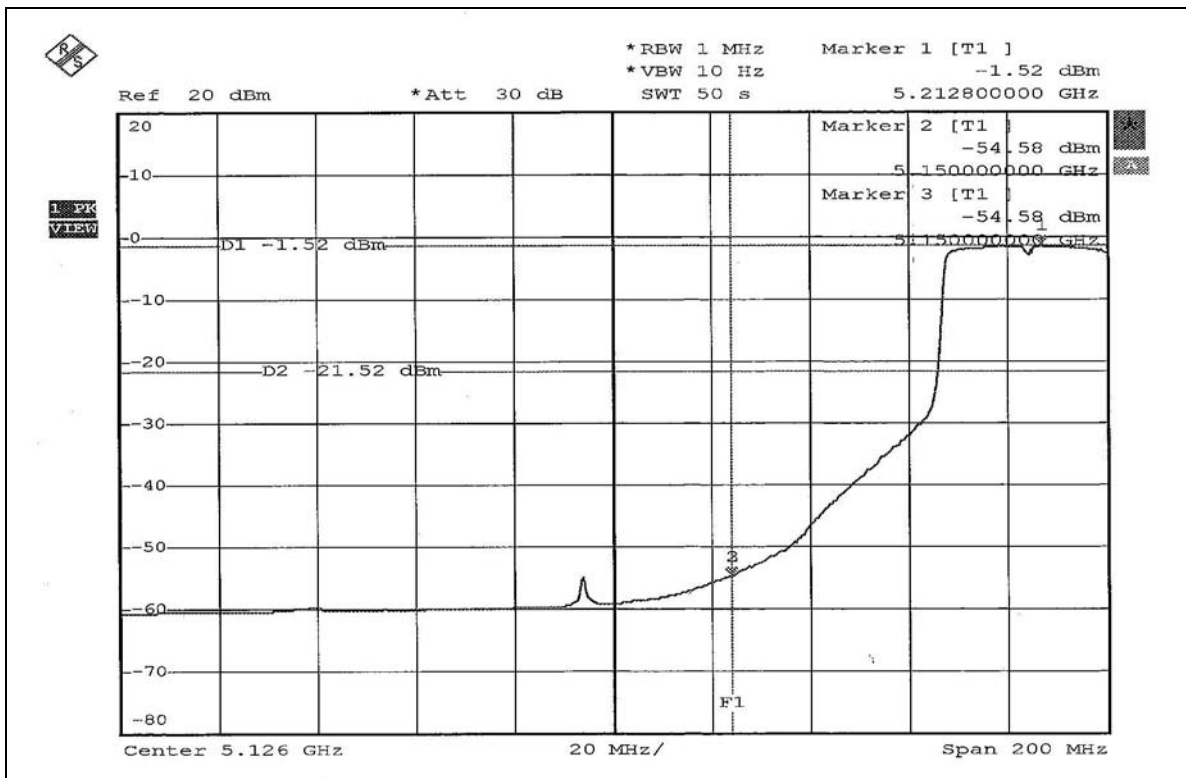
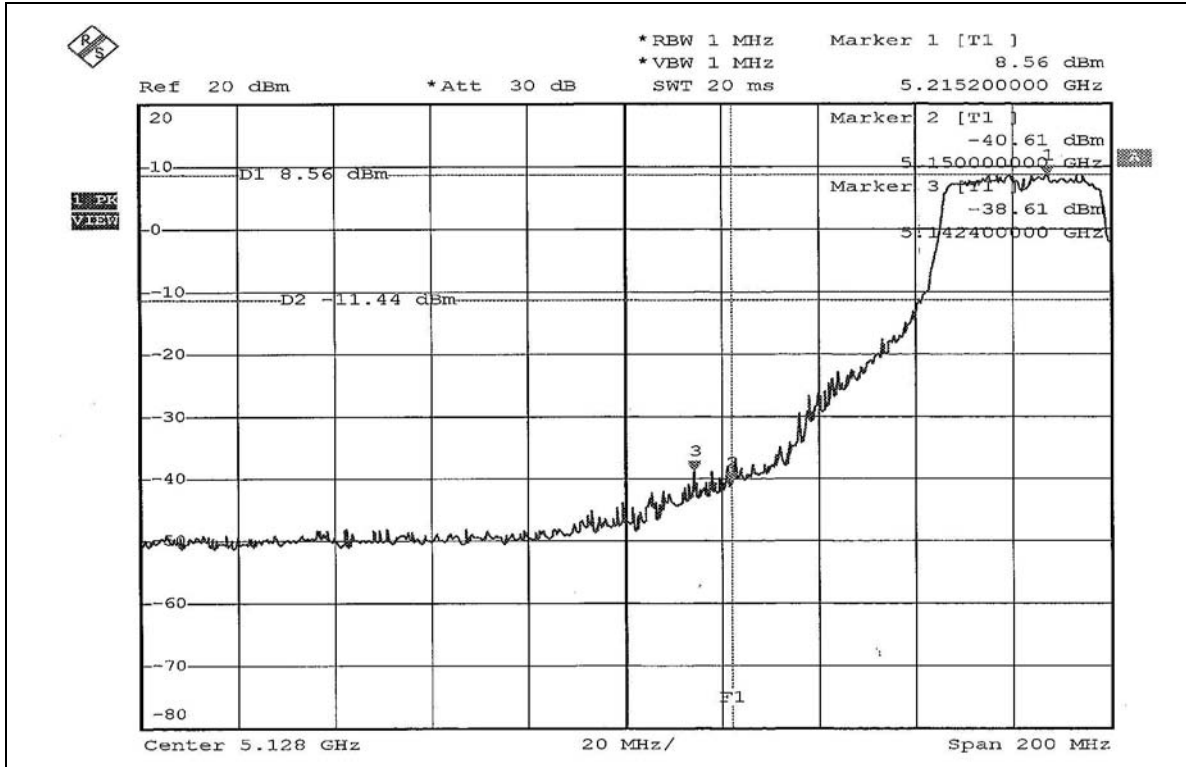

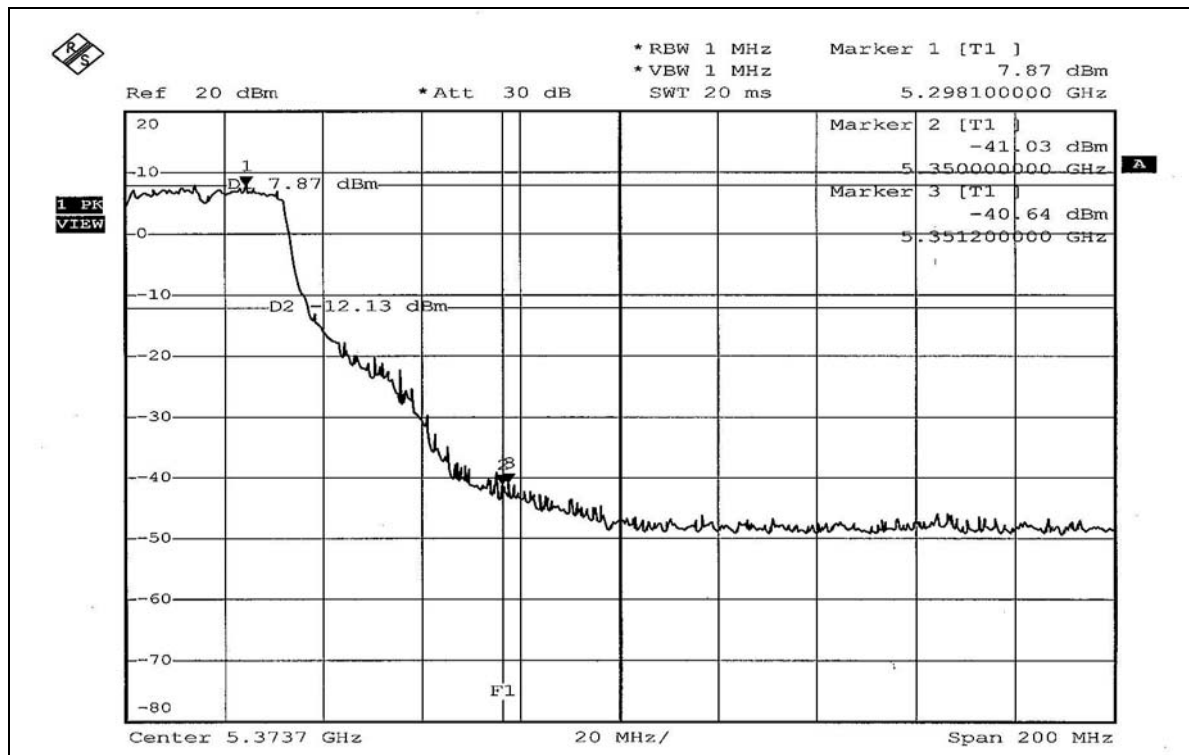
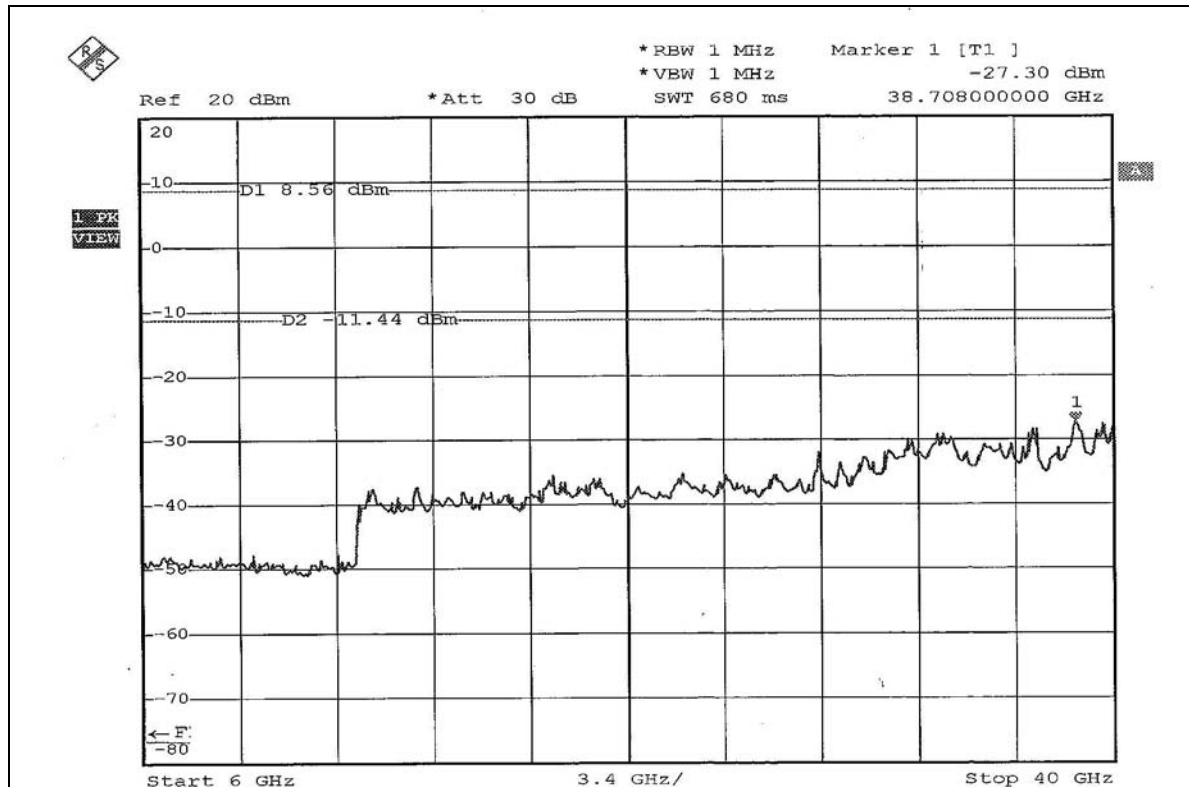

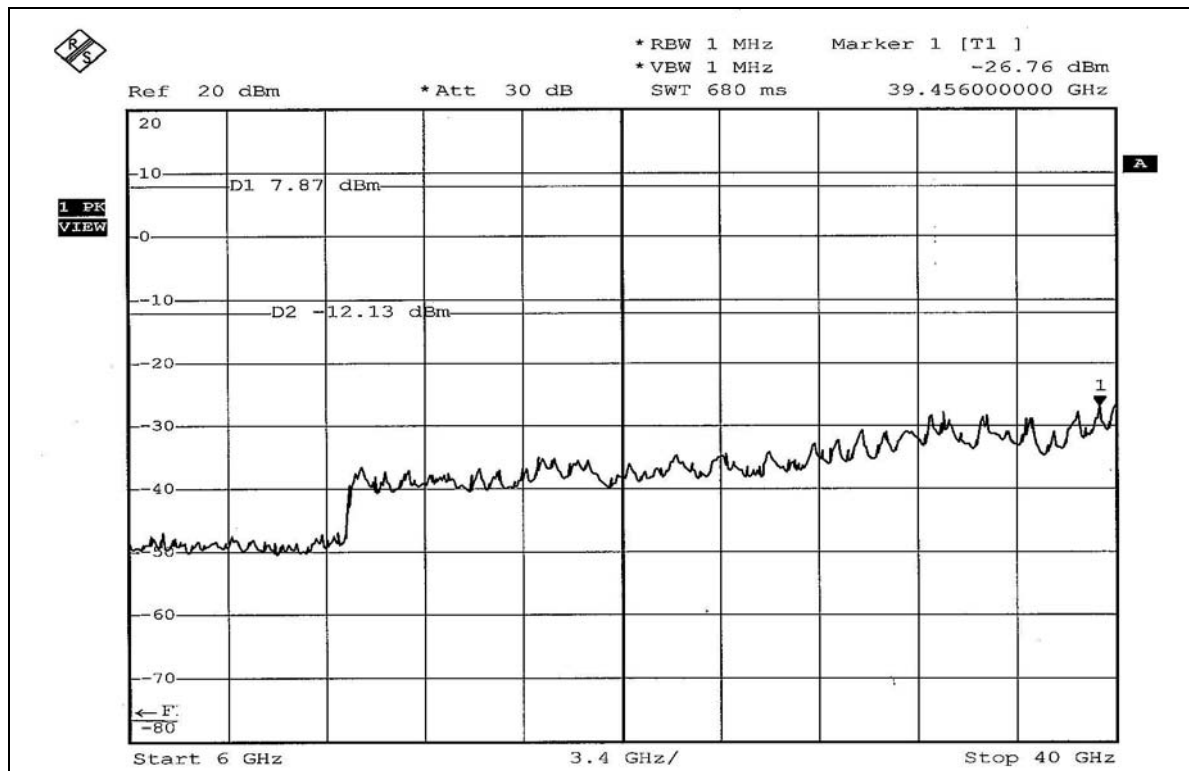
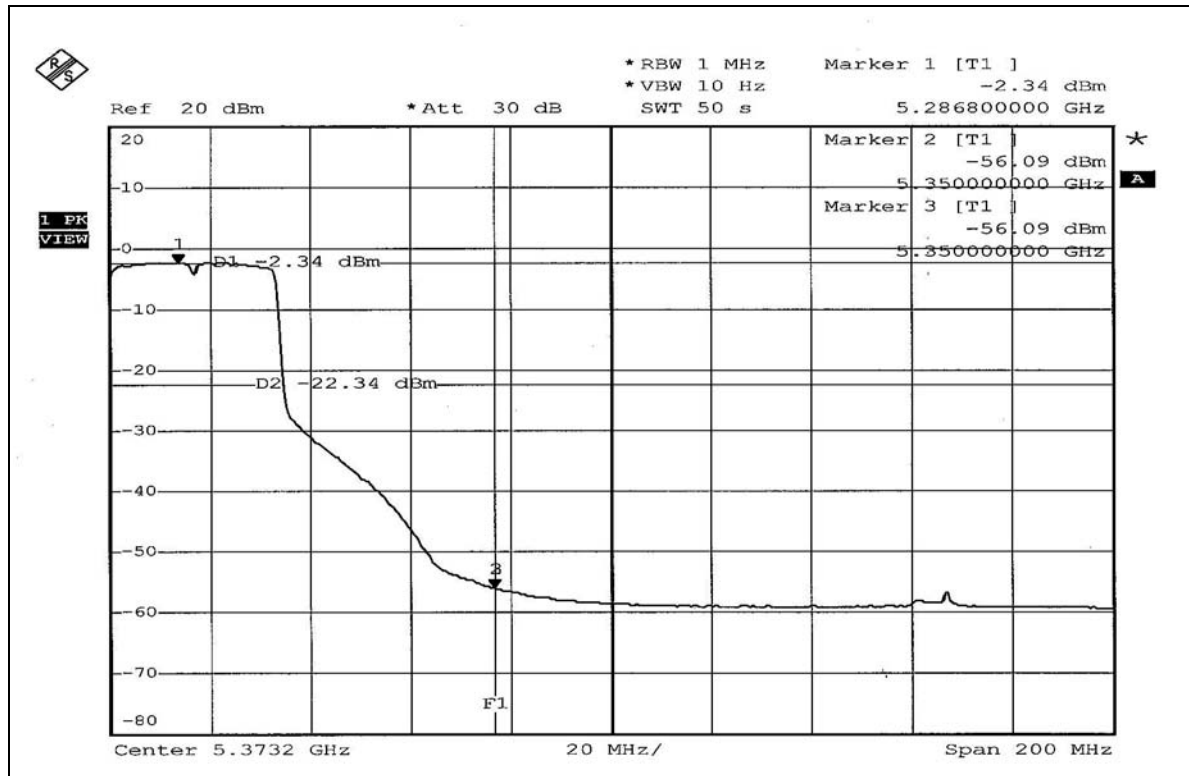



4.8 ANTENNA REQUIREMENT

4.8.1 STANDARD APPLICABLE

For intentional device, according to FCC 47 CFR Section 15.203, an intentional radiator shall be designed to ensure that no antenna other than that furnished by the responsible party shall be used with the device.

And according to FCC 47 CFR Section 15.407(a), if transmitting antennas of directional gain greater than 6dBi are used, the power shall be reduced by the amount in dB that the directional gain of the antenna exceeds 6dBi.

4.8.2 ANTENNA CONNECTED CONSTRUCTION

The antenna used in this product is Printed antenna without connector. The maximum Gain of the antenna is 0dBi.

5. PHOTOGRAPHS OF THE TEST CONFIGURATION CONDUCTED EMISSION TEST



RADIATED EMISSION TEST

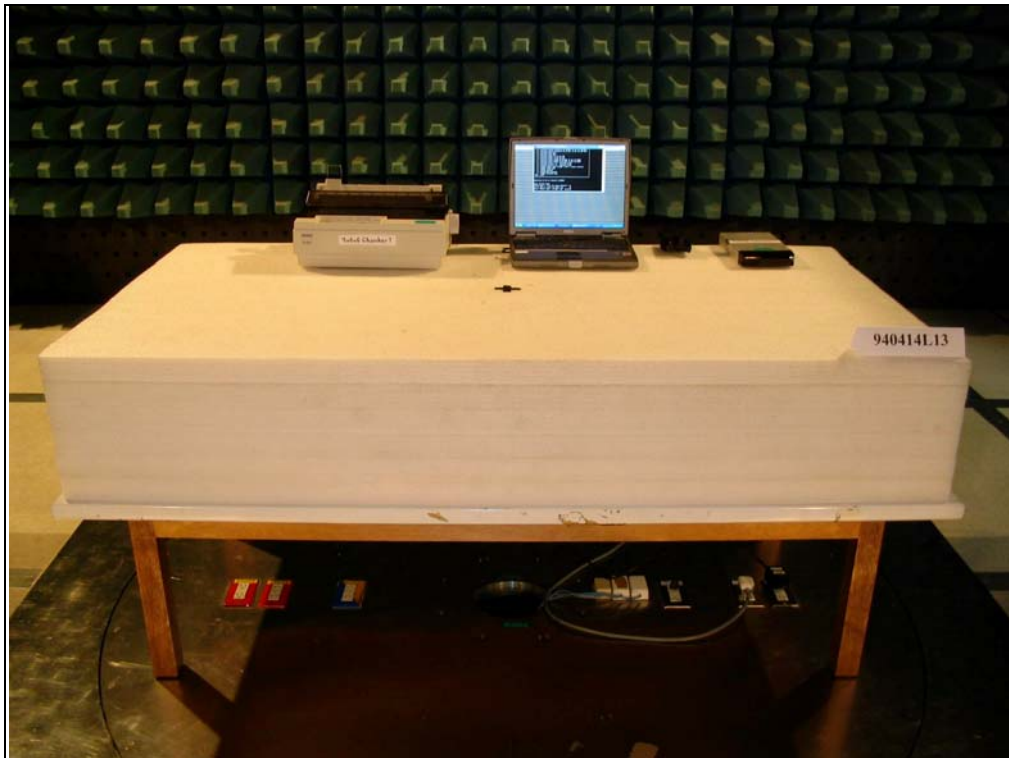



6. INFORMATION ON THE TESTING LABORATORIES

We, ADT Corp., were founded in 1988 to provide our best service in EMC, Radio, Telecom and Safety consultation. Our laboratories are accredited and approved by the following approval agencies according to ISO/IEC 17025:

USA	FCC, NVLAP, UL, A2LA
Germany	TUV Rheinland
Japan	VCCI
Norway	NEMKO
Canada	INDUSTRY CANADA , CSA
R.O.C.	CNLA, BSMI, DGT
Netherlands	Telefication
Singapore	PSB , GOST-ASIA(MOU)
Russia	CERTIS(MOU)

Copies of accreditation certificates of our laboratories obtained from approval agencies can be downloaded from our web site:

www.adt.com.tw/index.5/phtml. If you have any comments, please feel free to contact us at the following:

Linko EMC/RF Lab:

Tel: 886-2-26052180

Fax: 886-2-26052943

Hsin Chu EMC/RF Lab:

Tel: 886-3-5935343

Fax: 886-3-5935342

Hwa Ya EMC/RF/Safety Telecom Lab:

Tel: 886-3-3183232

Fax: 886-3-3185050

Linko RF Lab.

Tel: 886-3-3270910

Fax: 886-3-3270892

Web Site: www.adt.com.tw

The address and road map of all our labs can be found in our web site also