

1 BLOCK DIAGRAM(S) OF EQUIPMENT

1.1 Clock list of ARVA9000 product

Crystal: 4 MHz used for processor
 3.656 MHz which gives 457 KHz after division

1.2 Block diagram

Block diagram in emission mode:

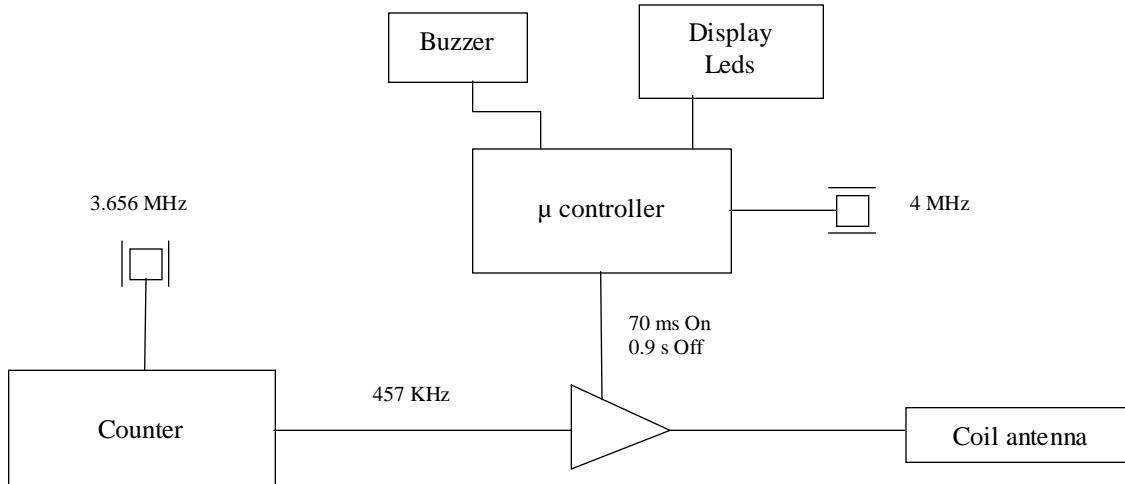

Block diagram in reception mode:

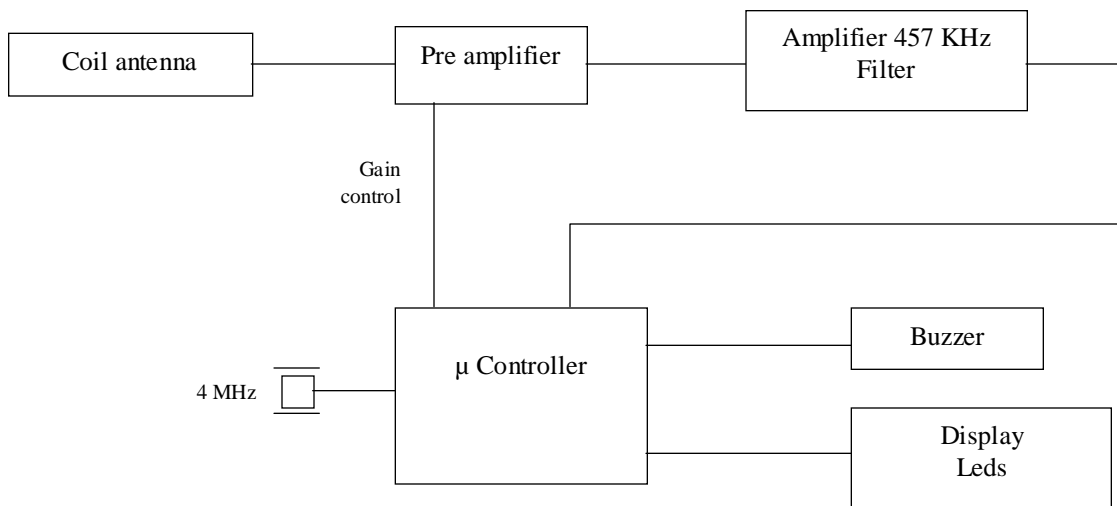

1.3 Modulation

The 457 KHz signal is pulsed: width of the pulse is about 70 ms ON for 1 s OFF.

The following plots show the signal modulation :

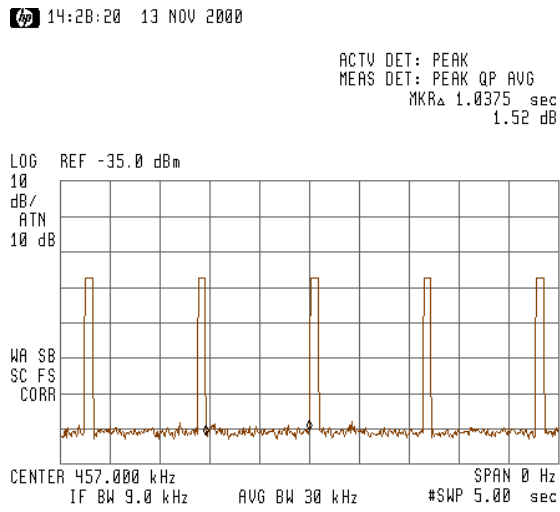

Pulsed signal versus time, for a zero span

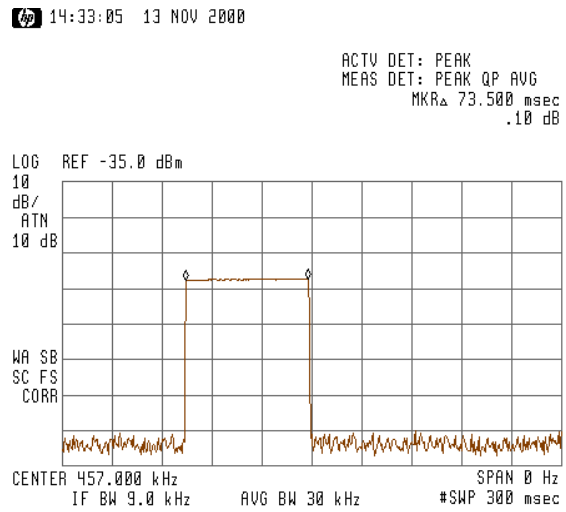

Detail of a previous pulse