

# Gcube Series Receipt Printer

User Guide

All specifications are subject to change without notice.



**SAM4S**



## Warning - U.S.

This equipment has been tested and founded to comply with the limits for a Class A digital device pursuant to Part 15 of the FCC Rules. These limits are designed to provide reasonable protection against harmful interference when the equipment is operated in a commercial environment. This equipment generates uses, and can radiate radio frequency energy and, if not installed and used in accordance with the instruction manual, may cause harmful interference to radio communications.

In case, Operation of this equipment in a residential area is likely to cause harmful interference to radio communications. the user will be required to correct the interference at his own expense.

## Notice - Canada

This Apparatus complies with class "A" limits for radio interference as specified in the Canadian department of communications radio interference regulations.

Get appareil est conforme aux normes class "A" d'interference radio tel que specifier par ministre canadien des communications dans les reglements d'interference radio.

## Warning

This is a Class A product. In a domestic environment this product may cause radio interference in which case the user may be required to take adequate measures.

## FCC compliance Information(for WLAN and BLUETOOTH)

This device complies with part 15 of FCC Rules. Operation is subject to the following two conditions: (1) This device may not cause harmful interference, and (2) This device must accept any interference received, including interference that may cause undesired operation.

## Information to the user

**NOTES** : *This equipment has been tested and found to comply with the limits for a Class B digital device, pursuant to part 15 of the FCC Rules.*

These limits are designed to provide reasonable protection against harmful interference in a residential installation.

This equipment generates, uses and can radiate radio frequency energy and, if not installed and used in accordance with the instructions, may cause harmful interference to radio communications. However, there is no guarantee that interference will not occur in a particular installation.

If this equipment does cause harmful interference to radio or television reception,

which can be determined by turning the equipment off and on, the user is encouraged to try to correct the interference by one or more of the following measures:

- Reorient or relocate the receiving antenna.
- Increase the separation between the equipment and receiver.
- Connect the equipment into an outlet on a circuit different from that to which the receiver is connected.
- Consult the dealer or an experienced radio/TV technician for help.

## [IMPORTANT NOTE]

FCC RF Radiation Exposure Statement:

This equipment complies with FCC RF radiation exposure limits set forth for an uncontrolled environment. This equipment should be installed and operated with a minimum distance of 20centimeters between the radiator and your body.

This transmitter must not be co-located or operating in conjunction with any other antenna or transmitter.

## Caution

Some semiconductor devices are easily damaged by static electricity. You should turn the printer "OFF", before you connect or remove the cables on the rear side, in order to guard the printer against the static electricity. If the printer is damaged by the static electricity, you should turn the printer "OFF" and contact your dealer for assistance.

## INTRODUCTION

The Gcube Series Roll Printer is designed for use with electronic instruments such as system ECR, POS, banking equipment, computer peripheral equipment, etc.

The main features of the printer are as follows:

1. High speed printing  
GCUBE-100 : 250mm/s, 59 lines per second(12X24 Font)  
GCUBE-102 : 250mm/s, 66 lines per second(12X24 Font)
2. Low noise thermal printing.
3. Support a variety of interfaces :  
USB+ETHERNET+BT
4. Jam free (Implementation of automatic return of Cutter Jam)

5. Characters can be scaled up to 64 times compared to its original size.
6. The data buffer allows the unit to receive print data even during printing.
7. Bar code printing is possible by using a bar code command.
8. Peripheral units drive circuit enables control of external devices such as cash drawer.
9. 2-dimensional bar code(QR code, PDF-417) and Two color printing.

Please be sure to read the instruction in this manual carefully before using Gcube Series.

**NOTES :** *The Power outlet shall be near the equipment and it should be easily accessible.*

## LEGISLATION AND WEEE SYMBOL

2002/96/CE Waste Electrical and Electronic Equipment Directive on the treatment, collection, recycling and disposal of electric and electronic devices and their components.



The crossed dustbin symbol on the device means that it should not be disposed of with other household wastes at the end of its working life. Instead, the device should be taken to the waste collection centres for activation of the treatment, collection, recycling and disposal procedure.

To prevent possible harm to the environment or human health from uncontrolled waste disposal, please separate this from other types of wastes and recycle it responsibly to promote the sustainable reuse of material resources.

Household users should contact either the retailer where they purchased this product, or their local government office, for details of where and how they can take item for environmentally safe recycling.

Business users should contact their supplier and check the terms and conditions of the purchase contract.

This product should not be mixed with other commercial wastes for disposal.

# Contents

<b>Chapter 1. Setting Up the Printer</b> .....	<b>7</b>
1.1. Unpacking .....	7
1.2. Connecting the Cables .....	8
1.3. Connecting the host device .....	9
1.4. Connecting the Drawer .....	9
1.5. Connecting the Power Supply .....	10
1.6. Installing options & Replacing the Paper Roll .....	11
1.6.1. Wall Mount Installation .....	11
1.6.2. Paper Roll Installation .....	12
1.7. Adjustments and Settings .....	13
1.7.1. How to install App .....	13
1.7.2. Change device setting .....	14
1.7.3. Bluetooth setting .....	15
1.8. Using the Printer .....	16
1.8.1. Control Panel .....	16
1.8.2. Button .....	16
1.8.3. Panel lights : FND .....	16
<b>CHAPTER 2. APPENDIX</b> .....	<b>18</b>
2.1. Adjusting the Paper Near-End Sensor Location .....	18
2.2. Printer Head Cleaning .....	19
2.3. Error Status and Error Resolution .....	20
2.4. Specification .....	22
2.4.1. General Printer specification .....	22
2.4.2. Paper specification .....	22

## 1.1. Unpacking

Your printer box should include these items. If any items are damaged or missing, please contact your dealer for assistance.

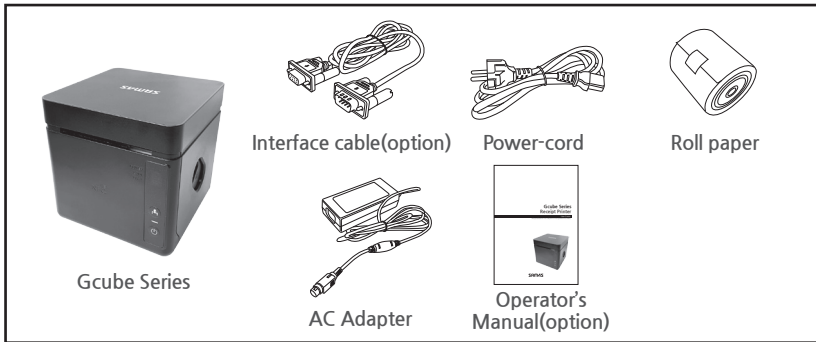

## 1.2. Connecting the Cables

You can connect up to three cables to the printer. They are all connected to the connector panel on the back of the printer, which is shown as below:

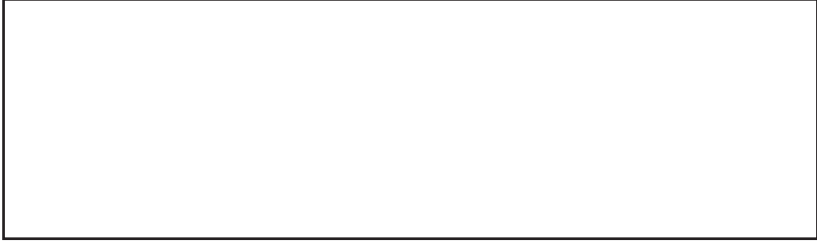

< GCUBE-100B >



## 1.3. Connecting the host device

You need the appropriate interface cable.

1. Plug the cable connector securely into the printer's interface connector.
2. Attach the other end of the cable to the host device.

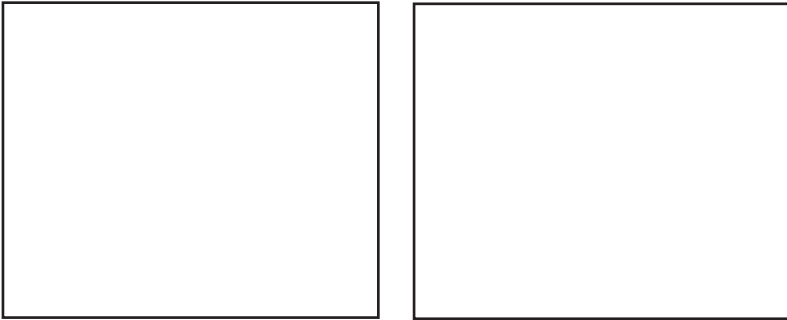

## 1.4. Connecting the Drawer

**WARNING** : Use a drawer that matches the printer specification.

*Using an improper drawer may damage the drawer as well as the printer.*

**CAUTION** : Do not connect a telephone line to the drawer kick-out connector; otherwise the printer and the telephone line may be damaged.

*Plug the drawer cable into the drawer kick out connector on the back of the printer next to the power supply connector. Drawer 2 and Kitchen Bell can not be used at the same time. (Board Buzzer and Internal KB are the same)*

To use the drawer, you can connect the cable to the connector.



## 1.5. Connecting the Power Supply

**WARNING** : Make sure that you use the power supply provided with the printer or equivalent.

**CAUTION** : When connecting or disconnecting the power supply from the printer, make sure that the power supply is not plugged into an electrical outlet. Otherwise you may damage the power supply or the printer.

If the power supply's rated voltage and your outlet's voltage do not match, contact your dealer for assistance. Do not plug in the power cord. Otherwise, you may damage the power supply or the printer.

1. Make sure the printer is turned off.
2. Plug the DC cord connector into the power jack on the printer. If it is necessary to connect the interface and the drawer, plug that connector into the port on the printer. And clean up the cables.

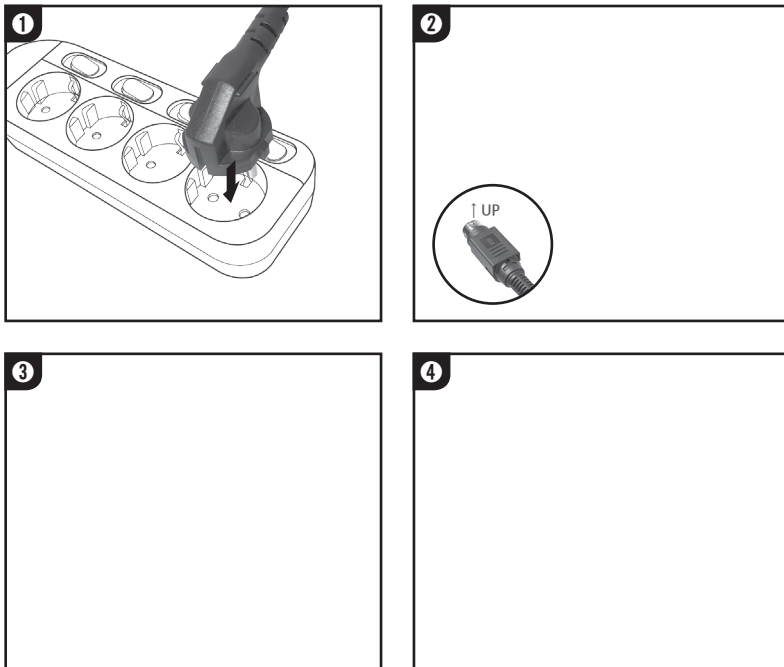

**NOTES** : To remove the DC cable connector, make sure the power supply's power cord is unplugged and then grasp the connector at the arrow and pull it straight out.

## 1.6. Installing options & Replacing the Paper Roll

### 1.6.1. Wall Mount Installation

1. Using the bracket, mark it on the wall where you want to install the printer.
2. Make 3 holes in the marked places.
3. Install the wall mount bracket with screws as in picture 3.
4. Align the wall bracket and the printer and slide down the printer to fit in.

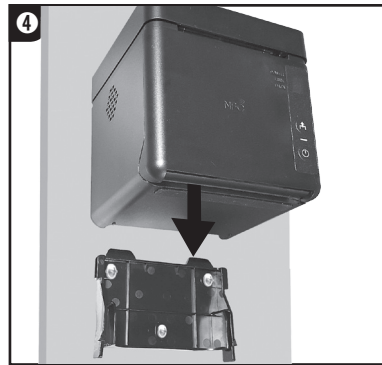
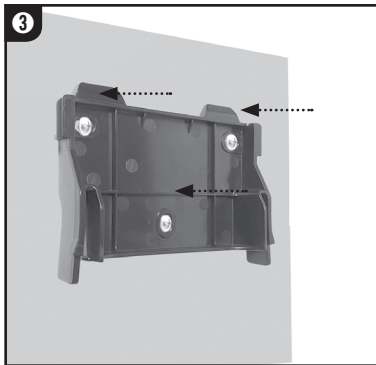
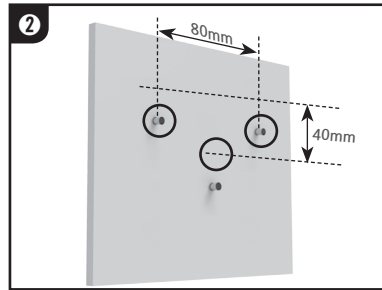
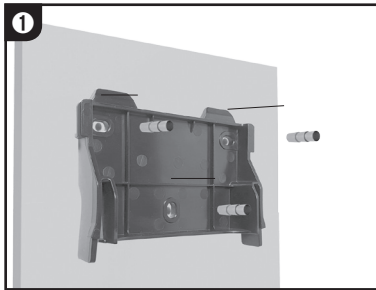

## 1.6. Installing options & Replacing the Paper Roll

### 1.6.2. Paper Roll Installation

**NOTES :** Be sure to use paper rolls that meet the specifications.

Do not use paper rolls that have the paper end glued to the core.

1. Open the paper roll cover by pressing the cover-open button.

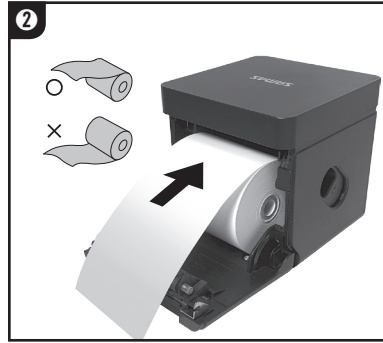
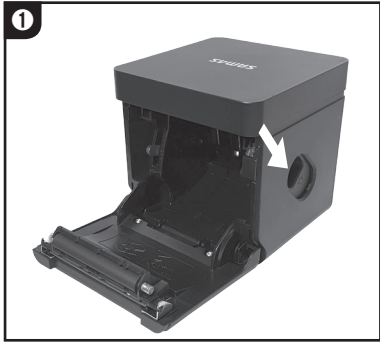

**NOTES :** To avoid printer damage, do not open the printer cover during printing.

2. Remove the used paper roll core if there is one.
3. Insert the paper roll as shown.
4. Pull out a small amount of paper as shown in picture no.3. and close the printer cover. Tear off the paper as shown.

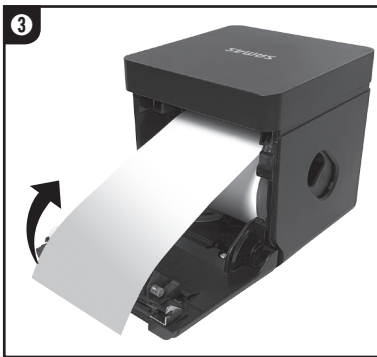

## 1.7. Adjustments and Settings

Printer settings can be changed using NFC APP

### 1.7.1 How to install APP

1. Configure NFC Function from User's Smart Phone into Read/Write, P2P Mode. (not workable in a Card Mode)
2. Tag your cellphone horizontally on NFC logo with the cellphone screen unlocked.

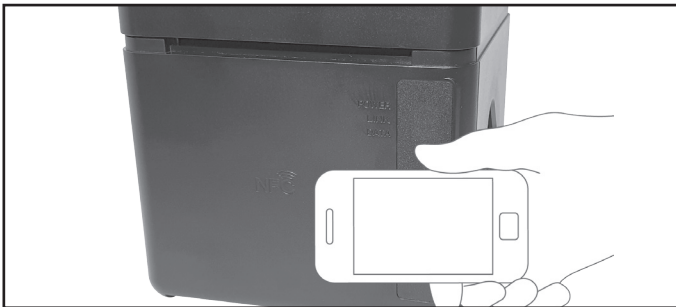

3. If NFC is well recognized, Gcube APP Installation Screen from Google Play Store runs automatically.
4. Press the Installation Button on Installation Screen, then it will be installed in User's smart phone.

» No.2 Manual Installation Mode

1. Run Google Play Store from User's Smart Phone.
2. In Search Bar, insert "Gcube NFC" and search it.
3. After a search, choose "Gcube NFC" from the list.
4. Press Installation Button for Gcube APP to be installed.

# 1.7. Adjustments and Settings

## 1.7.2 Change device setting

1. In Device Settings Menu, Run a Config the setting values.
2. Change setting values you wish to change on a Setting screen. After completion of setting, touch the upper screen.
3. If the message “Tag on Gcube” appears in the middle of screen, then tag a smart phone on Printer.
4. When the message “Writing completed” appears while tagging the smart phone on the Printer, then tag the smart phone off Printer.
5. When the setting is well done, printer will print Self-Test Page after reset.

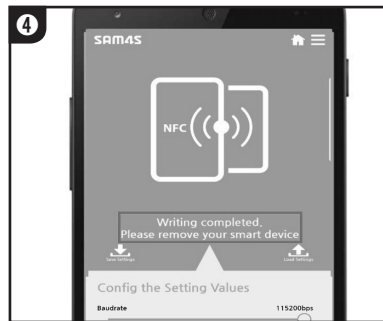
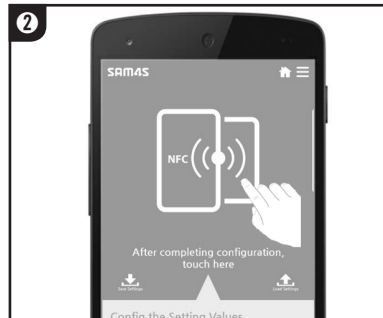

## 1.7. Adjustments and Settings

### 1.7.3 Bluetooth setting

1. Run a Smart BT Linke.
2. If the message “Tag on Gcube” appears in the middle of screen, then tag a smart phone on Printer.
3. Change the Device Address, Device Name, Pin Code and click the Create button.
4. When the message “Tag on Gcube” appears in the middle of screen, then tag a smart phone on Printer.
5. When the setting is well done, printer will print Self-Test Page after reset.

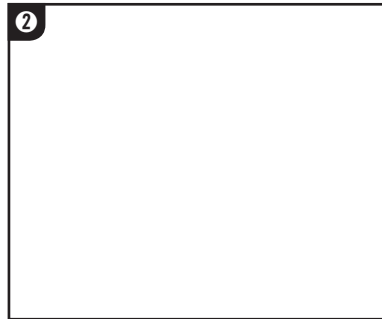
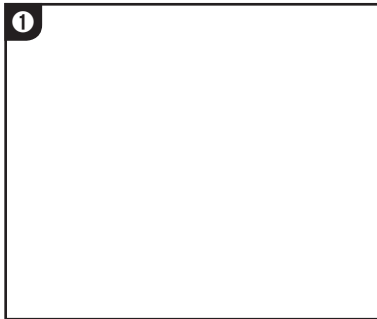

## 1.8. Using the Printer

### 1.8.1. Control Panel

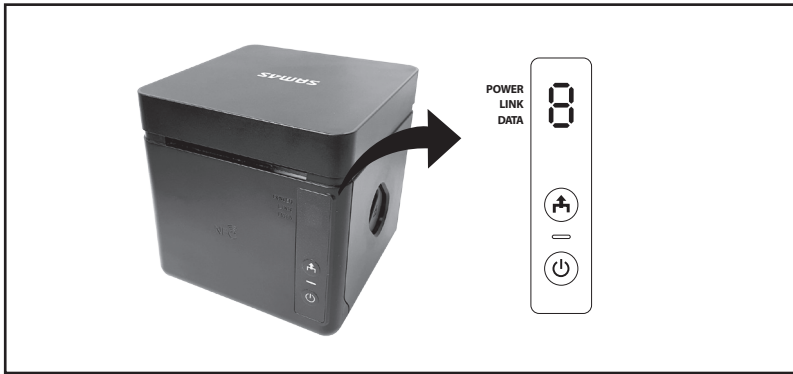

### 1.8.2. Button

- **POWER Button** (⏻)

Press the POWER button to turn on the printer. "-" is displayed on the FND.

- **FEED Button** (➡)

Press the FEED button once to advance paper one line. You can also hold down the FEED button to feed paper continuously. The button can be disabled by the ESC c 5 command.

### 1.8.3. Panel lights : FND

- **ERROR FND** (⊠)

This indicates when there is " Power on" error or no receipt paper left/ almost used up. For detailed error type, kindly refer 2-3 Error Status and Error Resolution on page <20-21>.





## 2.1. Adjusting the Paper Near-End Sensor Location

The sensor has five sensitivity settings.

1. Push the open button and open the printer cover.
2. If you find there is too much paper remaining when the sensor is triggered, set the near end sensor to position #4 or #5.
3. Decrease the setting if the paper runs out before the sensor is triggered.

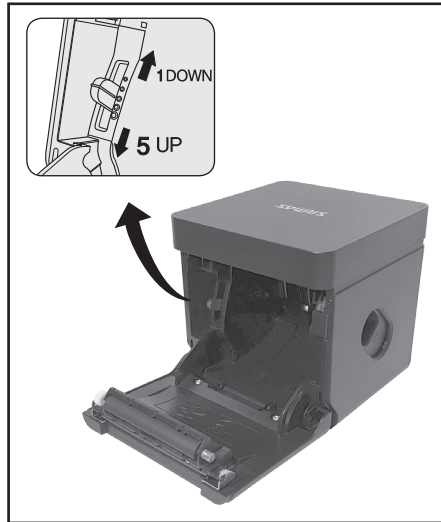

The accuracy of the Near-End sensor depends on the adjustment scale setting and the winding core diameter of the roll paper. The Near-End sensor is set at adjustment #3. This is the appropriate scale for the recommended paper thickness.

The factory default setting is at position #3.

**NOTES :** Paper core diameter varies by paper manufacturer.

## 2.2. Printer Head Cleaning

Paper dust on the heating elements may lower the printing quality. In this case, clean the printer head as follows:

**NOTES :** Before cleaning the inside of printer or the head, make sure the power is off.

1. Power off the printer.
2. Open the printer cover.
3. Clean the thermal elements of the printer head using a cotton swab moistened with alcohol solvent (ethanol, methanol, IPA)
4. Insert a paper roll and close the printer cover.

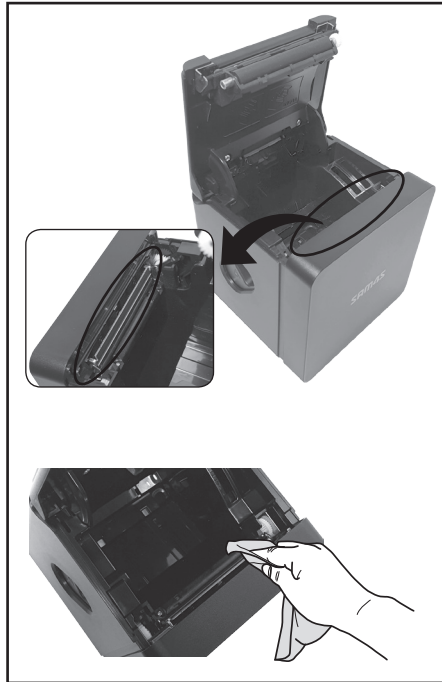

## 2.3. Error Status and Error Resolution

When the printer error occurs, the alphabet corresponding to the error condition is shown on FND

Error Status Indicator includes:

- Cutter Jam 

When ERROR FND indicates "J", the printer is on Cutter Jam error status.

- » **Solution**

While the printer is turned on (the Power LED is on,) press the cover button and open the cover. Then, the cutter will automatically reset.



- Cutter Not Home 

When ERROR FND indicates "J", it means the cutter is not in Home position while the printer is on.

- » **Solution**

Same solution as Cutter Jam error.

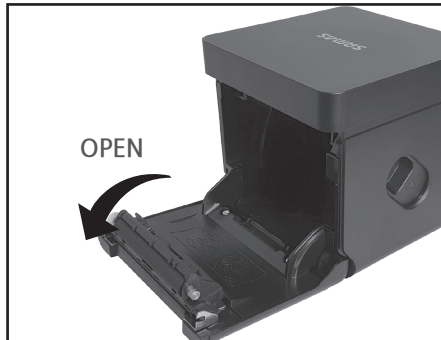

## 2.3. Error Status and Error Resolution

When the printer error occurs, the alphabet corresponding to the error condition is shown on FND

Error Status Indicator includes:

- **Paper Out Error** (P)

The buzzer beeps “ Beep---,Beep---” and When the printer cover open by pressing the cover open button, the buzzer will stop. After this, you may change the paper roll and continue using the printer.

- **Cover Open** (C)

This error occurs when the printer cover is open. Closing the cover will clear the error.

- **Replace paper** (R)

This error occurs when the paper needs to be replaced.

- **Overheat** (H)

This error occurs when the print head is overheated. Printing stops with an overtemperature error. When the printer head cools down, the error is cleared and printing continues.

## 2.4. Specification

### 2.4.1. General Printer specification

Printing method	Thermal Line Printing
Resolution	180DPI (GCUBE-100) 203DPI (GCUBE-102)
Printing width	72mm
Paper width	80mm
Characters per line(default)	Font A : 42(GCUBE-100), 48(GCUBE-102) Font B : 56(GCUBE-100), 64(GCUBE-102)
Printing speed	59 lines/sec(250mm/sec, GCUBE-100) 66 lines/sec(250mm/sec, GCUBE-102)
Receive buffer size	Max 64kbytes

**NOTES** : Printing speed may be slower, depending on the data transmission speed and the combination of control commands.

Supply voltage	Input voltage	100 ~ 240V AC
	Frequency	50 ~ 60 Hz
	Output voltage	+24V DC
Environmental conditions	Temperature	5 ~ 45°C(Operating) -10 ~ 50°C(Storage)
	Humidity	10 ~ 90% RH; except the paper roll.
Lifespan	Printer Mechanism(MCBF)	70,000,000 lines
	TPH	1×10 <sup>8</sup> Pulse(150 Km)
	Auto Cutter	1,500,000 Cut

### 2.4.2. Paper specification

Item	Description	Remark
Paper Type	Hansol HPK-110	Black color
	Mitsubishi PB670	Red/Black color
	Mitsubishi PB770	Blue/Black color
Paper Form	Paper Roll	
Paper Width	80(+0,-1), 3.14n(+0,-0.039")	
Paper Roll Size	Max 83mm	
Spool Outside Dia	18mm(0.71")	

※ The Following paper can be used instead of the specified paper above.

- TF50KS-E : Nippon Paper industries Co., Ltd.
- PD 160R : New Oji Paper Mfg, Co.,Ltd.
- F380 : Kansaki Specialty Papers,Inc.(USA)

※ Mitsubishi PB670 / PB770 are two color mode papers.



# Gcube Series Receipt Printer

OPERATOR'S Manual