

TABLE OF CONTENTS LIST

APPLICANT: TOPAZ3, LLC

FCC ID: 07KML3245

TEST REPORT:

PAGE 1.....COVER SHEET - GENERAL INFORMATION & TECHNICAL DESCR.
PAGE 2.....TECHNICAL DESCRIPTION CONT. & RF OUTPUT POWER
PAGE 3.....MODULATION CHARACTERISTICS & AUDIO FREQUENCY RES PLOTS
PAGE 4.....MODULATION LIMITING PLOT - 300 & 1000 Hz (2.5kHz)
PAGE 5.....MOD. LIMITING PLOT - 2500Hz (2.5kHz) & 300Hz (5.0kHz)
PAGE 6.....MODULATION LIMITING PLOT - 1000 Hz & 2500 Hz (5.0kHz)
PAGE 7.....POST LIMITER PLOT
PAGE 8.....OCCUPIED BANDWIDTH
PAGE 9.....OCCUPIED BANDWIDTH PLOT - 20 khz
PAGE 10.....OCCUPIED BANDWIDTH PLOT - 11.25 kHz
PAGE 11.....SPURIOUS EMISSIONS AT ANTENNA TERMINALS
PAGE 12.....METHOD OF MEASURING SPURIOUS EMISSIONS AT ANTENNA
TERM.
PAGE 13-14..FIELD STRENGTH OF SPURIOUS EMISSIONS
PAGE 15.....METHOD OF MEASURING RADIATED SPURIOUS EMISSIONS
PAGE 16.....FREQUENCY STABILITY
PAGE 17-18..TRANSIENT FREQUENCY
PAGE 19.....TRANSIENT FREQUENCY PLOT - TURN ON HIGH
PAGE 20.....TRANSIENT FREQUENCY PLOT - TURN OFF HIGH
PAGE 21.....TRANSIENT FREQUENCY PLOT - TURN ON LOW
PAGE 22.....TRANSIENT FREQUENCY PLOT - TUNN OFF LOW
PAGE 23.....MPE CALCULATION
PAGE 24-26..LIST OF TEST EQUIPMENT

EXHIBITS CONTAINING:

EXHIBIT 1.....FCC ID LABEL SAMPLE
EXHIBIT 2.....SKETCH OF LOCATION
EXHIBIT 3.....BLOCK DIAGRAM
EXHIBIT 4.....SCHEMATICS
EXHIBIT 5.....USER'S MANUAL
EXHIBIT 6.....EXTERNAL PHOTOS
EXHIBIT 7.....INTERNAL PHOTOS
EXHIBIT 8.....PARTS LIST
EXHIBIT 9.....THEORY OF OPERATION
EXHIBIT 10.....TEST SETUP PHOTOGRAPHS
EXHIBIT 11.....STATEMENT PER 90.203(g)

APPLICANT: TOPAZ3, LLC

FCC ID: 07KML3245

REPORT #: T/Topaz3LLC_F3J\1266AUT2\1266AUT2TestReport.doc

TABLE OF CONTENTS LIST

GENERAL INFORMATION REQUIRED
FOR TYPE ACCEPTANCE

2.1033(c)(1)(2) TOPAZ3, LLC will manufacture the
FCCID: O7KML3245 VHF TRANSCEIVER in quantity, for use
under FCC RULES PART 90.

TOPAZ3, LLC
10828 NW AIRWORLD DRIVE
KANSAS CITY, KS 64153

2.1033 (c) TECHNICAL DESCRIPTION

2.1033(c)(3) Instruction book. A draft copy of the instruction
manual is included as EXHIBIT 5.

2.1033(c) (4) Type of Emission: 10K7F3E
90.209

$B_n = 2M + 2DK$
 $M = 3000$
 $D = 2350$
 $B_n = 2(3000) + 2(2350) = 10.7k$

Authorized Bandwidth 11.25 kHz

2.1033(c) (4) Type of Emission: 15K0F3E
90.209

$B_n = 2M + 2DK$
 $M = 3000$
 $D = 4500$
 $B_n = 2(3000) + 2(4500) = 15.0k$

Authorized Bandwidth 20.0 kHz

2.1033(c)(5) Frequency Range: 450-512MHz
90.209

2.1033(c)(6)(7) Power Output shall not exceed 45 Watts into a 50 ohm
90.205 resistive load.

2.1033(c)(8) DC Voltages and Current into Final Amplifier:
POWER INPUT:

FINAL AMPLIFIER ONLY
Vce = 13.6 Volts
IC LOW = 2.4 A
IC HIGH = 8.8 A

- 2.1033(c)(9) Tune-up procedure. The tune-up procedure is included in Exhibit 8.
- 2.1033(c)(10) Complete Circuit Diagrams: The circuit diagram is included as EXHIBIT 4. The block diagram is included as EXHIBIT 3.
- 2.1033(c)(11) A photograph or a drawing of the equipment identification label is included as Exhibit #1.
- 2.1033(c)(12) Photographs(8"X10") of the equipment of sufficient clarity to reveal equipment construction and layout, including meters, labels for controls, including any view under shields - See EXHIBIT 6-7.
- 2.1033(c)(13) Digital modulation is not allowed.
- 2.1033(c)(14) The data required by 2.1046 through 2.1057 is submitted below.

2.1046(a) RF power output.

90.205 RF power is measured by connecting a 50 ohm, Resistive wattmeter to the RF output connector. With a nominal battery voltage of 13.6 VDC, and the Transmitter properly adjusted, the RF output measures:

INPUT POWER: HIGH: (13.6V)(7A) = 95.20 Watts
 INPUT POWER: LOW: (13.6V)(2.5A) = 34 Watts
 OUTPUT POWER: HIGH: 40 Watts
 LOW: 2 Watts

METHOD OF MEASURING RF POWER OUTPUT

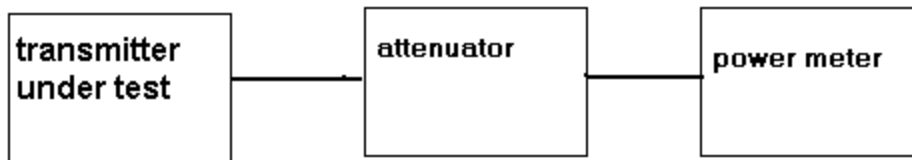

2.1047(a)(b) Modulation characteristics:

AUDIO FREQUENCY RESPONSE

The audio frequency response was measured in accordance with TIA/EIA Specification 603. The audio frequency response curve is shown below.

The audio signal was fed into a dummy microphone circuit and into the microphone connector. The input required to produce 30 percent modulation level was measured.

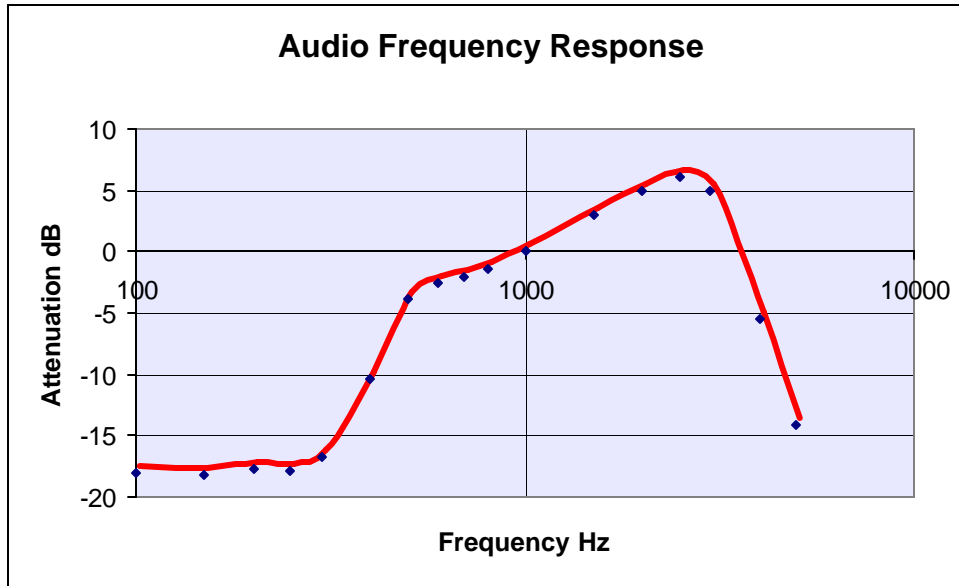

Audio Frequency Response with Narrow Band (2.5kHz)

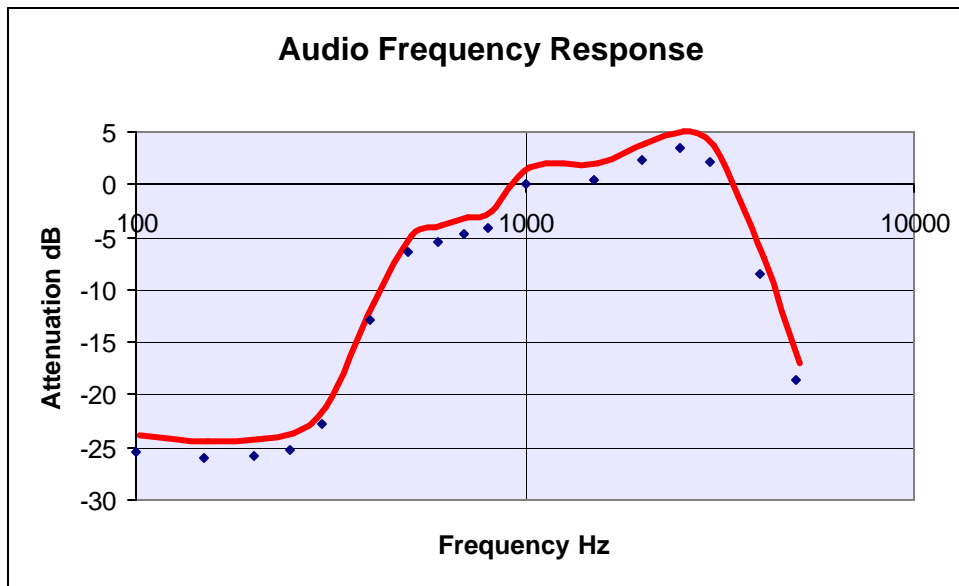

Audio Frequency Response with Wide Band (5.0kHz)

2.1047(b)

Audio input versus modulation

The audio input level needed for a particular percentage of modulation was measured in accordance with TIA/EIA Specification 603. The audio input curves versus modulation are shown below and on pages 5 and 6. Curves are provided for audio input frequencies of 300, 1000, and 2500 Hz.

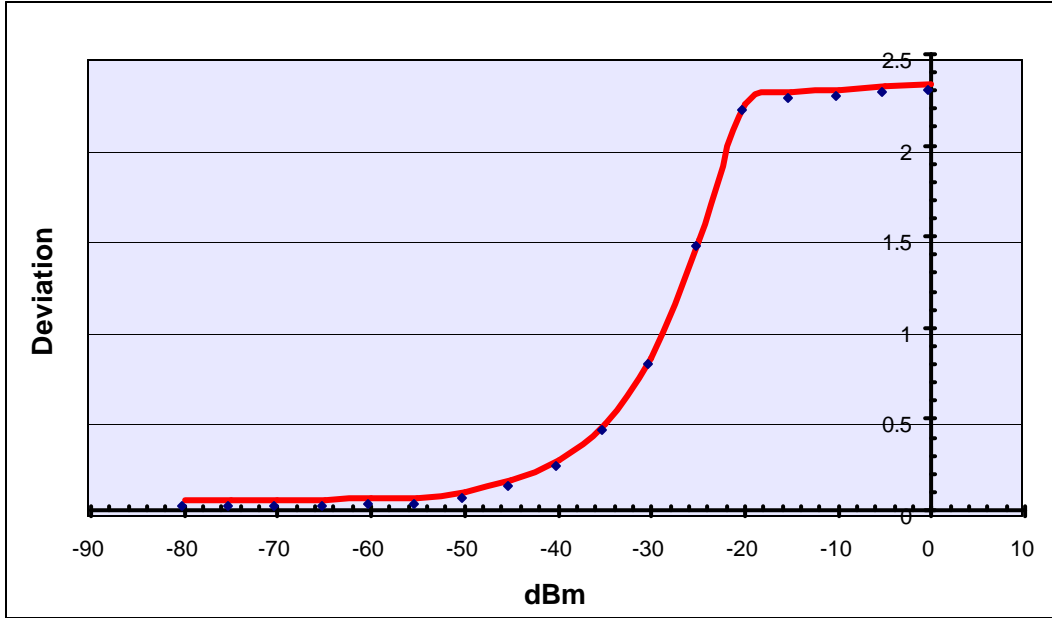

Modulation Limiting for 300Hz with 2.5kHz Dev.

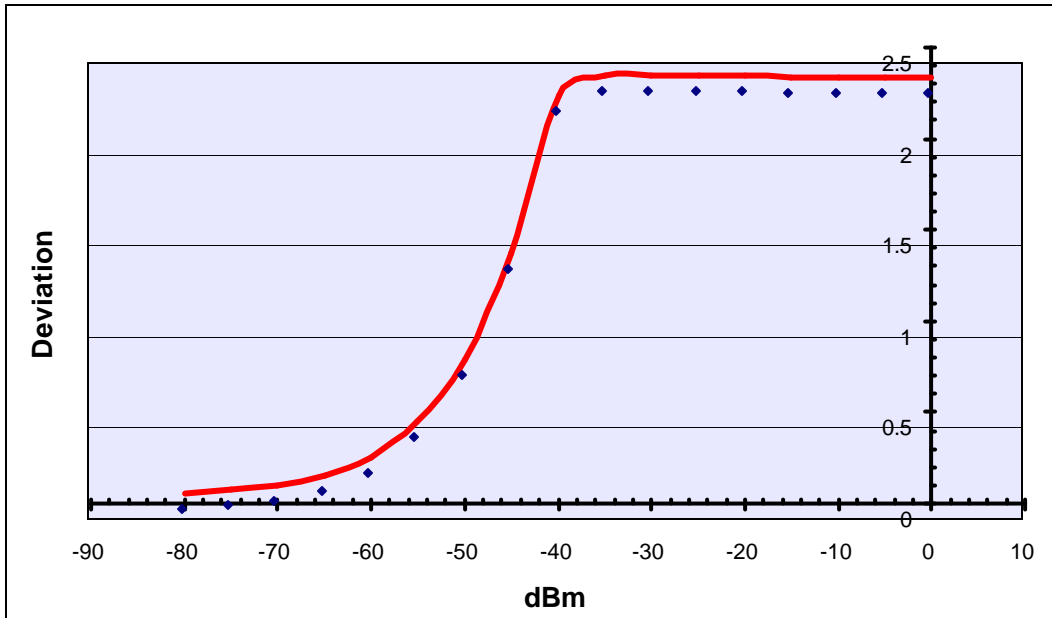

Modulation Limiting for 1000Hz with 2.5kHz Dev.

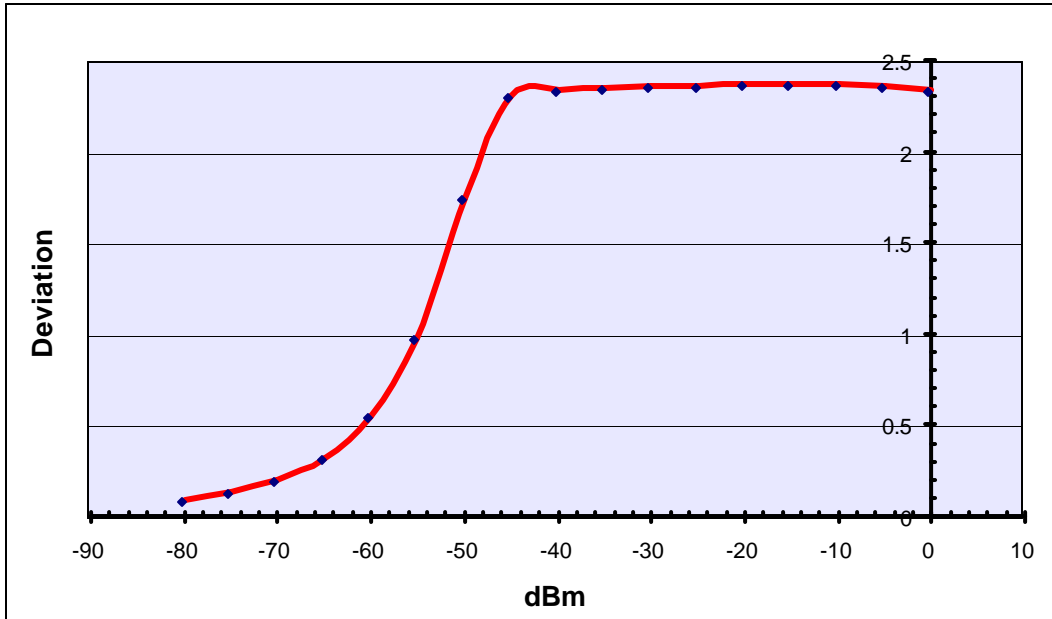

Modulation Limiting for 2500Hz with 2.5kHz Dev.

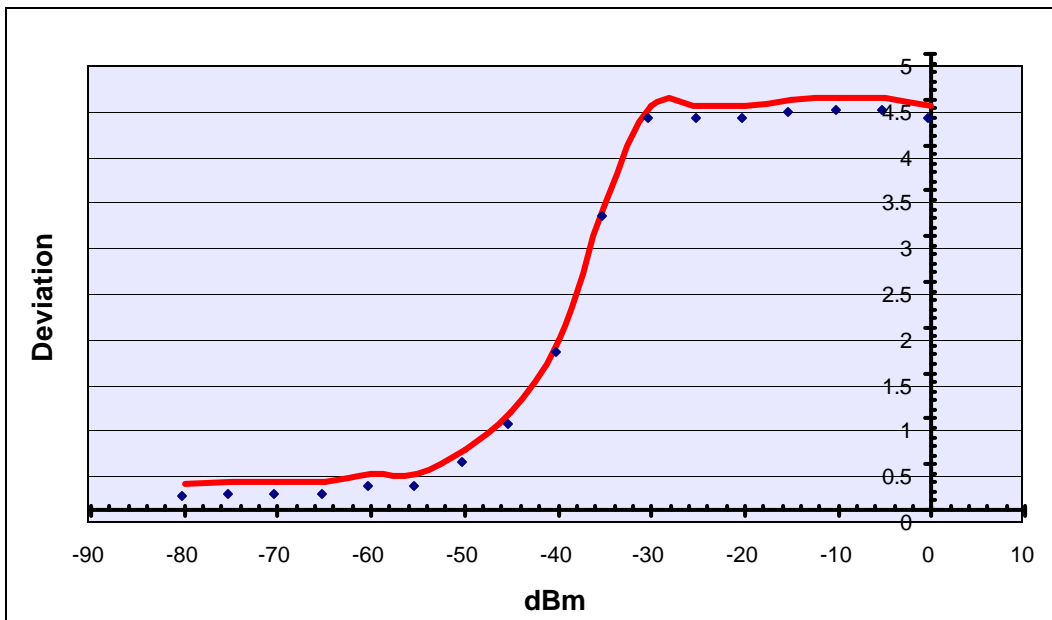

Modulation Limiting for 300Hz with 5.0kHz Dev.

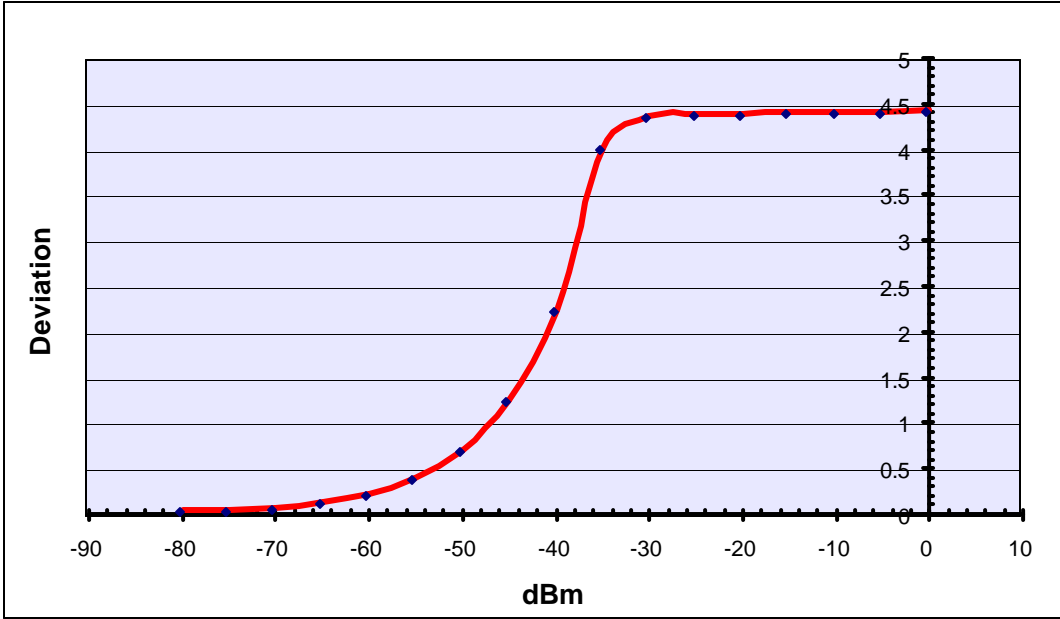

Modulation Limiting for 1000Hz with 5.0 kHz Dev.

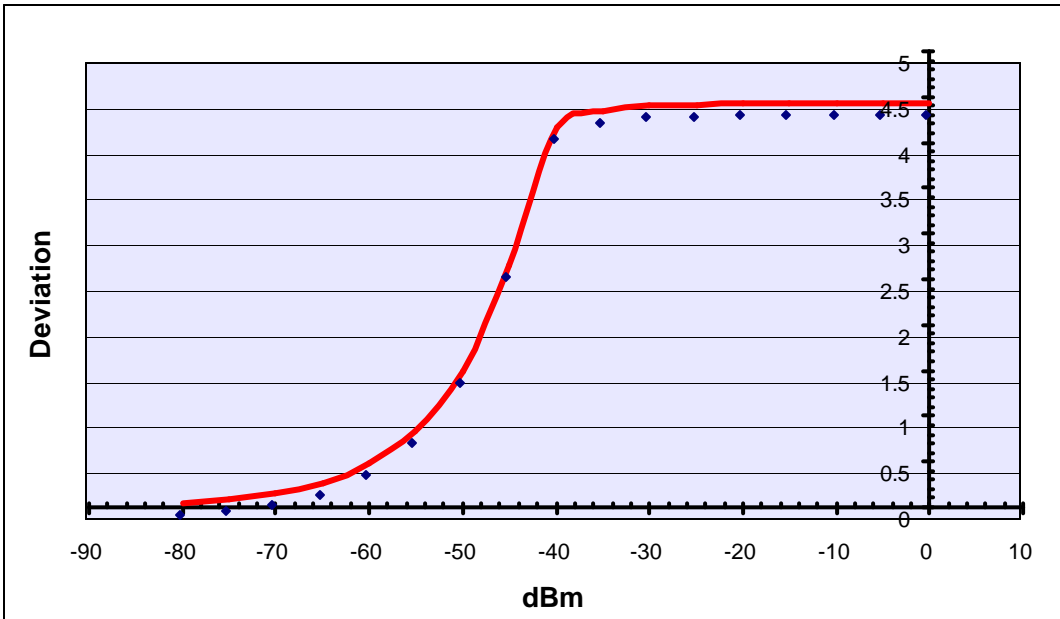

Modulation Limiting for 2500Hz with 5.0 kHz Dev.

Post Limiter Filter The filter must be between the modulation limiter and the modulated stage. At any frequency between 3 & 20 kHz the filter must have an attenuation of $60\log(f/3)$ greater than the attenuation at 1kHz. See the plot below.

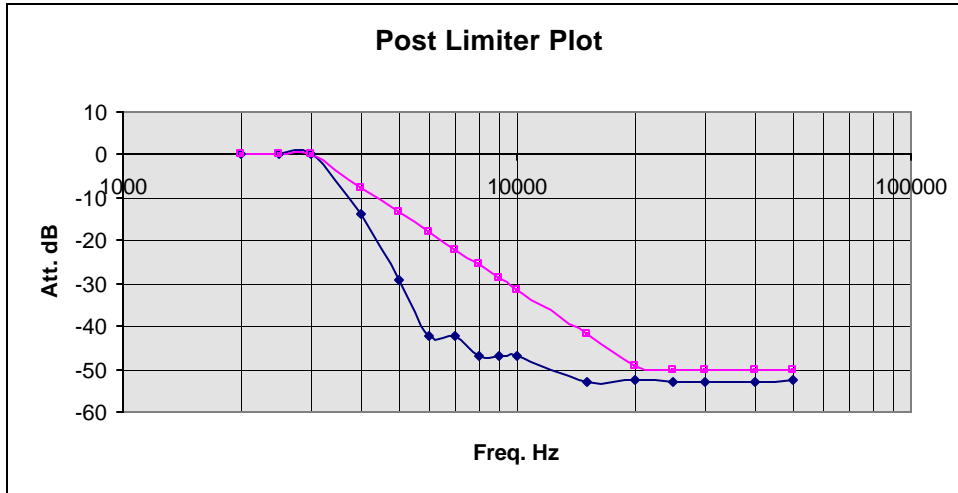

2.1049(c)
90.210(b)

EMISSION BANDWIDTH:

Data in the plots shows that the sidebands from greater than 50% to 100% of the authorized bandwidth must be attenuated by at least 25 dB and from 100 to 250% the sidebands must be attenuated by at least 35 dB. Beyond 250% the sidebands must be attenuated by at least $43 + \log_{10}(TP)$. The transmitter was modulated with 2500 Hz, adjusted for 50% modulation plus 16 dB. The spectrum analyzer was set with the unmodulated carrier at the top of the screen. The test procedure diagram follows. See the occupied bandwidth plots; pages 9, 10.

Radiotelephone transmitter with modulation limiter.

Test procedure diagram

OCCUPIED BANDWIDTH MEASUREMENT

Occupied BW Test Equipment Setup

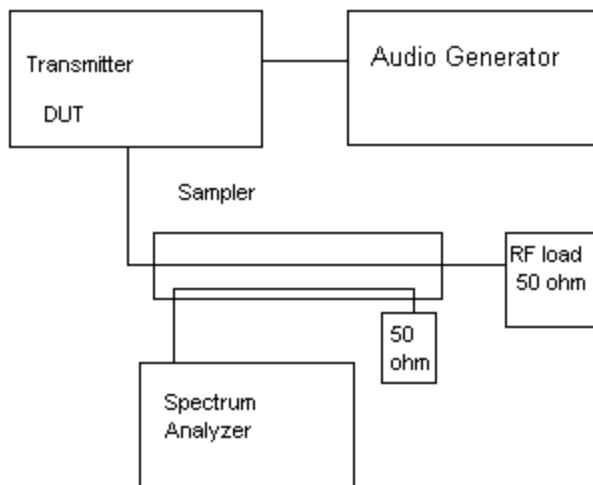

OCCUPIED BANDWIDTH PLOT - 20 kHz

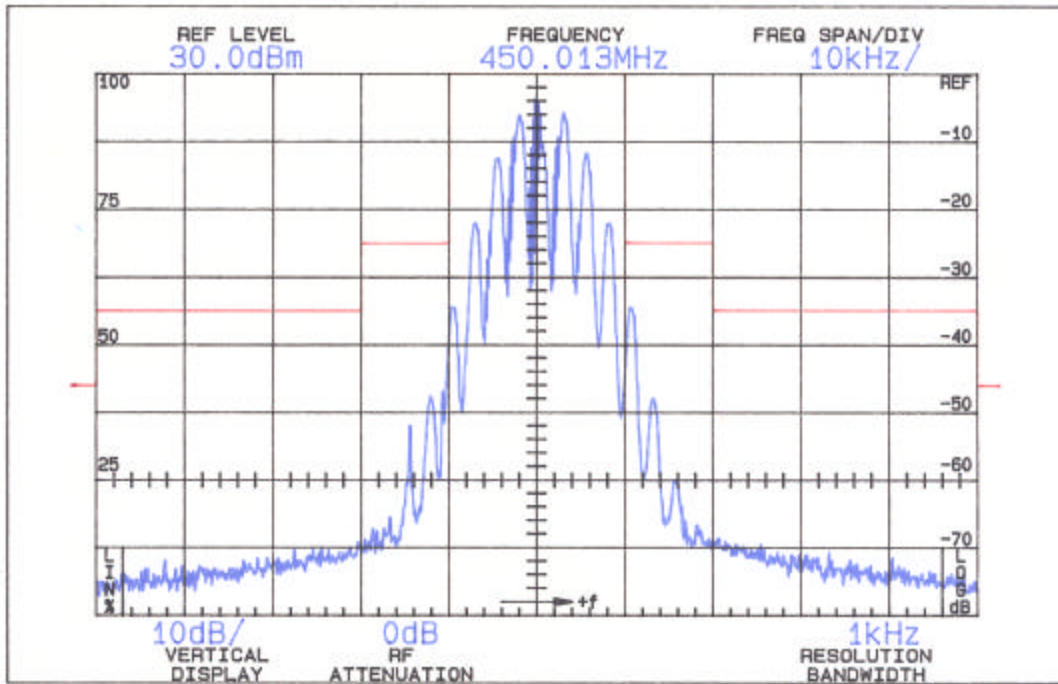

2.1051 Spurious emissions at antenna terminals(conducted):
 Data on the following page shows the level of conducted spurious responses. The carrier was modulated 100% using a 2500 Hz tone. The spectrum was scanned from 0.4 to at least the 10th harmonic of the fundamental. The measurements were made in accordance with standard TIA/EIA-603.

REQUIREMENTS: Emissions must be $50 + 10\log(P_o)$ dB below the mean power output of the transmitter.

HIGH POWER - $50 + 10\log(40) = 66.02$ dB

LOW POWER - $50 + 10\log(2) = 53.01$ dB

EMISSION FREQUENCY MHz	dB BELOW CARRIER	dB BELOW CARRIER
	LOW POWER	HIGH POWER
450.00	00.0	00.0
900.00	71.0	72.0
1350.00	73.0	77.0
1800.00	77.0	77.0
2250.00	77.0	77.0
470.00	00.0	00.0
940.00	69.0	72.0
1410.00	77.0	70.0
1800.00	77.0	77.0
489.00	00.0	00.0
979.97	73.0	66.0
1469.95	77.0	60.0
1959.85	77.0	77.0

Method of Measuring Conducted Spurious Emissions

Spurious Emissions at
Antenna Terminals

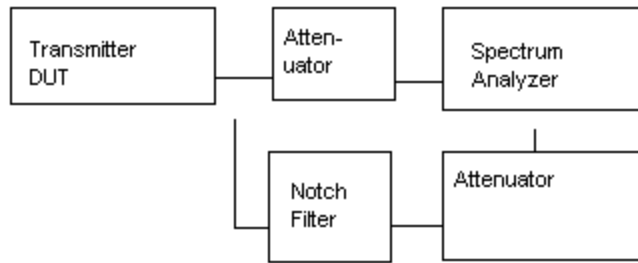

METHOD OF MEASUREMENT: The procedure used was TIA/EIA-603 STANDARD without any exceptions. An audio generator was connected to the UUT through a dummy microphone circuit and the output of the transmitter connected to a standard load and from the standard load through a pre-selector filter of the spectrum analyzer. The spectrum was scanned from 400 kHz to at least the tenth harmonic of the fundamental using a HP model 8566B spectrum analyzer. The measurements were made using the shielded room located at TIMCO ENGINEERING INC. 849 N.W. State Road 45, Newberry, Florida 32669.

2.1053 Field strength of spurious emissions:

NAME OF TEST: RADIATED SPURIOUS EMISSIONS

REQUIREMENTS: Emissions must be 50 +10log(Po) dB below the mean power output of the transmitter.

HIGH POWER - 50 + 10log(40) = 66 dB

LOW POWER - 50 + 10log(2) = 53 dB

TEST DATA:

Emission Frequency MHz	Field Strength dBuV/m	ATTN dBc	dBm
HIGH			
450.00	143.40	0	46
900.00	77.18	66	-20
1,350.00	69.96	73	-27
1,800.00	70.80	73	-27
2,250.00	73.57	70	-24
2,700.00	67.56	76	-30
3,150.00	67.10	76	-30
3,600.00	67.86	76	-30
4,050.00	68.24	75	-29
4,500.00	76.32	67	-21
LOW			
450.00	130.10	0	33
900.00	60.68	69	-36
1,350.00	68.26	62	-29
1,800.00	53.80	76	-43
2,250.00	62.97	67	-34
2,700.00	61.26	69	-36
3,150.00	62.50	68	-35
4,500.00	67.82	62	-29
HIGH			
470.00	143.40	0	46
940.00	73.50	70	-24
1,410.00	76.59	67	-21
1,880.00	70.94	72	-26
2,350.00	75.03	68	-22
2,820.00	67.79	76	-30
3,290.00	68.20	75	-29
3,760.00	70.63	73	-27
4,230.00	66.79	77	-31
4,700.00	72.68	71	-25

TEST DATA CONTINUED:

Emission Frequency MHz	Field Strength dBuV/m	ATTN dBc	dBm
LOW			
470.00	130.40	0	33
940.00	62.60	68	-35
1,410.00	75.92	54	-21
1,880.00	59.14	71	-38
2,350.00	61.93	68	-35
2,820.00	61.49	69	-36
3,290.00	63.00	67	-34
HIGH			
489.90	143.40	0	46
979.90	72.00	71	-25
1,469.90	76.44	67	-21
1,959.80	72.18	71	-25
2,449.80	70.50	73	-27
2,939.80	69.11	74	-28
3,429.70	69.11	74	-28
3,919.70	77.00	66	-20
4,409.70	76.14	67	-21
4,899.70	77.15	66	-20
LOW			
489.90	130.10	0	33
979.90	59.90	70	-37
1,469.90	74.39	56	-23
1,959.80	58.88	71	-38
2,449.80	67.30	63	-30
3,429.70	64.01	66	-33
4,409.70	68.04	97	-34

METHOD OF MEASUREMENTS: The tabulated data shows the results of the radiated field strength emissions test. The spectrum was scanned from 30 MHz to at least the tenth harmonic of the fundamental. This test was conducted per TIA/EIA STANDARD 603 using the substitution method. Measurements were made at the open field test site of TIMCO ENGINEERING, INC. located at 849 NW State Road 45, Newberry, FL 32669.

APPLICANT: TOPAZ3, LLC
 FCC ID: O7KML3245
 REPORT #: T/Topaz3LLC_F3J\1266AUT2\1266AUT2TestReport.doc
 Page 14 of 26

Method of Measuring Radiated Spurious Emissions

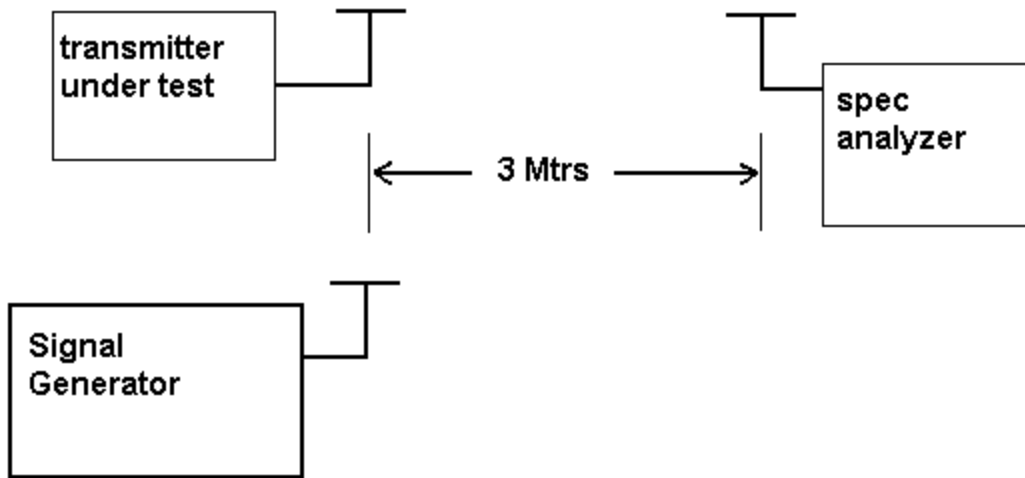

2.1055 Frequency stability:
90.213(a)(1)

Temperature and voltage tests were performed to verify that the frequency remains within the .00025%, 2.5 ppm specification limit. The EUT was placed in the temperature chamber at 25 degrees C and allowed to stabilize for one hour. The transmitter was keyed ON for one minute during which four frequency readings were recorded at 15 second intervals. The worse case number was taken for temperature plotting. The assigned channel frequency was considered to be the reference frequency. The temperature was then reduced to -30 degrees C after which the transmitter was again allowed to stabilize for one hour. The transmitter was keyed ON for one minute, and again frequency readings were noted at 15 second intervals. The worst case number was recorded for temperature plotting. This procedure was repeated in 10 degree increments up to + 50 degrees C.

Readings were also taken at minus 15% of the battery voltage of 13.6VDC, which we estimate to be the battery endpoint.

MEASUREMENT DATA:

Temperature C	Frequency Mhz	PPM
-29.50	450.013371	0.21
-19.60	450.013632	0.79
-9.50	450.013532	0.57
0.20	450.013275	0.00
9.80	450.013159	-0.26
19.90	450.013033	-0.54
30.40	450.012809	-1.04
40.00	450.012663	-1.36
49.90	450.012381	-1.99

Suply voltage %	suply voltage	PPM
1.15	15.64	0.18
1.10	14.96	0.13
1.05	14.28	0.06
0	0	0.00
0.95	13.60	-0.05
0.90	12.92	-0.10
0.85	12.24	-0.14
0.80	10.88	-0.18

REQUIREMENTS: In the 450-512 MHz frequency band, transient frequencies must be within the maximum frequency difference limits during the time interval indicated below for 12.5kHz Channels:

Time Interval	Maximum Frequency	Portable Radios 450-512 MHz
t1	+12.5 kHz	5.0 ms
t2	+6.25 kHz	20.0 ms
t3,t4	+12.5 kHz	5.0 ms

TEST PROCEEDURE: TIA/EIA TS603 PARA 2.2.19, the levels were set as follows;

1. Using the variable attenuator the transmitter level was set to 40 dB below the test receivers maximum input level, then the transmitter was turned off.
2. With the transmitter off the signal generator was set 20dB below the level of the transmitter in the above step, this level will be maintained with the signal generator through-out the test.
3. Reduce the attenuation between the transmitter and the RF detector by 30 dB.
4. With the levels set as above the transient frequency behavior was observed & recorded.

2.1055 Frequency stability:
90.214 Transient Frequency Behavior
(Continued)

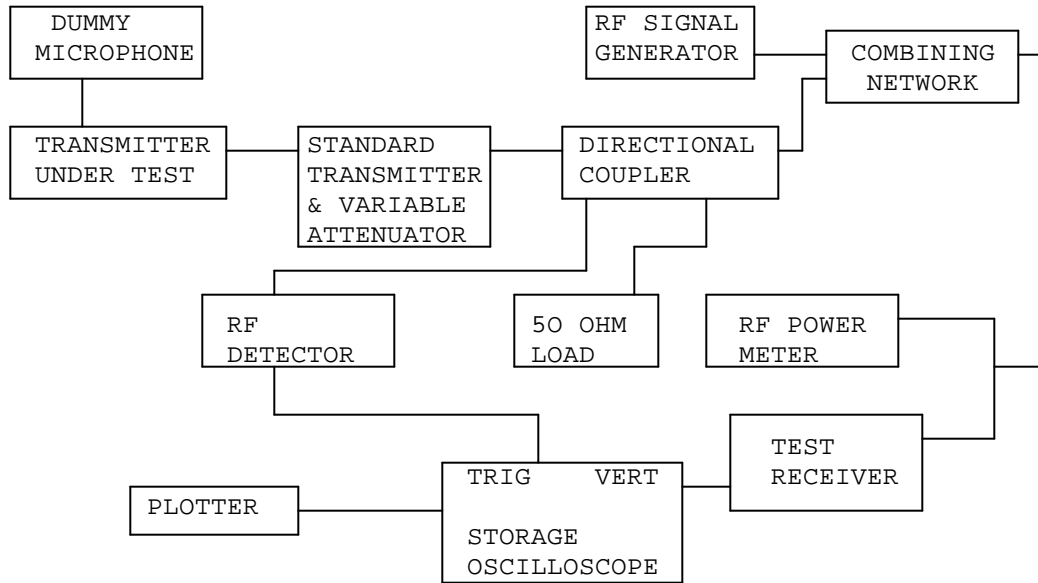

Name of Test: Transient Frequency behavior.
Reference Generator = 12.5 kHz Deviation
State: High Power
Turn-On Time Measurement

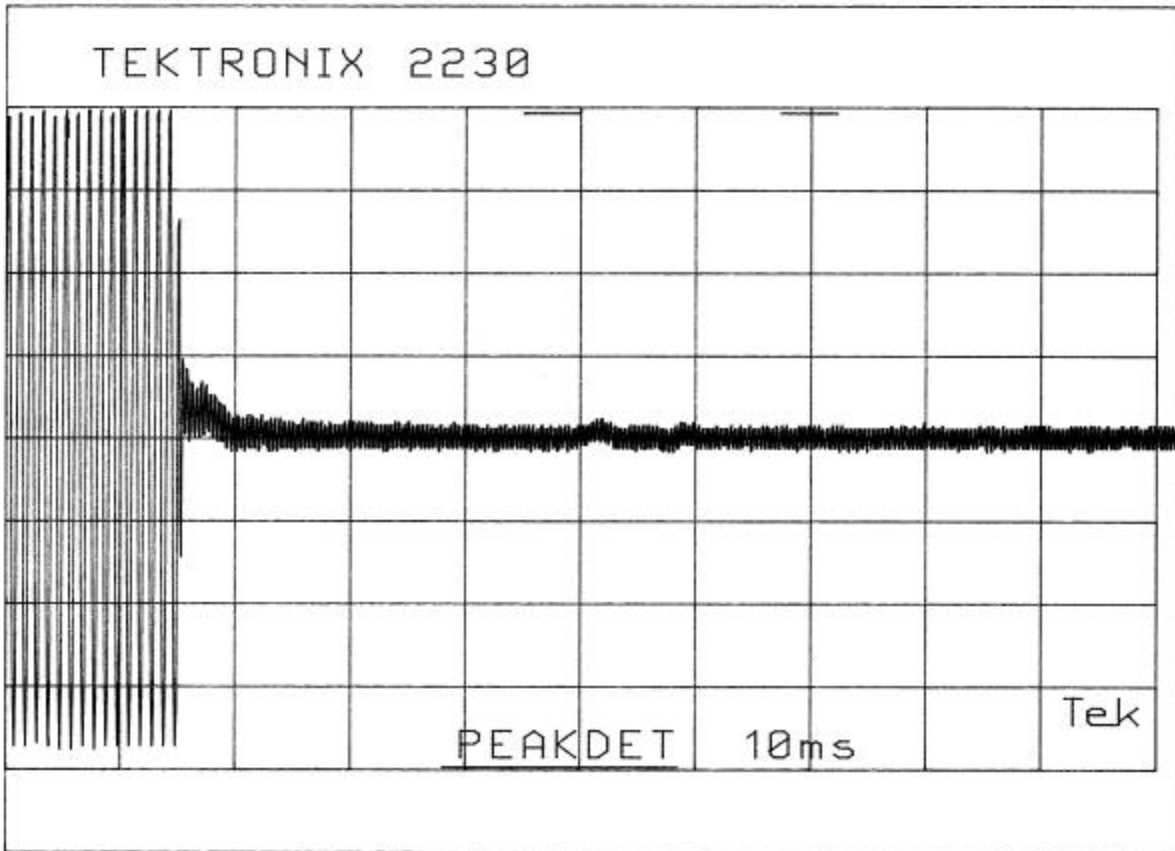

Name of Test: Transient Frequency behavior.
Reference Generator = 12.5 kHz Deviation
State: High Power
Turn-Off Time Measurement

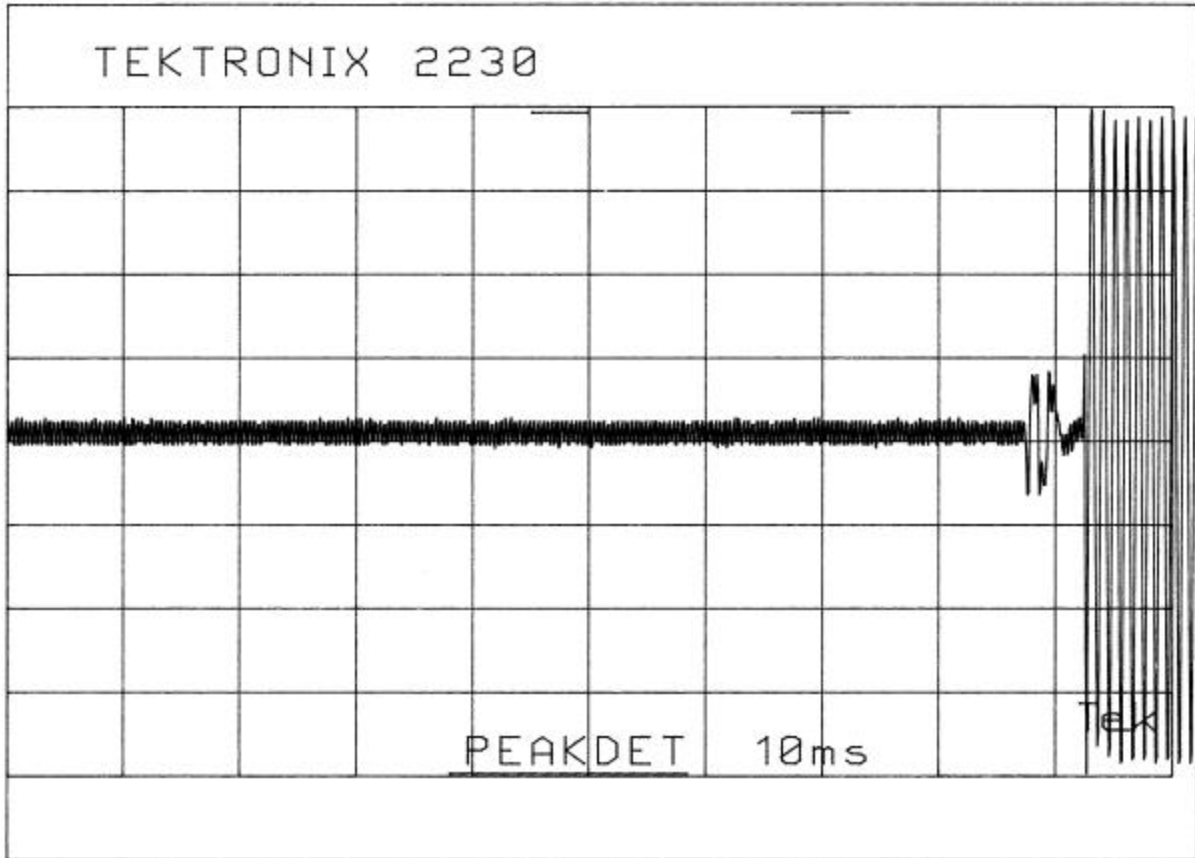

Name of Test: Transient Frequency behavior.
Reference Generator = 12.5 kHz Deviation
State: Low Power
Turn-On Time Measurement

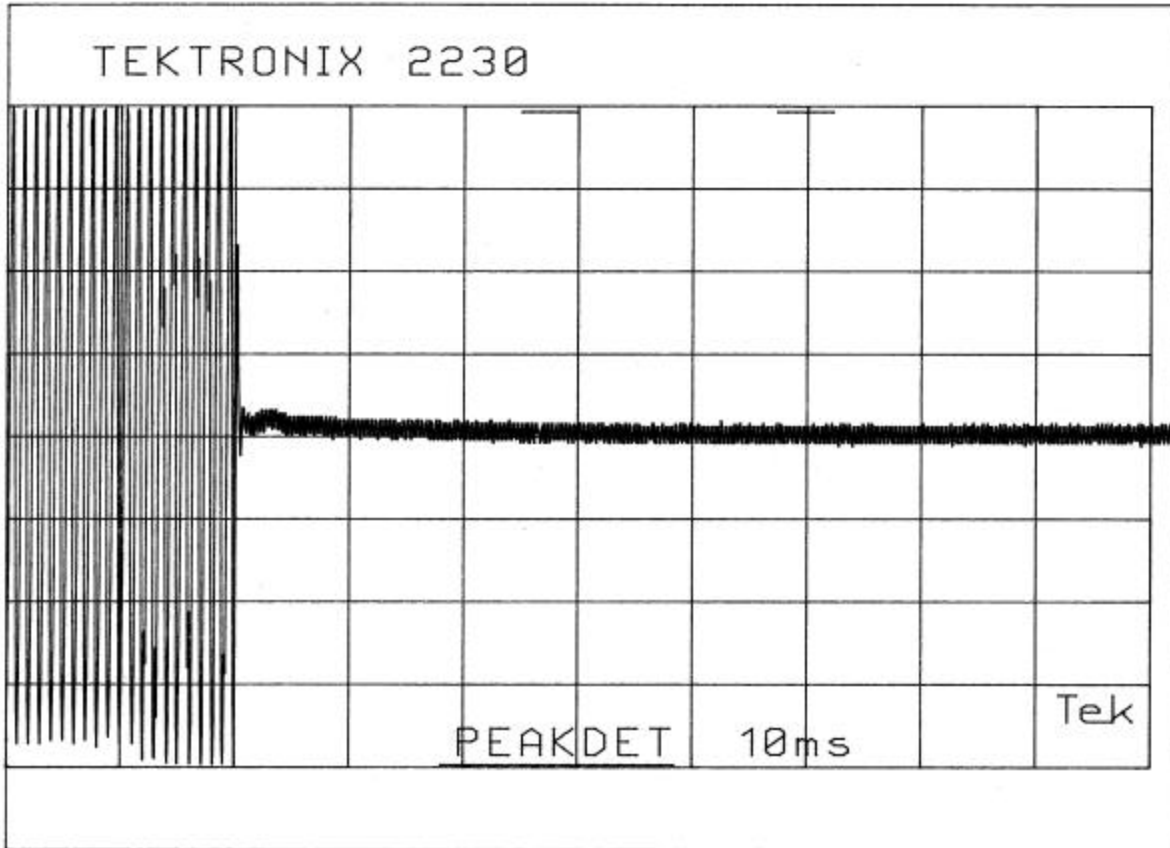

Name of Test: Transient Frequency behavior.
Reference Generator = 12.5 kHz Deviation
State: Low Power
Turn-Off Time Measurement

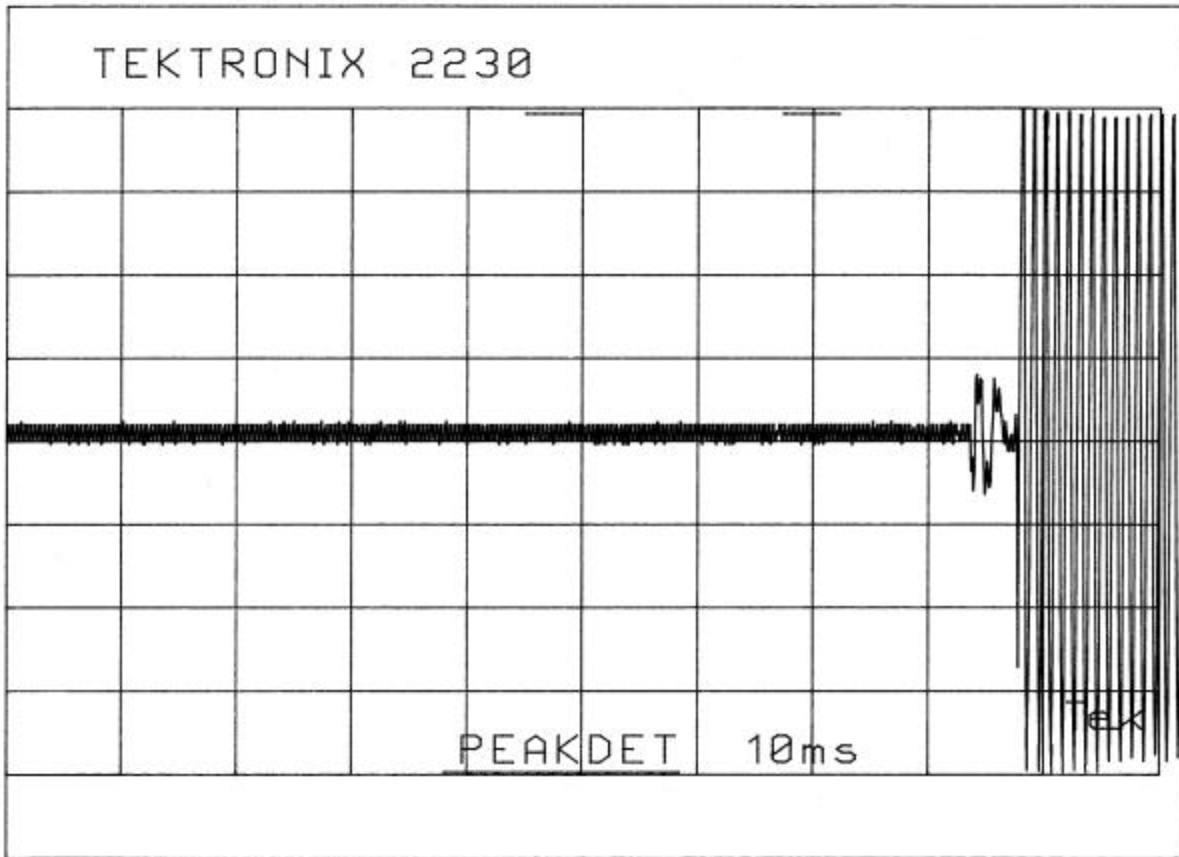

MPE CALCULATION

POWER OUTPUT: 40 Watts
DUTY CYCLE: 50%
FREQUENCY RANGE: 450 – 512 MHz
ANTENNA GAIN: 0dBd
Uncontrolled exposure environment
Per guide OET 65:

W := 40.0 power in Watts D := 1 Duty Factor in decimal % (1=100%)

E := 15 exposure time in minutes U := 30 (use 6 for controlled and 30 for uncontrolled)

$$W_{exp} := W \cdot D \cdot \left(\frac{E}{U} \right)$$

$$PC := \frac{E}{U}$$

PC = 0.5 percent on time

W_{exp} = 20 Watts

Po := 20000 mWatts dBd := 0 antenna gain f := 480 Frequency in MHz

G := dBd + 2.15 gain in dBi

Gn := 10 ^{$\frac{G}{10}$} gain numeric

$$S := \frac{f}{1500}$$

S is f/1500 for uncontrolled exposure.

Gn = 1.641

S = 0.32

$$R := \sqrt{\frac{(Po \cdot Gn)}{(4 \cdot \pi \cdot S)}}$$

$$R_{inches} := \frac{R}{2.54}$$

R = 90.331 distance in centimeters
required for compliance

Rinches = 35.563

EMC Equipment List

	DEVICE	MFGR	MODEL	SERNO	CAL/CHAR DATE	DUE DATE or STATUS
X	3-Meter OATS	TEI	N/A	N/A	Listed 12/22/99	12/22/02
	3/10-Meter OATS	TEI	N/A	N/A	Listed 3/26/01	3/26/04
	Receiver, Beige Tower Spectrum Analyzer (Tan)	HP	8566B Opt 462	3138A07786 3144A20661	CAL 8/31/01	8/31/03
	RF Preselector (Tan)	HP	85685A	3221A01400	CAL 8/31/01	8/31/03
	Quasi-Peak Adapter (Tan)	HP	85650A	3303A01690	CAL 8/31/01	8/31/03
X	Receiver, Blue Tower Spectrum Analyzer (Blue)	HP	8568B	2928A04729 2848A18049	CHAR 10/22/01	10/22/03
X	RF Preselector (Blue)	HP	85685A	2926A00983	CHAR 10/22/01	10/22/03
X	Quasi-Peak Adapter (Blue)	HP	85650A	2811A01279	CHAR 10/22/01	10/22/03
X	Biconnical Antenna	Electro-Metrics	BIA-25	1171	CAL 4/26/01	4/26/03
	Biconnical Antenna	Eaton	94455-1	1096	CAL 10/1/01	10/1/03
	Biconnical Antenna	Eaton	94455-1	1057	CHAR 3/15/00	3/15/02
	BiconiLog Antenna	EMCO	3143	9409-1043		
X	Log-Periodic Antenna	Electro-Metrics	LPA-25	1122	CAL 10/2/01	10/2/03
	Log-Periodic Antenna	Electro-Metrics	EM-6950	632	CHAR 10/15/01	10/15/03
	Log-Periodic Antenna	Electro-Metrics	LPA-30	409	CHAR 10/16/01	10/16/03
	Dipole Antenna Kit	Electro-Metrics	TDA-30/1-4	152	CAL 3/21/01	3/21/04
	Dipole Antenna Kit	Electro-Metrics	TDA-30/1-4	153	CHAR 11/24/00	11/24/03
	Double-Ridged Horn Antenna	Electro-Metrics	RGA-180	2319	CAL 12/19/01	12/19/03
	Horn Antenna	Electro-Metrics	EM-6961	6246	CAL 3/21/01	3/21/03
	Horn Antenna	ATM	19-443-6R	None	No Cal Required	

	DEVICE	MFGR	MODEL	SERNO	CAL/CHAR DATE	DUE DATE or STATUS
	Passive Loop Antenna	EMC Test Systems	EMCO 6512	9706-1211	CHAR 7/10/01	7/10/03
	Line Impedance Stabilization . . .	Electro-Metrics	ANS-25/2	2604	CAL 10/9/01	10/9/03
	Line Impedance Stabilization . . .	Electro-Metrics	EM-7820	2682	CAL 3/16/01	3/16/03
	Termaline Wattmeter	Bird Electronic Corporation	611	16405	CAL 5/25/99	5/25/01
	Termaline Wattmeter	Bird Electronic Corporation	6104	1926	CAL 12/12/01	12/12/03
	Oscilloscope	Tektronix	2230	300572	CHAR 2/1/01	2/1/03
X	Temperature Chamber	Tenney Engineering	TTRC	11717-7	CHAR 1/22/02	1/22/04
X	AC Voltmeter	HP	400FL	2213A14499	CAL 10/9/01	10/9/03
	AC Voltmeter	HP	400FL	2213A14261	CHAR 10/15/01	10/15/03
	AC Voltmeter	HP	400FL	2213A14728	CHAR 10/15/01	10/15/03
X	Digital Multimeter	Fluke	77	35053830	CHAR 1/8/02	1/8/04
	Digital Multimeter	Fluke	77	43850817	CHAR 1/8/02	1/8/04
	Digital Multimeter	HP	E2377A	2927J05849	CHAR 1/8/02	1/8/04
	Multimeter	Fluke	FLUKE-77-3	79510405	CAL 9/26/01	9/26/03
	Peak Power Meter	HP	8900C	2131A00545	CHAR 1/26/01	1/26/03
	Digital Thermometer	Fluke	2166A	42032	CAL 1/16/02	1/16/04
	Thermometer	Traulsen	SK-128		CHAR 1/22/02	1/22/04
X	Temp/Humidity gauge	EXTech	44577F	E000901	CHAR 1/22/02	1/22/04
	Frequency Counter	HP	5352B	2632A00165	CAL 11/28/01	11/28/03
	Power Sensor	Agilent Technologies	84811A	2551A02705	CAL 1/26/01	1/26/03
	Service Monitor	IFR	FM/AM 500A	5182	CAL 11/22/00	11/22/02
	Comm. Serv. Monitor	IFR	FM/AM 1200S	6593	CAL 5/12/02	5/12/04
	Signal Generator	HP	8640B	2308A21464	CAL 11/15/01	11/15/03
	Modulation Analyzer	HP	8901A	3435A06868	CAL 9/5/01	9/5/03

APPLICANT: TOPAZ3, LLC

FCC ID: 07KML3245

REPORT #: T/Topaz3LLC_F3J\1266AUT2\1266AUT2TestReport.doc

	DEVICE	MFGR	MODEL	SERNO	CAL/CHAR DATE	DUE DATE or STATUS
	Near Field Probe	HP	HP11940A	2650A02748	CHAR 2/1/01	2/1/03
	BandReject Filter	Lorch Microwave	5BR4-2400/ 60-N	Z1	CHAR 3/2/01	3/2/03
	BandReject Filter	Lorch Microwave	6BR6-2442/ 300-N	Z1	CHAR 3/2/01	3/2/03
	BandReject Filter	Lorch Microwave	5BR4-10525/ 900-S	Z1	CHAR 3/2/01	3/2/03
	High Pas Filter	Microlab	HA-10N		CHAR 10/4/01	10/4/03
	Audio Oscillator	HP	653A	832-00260	CHAR 3/1/01	3/1/03
	Frequency Counter	HP	5382A	1620A03535	CHAR 3/2/01	3/2/03
	Frequency Counter	HP	5385A	3242A07460	CHAR 12/11/01	12/11/03
	Preamplifier	HP	8449B-H02	3008A00372	CHAR 3/4/01	3/4/03
	Amplifier	HP	11975A	2738A01969	CHAR 3/1/01	3/1/03
	Egg Timer	Unk			CHAR 8/31/01	8/31/03
	Measuring Tape, 20M	Kraftixx	0631-20		CHAR 2/1/02	2/1/04
	Measuring Tape, 7.5M	Kraftixx	7.5M PROFI		2/1/02	2/1/04
	Coaxial Cable #51	Insulated Wire Inc.	NPS 2251-2880	Timco #51	CHAR 1/23/02	1/23/04
	Coaxial Cable #64	Semflex Inc.	60637	Timco #64	CHAR 1/24/02	1/24/04
	Coaxial Cable #65	General Cable Co.	E9917 RG233/U	Timco #65	CHAR 1/23/02	1/23/04
	Coaxial Cable #106	Unknown	Unknown	Timco #106	CHAR 1/23/02	1/23/04

APPLICANT: TOPAZ3, LLC
 FCC ID: 07KML3245
 REPORT #: T/Topaz3LLC_F3J\1266AUT2\1266AUT2TestReport.doc
 Page 26 of 26