



FCC TEST REPORT

REPORT NO.: RF930304R02
MODEL NO.: WL 01 2454 NM1 (Refer to page 6 for the other models)
RECEIVED: March 4, 2004
TESTED: March 17 ~ 18, 2004

APPLICANT: GLOBAL SUN TECHNOLOGY INC.

ADDRESS: NO.13, Tung Yuan Rd., Jung Li Industrial Park,
Jung Li City, Tao Yuan Hsien, Taiwan, R.O.C.

ISSUED BY: Advance Data Technology Corporation

LAB LOCATION: 47 14th Lin, Chiapau Tsun, Linko, Taipei,
Taiwan, R.O.C.

This test report consists of 65 pages in total. It may be duplicated completely for legal use with the approval of the applicant. It should not be reproduced except in full, without the written approval of our laboratory. The client should not use it to claim product endorsement by CNLA or any government agencies. The test results in the report only apply to the tested sample.



0528
ILAC MRA



Table of Contents

1	CERTIFICATION	4
2	SUMMARY OF TEST RESULTS	5
3	GENERAL INFORMATION	6
3.1	GENERAL DESCRIPTION OF EUT	6
3.2	DESCRIPTION OF TEST MODES	7
3.3	GENERAL DESCRIPTION OF APPLIED STANDARDS	7
3.4	DESCRIPTION OF SUPPORT UNITS	8
3.5	CONFIGURATION OF SYSTEM UNDER TEST	8
4	TEST TYPES AND RESULTS	9
4.1	CONDUCTED EMISSION MEASUREMENT	9
4.1.1	LIMITS OF CONDUCTED EMISSION MEASUREMENT	9
4.1.2	TEST INSTRUMENTS	9
4.1.3	TEST PROCEDURES	10
4.1.4	DEVIATION FROM TEST STANDARD	10
4.1.5	TEST SETUP	11
4.1.6	EUT OPERATING CONDITIONS	12
4.1.7	TEST RESULTS	13
4.2	RADIATED EMISSION MEASUREMENT	19
4.2.1	LIMITS OF RADIATED EMISSION MEASUREMENT	19
4.2.2	TEST INSTRUMENTS	20
4.2.3	TEST PROCEDURES	21
4.2.4	DEVIATION FROM TEST STANDARD	21
4.2.5	TEST SETUP	22
4.2.6	EUT OPERATING CONDITIONS	22
4.2.7	TEST RESULTS	23
4.2.8	TEST RESULTS (A)	25
4.2.9	TEST RESULTS (B)	28
4.3	6dB BANDWIDTH MEASUREMENT	31
4.3.1	LIMITS OF 6dB BANDWIDTH MEASUREMENT	31
4.3.2	TEST INSTRUMENTS	31
4.3.3	TEST PROCEDURE	32
4.3.4	DEVIATION FROM TEST STANDARD	32
4.3.5	TEST SETUP	32
4.3.6	EUT OPERATING CONDITIONS	32
4.3.7	TEST RESULTS (A)	33



4.3.8	TEST RESULTS (B)	37
4.4	MAXIMUM PEAK OUTPUT POWER	41
4.4.1	LIMITS OF MAXIMUM PEAK OUTPUT POWER MEASUREMENT	41
4.4.2	TEST INSTRUMENTS	41
4.4.3	TEST PROCEDURES	42
4.4.4	DEVIATION FROM TEST STANDARD	42
4.4.5	TEST SETUP	42
4.4.6	EUT OPERATING CONDITIONS	42
4.4.7	TEST RESULTS (A)	43
4.4.8	TEST RESULTS (B)	44
4.5	POWER SPECTRAL DENSITY MEASUREMENT	45
4.5.1	LIMITS OF POWER SPECTRAL DENSITY MEASUREMENT	45
4.5.2	TEST INSTRUMENTS	45
4.5.3	TEST PROCEDURE	46
4.5.4	DEVIATION FROM TEST STANDARD	46
4.5.5	TEST SETUP	46
4.5.6	EUT OPERATING CONDITIONS	46
4.5.7	TEST RESULTS (A)	47
4.5.8	TEST RESULTS (B)	51
4.6	BAND EDGES MEASUREMENT	55
4.6.1	LIMITS OF BAND EDGES MEASUREMENT	55
4.6.2	TEST INSTRUMENTS	55
4.6.3	TEST PROCEDURE	55
4.6.4	DEVIATION FROM TEST STANDARD	55
4.6.5	EUT OPERATING CONDITION	55
4.6.6	TEST RESULTS (A)	56
4.6.7	TEST RESULTS (B)	59
4.7	ANTENNA REQUIREMENT	62
4.7.1	STANDARD APPLICABLE	62
4.7.2	ANTENNA CONNECTED CONSTRUCTION	62
5	PHOTOGRAPHS OF THE TEST CONFIGURATION	63
6	INFORMATION ON THE TESTING LABORATORIES	65



1 CERTIFICATION

PRODUCT : 802.11g 54Mbps Wireless LAN Card
BRAND NAME : GLOBAL SUN (Refer to page 6 for the other brands)
MODEL NO. : WL 01 2454 NM1 (Refer to page 6 for the other models)
TEST ITEM: ENGINEERING SAMPLE
APPLICANT : GLOBAL SUN TECHNOLOGY CO., LTD.
STANDARDS : FCC Part 15, Subpart C (Section 15.247), ANSI C63.4-1992

We, **Advance Data Technology Corporation**, hereby certify that one sample of the designation has been tested in our facility from March 17 to March 18, 2004. The test record, data evaluation and Equipment Under Test (EUT) configurations represented herein are true and accurate accounts of the measurements of the sample's EMC characteristics under the conditions herein specified.

PREPARED BY: Suntee Liu, **DATE:** March 23, 2004
Suntee Liu

APPROVED BY: Ellis Wu, **DATE:** March 23, 2004
Ellis Wu /
Manager



2 SUMMARY OF TEST RESULTS

The EUT has been tested according to the following specifications:

APPLIED STANDARD: FCC Part 15, Subpart C			
Standard Section	Test Type and Limit	Result	REMARK
15.207	AC Power Conducted Emission	PASS	Meet the requirement of limit Minimum passing margin is -16.87dB at 0.179MHz
15.247(a)(2)	Spectrum Bandwidth of a Direct Sequence Spread Spectrum System Limit: min. 500kHz	PASS	Meet the requirement of limit
15.247(b)	Maximum Peak Output Power Limit: max. 30dBm	PASS	Meet the requirement of limit
15.247(c)	Transmitter Radiated Emissions Limit: Table 15.209	PASS	Meet the requirement of limit Minimum passing margin is -1.21dB at 2488.00MHz
15.247(d)	Power Spectral Density Limit: max. 8dBm	PASS	Meet the requirement of limit
15.247(c)	Band Edge Measurement Limit: 20 dB less than the peak value of fundamental frequency	PASS	Meet the requirement of limit

Note: The information of measurement uncertainty is available upon the customer's request.



3 GENERAL INFORMATION

3.1 GENERAL DESCRIPTION OF EUT

PRODUCT	802.11g 54Mbps Wireless LAN Card
MODEL NO.	WL 01 2454 NM1
BRAND NAME	GLOBAL SUN
POWER SUPPLY	3.3Vdc from host equipment
MODULATION TYPE	BPSK, QPSK, CCK, 16QAM, 64QAM
RADIO TECHNOLOGY	DSSS, OFDM
TRANSFER RATE	802.11b:11/5.5/2/1Mbps 802.11g: 54/48/36/24/18/12/9/6Mbps
FREQUENCY RANGE	2412MHz ~ 2462MHz
NUMBER OF CHANNEL	11
OUTPUT POWER	17.39dBm
ANTENNA TYPE	Printed antenna with 0dBi gain
DATA CABLE	NA
I/O PORTS	NA
ASSOCIATED DEVICES	NA

NOTE:

1. This report is prepared for FCC II permissive change. The difference compared with the original design is changing the antenna gain to the EUT.
2. This report is issued as a supplementary report of ADT report no.: 921127R01A. The model name and brand name are different to the original one.
3. Conduction and radiation had been re-tested in this report.
4. The EUT operates in the 2.4GHz frequency spectrum with throughput of up to 54Mbps.
5. The EUT complies with IEEE 802.11g draft standards and backwards compatible with IEEE 802.11b products.
6. The models as below are identical to each other except their model and brand name due to marketing requirement.

Brand	Model
PLANEX/PCI	GW-NS54GMX
Topcom	Skыр@cer PC Card 3154G
ORIGO	WLL-3210M
PLANET	WL-3561
AOpen	AOI-812
Q-Tec	Q-TEC PC-CARD WIRELESS 54G
Level One	Marvell 11g PC Card
Etherwan Systems Inc.	EWP-0202-G

7. For more detailed features description, please refer to the manufacturer's specifications or User's Manual.



3.2 DESCRIPTION OF TEST MODES

Eleven channels are provided to this EUT.

Channel	Frequency	Channel	Frequency
1	2412 MHz	7	2442 MHz
2	2417 MHz	8	2447 MHz
3	2422 MHz	9	2452 MHz
4	2427 MHz	10	2457 MHz
5	2432 MHz	11	2462 MHz
6	2437 MHz		

NOTE:

1. Below 1GHz, the channel 1, 6, and 11 were pre-tested in chamber. The channel 11, the worst case, was chosen for final test.
2. Above 1GHz, the channel 1, 6, and 11 were tested individually.
3. Transfer rate, 6Mbps with OFDM technique, the worst case, was chosen for final test.
4. Two test results are presented in the following sections. The test results A is for CCK technique and the test results B is for OFDM technique.

3.3 GENERAL DESCRIPTION OF APPLIED STANDARDS

The EUT is an 802.11g 54Mbps Wireless LAN Card. According to the specifications of the manufacturer, it must comply with the requirements of the following standards:

FCC Part 15, Subpart C. (15.247)
ANSI C63.4:1992

All test items have been performed and recorded as per the above standards.

NOTE: The EUT is also considered as a kind of computer peripheral, because the connection to computer is necessary for typical use. It has been verified to comply with the requirements of FCC Part 15, Subpart B, Class B (DoC). The test report has been issued separately.



3.4 DESCRIPTION OF SUPPORT UNITS

The EUT has been tested as an independent unit together with other necessary accessories or support units. The following support units or accessories were used to form a representative test configuration during the tests.

NO.	PRODUCT	BRAND	MODEL NO.	SERIAL NO.	FCC ID
1	NOTEBOOK	Dell	PP01L	TW-09C748-12800-16M-5064	FCC DoC Approved
2	MODEM	ACEEX	1414	980020536	IFAXDM1414
3	PRINTER	EPSON	LQ-300+	DCGY017076	FCC DoC Approved

NO.	SIGNAL CABLE DESCRIPTION OF THE ABOVE SUPPORT UNITS
1	NA
2	1.2 m braid shielded wire, terminated with DB25 and DB9 connector via metallic frame, w/o core.
3	1.2m braid shielded wire, terminated with DB25 and Centronics connector via metallic frame, w/o core

NOTE: All power cords of the above support units are non shielded (1.8m).

3.5 CONFIGURATION OF SYSTEM UNDER TEST

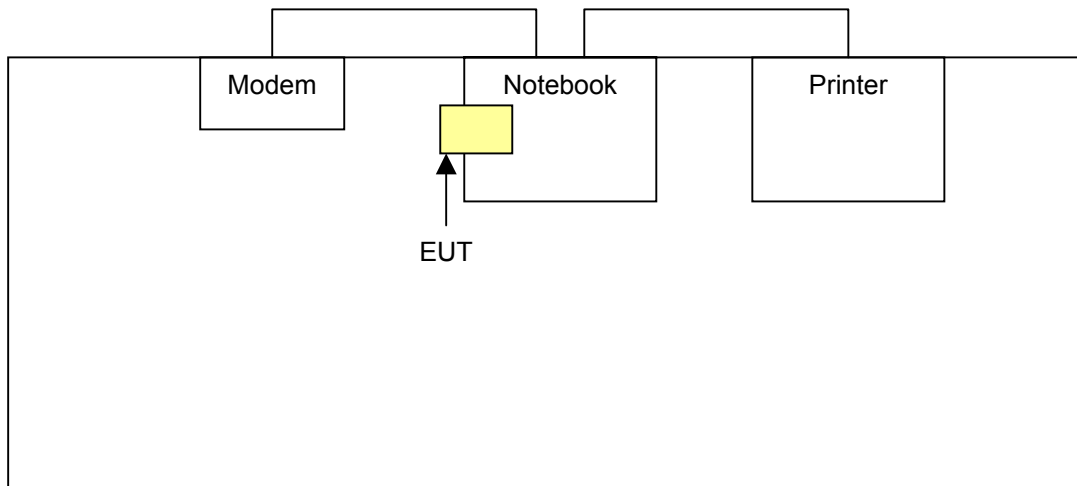



4 TEST TYPES AND RESULTS

4.1 CONDUCTED EMISSION MEASUREMENT

4.1.1 LIMITS OF CONDUCTED EMISSION MEASUREMENT

FREQUENCY OF EMISSION (MHz)	CONDUCTED LIMIT (dB μ V)	
	Quasi-peak	Average
0.15-0.5	66 to 56	56 to 46
0.5-5	56	46
5-30	60	50

- NOTE:**
1. The lower limit shall apply at the transition frequencies.
 2. The limit decreases in line with the logarithm of the frequency in the range of 0.15 to 0.50 MHz.
 3. All emanations from a class A/B digital device or system, including any network of conductors and apparatus connected thereto, shall not exceed the level of field strengths specified above.

4.1.2 TEST INSTRUMENTS

DESCRIPTION & MANUFACTURER	MODEL NO.	SERIAL NO.	CALIBRATED UNTIL
ROHDE & SCHWARZ Test Receiver	ESCS30	847793/022	Feb. 18, 2005
ROHDE & SCHWARZ Artificial Mains Network (for EUT)	ESH2-Z5	828075/003	July 08, 2004
ROHDE & SCHWARZ 200-A Four-line V-Network	ENV4200	830326/018	Oct. 02, 2004
* ROHDE & SCHWARZ 4-wire ISN	ENY41	838119/028	Nov. 16, 2004
* ROHDE & SCHWARZ 2-wire ISN	ENY22	837497/018	Nov. 16, 2004
EMCO-L.I.S.N. (for peripheral)	3825/2	9003-1627	July 08, 2004
Software	Cond-V2M3	NA	NA
RF cable (JYEBAO)	5D-FB	Cable-C05.01	May 23, 2004
LYNICS Terminator (For EMCO LISN)	0900510	E1-01-305	Feb. 22, 2005
LYNICS Terminator (For EMCO LISN)	0900510	E1-01-306	Feb. 22, 2005

- NOTE:**
1. The calibration interval of the above test instruments is 12 months and the calibrations are traceable to NML/ROC and NIST/USA.
 2. “*”: These equipment are used for conducted telecom port test only (if tested).
 3. The test was performed in ADT Shielded Room No. 5.
 4. The VCCI Site Registration No. is C-1093.



4.1.3 TEST PROCEDURES

- a. The EUT was placed 0.4 meters from the conducting wall of the shielded room with EUT being connected to the power mains through a line impedance stabilization network (LISN). Other support units were connected to the power mains through another LISN. The two LISNs provide 50 ohm/ 50uH of coupling impedance for the measuring instrument.
- b. Both lines of the power mains connected to the EUT were checked for maximum conducted interference.
- c. The frequency range from 150 kHz to 30 MHz was searched. Emission levels (Limit -20dBi) was not recorded.

4.1.4 DEVIATION FROM TEST STANDARD

No deviation

4.1.5 TEST SETUP

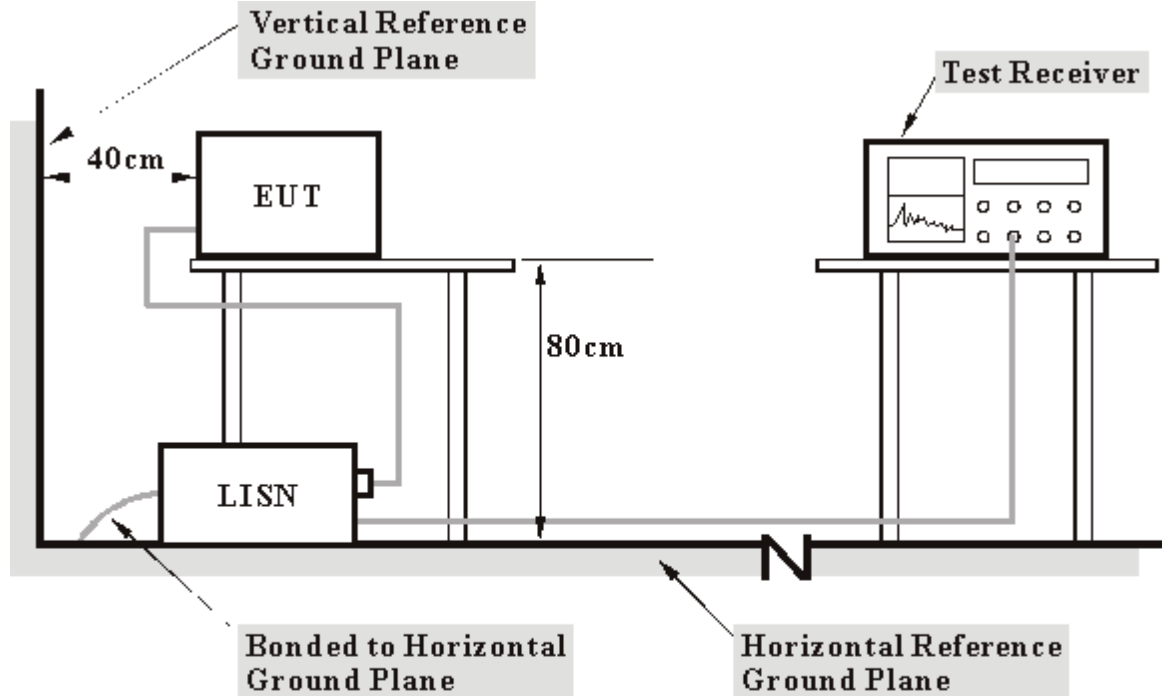

- Note:**
1. Support units were connected to second LISN.
 2. Both of LISNs (AMN) 80 cm from EUT and at the least 80 cm from other units and other metal planes support units.

For the actual test configuration, please refer to the related item – Photographs of the Test Configuration.



4.1.6 EUT OPERATING CONDITIONS

- a. Connected the EUT to a notebook system placed on a testing table.
- b. The notebook system ran a test program (provided by manufacturer) to enable EUT under transmission/receiving condition continuously at specific channel frequency.
- c. The computer system sent "H" messages to its screen.
- d. The computer system sent "H" messages to modem.
- e. The computer system sent "H" messages to printer, and the printer prints them on paper.
- f. Steps c~e were repeated.



4.1.7 TEST RESULTS

EUT	802.11g 54Mbps Wireless LAN Card	MODEL	WL 01 2454 NM1
MODE	Channel 1	6dB BANDWIDTH	9 kHz
INPUT POWER (SYSTEM)	120Vac, 60Hz	PHASE	Line (L)
ENVIRONMENTAL CONDITIONS	26deg. C, 78%RH, 991hPa	TESTED BY: Vincent Lin	

No	Freq. [MHz]	Corr. Factor (dB)	Reading Value		Emission Level		Limit		Margin	
			[dB (uV)]		[dB (uV)]		[dB (uV)]		(dB)	
			Q.P.	AV.	Q.P.	AV.	Q.P.	AV.	Q.P.	AV.
1	0.181	0.18	45.40	-	45.58	-	64.43	54.43	-18.85	-
2	0.236	0.20	39.83	-	40.03	-	62.24	52.24	-22.21	-
3	0.416	0.20	33.28	-	33.48	-	57.54	47.54	-24.05	-
4	3.992	0.40	30.80	-	31.20	-	56.00	46.00	-24.80	-
5	17.688	0.96	27.99	-	28.95	-	60.00	50.00	-31.05	-
6	28.656	1.37	26.04	-	27.41	-	60.00	50.00	-32.59	-

- REMARKS:**
1. Q.P. and AV. are abbreviations of quasi-peak and average individually.
 2. "-": The Quasi-peak reading value also meets average limit and measurement with the average detector is unnecessary.
 3. The emission levels of other frequencies were very low against the limit.
 4. Margin value = Emission level - Limit value
 5. Correction factor = Insertion loss + Cable loss
 6. Emission Level = Correction Factor + Reading Value.

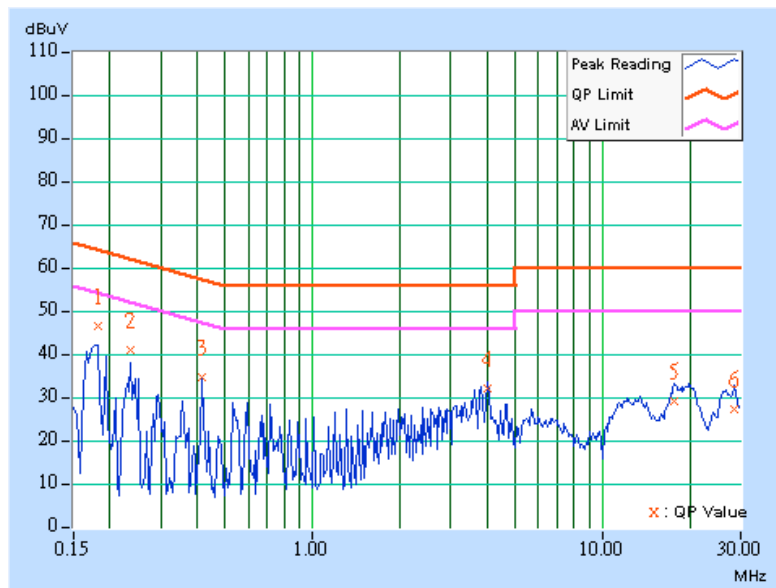



EUT	802.11g 54Mbps Wireless LAN Card	MODEL	WL 01 2454 NM1
MODE	Channel 1	6dB BANDWIDTH	9 kHz
INPUT POWER (SYSTEM)	120Vac, 60Hz	PHASE	Neutral (N)
ENVIRONMENTAL CONDITIONS	26deg. C, 78%RH, 991hPa	TESTED BY: Vincent Lin	

No	Freq. [MHz]	Corr. Factor (dB)	Reading Value [dB (uV)]		Emission Level [dB (uV)]		Limit [dB (uV)]		Margin (dB)	
			Q.P.	AV.	Q.P.	AV.	Q.P.	AV.	Q.P.	AV.
			1	0.179	0.18	45.70	-	45.88	-	64.55
2	0.240	0.20	39.81	-	40.01	-	62.10	52.10	-22.09	-
3	0.298	0.20	34.81	-	35.01	-	60.29	50.29	-25.28	-
4	3.813	0.40	33.82	-	34.22	-	56.00	46.00	-21.78	-
5	17.559	0.80	27.97	-	28.77	-	60.00	50.00	-31.23	-
6	19.938	1.00	26.11	-	27.11	-	60.00	50.00	-32.89	-

- REMARKS:**
1. Q.P. and AV. are abbreviations of quasi-peak and average individually.
 2. "-": The Quasi-peak reading value also meets average limit and measurement with the average detector is unnecessary.
 3. The emission levels of other frequencies were very low against the limit.
 4. Margin value = Emission level - Limit value
 5. Correction factor = Insertion loss + Cable loss
 6. Emission Level = Correction Factor + Reading Value.

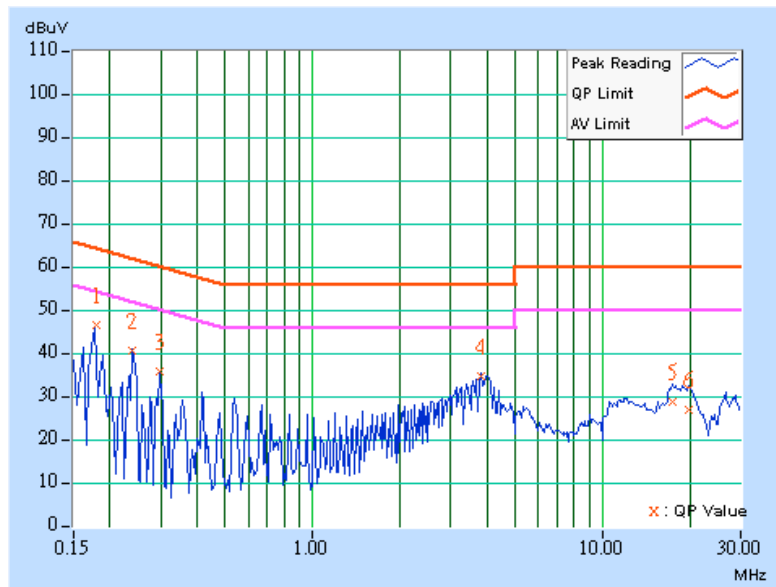



EUT	802.11g 54Mbps Wireless LAN Card	MODEL	WL 01 2454 NM1
MODE	Channel 6	6dB BANDWIDTH	9 kHz
INPUT POWER (SYSTEM)	120Vac, 60Hz	PHASE	Line (L)
ENVIRONMENTAL CONDITIONS	26deg. C, 78%RH, 991hPa	TESTED BY: Vincent Lin	

No	Freq. [MHz]	Corr. Factor (dB)	Reading Value		Emission Level		Limit		Margin	
			[dB (uV)]		[dB (uV)]		[dB (uV)]		(dB)	
			Q.P.	AV.	Q.P.	AV.	Q.P.	AV.	Q.P.	AV.
1	0.180	0.18	47.18	-	47.36	-	64.49	54.49	-17.13	-
2	0.240	0.20	41.25	-	41.45	-	62.11	52.11	-20.66	-
3	0.298	0.20	37.93	-	38.13	-	60.29	50.29	-22.16	-
4	3.754	0.40	31.14	-	31.54	-	56.00	46.00	-24.46	-
5	17.715	0.96	27.87	-	28.83	-	60.00	50.00	-31.17	-
6	20.441	1.12	28.20	-	29.32	-	60.00	50.00	-30.68	-

- REMARKS:**
1. Q.P. and AV. are abbreviations of quasi-peak and average individually.
 2. "-": The Quasi-peak reading value also meets average limit and measurement with the average detector is unnecessary.
 3. The emission levels of other frequencies were very low against the limit.
 4. Margin value = Emission level - Limit value
 5. Correction factor = Insertion loss + Cable loss
 6. Emission Level = Correction Factor + Reading Value.

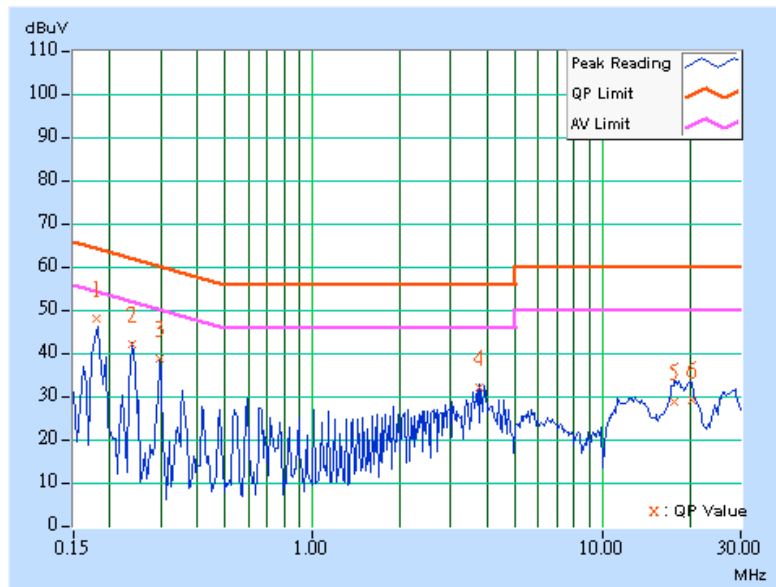



EUT	802.11g 54Mbps Wireless LAN Card	MODEL	WL 01 2454 NM1
MODE	Channel 6	6dB BANDWIDTH	9 kHz
INPUT POWER (SYSTEM)	120Vac, 60Hz	PHASE	Neutral (N)
ENVIRONMENTAL CONDITIONS	26deg. C, 78%RH, 991hPa	TESTED BY: Vincent Lin	

No	Freq. [MHz]	Corr. Factor (dB)	Reading Value [dB (uV)]		Emission Level [dB (uV)]		Limit [dB (uV)]		Margin (dB)	
			Q.P.	AV.	Q.P.	AV.	Q.P.	AV.	Q.P.	AV.
			1	0.179	0.18	45.85	-	46.03	-	64.55
2	0.240	0.20	39.67	-	39.87	-	62.10	52.10	-22.23	-
3	0.298	0.20	35.14	-	35.34	-	60.29	50.29	-24.95	-
4	3.871	0.40	34.23	-	34.63	-	56.00	46.00	-21.37	-
5	17.499	0.80	27.48	-	28.28	-	60.00	50.00	-31.72	-
6	19.423	0.95	27.21	-	28.16	-	60.00	50.00	-31.84	-

- REMARKS:**
1. Q.P. and AV. are abbreviations of quasi-peak and average individually.
 2. "-": The Quasi-peak reading value also meets average limit and measurement with the average detector is unnecessary.
 3. The emission levels of other frequencies were very low against the limit.
 4. Margin value = Emission level - Limit value
 5. Correction factor = Insertion loss + Cable loss
 6. Emission Level = Correction Factor + Reading Value.

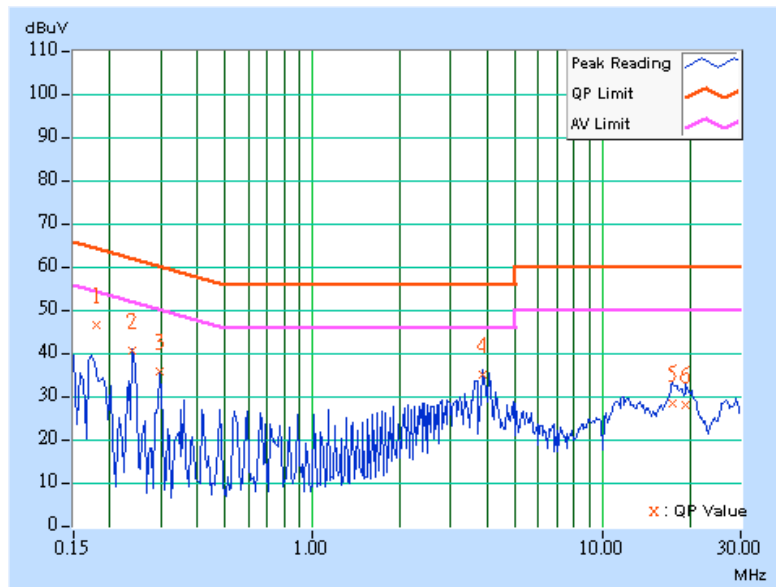



EUT	802.11g 54Mbps Wireless LAN Card	MODEL	WL 01 2454 NM1
MODE	Channel 11	6dB BANDWIDTH	9 kHz
INPUT POWER (SYSTEM)	120Vac, 60Hz	PHASE	Line (L)
ENVIRONMENTAL CONDITIONS	26deg. C, 78%RH, 991hPa	TESTED BY: Vincent Lin	

No	Freq. [MHz]	Corr. Factor (dB)	Reading Value		Emission Level		Limit		Margin	
			[dB (uV)]		[dB (uV)]		[dB (uV)]		(dB)	
			Q.P.	AV.	Q.P.	AV.	Q.P.	AV.	Q.P.	AV.
1	0.179	0.18	47.50	-	47.68	-	64.55	54.55	-16.87	-
2	0.240	0.20	41.09	-	41.29	-	62.10	52.10	-20.81	-
3	0.298	0.20	37.73	-	37.93	-	60.29	50.29	-22.36	-
4	3.992	0.40	30.92	-	31.32	-	56.00	46.00	-24.68	-
5	17.879	0.97	28.80	-	29.77	-	60.00	50.00	-30.23	-
6	28.676	1.37	26.25	-	27.62	-	60.00	50.00	-32.38	-

- REMARKS:**
1. Q.P. and AV. are abbreviations of quasi-peak and average individually.
 2. "-": The Quasi-peak reading value also meets average limit and measurement with the average detector is unnecessary.
 3. The emission levels of other frequencies were very low against the limit.
 4. Margin value = Emission level - Limit value
 5. Correction factor = Insertion loss + Cable loss
 6. Emission Level = Correction Factor + Reading Value.

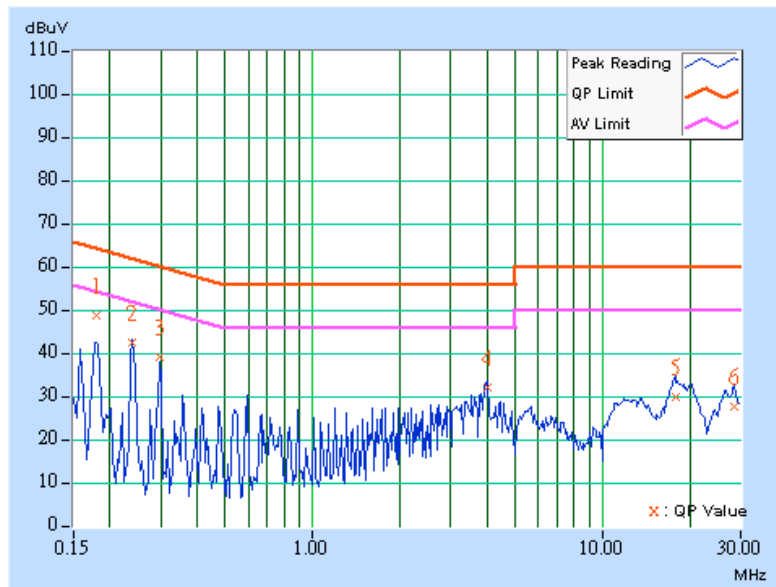



EUT	802.11g 54Mbps Wireless LAN Card	MODEL	WL 01 2454 NM1
MODE	Channel 11	6dB BANDWIDTH	9 kHz
INPUT POWER (SYSTEM)	120Vac, 60Hz	PHASE	Netural (N)
ENVIRONMENTAL CONDITIONS	26deg. C, 78%RH, 991hPa	TESTED BY: Vincent Lin	

No	Freq. [MHz]	Corr. Factor (dB)	Reading Value		Emission Level		Limit		Margin	
			[dB (uV)]		[dB (uV)]		[dB (uV)]		(dB)	
			Q.P.	AV.	Q.P.	AV.	Q.P.	AV.	Q.P.	AV.
1	0.177	0.18	45.35	-	45.53	-	64.61	54.61	-19.08	-
2	0.240	0.20	39.79	-	39.99	-	62.10	52.10	-22.11	-
3	0.298	0.20	35.12	-	35.32	-	60.29	50.29	-24.97	-
4	3.754	0.40	33.38	-	33.78	-	56.00	46.00	-22.22	-
5	17.992	0.84	27.78	-	28.62	-	60.00	50.00	-31.38	-
6	25.918	0.90	23.57	-	24.47	-	60.00	50.00	-35.53	-

- REMARKS:**
1. Q.P. and AV. are abbreviations of quasi-peak and average individually.
 2. "-": The Quasi-peak reading value also meets average limit and measurement with the average detector is unnecessary.
 3. The emission levels of other frequencies were very low against the limit.
 4. Margin value = Emission level - Limit value
 5. Correction factor = Insertion loss + Cable loss
 6. Emission Level = Correction Factor + Reading Value.

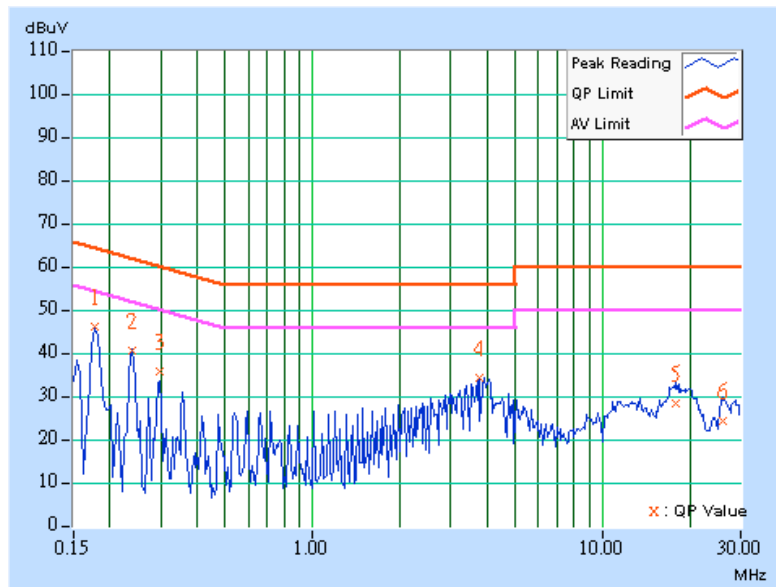



4.2 RADIATED EMISSION MEASUREMENT

4.2.1 LIMITS OF RADIATED EMISSION MEASUREMENT

Emissions radiated outside of the specified bands, shall be according to the general radiated limits in 15.209 as following:

Frequencies (MHz)	Field strength (microvolts/meter)	Measurement distance (meters)
0.009-0.490	2400/F(kHz)	300
0.490-1.705	24000/F(kHz)	30
1.705-30.0	30	30
30-88	100	3
88-216	150	3
216-960	200	3
Above 960	500	3

NOTE:

1. The lower limit shall apply at the transition frequencies.
2. Emission level (dBuV/m) = 20 log Emission level (uV/m).
3. As shown in 15.35(b), for frequencies above 1000MHz, the field strength limits are based on average detector, however, the peak field strength of any emission shall not exceed the maximum permitted average limits, specified above by more than 20dB under any condition of modulation.



4.2.2 TEST INSTRUMENTS

DESCRIPTION & MANUFACTURER	MODEL NO.	SERIAL NO.	CALIBRATED UNTIL
* HP Spectrum Analyzer	8590L	3544A01176	Jun. 10, 2004
* HP Preamplifier	8447D	2944A08485	May 01, 2004
* HP Spectrum Analyzer	8593E	3926A04191	Mar. 23, 2005
* HP Preamplifier	8449B	3008A01292	Aug. 13, 2004
ROHDE & SCHWARZ TEST RECEIVER	ESI7	838496/016	Feb. 08, 2005
* ROHDE & SCHWARZ TEST RECEIVER	ESMI	839013/007 839379/002	Feb. 12, 2005
SCHAFFNER Tunable Dipole Antenna	VHBA 9123	459	Jun. 26, 2004
SCHWARZBECK Tunable Dipole Antenna	UHA 9105	977	
* CHASE BILOG Antenna	CBL6112A	2221	Jul. 26, 2004
* SCHWARZBECK Horn Antenna	BBHA9120-D1	D130	Jun. 30, 2004
* EMCO Turn Table	1060	1115	NA
* CHANCE Tower	CM-AT40	CM-A010	NA
* Software	ADT_Radiated_V5.14	NA	NA
* ANRITSU RF Switches	MP59B	M35046	Oct. 9, 2004
* TIMES RF cable	LMR-600	CABLE-ST5-01	Oct. 9, 2004

NOTE: 1. The calibration interval of the above test instruments is 12 months. And the calibrations are traceable to NML/ROC and NIST/USA.

2. "*" = These equipment are used for the final measurement.
3. The horn antenna and HP preamplifier (model: 8449B) are used only for the measurement of emission frequency above 1GHz if tested.
4. The test was performed in ADT Open Site No. 5.
5. The VCCI Site Registration No. is R-1039.



4.2.3 TEST PROCEDURES

- a. The EUT was placed on the top of a rotating table 0.8 meters above the ground at a 10 meter open area test site. The table was rotated 360 degrees to determine the position of the highest radiation.
- b. The EUT was set 3 meters away from the interference-receiving antenna, which was mounted on the top of a variable-height antenna tower.
- c. The antenna is a broadband antenna, and its height is varied from one meter to four meters above the ground to determine the maximum value of the field strength. Both horizontal and vertical polarizations of the antenna are set to make the measurement.
- d. For each suspected emission, the EUT was arranged to its worst case and then the antenna was tuned to heights from 1 meter to 4 meters and the rotatable table was turned from 0 degrees to 360 degrees to find the maximum reading.
- e. The test-receiver system was set to Peak Detect Function and Specified Bandwidth with Maximum Hold Mode.
- f. If the emission level of the EUT in peak mode was 10 dB lower than the limit specified, then testing could be stopped and the peak values of the EUT would be reported. Otherwise the emissions that did not have 10 dB margin would be re-tested one by one using peak, quasi-peak or average method as specified and then reported in a data sheet.

NOTE:

1. The resolution bandwidth and video bandwidth of test receiver/spectrum analyzer is 120kHz for Peak detection (PK) and Quasi-peak detection (QP) at frequency below 1GHz.
2. The resolution bandwidth and video bandwidth of test receiver/spectrum analyzer is 1 MHz for Peak detection at frequency above 1GHz.
3. The resolution bandwidth of test receiver/spectrum analyzer is 1 MHz and the video bandwidth is 10 Hz for Average detection (AV) at frequency above 1GHz.

4.2.4 DEVIATION FROM TEST STANDARD

No deviation

4.2.5 TEST SETUP

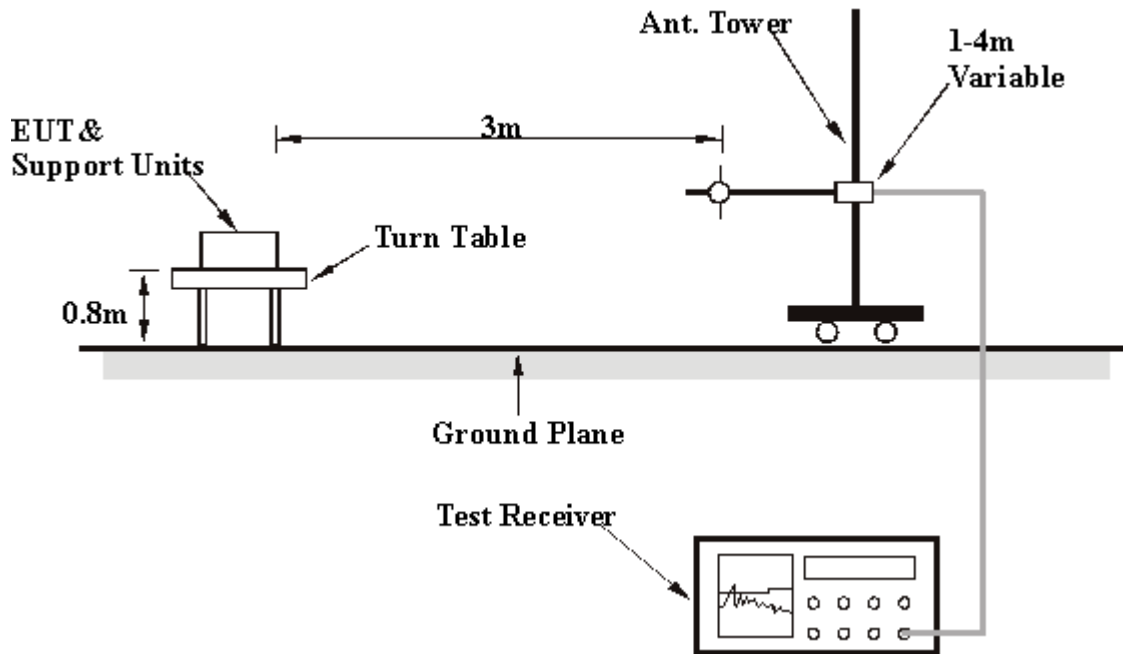

For the actual test configuration, please refer to the related item – Photographs of the Test Configuration.

4.2.6 EUT OPERATING CONDITIONS

Same as 4.1.6



4.2.7 TEST RESULTS

EUT	802.11g 54Mbps Wireless LAN Card	MODEL	WL 01 2454 NM1
MODE	Channel 11	FREQUENCY RANGE	Below 1000 MHz
INPUT POWER (SYSTEM)	120Vac, 60Hz	DETECTOR FUNCTION	Quasi-Peak
ENVIRONMENTAL CONDITIONS	20deg. C, 70%RH, 991hPa	TESTED BY: Vincent Lin	

ANTENNA POLARITY & TEST DISTANCE: HORIZONTAL AT 3 M								
No.	Freq. (MHz)	Emission Level (dBuV/m)	Limit (dBuV/m)	Margin (dB)	Antenna Height (m)	Table Angle (Degree)	Raw Value (dBuV)	Correction Factor (dB/m)
1	200.91	40.3 QP	43.50	-3.22	1.38 H	86	29.91	10.37
2	239.95	37.1 QP	46.00	-8.91	1.26 H	121	24.34	12.75
3	364.32	39.3 QP	46.00	-6.75	1.00 H	174	22.49	16.76
4	385.73	40.5 QP	46.00	-5.49	1.00 H	190	22.96	17.55
5	407.11	38.5 QP	46.00	-7.55	1.16 H	185	20.31	18.14
6	601.50	37.1 QP	46.00	-8.87	1.50 H	256	15.36	21.77
7	648.16	36.2 QP	46.00	-9.82	3.00 H	208	14.18	22.00

- REMARKS:**
1. Emission level(dBuV/m)=Raw Value(dBuV) + Correction Factor(dB)
 2. Correction Factor(dB/m) = Antenna Factor (dB/m) + Cable Factor (dB)
 3. The other emission levels were very low against the limit.
 4. Margin value = Emission level – Limit value.



EUT	802.11g 54Mbps Wireless LAN Card	MODEL	WL 01 2454 NM1
MODE	Channel 11	FREQUENCY RANGE	Below 1000 MHz
INPUT POWER (SYSTEM)	120Vac, 60Hz	DETECTOR FUNCTION	Quasi-Peak
ENVIRONMENTAL CONDITIONS	20deg. C, 70%RH, 991hPa	TESTED BY: Vincent Lin	

ANTENNA POLARITY & TEST DISTANCE: VERTICAL AT 3 M								
No.	Freq. (MHz)	Emission Level (dBuV/m)	Limit (dBuV/m)	Margin (dB)	Antenna Height (m)	Table Angle (Degree)	Raw Value (dBuV)	Correction Factor (dB/m)
1	74.71	30.4 QP	40.00	-9.63	1.00 V	229	23.28	7.09
2	199.12	36.5 QP	43.50	-7.00	1.00 V	124	26.20	10.30
3	239.94	36.4 QP	46.00	-9.65	2.00 V	13	23.60	12.75
4	401.28	33.3 QP	46.00	-12.66	1.00 V	163	15.25	18.09
5	648.16	34.7 QP	46.00	-11.33	1.75 V	103	12.67	22.00
6	801.72	39.7 QP	46.00	-6.32	1.25 V	259	16.33	23.35

- REMARKS:**
1. Emission level(dBuV/m)=Raw Value(dBuV) + Correction Factor(dB)
 2. Correction Factor(dB/m) = Antenna Factor (dB/m) + Cable Factor (dB)
 3. The other emission levels were very low against the limit.
 4. Margin value = Emission level – Limit value.



4.2.8 TEST RESULTS (A)

EUT	802.11g 54Mbps Wireless LAN Card	MODEL	WL 01 2454 NM1
MODE	Channel 1	FREQUENCY RANGE	1~25 GHz
INPUT POWER (SYSTEM)	120Vac, 60Hz	DETECTOR FUNCTION	Peak (PK) Average (AV)
ENVIRONMENTAL CONDITIONS	20deg. C, 70%RH, 991hPa	TESTED BY: Vincent Lin	

ANTENNA POLARITY & TEST DISTANCE: HORIZONTAL AT 3 M								
No.	Freq. (MHz)	Emission Level (dBuV/m)	Limit (dBuV/m)	Margin (dB)	Antenna Height (m)	Table Angle (Degree)	Raw Value (dBuV)	Correction Factor (dB/m)
1	2320.00	55.9 PK	74.00	-18.08	1.19 H	273	25.97	29.95
1	2320.00	49.7 AV	54.00	-4.26	1.19 H	273	19.79	29.95
2	2390.00	54.7 PK	74.00	-19.31	1.15 H	273	24.37	30.32
2	2390.00	46.4 AV	54.00	-7.65	1.15 H	273	16.03	30.32
3	*2412.00	113.1 PK			1.15 H	273	82.69	30.41
3	*2412.00	104.78 AV			1.15 H	273	74.37	30.41
4	2580.00	52.7 PK	74.00	-21.33	1.25 H	278	21.96	30.71
4	2580.00	47.8 AV	54.00	-6.25	1.25 H	278	17.04	30.71
5	4824.00	51.3 PK	74.00	-22.67	1.73 H	202	15.83	35.50
5	4824.00	38.2 AV	54.00	-15.83	1.73 H	202	2.67	35.50
6	9648.00	53.9 PK	74.00	-20.12	1.25 H	217	8.56	45.32
6	9648.00	41.9 AV	54.00	-12.11	1.25 H	217	-3.43	45.32

ANTENNA POLARITY & TEST DISTANCE: VERTICAL AT 3 M								
No.	Freq. (MHz)	Emission Level (dBuV/m)	Limit (dBuV/m)	Margin (dB)	Antenna Height (m)	Table Angle (Degree)	Raw Value (dBuV)	Correction Factor (dB/m)
1	2320.00	53.5 PK	74.00	-20.50	1.00 V	102	23.55	29.95
1	2320.00	45.3 AV	54.00	-8.71	1.00 V	102	15.34	29.95
2	2390.00	48.8 PK	74.00	-25.24	1.00 V	102	18.44	30.32
3	*2412.00	108.2 PK			1.00 V	102	77.78	30.41
3	*2412.00	99.9 AV			1.00 V	102	69.52	30.41
4	2580.00	58.0 PK	74.00	-16.05	1.00 V	103	27.24	30.71
4	2580.00	49.9 AV	54.00	-4.06	1.00 V	103	19.23	30.71
5	4824.00	50.0 PK	74.00	-24.05	1.57 V	221	14.45	35.50
6	9648.00	54.1 PK	74.00	-19.93	1.00 V	67	8.75	45.32
6	9648.00	41.4 AV	54.00	-12.64	1.00 V	67	-3.96	45.32

REMARKS:

1. Emission level(dBuV/m)=Raw Value(dBuV) + Correction Factor(dB)
2. Correction Factor(dB/m) = Antenna Factor (dB/m) + Cable Factor (dB)
3. The other emission levels were very low against the limit.
4. Margin value = Emission level – Limit value.
5. “ * “ : Fundamental frequency



EUT	802.11g 54Mbps Wireless LAN Card	MODEL	WL 01 2454 NM1
MODE	Channel 6	FREQUENCY RANGE	1~25 GHz
INPUT POWER (SYSTEM)	120Vac, 60Hz	DETECTOR FUNCTION	Peak(PK) Average (AV)
ENVIRONMENTAL CONDITIONS	20deg. C, 70%RH, 991hPa	TESTED BY: Vincent Lin	

ANTENNA POLARITY & TEST DISTANCE: HORIZONTAL AT 3 M								
No.	Freq. (MHz)	Emission Level (dBuV/m)	Limit (dBuV/m)	Margin (dB)	Antenna Height (m)	Table Angle (Degree)	Raw Value (dBuV)	Correction Factor (dB/m)
1	*2437.00	111.1 PK			1.36 H	276	80.57	30.50
1	*2437.00	103.2 AV			1.36 H	276	72.68	30.50
2	4874.00	59.3 PK	74.00	-14.67	2.11 H	189	23.57	35.76
2	4874.00	46.7 AV	54.00	-7.30	2.11 H	189	10.94	35.76
3	7311.00	58.6 PK	74.00	-15.36	1.43 H	220	17.40	41.24
3	7311.00	46.7 AV	54.00	-7.33	1.43 H	220	5.43	41.24
4	9748.00	57.3 PK	74.00	-16.74	1.96 H	208	12.23	45.04
4	9748.00	41.8 AV	54.00	-12.18	1.96 H	208	-3.21	45.04

ANTENNA POLARITY & TEST DISTANCE: VERTICAL AT 3 M								
No.	Freq. (MHz)	Emission Level (dBuV/m)	Limit (dBuV/m)	Margin (dB)	Antenna Height (m)	Table Angle (Degree)	Raw Value (dBuV)	Correction Factor (dB/m)
1	*2437.00	104.7 PK			1.26 V	113	74.21	30.50
1	*2437.00	96.5 AV			1.26 V	113	65.95	30.50
2	4874.00	59.6 PK	74.00	-14.37	1.00 V	207	23.87	35.76
2	4874.00	48.4 AV	54.00	-5.56	1.00 V	207	12.68	35.76
3	7311.00	56.3 PK	74.00	-17.72	1.23 V	183	15.04	41.24
3	7311.00	44.4 AV	54.00	-9.59	1.23 V	183	3.17	41.24
4	9748.00	53.2 PK	74.00	-20.77	1.98 V	247	8.20	45.04
4	9748.00	41.7 AV	54.00	-12.31	1.98 V	247	-3.34	45.04

REMARKS:

1. Emission level(dBuV/m)=Raw Value(dBuV) + Correction Factor(dB)
2. Correction Factor(dB/m) = Antenna Factor (dB/m) + Cable Factor (dB)
3. The other emission levels were very low against the limit.
4. Margin value = Emission level – Limit value.
5. “ * “ : Fundamental frequency



EUT	802.11g 54Mbps Wireless LAN Card	MODEL	WL 01 2454 NM1
MODE	Channel 11	FREQUENCY RANGE	1~25 GHz
INPUT POWER (SYSTEM)	120Vac, 60Hz	DETECTOR FUNCTION	Peak(PK) Average (AV)
ENVIRONMENTAL CONDITIONS	20deg. C, 70%RH, 991hPa	TESTED BY: Vincent Lin	

ANTENNA POLARITY & TEST DISTANCE: HORIZONTAL AT 3 M

No.	Freq. (MHz)	Emission Level (dBuV/m)	Limit (dBuV/m)	Margin (dB)	Antenna Height (m)	Table Angle (Degree)	Raw Value (dBuV)	Correction Factor (dB/m)
1	2408.00	62.7 PK	92.33	-29.63	1.01 H	248	32.34	30.40
1	2408.00	54.5 AV	84.11	-29.61	1.01 H	248	24.12	30.40
2	*2462.00	112.3 PK			1.01 H	248	81.74	30.59
2	*2462.00	104.1 AV			1.01 H	248	73.52	30.59
3	2483.50	49.5 PK	74.00	-24.46	1.01 H	248	18.87	30.67
3	2483.50	41.32 AV	54.00	-12.68	1.01 H	248	10.65	30.67
4	2488.00	58.9 PK	74.00	-15.13	1.01 H	248	28.18	30.69
4	2488.00	50.7 AV	54.00	-3.35	1.01 H	248	19.96	30.69
5	4924.00	52.4 PK	74.00	-21.65	1.98 H	204	16.37	35.99
5	4924.00	39.0 AV	54.00	-15.01	1.98 H	204	3.00	35.99
6	9848.00	53.5 PK	74.00	-20.53	1.99 H	291	8.54	44.93
6	9848.00	40.4 AV	54.00	-13.61	1.99 H	291	-4.54	44.93

ANTENNA POLARITY & TEST DISTANCE: VERTICAL AT 3 M

No.	Freq. (MHz)	Emission Level (dBuV/m)	Limit (dBuV/m)	Margin (dB)	Antenna Height (m)	Table Angle (Degree)	Raw Value (dBuV)	Correction Factor (dB/m)
1	2408.00	60.4 PK	74.00	-13.60	1.05 V	62	30.00	30.40
1	2408.00	52.2 AV	54.00	-1.81	1.05 V	62	21.79	30.40
2	*2462.00	110.0 PK			1.05 V	62	79.40	30.59
2	*2462.00	101.8 AV			1.05 V	62	71.19	30.59
3	2483.50	47.2 PK	74.00	-26.80	1.05 V	62	16.53	30.67
3	2483.50	38.99 AV	54.00	-15.01	1.05 V	62	8.32	30.67
4	2488.00	56.5 PK	74.00	-17.47	1.05 V	62	25.84	30.69
4	2488.00	48.3 AV	54.00	-5.68	1.05 V	62	17.63	30.69
5	4924.00	53.1 PK	74.00	-20.93	1.38 V	223	17.09	35.99
5	4924.00	40.6 AV	54.00	-13.37	1.38 V	223	4.65	35.99
6	7386.00	52.8 PK	74.00	-21.19	1.22 V	68	11.12	41.69
6	7386.00	40.1 AV	54.00	-13.86	1.22 V	68	-1.55	41.69
7	9848.00	56.5 PK	74.00	-17.51	1.72 V	243	11.56	44.93
7	9848.00	46.4 AV	54.00	-7.65	1.72 V	243	1.42	44.93

REMARKS:

1. Emission level(dBuV/m)=Raw Value(dBuV) + Correction Factor(dB)
2. Correction Factor(dB/m) = Antenna Factor (dB/m) + Cable Factor (dB)
3. The other emission levels were very low against the limit.
4. Margin value = Emission level – Limit value.
5. “ * “ : Fundamental frequency



4.2.9 TEST RESULTS (B)

EUT	802.11g 54Mbps Wireless LAN Card	MODEL	WL 01 2454 NM1
MODE	Channel 1	FREQUENCY RANGE	1~25 GHz
INPUT POWER (SYSTEM)	120Vac, 60Hz	DETECTOR FUNCTION	Peak(PK) Average (AV)
ENVIRONMENTAL CONDITIONS	20deg. C, 70%RH, 991hPa	TESTED BY: Vincent Lin	

ANTENNA POLARITY & TEST DISTANCE: HORIZONTAL AT 3 M								
No.	Freq. (MHz)	Emission Level (dBuV/m)	Limit (dBuV/m)	Margin (dB)	Antenna Height (m)	Table Angle (Degree)	Raw Value (dBuV)	Correction Factor (dB/m)
1	2320.00	61.7 PK	74.00	-12.34	1.15 H	275	31.71	29.95
1	2320.00	52.2 AV	54.00	-1.83	1.15 H	275	22.22	29.95
2	2390.00	56.5 PK	74.00	-17.48	1.15 H	275	26.20	30.32
2	2390.00	47.0 AV	54.00	-6.97	1.15 H	275	16.71	30.32
3	*2412.00	107.2 PK			1.15 H	275	76.81	30.41
3	*2412.00	97.7 AV			1.15 H	275	67.32	30.41
4	2580.00	64.6 PK	87.20	-22.60	1.15 H	275	33.86	30.71
4	2580.00	55.08 AV	77.70	-22.62	1.15 H	275	24.37	30.71
5	4824.00	47.4 PK	74.00	-26.60	2.30 H	179	11.90	35.50
5	4824.00	34.00 AV	54.00	-20.03	2.30 H	179	-1.53	35.50

ANTENNA POLARITY & TEST DISTANCE: VERTICAL AT 3 M								
No.	Freq. (MHz)	Emission Level (dBuV/m)	Limit (dBuV/m)	Margin (dB)	Antenna Height (m)	Table Angle (Degree)	Raw Value (dBuV)	Correction Factor (dB/m)
1	2320.00	55.2 PK	74.00	-18.85	1.00 V	101	25.20	29.95
1	2320.00	45.6 AV	54.00	-8.42	1.00 V	101	15.63	29.95
2	2390.00	50.0 PK	74.00	-23.99	1.00 V	101	19.69	30.32
2	2390.00	10.12 AV	54.00	-13.56	1.00 V	101	10.12	30.32
3	*2412.00	100.7 PK			1.00 V	101	70.30	30.41
3	*2412.00	91.1 AV			1.00 V	101	60.73	30.41
4	2580.00	58.1 PK	74.00	-15.91	1.00 V	101	27.38	30.71
4	2580.00	48.5 AV	54.00	-5.51	1.00 V	101	17.78	30.71
5	4824.00	46.5 PK	74.00	-27.54	1.76 V	304	10.96	35.50
5	4824.00	33.3 AV	54.00	-20.74	1.76 V	304	-2.24	35.50

REMARKS:

1. Emission level(dBuV/m)=Raw Value(dBuV) + Correction Factor(dB)
2. Correction Factor(dB/m) = Antenna Factor (dB/m) + Cable Factor (dB)
3. The other emission levels were very low against the limit.
4. Margin value = Emission level – Limit value.
5. “ * “ : Fundamental frequency



EUT	802.11g 54Mbps Wireless LAN Card	MODEL	WL 01 2454 NM1
MODE	Channel 6	FREQUENCY RANGE	1~25 GHz
INPUT POWER (SYSTEM)	120Vac, 60Hz	DETECTOR FUNCTION	Peak(PK) Average (AV)
ENVIRONMENTAL CONDITIONS	20deg. C, 70%RH, 991hPa	TESTED BY: Vincent Lin	

ANTENNA POLARITY & TEST DISTANCE: HORIZONTAL AT 3 M								
No.	Freq. (MHz)	Emission Level (dBuV/m)	Limit (dBuV/m)	Margin (dB)	Antenna Height (m)	Table Angle (Degree)	Raw Value (dBuV)	Correction Factor (dB/m)
1	2343.00	60.6 PK	74.00	-13.36	1.13 H	276	30.57	30.07
1	2343.00	51.2 AV	54.00	-2.76	1.13 H	276	21.17	30.07
2	2383.00	61.7 PK	74.00	-12.31	1.13 H	276	31.41	30.28
2	2383.00	52.3 AV	54.00	-1.71	1.13 H	276	22.01	30.28
3	*2437.00	109.6 PK			1.13 H	276	79.06	30.50
3	*2437.00	100.2 AV			1.13 H	276	69.66	30.50
4	2574.00	55.5 PK	74.00	-18.51	1.28 H	272	24.78	30.72
4	2574.00	44.9 AV	54.00	-9.15	1.28 H	272	14.14	30.72
5	4874.00	57.9 PK	74.00	-16.06	1.29 H	177	22.18	35.76
5	4874.00	43.9 AV	54.00	-10.06	1.29 H	177	8.18	35.76
6	7311.00	58.7 PK	74.00	-15.31	1.43 H	181	17.45	41.24
6	7311.00	44.5 AV	54.00	-9.48	1.43 H	181	3.28	41.24

ANTENNA POLARITY & TEST DISTANCE: VERTICAL AT 3 M								
No.	Freq. (MHz)	Emission Level (dBuV/m)	Limit (dBuV/m)	Margin (dB)	Antenna Height (m)	Table Angle (Degree)	Raw Value (dBuV)	Correction Factor (dB/m)
1	2343.00	53.0 PK	74.00	-21.00	1.05 V	84	22.93	30.07
1	2343.00	43.7 AV	54.00	-10.31	1.05 V	84	13.62	30.07
2	2383.00	54.1 PK	74.00	-19.95	1.05 V	84	23.77	30.28
2	2383.00	44.7 AV	54.00	-9.26	1.05 V	84	14.46	30.28
3	*2437.00	101.9 PK			1.05 V	84	71.42	30.50
3	*2437.00	92.6 AV			1.05 V	84	62.11	30.50
4	2574.00	47.0 PK	74.00	-27.03	1.00 V	86	16.26	30.72
4	2574.00	36.7 AV	54.00	-17.26	1.00 V	86	6.03	30.72
5	4874.00	57.6 PK	74.00	-16.37	1.00 V	206	21.87	35.76
5	4874.00	43.6 AV	54.00	-10.44	1.00 V	206	7.80	35.76
6	7311.00	56.9 PK	74.00	-17.06	1.12 V	183	15.70	41.24
6	7311.00	42.5 AV	54.00	-11.49	1.12 V	183	1.27	41.24

REMARKS:

1. Emission level(dBuV/m)=Raw Value(dBuV) + Correction Factor(dB)
2. Correction Factor(dB/m) = Antenna Factor (dB/m) + Cable Factor (dB)
3. The other emission levels were very low against the limit.
4. Margin value = Emission level – Limit value.
5. “ * “ : Fundamental frequency



EUT	802.11g 54Mbps Wireless LAN Card	MODEL	WL 01 2454 NM1
MODE	Channel 11	FREQUENCY RANGE	1~25 GHz
INPUT POWER (SYSTEM)	120Vac, 60Hz	DETECTOR FUNCTION	Peak(PK) Average (AV)
ENVIRONMENTAL CONDITIONS	20deg. C, 70%RH, 991hPa	TESTED BY: Vincent Lin	

ANTENNA POLARITY & TEST DISTANCE: HORIZONTAL AT 3 M								
No.	Freq. (MHz)	Emission Level (dBuV/m)	Limit (dBuV/m)	Margin (dB)	Antenna Height (m)	Table Angle (Degree)	Raw Value (dBuV)	Correction Factor (dB/m)
1	*2462.00	106.2 PK			1.17 H	276	75.57	30.59
1	*2462.00	96.8 AV			1.17 H	276	66.22	30.59
2	2483.50	51.8 PK	74.00	-22.25	1.17 H	276	21.08	30.67
2	2483.50	42.4 AV	54.00	-11.60	1.17 H	276	11.73	30.67
3	2488.00	62.1 PK	74.00	-11.86	1.17 H	276	31.45	30.69
3	2488.00	52.8 AV	54.00	-1.21	1.17 H	276	22.10	30.69
4	2573.00	49.9 PK	74.00	-24.11	1.00 H	309	19.17	30.72
4	2573.00	40.6 AV	54.00	-13.45	1.00 H	309	9.83	30.72
5	4924.00	47.6 PK	74.00	-26.45	1.89 H	173	11.57	35.99
5	4924.00	34.2 AV	54.00	-19.81	1.89 H	173	-1.79	35.99

ANTENNA POLARITY & TEST DISTANCE: VERTICAL AT 3 M								
No.	Freq. (MHz)	Emission Level (dBuV/m)	Limit (dBuV/m)	Margin (dB)	Antenna Height (m)	Table Angle (Degree)	Raw Value (dBuV)	Correction Factor (dB/m)
1	*2462.00	99.0 PK			1.00 V	96	68.44	30.59
1	*2462.00	89.6 AV			1.00 V	96	59.05	30.59
2	2483.50	44.6 PK	74.00	-29.38	1.00 V	96	13.95	30.67
3	2488.00	55.0 PK	74.00	-18.99	1.00 V	96	24.32	30.69
3	2488.00	45.6 AV	54.00	-8.38	1.00 V	96	14.93	30.69
4	2573.00	50.2 PK	74.00	-23.85	1.00 V	90	19.44	30.72
4	2573.33	39.8 AV	54.00	-14.16	1.00 V	90	9.13	30.72
5	4924.00	47.2 PK	74.00	-26.80	1.00 V	218	11.22	35.99
5	4924.00	33.6 AV	54.00	-20.40	1.00 V	218	-2.38	35.99

REMARKS:

1. Emission level(dBuV/m)=Raw Value(dBuV) + Correction Factor(dB)
2. Correction Factor(dB/m) = Antenna Factor (dB/m) + Cable Factor (dB)
3. The other emission levels were very low against the limit.
4. Margin value = Emission level – Limit value.
5. “ * “ : Fundamental frequency



4.3 6dB BANDWIDTH MEASUREMENT

4.3.1 LIMITS OF 6dB BANDWIDTH MEASUREMENT

The minimum of 6dB Bandwidth Measurement is 0.5MHz.

4.3.2 TEST INSTRUMENTS

Description & Manufacturer	Model No.	Serial No.	Calibrated Until
SPECTRUM ANALYZER	FSEK30	100049	Aug. 12, 2004

NOTE:

The calibration interval of the above test instruments is 12 months and the calibrations are traceable to NML/ROC and NIST/USA.

4.3.3 TEST PROCEDURE

The transmitter output was connected to the spectrum analyzer through an attenuator. The bandwidth of the fundamental frequency was measured by spectrum analyzer with 100kHz RBW and 100kHz VBW. The 6dB bandwidth is defined as the total spectrum the power of which is higher than peak power minus 6dB.

4.3.4 DEVIATION FROM TEST STANDARD

No deviation

4.3.5 TEST SETUP

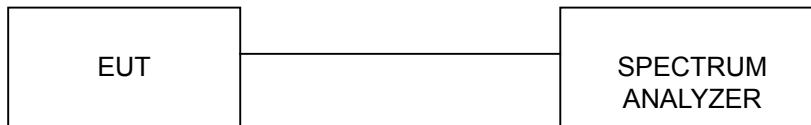

For the actual test configuration, please refer to the related Item – Photographs of the Test Configuration.

4.3.6 EUT OPERATING CONDITIONS

The software provided by client to enable the EUT under transmission condition continuously at lowest, middle and highest channel frequencies individually.



4.3.7 TEST RESULTS (A)

EUT	802.11g 54Mbps Wireless LAN Card	MODEL	WL 01 2454 NM1
INPUT POWER (SYSTEM)	120Vac, 60Hz	ENVIRONMENTAL CONDITIONS	20deg. C, 62%RH, 991hPa
TESTED BY: Stanely Hsu			

CHANNEL	CHANNEL FREQUENCY (MHz)	6dB BANDWIDTH (MHz)	MINIMUM LIMIT (MHz)	PASS/FAIL
1	2412	9.56	0.5	PASS
6	2437	9.48	0.5	PASS
11	2462	8.20	0.5	PASS



CH1

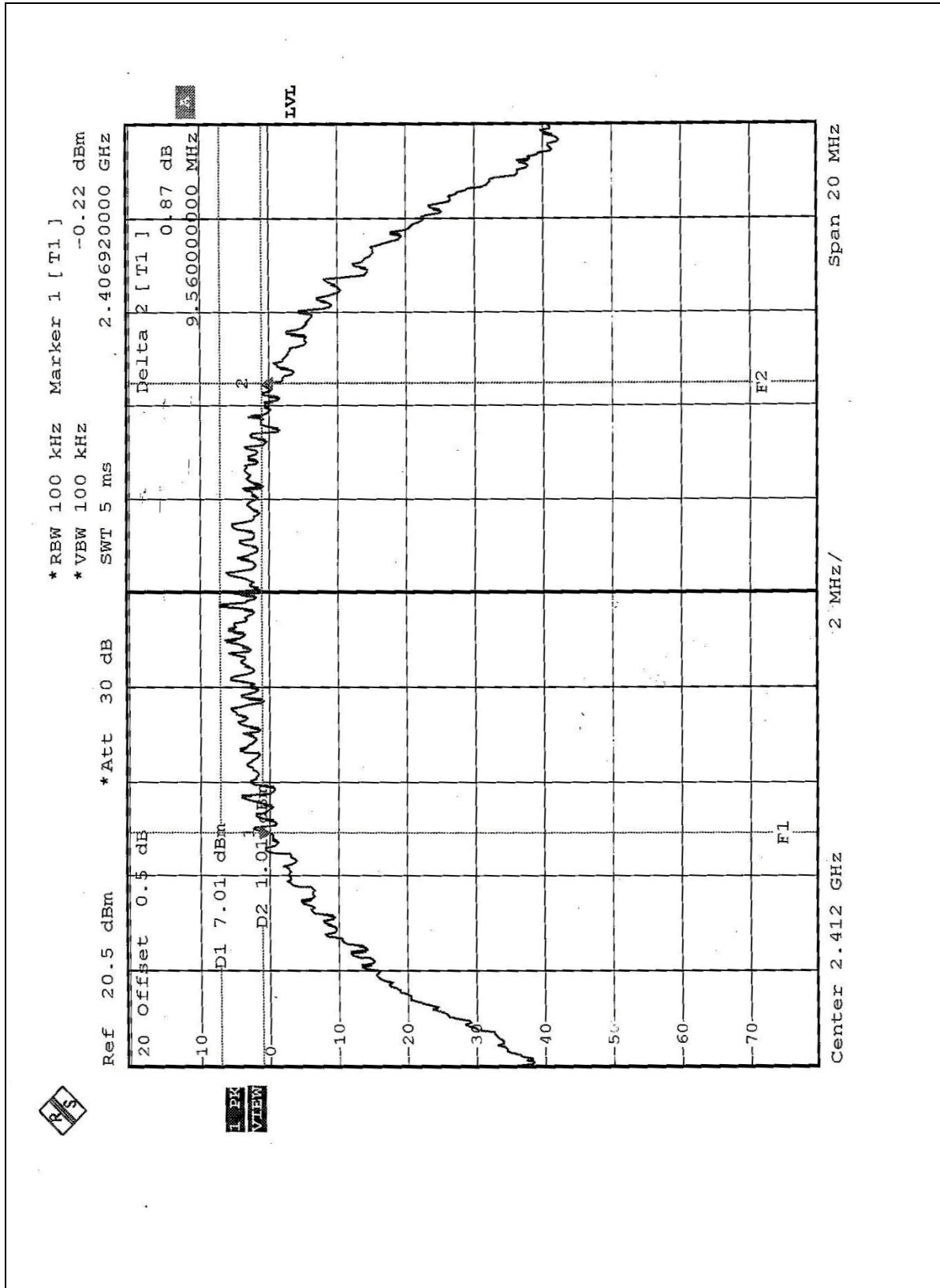



CH6

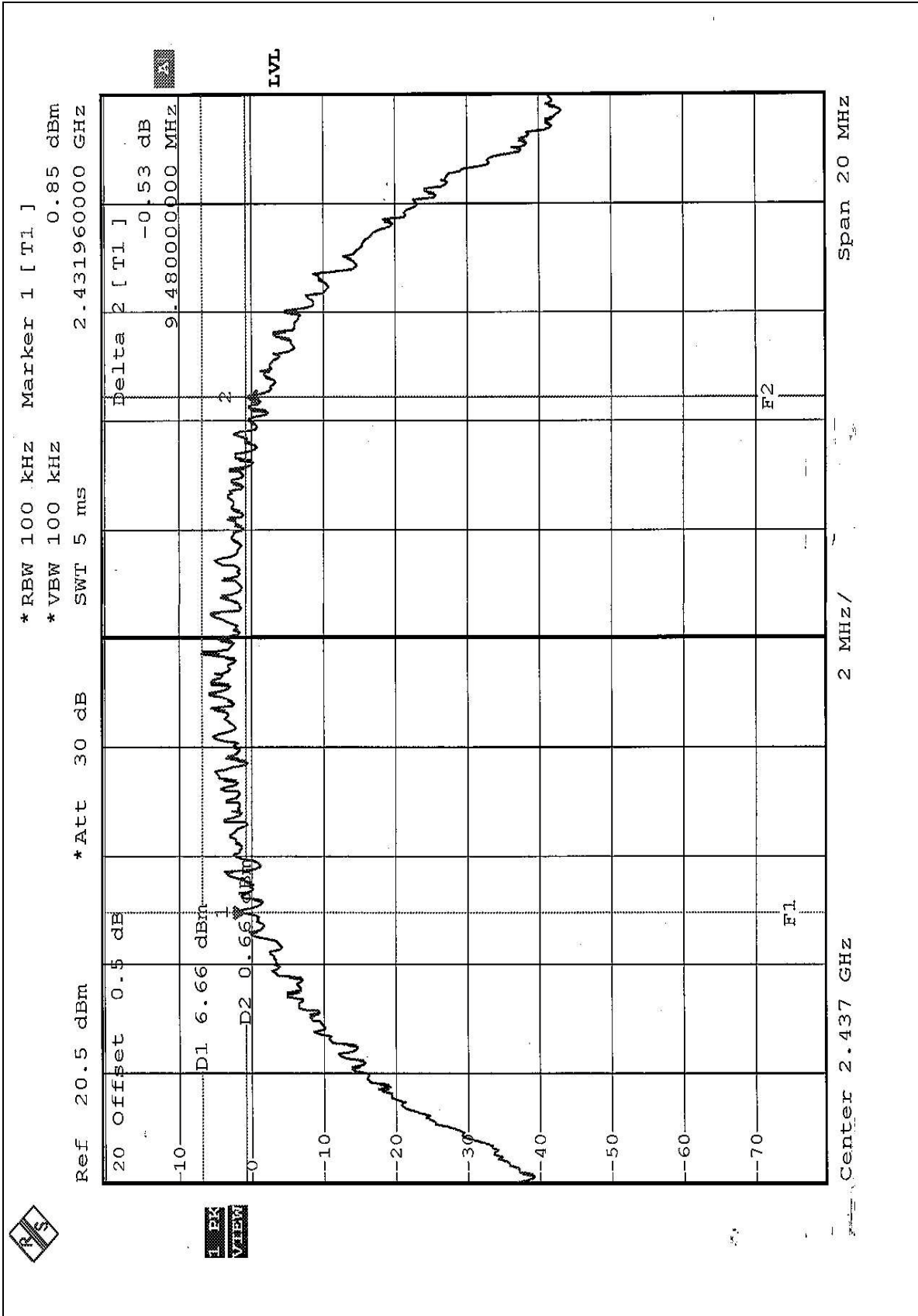



CH11

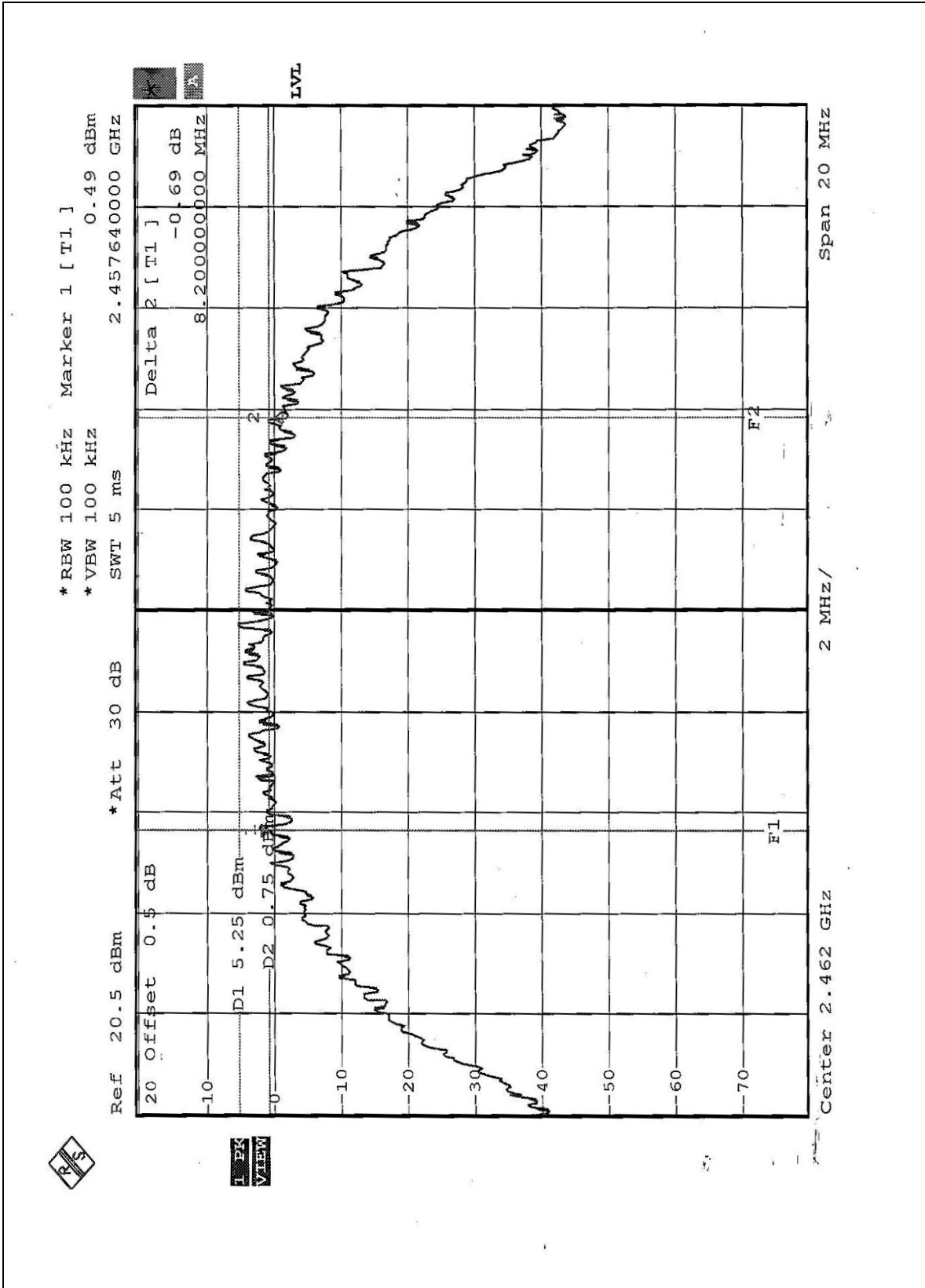



4.3.8 TEST RESULTS (B)

EUT	802.11g 54Mbps Wireless LAN Card	MODEL	WL 01 2454 NM1
INPUT POWER (SYSTEM)	120Vac, 60Hz	ENVIRONMENTAL CONDITIONS	20deg. C, 62%RH, 991hPa
TESTED BY: Stanely Hsu			

CHANNEL	CHANNEL FREQUENCY (MHz)	6 dB BANDWIDTH (MHz)	MINIMUM LIMIT (MHz)	PASS/FAIL
1	2412	16.08	0.5	PASS
6	2437	15.84	0.5	PASS
11	2462	15.84	0.5	PASS



CH1

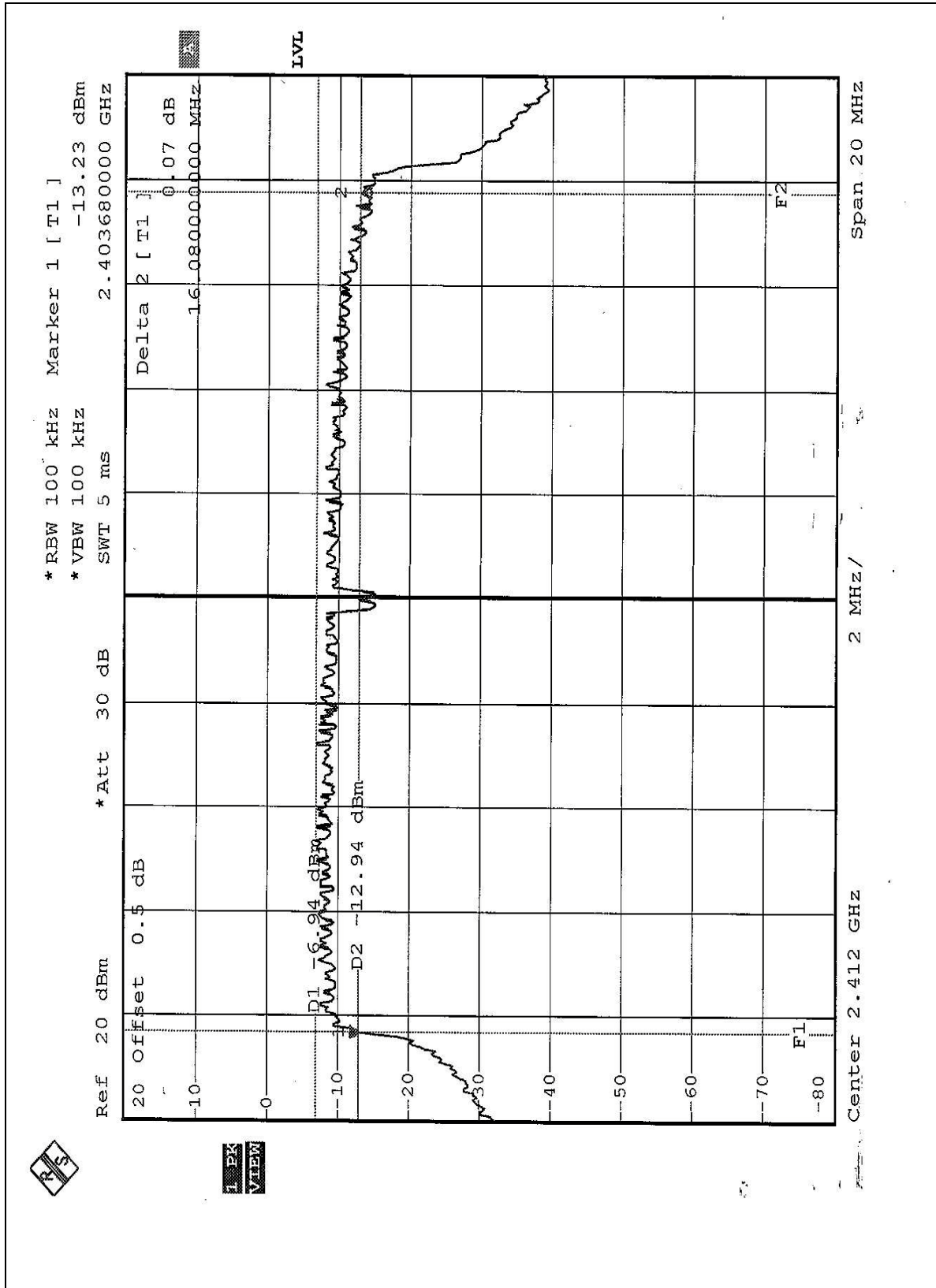



CH6

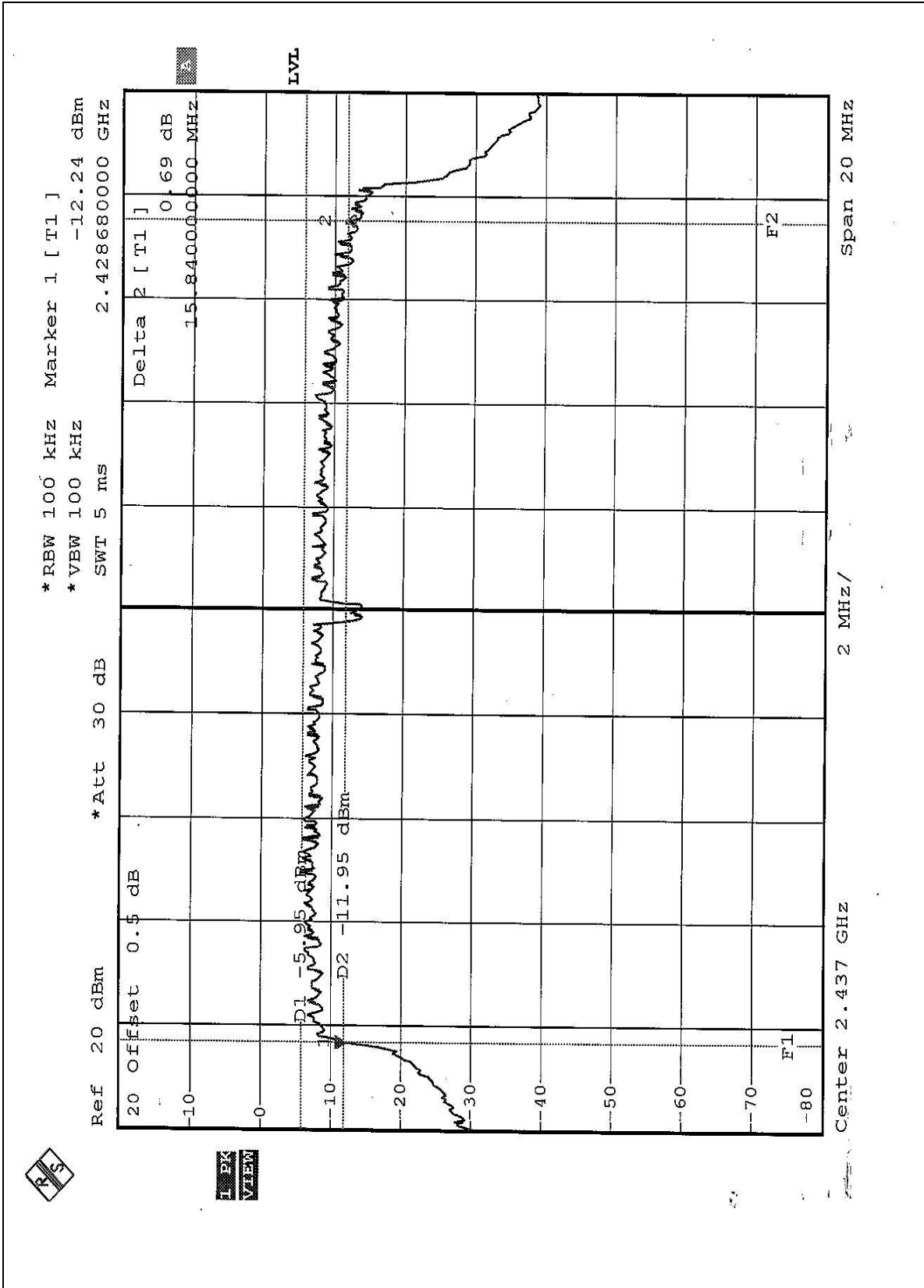



CH11

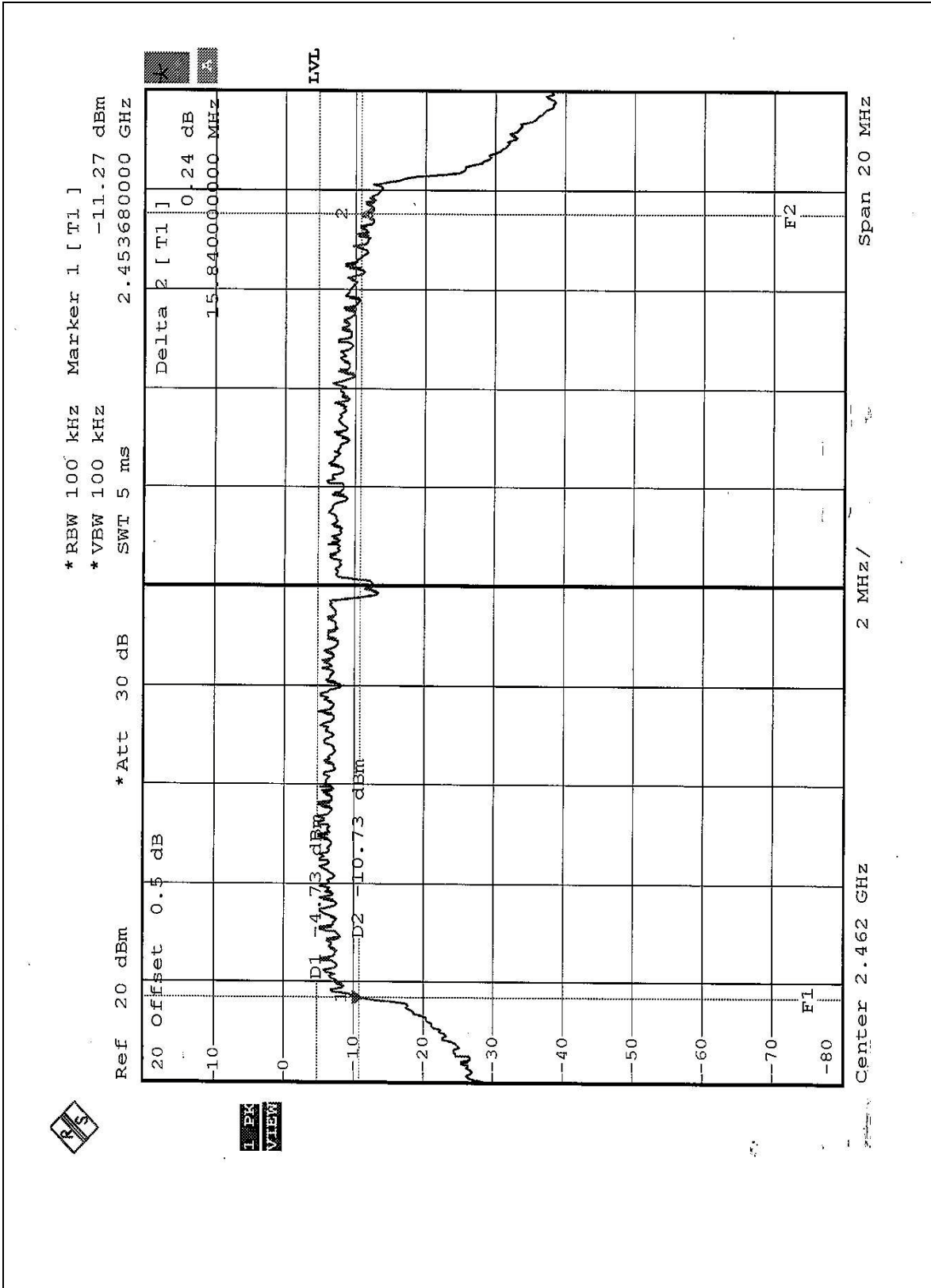



4.4 MAXIMUM PEAK OUTPUT POWER

4.4.1 LIMITS OF MAXIMUM PEAK OUTPUT POWER MEASUREMENT

The Maximum Peak Output Power Measurement is 30dBm.

4.4.2 TEST INSTRUMENTS

Description & Manufacturer	Model No.	Serial No.	Calibrated On
R&S SPECTRUM ANALYZER	FSEK30	100049	Aug. 12, 2004
R&S SIGNAL GENERATOR	SMP04	100011	May 28, 2004
TEKTRONIX OSCILLOSCOPE	TDS 220	B048470	Mar. 05, 2004
NARDA DETECTOR	4503A	FSCM99899	NA

NOTE:

The calibration interval of the above test instruments is 12 months and the calibrations are traceable to NML/ROC and NIST/USA.



4.4.3 TEST PROCEDURES

1. A detector was used on the output port of the EUT. An oscilloscope was used to read the response of the detector.
2. Replaced the EUT by the signal generator. The center frequency of the S.G. was adjusted to the center frequency of the measured channel.
3. Adjusted the power to have the same reading on oscilloscope. Record the power level.

4.4.4 DEVIATION FROM TEST STANDARD

No deviation

4.4.5 TEST SETUP

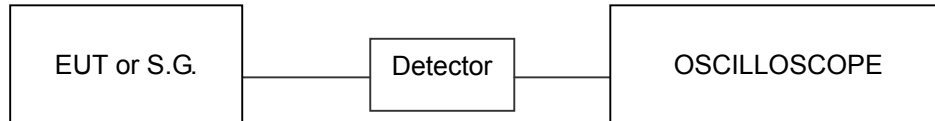

4.4.6 EUT OPERATING CONDITIONS

Same as Item 4.3.6



4.4.7 TEST RESULTS (A)

EUT	802.11g 54Mbps Wireless LAN Card	MODEL	WL 01 2454 NM1
INPUT POWER (SYSTEM)	120Vac, 60Hz	ENVIRONMENTAL CONDITIONS	20deg. C, 62%RH, 991hPa
TESTED BY: Stanely Hsu			

CHANNEL	CHANNEL FREQUENCY (MHz)	PEAK POWER OUTPUT (dBm)	PEAK POWER LIMIT (dBm)	PASS/FAIL
1	2412	17.39	30	PASS
6	2437	16.60	30	PASS
11	2462	16.61	30	PASS



4.4.8 TEST RESULTS (B)

EUT	802.11g 54Mbps Wireless LAN Card	MODEL	WL 01 2454 NM1
INPUT POWER (SYSTEM)	120Vac, 60Hz	ENVIRONMENTAL CONDITIONS	20deg. C, 62%RH, 991hPa
TESTED BY: Stanely Hsu			

CHANNEL	CHANNEL FREQUENCY (MHz)	PEAK POWER OUTPUT (dBm)	PEAK POWER LIMIT (dBm)	PASS/FAIL
1	2412	16.62	30	PASS
6	2437	16.64	30	PASS
11	2462	17.37	30	PASS



4.5 POWER SPECTRAL DENSITY MEASUREMENT

4.5.1 LIMITS OF POWER SPECTRAL DENSITY MEASUREMENT

The Maximum of Power Spectral Density Measurement is 8dBm.

4.5.2 TEST INSTRUMENTS

Description & Manufacturer	Model No.	Serial No.	Calibrated Until
SPECTRUM ANALYZER	FSEK30	100049	Aug. 12, 2004

NOTE:

The calibration interval of the above test instruments is 12 months and the calibrations are traceable to NML/ROC and NIST/USA.

4.5.3 TEST PROCEDURE

The transmitter output was connected to the spectrum analyzer through an attenuator, the bandwidth of the fundamental frequency was measured with the spectrum analyzer using 3 kHz RBW and 30 kHz VBW, set sweep time=span/3kHz. The power spectral density was measured and recorded. The sweep time is allowed to be longer than span/3KHz for a full response of the mixer in the spectrum analyzer.

4.5.4 DEVIATION FROM TEST STANDARD

No deviation

4.5.5 TEST SETUP

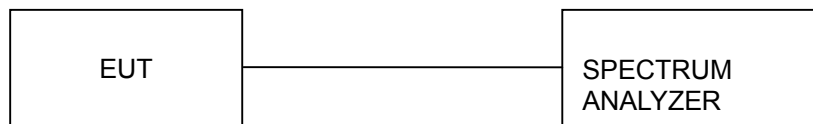

4.5.6 EUT OPERATING CONDITIONS

Same as 4.3.6



4.5.7 TEST RESULTS (A)

EUT	802.11g 54Mbps Wireless LAN Card	MODEL	WL 01 2454 NM1
INPUT POWER (SYSTEM)	120Vac, 60Hz	ENVIRONMENTAL CONDITIONS	20deg. C, 62%RH, 991hPa
TESTED BY: Stanely Hsu			

CHANNEL NUMBER	CHANNEL FREQUENCY (MHz)	RF POWER LEVEL IN 3KHz BW (dBm)	MAXIMUM LIMIT (dBm)	PASS/FAIL
1	2412	-8.62	8	PASS
6	2437	-9.06	8	PASS
11	2462	-10.26	8	PASS



CH1

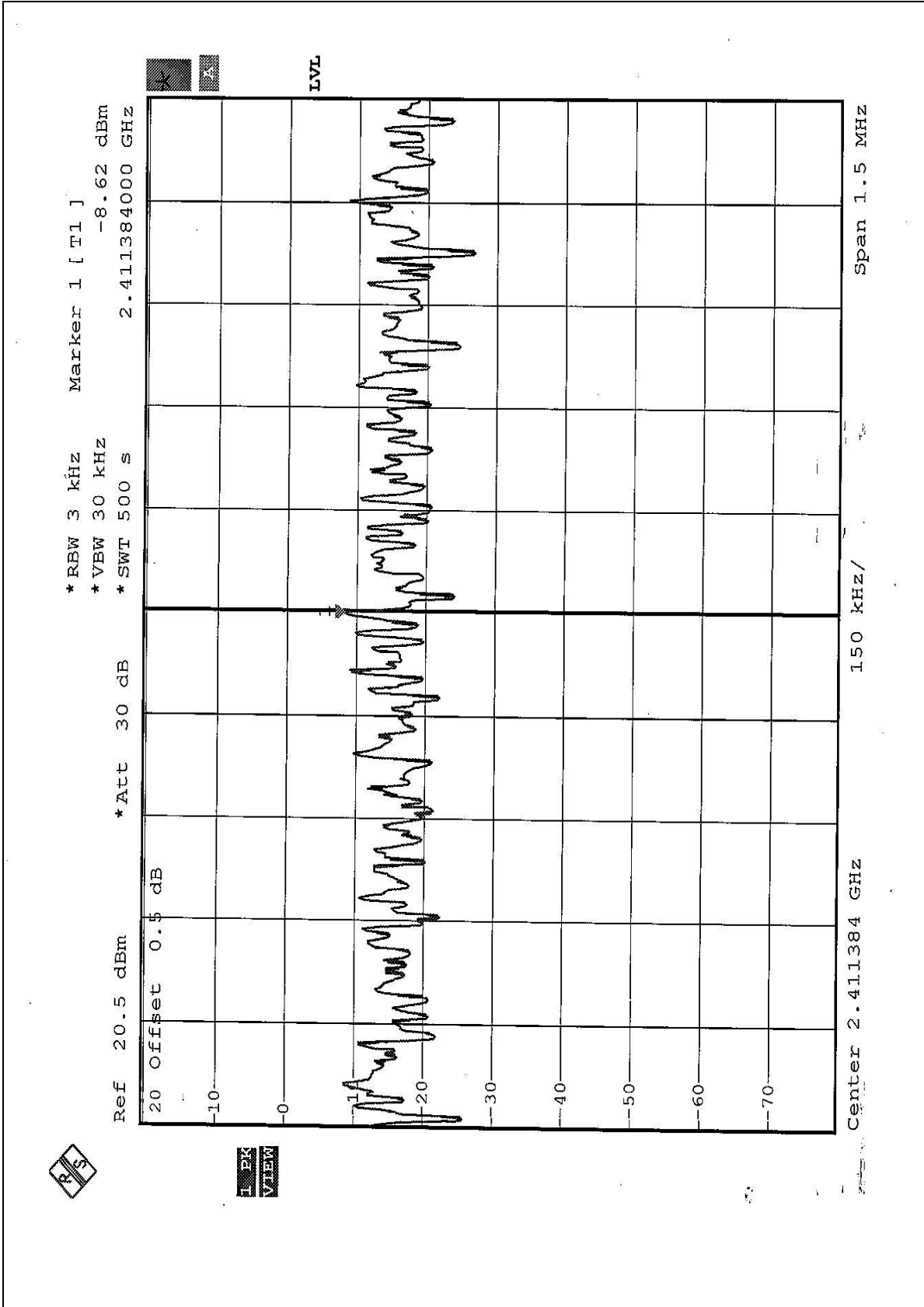



CH6

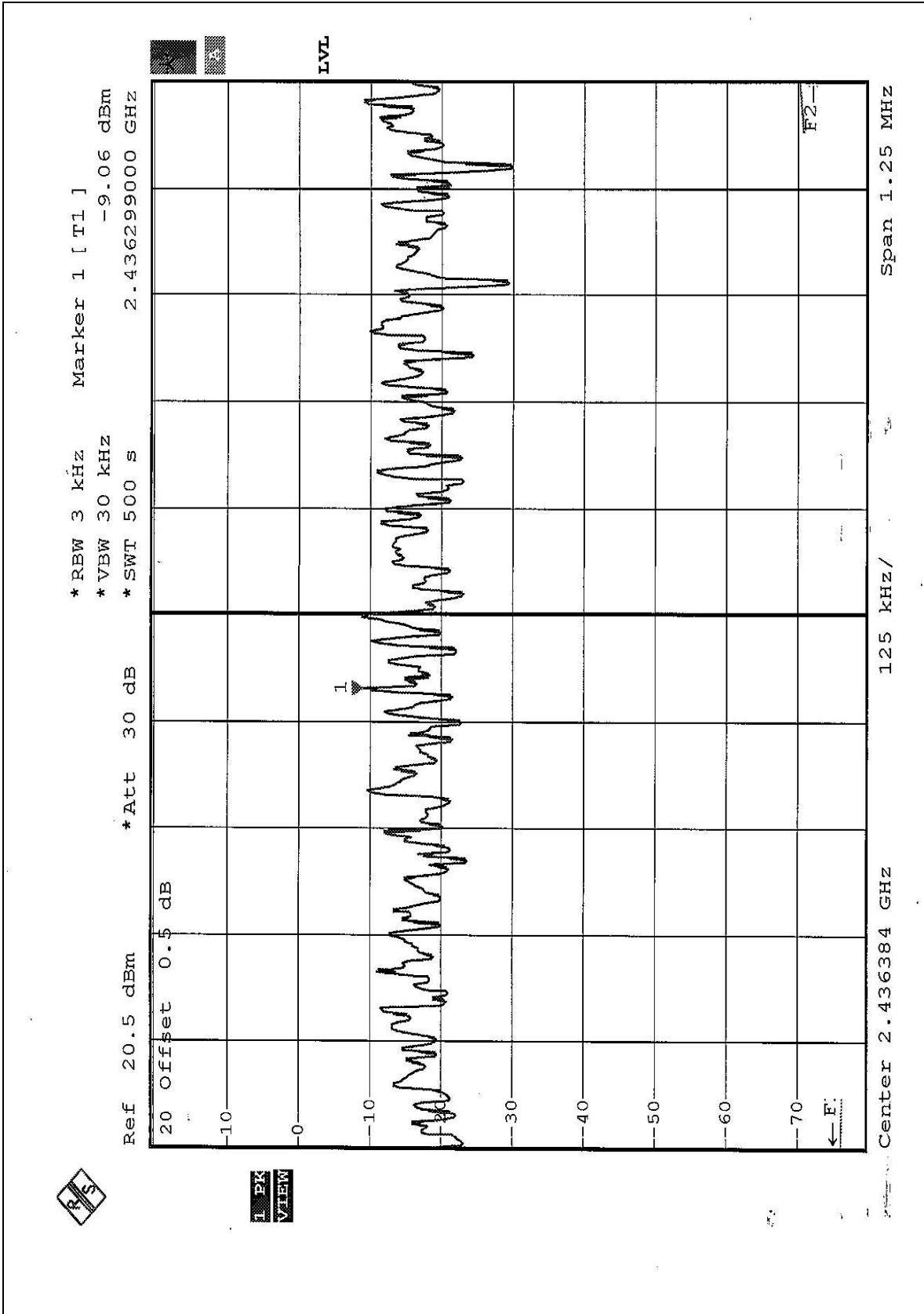



CH11

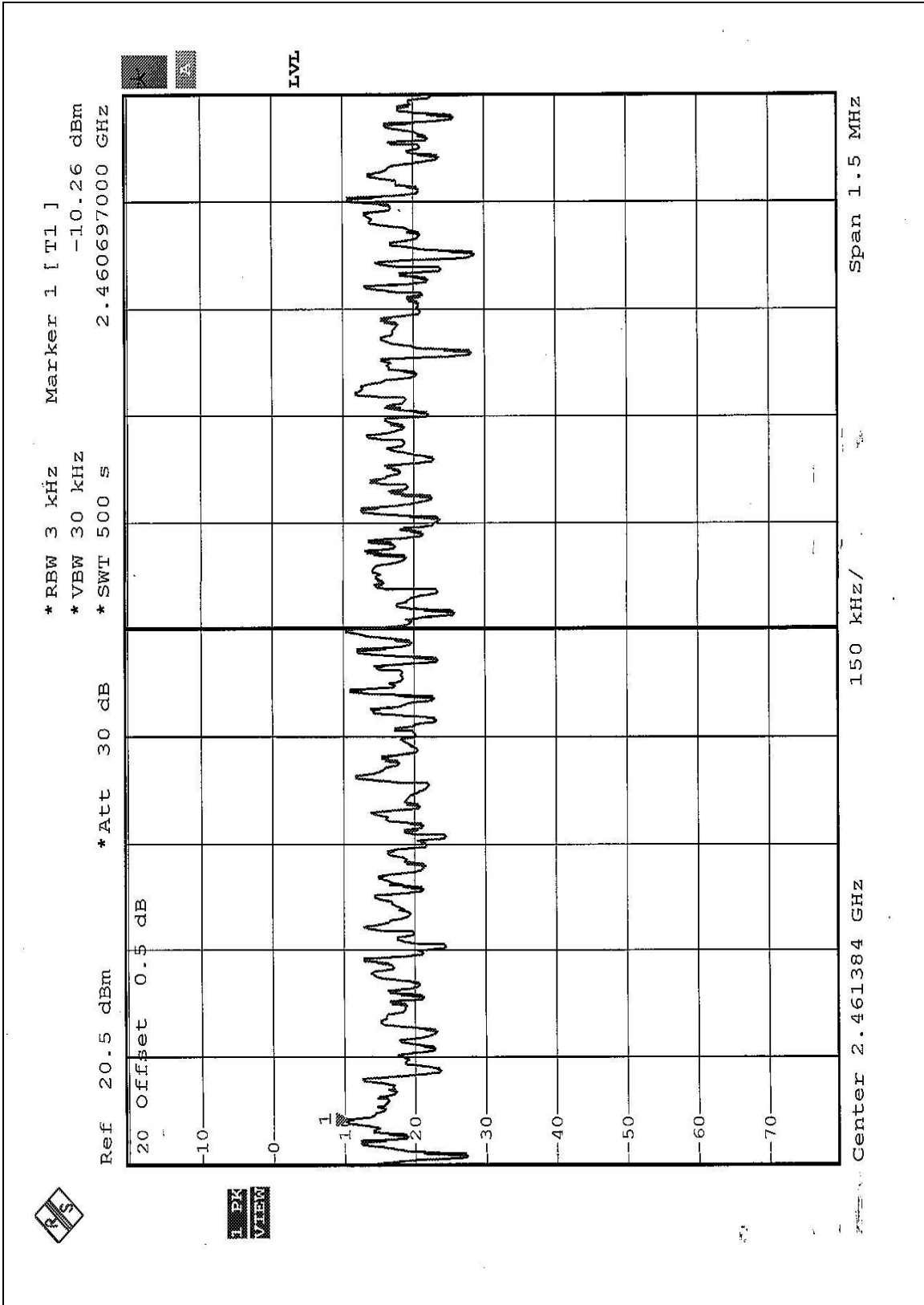



4.5.8 TEST RESULTS (B)

EUT	802.11g 54Mbps Wireless LAN Card	MODEL	WL 01 2454 NM1
INPUT POWER (SYSTEM)	120Vac, 60Hz	ENVIRONMENTAL CONDITIONS	20deg. C, 62%RH, 991hPa
TESTED BY: Stanely Hsu			

CHANNEL NUMBER	CHANNEL FREQUENCY (MHz)	RF POWER LEVEL IN 3KHz BW (dBm)	MAXIMUM LIMIT (dBm)	PASS/FAIL
1	2412	-20.34	8	PASS
6	2437	-19.51	8	PASS
11	2462	-18.66	8	PASS



CH1

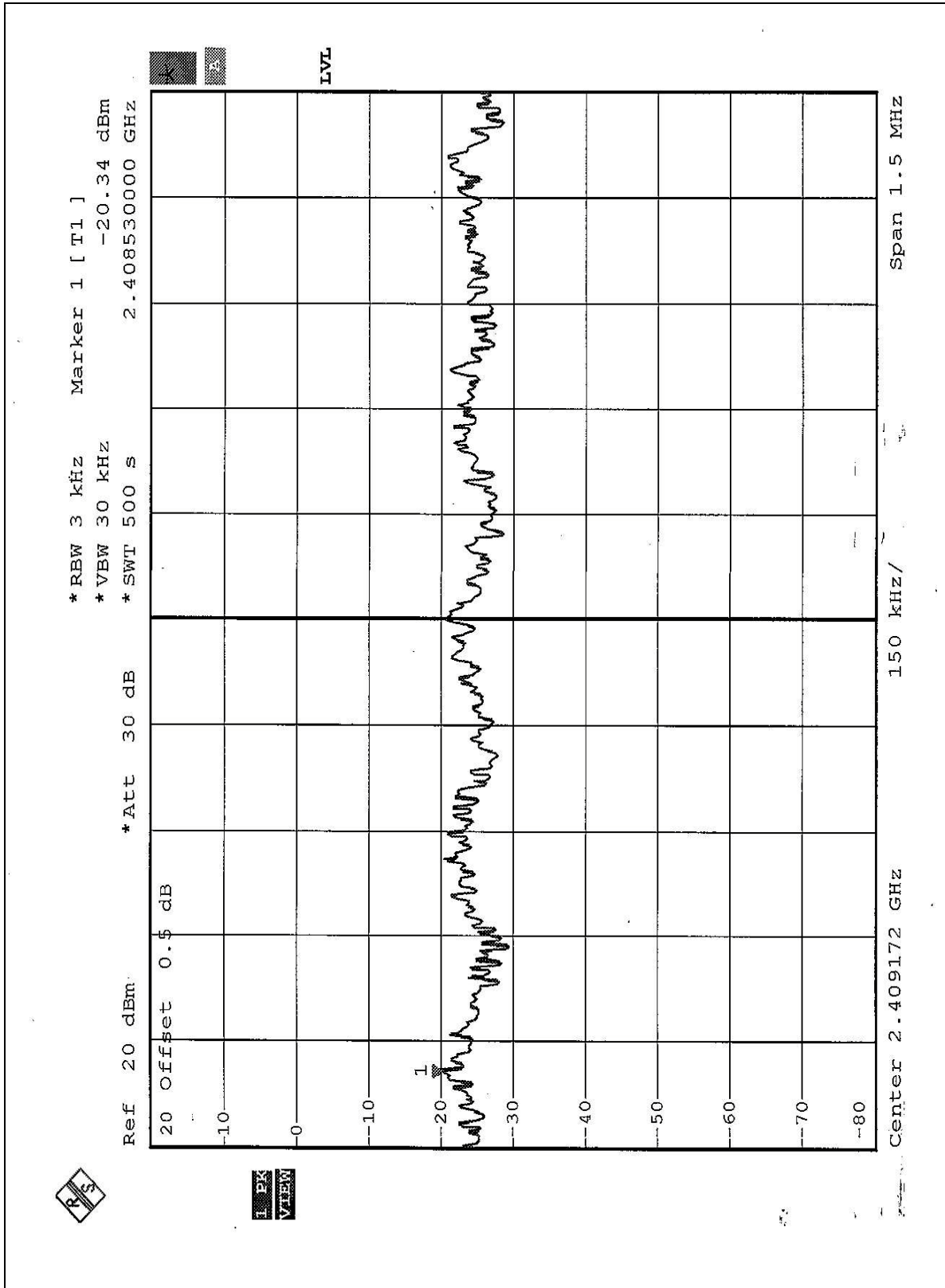



CH6

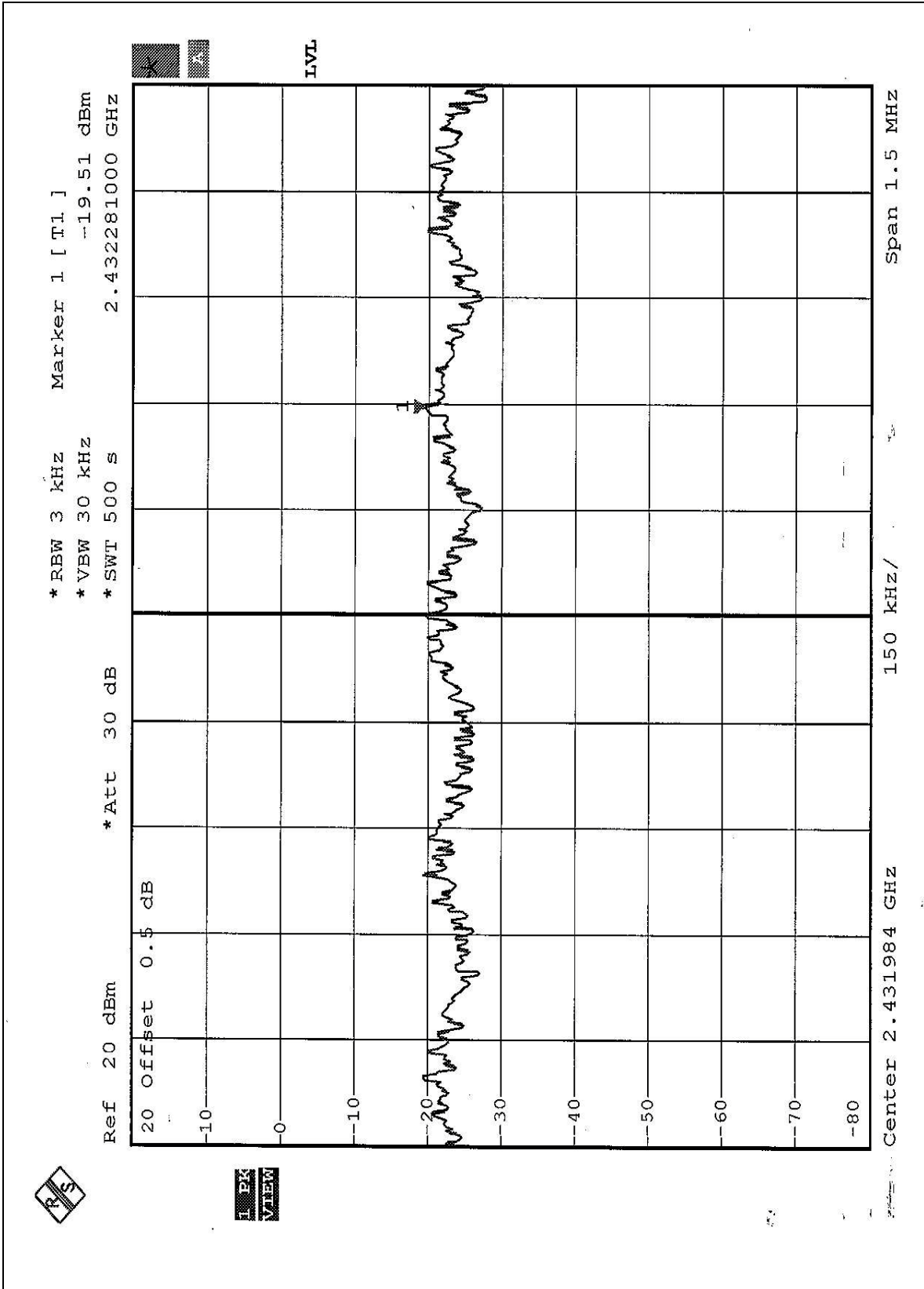



CH11

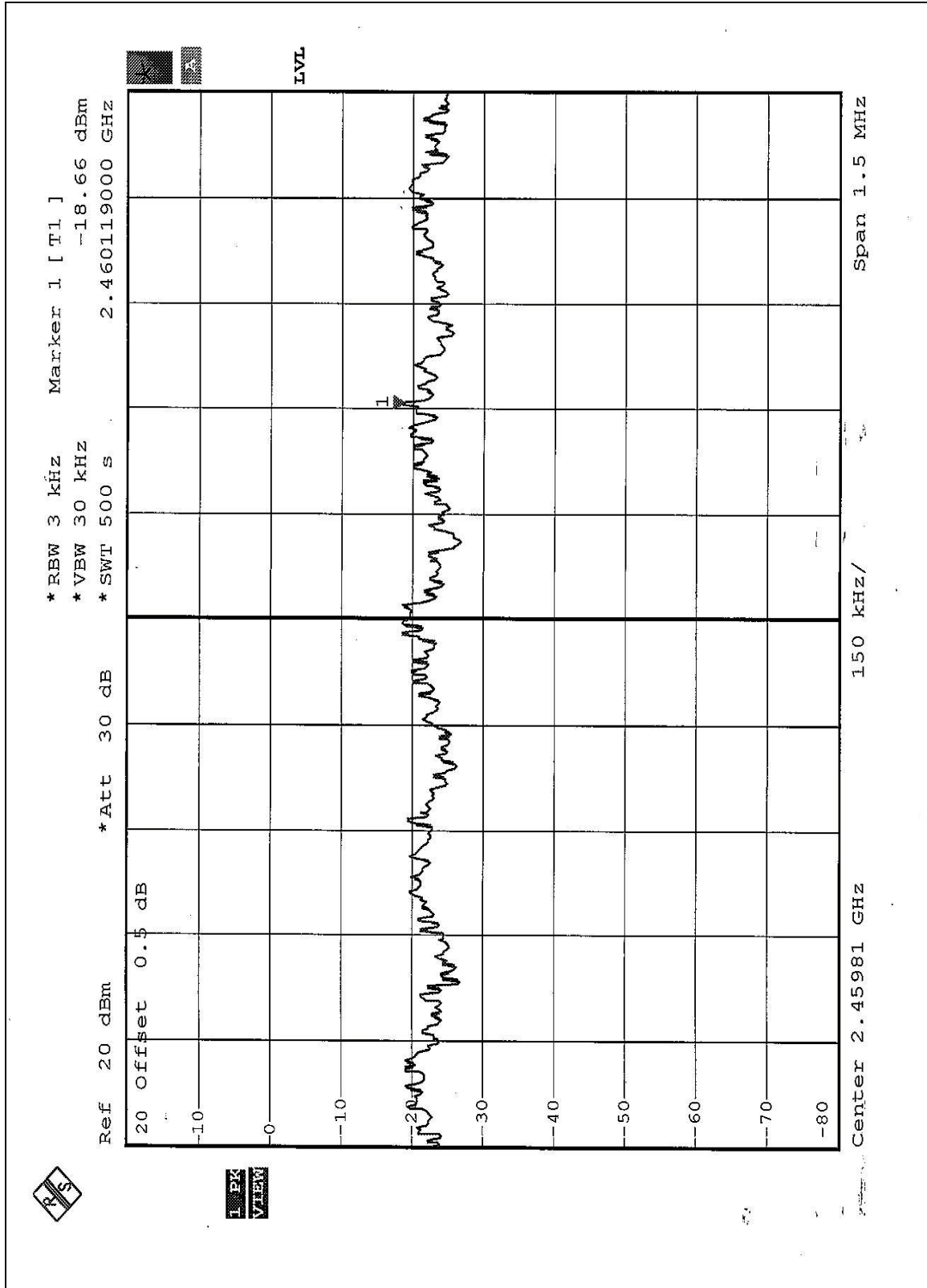



4.6 BAND EDGES MEASUREMENT

4.6.1 LIMITS OF BAND EDGES MEASUREMENT

Below -20dB of the highest emission level of operating band (in 100KHz Resolution Bandwidth).

4.6.2 TEST INSTRUMENTS

Description & Manufacturer	Model No.	Serial No.	Calibrated Until
SPECTRUM ANALYZER	FSEK30	100049	Aug. 12, 2004

NOTE:

The calibration interval of the above test instruments is 12 months and the calibrations are traceable to NML/ROC and NIST/USA.

4.6.3 TEST PROCEDURE

The transmitter output was connected to the spectrum analyzer via a low lose cable. Set both RBW and VBW of spectrum analyzer to 1MHz and 10Hz with suitable frequency span including 100MHz bandwidth from band edge. The band edges was measured and recorded.

4.6.4 DEVIATION FROM TEST STANDARD

No deviation

4.6.5 EUT OPERATING CONDITION

Same as Item 4.3.6



4.6.6 TEST RESULTS (A)

The spectrum plots are attached on the following 2 pages. D2 line indicates the highest level, D1 line indicates the 20dB offset below D2. It shows compliance with the requirement in part 15.247(C).

NOTE:

The band edge emission plot on the following first page shows 55.91dB delta between carrier maximum power and local maximum emission in restrict band (2.3900GHz). The emission of carrier strength list in the test result of channel 1 at the item 4.2.8 is 104.78dBuV/m, so the maximum field strength in restrict band is $104.78-55.91=48.87$ dBuV/m which is under 54dBuV/m limit.

The band edge emission plot on the following second page shows 53.40dB delta between carrier maximum power and local maximum emission in restrict band (2.4880GHz). The emission of carrier strength list in the test result of channel 11 at the item 4.2.8 is 104.10dBuV/m, so the maximum field strength in restrict band is $104.10-53.40=50.70$ dBuV/m which is under 54dBuV/m limit.

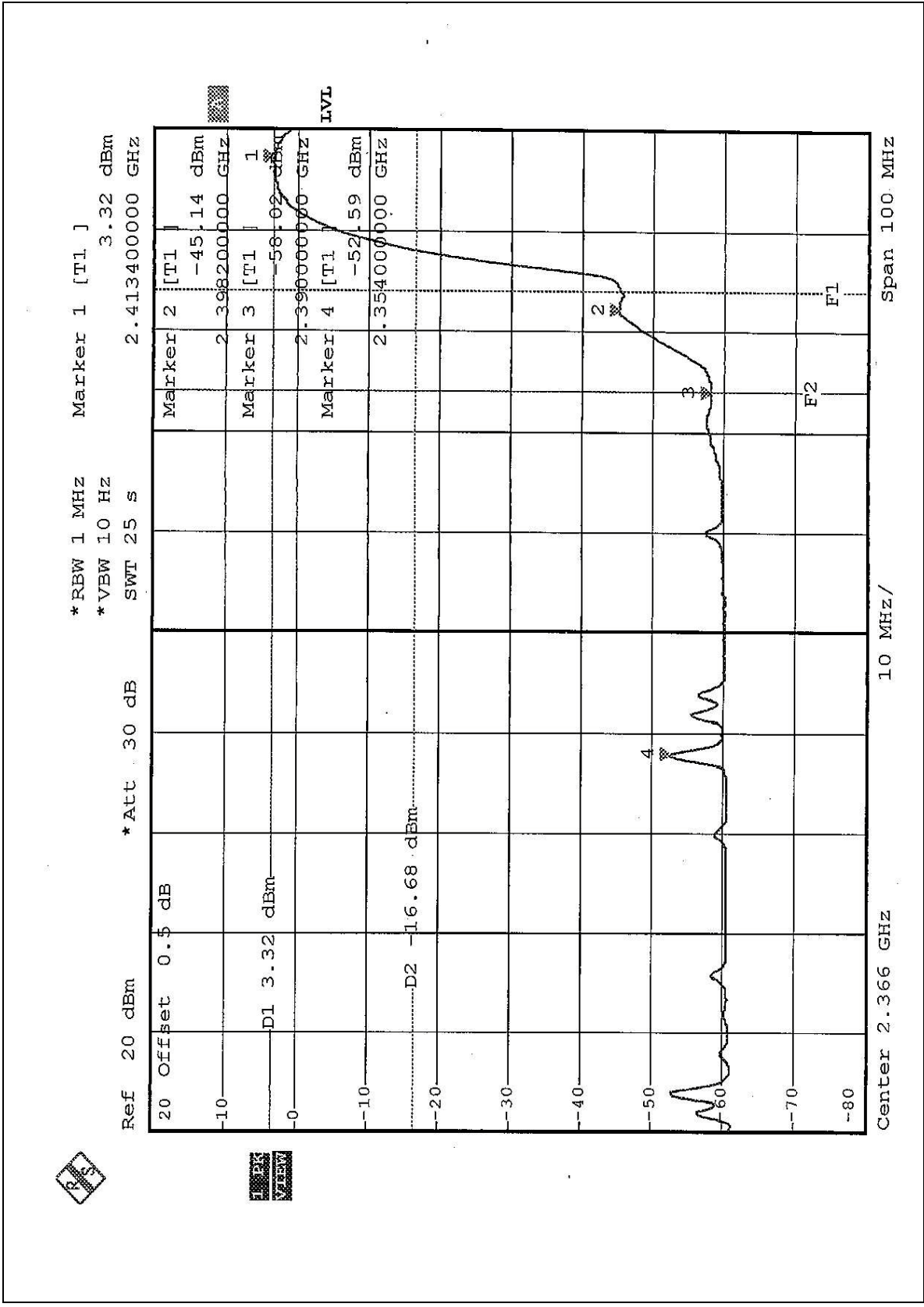

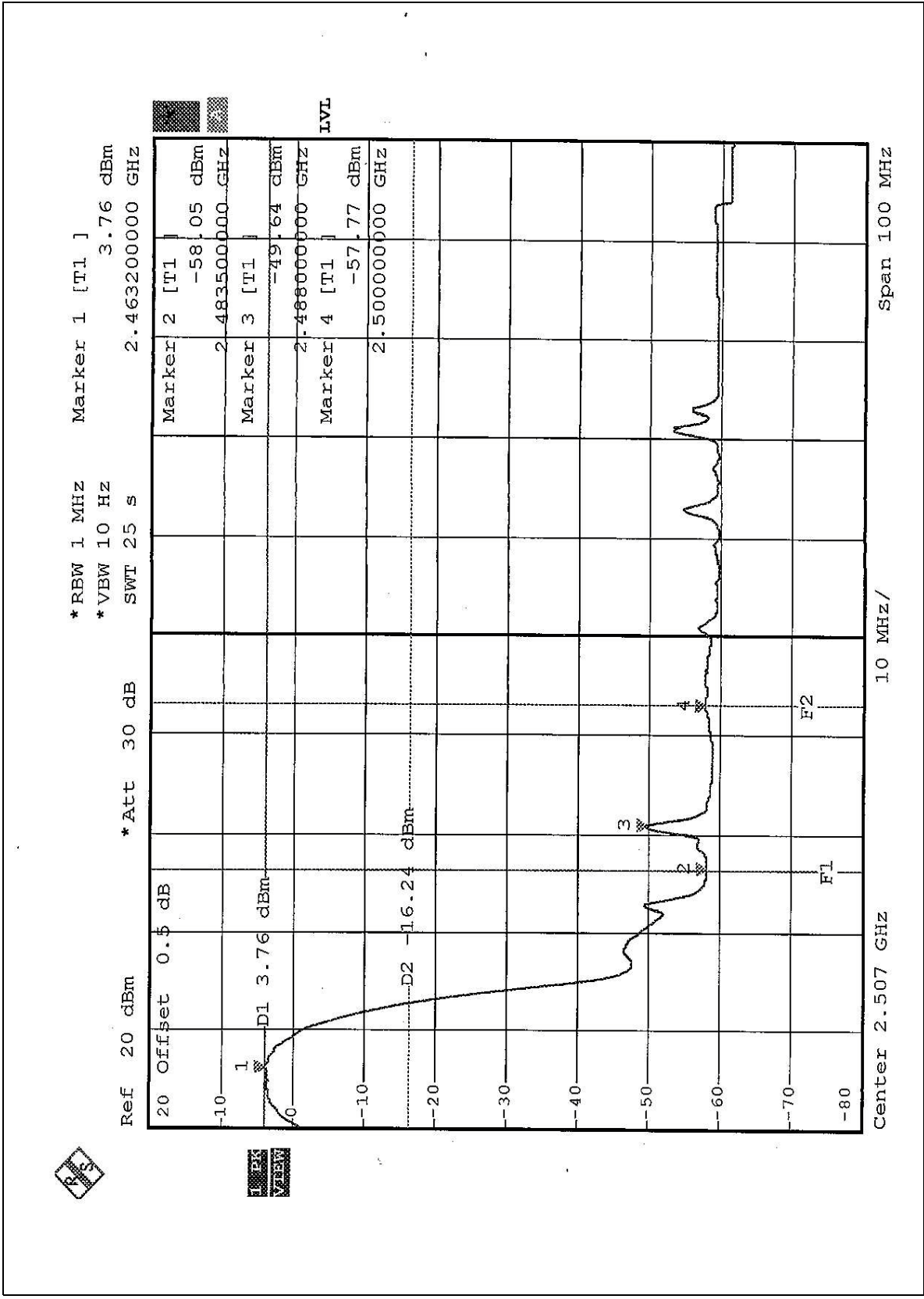



4.6.7 TEST RESULTS (B)

The spectrum plots are attached on the following 2 pages. D2 line indicates the highest level and D1 line indicates the 20dB offset below D2. It shows compliance with the requirement in part 15.247(C).

NOTE:

The band edge emission plot on the following first page shows 49.16dB delta between carrier maximum power and local maximum emission in restrict band (2.3580GHz). The emission of carrier strength list in the test result of channel 1 at the item 4.2.9 is 97.70dBuV/m, so the maximum field strength in restrict band is $97.70-49.16=48.54$ dBuV/m which is under 54dBuV/m limit.

The band edge emission plot on the following second page shows 44.07dB delta between carrier maximum power and local maximum emission in restrict band (2.4880GHz). The emission of carrier strength list in the test result of channel 11 at the item 4.2.9 is 96.80dBuV/m, so the maximum field strength in restrict band is $96.80-44.07=52.73$ dBuV/m which is under 54dBuV/m limit.

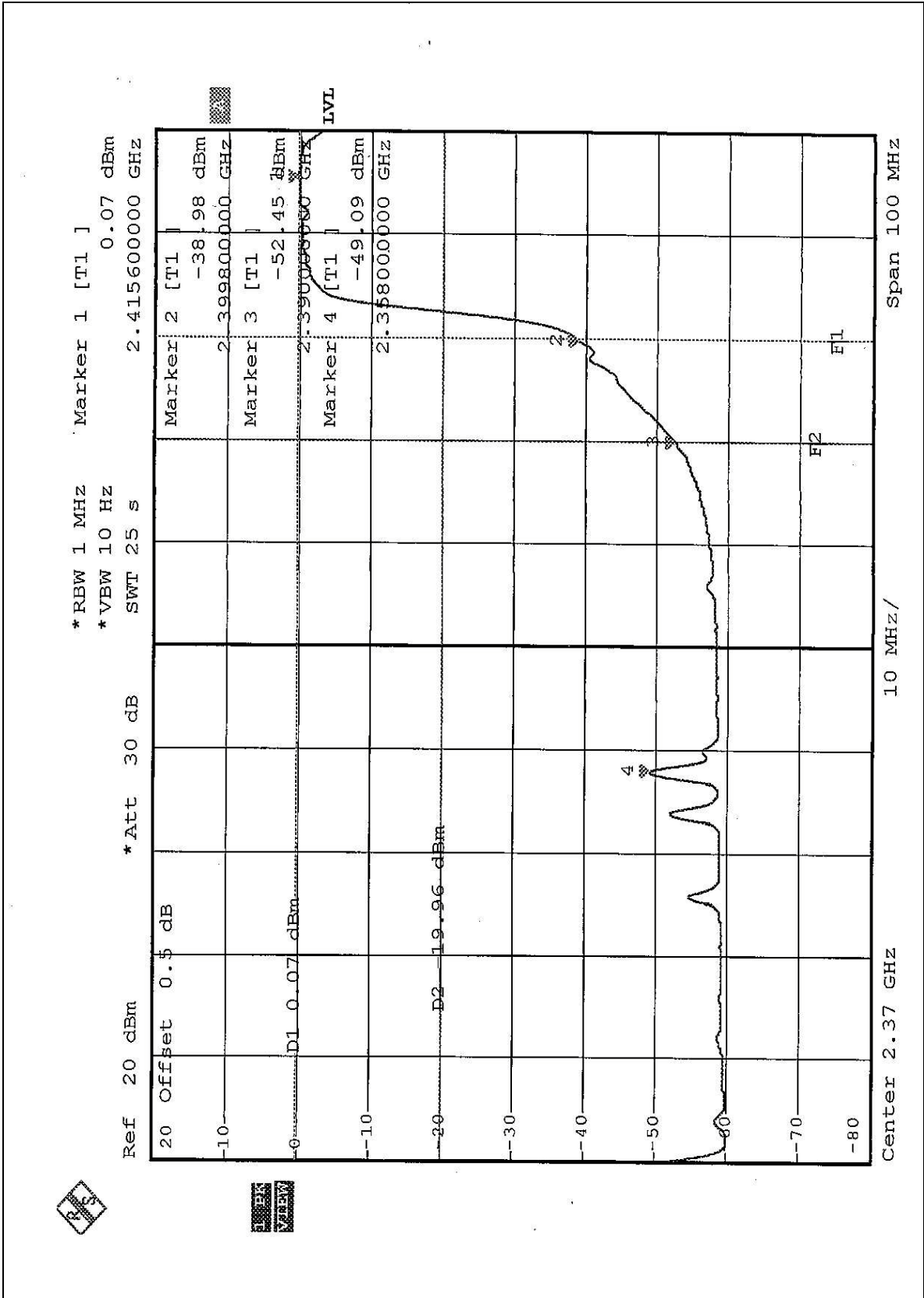

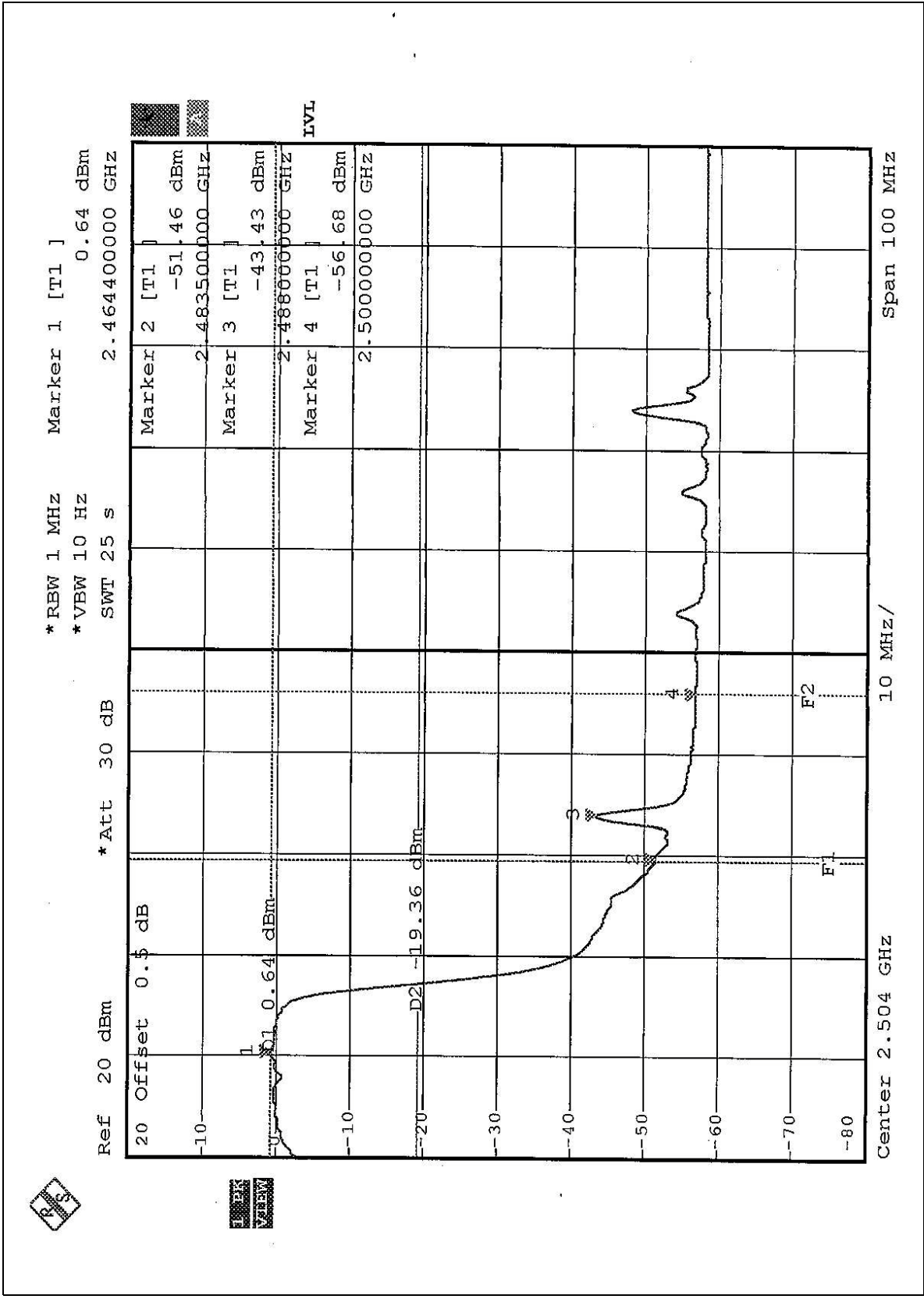



4.7 ANTENNA REQUIREMENT

4.7.1 STANDARD APPLICABLE

For intentional device, according to FCC 47 CFR Section 15.203, an intentional radiator shall be designed to ensure that no antenna other than that furnished by the responsible party shall be used with the device.

And according to FCC 47 CFR Section 15.247 (b), if transmitting antennas of directional gain greater than 6dBi are used, the power shall be reduced by the amount in dB that the directional gain of the antenna exceeds 6dBi.

4.7.2 ANTENNA CONNECTED CONSTRUCTION

The antenna used in this product is Printed antenna without connector. And the maximum Gain of this antenna is 0dBi.

5 PHOTOGRAPHS OF THE TEST CONFIGURATION CONDUCTED EMISSION TEST



RADIATED EMISSION TEST





6 INFORMATION ON THE TESTING LABORATORIES

We, ADT Corp., were founded in 1988 to provide our best service in EMC, Radio, Telecom and Safety consultation. Our laboratories are accredited and approved by the following approval agencies according to ISO/IEC 17025, Guide 25 or EN 45001:

USA	FCC, NVLAP, UL
Germany	TUV Rheinland
Japan	VCCI
Norway	NEMKO
Canada	INDUSTRY CANADA , CSA
R.O.C.	CNLA, BSMI, DGT
Netherlands	Telefication
Singapore	PSB , GOST-ASIA(MOU)
Russia	CERTIS(MOU)

Copies of accreditation certificates of our laboratories obtained from approval agencies can be downloaded from our web site:

www.adt.com.tw/index.5/phtml. If you have any comments, please feel free to contact us at the following:

Linko EMC/RF Lab

Tel: 886-2-26052180

Fax: 886-2-26052943

Hsin Chu EMC/RF Lab

Tel: 886-3-5935343

Fax: 886-3-5935342

Hwa Ya EMC/RF/Safety Lab

Tel: 886-3-3183232

Fax: 886-3-3185050

Linko RF & Telecom Lab

Tel: 886-3-3270910

Fax: 886-3-3270892

Email: service@mail.adt.com.tw

Web Site: www.adt.com.tw

The address and road map of all our labs can be found in our web site also.