

ANNEX 1 PROCESSING GAIN OF DIRECT SEQUENCE SPREAD SPECTRUM MEASUREMENT

1. LIMITS OF PROCESSING GAIN OF A DIRECT SEQUENCE SPREAD SPECTRUM MEASUREMENT

The limit of processing gain is 10dB

1.1 TEST INSTRUMENTS & SUPPORT UNIT

Description & Manufacturer	Model No.	Serial No.
Anritsu Spectrum Analyzer, 9kHz to 30GHz	MS2667C	M10281
Anritsu Signal Generator, 10kHz to 20GHz	68247B	984703
Hewlett Packard Power Meter,	HP438A	2743A04416
Hewlett Packard Power Sensor, -30 to 20dBm	8485A	2942A08387
Hewlett Packard Step Attenuator, 10dB steps	HP8496B	3247A18505
Mini-Circuits Power Splitter	ZN2PD-9G	NA
DELL Laptop Computer	Inspiron 5000e	NA
Campaq Laptop Computer	PPX	99125



1.2 METHOD OF MEASUREMENT

The processing gain may be measured using the CW jamming margin method. Section 4.7.4 shows the test configuration. The test consists of stepping a signal generator in 50 kHz increments across the passband of the system. At each point, the generator level required to produce the recommended Bit Error Rate (BER) is recorded. This level is jammer level. The output power of the transmitting unit is measured at the same point. The jammer to Signal (J/S) ratio is then calculated. Discard the worst 20% of the J/S data points. The lowest remaining J/S ratio is used when calculating the Process Gain.

The reference PER is specified as 8%. The corresponding Es/No (signal to noise ratio per symbol) is 16.4 dB. The curve is attached as below.

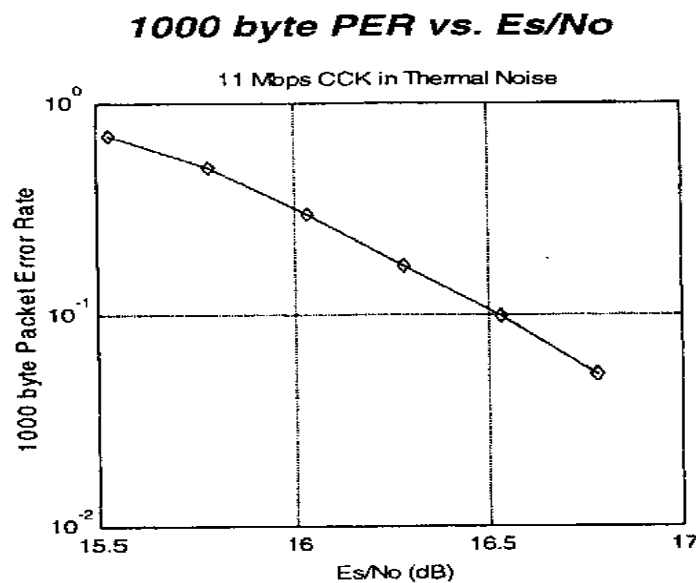

This value and the measured J/S ratio are used in the following equation to calculate the Process Gain (Gp) of the system.

$$G_p = (S/N)_o + M_j + L_{sys}$$

Where:

(S/N)_o: Signal to noise ratio for the chosen BER.



Mj : Maximum jammer to Signal Ratio recorded at the detected BER.

Lsys : System losses . For the purpose of this processing gain calculation, we assume Lsys at its minimum value of 2 dB.

TEST SETUP

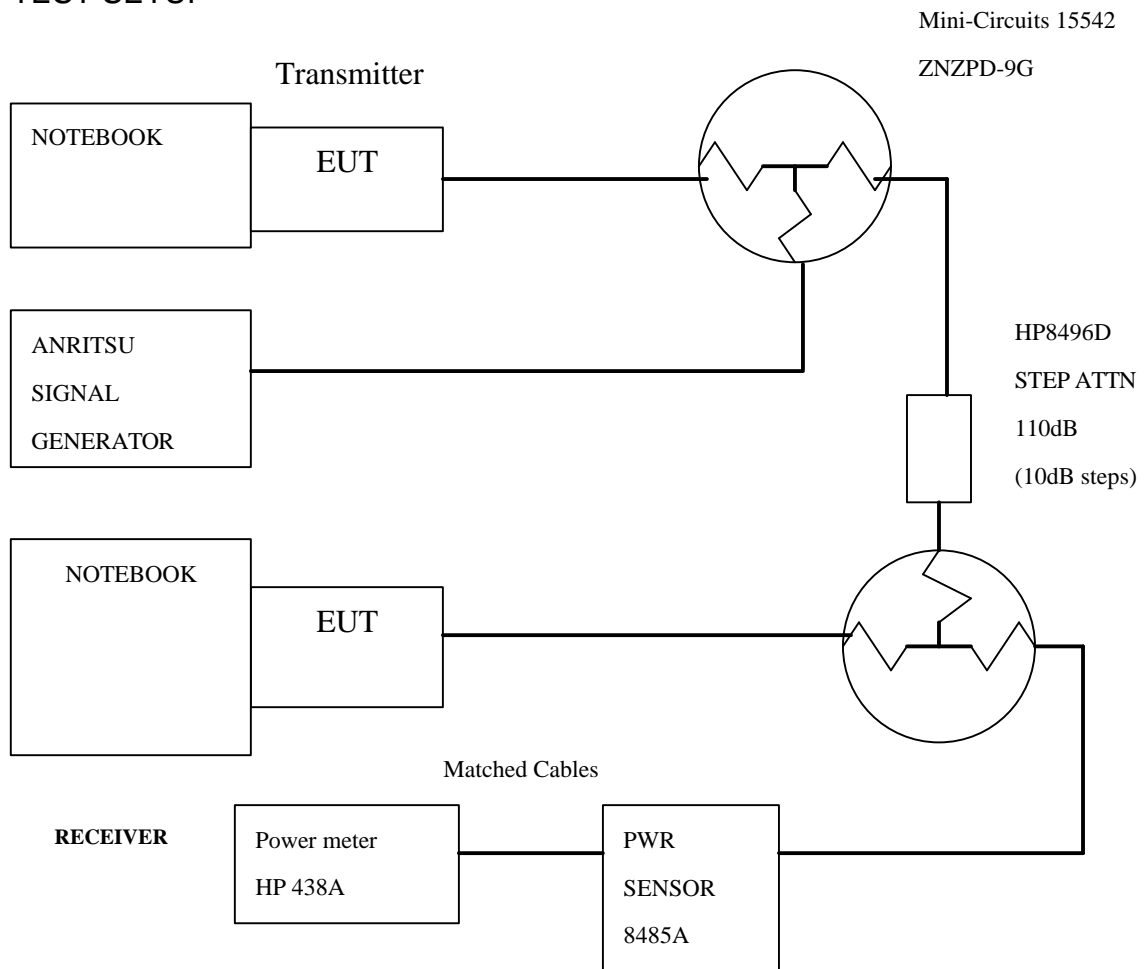



1.3 TEST PROCEDURES

Obtain the simplex link shown. Perform all independent instrumentation calibrations prior to this procedure. Set operating power levels using fixed and variable attenuators in system to meet the following objectives:

Signal Power at receiver approximately -55dBm (above thermal sensitivity such that thermal noise does not cause bit errors).

Signal Power at power meter between -20 and -30dBm for optimal linearity.

Use spectrum analyzer to monitor test.

Ensure that CW Jammer generator RF output is disabled and measure the power at the power meter port using the power meter. This is the relative signal power, S_r .

Disable Transmitter, and set CW Jammer generator RF output frequency equal to the carrier frequency and enable generator output. Set reference CW Jammer power level at power meter port 8.4dB below S_r (minimum J/S, or 10dB processing gain reference level). Note the power level setting on the generator, this is the reference CW Jammer power setting, J_r .

Disable CW Jammer, re-establish link. PER test should be operating essentially error - free.

Enable CW Jammer at the reference power level and verify that the PER test indicates a PER of less than 8%.

Alternatively, adjust the CW Jammer level to that which causes 8% PER and verify that the S/J is less than 8.4dB .

Repeat step 7 for uniform steps in frequency increments of 50kHz across the receiver passband with the CW Jammer. In this case the receiver passband is $\pm 8.5\text{MHz}$.

The numerical data associated with the following radio channel is tabulated and presented for Channel 1,6, and 11.

Note: Since the jamming signal will be blocked by the IF filter if the jamming frequency is far from the center of the carrier frequency. So, only those frequencies around carrier frequency are shown here.



1.4 EUT OPERATING CONDITION

The software provided by client to set the EUT to transmit at lowest, middle and highest channel.



1.5 TEST RESULTS

EUT	Wireless 11Mbps RF Module	Model	GL2411V4-01
Environmental Conditions	20 , 70%RH	Tested By	Gary Chang

Although the theoretical processing gain is lower than 10 dB, but the CCK coding provides an extra coding gain of 2.2dB.

11Mbps CHANNEL 1 Processing Gain				
Frequency (GHz)	Gp (dB)	(S/N) (dB)	Mj = J/S (dB)	Lsys (dB)
2.40800	13.1	16.4	-4.3	1
2.40805	13.0	16.4	-4.4	1
2.40810	13.1	16.4	-4.3	1
2.40815	13.3	16.4	-4.1	1
2.40820	13.2	16.4	-4.2	1
2.40825	13.0	16.4	-4.4	1
2.40830	12.7	16.4	-4.7	1
2.40835	12.7	16.4	-4.7	1
2.40840	12.4	16.4	-5.0	1
2.40845	12.2	16.4	-5.2	1
2.40850	12.3	16.4	-5.1	1
2.40855	12.4	16.4	-5.0	1
2.40860	12.4	16.4	-5.0	1
2.40865	12.2	16.4	-5.2	1
2.40870	12.0	16.4	-5.4	1
2.40875	12.4	16.4	-5.0	1
2.40880	12.3	16.4	-5.1	1
2.40885	12.3	16.4	-5.1	1
2.40890	12.0	16.4	-5.4	1
2.40895	11.9	16.4	-5.5	1
2.40900	11.7	16.4	-5.7	1
2.40950	11.4	16.4	-6.0	1



11Mbps CHANNEL 1 Processing Gain				
Frequency	Gp	(S/N)	Mj = J/S	Lsys
(GHz)	(dB)	(dB)	(dB)	(dB)
2.40955	11.4	16.4	-6.0	1
2.40960	11.4	16.4	-6.0	1
2.40965	11.5	16.4	-5.9	1
2.40970	11.5	16.4	-5.9	1
2.40975	11.4	16.4	-6.0	1
2.40980	11.2	16.4	-6.2	1
2.40985	11.1	16.4	-6.3	1
2.40990	11.0	16.4	-6.4	1
2.40995	11.0	16.4	-6.4	1
2.41000	11.1	16.4	-6.3	1
2.41005	11.0	16.4	-6.4	1
2.41010	11.0	16.4	-6.4	1
2.41015	10.9	16.4	-6.5	1
2.41020	11.2	16.4	-6.2	1
2.41025	11.4	16.4	-6.0	1
2.41030	11.3	16.4	-6.1	1
2.41035	11.5	16.4	-5.9	1
2.41040	11.2	16.4	-6.2	1
2.41045	11.2	16.4	-6.2	1
2.41050	11.4	16.4	-6.0	1
2.41055	11.1	16.4	-6.3	1
2.41060	11.3	16.4	-6.1	1
2.41065	11.4	16.4	-6.0	1
2.41070	11.4	16.4	-6.0	1
2.41075	11.3	16.4	-6.1	1
2.41080	11.3	16.4	-6.1	1
2.41085	11.5	16.4	-5.9	1
2.41090	11.6	16.4	-5.8	1
2.41095	11.6	16.4	-5.8	1
2.41100	11.6	16.4	-5.8	1
2.41105	11.4	16.4	-6.0	1
2.41110	11.4	16.4	-6.0	1
2.41115	11.5	16.4	-5.9	1
2.41120	11.5	16.4	-5.9	1



11Mbps CHANNEL 1 Processing Gain				
Frequency	Gp	(S/N)	Mj = J/S	Lsys
(GHz)	(dB)	(dB)	(dB)	(dB)
2.41125	11.6	16.4	-5.8	1
2.41130	11.7	16.4	-5.7	1
2.41135	11.4	16.4	-6.0	1
2.41140	11.4	16.4	-6.0	1
2.41145	11.5	16.4	-5.9	1
2.41150	11.3	16.4	-6.1	1
2.41155	11.2	16.4	-6.2	1
2.41160	11.6	16.4	-5.8	1
2.41165	11.5	16.4	-5.9	1
2.41170	11.4	16.4	-6.0	1
2.41175	11.5	16.4	-5.9	1
2.41180	11.3	16.4	-6.1	1
2.41185	11.2	16.4	-6.2	1
2.41190	11.0	16.4	-6.4	1
2.41195	10.8	16.4	-6.6	1
2.41200	11.0	16.4	-6.4	1
2.41205	11.0	16.4	-6.4	1
2.41210	11.1	16.4	-6.3	1
2.41215	11.3	16.4	-6.1	1
2.41220	11.6	16.4	-5.8	1
2.41225	11.5	16.4	-5.9	1
2.41230	11.7	16.4	-5.7	1
2.41235	11.7	16.4	-5.7	1
2.41240	11.7	16.4	-5.7	1
2.41245	11.6	16.4	-5.8	1
2.41250	11.5	16.4	-5.9	1
2.41255	11.6	16.4	-5.8	1
2.41260	11.5	16.4	-5.9	1
2.41265	11.6	16.4	-5.8	1
2.41270	11.6	16.4	-5.8	1
2.41275	11.5	16.4	-5.9	1
2.41280	11.9	16.4	-5.5	1
2.41285	11.8	16.4	-5.6	1
2.41290	11.9	16.4	-5.5	1
2.41295	11.9	16.4	-5.5	1
2.41300	11.9	16.4	-5.5	1



11Mbps CHANNEL 1 Processing Gain				
Frequency	Gp	(S/N)	Mj = J/S	Lsys
(GHz)	(dB)	(dB)	(dB)	(dB)
2.41305	11.9	16.4	-5.5	1
2.41310	11.8	16.4	-5.6	1
2.41315	11.8	16.4	-5.6	1
2.41320	11.6	16.4	-5.8	1
2.41325	11.6	16.4	-5.8	1
2.41330	11.5	16.4	-5.9	1
2.41335	11.6	16.4	-5.8	1
2.41340	11.4	16.4	-6.0	1
2.41345	11.7	16.4	-5.7	1
2.41350	11.6	16.4	-5.8	1
2.41355	11.6	16.4	-5.8	1
2.41360	11.7	16.4	-5.7	1
2.41365	11.8	16.4	-5.6	1
2.41370	11.7	16.4	-5.7	1
2.41375	11.7	16.4	-5.7	1
2.41380	11.5	16.4	-5.9	1
2.41385	11.5	16.4	-5.9	1
2.41390	11.5	16.4	-5.9	1
2.41395	11.4	16.4	-6.0	1
2.41400	11.2	16.4	-6.2	1
2.41405	11.1	16.4	-6.3	1
2.41410	11.1	16.4	-6.3	1
2.41415	11.2	16.4	-6.2	1
2.41420	11.3	16.4	-6.1	1
2.41425	11.2	16.4	-6.2	1
2.41430	11.4	16.4	-6.0	1
2.41435	11.6	16.4	-5.8	1
2.41440	11.6	16.4	-5.8	1
2.41445	11.6	16.4	-5.8	1
2.41450	11.4	16.4	-6.0	1
2.41455	11.4	16.4	-6.0	1
2.41460	11.4	16.4	-6.0	1
2.41465	11.2	16.4	-6.2	1
2.41470	11.4	16.4	-6.0	1
2.41475	11.3	16.4	-6.1	1
2.41480	11.5	16.4	-5.9	1



11Mbps CHANNEL 1 Processing Gain				
Frequency	Gp	(S/N)	Mj = J/S	Lsys
(GHz)	(dB)	(dB)	(dB)	(dB)
2.41485	11.6	16.4	-5.8	1
2.41490	11.6	16.4	-5.8	1
2.41495	11.7	16.4	-5.7	1
2.41500	12.0	16.4	-5.4	1
2.41505	11.9	16.4	-5.5	1
2.41510	12.1	16.4	-5.3	1
2.41515	12.1	16.4	-5.3	1
2.41520	12.1	16.4	-5.3	1
2.41525	12.1	16.4	-5.3	1
2.41530	12.0	16.4	-5.4	1
2.41535	12.2	16.4	-5.2	1
2.41540	12.0	16.4	-5.4	1
2.41545	12.2	16.4	-5.2	1
2.41550	12.1	16.4	-5.3	1
2.41555	12.3	16.4	-5.1	1
2.41560	12.3	16.4	-5.1	1
2.41565	12.5	16.4	-4.9	1
2.41570	12.6	16.4	-4.8	1
2.41575	12.7	16.4	-4.7	1
2.41580	12.9	16.4	-4.5	1
2.41585	12.7	16.4	-4.7	1
2.41590	12.7	16.4	-4.7	1
2.41595	12.9	16.4	-4.5	1
2.41600	12.7	16.4	-4.7	1
2.41605	12.8	16.4	-4.6	1
2.41610	13.0	16.4	-4.4	1
2.41615	12.9	16.4	-4.5	1
2.41620	12.8	16.4	-4.6	1
2.41625	13.1	16.4	-4.3	1
2.41630	13.2	16.4	-4.2	1
2.41635	13.4	16.4	-4.0	1
2.41640	13.7	16.4	-3.7	1
2.41645	13.6	16.4	-3.8	1
2.41650	13.6	16.4	-3.8	1
2.41655	13.7	16.4	-3.7	1
2.41660	13.8	16.4	-3.6	1

11Mbps CHANNEL 1 Processing Gain				
Frequency	Gp	(S/N)	Mj = J/S	Lsys
(GHz)	(dB)	(dB)	(dB)	(dB)
2.41665	13.7	16.4	-3.7	1
2.41670	13.7	16.4	-3.7	1
2.41675	13.8	16.4	-3.6	1
2.41680	13.8	16.4	-3.6	1
2.41685	14.0	16.4	-3.4	1
2.41690	14.2	16.4	-3.2	1
2.41695	14.2	16.4	-3.2	1
2.41700	14.0	16.4	-3.4	1
2.41705	14.4	16.4	-3.0	1
2.41710	14.7	16.4	-2.7	1
2.41715	14.8	16.4	-2.6	1
2.41720	14.9	16.4	-2.5	1
2.41725	15.0	16.4	-2.4	1
2.41730	15.0	16.4	-2.4	1
2.41735	15.0	16.4	-2.4	1
2.41740	15.3	16.4	-2.1	1
2.41745	15.1	16.4	-2.3	1
2.41750	15.6	16.4	-1.8	1
2.41755	15.4	16.4	-2.0	1
2.41760	15.7	16.4	-1.7	1
2.41765	15.9	16.4	-1.5	1
2.41770	16.2	16.4	-1.2	1
2.41775	16.4	16.4	-1.0	1
2.41780	16.7	16.4	-0.7	1
2.41785	16.8	16.4	-0.6	1
2.41790	16.8	16.4	-0.6	1
2.41795	16.8	16.4	-0.6	1
2.41800	16.9	16.4	-0.5	1



11Mbps CHANNEL 6 Processing Gain				
Freq.	Gp	(S/N)	Mj = J/S	Lsys
(GHz)	(dB)	(dB)	(dB)	(dB)
2.43200	14.3	16.4	-3.1	1
2.43205	14.2	16.4	-3.2	1
2.43210	14.0	16.4	-3.4	1
2.43215	13.9	16.4	-3.5	1
2.43220	14.0	16.4	-3.4	1
2.43225	13.9	16.4	-3.5	1
2.43230	13.8	16.4	-3.6	1
2.43235	13.9	16.4	-3.5	1
2.43240	13.8	16.4	-3.6	1
2.43245	13.7	16.4	-3.7	1
2.43250	13.6	16.4	-3.8	1
2.43255	13.6	16.4	-3.8	1
2.43260	13.5	16.4	-3.9	1
2.43265	13.2	16.4	-4.2	1
2.43270	13.0	16.4	-4.4	1
2.43275	13.1	16.4	-4.3	1
2.43280	13.1	16.4	-4.3	1
2.43285	12.9	16.4	-4.5	1
2.43290	12.9	16.4	-4.5	1
2.43295	12.9	16.4	-4.5	1
2.43300	12.9	16.4	-4.5	1
2.43305	12.9	16.4	-4.5	1
2.43310	12.8	16.4	-4.6	1
2.43315	12.9	16.4	-4.5	1
2.43320	12.9	16.4	-4.5	1
2.43325	12.8	16.4	-4.6	1
2.43330	12.8	16.4	-4.6	1
2.43335	12.6	16.4	-4.8	1
2.43340	12.3	16.4	-5.1	1
2.43345	12.2	16.4	-5.2	1
2.43350	12.3	16.4	-5.1	1
2.43355	12.1	16.4	-5.3	1
2.43360	12.1	16.4	-5.3	1
2.43365	12.2	16.4	-5.2	1
2.43370	12.0	16.4	-5.4	1
2.43375	12.1	16.4	-5.3	1



11Mbps CHANNEL 6 Processing Gain				
Freq.	Gp	(S/N)	Mj = J/S	Lsys
(GHz)	(dB)	(dB)	(dB)	(dB)
2.43380	12.1	16.4	-5.3	1
2.43385	12.1	16.4	-5.3	1
2.43390	11.9	16.4	-5.5	1
2.43395	11.6	16.4	-5.8	1
2.43400	11.6	16.4	-5.8	1
2.43405	11.5	16.4	-5.9	1
2.43410	11.3	16.4	-6.1	1
2.43415	11.4	16.4	-6.0	1
2.43420	10.9	16.4	-6.5	1
2.43425	11.0	16.4	-6.4	1
2.43430	11.0	16.4	-6.4	1
2.43435	11.1	16.4	-6.3	1
2.43440	11.0	16.4	-6.4	1
2.43445	11.1	16.4	-6.3	1
2.43450	11.1	16.4	-6.3	1
2.43455	11.3	16.4	-6.1	1
2.43460	11.3	16.4	-6.1	1
2.43465	11.3	16.4	-6.1	1
2.43470	11.2	16.4	-6.2	1
2.43475	11.2	16.4	-6.2	1
2.43480	11.1	16.4	-6.3	1
2.43485	11.1	16.4	-6.3	1
2.43490	10.9	16.4	-6.5	1
2.43495	11.0	16.4	-6.4	1
2.43500	11.0	16.4	-6.4	1
2.43505	11.1	16.4	-6.3	1
2.43510	11.1	16.4	-6.3	1
2.43515	11.4	16.4	-6.0	1
2.43520	11.2	16.4	-6.2	1
2.43525	11.3	16.4	-6.1	1
2.43530	11.5	16.4	-5.9	1
2.43535	11.5	16.4	-5.9	1
2.43540	11.3	16.4	-6.1	1
2.43545	11.2	16.4	-6.2	1



11Mbps CHANNEL 6 Processing Gain				
Freq.	Gp	(S/N)	Mj = J/S	Lsys
(GHz)	(dB)	(dB)	(dB)	(dB)
2.43550	11.3	16.4	-6.1	1
2.43555	11.3	16.4	-6.1	1
2.43560	11.2	16.4	-6.2	1
2.43565	11.2	16.4	-6.2	1
2.43570	11.3	16.4	-6.1	1
2.43575	11.2	16.4	-6.2	1
2.43580	11.4	16.4	-6.0	1
2.43585	11.4	16.4	-6.0	1
2.43590	11.3	16.4	-6.1	1
2.43595	11.5	16.4	-5.9	1
2.43600	11.4	16.4	-6.0	1
2.43605	11.5	16.4	-5.9	1
2.43610	11.4	16.4	-6.0	1
2.43615	11.5	16.4	-5.9	1
2.43620	11.4	16.4	-6.0	1
2.43625	11.4	16.4	-6.0	1
2.43630	11.5	16.4	-5.9	1
2.43635	11.3	16.4	-6.1	1
2.43640	11.3	16.4	-6.1	1
2.43645	11.3	16.4	-6.1	1
2.43650	11.2	16.4	-6.2	1
2.43655	11.5	16.4	-5.9	1
2.43660	11.4	16.4	-6.0	1
2.43665	11.5	16.4	-5.9	1
2.43670	11.5	16.4	-5.9	1
2.43675	11.4	16.4	-6.0	1
2.43680	11.2	16.4	-6.2	1
2.43685	10.9	16.4	-6.5	1
2.43690	11.0	16.4	-6.4	1
2.43695	10.8	16.4	-6.6	1
2.43700	11.0	16.4	-6.4	1
2.43705	10.8	16.4	-6.6	1
2.43710	11.1	16.4	-6.3	1
2.43715	11.3	16.4	-6.1	1



11Mbps CHANNEL 6 Processing Gain				
Freq.	Gp	(S/N)	Mj = J/S	Lsys
(GHz)	(dB)	(dB)	(dB)	(dB)
2.43720	11.2	16.4	-6.2	1
2.43725	11.5	16.4	-5.9	1
2.43730	11.6	16.4	-5.8	1
2.43735	11.7	16.4	-5.7	1
2.43740	11.4	16.4	-6.0	1
2.43745	11.3	16.4	-6.1	1
2.43750	11.4	16.4	-6.0	1
2.43755	11.4	16.4	-6.0	1
2.43760	11.4	16.4	-6.0	1
2.43765	11.4	16.4	-6.0	1
2.43770	11.4	16.4	-6.0	1
2.43775	11.4	16.4	-6.0	1
2.43780	11.6	16.4	-5.8	1
2.43785	11.7	16.4	-5.7	1
2.43790	11.9	16.4	-5.5	1
2.43795	11.8	16.4	-5.6	1
2.43800	11.7	16.4	-5.7	1
2.43805	11.6	16.4	-5.8	1
2.43810	11.6	16.4	-5.8	1
2.43815	11.5	16.4	-5.9	1
2.43820	11.5	16.4	-5.9	1
2.43825	11.5	16.4	-5.9	1
2.43830	11.5	16.4	-5.9	1
2.43835	11.3	16.4	-6.1	1
2.43840	11.4	16.4	-6.0	1
2.43845	11.3	16.4	-6.1	1
2.43850	11.4	16.4	-6.0	1
2.43855	11.4	16.4	-6.0	1
2.43860	11.5	16.4	-5.9	1
2.43865	11.4	16.4	-6.0	1
2.43870	11.3	16.4	-6.1	1
2.43875	11.3	16.4	-6.1	1
2.43880	11.4	16.4	-6.0	1
2.43885	11.4	16.4	-6.0	1

11Mbps CHANNEL 6 Processing Gain				
Freq.	Gp	(S/N)	Mj = J/S	Lsys
(GHz)	(dB)	(dB)	(dB)	(dB)
2.43890	11.1	16.4	-6.3	1
2.48950	11.1	16.4	-6.3	1
2.43900	11.2	16.4	-6.2	1
2.43905	11.1	16.4	-6.3	1
2.43910	11.1	16.4	-6.3	1
2.43915	11.0	16.4	-6.4	1
2.43920	11.0	16.4	-6.4	1
2.43925	11.0	16.4	-6.4	1
2.43930	11.3	16.4	-6.1	1
2.43935	11.1	16.4	-6.3	1
2.43940	11.3	16.4	-6.1	1
2.43945	11.4	16.4	-6.0	1
2.43950	11.2	16.4	-6.2	1
2.43955	11.3	16.4	-6.1	1
2.43960	11.3	16.4	-6.1	1
2.43965	11.4	16.4	-6.0	1
2.43970	11.1	16.4	-6.3	1
2.43975	10.9	16.4	-6.5	1
2.43980	11.1	16.4	-6.3	1
2.43985	11.1	16.4	-6.3	1
2.43990	11.3	16.4	-6.1	1
2.43995	11.7	16.4	-5.7	1
2.44000	11.8	16.4	-5.6	1
2.44005	12.0	16.4	-5.4	1
2.44010	12.0	16.4	-5.4	1
2.44015	12.1	16.4	-5.3	1
2.44020	12.2	16.4	-5.2	1
2.44025	12.0	16.4	-5.4	1
2.44030	12.1	16.4	-5.3	1
2.44035	11.9	16.4	-5.5	1
2.44040	12.0	16.4	-5.4	1
2.44045	12.1	16.4	-5.3	1
2.44050	12.0	16.4	-5.4	1
2.44055	12.3	16.4	-5.1	1



11Mbps CHANNEL 6 Processing Gain				
Freq.	Gp	(S/N)	Mj = J/S	Lsys
(GHz)	(dB)	(dB)	(dB)	(dB)
2.44060	12.3	16.4	-5.1	1
2.44065	12.6	16.4	-4.8	1
2.44070	12.8	16.4	-4.6	1
2.44075	12.7	16.4	-4.7	1
2.44080	12.8	16.4	-4.6	1
2.44085	12.8	16.4	-4.6	1
2.44090	12.7	16.4	-4.7	1
2.44095	12.8	16.4	-4.6	1
2.44100	12.9	16.4	-4.5	1
2.44105	12.9	16.4	-4.5	1
2.44110	12.7	16.4	-4.7	1
2.44115	13.0	16.4	-4.4	1
2.44120	13.0	16.4	-4.4	1
2.44125	13.1	16.4	-4.3	1
2.44130	13.3	16.4	-4.1	1
2.44135	13.4	16.4	-4.0	1
2.44140	13.4	16.4	-4.0	1
2.44145	13.7	16.4	-3.7	1
2.44150	13.8	16.4	-3.6	1
2.44155	13.8	16.4	-3.6	1
2.44160	13.6	16.4	-3.8	1
2.44165	13.7	16.4	-3.7	1
2.44170	13.7	16.4	-3.7	1
2.44175	13.7	16.4	-3.7	1
2.44180	13.8	16.4	-3.6	1
2.44185	14.1	16.4	-3.3	1
2.44190	14.2	16.4	-3.2	1
2.44195	14.5	16.4	-2.9	1
2.44200	14.4	16.4	-3.0	1



11Mbps CHANNEL 11 Processing Gain				
Freq.	Gp	(S/N)	Mj = J/S	Lsys
(GHz)	(dB)	(dB)	(dB)	(dB)
2.45700	14.5	16.4	-2.9	1
2.45705	14.5	16.4	-2.9	1
2.45710	14.1	16.4	-3.3	1
2.45715	14.2	16.4	-3.2	1
2.45720	13.9	16.4	-3.5	1
2.45725	14.1	16.4	-3.3	1
2.45730	13.8	16.4	-3.6	1
2.45735	13.9	16.4	-3.5	1
2.45740	13.9	16.4	-3.5	1
2.45745	14.0	16.4	-3.4	1
2.45750	13.7	16.4	-3.7	1
2.45755	13.6	16.4	-3.8	1
2.45760	13.5	16.4	-3.9	1
2.45765	13.4	16.4	-4.0	1
2.45770	13.3	16.4	-4.1	1
2.45775	13.2	16.4	-4.2	1
2.45780	13.1	16.4	-4.3	1
2.45785	13.1	16.4	-4.3	1
2.45790	13.1	16.4	-4.3	1
2.45795	13.2	16.4	-4.2	1
2.45800	13.1	16.4	-4.3	1
2.45805	13.0	16.4	-4.4	1
2.45810	13.0	16.4	-4.4	1
2.45815	13.2	16.4	-4.2	1
2.45820	13.0	16.4	-4.4	1
2.45825	12.8	16.4	-4.6	1
2.45830	12.8	16.4	-4.6	1
2.45835	12.8	16.4	-4.6	1
2.45840	12.6	16.4	-4.8	1
2.45845	12.6	16.4	-4.8	1
2.45850	12.4	16.4	-5.0	1
2.45855	12.4	16.4	-5.0	1
2.45860	12.5	16.4	-4.9	1
2.45865	12.5	16.4	-4.9	1



11Mbps CHANNEL 11 Processing Gain				
Freq.	Gp	(S/N)	Mj = J/S	Lsys
(GHz)	(dB)	(dB)	(dB)	(dB)
2.45870	12.4	16.4	-5.0	1
2.45875	12.4	16.4	-5.0	1
2.45880	12.5	16.4	-4.9	1
2.45885	12.5	16.4	-4.9	1
2.45890	12.2	16.4	-5.2	1
2.45895	12.3	16.4	-5.1	1
2.45900	12.0	16.4	-5.4	1
2.45905	11.9	16.4	-5.5	1
2.45910	11.7	16.4	-5.7	1
2.45915	11.9	16.4	-5.5	1
2.45920	11.6	16.4	-5.8	1
2.45925	11.6	16.4	-5.8	1
2.45930	11.4	16.4	-6.0	1
2.45935	11.8	16.4	-5.6	1
2.45940	11.7	16.4	-5.7	1
2.45945	11.8	16.4	-5.6	1
2.45950	11.7	16.4	-5.7	1
2.45955	11.7	16.4	-5.7	1
5.45960	11.8	16.4	-5.6	1
2.45965	11.6	16.4	-5.8	1
2.45970	11.8	16.4	-5.6	1
2.45975	11.7	16.4	-5.7	1
2.45980	11.5	16.4	-5.9	1
2.45985	11.5	16.4	-5.9	1
2.45990	11.2	16.4	-6.2	1
2.45995	11.3	16.4	-6.1	1
2.46000	11.3	16.4	-6.1	1
2.46005	11.3	16.4	-6.1	1
2.46010	11.5	16.4	-5.9	1
2.46015	11.5	16.4	-5.9	1
2.46020	11.5	16.4	-5.9	1
2.46025	11.7	16.4	-5.7	1
2.46030	11.6	16.4	-5.8	1
2.46035	11.7	16.4	-5.7	1
2.46040	11.4	16.4	-6.0	1
2.46045	11.4	16.4	-6.0	1

11Mbps CHANNEL 11 Processing Gain				
Freq.	Gp	(S/N)	Mj = J/S	Lsys
(GHz)	(dB)	(dB)	(dB)	(dB)
2.46050	11.6	16.4	-5.8	1
2.46055	11.5	16.4	-5.9	1
2.46060	11.5	16.4	-5.9	1
2.46065	11.4	16.4	-6.0	1
2.46070	11.5	16.4	-5.9	1
2.46075	11.6	16.4	-5.8	1
2.46080	11.7	16.4	-5.7	1
2.46085	12.0	16.4	-5.4	1
2.46090	11.9	16.4	-5.5	1
2.46095	12.0	16.4	-5.4	1
2.46100	12.1	16.4	-5.3	1
2.46105	11.9	16.4	-5.5	1
2.46110	12.2	16.4	-5.2	1
2.46115	11.9	16.4	-5.5	1
2.46120	12.1	16.4	-5.3	1
2.46125	12.0	16.4	-5.4	1
2.46130	12.2	16.4	-5.2	1
2.46135	12.0	16.4	-5.4	1
2.46140	12.1	16.4	-5.3	1
2.46145	12.0	16.4	-5.4	1
2.46150	12.3	16.4	-5.1	1
2.46155	12.3	16.4	-5.1	1
2.46160	12.3	16.4	-5.1	1
2.46165	12.2	16.4	-5.2	1
2.46170	12.5	16.4	-4.9	1
2.46175	12.3	16.4	-5.1	1
2.46180	12.4	16.4	-5.0	1
2.46185	12.1	16.4	-5.3	1
2.46190	11.8	16.4	-5.6	1
2.46195	12.0	16.4	-5.4	1
2.46200	11.9	16.4	-5.5	1
2.46205	12.1	16.4	-5.3	1
2.46210	12.0	16.4	-5.4	1
2.46215	12.1	16.4	-5.3	1



11Mbps CHANNEL 11 Processing Gain				
Freq.	Gp	(S/N)	Mj = J/S	Lsys
(GHz)	(dB)	(dB)	(dB)	(dB)
2.46220	12.4	16.4	-5.0	1
2.46225	12.4	16.4	-5.0	1
2.46230	12.5	16.4	-4.9	1
2.46235	12.4	16.4	-5.0	1
2.46240	12.6	16.4	-4.8	1
2.46245	12.2	16.4	-5.2	1
2.46250	12.2	16.4	-5.2	1
2.46255	12.2	16.4	-5.2	1
2.46260	12.5	16.4	-4.9	1
2.46265	12.2	16.4	-5.2	1
2.46270	12.2	16.4	-5.2	1
2.46275	12.3	16.4	-5.1	1
2.46280	12.3	16.4	-5.1	1
2.46285	12.4	16.4	-5.0	1
2.46290	12.3	16.4	-5.1	1
2.46295	12.3	16.4	-5.1	1
2.46300	12.2	16.4	-5.2	1
2.46305	12.2	16.4	-5.2	1
2.46310	12.1	16.4	-5.3	1
2.46315	11.9	16.4	-5.5	1
2.46320	11.8	16.4	-5.6	1
2.46325	11.8	16.4	-5.6	1
2.46330	11.8	16.4	-5.6	1
2.46335	11.7	16.4	-5.7	1
2.46340	11.8	16.4	-5.6	1
2.46345	11.9	16.4	-5.5	1
2.46350	11.9	16.4	-5.5	1
2.46355	11.9	16.4	-5.5	1
2.46360	12.1	16.4	-5.3	1
2.46365	11.9	16.4	-5.5	1
2.46370	12.1	16.4	-5.3	1
2.46375	12.1	16.4	-5.3	1
2.46380	12.1	16.4	-5.3	1
2.46385	12.1	16.4	-5.3	1



11Mbps CHANNEL 11 Processing Gain				
Freq. (GHz)	Gp (dB)	(S/N) (dB)	Mj = J/S (dB)	Lsys (dB)
2.46390	11.9	16.4	-5.5	1
2.46395	11.7	16.4	-5.7	1
2.46400	12.0	16.4	-5.4	1
2.46405	11.9	16.4	-5.5	1
2.46410	11.7	16.4	-5.7	1
2.46415	11.9	16.4	-5.5	1
2.46420	11.7	16.4	-5.7	1
2.46425	11.9	16.4	-5.5	1
2.46430	12.1	16.4	-5.3	1
2.46435	12.2	16.4	-5.2	1
4.46440	12.2	16.4	-5.2	1
2.46445	12.2	16.4	-5.2	1
2.46450	12.0	16.4	-5.4	1
2.46455	12.1	16.4	-5.3	1
2.46460	12.0	16.4	-5.4	1
2.46465	12.2	16.4	-5.2	1
2.46470	12.1	16.4	-5.3	1
2.46475	12.1	16.4	-5.3	1
2.46480	12.2	16.4	-5.2	1
2.46485	12.4	16.4	-5.0	1
2.46490	12.3	16.4	-5.1	1
2.46495	12.4	16.4	-5.0	1
2.46500	12.7	16.4	-4.7	1
2.46505	12.6	16.4	-4.8	1
2.46510	12.6	16.4	-4.8	1
2.46515	12.8	16.4	-4.6	1
2.46520	12.7	16.4	-4.7	1
2.46525	12.6	16.4	-4.8	1
2.46530	12.7	16.4	-4.7	1
2.46535	12.7	16.4	-4.7	1
2.46540	12.7	16.4	-4.7	1
2.46545	12.7	16.4	-4.7	1
2.46550	12.7	16.4	-4.7	1



11Mbps CHANNEL 11 Processing Gain				
Freq.	Gp	(S/N)	Mj = J/S	Lsys
(GHz)	(dB)	(dB)	(dB)	(dB)
2.46555	12.8	16.4	-4.6	1
2.46560	13.0	16.4	-4.4	1
2.46565	13.2	16.4	-4.2	1
2.46570	13.2	16.4	-4.2	1
2.46575	13.4	16.4	-4.0	1
2.46580	13.3	16.4	-4.1	1
2.46585	13.4	16.4	-4.0	1
2.46590	13.3	16.4	-4.1	1
2.46595	13.3	16.4	-4.1	1
2.46600	13.4	16.4	-4.0	1
2.46605	13.5	16.4	-3.9	1
2.46610	13.4	16.4	-4.0	1
2.46615	13.6	16.4	-3.8	1
2.46620	13.5	16.4	-3.9	1
2.46625	13.8	16.4	-3.6	1
2.46630	13.8	16.4	-3.6	1
2.46635	14.0	16.4	-3.4	1
2.46640	14.0	16.4	-3.4	1
2.46645	14.1	16.4	-3.3	1
2.46650	14.2	16.4	-3.2	1
2.46655	14.4	16.4	-3.0	1
2.46660	14.2	16.4	-3.2	1
2.46665	14.4	16.4	-3.0	1
2.46670	14.4	16.4	-3.0	1
2.46675	14.4	16.4	-3.0	1
2.46680	14.4	16.4	-3.0	1
2.46685	14.6	16.4	-2.8	1
2.46690	14.6	16.4	-2.8	1
2.46695	14.9	16.4	-2.5	1
2.46700	14.9	16.4	-2.5	1