



Engineering Solutions & Electromagnetic Compatibility Services

**FCC Part 15.256 & Industry Canada RSS-Gen  
Certification Application Report**

<b>Test Lab:</b> Rhein Tech Laboratories, Inc.    Tel: 703-689-0368 360 Herndon Parkway            Fax: 703-689-2056 Suite 1400                            www.rheintech.com Herndon, VA 20170 E-Mail: atcbinfo@rheintech.com		<b>Applicant:</b> VEGA Grieshaber KG    Tel: 49-7836-50113 Am Hohenstein 113 D-77716 Schiltach Germany Contact: Juergen Motzer	
<b>FCC ID IC</b>	O6QPSWL61 3892A-PSWL61	<b>Test Report Date</b>	October 19, 2017
<b>Platform</b>	N/A	<b>RTL Work Order #</b>	2017178
<b>Model/HVIN</b>	PSWLS61	<b>RTL Quote #</b>	QRTL17-178A
<b>FCC Classification</b>	DXX – Part 15 Low Power Communication Device Transmitter		
<b>FCC Rule Part(s)/Guidance</b>	Part 15C, 15.256: Radio Frequency Devices  FCC 14-2: ET Docket No. 10-23: Amendment of Part 15 of the Commission's Rules To Establish Regulations for Level Probing Radars and Tank Level Probing Radars in the Frequency Bands 5.925-7.250 GHz, 24.05-29.00 GHz and 75-85 GHz  KDB 890966-D01 Meas Level Probing Radars V01 (April 4, 2014)		
<b>Test Procedure</b>	ANSI C63.10-2013: American National Standard of Procedures for Compliance Testing of Unlicensed Wireless Devices		
<b>Industry Canada</b>	RSS-Gen Issue 4: General Requirements for Compliance of Radio Apparatus RSS-211 Level Probing Radar Equipment		
<b>Digital Interface Information</b>	Digital Interface was found to be compliant		
<b>Frequency Range (GHz)</b>	<b>Output Power (mW)</b>	<b>Frequency Tolerance</b>	<b>Emission Designator</b>
26.0	0.003	N/A	N/A

I, the undersigned, hereby declare that the equipment tested and referenced in this report conforms to the identified standard(s) as described in this test report. No modifications were made to the equipment during testing in order to achieve compliance with these standards. Furthermore, there was no deviation from, additions to, or exclusions from, the applicable parts of FCC Part 2, FCC Part 15 Industry Canada RSS-Gen and ANSI C63.4.

Signature: 

Date: October 19, 2017

Typed/Printed Name: Desmond A. Fraser

Position: President

*This report may not be reproduced, except in full, without the written approval of Rhein Tech Laboratories, Inc. and VEGA Grieshaber KG. The test results relate only to the item(s) tested.*

*These tests are accredited and meet the requirements of ISO/IEC 17025 as verified by ANAB. Refer to certificate and scope of accreditation AT-1445.*

## Table of Contents

---

---

1	General Information.....	5
1.1	Scope.....	5
1.2	Test Facility.....	5
1.3	Modifications.....	5
2	Tested System Details.....	6
2.1	Test Distance.....	7
3	Modulated Bandwidth – ANSI C63.10 6.9, FCC 15.256(f)(1)RSS-Gen 6.6.....	8
3.1	Modulated Bandwidth Test Procedure – FCC 15.256(f)(1)RSS-Gen 6.6.....	8
3.2	Limits.....	8
3.3	Modulated Bandwidth Test Data.....	8
4	Radiated Emissions – ANSI C63.10 6.6, FCC 15.256(g)(3); RSS-Gen 6.12.....	10
4.1	Radiated Fundamental Emissions Test Procedure – FCC 15.256(g)(3); RSS-Gen 6.12.....	10
4.2	Radiated Fundamental Emissions Test Data.....	10
4.3	Radiated Emissions – ANSI C63.10 9, 15.256(h)(k); RSS-Gen 6.13.....	14
4.4	Radiated Emissions Harmonics/Spurious Test Procedure – FCC 15.256(h)(k); RSS-Gen 6.13.....	14
4.5	Radiated Emissions Harmonics/Spurious Test Data.....	14
4.6	Radiated Emissions Unintentional/Digital Test Data.....	20
5	Frequency Stability ANSI C63.10 6.8, FCC 15.256(f); RSS-Gen 6.11.....	22
5.1	Frequency Stability Test Procedure.....	22
5.2	FCC 15.256(f) Limit.....	22
5.3	Temperature-Voltage Frequency Stability Test Data.....	22
6	AC Conducted Emissions - FCC Rules and Regulations ANSI C63.10 6.2, Part 15.207; RSS-Gen	
7.2.4.....		25
6.1	Test Methodology for Conducted Line Emissions Measurements – Part 15.207; RSS-Gen 7.2.4..	25
	.....	25
6.2	Conducted Line Emissions Test Procedure.....	25
6.3	Conducted Line Emissions Test Data.....	26
7	Conclusion.....	27

**Table of Figures**

---



---

Figure 2-1: Configuration of Tested System .....	7
--	---

**Table of Plots**

---



---

Plot 3-1: 10 dB Modulated Bandwidth.....	9
Plot 4-1: Radiated Fundamental (EIRP in 1 MHz).....	12
Plot 4-2: Radiated Fundamental (EIRP in 50 MHz).....	13
Plot 4-3: Radiated Spurious Emissions (Second Harmonic).....	15
Plot 4-4: Radiated Spurious Emissions (Third Harmonic).....	16
Plot 4-5: Radiated Spurious Emissions (Fourth Harmonic).....	17
Plot 4-6: Radiated Spurious Emissions (50 GHz – 75 GHz).....	18
Plot 4-7: Radiated Spurious Emissions (75 GHz - 110 GHz).....	19
Plot 5-1: Frequency Stability – Standard Electronics.....	23
Plot 6-1: Conducted Emissions Transmit - Phase .....	26
Plot 6-2: Conducted Emissions Transmit – Neutral .....	27

**Table of Tables**

---



---

Table 2-1: Equipment under Test (EUT) .....	6
Table 3-1: 10 dB Modulated Bandwidth - 15.256(f)(1).....	8
Table 3-2: Modulated Bandwidth Test Equipment.....	9
Table 4-1: Radiated Fundamental Emissions (EIRP in 1 MHz, Average Detector).....	11
Table 4-2: Radiated Fundamental Emissions (EIRP in 50 MHz, Peak Detector).....	11
Table 4-3: Radiated Fundamental Emissions Test Equipment.....	13
Table 4-4: Radiated Second Harmonic Noise Floor Calculation .....	15
Table 4-5: Radiated Third Harmonic Noise Floor Calculation .....	16
Table 4-6: Radiated Fourth Harmonic Noise Floor Calculation.....	17
Table 4-7: Radiated Noise Floor Calculation (50 GHz – 75 GHz).....	18
Table 4-8: Radiated Noise Floor Calculation (75 GHz – 110 GHz).....	19
Table 4-9: Digital Radiated Emissions Test Data .....	20
Table 4-10: Radiated Emissions Test Equipment .....	21
Table 5-1: Temperature-Voltage Frequency Stability – Standard Electronics.....	22
Table 5-2: Frequency Stability Test Equipment.....	24
Table 6-1: Conducted Line Emissions Test Equipment .....	27

**Table of Appendixes**

---



---

Appendix A: RF Exposure Compliance FCC Rules and Regulations Part 1.1307, 1.1310, 2.1091, 2.1093 .....	28
Appendix B: Permissive Change Letter .....	30
Appendix C: Agency Authorization Letter.....	31
Appendix D: ISED Agency Authorization Letter .....	32
Appendix E: FCC & IC Confidentiality Request Letter.....	33
Appendix F: Canadian-based Representative .....	34
Appendix G: Manual.....	35
Appendix H: External Photographs.....	36
Appendix I: Antenna Information.....	37
Appendix J: Test Configuration Photographs .....	38
Appendix K: Antenna Information .....	40

---

### Table of Photographs

---

Photograph 1:	PSWLS61 with 82mm Encapsulated Plastic Horn Antenna .....	6
Photograph 2:	Radiated Emissions – Rear View .....	38
Photograph 3:	AC Conducted Emissions - Rear View .....	39

## **1 General Information**

### **1.1 Scope**

This measurement report is prepared on behalf of VEGA Grieshaber KG in accordance with the applicable Federal Communications Commission and Industry Canada rules and regulations.

The Equipment Under Test (EUT) was the Level Probing Radar Model/HVIN PSWLS61, Level Probing Radar, FCC ID: O6QPSWL61, IC: 3892A-PSWL61 tested with one antenna.

### **1.2 Test Facility**

The open area test site and conducted measurement facility used to collect the radiated data is located on the parking lot of Rhein Tech Laboratories, Inc., 360 Herndon Parkway, Suite 1400, Herndon, Virginia 20170. This site has been fully described in a report submitted to and approved by the Federal Communications Commission to perform AC line conducted and radiated emissions testing.

### **1.3 Modifications**

None.

## 2 Tested System Details

The test sample was received on October 11, 2017. Listed below are the identifiers and descriptions of all equipment, cables, and internal devices used with the EUT for this testing, as applicable.

**Table 2-1: Equipment under Test (EUT)**

Part	Manufacturer	Model (HVIN)	Serial Number	FCC ID	Cable Type	RTL Bar Code
PSWLS61.XXX	VEGA Grieshaber KG	PSWLS61	37464424	O6QPSWL61	N/A	22595
82mm Encapsulated Plastic Horn Antenna (25.07 dBi)	VEGA Grieshaber KG	N/A	N/A	N/A	N/A	N/A
DC Power Supply	Hewlett Packard	6024A	1912A003 31	N/A	1m un-shielded	901635

**Photograph 1: PSWLS61 with 82mm Encapsulated Plastic Horn Antenna**



**Figure 2-1: Configuration of Tested System**

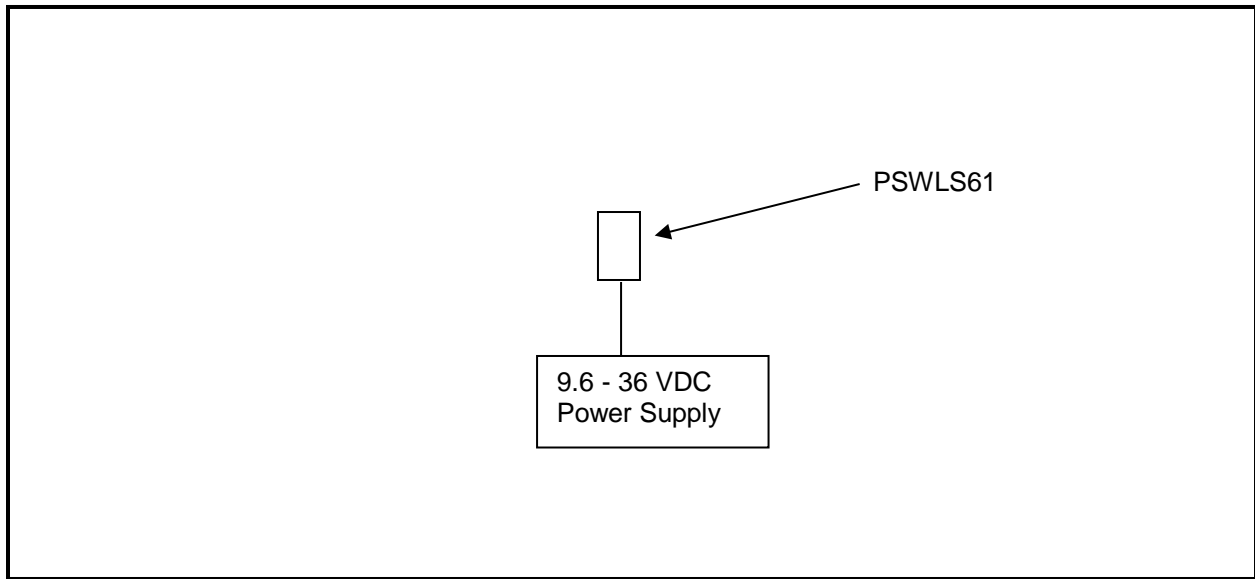

## 2.1 Test Distance

The final radiated emissions tests were performed at a 3-meter horizontal distance from the edge of the radar to the test antenna. The EUT was also investigated at closer test distances in order to discern any emissions.

### 3 Modulated Bandwidth – ANSI C63.10 6.9, FCC 15.256(f)(1)RSS-Gen 6.6

#### 3.1 Modulated Bandwidth Test Procedure – FCC 15.256(f)(1)RSS-Gen 6.6

The minimum 10 dB bandwidth was measured using a 50-ohm spectrum analyzer with the resolution bandwidth set at 1 MHz and the video bandwidth set at 3 MHz. The spectrum analyzer's display markers were set to -10 dB using max hold until the spectrum was filled and a plot taken.

#### 3.2 Limits

(f) The fundamental bandwidth of an LPR emission is defined as the width of the signal between two points, one below and one above the center frequency, outside of which all emissions are attenuated by at least 10 dB relative to the maximum transmitter output power when measured in an equivalent resolution bandwidth.

(1) The minimum fundamental emission bandwidth shall be 50 MHz for LPR operation under the provisions of this section.

#### 3.3 Modulated Bandwidth Test Data

Table 3-1: 10 dB Modulated Bandwidth - 15.256(f)(1)

Part	10 dB Bandwidth (MHz)	Minimum Limit (MHz)	Margin (MHz)
PSWLS61.XXX	1785	50	-1735



**Plot 3-1: 10 dB Modulated Bandwidth**

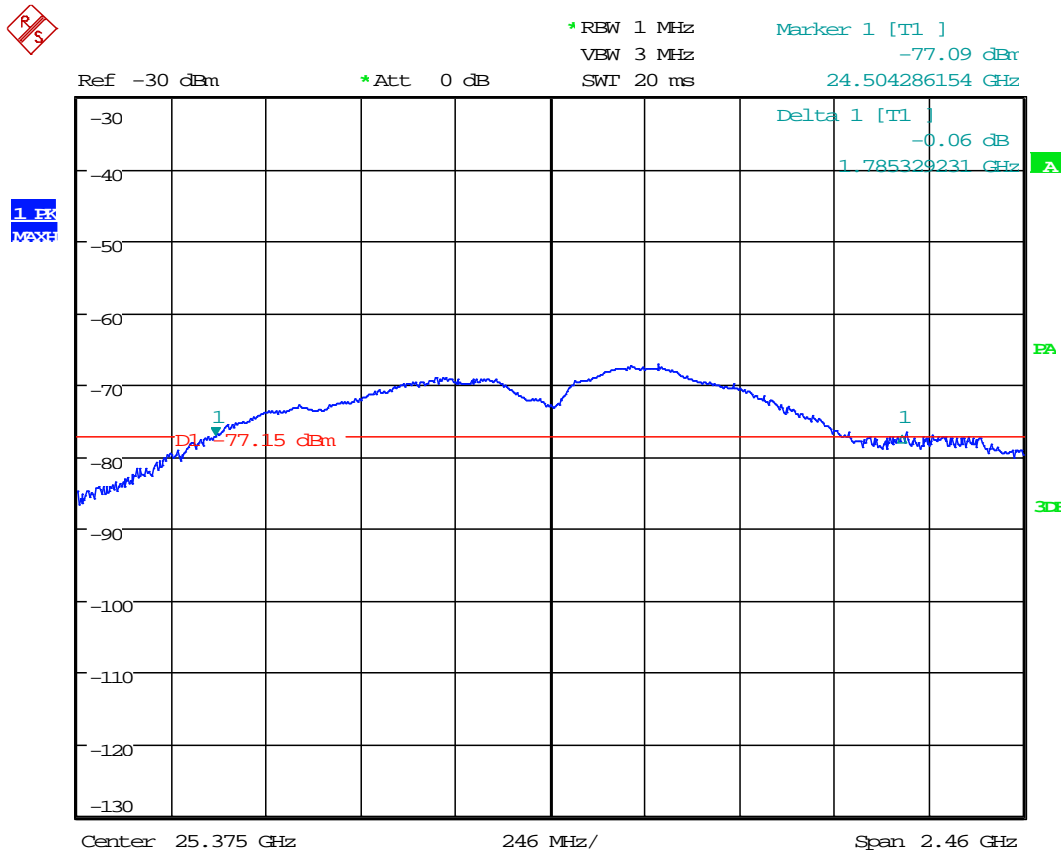

Date: 12.OCT.2017 07:49:50

**Table 3-2: Modulated Bandwidth Test Equipment**

RTL Asset #	Manufacturer	Model	Part Type	Serial Number	Calibration Due Date
901581	Rohde & Schwarz	FSU	Spectrum Analyzer	1166.1660.50	3/22/18

**Test Personnel:**

  
 Daniel W. Baltzell  
 Test Engineer
 

 Signature
 

 October 12, 2017  
 Date of Test

#### 4 Radiated Emissions – ANSI C63.10 6.6, FCC 15.256(g)(3); RSS-Gen 6.12

##### 4.1 Radiated Fundamental Emissions Test Procedure – FCC 15.256(g)(3); RSS-Gen 6.12

Radiated emissions of the fundamental were tested by “bore sighting” the main-beam emissions to produce the maximum realizable antenna coupling. The EUT was also checked in all three orthogonal planes. Measurement was based on an average detector for -14 dBm/1 MHz power density limit and peak detector for 26 dBm/50 MHz limit. Limits are -14 dBm/MHz and 26 dBm/50 MHz bandwidth (corrected to 20 MHz). Since these limits are power density, no pulse desensitization correction factor is required. Both were also measured finding the maximum amplitude at 3 meters and switching from 1 MHz to 20 MHz resolution bandwidths.

Limits: The EIRP limits for LPR operations in the bands authorized by this rule section are provided in the following table. These emission limits are based on bore sight measurements (i.e., measurements performed within the main beam of the LPR antenna).

Frequency Band of Operation (GHz)	Average Emission Limit (EIRP in dBm measured in 1 MHz)	Peak Emission Limit (EIRP in dBm measured in 50 MHz)
5.925-7.250	-33	7
24.05-29.00	-14	26
75-85	-3	34

##### 4.2 Radiated Fundamental Emissions Test Data

Radiated measurements are converted from dBuV/m to dBm using the following equation from KDB 890966 6 b:

For radiated emission measurements

$$\text{EIRP (dBm)} = \text{field strength (dB}\mu\text{V/m)} - 104.8 + 20 \text{ Log D}$$

where:

D is the measurement distance. Measurements were at 1 meter.

All power averaging (RMS) emission levels are to be measured utilizing a 1 MHz resolution bandwidth with a one millisecond dwell time over each 1 MHz segment. The frequency span of the analyzer should equal the number of sampling bins times 1 MHz and the sweep rate of the analyzer should equal the number of sampling bins times one millisecond. The video bandwidth of the measurement instrument shall not be less than the resolution bandwidth and trace averaging shall not be employed. The RMS average emission measurement is to be repeated over multiple sweeps with the analyzer set for maximum hold until the amplitude stabilizes. The peak emission measurement is to be repeated over multiple sweeps with the analyzer set for maximum hold until the amplitude stabilizes.

NOTE: Number of sampling BINS used = 1501

For ISSED, the standard ETSI EN 302 729 was used to test the EUT.

**Table 4-1: Radiated Fundamental Emissions (EIRP in 1 MHz, Average Detector)**

Frequency (GHz)	Average Spectrum Analyzer Level (dBuV) (1m)	Antenna Correction Factor (dB/m)	Corrected Average Measurement (dBuV/m) (1m)	Converted to dBm	Limit (dBm)	Margin (dB)
25.501	26.3	47.4	73.7	-31.1	-14.0	-17.1

**Table 4-2: Radiated Fundamental Emissions (EIRP in 50 MHz, Peak Detector)**

Frequency (GHz)	Peak EIRP Measured (dBuV) (1m)	Site Correction Factor (dB/m) + 8 dB*	Corrected Peak Measurement (dBuV/m) (1m)	Converted to dBm	Limit (dBm)	Margin (dB)
25.297	42.7	55.4	98.1	-6.7	26.0	-32.7

\*NOTE: Per FCC 15.256(g)(2)(ii): The Rhode & Schwarz FSU 50 spectrum analyzer used a maximum video bandwidth resolution of 20 MHz less than the required 50 MHz RBW, a lower RBW of 20 MHz was adjusted to the limit using  $20 \log(\text{RBW}/50)$  dB. The resolution bandwidth used is 20 MHz, therefore  $20 \log(20/50) = 8$  dB increase of the fundamental to adjust towards the 50 MHz EIRP BW requirement.

**Plot 4-1: Radiated Fundamental (EIRP in 1 MHz)**

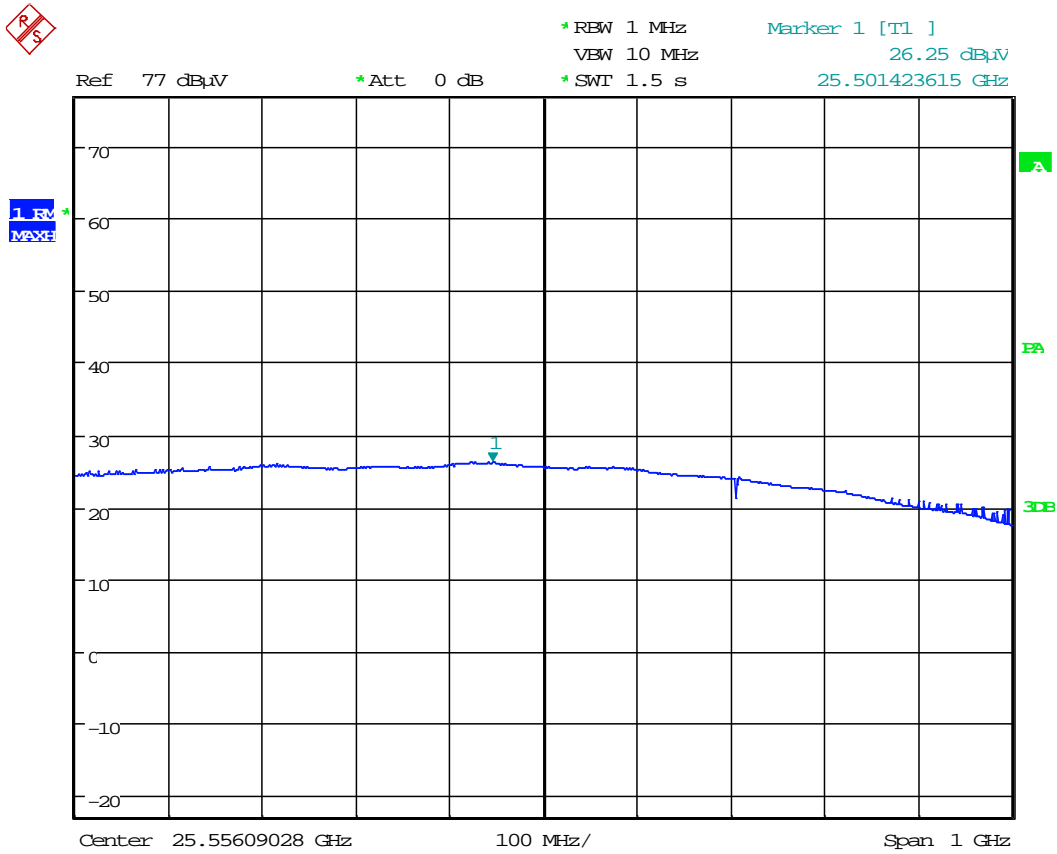

Date: 16.OCT.2017 14:18:14

**Plot 4-2: Radiated Fundamental (EIRP in 50 MHz)**

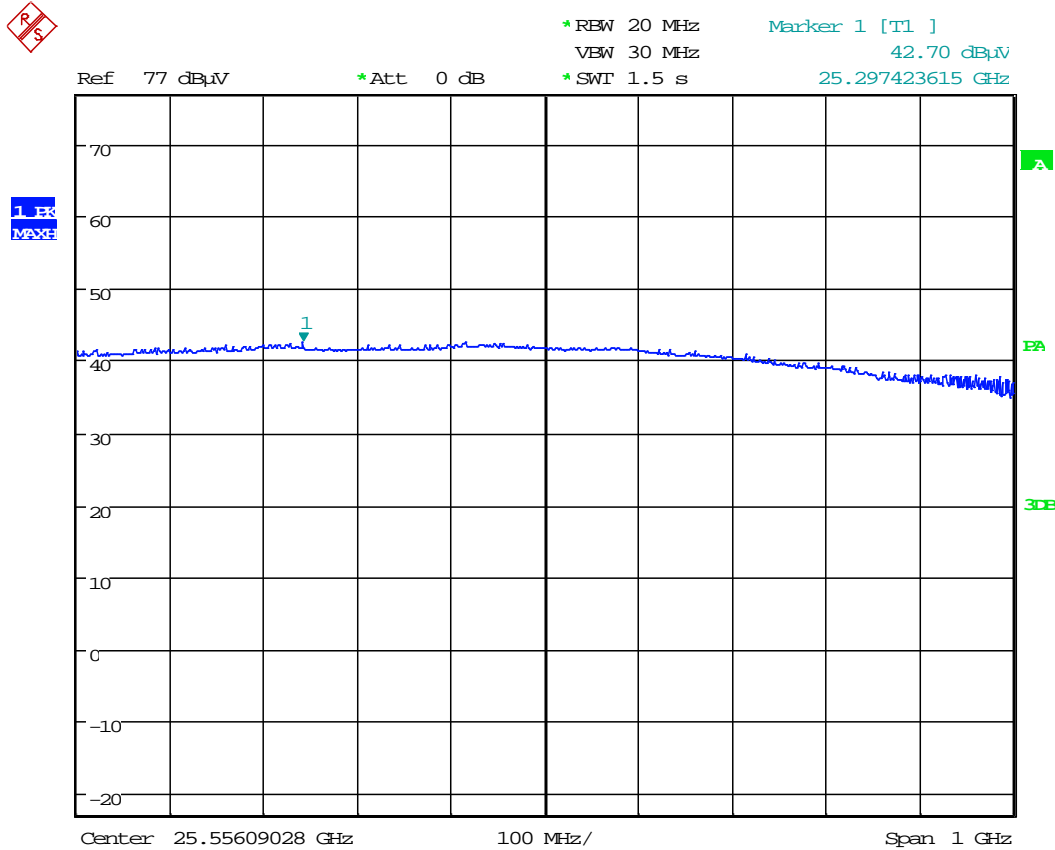

Date: 16.OCT.2017 14:21:25

**Table 4-3: Radiated Fundamental Emissions Test Equipment**

RTL Asset #	Manufacturer	Model	Part Type	Serial Number	Calibration Due Date
901581	Rohde & Schwarz	FSU	Spectrum Analyzer	1166.1660.50	3/22/18
901281	EMCO	3160-09	Horn Antenna (18-26.5 GHz)	960281-003	4/14/18
900874	Continental Microwave & Tool	RA42-K-F- 4B-C	Waveguide (18-26.5 GHz)	990706-002	Not Required

**Test Personnel:**

Dan Baltzell Test Engineer	 Signature	October 16, 2017 Date of Test
-------------------------------	--	----------------------------------

#### **4.3 Radiated Emissions – ANSI C63.10 9, 15.256(h)(k); RSS-Gen 6.13**

#### **4.4 Radiated Emissions Harmonics/Spurious Test Procedure – FCC 15.256(h)(k); RSS-Gen 6.13**

No radiated emissions of the harmonics were found to be measured; noise floor data was taken and corrected to three meters. The EUT was checked in the three orthogonal planes with the receive antenna in both polarities. A resolution bandwidth of 100 kHz was used for frequencies less than 1000 MHz, and a resolution bandwidth of 1 MHz was used for frequencies greater than or equal to 1000 MHz.

Limit: Unwanted Emissions from LPR devices shall not exceed the general emission limit in §15.209 of this chapter.

#### **4.5 Radiated Emissions Harmonics/Spurious Test Data**

No radiated harmonics were found to be measured or unintentional emissions above 1 GHz. The following plots are provided as reference.

The plots were taken with the measuring antenna abutted to the transmit antenna, showing no indication or detectable frequencies, this reduces signal to noise ratio as a distance of 1 mm corrected to 3 m is  $20 \log(0.001/3) = -69.5$  dB. The emissions from the EUT were investigated at 0.1 m and 3 m to ensure no indication of detectable emissions.

**Plot 4-3: Radiated Spurious Emissions (Second Harmonic)**

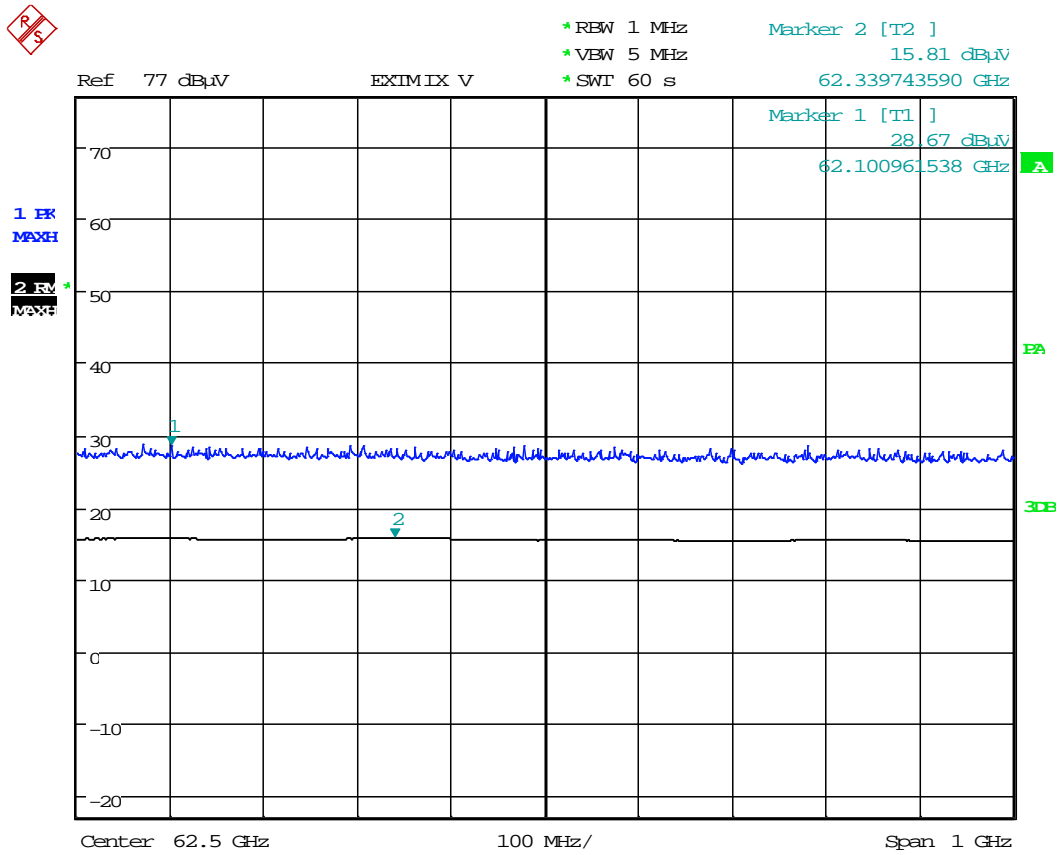

Date: 19.OCT.2017 11:08:44

**Table 4-4: Radiated Second Harmonic Noise Floor Calculation**

Frequency (GHz)	EIRP Measured (dBuV)	Test Antenna Gain (dBi)	Correction from .001m to 3m (dB)	Corrected Measurement (dBuV/m)	FCC Limit (dBuV)	Margin (dB)	Corrected Measurement (dBm/MHz)	Limit (dBm/MHz)	Margin (dB)	Peak/Average
62.3	20.7	43.1	-69.5	-5.7	74	79.7				Peak
62.1	15.0	43.1	-69.5	-11.4	54	65.4				Average
62.1	15.0	43.1	-69.5	-11.4			-106.6	-41.3	65	Average

**Plot 4-4: Radiated Spurious Emissions (Third Harmonic)**

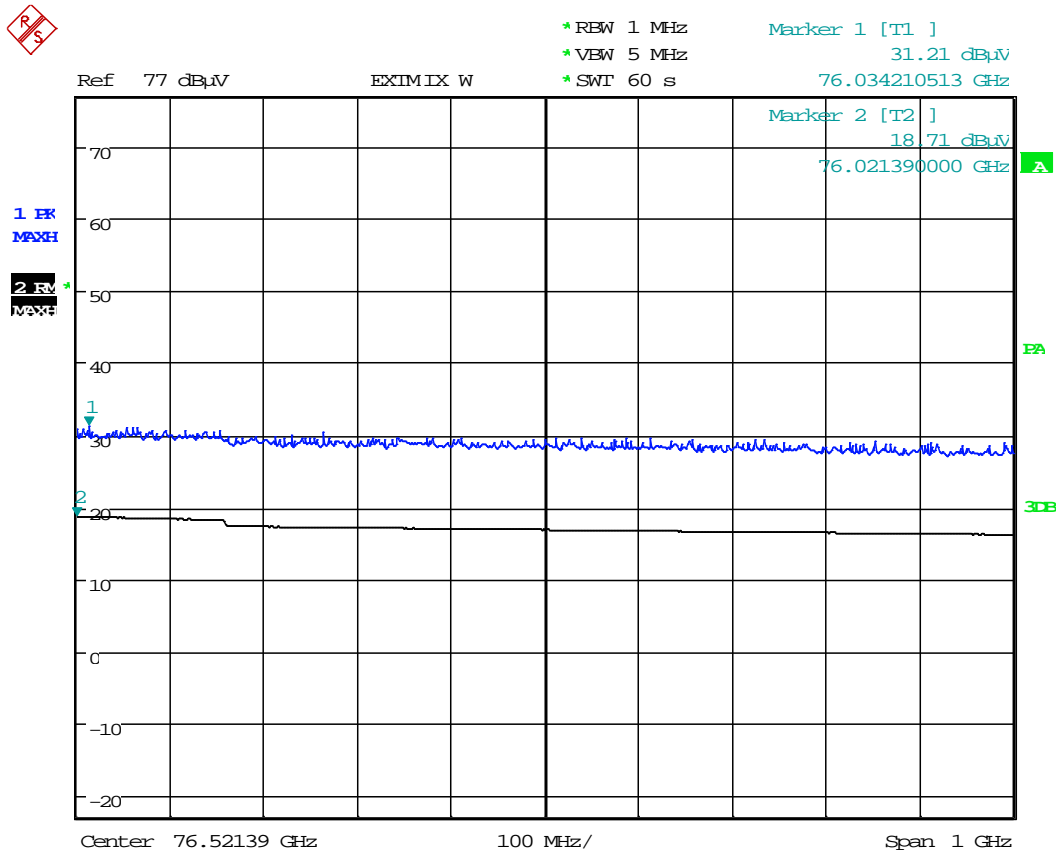

Date: 19.OCT.2017 12:56:57

**Table 4-5: Radiated Third Harmonic Noise Floor Calculation**

Frequency (GHz)	EIRP Measured (dBuV)	Test Antenna Gain (dBi)	Correction from .001m to 3m (dB)	Corrected Measurement (dBuV/m)	FCC Limit (dBuV)	Margin (dB)	Corrected Measurement (dBm/MHz)	Limit (dBm/MHz)	Margin (dB)	Peak/Average
76.0	31.2	45.3	-69.5	7.0	74.0	66.0				Peak
76.0	18.7	45.3	-69.5	-5.5	54.0	59.5				Average
76.0	18.7	45.3	-69.5	-5.5			-100.7	-41.3	59.4	Average



**Plot 4-5: Radiated Spurious Emissions (Fourth Harmonic)**

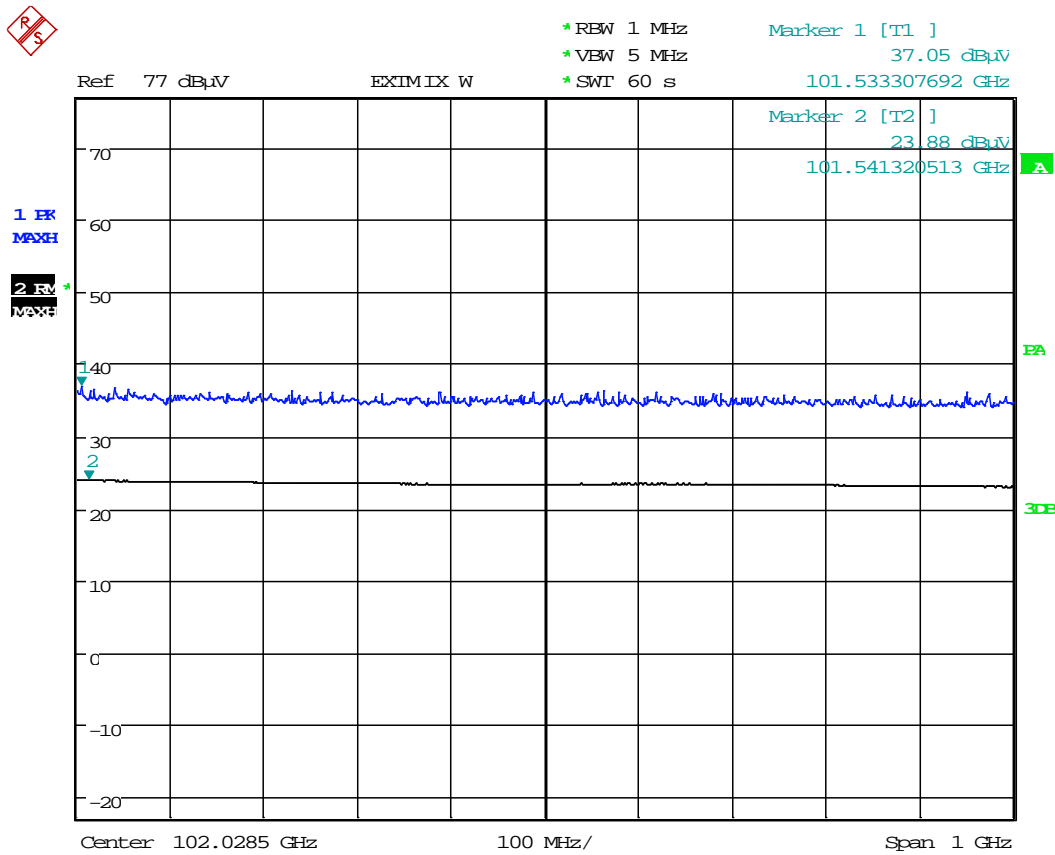

Date: 19.OCT.2017 13:03:13

**Table 4-6: Radiated Fourth Harmonic Noise Floor Calculation**

Frequency (GHz)	EIRP Measured (dBuV)	Test Antenna Gain (dBi)	Correction from .001m to 3m (dB)	Corrected Measurement (dBuV/m)	FCC Limit (dBuV)	Margin (dB)	Corrected Measurement (dBm/MHz)	Limit (dBm/MHz)	Margin (dB)	Peak/Average
101.5	37.1	46.9	-69.5	14.5	74	59.5				Peak
101.5	23.9	46.9	-69.5	1.3	54	52.7				Average
101.5	23.9	46.9	-69.5	1.3			-93.9	-41.3	52.6	Average

**Plot 4-6: Radiated Spurious Emissions (50 GHz – 75 GHz)**

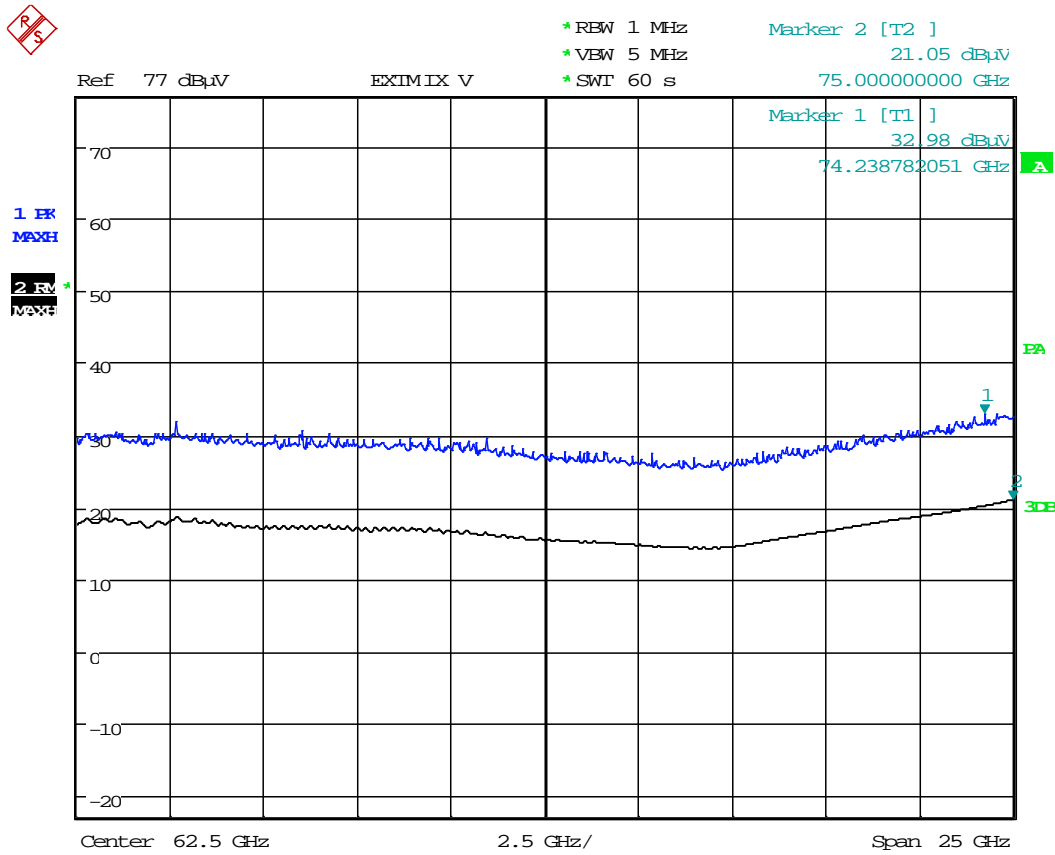

Date: 19.OCT.2017 13:11:18

**Table 4-7: Radiated Noise Floor Calculation (50 GHz – 75 GHz)**

Frequency (GHz)	EIRP Measured (dBuV)	Test Antenna Gain (dBi)	Correction from .001m to 3m (dB)	Corrected Measurement (dBuV/m)	FCC Limit (dBuV)	Margin (dB)	Corrected Measurement (dBm/MHz)	Limit (dBm/MHz)	Margin (dB)	Peak/Average
75.0 (worst case)	33	44.2	-69.5	7.7	74.0	66.3				Peak
74.2 (worst case)	21.1	44.2	-69.5	4.2	54.0	49.8				Average
74.2 (worst case)	21.1	44.2	-69.5	4.2			-91.0	-41.3	49.7	Average

**Plot 4-7: Radiated Spurious Emissions (75 GHz - 110 GHz)**

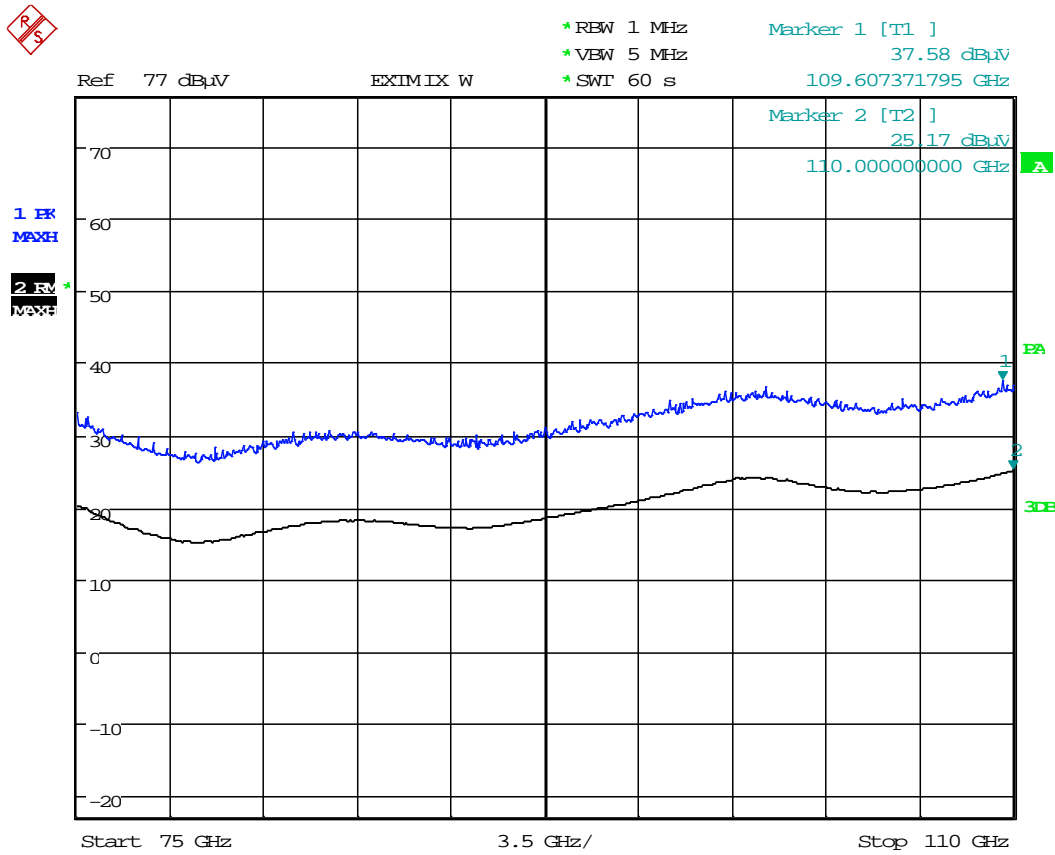

Date: 19.OCT.2017 13:05:15

**Table 4-8: Radiated Noise Floor Calculation (75 GHz – 110 GHz)**

Frequency (GHz)	EIRP Measured (dBuV)	Test Antenna Gain (dBi)	Correction from .001m to 3m (dB)	Corrected Measurement (dBuV/m)	FCC Limit (dBuV)	Margin (dB)	Corrected Measurement (dBm/MHz)	Limit (dBm/MHz)	Margin (dB)	Peak/Average
109.6	23.9	47.6	-69.5	2.0	74.0	72.0				Peak
110.0	25.2	47.6	-69.5	3.3	54.0	50.7				Average
110.0	25.2	47.6	-69.5	3.3			-91.9	-41.3	62.4	Average

#### 4.6 Radiated Emissions Unintentional/Digital Test Data

**Table 4-9: Digital Radiated Emissions Test Data**

Frequency (MHz)	Spectrum Analyzer Level (dBuV)	Site Correction (dB/m)	Corrected Analyzer (dBuV/m)	Limit (dBuV/m)	Margin (dB)
330.057	9.2	15.5	24.7	46.0	-21.3
357.976	3.5	17.6	21.1	46.0	-24.9
383.063	5.8	18.4	24.2	46.0	-21.8
390.195	5.5	19.4	24.9	46.0	-21.1
397.426	4.9	19.4	24.3	46.0	-21.7
418.769	2.2	19.5	21.7	46.0	-24.3
425.992	2.6	19.5	22.1	46.0	-23.9
433.152	4.4	19.5	23.9	46.0	-22.1
440.312	4.8	19.5	24.3	46.0	-21.7
576.343	0.6	22.2	22.8	46.0	-23.2
640.778	7.5	23.5	31.0	46.0	-15.0
647.938	7.6	23.9	31.5	46.0	-14.5
805.448	-0.6	25.5	24.9	46.0	-21.1

Unwanted emissions were investigated (other than harmonics) as required by 15.33(a)(2).

“If the intentional radiator operates at or above 10 GHz and below 30 GHz: to the fifth harmonic of the highest fundamental frequency, or to 100 GHz, whichever is lower.”

**Table 4-10: Radiated Emissions Test Equipment**

RTL Asset #	Manufacturer	Model	Part Type	Serial Number	Calibration Due Date
901592	Insulated Wire Inc.	KPS-1503-3600-KPR	SMK RF Cables 20'	NA	8/21/18
901705	Insulated Wire Inc.	KPS-1503-360-KPR	SMK RF Cables 36"	NA	5/31/18
901698	Insulated Wire Inc.	KPS-1503-360-KPR	SMK RF Cables 36"	NA	9/23/18
901639	Wiltron	35WR19F	Waveguide (40-50 GHz)	N/A	6/18/18
901640	Rohde & Schwarz	FS-Z110	Mixer (75 - 110 GHz)	100010	5/24/18
901581	Rohde & Schwarz	FSU	Spectrum Analyzer	1166.1660.50	3/22/18
901586	Rohde & Schwarz	FS-Z75	Harmonic Mixer (50 - 75 GHz)	100098	1/23/18
901256	ATM	19-443-6R	Horn antenna (40-60 GHz, WR-19)	8041704-01	1/23/18
901303	EMCO	3160-10	Horn Antenna (26.5-40.0 GHz) WR-28	960452-007	6/19/18
901161	Advanced Technical Materials	28-25K-6	Waveguide (26.5 - 40 GHz)	B082304	Not required
900711	ATM	10-443-6R	Horn Antenna (75 - 110 GHz)	8051905-1	12/5/17
900712	ATM	15-443-6R	Horn Antenna (50 - 75 GHz)	8051805-1	3/16/18
900791	Chase	CBL6111B	Bilog antenna (30 MHz - 2000 MHz)	N/A	10/4/20
900772	EMCO	3161-02	Horn Antenna (2 - 4 GHz)	9804-1044	4/9/18
900321	EMCO	3161-03	Horn Antenna (4.0 - 8.2 GHz)	9508-1020	4/9/18
900323	EMCO	3160-07	Horn Antenna (8.2 - 12.4 GHz)	9605-1054	4/9/18
900356	EMCO	3160-08	Horn Antenna (12.4 - 18 GHz)	9607-1044	4/9/18
901218	EMCO	3160-09	Horn Antenna (18 - 26.5 GHz)	960281-003	4/19/18
900874	Continental Microwave & Tool	RA42-K-F-4B-C	18-26.5 GHz Waveguide	990706-002	Not Required

**Test Personnel:**

Daniel W. Baltzell  
 Test Engineer

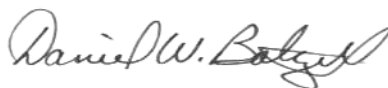

Signature

October 17-19, 2017  
 Dates of Test

## 5 Frequency Stability ANSI C63.10 6.8, FCC 15.256(f); RSS-Gen 6.11

### 5.1 Frequency Stability Test Procedure

The carrier frequency stability is the ability of the transmitter to maintain an assigned carrier frequency.

The EUT was evaluated over the temperature range -30°C to +50°C.

The temperature was initially set to -30°C and a 1-hour period was observed for stabilization of the EUT. The frequency stability was measured within one minute after application of primary power to the transmitter. The temperature was raised at intervals of 10 degrees centigrade through the range. A ½-hour period was observed to stabilize the EUT at each measurement step and the frequency stability was measured within one minute after application of primary power to the transmitter. Additionally, the power supply voltage of the EUT was varied +/-15% nominal input voltage, +15% of minimum voltage and -15% of maximum voltage.

### 5.2 FCC 15.256(f) Limit

LPR devices operating under this section must confine their fundamental emission bandwidth within the 5.925-7.250 GHz, 24.05-29.00 GHz, and 75-85 GHz bands under all conditions of operation.

### 5.3 Temperature-Voltage Frequency Stability Test Data

Table 5-1: Temperature-Voltage Frequency Stability – Standard Electronics

Temp (°C)	+/- 15% VDC						
	9.6 (Min.)	11.04 (Min. + 15%)	19.38 (-15%)	22.8 (Mid.)	26.22 (+ 15%)	30.6 (Max. - 15%)	36 (Max.)
-30	25.172740283	25.172750433	25.172763973	25.172760593	25.172770743	25.172747053	25.172753823
-20	25.172780893	25.172828283	25.172814743	25.172780893	25.172848593	25.172787663	25.172807973
-10	25.172838433	25.172838433	25.172831663	25.172855353	25.172889203	25.172885823	25.172865513
0	25.172845203	25.172851973	25.172804593	25.172814743	25.172811353	25.172835053	25.172848593
10	25.172804593	25.172814743	25.172841823	25.172807973	25.172801203	25.172804593	25.172818123
20	25.172767353	25.172767353	25.172736893	25.172753823	25.172750433	25.172794433	25.172747053
30	25.172787663	25.172757203	25.172794433	25.172733513	25.172750433	25.172726743	25.172777513
40	25.172703053	25.172699663	25.172723353	25.172716593	25.172692893	25.172713203	25.172713203
50	25.172625203	25.172675973	25.172648893	25.172659053	25.172652283	25.172631973	25.172635353

**Plot 5-1: Frequency Stability – Standard Electronics**

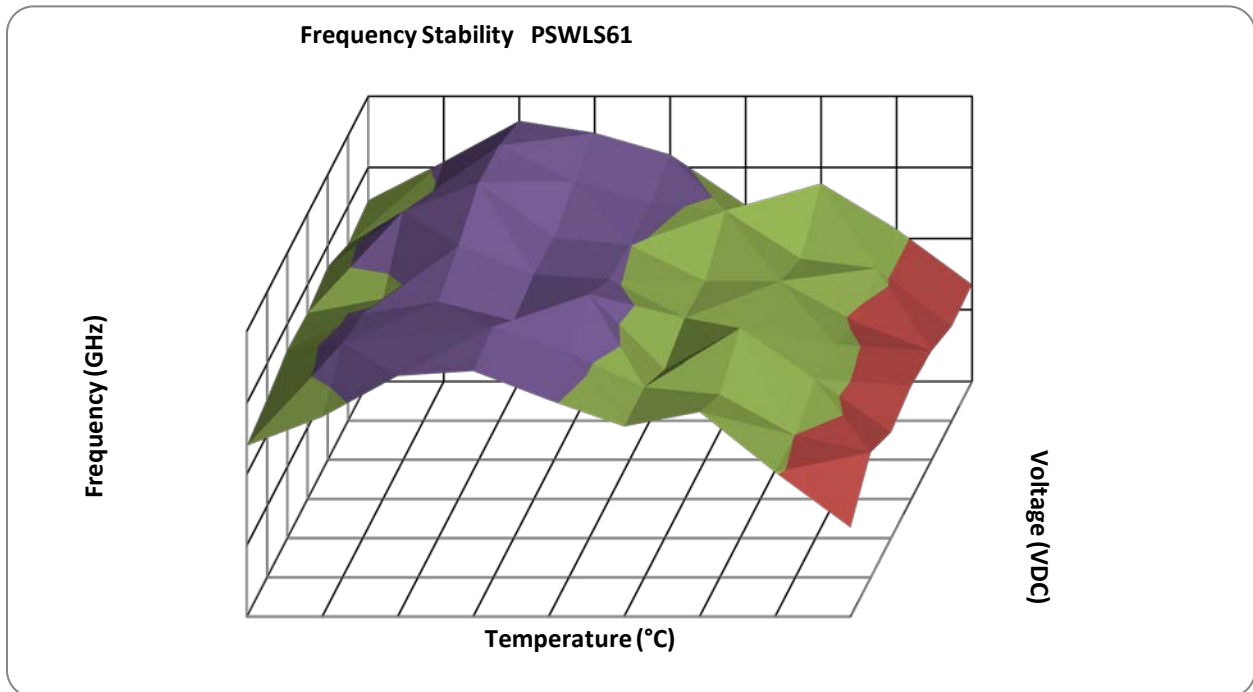

To determine if the bandwidth of the signal remains within the band 24.05 GHz – 29 GHz, the highest frequency generated, 25.172889203 GHz (at -10°C, 26.22 VDC), and the lowest frequency generated, 25.172625203 GHz (at 50°C, 9.6 VDC), are compared to the measured bandwidth, 1785.329231 MHz. Half the bandwidth, to determine the edge of the frequency, is subtracted from the lowest frequency generated, and added to the highest frequency generated.

$$\frac{1}{2} \text{ bandwidth} = 1785.329231 \text{ MHz} / 2 = 892.6646155 \text{ MHz.}$$

Lowest frequency generated 25.172625203 GHz - 892.6646155 MHz = 24.279960587 GHz,  
which is within the band 24.05 - 29 GHz (passing with margin 24.05 - 24.279961 = -229.961 MHz).

Highest frequency generated 25.172625203 GHz + 892.6646155 MHz = 26.065553818 GHz,  
which is within the band 24.05 - 29 GHz (passing with margin 24.05 - 26.065554 = -2934.446 MHz).

**Results: The EUT is compliant.**

**Table 5-2: Frequency Stability Test Equipment**

RTL Asset #	Manufacturer	Model	Part Type	Serial Number	Calibration Due Date
900946	Tenney Engineering, Inc.	TH65	Temperature Chamber with Humidity	11380	3/26/18
901672	Rohde & Schwarz	FSEM30	Spectrum Analyzer	FSEM30	4/17/19
901593	Insulated Wire Inc.	KPS-1503-360-KPR	SMK RF Cables 36"	NA	8/18/18
901350	Meterman	33XR	Multimeter	040402802	4/26/19

**Test Personnel:**

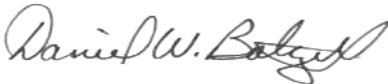
		
Daniel Baltzell Test Engineer	Signature	October 12, 2017 Date of Tests



## **6 AC Conducted Emissions - FCC Rules and Regulations ANSI C63.10 6.2, Part 15.207; RSS-Gen 7.2.4**

### **6.1 Test Methodology for Conducted Line Emissions Measurements – Part 15.207; RSS-Gen 7.2.4**

The power line conducted emission measurements were performed in a Series 81 type shielded enclosure manufactured by Rayproof. The EUT was placed on a wooden table. Power was fed to the EUT through a 50-ohm/50  $\mu$ Henry Line Impedance Stabilization Network (LISN). The EUT LISN was fed power through an AC filter box on the outside of the shielded enclosure. The filter box and EUT LISN housing are bonded to the ground plane of the shielded enclosure. A second LISN, the peripheral LISN, provides isolation for the EUT's auxiliary equipment. This peripheral LISN was also fed AC power.

The spectrum analyzer was connected to the AC line through an isolation transformer. The 50-ohm output of the EUT LISN was connected to the spectrum analyzer input through a Solar 100 kHz high-pass filter. The filter is used to prevent overload of the spectrum analyzer from noise below 100 kHz. Conducted emission levels were measured on each current-carrying line with the spectrum analyzer operating in the CISPR quasi-peak mode (or peak mode if applicable). The analyzer's 6 dB bandwidth was set to 9 kHz. Video filter less than 10 times the resolution bandwidth is not used. Average measurements are performed in linear mode using a 10 kHz resolution bandwidth, a 1 Hz video bandwidth, by increasing the sweep time in order to obtain a calibrated measurement. The emission spectrum was scanned from 150 kHz to 30 MHz. The highest emission amplitudes relative to the appropriate limits were measured and have been recorded.

### **6.2 Conducted Line Emissions Test Procedure**

Conducted emissions were performed on the EUT using an off-the-shelf power supply. The general conducted limit under Part 15.207 was applied. The emissions were scanned between 150 kHz to 30 MHz on the neutral and phase conductors.

### 6.3 Conducted Line Emissions Test Data

Plot 6-1: Conducted Emissions Transmit - Phase

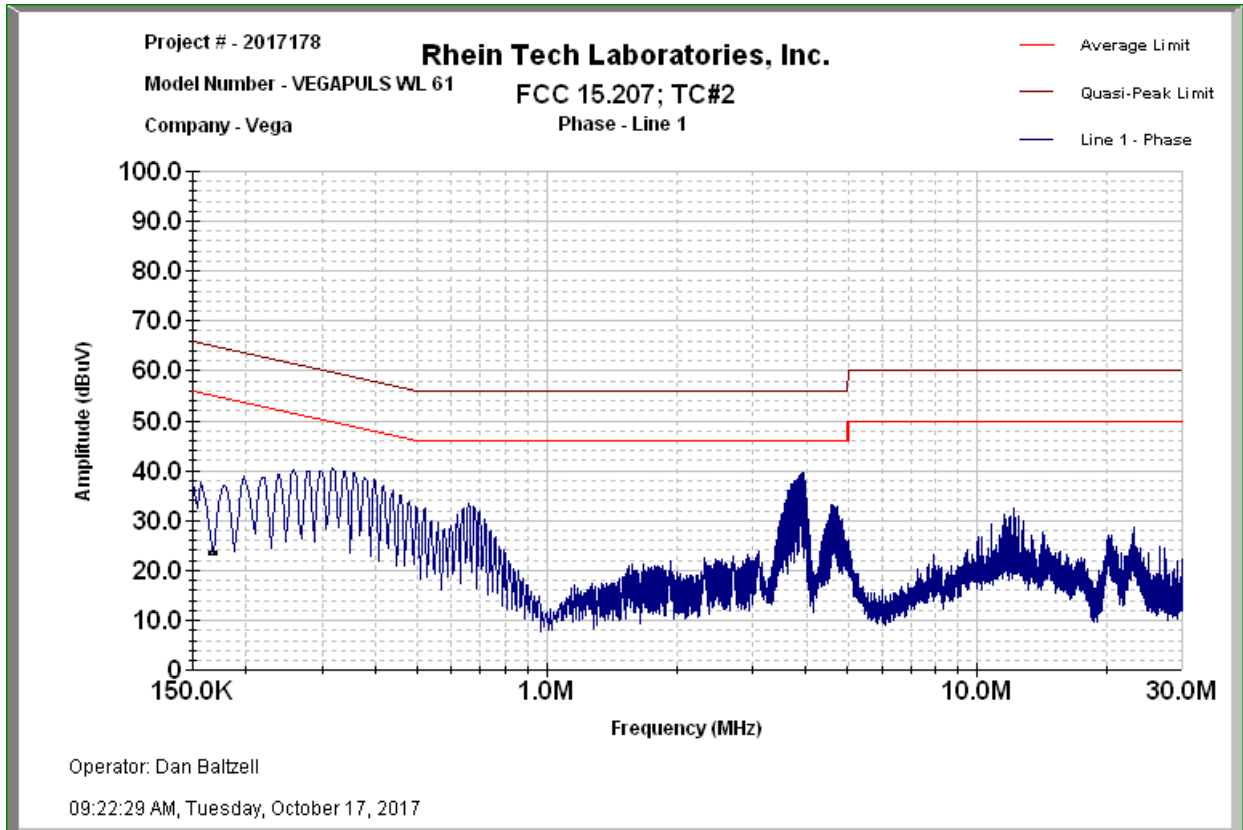

**Plot 6-2: Conducted Emissions Transmit – Neutral**

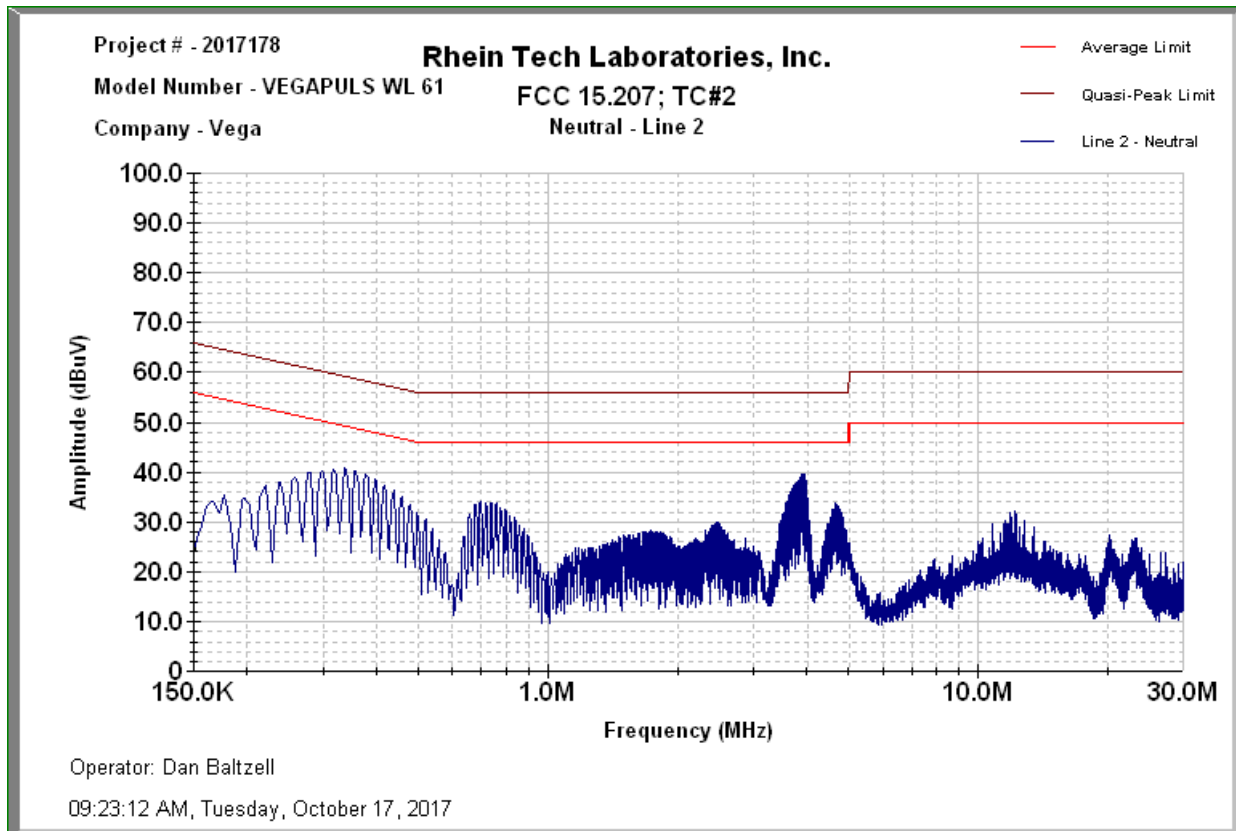

**Table 6-1: Conducted Line Emissions Test Equipment**

RTL Asset #	Manufacturer	Model	Part Type	Serial Number	Calibration Due Date
901581	Rohde & Schwarz	FSU	Spectrum Analyzer	1166.1660.50	3/22/18
901084	AFJ International	LS16	16A LISN	16010020082	3/24/18
N/A	Rhein Tech Laboratories, Inc.	Automated Emissions Tester	Emissions Testing Software Rev. 14.0.2	N/A	N/A

**Test Personnel:**

Daniel W. Baltzell Test Engineer	 Signature	October 17, 2017 Date of Test
-------------------------------------	--	----------------------------------

**7 Conclusion**

The data in this measurement report shows that the Vega Grieshaber KG Model/HVIN PSWLS61, FCC ID: O6QPSWL61, IC:3892A-PSWL61, complies with the applicable requirements of Parts 2 and 15 of the FCC rules and regulations and Industry Canada RSS-Gen.