



Engineering Solutions & Electromagnetic Compatibility Services

VEGA Grieshaber KG
Am Hohenstein 113
77761 Schiltach
Germany

MODEL: PS60S
FCC ID: O6QPS60XS2
IC: 3892A-PS60XS2

October 30, 2016

Standards Referenced for this Report	
Part 2: October 2015	Frequency Allocations and Radio Treaty Matters; General Rules and Regulations
Part 15: October 2015	Radio Frequency Devices - §15.209: Radiated Emissions Limits
ANSI C63.10-2013:	American National Standard of Procedures for Compliance Testing of Unlicensed Wireless Devices.
RSS-Gen	General Requirements for Compliance of Radio Apparatus
RSS-211	Level Probing Radar Equipment

Frequency Range	Output Power (W) Conducted	Frequency Tolerance (ppm)	Emission Designator
26 GHz	0.000035	N/A	N/A

We, the undersigned, hereby declare that the equipment tested and referenced in this report conforms to the identified standard(s) as described in this attached test record. No modifications were made to the equipment during testing in order to achieve compliance with these standards. Furthermore, there was no deviation from, additions to, or exclusions from, the above standards for Certification methodology.

Signature: 

Date: October 30, 2016

Typed/Printed Name: Desmond Fraser

Position: President

Signature: 

Date: October 30, 2016

Typed/Printed Name: Dan Baltzell

Position: Test Engineer

Document Number: 2015083-1

This report may not be reproduced, except in full, without the written approval of Rhein Tech Laboratories, Inc. and VEGA Grieshaber KG. The test results relate only to the item(s) tested.

These test(s) are accredited under Rhein Tech Laboratories, Inc. ISO/IEC 17025 accreditation issued by the ANSI-ASQ National Accreditation Board. Refer to certificate and scope of accreditation AT-1445.

Table of Contents

1	General Information	17
1.1	Scope	17
1.2	Test Facility	17
1.3	Related Submittal(s)/Grant(s)	17
1.4	Modifications	17
2	Tested System Details	18
2.1	Test Configurations	19
3	Test Distance and Exercising the EUT	29
4	Conducted Limits - §15.207, IC RSS-Gen	30
4.1	Conducted Emission Limits Test Data	30
4.1.1	Test Configuration #1 (TC #1)	30
5	Modulated Bandwidth – ANSI C63.10 6.9, RSS-211 5.1(a)	32
5.1	Modulated Bandwidth Test Procedure	32
6	Radiated Emission Limits - §15.209, IC RSS-Gen, RSS-211 5.3	34
6.1	Radiated Emission Limits Test Procedure	34
6.2	Field Strength Calculation	34
6.3	Radiated Emission Limits Test Data 9 kHz – 26 GHz	35
6.3.1	Radiated Emissions Carrier Test Data - Steel Container	35
6.3.1.1	Radiated Emissions Carrier Test Data - TC#1 Steel Container	35
6.3.1.2	Radiated Emissions Below 1 GHz Test Data – TC#1 Steel Container	36
6.3.1.3	Radiated Emissions 1 GHz – 26 GHz Test Data – TC#1 Steel Container	44
6.3.1.4	Radiated Emissions Carrier Test Data - TC#2 Steel Container	54
6.3.1.5	Radiated Emissions Below 1 GHz Test Data – TC#2 Steel Container	55
6.3.1.6	Radiated Emissions 1 GHz – 26 GHz Test Data – TC#2 Steel Container	63
6.3.1.1	Radiated Emissions Carrier Test Data - TC#3 Steel Container	75
6.3.1.2	Radiated Emissions Below 1 GHz Test Data – TC#3 Steel Container	76
6.3.1.3	Radiated Emissions 1 GHz – 26 GHz Test Data – TC#3 Steel Container	84
6.3.1.1	Radiated Emissions Carrier Test Data - TC#4 Steel Container	96
6.3.1.2	Radiated Emissions Below 1 GHz Test Data – TC#4 Steel Container	97
6.3.1.3	Radiated Emissions 1 GHz – 26 GHz Test Data – TC#4 Steel Container	105
6.3.1.1	Radiated Emissions Carrier Test Data - TC#5 Steel Container	117
6.3.1.2	Radiated Emissions Below 1 GHz Test Data – TC#5 Steel Container	118
6.3.1.3	Radiated Emissions 1 GHz – 26 GHz Test Data – TC#5 Steel Container	126
6.3.1.4	Radiated Emissions Carrier Test Data - TC#6 Steel Container	138
6.3.1.5	Radiated Emissions Below 1 GHz Test Data – TC#6 Steel Container	139
6.3.1.6	Radiated Emissions 1 GHz – 26 GHz Test Data – TC#6 Steel Container	147
6.3.1.7	Radiated Emissions Carrier Test Data - TC#7 Steel Container	159
6.3.1.8	Radiated Emissions Below 1 GHz Test Data – TC#7 Steel Container	160
6.3.1.9	Radiated Emissions 1 GHz – 26 GHz Test Data – TC#7 Steel Container	168
6.3.1.10	Radiated Emissions Carrier Test Data - TC#8 Steel Container	180
6.3.1.11	Radiated Emissions Below 1 GHz Test Data – TC#8 Steel Container	181
6.3.1.12	Radiated Emissions 1 GHz – 26 GHz Test Data – TC#8 Steel Container	189
6.3.1.13	Radiated Emissions Carrier Test Data - TC#9 Steel Container	201
6.3.1.14	Radiated Emissions Below 1 GHz Test Data – TC#9 Steel Container	202
6.3.1.15	Radiated Emissions 1 GHz – 26 GHz Test Data – TC#9 Steel Container	210
6.3.2	Radiated Emissions Carrier Test Data - Concrete Container	222
6.3.2.1	Radiated Emissions Carrier Test Data - TC#1 Concrete Container	222
6.3.2.2	Radiated Emissions Below 1 GHz Test Data – TC#1 Concrete Container	223
6.3.2.3	Radiated Emissions 1 GHz – 26 GHz Test Data – TC#1 Concrete Container	231
6.3.2.4	Radiated Emissions Carrier Test Data - TC#2 Concrete Container	243
6.3.2.5	Radiated Emissions Below 1 GHz Test Data – TC#2 Concrete Container	244
6.3.2.6	Radiated Emissions 1 GHz – 26 GHz Test Data – TC#2 Concrete Container	252
6.3.2.7	Radiated Emissions Carrier Test Data - TC#3 Concrete Container	264

6.3.2.8	Radiated Emissions Below 1 GHz Test Data – TC#3 Concrete Container	265
6.3.2.9	Radiated Emissions 1 GHz – 26 GHz Test Data – TC#3 Concrete Container	273
6.3.2.10	Radiated Emissions Carrier Test Data - TC#4 Concrete Container	285
6.3.2.11	Radiated Emissions Below 1 GHz Test Data – TC#4 Concrete Container	286
6.3.2.12	Radiated Emissions 1 GHz – 26 GHz Test Data – TC#4 Concrete Container	294
6.3.2.13	Radiated Emissions Carrier Test Data - TC#5 Concrete Container	306
6.3.2.14	Radiated Emissions Below 1 GHz Test Data – TC#5 Concrete Container	307
6.3.2.15	Radiated Emissions 1 GHz – 26 GHz Test Data – TC#5 Concrete Container	315
6.3.2.16	Radiated Emissions Carrier Test Data - TC#6 Concrete Container	327
6.3.2.17	Radiated Emissions Below 1 GHz Test Data – TC#6 Concrete Container	328
6.3.2.18	Radiated Emissions 1 GHz – 26 GHz Test Data – TC#6 Concrete Container	336
6.3.2.19	Radiated Emissions Carrier Test Data - TC#7 Concrete Container	348
6.3.2.20	Radiated Emissions Below 1 GHz Test Data – TC#7 Concrete Container	349
6.3.2.21	Radiated Emissions 1 GHz – 26 GHz Test Data – TC#7 Concrete Container	357
6.3.2.22	Radiated Emissions Carrier Test Data - TC#8 Concrete Container	369
6.3.2.23	Radiated Emissions Below 1 GHz Test Data – TC#8 Concrete Container	370
6.3.2.24	Radiated Emissions 1 GHz – 26 GHz Test Data – TC#8 Concrete Container	378
6.3.2.25	Radiated Emissions Carrier Test Data - TC#9 Concrete Container	390
6.3.2.26	Radiated Emissions Below 1 GHz Test Data – TC#9 Concrete Container	391
6.3.2.27	Radiated Emissions 1 GHz – 26 GHz Test Data – TC#9 Concrete Container	399
6.3.3	Radiated Emissions Carrier Test Data Fiberglass Container	411
6.3.3.1	Radiated Emissions Carrier Test Data - TC#1 Fiberglass Container	411
6.3.3.2	Radiated Emissions Below 1 GHz Test Data – TC#1 Fiberglass Container	412
6.3.3.3	Radiated Emissions 1 GHz – 26 GHz Test Data – TC#1 Fiberglass Container	420
6.3.3.4	Radiated Emissions Carrier Test Data - TC#2 Fiberglass Container	432
6.3.3.5	Radiated Emissions Below 1 GHz Test Data – TC#2 Fiberglass Container	433
6.3.3.6	Radiated Emissions 1 GHz – 26 GHz Test Data – TC#2 Fiberglass Container	441
6.3.3.7	Radiated Emissions Carrier Test Data - TC#3 Steel Fiberglass Container	453
6.3.3.8	Radiated Emissions Below 1 GHz Test Data – TC#3 Fiberglass Container	454
6.3.3.9	Radiated Emissions 1 GHz – 26 GHz Test Data – TC#3 Fiberglass Container	462
6.3.3.10	Radiated Emissions Carrier Test Data - TC#4 Fiberglass Container	474
6.3.3.11	Radiated Emissions Below 1 GHz Test Data – TC#4 Fiberglass Container	475
6.3.3.12	Radiated Emissions 1 GHz – 26 GHz Test Data – TC#4 Fiberglass Container	483
6.3.3.13	Radiated Emissions Carrier Test Data - TC#5 Fiberglass Container	495
6.3.3.14	Radiated Emissions Below 1 GHz Test Data – TC#5 Fiberglass Container	496
6.3.3.15	Radiated Emissions 1 GHz – 26 GHz Test Data – TC#5 Fiberglass Container	504
6.3.3.16	Radiated Emissions Carrier Test Data - TC#6 Fiberglass Container	516
6.3.3.17	Radiated Emissions Below 1 GHz Test Data – TC#6 Fiberglass Container	517
6.3.3.18	Radiated Emissions 1 GHz – 26 GHz Test Data – TC#6 Fiberglass Container	525
6.3.3.19	Radiated Emissions Carrier Test Data - TC#7 Fiberglass Container	537
6.3.3.20	Radiated Emissions Below 1 GHz Test Data – TC#7 Fiberglass Container	538
6.3.3.21	Radiated Emissions 1 GHz – 26 GHz Test Data – TC#7 Fiberglass Container	546
6.3.3.22	Radiated Emissions Carrier Test Data - TC#8 Fiberglass Container	558
6.3.3.23	Radiated Emissions Below 1 GHz Test Data – TC#8 Fiberglass Container	559
6.3.3.24	Radiated Emissions 1 GHz – 26 GHz Test Data – TC#8 Fiberglass Container	567
6.3.3.25	Radiated Emissions Carrier Test Data - TC#9 Fiberglass Container	579
6.3.3.26	Radiated Emissions Below 1 GHz Test Data – TC#9 Fiberglass Container	580
6.3.3.27	Radiated Emissions 1 GHz – 26 GHz Test Data – TC#9 Fiberglass Container	588
7	Conclusion	601

Table of Appendices

Appendix A: Test Configuration Test Photographs	602
Appendix B: RF Exposure FCC Rules and Regulations Part 1.1307, 1.1310, 2.1091, 2.1093, RSS-GEN	658

Table of Tables

Table 2-1: Equipment under Test (EUT).....	18
Table 2-2: Test Configuration #1 (TC #1)	19
Table 2-3: Test Configuration #2 (TC #2)	20
Table 2-4: Test Configuration #3 (TC #3)	21
Table 2-5: Test Configuration #4 (TC #4)	22
Table 2-6: Test Configuration #5 (TC #5)	23
Table 2-7: Test Configuration #6 (TC #6)	24
Table 2-8: Test Configuration #7 (TC #7)	25
Table 2-9: Test Configuration #8 (TC #8)	26
Table 2-10: Test Configuration #9 (TC #9).....	27
Table 4-1: Conducted Line Emissions Test Equipment.....	31
Table 5-1: Modulated Bandwidth Data.....	32
Table 6-1: Radiated Emissions of Carrier – TC #1 Steel Container	35
Table 6-2: Radiated Emissions of Carrier – TC #2 Steel Container	54
Table 6-3: Radiated Emissions of Carrier – TC #3 Steel Container	75
Table 6-4: Radiated Emissions of Carrier – TC #4 Steel Container	96
Table 6-5: Radiated Emissions of Carrier – TC #5 Steel Container	117
Table 6-6: Radiated Emissions of Carrier – TC #6 Steel Container	138
Table 6-7: Radiated Emissions of Carrier – TC #7 Steel Container	159
Table 6-8: Radiated Emissions of Carrier – TC #8 Steel Container	180
Table 6-9: Radiated Emissions of Carrier – TC #9 Steel Container	201
Table 6-10: Radiated Emissions of Carrier – TC #1 Concrete Container	222
Table 6-11: Radiated Emissions of Carrier – TC #2 Concrete Container	243
Table 6-12: Radiated Emissions of Carrier – TC #3 Concrete Container	264
Table 6-13: Radiated Emissions of Carrier – TC #4 Concrete Container	285
Table 6-14: Radiated Emissions of Carrier – TC #5 Concrete Container	306
Table 6-15: Radiated Emissions of Carrier – TC #6 Concrete Container	327
Table 6-16: Radiated Emissions of Carrier – TC #7 Concrete Container	348
Table 6-17: Radiated Emissions of Carrier – TC #8 Concrete Container	369
Table 6-18: Radiated Emissions of Carrier – TC #9 Concrete Container	390
Table 6-19: Radiated Emissions of Carrier – TC #1 Fiberglass Container	411
Table 6-20: Radiated Emissions of Carrier – TC #2 Fiberglass Container	432
Table 6-21: Radiated Emissions of Carrier – TC #3 Fiberglass Container	453
Table 6-22: Radiated Emissions of Carrier – TC #4 Fiberglass Container	474
Table 6-23: Radiated Emissions of Carrier – TC #5 Fiberglass Container	495
Table 6-24: Radiated Emissions of Carrier – TC #6 Fiberglass Container	516
Table 6-25: Radiated Emissions of Carrier – TC #7 Fiberglass Container	537
Table 6-26: Radiated Emissions of Carrier – TC #8 Fiberglass Container	558
Table 6-27: Radiated Emissions of Carrier – TC #9 Fiberglass Container	579
Table 6-28: Radiated Emissions Test Equipment	600

Table of Plots

Plot 4-1: Conducted Emissions Transmit - Phase (TC #1)	30
Plot 4-2: Conducted Emissions Transmit – Neutral (TC #1)	31
Plot 5-1: Modulated Bandwidth - TC #1	32
Plot 6-1: Radiated Emissions of Carrier - TC #1 Steel Container	35
Plot 6-2: Radiated Emissions Transmit – 9 kHz – 150 kHz Horizontal Peak/Average	36
Plot 6-3: Radiated Emissions Transmit – 9 kHz – 150 kHz Vertical Peak/Average	37
Plot 6-4: Radiated Emissions Transmit – 150 kHz – 2 MHz Horizontal Peak/Average	38
Plot 6-5: Radiated Emissions Transmit – 150 kHz – 2 MHz Vertical Peak/Average	39
Plot 6-6: Radiated Emissions Transmit – 2 MHz – 30 MHz Horizontal Peak/Average	40

Plot 6-7: Radiated Emissions Transmit – 2 MHz – 30 MHz Vertical Peak/Average	41
Plot 6-8: Radiated Emissions Transmit – 30 MHz – 1 GHz Horizontal Peak/Average	42
Plot 6-9: Radiated Emissions Transmit – 30 MHz – 1 GHz Vertical Peak/Average	43
Plot 6-10: Radiated Emissions 1 GHz – 2 GHz Horizontal Peak/Average	44
Plot 6-11: Radiated Emissions 1 GHz – 2 GHz Vertical Peak/Average.....	45
Plot 6-12: Radiated Emissions 2 GHz – 4 GHz Horizontal Peak/Average	46
Plot 6-13: Radiated Emissions 2 GHz – 4 GHz Vertical Peak/Average.....	47
Plot 6-14: Radiated Emissions 4 GHz – 8 GHz Horizontal Peak/Average	48
Plot 6-15: Radiated Emissions 4 GHz – 8 GHz Vertical Peak/Average.....	49
Plot 6-16: Radiated Emissions 8 GHz – 12 GHz Horizontal Peak/Average	50
Plot 6-17: Radiated Emissions 8 GHz – 12 GHz Vertical Peak/Average.....	51
Plot 6-18: Radiated Emissions 18 GHz – 26 GHz Horizontal Peak/Average	52
Plot 6-19: Radiated Emissions 18 GHz – 26 GHz Vertical Peak/Average.....	53
Plot 6-20: Radiated Emissions of Carrier - TC #2 Steel Container	54
Plot 6-21: Radiated Emissions Transmit – 9 kHz – 150 kHz Horizontal Peak/Average	55
Plot 6-22: Radiated Emissions Transmit – 9 kHz – 150 kHz Vertical Peak/Average	56
Plot 6-23: Radiated Emissions Transmit – 150 kHz – 2 MHz Horizontal Peak/Average	57
Plot 6-24: Radiated Emissions Transmit – 150 kHz – 2 MHz Vertical Peak/Average	58
Plot 6-25: Radiated Emissions Transmit – 2 MHz – 30 MHz Horizontal Peak/Average	59
Plot 6-26: Radiated Emissions Transmit – 2 MHz – 30 MHz Vertical Peak/Average	60
Plot 6-27: Radiated Emissions Transmit – 30 MHz – 1 GHz Horizontal Peak/Average	61
Plot 6-28: Radiated Emissions Transmit – 30 MHz – 1 GHz Vertical Peak/Average	62
Plot 6-29: Radiated Emissions 1 GHz – 2 GHz Horizontal Peak/Average	63
Plot 6-30: Radiated Emissions 1 GHz – 2 GHz Vertical Peak/Average.....	64
Plot 6-31: Radiated Emissions 2 GHz – 4 GHz Horizontal Peak/Average	65
Plot 6-32: Radiated Emissions 2 GHz – 4 GHz Vertical Peak/Average.....	66
Plot 6-33: Radiated Emissions 4 GHz – 8 GHz Horizontal Peak/Average	67
Plot 6-34: Radiated Emissions 4 GHz – 8 GHz Vertical Peak/Average.....	68
Plot 6-35: Radiated Emissions 8 GHz – 12 GHz Horizontal Peak/Average	69
Plot 6-36: Radiated Emissions 8 GHz – 12 GHz Vertical Peak/Average.....	70
Plot 6-35: Radiated Emissions 12 GHz – 18 GHz Horizontal Peak/Average	71
Plot 6-36: Radiated Emissions 12 GHz – 18 GHz Vertical Peak/Average.....	72
Plot 6-37: Radiated Emissions 18 GHz – 26 GHz Horizontal Peak/Average	73
Plot 6-38: Radiated Emissions 18 GHz – 26 GHz Vertical Peak/Average.....	74
Plot 6-39: Radiated Emissions of Carrier - TC #3 Steel Container	75
Plot 6-40: Radiated Emissions Transmit – 9 kHz – 150 kHz Horizontal Peak/Average	76
Plot 6-41: Radiated Emissions Transmit – 9 kHz – 150 kHz Vertical Peak/Average	77
Plot 6-42: Radiated Emissions Transmit – 150 kHz – 2 MHz Horizontal Peak/Average	78
Plot 6-43: Radiated Emissions Transmit – 150 kHz – 2 MHz Vertical Peak/Average	79
Plot 6-44: Radiated Emissions Transmit – 2 MHz – 30 MHz Horizontal Peak/Average	80
Plot 6-45: Radiated Emissions Transmit – 2 MHz – 30 MHz Vertical Peak/Average	81
Plot 6-46: Radiated Emissions Transmit – 30 MHz – 1 GHz Horizontal Peak/Average	82
Plot 6-47: Radiated Emissions Transmit – 30 MHz – 1 GHz Vertical Peak/Average	83
Plot 6-48: Radiated Emissions 1 GHz – 2 GHz Horizontal Peak/Average	84
Plot 6-49: Radiated Emissions 1 GHz – 2 GHz Vertical Peak/Average.....	85
Plot 6-50: Radiated Emissions 2 GHz – 4 GHz Horizontal Peak/Average	86
Plot 6-51: Radiated Emissions 2 GHz – 4 GHz Vertical Peak/Average.....	87
Plot 6-52: Radiated Emissions 4 GHz – 8 GHz Horizontal Peak/Average	88
Plot 6-53: Radiated Emissions 4 GHz – 8 GHz Vertical Peak/Average.....	89
Plot 6-54: Radiated Emissions 8 GHz – 12 GHz Horizontal Peak/Average	90
Plot 6-55: Radiated Emissions 8 GHz – 12 GHz Vertical Peak/Average.....	91
Plot 6-56: Radiated Emissions 12 GHz – 18 GHz Horizontal Peak/Average	92
Plot 6-57: Radiated Emissions 12 GHz – 18 GHz Vertical Peak/Average.....	93
Plot 6-58: Radiated Emissions 18 GHz – 26 GHz Horizontal Peak/Average	94
Plot 6-59: Radiated Emissions 18 GHz – 26 GHz Vertical Peak/Average.....	95
Plot 6-60: Radiated Emissions of Carrier - TC #4 Steel Container	96

Plot 6-61: Radiated Emissions Transmit – 9 kHz – 150 kHz Horizontal Peak/Average	97
Plot 6-62: Radiated Emissions Transmit – 9 kHz – 150 kHz Vertical Peak/Average	98
Plot 6-63: Radiated Emissions Transmit – 150 kHz – 2 MHz Horizontal Peak/Average	99
Plot 6-64: Radiated Emissions Transmit – 150 kHz – 2 MHz Vertical Peak/Average	100
Plot 6-65: Radiated Emissions Transmit – 2 MHz – 30 MHz Horizontal Peak/Average	101
Plot 6-66: Radiated Emissions Transmit – 2 MHz – 30 MHz Vertical Peak/Average	102
Plot 6-67: Radiated Emissions Transmit – 30 MHz – 1 GHz Horizontal Peak/Average	103
Plot 6-68: Radiated Emissions Transmit – 30 MHz – 1 GHz Vertical Peak/Average	104
Plot 6-69: Radiated Emissions 1 GHz – 2 GHz Horizontal Peak/Average	105
Plot 6-70: Radiated Emissions 1 GHz – 2 GHz Vertical Peak/Average.....	106
Plot 6-71: Radiated Emissions 2 GHz – 4 GHz Horizontal Peak/Average	107
Plot 6-72: Radiated Emissions 2 GHz – 4 GHz Vertical Peak/Average.....	108
Plot 6-73: Radiated Emissions 4 GHz – 8 GHz Horizontal Peak/Average	109
Plot 6-74: Radiated Emissions 4 GHz – 8 GHz Vertical Peak/Average.....	110
Plot 6-75: Radiated Emissions 8 GHz – 12 GHz Horizontal Peak/Average	111
Plot 6-76: Radiated Emissions 8 GHz – 12 GHz Vertical Peak/Average.....	112
Plot 6-77: Radiated Emissions 12 GHz – 18 GHz Horizontal Peak/Average	113
Plot 6-78: Radiated Emissions 12 GHz – 18 GHz Vertical Peak/Average.....	114
Plot 6-79: Radiated Emissions 18 GHz – 26 GHz Horizontal Peak/Average	115
Plot 6-80: Radiated Emissions 18 GHz – 26 GHz Vertical Peak/Average.....	116
Plot 6-81: Radiated Emissions of Carrier - TC #5 Steel Container	117
Plot 6-82: Radiated Emissions Transmit – 9 kHz – 150 kHz Horizontal Peak/Average	118
Plot 6-83: Radiated Emissions Transmit – 9 kHz – 150 kHz Vertical Peak/Average	119
Plot 6-84: Radiated Emissions Transmit – 150 kHz – 2 MHz Horizontal Peak/Average	120
Plot 6-85: Radiated Emissions Transmit – 150 kHz – 2 MHz Vertical Peak/Average	121
Plot 6-86: Radiated Emissions Transmit – 2 MHz – 30 MHz Horizontal Peak/Average	122
Plot 6-87: Radiated Emissions Transmit – 2 MHz – 30 MHz Vertical Peak/Average	123
Plot 6-88: Radiated Emissions Transmit – 30 MHz – 1 GHz Horizontal Peak/Average	124
Plot 6-89: Radiated Emissions Transmit – 30 MHz – 1 GHz Vertical Peak/Average	125
Plot 6-90: Radiated Emissions 1 GHz – 2 GHz Horizontal Peak/Average	126
Plot 6-91: Radiated Emissions 1 GHz – 2 GHz Vertical Peak/Average.....	127
Plot 6-92: Radiated Emissions 2 GHz – 4 GHz Horizontal Peak/Average	128
Plot 6-93: Radiated Emissions 2 GHz – 4 GHz Vertical Peak/Average.....	129
Plot 6-94: Radiated Emissions 4 GHz – 8 GHz Horizontal Peak/Average	130
Plot 6-95: Radiated Emissions 4 GHz – 8 GHz Vertical Peak/Average.....	131
Plot 6-96: Radiated Emissions 8 GHz – 12 GHz Horizontal Peak/Average	132
Plot 6-97: Radiated Emissions 8 GHz – 12 GHz Vertical Peak/Average.....	133
Plot 6-98: Radiated Emissions 12 GHz – 18 GHz Horizontal Peak/Average	134
Plot 6-99: Radiated Emissions 12 GHz – 18 GHz Vertical Peak/Average.....	135
Plot 6-100: Radiated Emissions 18 GHz – 26 GHz Horizontal Peak/Average	136
Plot 6-101: Radiated Emissions 18 GHz – 26 GHz Vertical Peak/Average	137
Plot 6-102: Radiated Emissions of Carrier - TC #6 Steel Container.....	138
Plot 6-103: Radiated Emissions Transmit – 9 kHz – 150 kHz Horizontal Peak/Average	139
Plot 6-104: Radiated Emissions Transmit – 9 kHz – 150 kHz Vertical Peak/Average	140
Plot 6-105: Radiated Emissions Transmit – 150 kHz – 2 MHz Horizontal Peak/Average	141
Plot 6-106: Radiated Emissions Transmit – 150 kHz – 2 MHz Vertical Peak/Average	142
Plot 6-107: Radiated Emissions Transmit – 2 MHz – 30 MHz Horizontal Peak/Average	143
Plot 6-108: Radiated Emissions Transmit – 2 MHz – 30 MHz Vertical Peak/Average	144
Plot 6-109: Radiated Emissions Transmit – 30 MHz – 1 GHz Horizontal Peak/Average	145
Plot 6-110: Radiated Emissions Transmit – 30 MHz – 1 GHz Vertical Peak/Average	146
Plot 6-111: Radiated Emissions 1 GHz – 2 GHz Horizontal Peak/Average	147
Plot 6-112: Radiated Emissions 1 GHz – 2 GHz Vertical Peak/Average	148
Plot 6-113: Radiated Emissions 2 GHz – 4 GHz Horizontal Peak/Average	149
Plot 6-114: Radiated Emissions 2 GHz – 4 GHz Vertical Peak/Average	150
Plot 6-115: Radiated Emissions 4 GHz – 8 GHz Horizontal Peak/Average	151
Plot 6-116: Radiated Emissions 4 GHz – 8 GHz Vertical Peak/Average	152

Plot 6-117:	Radiated Emissions 8 GHz – 12 GHz Horizontal Peak/Average	153
Plot 6-118:	Radiated Emissions 8 GHz – 12 GHz Vertical Peak/Average	154
Plot 6-119:	Radiated Emissions 12 GHz – 18 GHz Horizontal Peak/Average	155
Plot 6-120:	Radiated Emissions 12 GHz – 18 GHz Vertical Peak/Average	156
Plot 6-121:	Radiated Emissions 18 GHz – 26 GHz Horizontal Peak/Average	157
Plot 6-122:	Radiated Emissions 18 GHz – 26 GHz Vertical Peak/Average	158
Plot 6-123:	Radiated Emissions of Carrier - TC #7 Steel Container.....	159
Plot 6-124:	Radiated Emissions Transmit – 9 kHz – 150 kHz Horizontal Peak/Average	160
Plot 6-125:	Radiated Emissions Transmit – 9 kHz – 150 kHz Vertical Peak/Average	161
Plot 6-126:	Radiated Emissions Transmit – 150 kHz – 2 MHz Horizontal Peak/Average.....	162
Plot 6-127:	Radiated Emissions Transmit – 150 kHz – 2 MHz Vertical Peak/Average	163
Plot 6-128:	Radiated Emissions Transmit – 2 MHz – 30 MHz Horizontal Peak/Average	164
Plot 6-129:	Radiated Emissions Transmit – 2 MHz – 30 MHz Vertical Peak/Average.....	165
Plot 6-130:	Radiated Emissions Transmit – 30 MHz – 1 GHz Horizontal Peak/Average.....	166
Plot 6-131:	Radiated Emissions Transmit – 30 MHz – 1 GHz Vertical Peak/Average	167
Plot 6-132:	Radiated Emissions 1 GHz – 2 GHz Horizontal Peak/Average	168
Plot 6-133:	Radiated Emissions 1 GHz – 2 GHz Vertical Peak/Average	169
Plot 6-134:	Radiated Emissions 2 GHz – 4 GHz Horizontal Peak/Average	170
Plot 6-135:	Radiated Emissions 2 GHz – 4 GHz Vertical Peak/Average	171
Plot 6-136:	Radiated Emissions 4 GHz – 8 GHz Horizontal Peak/Average	172
Plot 6-137:	Radiated Emissions 4 GHz – 8 GHz Vertical Peak/Average	173
Plot 6-138:	Radiated Emissions 8 GHz – 12 GHz Horizontal Peak/Average	174
Plot 6-139:	Radiated Emissions 8 GHz – 12 GHz Vertical Peak/Average	175
Plot 6-140:	Radiated Emissions 12 GHz – 18 GHz Horizontal Peak/Average	176
Plot 6-141:	Radiated Emissions 12 GHz – 18 GHz Vertical Peak/Average	177
Plot 6-142:	Radiated Emissions 18 GHz – 26 GHz Horizontal Peak/Average	178
Plot 6-143:	Radiated Emissions 18 GHz – 26 GHz Vertical Peak/Average	179
Plot 6-144:	Radiated Emissions of Carrier - TC #8 Steel Container.....	180
Plot 6-145:	Radiated Emissions Transmit – 9 kHz – 150 kHz Horizontal Peak/Average	181
Plot 6-146:	Radiated Emissions Transmit – 9 kHz – 150 kHz Vertical Peak/Average	182
Plot 6-147:	Radiated Emissions Transmit – 150 kHz – 2 MHz Horizontal Peak/Average.....	183
Plot 6-148:	Radiated Emissions Transmit – 150 kHz – 2 MHz Vertical Peak/Average.....	184
Plot 6-149:	Radiated Emissions Transmit – 2 MHz – 30 MHz Horizontal Peak/Average	185
Plot 6-150:	Radiated Emissions Transmit – 2 MHz – 30 MHz Vertical Peak/Average.....	186
Plot 6-151:	Radiated Emissions Transmit – 30 MHz – 1 GHz Horizontal Peak/Average.....	187
Plot 6-152:	Radiated Emissions Transmit – 30 MHz – 1 GHz Vertical Peak/Average	188
Plot 6-153:	Radiated Emissions 1 GHz – 2 GHz Horizontal Peak/Average	189
Plot 6-154:	Radiated Emissions 1 GHz – 2 GHz Vertical Peak/Average	190
Plot 6-155:	Radiated Emissions 2 GHz – 4 GHz Horizontal Peak/Average	191
Plot 6-156:	Radiated Emissions 2 GHz – 4 GHz Vertical Peak/Average	192
Plot 6-157:	Radiated Emissions 4 GHz – 8 GHz Horizontal Peak/Average	193
Plot 6-158:	Radiated Emissions 4 GHz – 8 GHz Vertical Peak/Average	194
Plot 6-159:	Radiated Emissions 8 GHz – 12 GHz Horizontal Peak/Average	195
Plot 6-160:	Radiated Emissions 8 GHz – 12 GHz Vertical Peak/Average	196
Plot 6-161:	Radiated Emissions 12 GHz – 18 GHz Horizontal Peak/Average	197
Plot 6-162:	Radiated Emissions 12 GHz – 18 GHz Vertical Peak/Average	198
Plot 6-163:	Radiated Emissions 18 GHz – 26 GHz Horizontal Peak/Average	199
Plot 6-164:	Radiated Emissions 18 GHz – 26 GHz Vertical Peak/Average	200
Plot 6-165:	Radiated Emissions of Carrier - TC #9 Steel Container.....	201
Plot 6-166:	Radiated Emissions Transmit – 9 kHz – 150 kHz Horizontal Peak/Average	202
Plot 6-167:	Radiated Emissions Transmit – 9 kHz – 150 kHz Vertical Peak/Average	203
Plot 6-168:	Radiated Emissions Transmit – 150 kHz – 2 MHz Horizontal Peak/Average.....	204
Plot 6-169:	Radiated Emissions Transmit – 150 kHz – 2 MHz Vertical Peak/Average.....	205
Plot 6-170:	Radiated Emissions Transmit – 2 MHz – 30 MHz Horizontal Peak/Average	206
Plot 6-171:	Radiated Emissions Transmit – 2 MHz – 30 MHz Vertical Peak/Average.....	207
Plot 6-172:	Radiated Emissions Transmit – 30 MHz – 1 GHz Horizontal Peak/Average.....	208

Plot 6-173:	Radiated Emissions Transmit – 30 MHz – 1 GHz Vertical Peak/Average	209
Plot 6-174:	Radiated Emissions 1 GHz – 2 GHz Horizontal Peak/Average	210
Plot 6-175:	Radiated Emissions 1 GHz – 2 GHz Vertical Peak/Average	211
Plot 6-176:	Radiated Emissions 2 GHz – 4 GHz Horizontal Peak/Average	212
Plot 6-177:	Radiated Emissions 2 GHz – 4 GHz Vertical Peak/Average	213
Plot 6-178:	Radiated Emissions 4 GHz – 8 GHz Horizontal Peak/Average	214
Plot 6-179:	Radiated Emissions 4 GHz – 8 GHz Vertical Peak/Average	215
Plot 6-180:	Radiated Emissions 8 GHz – 12 GHz Horizontal Peak/Average	216
Plot 6-181:	Radiated Emissions 8 GHz – 12 GHz Vertical Peak/Average	217
Plot 6-182:	Radiated Emissions 12 GHz – 18 GHz Horizontal Peak/Average	218
Plot 6-183:	Radiated Emissions 12 GHz – 18 GHz Vertical Peak/Average	219
Plot 6-184:	Radiated Emissions 18 GHz – 26 GHz Horizontal Peak/Average	220
Plot 6-185:	Radiated Emissions 18 GHz – 26 GHz Vertical Peak/Average	221
Plot 6-186:	Radiated Emissions of Carrier - TC #1 Concrete Container	222
Plot 6-187:	Radiated Emissions Transmit – 9 kHz – 150 kHz Horizontal Peak/Average	223
Plot 6-188:	Radiated Emissions Transmit – 9 kHz – 150 kHz Vertical Peak/Average	224
Plot 6-189:	Radiated Emissions Transmit – 150 kHz – 2 MHz Horizontal Peak/Average	225
Plot 6-190:	Radiated Emissions Transmit – 150 kHz – 2 MHz Vertical Peak/Average	226
Plot 6-191:	Radiated Emissions Transmit – 2 MHz – 30 MHz Horizontal Peak/Average	227
Plot 6-192:	Radiated Emissions Transmit – 2 MHz – 30 MHz Vertical Peak/Average	228
Plot 6-193:	Radiated Emissions Transmit – 30 MHz – 1 GHz Horizontal Peak/Average	229
Plot 6-194:	Radiated Emissions Transmit – 30 MHz – 1 GHz Vertical Peak/Average	230
Plot 6-195:	Radiated Emissions 1 GHz – 2 GHz Horizontal Peak/Average	231
Plot 6-196:	Radiated Emissions 1 GHz – 2 GHz Vertical Peak/Average	232
Plot 6-197:	Radiated Emissions 2 GHz – 4 GHz Horizontal Peak/Average	233
Plot 6-198:	Radiated Emissions 2 GHz – 4 GHz Vertical Peak/Average	234
Plot 6-199:	Radiated Emissions 4 GHz – 8 GHz Horizontal Peak/Average	235
Plot 6-200:	Radiated Emissions 4 GHz – 8 GHz Vertical Peak/Average	236
Plot 6-201:	Radiated Emissions 8 GHz – 12 GHz Horizontal Peak/Average	237
Plot 6-202:	Radiated Emissions 8 GHz – 12 GHz Vertical Peak/Average	238
Plot 6-203:	Radiated Emissions 12 GHz – 18 GHz Horizontal Peak/Average	239
Plot 6-204:	Radiated Emissions 12 GHz – 18 GHz Vertical Peak/Average	240
Plot 6-205:	Radiated Emissions 18 GHz – 26 GHz Horizontal Peak/Average	241
Plot 6-206:	Radiated Emissions 18 GHz – 26 GHz Vertical Peak/Average	242
Plot 6-207:	Radiated Emissions of Carrier - TC #2 Concrete Container	243
Plot 6-208:	Radiated Emissions Transmit – 9 kHz – 150 kHz Horizontal Peak/Average	244
Plot 6-209:	Radiated Emissions Transmit – 9 kHz – 150 kHz Vertical Peak/Average	245
Plot 6-210:	Radiated Emissions Transmit – 150 kHz – 2 MHz Horizontal Peak/Average	246
Plot 6-211:	Radiated Emissions Transmit – 150 kHz – 2 MHz Vertical Peak/Average	247
Plot 6-212:	Radiated Emissions Transmit – 2 MHz – 30 MHz Horizontal Peak/Average	248
Plot 6-213:	Radiated Emissions Transmit – 2 MHz – 30 MHz Vertical Peak/Average	249
Plot 6-214:	Radiated Emissions Transmit – 30 MHz – 1 GHz Horizontal Peak/Average	250
Plot 6-215:	Radiated Emissions Transmit – 30 MHz – 1 GHz Vertical Peak/Average	251
Plot 6-216:	Radiated Emissions 1 GHz – 2 GHz Horizontal Peak/Average	252
Plot 6-217:	Radiated Emissions 1 GHz – 2 GHz Vertical Peak/Average	253
Plot 6-218:	Radiated Emissions 2 GHz – 4 GHz Horizontal Peak/Average	254
Plot 6-219:	Radiated Emissions 2 GHz – 4 GHz Vertical Peak/Average	255
Plot 6-220:	Radiated Emissions 4 GHz – 8 GHz Horizontal Peak/Average	256
Plot 6-221:	Radiated Emissions 4 GHz – 8 GHz Vertical Peak/Average	257
Plot 6-222:	Radiated Emissions 8 GHz – 12 GHz Horizontal Peak/Average	258
Plot 6-223:	Radiated Emissions 8 GHz – 12 GHz Vertical Peak/Average	259
Plot 6-224:	Radiated Emissions 12 GHz – 18 GHz Horizontal Peak/Average	260
Plot 6-225:	Radiated Emissions 12 GHz – 18 GHz Vertical Peak/Average	261
Plot 6-226:	Radiated Emissions 18 GHz – 26 GHz Horizontal Peak/Average	262
Plot 6-227:	Radiated Emissions 18 GHz – 26 GHz Vertical Peak/Average	263
Plot 6-228:	Radiated Emissions of Carrier - TC #3 Concrete Container	264

Plot 6-229:	Radiated Emissions Transmit – 9 kHz – 150 kHz Horizontal Peak/Average	265
Plot 6-230:	Radiated Emissions Transmit – 9 kHz – 150 kHz Vertical Peak/Average	266
Plot 6-231:	Radiated Emissions Transmit – 150 kHz – 2 MHz Horizontal Peak/Average	267
Plot 6-232:	Radiated Emissions Transmit – 150 kHz – 2 MHz Vertical Peak/Average	268
Plot 6-233:	Radiated Emissions Transmit – 2 MHz – 30 MHz Horizontal Peak/Average	269
Plot 6-234:	Radiated Emissions Transmit – 2 MHz – 30 MHz Vertical Peak/Average	270
Plot 6-235:	Radiated Emissions Transmit – 30 MHz – 1 GHz Horizontal Peak/Average	271
Plot 6-236:	Radiated Emissions Transmit – 30 MHz – 1 GHz Vertical Peak/Average	272
Plot 6-237:	Radiated Emissions 1 GHz – 2 GHz Horizontal Peak/Average	273
Plot 6-238:	Radiated Emissions 1 GHz – 2 GHz Vertical Peak/Average	274
Plot 6-239:	Radiated Emissions 2 GHz – 4 GHz Horizontal Peak/Average	275
Plot 6-240:	Radiated Emissions 2 GHz – 4 GHz Vertical Peak/Average	276
Plot 6-241:	Radiated Emissions 4 GHz – 8 GHz Horizontal Peak/Average	277
Plot 6-242:	Radiated Emissions 4 GHz – 8 GHz Vertical Peak/Average	278
Plot 6-243:	Radiated Emissions 8 GHz – 12 GHz Horizontal Peak/Average	279
Plot 6-244:	Radiated Emissions 8 GHz – 12 GHz Vertical Peak/Average	280
Plot 6-245:	Radiated Emissions 12 GHz – 18 GHz Horizontal Peak/Average	281
Plot 6-246:	Radiated Emissions 12 GHz – 18 GHz Vertical Peak/Average	282
Plot 6-247:	Radiated Emissions 18 GHz – 26 GHz Horizontal Peak/Average	283
Plot 6-248:	Radiated Emissions 18 GHz – 26 GHz Vertical Peak/Average	284
Plot 6-249:	Radiated Emissions of Carrier - TC #4 Concrete Container	285
Plot 6-250:	Radiated Emissions Transmit – 9 kHz – 150 kHz Horizontal Peak/Average	286
Plot 6-251:	Radiated Emissions Transmit – 9 kHz – 150 kHz Vertical Peak/Average	287
Plot 6-252:	Radiated Emissions Transmit – 150 kHz – 2 MHz Horizontal Peak/Average	288
Plot 6-253:	Radiated Emissions Transmit – 150 kHz – 2 MHz Vertical Peak/Average	289
Plot 6-254:	Radiated Emissions Transmit – 2 MHz – 30 MHz Horizontal Peak/Average	290
Plot 6-255:	Radiated Emissions Transmit – 2 MHz – 30 MHz Vertical Peak/Average	291
Plot 6-256:	Radiated Emissions Transmit – 30 MHz – 1 GHz Horizontal Peak/Average	292
Plot 6-257:	Radiated Emissions Transmit – 30 MHz – 1 GHz Vertical Peak/Average	293
Plot 6-258:	Radiated Emissions 1 GHz – 2 GHz Horizontal Peak/Average	294
Plot 6-259:	Radiated Emissions 1 GHz – 2 GHz Vertical Peak/Average	295
Plot 6-260:	Radiated Emissions 2 GHz – 4 GHz Horizontal Peak/Average	296
Plot 6-261:	Radiated Emissions 2 GHz – 4 GHz Vertical Peak/Average	297
Plot 6-262:	Radiated Emissions 4 GHz – 8 GHz Horizontal Peak/Average	298
Plot 6-263:	Radiated Emissions 4 GHz – 8 GHz Vertical Peak/Average	299
Plot 6-264:	Radiated Emissions 8 GHz – 12 GHz Horizontal Peak/Average	300
Plot 6-265:	Radiated Emissions 8 GHz – 12 GHz Vertical Peak/Average	301
Plot 6-266:	Radiated Emissions 12 GHz – 18 GHz Horizontal Peak/Average	302
Plot 6-267:	Radiated Emissions 12 GHz – 18 GHz Vertical Peak/Average	303
Plot 6-268:	Radiated Emissions 18 GHz – 26 GHz Horizontal Peak/Average	304
Plot 6-269:	Radiated Emissions 18 GHz – 26 GHz Vertical Peak/Average	305
Plot 6-270:	Radiated Emissions of Carrier - TC #5 Concrete Container	306
Plot 6-271:	Radiated Emissions Transmit – 9 kHz – 150 kHz Horizontal Peak/Average	307
Plot 6-272:	Radiated Emissions Transmit – 9 kHz – 150 kHz Vertical Peak/Average	308
Plot 6-273:	Radiated Emissions Transmit – 150 kHz – 2 MHz Horizontal Peak/Average	309
Plot 6-274:	Radiated Emissions Transmit – 150 kHz – 2 MHz Vertical Peak/Average	310
Plot 6-275:	Radiated Emissions Transmit – 2 MHz – 30 MHz Horizontal Peak/Average	311
Plot 6-276:	Radiated Emissions Transmit – 2 MHz – 30 MHz Vertical Peak/Average	312
Plot 6-277:	Radiated Emissions Transmit – 30 MHz – 1 GHz Horizontal Peak/Average	313
Plot 6-278:	Radiated Emissions Transmit – 30 MHz – 1 GHz Vertical Peak/Average	314
Plot 6-279:	Radiated Emissions 1 GHz – 2 GHz Horizontal Peak/Average	315
Plot 6-280:	Radiated Emissions 1 GHz – 2 GHz Vertical Peak/Average	316
Plot 6-281:	Radiated Emissions 2 GHz – 4 GHz Horizontal Peak/Average	317
Plot 6-282:	Radiated Emissions 2 GHz – 4 GHz Vertical Peak/Average	318
Plot 6-283:	Radiated Emissions 4 GHz – 8 GHz Horizontal Peak/Average	319
Plot 6-284:	Radiated Emissions 4 GHz – 8 GHz Vertical Peak/Average	320

Plot 6-285:	Radiated Emissions 8 GHz – 12 GHz Horizontal Peak/Average	321
Plot 6-286:	Radiated Emissions 8 GHz – 12 GHz Vertical Peak/Average	322
Plot 6-287:	Radiated Emissions 12 GHz – 18 GHz Horizontal Peak/Average	323
Plot 6-288:	Radiated Emissions 12 GHz – 18 GHz Vertical Peak/Average	324
Plot 6-289:	Radiated Emissions 18 GHz – 26 GHz Horizontal Peak/Average	325
Plot 6-290:	Radiated Emissions 18 GHz – 26 GHz Vertical Peak/Average	326
Plot 6-291:	Radiated Emissions of Carrier - TC #6 Concrete Container	327
Plot 6-292:	Radiated Emissions Transmit – 9 kHz – 150 kHz Horizontal Peak/Average	328
Plot 6-293:	Radiated Emissions Transmit – 9 kHz – 150 kHz Vertical Peak/Average	329
Plot 6-294:	Radiated Emissions Transmit – 150 kHz – 2 MHz Horizontal Peak/Average	330
Plot 6-295:	Radiated Emissions Transmit – 150 kHz – 2 MHz Vertical Peak/Average	331
Plot 6-296:	Radiated Emissions Transmit – 2 MHz – 30 MHz Horizontal Peak/Average	332
Plot 6-297:	Radiated Emissions Transmit – 2 MHz – 30 MHz Vertical Peak/Average	333
Plot 6-298:	Radiated Emissions Transmit – 30 MHz – 1 GHz Horizontal Peak/Average	334
Plot 6-299:	Radiated Emissions Transmit – 30 MHz – 1 GHz Vertical Peak/Average	335
Plot 6-300:	Radiated Emissions 1 GHz – 2 GHz Horizontal Peak/Average	336
Plot 6-301:	Radiated Emissions 1 GHz – 2 GHz Vertical Peak/Average	337
Plot 6-302:	Radiated Emissions 2 GHz – 4 GHz Horizontal Peak/Average	338
Plot 6-303:	Radiated Emissions 2 GHz – 4 GHz Vertical Peak/Average	339
Plot 6-304:	Radiated Emissions 4 GHz – 8 GHz Horizontal Peak/Average	340
Plot 6-305:	Radiated Emissions 4 GHz – 8 GHz Vertical Peak/Average	341
Plot 6-306:	Radiated Emissions 8 GHz – 12 GHz Horizontal Peak/Average	342
Plot 6-307:	Radiated Emissions 8 GHz – 12 GHz Vertical Peak/Average	343
Plot 6-308:	Radiated Emissions 12 GHz – 18 GHz Horizontal Peak/Average	344
Plot 6-309:	Radiated Emissions 12 GHz – 18 GHz Vertical Peak/Average	345
Plot 6-310:	Radiated Emissions 18 GHz – 26 GHz Horizontal Peak/Average	346
Plot 6-311:	Radiated Emissions 18 GHz – 26 GHz Vertical Peak/Average	347
Plot 6-312:	Radiated Emissions of Carrier - TC #7 Concrete Container	348
Plot 6-313:	Radiated Emissions Transmit – 9 kHz – 150 kHz Horizontal Peak/Average	349
Plot 6-314:	Radiated Emissions Transmit – 9 kHz – 150 kHz Vertical Peak/Average	350
Plot 6-315:	Radiated Emissions Transmit – 150 kHz – 2 MHz Horizontal Peak/Average	351
Plot 6-316:	Radiated Emissions Transmit – 150 kHz – 2 MHz Vertical Peak/Average	352
Plot 6-317:	Radiated Emissions Transmit – 2 MHz – 30 MHz Horizontal Peak/Average	353
Plot 6-318:	Radiated Emissions Transmit – 2 MHz – 30 MHz Vertical Peak/Average	354
Plot 6-319:	Radiated Emissions Transmit – 30 MHz – 1 GHz Horizontal Peak/Average	355
Plot 6-320:	Radiated Emissions Transmit – 30 MHz – 1 GHz Vertical Peak/Average	356
Plot 6-321:	Radiated Emissions 1 GHz – 2 GHz Horizontal Peak/Average	357
Plot 6-322:	Radiated Emissions 1 GHz – 2 GHz Vertical Peak/Average	358
Plot 6-323:	Radiated Emissions 2 GHz – 4 GHz Horizontal Peak/Average	359
Plot 6-324:	Radiated Emissions 2 GHz – 4 GHz Vertical Peak/Average	360
Plot 6-325:	Radiated Emissions 4 GHz – 8 GHz Horizontal Peak/Average	361
Plot 6-326:	Radiated Emissions 4 GHz – 8 GHz Vertical Peak/Average	362
Plot 6-327:	Radiated Emissions 8 GHz – 12 GHz Horizontal Peak/Average	363
Plot 6-328:	Radiated Emissions 8 GHz – 12 GHz Vertical Peak/Average	364
Plot 6-329:	Radiated Emissions 12 GHz – 18 GHz Horizontal Peak/Average	365
Plot 6-330:	Radiated Emissions 12 GHz – 18 GHz Vertical Peak/Average	366
Plot 6-331:	Radiated Emissions 18 GHz – 26 GHz Horizontal Peak/Average	367
Plot 6-332:	Radiated Emissions 18 GHz – 26 GHz Vertical Peak/Average	368
Plot 6-333:	Radiated Emissions of Carrier - TC #8 Concrete Container	369
Plot 6-334:	Radiated Emissions Transmit – 9 kHz – 150 kHz Horizontal Peak/Average	370
Plot 6-335:	Radiated Emissions Transmit – 9 kHz – 150 kHz Vertical Peak/Average	371
Plot 6-336:	Radiated Emissions Transmit – 150 kHz – 2 MHz Horizontal Peak/Average	372
Plot 6-337:	Radiated Emissions Transmit – 150 kHz – 2 MHz Vertical Peak/Average	373
Plot 6-338:	Radiated Emissions Transmit – 2 MHz – 30 MHz Horizontal Peak/Average	374
Plot 6-339:	Radiated Emissions Transmit – 2 MHz – 30 MHz Vertical Peak/Average	375
Plot 6-340:	Radiated Emissions Transmit – 30 MHz – 1 GHz Horizontal Peak/Average	376

Plot 6-341:	Radiated Emissions Transmit – 30 MHz – 1 GHz Vertical Peak/Average	377
Plot 6-342:	Radiated Emissions 1 GHz – 2 GHz Horizontal Peak/Average	378
Plot 6-343:	Radiated Emissions 1 GHz – 2 GHz Vertical Peak/Average	379
Plot 6-344:	Radiated Emissions 2 GHz – 4 GHz Horizontal Peak/Average	380
Plot 6-345:	Radiated Emissions 2 GHz – 4 GHz Vertical Peak/Average	381
Plot 6-346:	Radiated Emissions 4 GHz – 8 GHz Horizontal Peak/Average	382
Plot 6-347:	Radiated Emissions 4 GHz – 8 GHz Vertical Peak/Average	383
Plot 6-348:	Radiated Emissions 8 GHz – 12 GHz Horizontal Peak/Average	384
Plot 6-349:	Radiated Emissions 8 GHz – 12 GHz Vertical Peak/Average	385
Plot 6-350:	Radiated Emissions 12 GHz – 18 GHz Horizontal Peak/Average	386
Plot 6-351:	Radiated Emissions 12 GHz – 18 GHz Vertical Peak/Average	387
Plot 6-352:	Radiated Emissions 18 GHz – 26 GHz Horizontal Peak/Average	388
Plot 6-353:	Radiated Emissions 18 GHz – 26 GHz Vertical Peak/Average	389
Plot 6-354:	Radiated Emissions of Carrier - TC #9 Concrete Container	390
Plot 6-355:	Radiated Emissions Transmit – 9 kHz – 150 kHz Horizontal Peak/Average	391
Plot 6-356:	Radiated Emissions Transmit – 9 kHz – 150 kHz Vertical Peak/Average	392
Plot 6-357:	Radiated Emissions Transmit – 150 kHz – 2 MHz Horizontal Peak/Average	393
Plot 6-358:	Radiated Emissions Transmit – 150 kHz – 2 MHz Vertical Peak/Average	394
Plot 6-359:	Radiated Emissions Transmit – 2 MHz – 30 MHz Horizontal Peak/Average	395
Plot 6-360:	Radiated Emissions Transmit – 2 MHz – 30 MHz Vertical Peak/Average	396
Plot 6-361:	Radiated Emissions Transmit – 30 MHz – 1 GHz Horizontal Peak/Average	397
Plot 6-362:	Radiated Emissions Transmit – 30 MHz – 1 GHz Vertical Peak/Average	398
Plot 6-363:	Radiated Emissions 1 GHz – 2 GHz Horizontal Peak/Average	399
Plot 6-364:	Radiated Emissions 1 GHz – 2 GHz Vertical Peak/Average	400
Plot 6-365:	Radiated Emissions 2 GHz – 4 GHz Horizontal Peak/Average	401
Plot 6-366:	Radiated Emissions 2 GHz – 4 GHz Vertical Peak/Average	402
Plot 6-367:	Radiated Emissions 4 GHz – 8 GHz Horizontal Peak/Average	403
Plot 6-368:	Radiated Emissions 4 GHz – 8 GHz Vertical Peak/Average	404
Plot 6-369:	Radiated Emissions 8 GHz – 12 GHz Horizontal Peak/Average	405
Plot 6-370:	Radiated Emissions 8 GHz – 12 GHz Vertical Peak/Average	406
Plot 6-371:	Radiated Emissions 12 GHz – 18 GHz Horizontal Peak/Average	407
Plot 6-372:	Radiated Emissions 12 GHz – 18 GHz Vertical Peak/Average	408
Plot 6-373:	Radiated Emissions 18 GHz – 26 GHz Horizontal Peak/Average	409
Plot 6-374:	Radiated Emissions 18 GHz – 26 GHz Vertical Peak/Average	410
Plot 6-375:	Radiated Emissions of Carrier - TC #1 Fiberglass Container	411
Plot 6-376:	Radiated Emissions Transmit – 9 kHz – 150 kHz Horizontal Peak/Average	412
Plot 6-377:	Radiated Emissions Transmit – 9 kHz – 150 kHz Vertical Peak/Average	413
Plot 6-378:	Radiated Emissions Transmit – 150 kHz – 2 MHz Horizontal Peak/Average	414
Plot 6-379:	Radiated Emissions Transmit – 150 kHz – 2 MHz Vertical Peak/Average	415
Plot 6-380:	Radiated Emissions Transmit – 2 MHz – 30 MHz Horizontal Peak/Average	416
Plot 6-381:	Radiated Emissions Transmit – 2 MHz – 30 MHz Vertical Peak/Average	417
Plot 6-382:	Radiated Emissions Transmit – 30 MHz – 1 GHz Horizontal Peak/Average	418
Plot 6-383:	Radiated Emissions Transmit – 30 MHz – 1 GHz Vertical Peak/Average	419
Plot 6-384:	Radiated Emissions 1 GHz – 2 GHz Horizontal Peak/Average	420
Plot 6-385:	Radiated Emissions 1 GHz – 2 GHz Vertical Peak/Average	421
Plot 6-386:	Radiated Emissions 2 GHz – 4 GHz Horizontal Peak/Average	422
Plot 6-387:	Radiated Emissions 2 GHz – 4 GHz Vertical Peak/Average	423
Plot 6-388:	Radiated Emissions 4 GHz – 8 GHz Horizontal Peak/Average	424
Plot 6-389:	Radiated Emissions 4 GHz – 8 GHz Vertical Peak/Average	425
Plot 6-390:	Radiated Emissions 8 GHz – 12 GHz Horizontal Peak/Average	426
Plot 6-391:	Radiated Emissions 8 GHz – 12 GHz Vertical Peak/Average	427
Plot 6-392:	Radiated Emissions 12 GHz – 18 GHz Horizontal Peak/Average	428
Plot 6-393:	Radiated Emissions 12 GHz – 18 GHz Vertical Peak/Average	429
Plot 6-394:	Radiated Emissions 18 GHz – 26 GHz Horizontal Peak/Average	430
Plot 6-395:	Radiated Emissions 18 GHz – 26 GHz Vertical Peak/Average	431
Plot 6-396:	Radiated Emissions of Carrier - TC #2 Fiberglass Container	432

Plot 6-397:	Radiated Emissions Transmit – 9 kHz – 150 kHz Horizontal Peak/Average	433
Plot 6-398:	Radiated Emissions Transmit – 9 kHz – 150 kHz Vertical Peak/Average	434
Plot 6-399:	Radiated Emissions Transmit – 150 kHz – 2 MHz Horizontal Peak/Average	435
Plot 6-400:	Radiated Emissions Transmit – 150 kHz – 2 MHz Vertical Peak/Average	436
Plot 6-401:	Radiated Emissions Transmit – 2 MHz – 30 MHz Horizontal Peak/Average	437
Plot 6-402:	Radiated Emissions Transmit – 2 MHz – 30 MHz Vertical Peak/Average	438
Plot 6-403:	Radiated Emissions Transmit – 30 MHz – 1 GHz Horizontal Peak/Average	439
Plot 6-404:	Radiated Emissions Transmit – 30 MHz – 1 GHz Vertical Peak/Average	440
Plot 6-405:	Radiated Emissions 1 GHz – 2 GHz Horizontal Peak/Average	441
Plot 6-406:	Radiated Emissions 1 GHz – 2 GHz Vertical Peak/Average	442
Plot 6-407:	Radiated Emissions 2 GHz – 4 GHz Horizontal Peak/Average	443
Plot 6-408:	Radiated Emissions 2 GHz – 4 GHz Vertical Peak/Average	444
Plot 6-409:	Radiated Emissions 4 GHz – 8 GHz Horizontal Peak/Average	445
Plot 6-410:	Radiated Emissions 4 GHz – 8 GHz Vertical Peak/Average	446
Plot 6-411:	Radiated Emissions 8 GHz – 12 GHz Horizontal Peak/Average	447
Plot 6-412:	Radiated Emissions 8 GHz – 12 GHz Vertical Peak/Average	448
Plot 6-413:	Radiated Emissions 12 GHz – 18 GHz Horizontal Peak/Average	449
Plot 6-414:	Radiated Emissions 12 GHz – 18 GHz Vertical Peak/Average	450
Plot 6-415:	Radiated Emissions 18 GHz – 26 GHz Horizontal Peak/Average	451
Plot 6-416:	Radiated Emissions 18 GHz – 26 GHz Vertical Peak/Average	452
Plot 6-417:	Radiated Emissions of Carrier - TC #3 Fiberglass Container	453
Plot 6-418:	Radiated Emissions Transmit – 9 kHz – 150 kHz Horizontal Peak/Average	454
Plot 6-419:	Radiated Emissions Transmit – 9 kHz – 150 kHz Vertical Peak/Average	455
Plot 6-420:	Radiated Emissions Transmit – 150 kHz – 2 MHz Horizontal Peak/Average	456
Plot 6-421:	Radiated Emissions Transmit – 150 kHz – 2 MHz Vertical Peak/Average	457
Plot 6-422:	Radiated Emissions Transmit – 2 MHz – 30 MHz Horizontal Peak/Average	458
Plot 6-423:	Radiated Emissions Transmit – 2 MHz – 30 MHz Vertical Peak/Average	459
Plot 6-424:	Radiated Emissions Transmit – 30 MHz – 1 GHz Horizontal Peak/Average	460
Plot 6-425:	Radiated Emissions Transmit – 30 MHz – 1 GHz Vertical Peak/Average	461
Plot 6-426:	Radiated Emissions 1 GHz – 2 GHz Horizontal Peak/Average	462
Plot 6-427:	Radiated Emissions 1 GHz – 2 GHz Vertical Peak/Average	463
Plot 6-428:	Radiated Emissions 2 GHz – 4 GHz Horizontal Peak/Average	464
Plot 6-429:	Radiated Emissions 2 GHz – 4 GHz Vertical Peak/Average	465
Plot 6-430:	Radiated Emissions 4 GHz – 8 GHz Horizontal Peak/Average	466
Plot 6-431:	Radiated Emissions 4 GHz – 8 GHz Vertical Peak/Average	467
Plot 6-432:	Radiated Emissions 8 GHz – 12 GHz Horizontal Peak/Average	468
Plot 6-433:	Radiated Emissions 8 GHz – 12 GHz Vertical Peak/Average	469
Plot 6-434:	Radiated Emissions 12 GHz – 18 GHz Horizontal Peak/Average	470
Plot 6-435:	Radiated Emissions 12 GHz – 18 GHz Vertical Peak/Average	471
Plot 6-436:	Radiated Emissions 18 GHz – 26 GHz Horizontal Peak/Average	472
Plot 6-437:	Radiated Emissions 18 GHz – 26 GHz Vertical Peak/Average	473
Plot 6-438:	Radiated Emissions of Carrier - TC #4 Fiberglass Container	474
Plot 6-439:	Radiated Emissions Transmit – 9 kHz – 150 kHz Horizontal Peak/Average	475
Plot 6-440:	Radiated Emissions Transmit – 9 kHz – 150 kHz Vertical Peak/Average	476
Plot 6-441:	Radiated Emissions Transmit – 150 kHz – 2 MHz Horizontal Peak/Average	477
Plot 6-442:	Radiated Emissions Transmit – 150 kHz – 2 MHz Vertical Peak/Average	478
Plot 6-443:	Radiated Emissions Transmit – 2 MHz – 30 MHz Horizontal Peak/Average	479
Plot 6-444:	Radiated Emissions Transmit – 2 MHz – 30 MHz Vertical Peak/Average	480
Plot 6-445:	Radiated Emissions Transmit – 30 MHz – 1 GHz Horizontal Peak/Average	481
Plot 6-446:	Radiated Emissions Transmit – 30 MHz – 1 GHz Vertical Peak/Average	482
Plot 6-447:	Radiated Emissions 1 GHz – 2 GHz Horizontal Peak/Average	483
Plot 6-448:	Radiated Emissions 1 GHz – 2 GHz Vertical Peak/Average	484
Plot 6-449:	Radiated Emissions 2 GHz – 4 GHz Horizontal Peak/Average	485
Plot 6-450:	Radiated Emissions 2 GHz – 4 GHz Vertical Peak/Average	486
Plot 6-451:	Radiated Emissions 4 GHz – 8 GHz Horizontal Peak/Average	487
Plot 6-452:	Radiated Emissions 4 GHz – 8 GHz Vertical Peak/Average	488

Plot 6-453:	Radiated Emissions 8 GHz – 12 GHz Horizontal Peak/Average	489
Plot 6-454:	Radiated Emissions 8 GHz – 12 GHz Vertical Peak/Average	490
Plot 6-455:	Radiated Emissions 12 GHz – 18 GHz Horizontal Peak/Average	491
Plot 6-456:	Radiated Emissions 12 GHz – 18 GHz Vertical Peak/Average	492
Plot 6-457:	Radiated Emissions 18 GHz – 26 GHz Horizontal Peak/Average	493
Plot 6-458:	Radiated Emissions 18 GHz – 26 GHz Vertical Peak/Average	494
Plot 6-459:	Radiated Emissions of Carrier - TC #5 Fiberglass Container	495
Plot 6-460:	Radiated Emissions Transmit – 9 kHz – 150 kHz Horizontal Peak/Average	496
Plot 6-461:	Radiated Emissions Transmit – 9 kHz – 150 kHz Vertical Peak/Average	497
Plot 6-462:	Radiated Emissions Transmit – 150 kHz – 2 MHz Horizontal Peak/Average	498
Plot 6-463:	Radiated Emissions Transmit – 150 kHz – 2 MHz Vertical Peak/Average	499
Plot 6-464:	Radiated Emissions Transmit – 2 MHz – 30 MHz Horizontal Peak/Average	500
Plot 6-465:	Radiated Emissions Transmit – 2 MHz – 30 MHz Vertical Peak/Average	501
Plot 6-466:	Radiated Emissions Transmit – 30 MHz – 1 GHz Horizontal Peak/Average	502
Plot 6-467:	Radiated Emissions Transmit – 30 MHz – 1 GHz Vertical Peak/Average	503
Plot 6-468:	Radiated Emissions 1 GHz – 2 GHz Horizontal Peak/Average	504
Plot 6-469:	Radiated Emissions 1 GHz – 2 GHz Vertical Peak/Average	505
Plot 6-470:	Radiated Emissions 2 GHz – 4 GHz Horizontal Peak/Average	506
Plot 6-471:	Radiated Emissions 2 GHz – 4 GHz Vertical Peak/Average	507
Plot 6-472:	Radiated Emissions 4 GHz – 8 GHz Horizontal Peak/Average	508
Plot 6-473:	Radiated Emissions 4 GHz – 8 GHz Vertical Peak/Average	509
Plot 6-474:	Radiated Emissions 8 GHz – 12 GHz Horizontal Peak/Average	510
Plot 6-475:	Radiated Emissions 8 GHz – 12 GHz Vertical Peak/Average	511
Plot 6-476:	Radiated Emissions 12 GHz – 18 GHz Horizontal Peak/Average	512
Plot 6-477:	Radiated Emissions 12 GHz – 18 GHz Vertical Peak/Average	513
Plot 6-478:	Radiated Emissions 18 GHz – 26 GHz Horizontal Peak/Average	514
Plot 6-479:	Radiated Emissions 18 GHz – 26 GHz Vertical Peak/Average	515
Plot 6-480:	Radiated Emissions of Carrier - TC #6 Fiberglass Container	516
Plot 6-481:	Radiated Emissions Transmit – 9 kHz – 150 kHz Horizontal Peak/Average	517
Plot 6-482:	Radiated Emissions Transmit – 9 kHz – 150 kHz Vertical Peak/Average	518
Plot 6-483:	Radiated Emissions Transmit – 150 kHz – 2 MHz Horizontal Peak/Average	519
Plot 6-484:	Radiated Emissions Transmit – 150 kHz – 2 MHz Vertical Peak/Average	520
Plot 6-485:	Radiated Emissions Transmit – 2 MHz – 30 MHz Horizontal Peak/Average	521
Plot 6-486:	Radiated Emissions Transmit – 2 MHz – 30 MHz Vertical Peak/Average	522
Plot 6-487:	Radiated Emissions Transmit – 30 MHz – 1 GHz Horizontal Peak/Average	523
Plot 6-488:	Radiated Emissions Transmit – 30 MHz – 1 GHz Vertical Peak/Average	524
Plot 6-489:	Radiated Emissions 1 GHz – 2 GHz Horizontal Peak/Average	525
Plot 6-490:	Radiated Emissions 1 GHz – 2 GHz Vertical Peak/Average	526
Plot 6-491:	Radiated Emissions 2 GHz – 4 GHz Horizontal Peak/Average	527
Plot 6-492:	Radiated Emissions 2 GHz – 4 GHz Vertical Peak/Average	528
Plot 6-493:	Radiated Emissions 4 GHz – 8 GHz Horizontal Peak/Average	529
Plot 6-494:	Radiated Emissions 4 GHz – 8 GHz Vertical Peak/Average	530
Plot 6-495:	Radiated Emissions 8 GHz – 12 GHz Horizontal Peak/Average	531
Plot 6-496:	Radiated Emissions 8 GHz – 12 GHz Vertical Peak/Average	532
Plot 6-497:	Radiated Emissions 12 GHz – 18 GHz Horizontal Peak/Average	533
Plot 6-498:	Radiated Emissions 12 GHz – 18 GHz Vertical Peak/Average	534
Plot 6-499:	Radiated Emissions 18 GHz – 26 GHz Horizontal Peak/Average	535
Plot 6-500:	Radiated Emissions 18 GHz – 26 GHz Vertical Peak/Average	536
Plot 6-501:	Radiated Emissions of Carrier - TC #7 Fiberglass Container	537
Plot 6-502:	Radiated Emissions Transmit – 9 kHz – 150 kHz Horizontal Peak/Average	538
Plot 6-503:	Radiated Emissions Transmit – 9 kHz – 150 kHz Vertical Peak/Average	539
Plot 6-504:	Radiated Emissions Transmit – 150 kHz – 2 MHz Horizontal Peak/Average	540
Plot 6-505:	Radiated Emissions Transmit – 150 kHz – 2 MHz Vertical Peak/Average	541
Plot 6-506:	Radiated Emissions Transmit – 2 MHz – 30 MHz Horizontal Peak/Average	542
Plot 6-507:	Radiated Emissions Transmit – 2 MHz – 30 MHz Vertical Peak/Average	543
Plot 6-508:	Radiated Emissions Transmit – 30 MHz – 1 GHz Horizontal Peak/Average	544

Plot 6-509:	Radiated Emissions Transmit – 30 MHz – 1 GHz Vertical Peak/Average	545
Plot 6-510:	Radiated Emissions 1 GHz – 2 GHz Horizontal Peak/Average	546
Plot 6-511:	Radiated Emissions 1 GHz – 2 GHz Vertical Peak/Average	547
Plot 6-512:	Radiated Emissions 2 GHz – 4 GHz Horizontal Peak/Average	548
Plot 6-513:	Radiated Emissions 2 GHz – 4 GHz Vertical Peak/Average	549
Plot 6-514:	Radiated Emissions 4 GHz – 8 GHz Horizontal Peak/Average	550
Plot 6-515:	Radiated Emissions 4 GHz – 8 GHz Vertical Peak/Average	551
Plot 6-516:	Radiated Emissions 8 GHz – 12 GHz Horizontal Peak/Average	552
Plot 6-517:	Radiated Emissions 8 GHz – 12 GHz Vertical Peak/Average	553
Plot 6-518:	Radiated Emissions 12 GHz – 18 GHz Horizontal Peak/Average	554
Plot 6-519:	Radiated Emissions 12 GHz – 18 GHz Vertical Peak/Average	555
Plot 6-520:	Radiated Emissions 18 GHz – 26 GHz Horizontal Peak/Average	556
Plot 6-521:	Radiated Emissions 18 GHz – 26 GHz Vertical Peak/Average	557
Plot 6-522:	Radiated Emissions of Carrier - TC #8 Fiberglass Container	558
Plot 6-523:	Radiated Emissions Transmit – 9 kHz – 150 kHz Horizontal Peak/Average	559
Plot 6-524:	Radiated Emissions Transmit – 9 kHz – 150 kHz Vertical Peak/Average	560
Plot 6-525:	Radiated Emissions Transmit – 150 kHz – 2 MHz Horizontal Peak/Average	561
Plot 6-526:	Radiated Emissions Transmit – 150 kHz – 2 MHz Vertical Peak/Average	562
Plot 6-527:	Radiated Emissions Transmit – 2 MHz – 30 MHz Horizontal Peak/Average	563
Plot 6-528:	Radiated Emissions Transmit – 2 MHz – 30 MHz Vertical Peak/Average	564
Plot 6-529:	Radiated Emissions Transmit – 30 MHz – 1 GHz Horizontal Peak/Average	565
Plot 6-530:	Radiated Emissions Transmit – 30 MHz – 1 GHz Vertical Peak/Average	566
Plot 6-531:	Radiated Emissions 1 GHz – 2 GHz Horizontal Peak/Average	567
Plot 6-532:	Radiated Emissions 1 GHz – 2 GHz Vertical Peak/Average	568
Plot 6-533:	Radiated Emissions 2 GHz – 4 GHz Horizontal Peak/Average	569
Plot 6-534:	Radiated Emissions 2 GHz – 4 GHz Vertical Peak/Average	570
Plot 6-535:	Radiated Emissions 4 GHz – 8 GHz Horizontal Peak/Average	571
Plot 6-536:	Radiated Emissions 4 GHz – 8 GHz Vertical Peak/Average	572
Plot 6-537:	Radiated Emissions 8 GHz – 12 GHz Horizontal Peak/Average	573
Plot 6-538:	Radiated Emissions 8 GHz – 12 GHz Vertical Peak/Average	574
Plot 6-539:	Radiated Emissions 12 GHz – 18 GHz Horizontal Peak/Average	575
Plot 6-540:	Radiated Emissions 12 GHz – 18 GHz Vertical Peak/Average	576
Plot 6-541:	Radiated Emissions 18 GHz – 26 GHz Horizontal Peak/Average	577
Plot 6-542:	Radiated Emissions 18 GHz – 26 GHz Vertical Peak/Average	578
Plot 6-543:	Radiated Emissions of Carrier - TC #9 Fiberglass Container	579
Plot 6-544:	Radiated Emissions Transmit – 9 kHz – 150 kHz Horizontal Peak/Average	580
Plot 6-545:	Radiated Emissions Transmit – 9 kHz – 150 kHz Vertical Peak/Average	581
Plot 6-546:	Radiated Emissions Transmit – 150 kHz – 2 MHz Horizontal Peak/Average	582
Plot 6-547:	Radiated Emissions Transmit – 150 kHz – 2 MHz Vertical Peak/Average	583
Plot 6-548:	Radiated Emissions Transmit – 2 MHz – 30 MHz Horizontal Peak/Average	584
Plot 6-549:	Radiated Emissions Transmit – 2 MHz – 30 MHz Vertical Peak/Average	585
Plot 6-550:	Radiated Emissions Transmit – 30 MHz – 1 GHz Horizontal Peak/Average	586
Plot 6-551:	Radiated Emissions Transmit – 30 MHz – 1 GHz Vertical Peak/Average	587
Plot 6-552:	Radiated Emissions 1 GHz – 2 GHz Horizontal Peak/Average	588
Plot 6-553:	Radiated Emissions 1 GHz – 2 GHz Vertical Peak/Average	589
Plot 6-554:	Radiated Emissions 2 GHz – 4 GHz Horizontal Peak/Average	590
Plot 6-555:	Radiated Emissions 2 GHz – 4 GHz Vertical Peak/Average	591
Plot 6-556:	Radiated Emissions 4 GHz – 8 GHz Horizontal Peak/Average	592
Plot 6-557:	Radiated Emissions 4 GHz – 8 GHz Vertical Peak/Average	593
Plot 6-558:	Radiated Emissions 8 GHz – 12 GHz Horizontal Peak/Average	594
Plot 6-559:	Radiated Emissions 8 GHz – 12 GHz Vertical Peak/Average	595
Plot 6-560:	Radiated Emissions 12 GHz – 18 GHz Horizontal Peak/Average	596
Plot 6-561:	Radiated Emissions 12 GHz – 18 GHz Vertical Peak/Average	597
Plot 6-562:	Radiated Emissions 18 GHz – 26 GHz Horizontal Peak/Average	598
Plot 6-563:	Radiated Emissions 18 GHz – 26 GHz Vertical Peak/Average	599

Table of Figures

Figure 2-1: Configuration of Tested System	29
--	----

Table of Photographs

Photograph 1: Test Configuration #1 (TC #1)	19
Photograph 2: Test Configuration #2 (TC #2)	20
Photograph 3: Test Configuration #3 (TC #3)	21
Photograph 4: Test Configuration #4 (TC #4)	22
Photograph 5: Test Configuration #5 (TC #5)	23
Photograph 6: Test Configuration #6 (TC #6)	24
Photograph 7: Test Configuration #7 (TC #7)	25
Photograph 8: Test Configuration #8 (TC #8)	26
Photograph 9: Test Configuration #9 (TC #9)	27
Photograph 10: EUT in Swivel Holder	28
Photograph 11: Conducted Emissions – TC #1, Front View	602
Photograph 12: Conducted Emissions – TC #1, Rear View	603
Photograph 13: Radiated Emissions – TC #1; Steel Container, Front View	604
Photograph 14: Radiated Emissions – TC #1; Steel Container, Rear View	605
Photograph 15: Radiated Emissions – TC #2; Steel Container, Front View	606
Photograph 16: Radiated Emissions – TC #2; Steel Container, Rear View	607
Photograph 17: Radiated Emissions – TC #3; Steel Container, Front View	608
Photograph 18: Radiated Emissions – TC #3; Steel Container, Rear View	609
Photograph 19: Radiated Emissions – TC #4; Steel Container, Front View	610
Photograph 20: Radiated Emissions – TC #4; Steel Container, Rear View	611
Photograph 21: Radiated Emissions – TC #5; Steel Container, Front View	612
Photograph 22: Radiated Emissions – TC #5; Steel Container, Rear View	613
Photograph 23: Radiated Emissions – TC #6; Steel Container, Front View	614
Photograph 24: Radiated Emissions – TC #6; Steel Container, Rear View	615
Photograph 25: Radiated Emissions – TC #7; Steel Container, Front View	616
Photograph 26: Radiated Emissions – TC #7; Steel Container, Rear View	617
Photograph 27: Radiated Emissions – TC #8; Steel Container, Front View	618
Photograph 28: Radiated Emissions – TC #8; Steel Container, Rear View	619
Photograph 29: Radiated Emissions – TC #9; Steel Container, Front View	620
Photograph 30: Radiated Emissions – TC #9; Steel Container, Rear View	621
Photograph 31: Radiated Emissions – TC #1; Concrete Container, Front View	622
Photograph 32: Radiated Emissions – TC #1; Concrete Container, Rear View	623
Photograph 33: Radiated Emissions – TC #2; Concrete Container, Front View	624
Photograph 34: Radiated Emissions – TC #2; Concrete Container, Rear View	625
Photograph 35: Radiated Emissions – TC #3; Concrete Container, Front View	626
Photograph 36: Radiated Emissions – TC #3; Concrete Container, Rear View	627
Photograph 37: Radiated Emissions – TC #4; Concrete Container, Front View	628
Photograph 38: Radiated Emissions – TC #4; Concrete Container, Rear View	629
Photograph 39: Radiated Emissions – TC #5; Concrete Container, Front View	630
Photograph 40: Radiated Emissions – TC #5; Concrete Container, Rear View	631
Photograph 41: Radiated Emissions – TC #6; Concrete Container, Front View	632
Photograph 42: Radiated Emissions – TC #6; Concrete Container, Rear View	633
Photograph 43: Radiated Emissions – TC #7; Concrete Container, Front View	634
Photograph 44: Radiated Emissions – TC #7; Concrete Container, Rear View	635
Photograph 45: Radiated Emissions – TC #8; Concrete Container, Front View	636
Photograph 46: Radiated Emissions – TC #8; Concrete Container, Rear View	637
Photograph 47: Radiated Emissions – TC #9; Concrete Container, Front View	638
Photograph 48: Radiated Emissions – TC #9; Concrete Container, Rear View	639

Photograph 49: Radiated Emissions – TC #1; Fiberglass Container, Front View.....	640
Photograph 50: Radiated Emissions – TC #1; Fiberglass Container, Rear View	641
Photograph 51: Radiated Emissions – TC #2; Fiberglass Container, Front View.....	642
Photograph 52: Radiated Emissions – TC #2; Fiberglass Container, Rear View	643
Photograph 53: Radiated Emissions – TC #3; Fiberglass Container, Front View.....	644
Photograph 54: Radiated Emissions – TC #3; Fiberglass Container, Rear View	645
Photograph 55: Radiated Emissions – TC #4; Fiberglass Container, Front View.....	646
Photograph 56: Radiated Emissions – TC #4; Fiberglass Container, Rear View	647
Photograph 57: Radiated Emissions – TC #5; Fiberglass Container, Front View.....	648
Photograph 58: Radiated Emissions – TC #5; Fiberglass Container, Rear View	649
Photograph 59: Radiated Emissions – TC #6; Fiberglass Container, Front View.....	650
Photograph 60: Radiated Emissions – TC #6; Fiberglass Container, Rear View	651
Photograph 61: Radiated Emissions – TC #7; Fiberglass Container, Front View.....	652
Photograph 62: Radiated Emissions – TC #7; Fiberglass Container, Rear View	653
Photograph 63: Radiated Emissions – TC #8; Fiberglass Container, Front View.....	654
Photograph 64: Radiated Emissions – TC #8; Fiberglass Container, Rear View	655
Photograph 65: Radiated Emissions – TC #9; Fiberglass Container, Front View.....	656
Photograph 66: Radiated Emissions – TC #9; Fiberglass Container, Rear View	657

1 General Information

1.1 Scope

The following Type Certification Report is prepared on behalf of Vega Grieshaber KG in accordance with the Federal Communications Commission and Industry Canada Rules and Regulations. The Equipment Under Test (EUT) was Model PS60S, Level Probing Radar, FCC ID: O6QPS60XS2, IC: 3892A-PS60XS2, tested with nine different antennas.

The EUT is available with two different electronics units:

- 1) HART (PS60HS)
- 2) PA and FF (PS60PAS and PS60FFS)

The worst case emissions are found with the HART electronics unit (PS60HS) implemented in the EUT.

The test results reported in this document relate only to the items tested.

All measurements contained in this application were conducted in accordance with FCC Rules and Regulations CFR 47, and ANSI C63.10 American National Standard of Procedures for Compliance Testing of Unlicensed Wireless Devices. 2013. The instrumentation utilized for the measurements conforms to the ANSI C63.4 standard for EMI and Field Strength Instrumentation. Calibration checks are performed regularly on the instruments, and all accessories including high pass filter, coaxial attenuator, preamplifier and cables.

1.2 Test Facility

The open area test site and conducted measurement facility used to collect the radiated data is located on the parking lot of Rhein Tech Laboratories, Inc., 360 Herndon Parkway, Suite 1400, Herndon, Virginia 20170. This site has been fully described in a report submitted to and approved by the Federal Communications Commission to perform AC line conducted and radiated emissions testing.

1.3 Related Submittal(s)/Grant(s)

This is an original FCC §15.209/IC RSS-211 application report to support a composite application.

Vega Grieshaber KG submitted justification to IC, and received their approval, for tilted installation for in-tank measurements, provided the assessment includes compliant in-tank measurements with tilted installation and follows the test guidance in ETSI EN 302 372. A copy of the approved justification, and IC's response, was submitted with this application.

1.4 Modifications

None.

2 Tested System Details

The test sample was received on May 2, 2015. Listed below are the identifiers and descriptions of all equipment, cables, and internal devices used with the EUT for this testing, as applicable.

Table 2-1: Equipment under Test (EUT)

Part	Manufacturer	Model (HVIN)	Serial Number	FCC ID	Cable Type	RTL Bar Code
UXBXCHKMAX	VEGA Grieshaber KG	PS60S	27522102	O6QPS60XS2	N/A	21455
UXDND2HKMAX	VEGA Grieshaber KG	PS60S	27522103	O6QPS60XS2	N/A	21456
UXKND2HKMAX	VEGA Grieshaber KG	PS60S	27522104	O6QPS60XS2	N/A	21457
UXNCCHKMAX	VEGA Grieshaber KG	PS60S	27522105	O6QPS60XS2	N/A	21458
75mm Filled Horn Antenna (23.6 dBi)	VEGA Grieshaber KG	N/A	N/A	N/A	N/A	21138
75mm Plastic Horn Antenna (24.8 dBi)	VEGA Grieshaber KG	N/A	N/A	N/A	N/A	21140
40mm Horn Antenna (19.5 dBi)	VEGA Grieshaber KG	N/A	N/A	N/A	N/A	21910
48mm Horn Antenna (21.5 dBi)	VEGA Grieshaber KG	N/A	N/A	N/A	N/A	21911
75mm Horn Antenna (24.5 dBi)	VEGA Grieshaber KG	N/A	N/A	N/A	N/A	21137
95mm Horn Antenna (27.0 dBi)	VEGA Grieshaber KG	N/A	N/A	N/A	N/A	21136
245mm Parabolic Dish (32.8)	VEGA Grieshaber KG	N/A	N/A	N/A	N/A	21904
48mm Filled Horn Antenna (19.8 dBi)	VEGA Grieshaber KG	N/A	N/A	N/A	N/A	21909
40mm Encapsulated Horn Antenna (19.6 dBi)	VEGA Grieshaber KG	N/A	N/A	N/A	N/A	21912
DC Power Supply	Hewlett Packard	6024A	1912A00331	N/A	1m un- shielded	901635

2.1 Test Configurations

The EUT was tested in the following configurations, and the test data is included in this report. The appropriate test configuration numbers (TC #1, TC #2, TC #3, TC #4, TC #5, TC #6, TC #7, TC#8, or TC #9) are provided with the test data.

Table 2-2: Test Configuration #1 (TC #1)

Part	Model (HVIN)	Manufacturer	Cable Type	RTL Bar Code
UXBXCHKMAX	PS60S	VEGA Grieshaber KG	N/A	21455
Electronics	PS60HS	VEGA Grieshaber KG	N/A	21141
75mm Plastic Horn Antenna (24.8 dBi)	N/A	VEGA Grieshaber KG	N/A	21140

Photograph 1: Test Configuration #1 (TC #1)



Table 2-3: Test Configuration #2 (TC #2)

Part	Model	Manufacturer	Cable Type	RTL Bar Code
UXDND2HKMAX	PS60S	VEGA Grieshaber KG	N/A	21456
Electronics	PS60HS	VEGA Grieshaber KG	N/A	21141
40mm Horn Antenna (19.5 dBi)	N/A	VEGA Grieshaber KG	N/A	21910

Photograph 2: Test Configuration #2 (TC #2)



Table 2-4: Test Configuration #3 (TC #3)

Part	Model	Manufacturer	Cable Type	RTL Bar Code
UXKND2HKMAX	PS60S	VEGA Grieshaber KG	N/A	21457
Electronics	PS60HS	VEGA Grieshaber KG	N/A	21141
48mm Horn Antenna (21.5 dBi)	N/A	VEGA Grieshaber KG	N/A	21911

Photograph 3: Test Configuration #3 (TC #3)



Table 2-5: Test Configuration #4 (TC #4)

Part	Model	Manufacturer	Cable Type	RTL Bar Code
UXKND2HKMAX	PS60S	VEGA Grieshaber KG	N/A	21457
Electronics	PS60HS	VEGA Grieshaber KG	N/A	21141
75mm Horn Antenna (24.5 dBi)	N/A	VEGA Grieshaber KG	N/A	21137

Photograph 4: Test Configuration #4 (TC #4)



Table 2-6: Test Configuration #5 (TC #5)

Part	Model	Manufacturer	Cable Type	RTL Bar Code
UXKND2HKMAX	PS60S	VEGA Grieshaber KG	N/A	21457
Electronics	PS60HS	VEGA Grieshaber KG	N/A	21141
95mm Horn Antenna (27.0 dBi)	N/A	VEGA Grieshaber KG	N/A	21136

Photograph 5: Test Configuration #5 (TC #5)



Table 2-7: Test Configuration #6 (TC #6)

Part	Model	Manufacturer	Cable Type	RTL Bar Code
UXKND2HKMAX	PS60S	VEGA Grieshaber KG	N/A	21457
Electronics	PS60HS	VEGA Grieshaber KG	N/A	21141
245mm Parabolic Dish Antenna (32.8 dBi)	N/A	VEGA Grieshaber KG	N/A	21904

Photograph 6: Test Configuration #6 (TC #6)



Table 2-8: Test Configuration #7 (TC #7)

Part	Model	Manufacturer	Cable Type	RTL Bar Code
UXNCCHKMAX	PS60S	VEGA Grieshaber KG	N/A	21458
Electronics	PS60HS	VEGA Grieshaber KG	N/A	21141
48mm Filled Horn Antenna (19.8 dBi)	N/A	VEGA Grieshaber KG	N/A	21909

Photograph 7: Test Configuration #7 (TC #7)



Table 2-9: Test Configuration #8 (TC #8)

Part	Model	Manufacturer	Cable Type	RTL Bar Code
UXBXCHKMAX	PS60S	VEGA Grieshaber KG	N/A	21455
Electronics	PS60HS	VEGA Grieshaber KG	N/A	21141
40mm Encapsulated Horn Antenna (19.6 dBi)	N/A	VEGA Grieshaber KG	N/A	21912

Photograph 8: Test Configuration #8 (TC #8)



Table 2-10: Test Configuration #9 (TC #9)

Part	Model (HVIN)	Manufacturer	Cable Type	RTL Bar Code
UXNCCHKMAX	PS60S	VEGA Grieshaber KG	N/A	21458
Electronics	PS60HS	VEGA Grieshaber KG	N/A	21141
75mm Filled Horn Antenna (23.6 dBi)	N/A	VEGA Grieshaber KG	N/A	21138

Photograph 9: Test Configuration #9 (TC #9)



Photograph 10: EUT in Swivel Holder



Figure 2-1: Configuration of Tested System

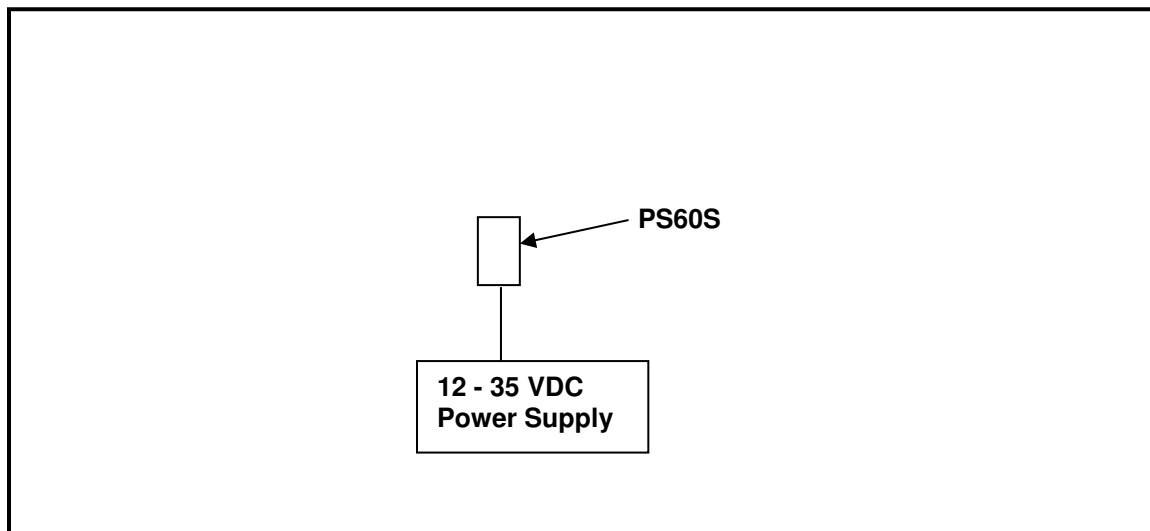

3 Test Distance and Exercising the EUT

The EUT's normal operating measurement mode is transmitting 2 pulses every second continuously. In measurement mode, the EUT maintains its full power. The EUT's spurious emissions were investigated and tested in the restricted and non-restricted bands from 9 kHz to 100 GHz at 3 meters. Furthermore, test antenna handheld measurements were performed in and around the EUT to determine radiated emissions emanating from the EUT since it was mounted on metal, concrete and fiberglass containers such that its main beam was enclosed and perpendicularly pointing downwards.

All measurements above 1 GHz were performed at an antenna–EUT test distance of 0.1 meter with the test antenna polarized horizontally and vertically to determine the EUT's worst-case emissions. The measurement results were then corrected to the 3-meter limit. Measurements below 1 GHz were performed at an antenna distance of 3 meters on the EUT as a digital interface device. The EUT was tested with its main beam pointing vertically downward within steel, reinforced concrete and reinforced fiberglass enclosed containers.

Furthermore, all antennas were also investigated with the tilt bracket attached and positioned at the maximum tilt angle during the in-tank, LPR-installed radiated emissions measurements. However, there were no discernible differences between the main beam pointing vertically downward radiated emissions measured data and the tilt bracket (max tilt angle) radiated emissions measured data; as such the worst-case radiated emissions data with the main beam pointing vertically downward is presented in the report.

Rohde & Schwartz FSU 50 spectrum analyzer and Rohde & Schwartz harmonic mixers were used for testing the EUT. The analyzer has functions and routines that distinguish ghost images from real images. Furthermore, RTL engineers have been thoroughly trained by Rohde & Schwartz to use the spectrum analyzer and mixers. We further attest that real measurements were made and the measurements were not masked by ghost images.

It must be noted for IC/ISED/Canada that the -41.3 dB EIRP limit required in section 5.3 of RSS-211 could not be measured for EUT with antennas configured in the metal, reinforced fiberglass and reinforced concrete tanks and tested, there were no fundamental carrier frequencies that could be measured for the RSS-211 report using the substitution method. The resolution bandwidth was reduced to 1 kHz to discern the signals, and handheld antenna measurements were performed in and around the EUT to measure the carrier with all EUT antenna. Thus, the EIRP could not be measured since the carrier is completely attenuated for the most part. The data in the report is an attempt to show the noise floor, there is hardly any carrier.

4 Conducted Limits - §15.207, IC RSS-Gen

Conducted emissions were performed on the EUT using an off-the-shelf 12-volt power supply. This was considered adequate since the EUT is used in industrial environments where industrial 12 VDC power is provided. The general conducted limit under Part 15.207 was applied. The EUT was investigated and tested with the highest gain antenna in TC #1. The antenna configuration or gain has does not have an impact on the conducted emissions data. The data below shows the worst-case emissions represents all EUT antenna configurations.

4.1 Conducted Emission Limits Test Data

4.1.1 Test Configuration #1 (TC #1)

Plot 4-1: Conducted Emissions Transmit - Phase (TC #1)

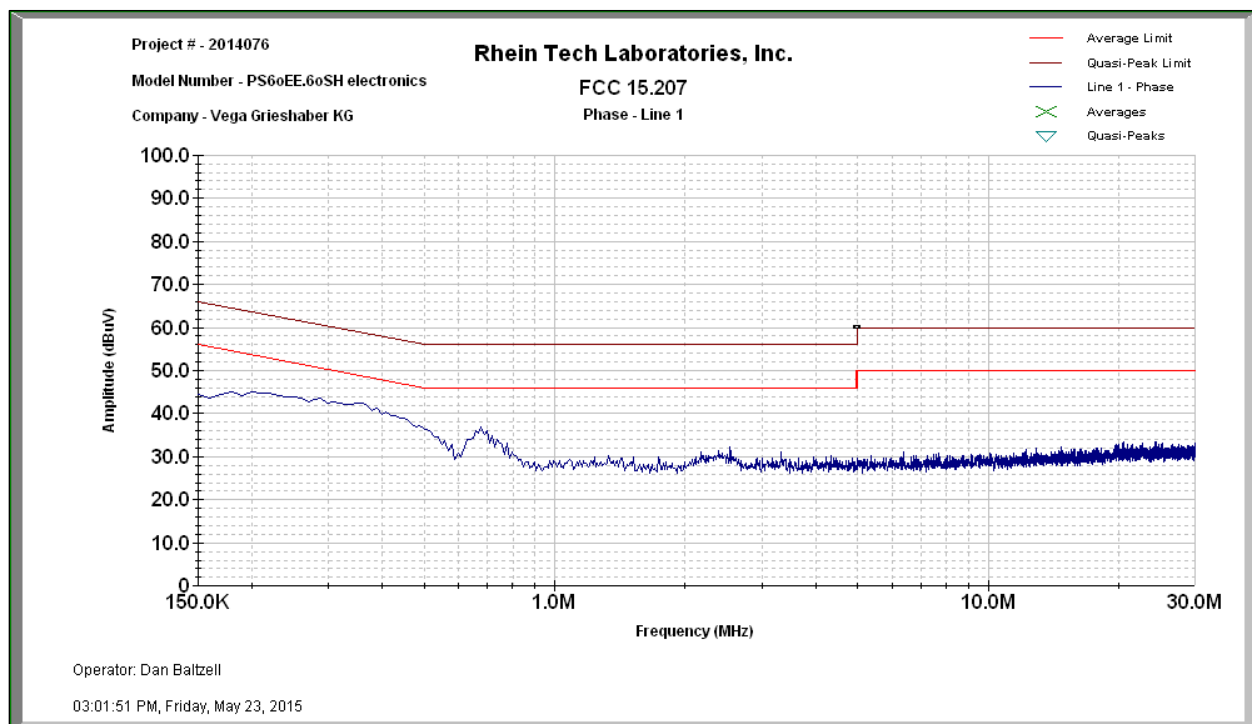

Plot 4-2: Conducted Emissions Transmit – Neutral (TC #1)

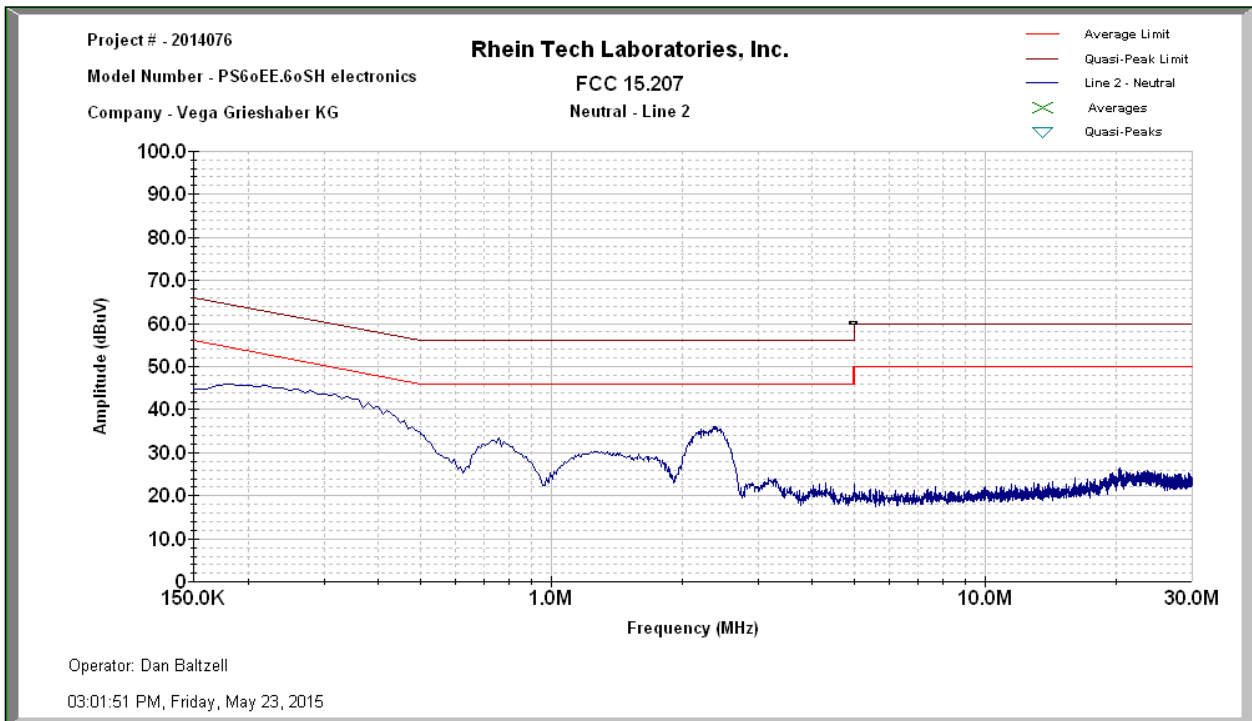

Table 4-1: Conducted Line Emissions Test Equipment

RTL Asset #	Manufacturer	Model	Part Type	Serial Number	Calibration Due Date
900968	Hewlett Packard	8567A	Spectrum Analyzer (10 kHz - 1.5 GHz)	2602A00160	2/17/16
900339	Hewlett Packard	85650A	Quasi-Peak Adapter	2521A00743	2/17/16
900970	Hewlett Packard	85662A	Spectrum Analyzer Display	2542A11239	2/17/16
901083	AFJ International	LS16	16A LISN (110 V)	16010020080	12/27/15
N/A	Rhein Tech Laboratories, Inc.	Automated Emissions Tester	Emissions Testing Software Rev. 14.0.2	N/A	N/A

Test Personnel:

Daniel W. Baltzell Test Engineer	 Signature	May 23, 2015 Date of Test
-------------------------------------	--	------------------------------

Test Personnel:

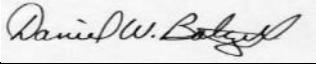
Daniel W. Baltzell Test Engineer	 Signature	October 20, 2015 Date of Test
-------------------------------------	--	----------------------------------

6 Radiated Emission Limits - §15.209, IC RSS-Gen, RSS-211 5.3

6.1 Radiated Emission Limits Test Procedure

The EUT's radiated spurious emissions, comprised of harmonic and spurious emissions that fall in the restricted and non-restricted bands, were investigated and tested from 0.009 kHz to 100 GHz in accordance with C63.10 2015. The restricted bands are listed in Part 15.205. The maximum permitted average field strength for the restricted band is listed in Part 15.209. To determine worst-case emissions, the EUT was tested while installed perpendicularly downwards in steel and concrete containers, and the EUT was rotated along its axis.

The test antenna was horizontally and vertically polarized during testing. The general limit under Part 15.209 was applied for all frequencies from 0.009 kHz to 100 GHz, per FCC 15.209. Radiated spurious emissions were detected between 9kHz MHz to 1 GHz; none were detected from 1 GHz to 100 GHz that were within 6dB of the peak or average limits. Horizontal and vertical antenna polarization radiated spurious emissions plots are provided from 9kHz to 26.5 GHz to demonstrate that the EUT has no discernable radiated spurious emissions to measure. A handheld test-antenna measurement method was also used in, around, and close to the EUT, to investigate radiated spurious emissions; no radiated spurious emissions were found, except within the authorized band of the carrier.

The EUT was investigated and tested with test configurations TC #1, TC #2, TC #3, TC #4, TC #5, TC #6, TC #7, TC #8, and TC #9 in enclosed steel, reinforced concrete and reinforced fiberglass containers. The EUT configurations TC #1, TC #2, TC #3, TC #4, TC #5, TC #6, TC #7, TC #8, and TC #9 were also investigated and tested configured with a swivel holder and installed inside the enclosed steel, reinforced concrete and reinforced fiberglass containers.

6.2 Field Strength Calculation

The field strength is calculated by adding the antenna factor and the cable factor from the measured Spectrum Analyzer reading.

Spectrum Analyzer Level Corrected (dBuV/m) = Spectrum Analyzer Level (dBuV/m) + AF (dB/m) + CL (dB);

where AF = antenna factor and CL = cable loss

6.3 Radiated Emission Limits Test Data 9 kHz – 26 GHz

6.3.1 Radiated Emissions Carrier Test Data - Steel Container

6.3.1.1 Radiated Emissions Carrier Test Data - TC#1 Steel Container

Plot 6-1: Radiated Emissions of Carrier - TC #1 Steel Container

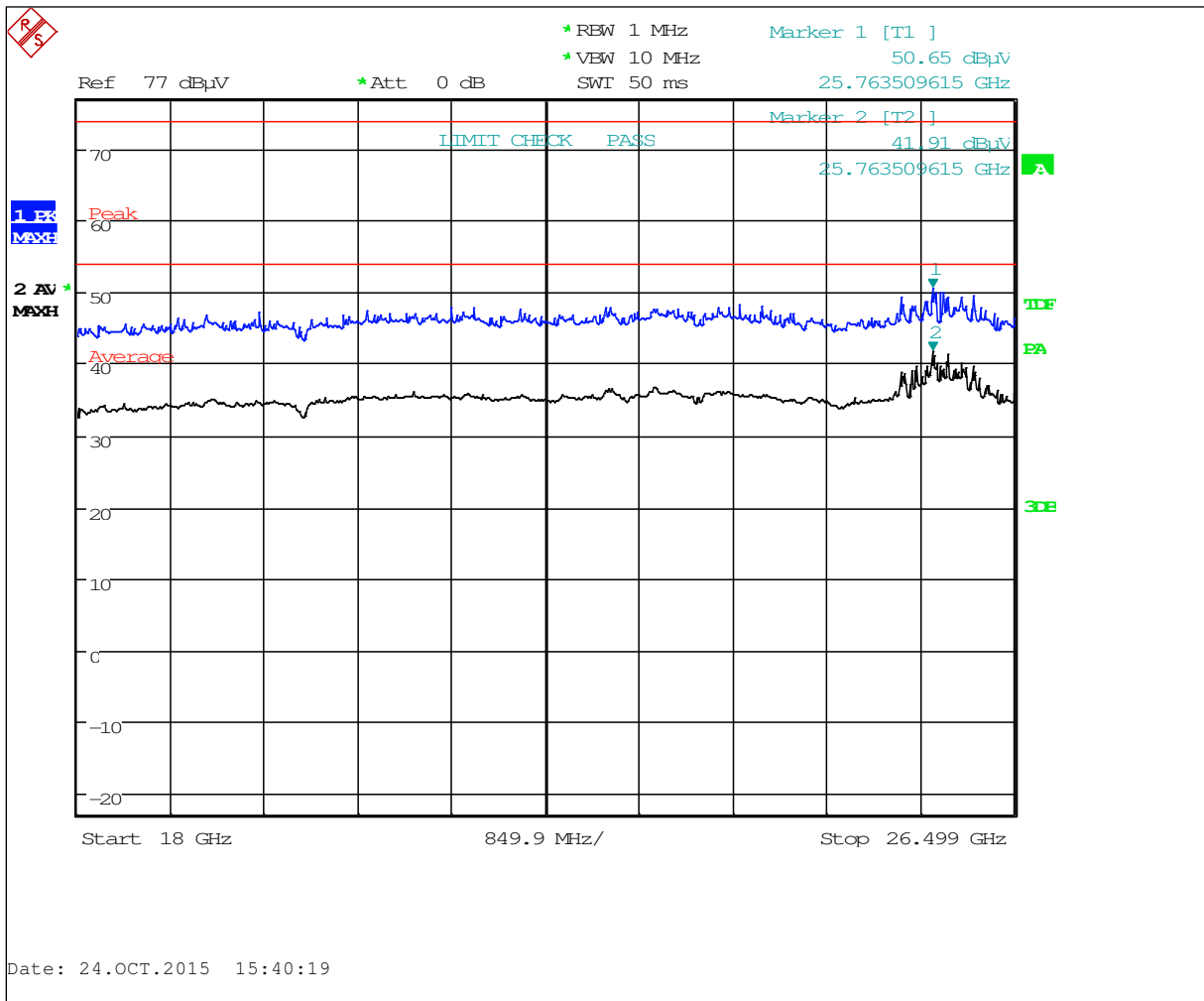
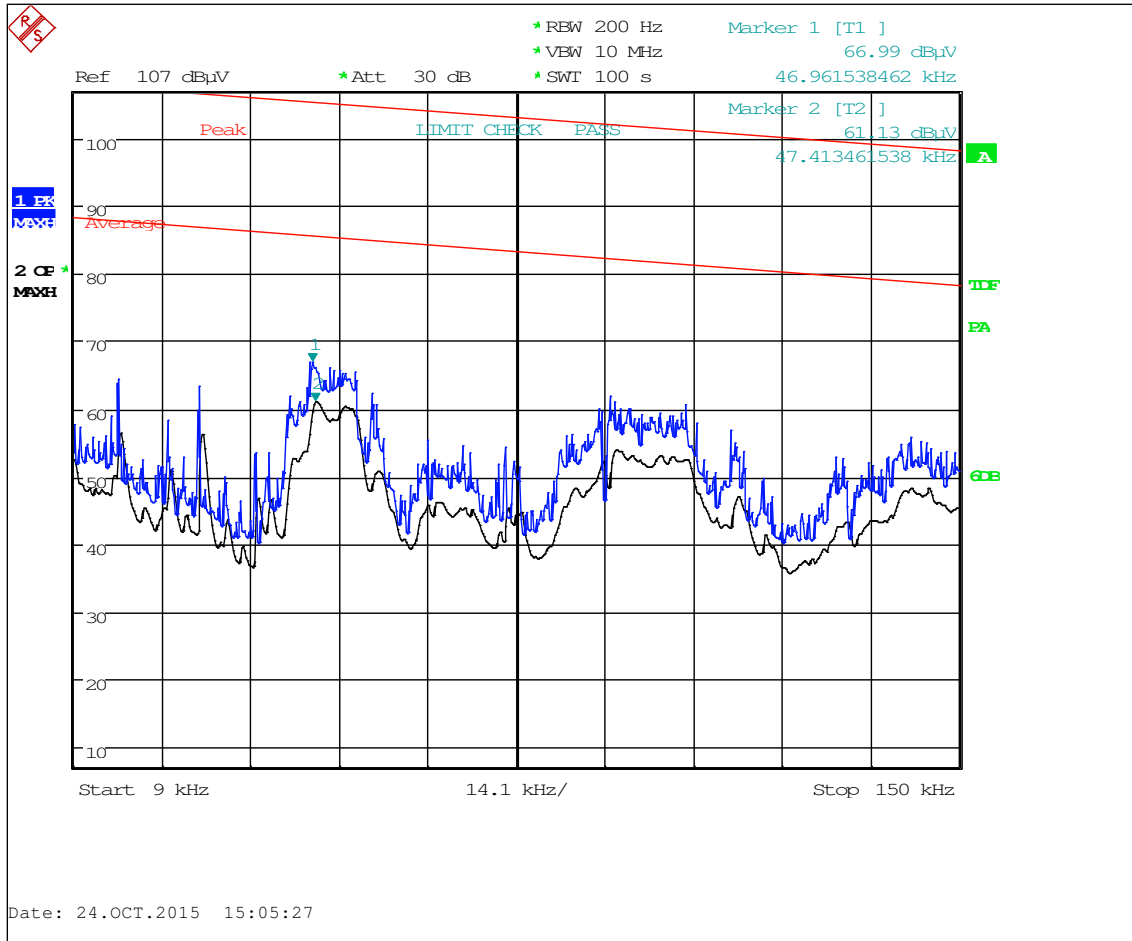

Table 6-1: Radiated Emissions of Carrier – TC #1 Steel Container

Frequency (GHz)	Detector	Test Antenna Pol	Corrected Spectrum Analyzer Level (dBuV/m)	FCC Limit (dBuV)	Margin (dB)	Corrected Spectrum Analyzer Level (dBm/MHz)	IC Limit (dBm/MHz)	Margin (dBm)
25.7635	Peak	H	50.7	74.0	-23.3		NA	
25.7635	Average	H	41.9	54.0	-12.1	-53.3	-41.3	12.0

6.3.1.2 Radiated Emissions Below 1 GHz Test Data – TC#1 Steel Container

Plot 6-2: Radiated Emissions Transmit – 9 kHz – 150 kHz Horizontal Peak/Average



Plot 6-3: Radiated Emissions Transmit – 9 kHz – 150 kHz Vertical Peak/Average

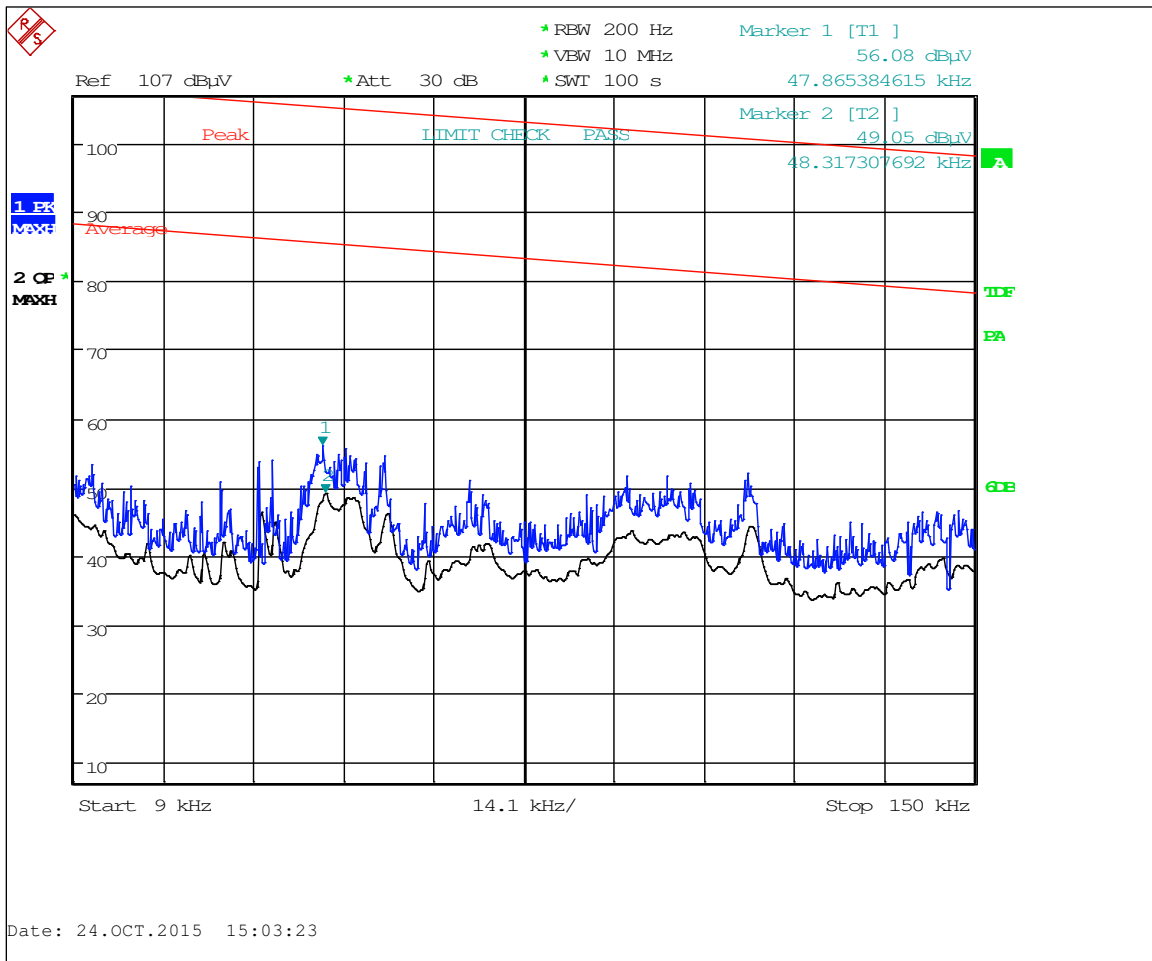

Plot 6-4: Radiated Emissions Transmit – 150 kHz – 2 MHz Horizontal Peak/Average

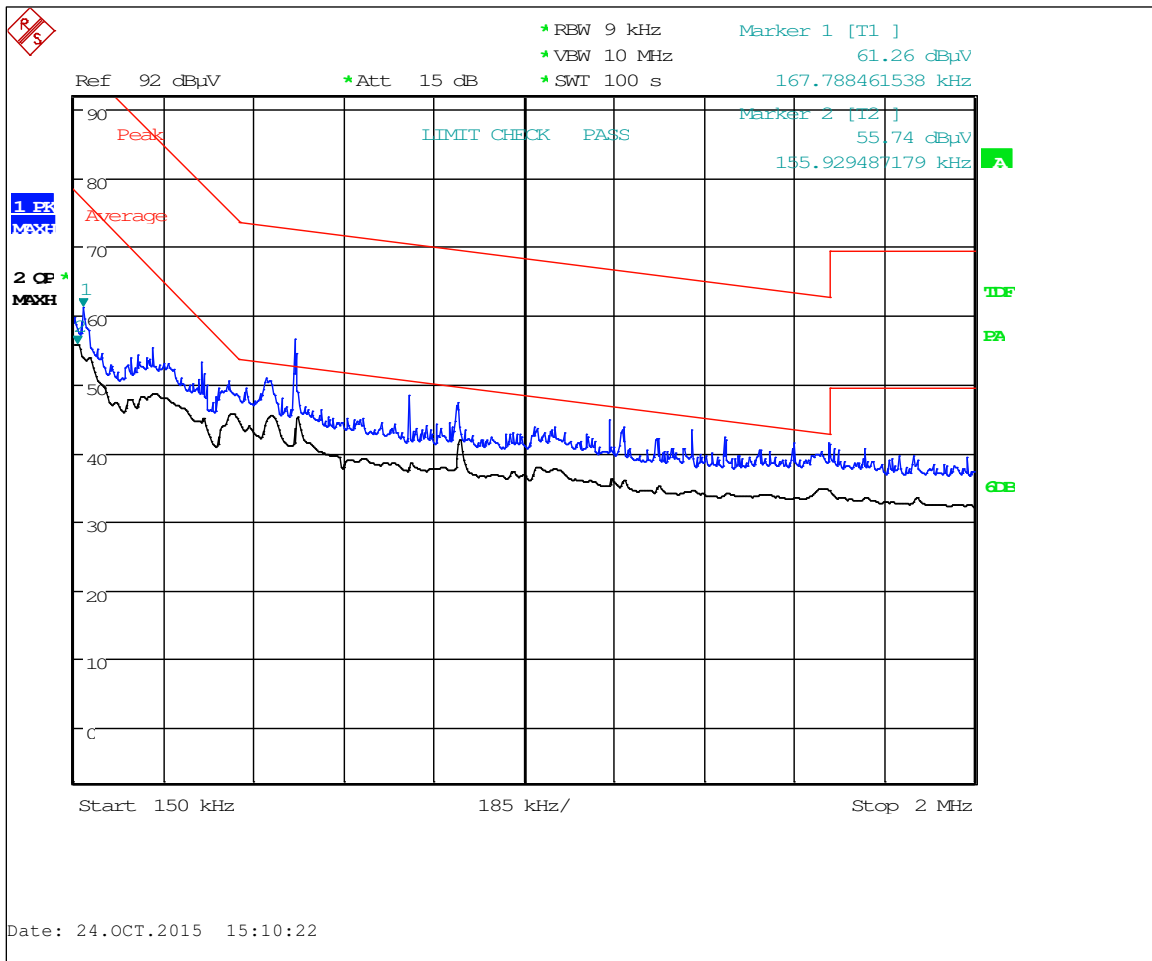

Plot 6-5: Radiated Emissions Transmit – 150 kHz – 2 MHz Vertical Peak/Average

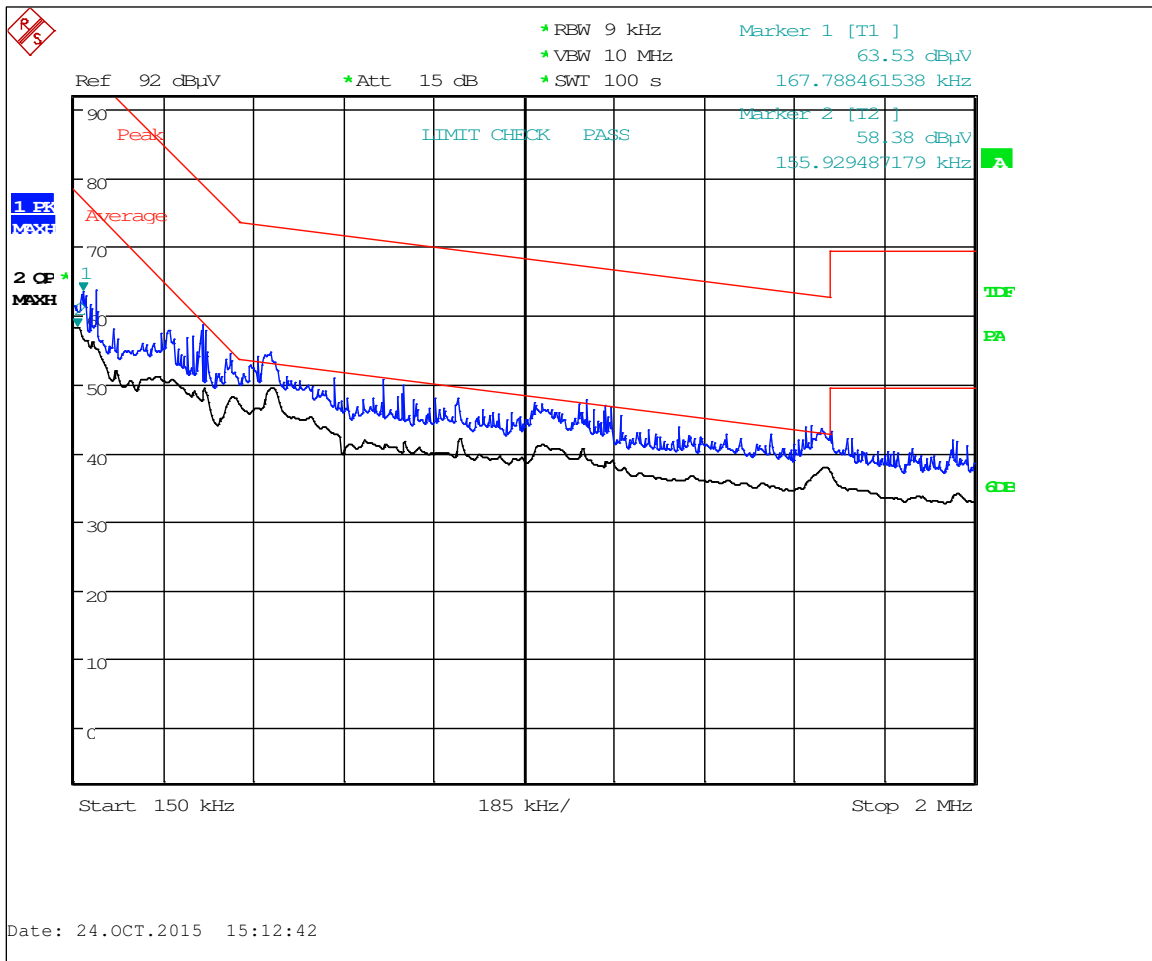

Plot 6-6: Radiated Emissions Transmit – 2 MHz – 30 MHz Horizontal Peak/Average

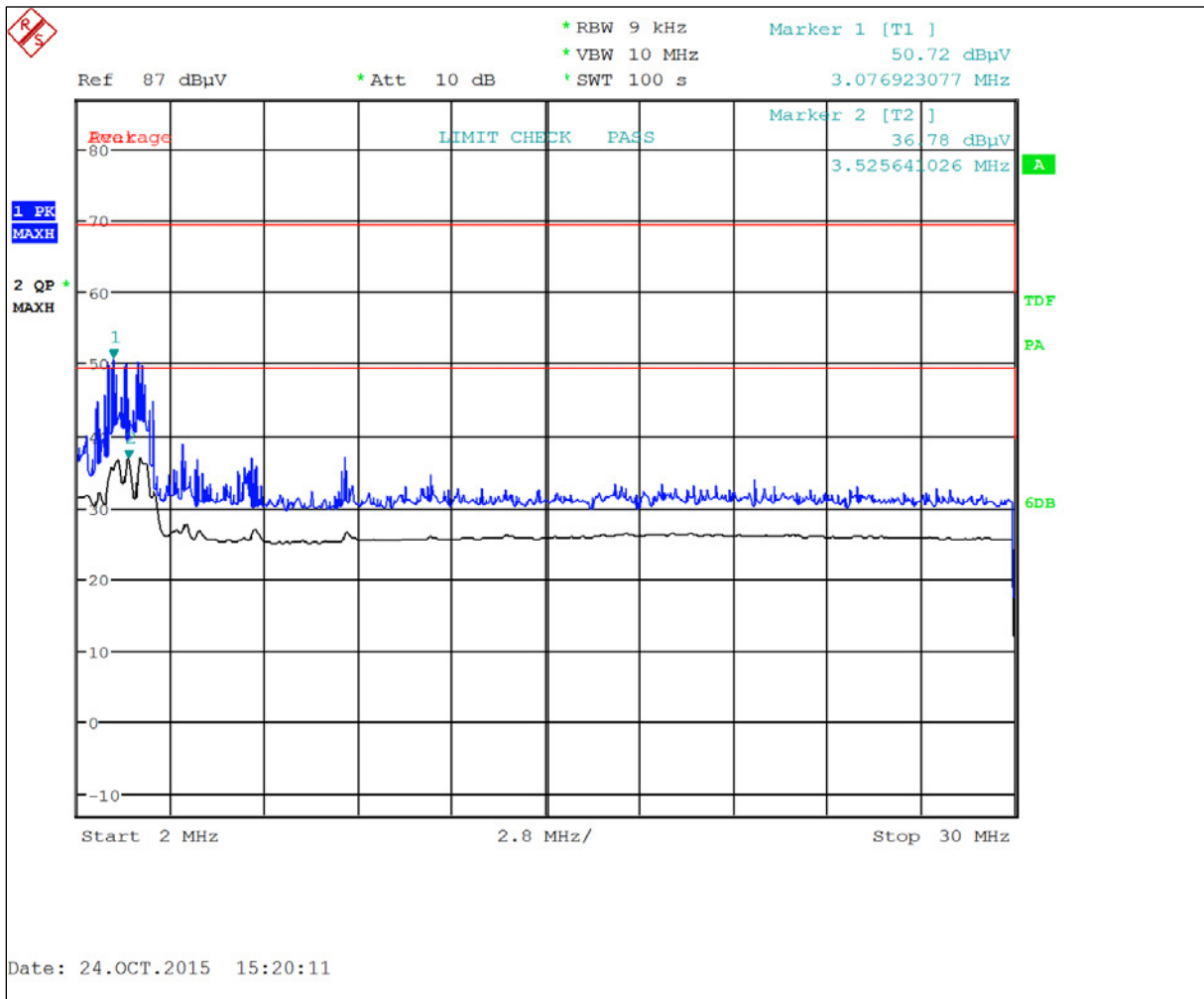

Plot 6-7: Radiated Emissions Transmit – 2 MHz – 30 MHz Vertical Peak/Average

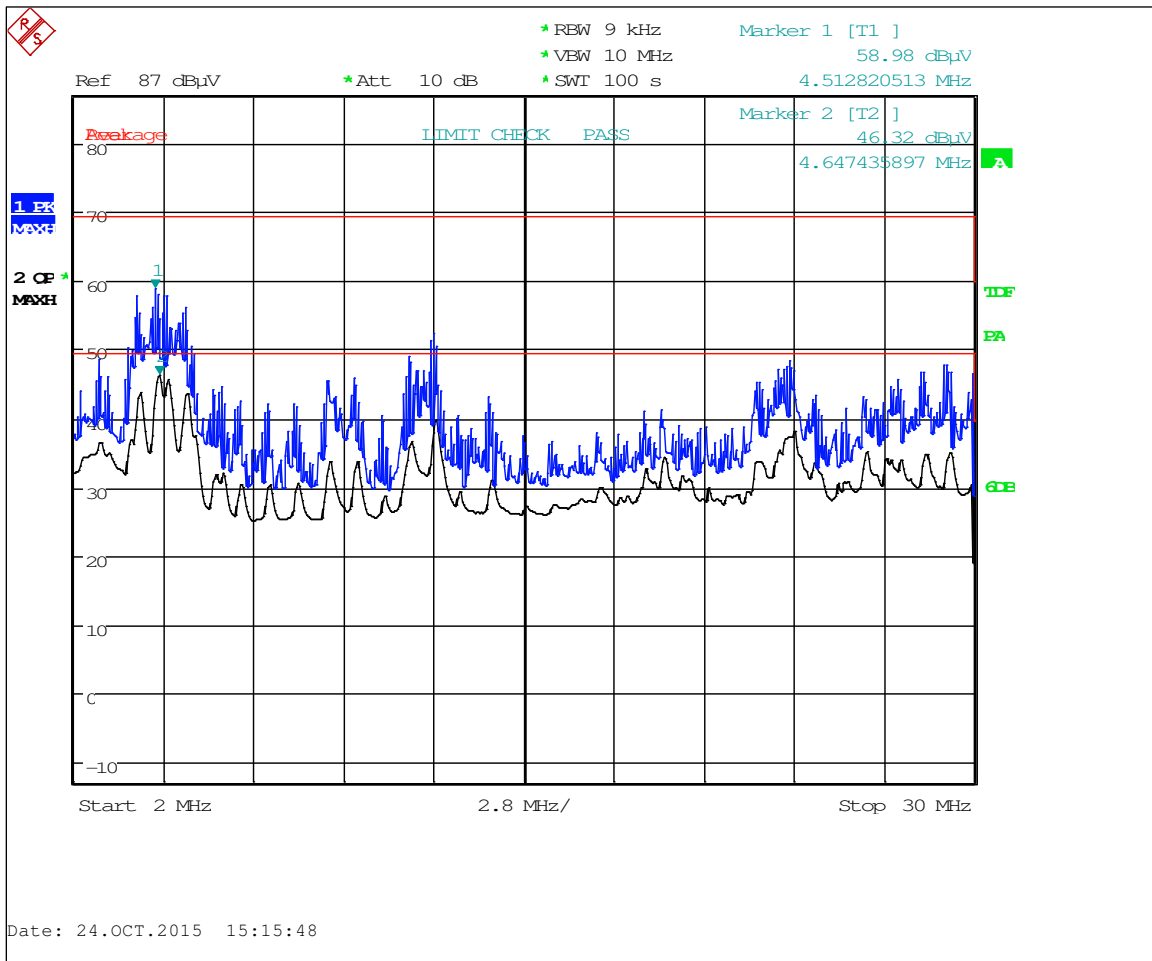

Plot 6-8: Radiated Emissions Transmit – 30 MHz – 1 GHz Horizontal Peak/Average

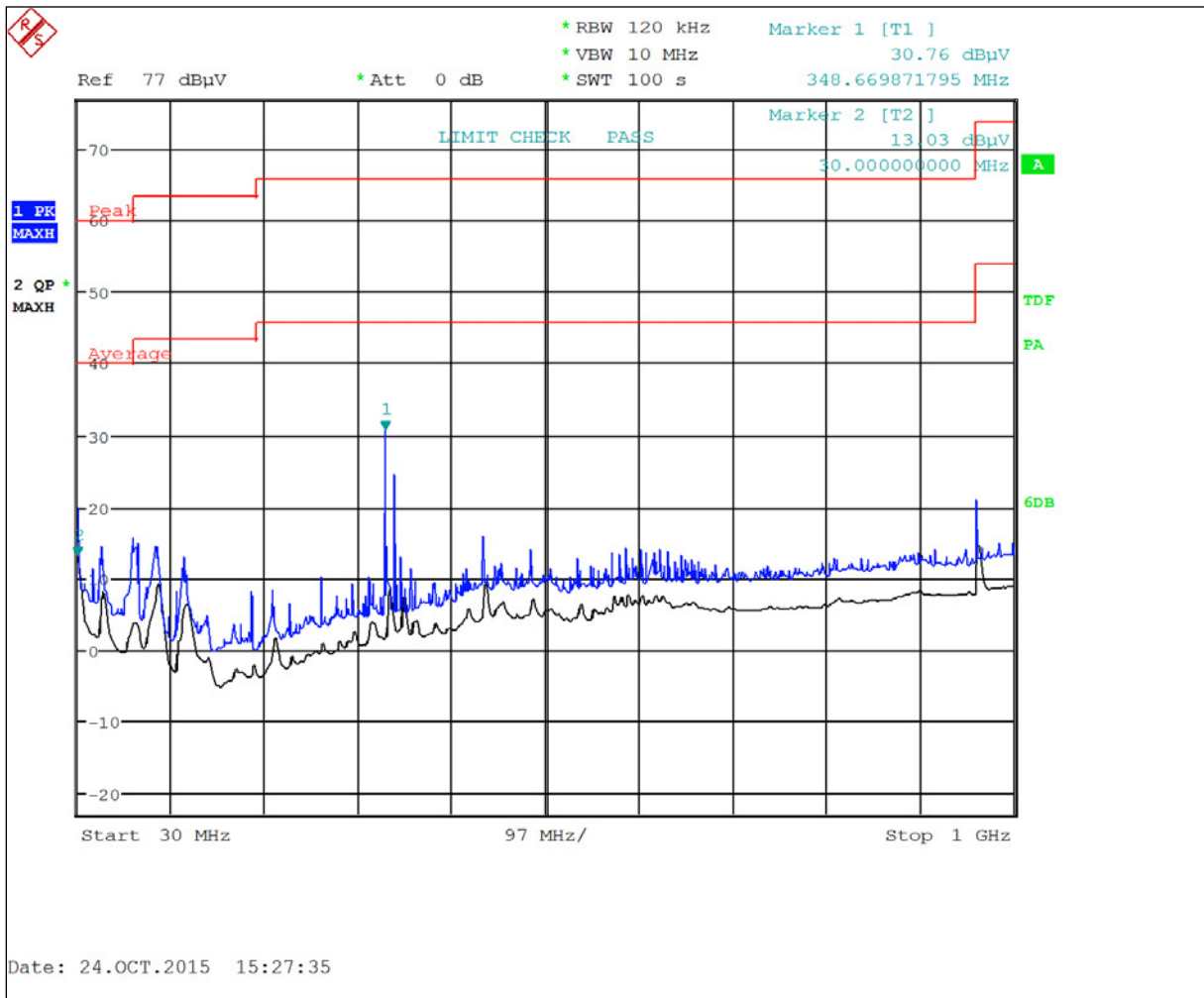

Plot 6-9: Radiated Emissions Transmit – 30 MHz – 1 GHz Vertical Peak/Average

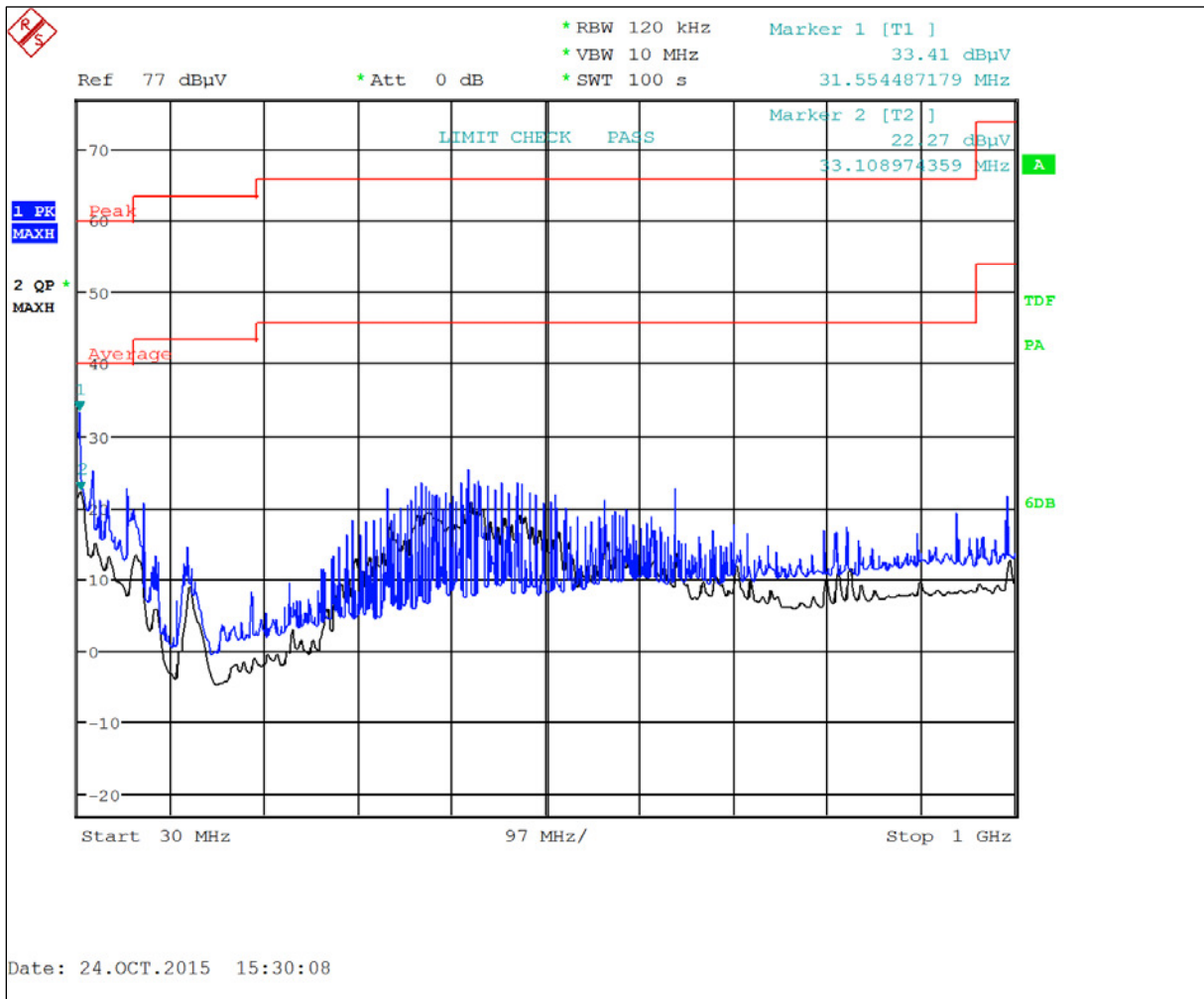

Note: Unwanted emissions were investigated as a digital device (other than harmonics) as required by 15.33(a)(3).

6.3.1.3 Radiated Emissions 1 GHz – 26 GHz Test Data – TC#1 Steel Container

Plot 6-10: Radiated Emissions 1 GHz – 2 GHz Horizontal Peak/Average

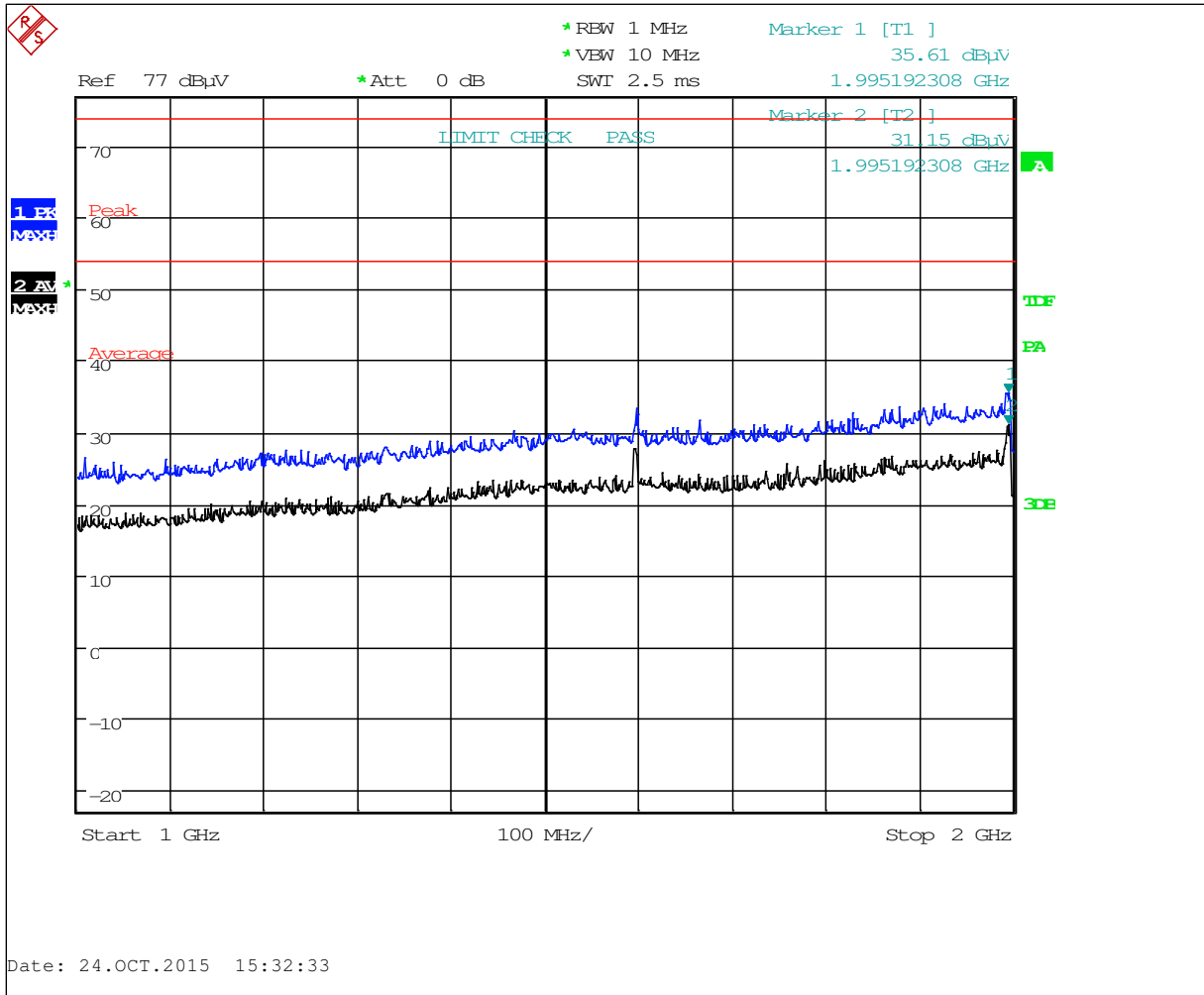

Plot 6-11: Radiated Emissions 1 GHz – 2 GHz Vertical Peak/Average

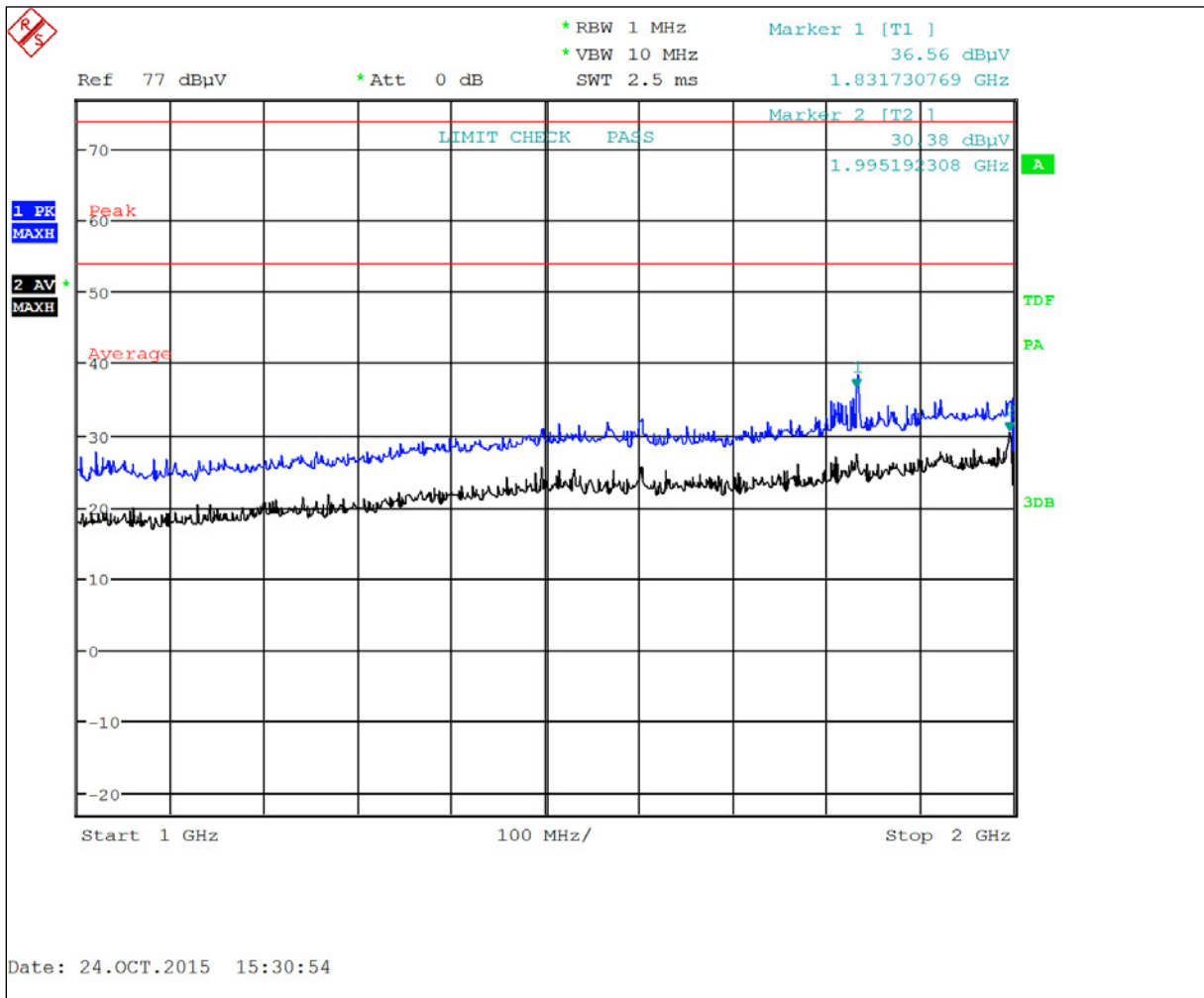

Plot 6-12: Radiated Emissions 2 GHz – 4 GHz Horizontal Peak/Average

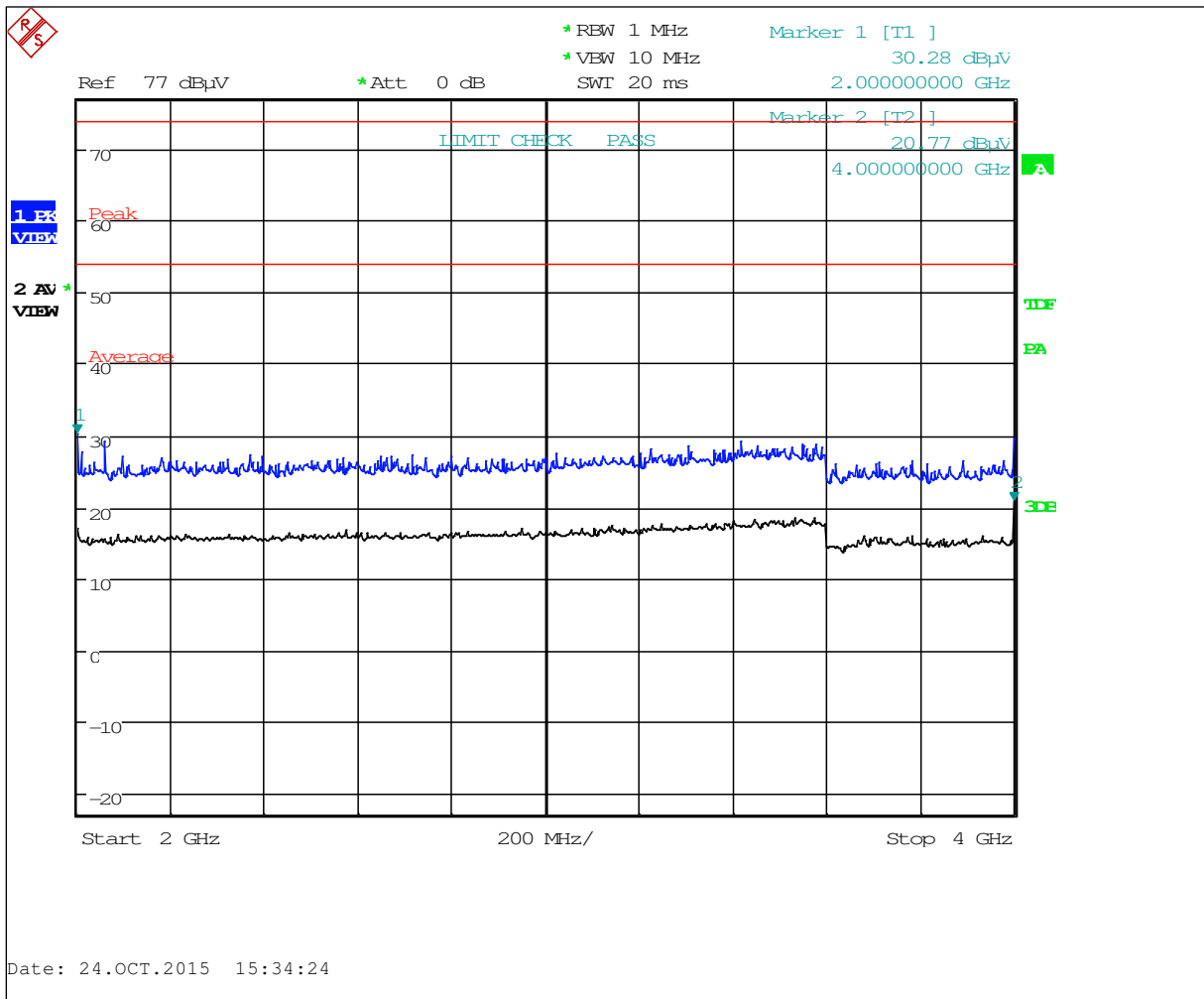

Plot 6-13: Radiated Emissions 2 GHz – 4 GHz Vertical Peak/Average

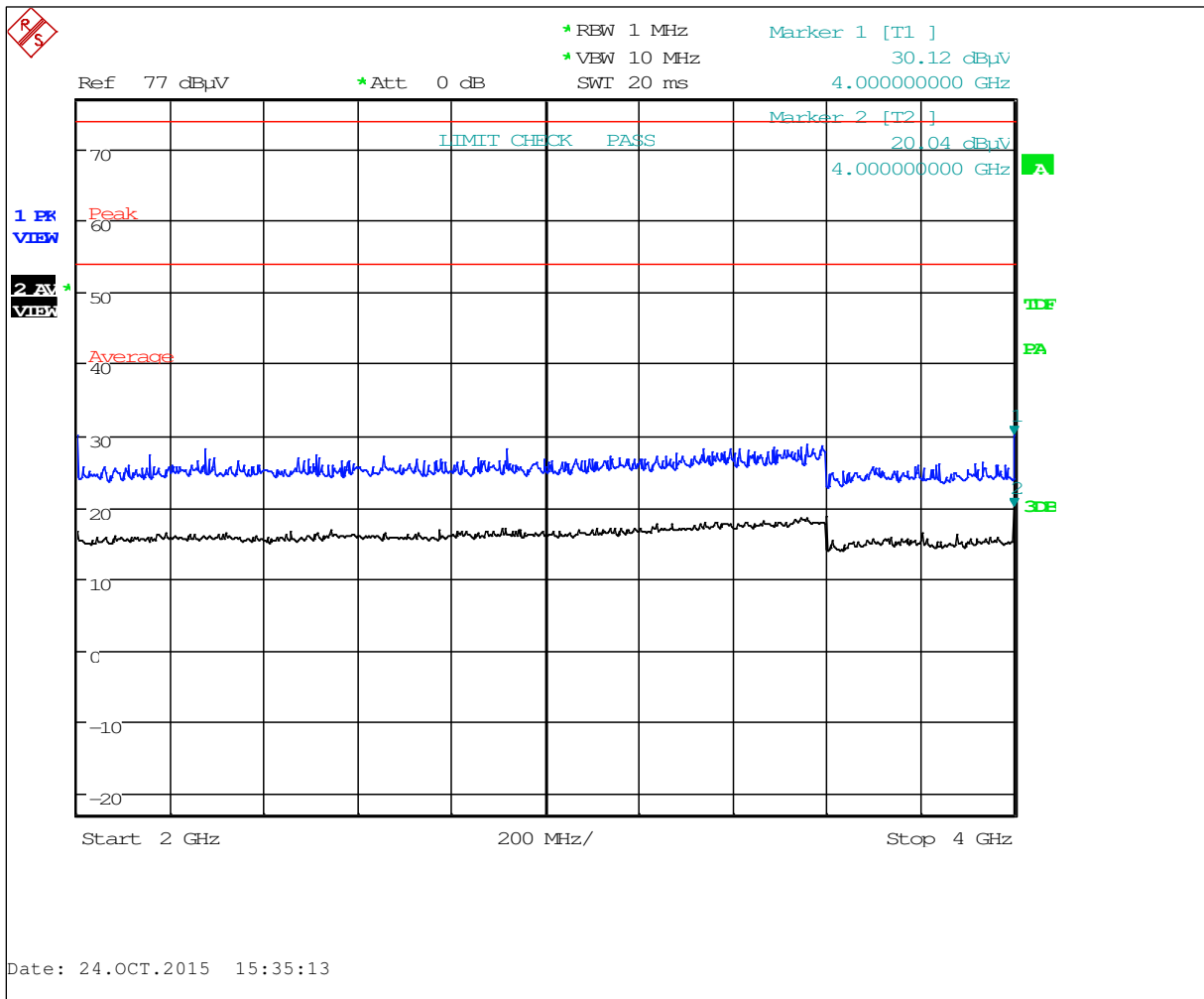

Plot 6-14: Radiated Emissions 4 GHz – 8 GHz Horizontal Peak/Average

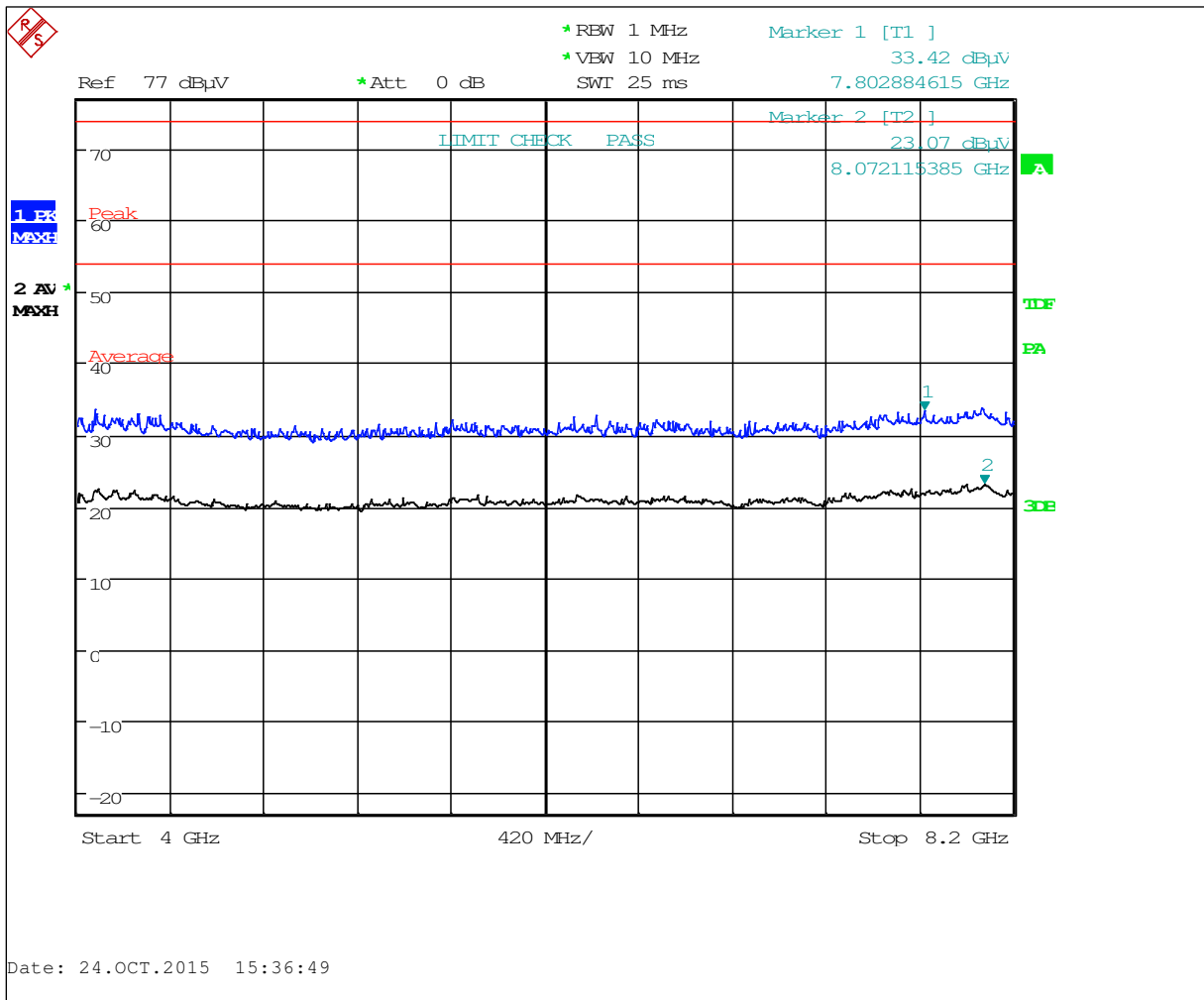

Plot 6-15: Radiated Emissions 4 GHz – 8 GHz Vertical Peak/Average

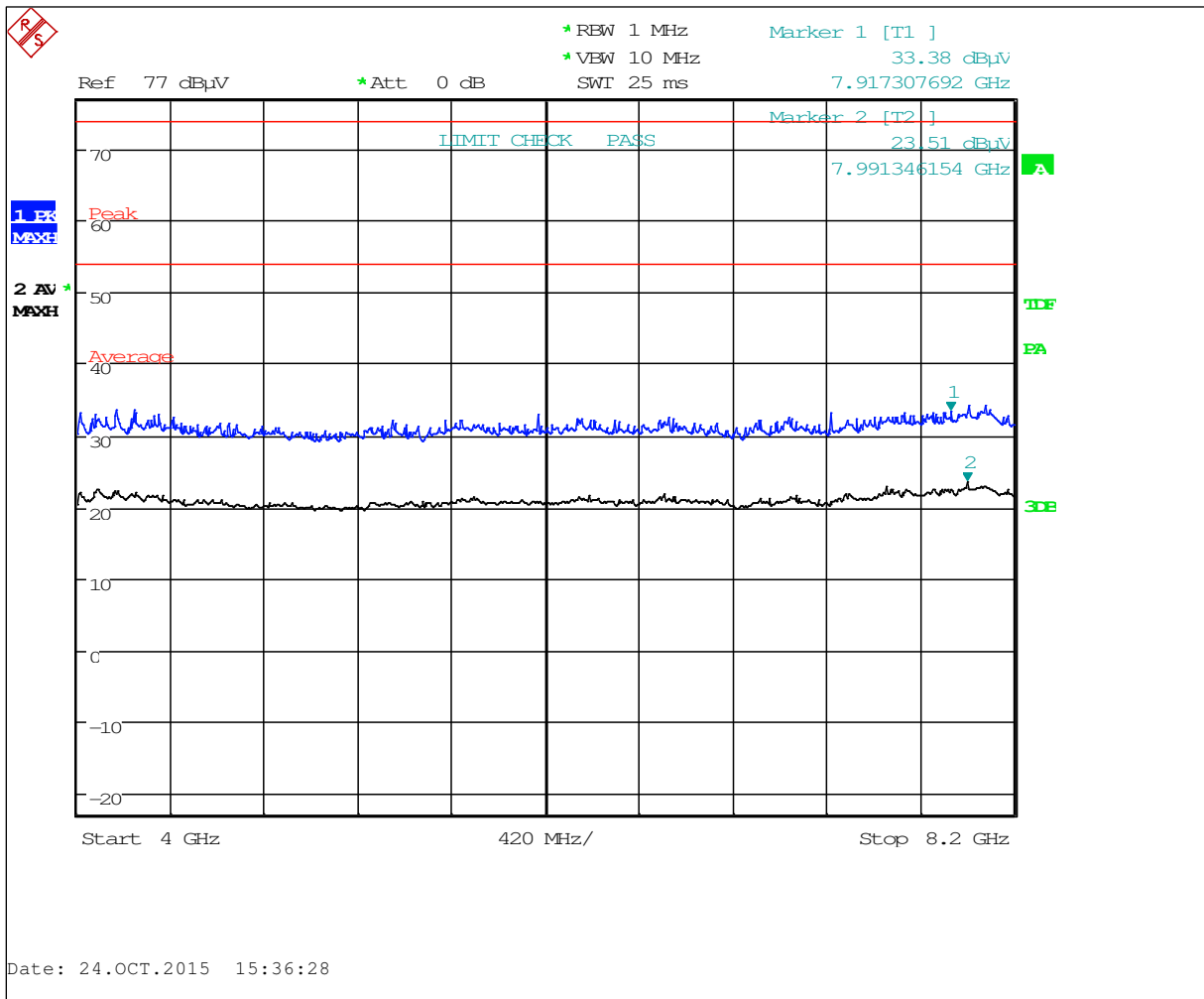

Plot 6-16: Radiated Emissions 8 GHz – 12 GHz Horizontal Peak/Average

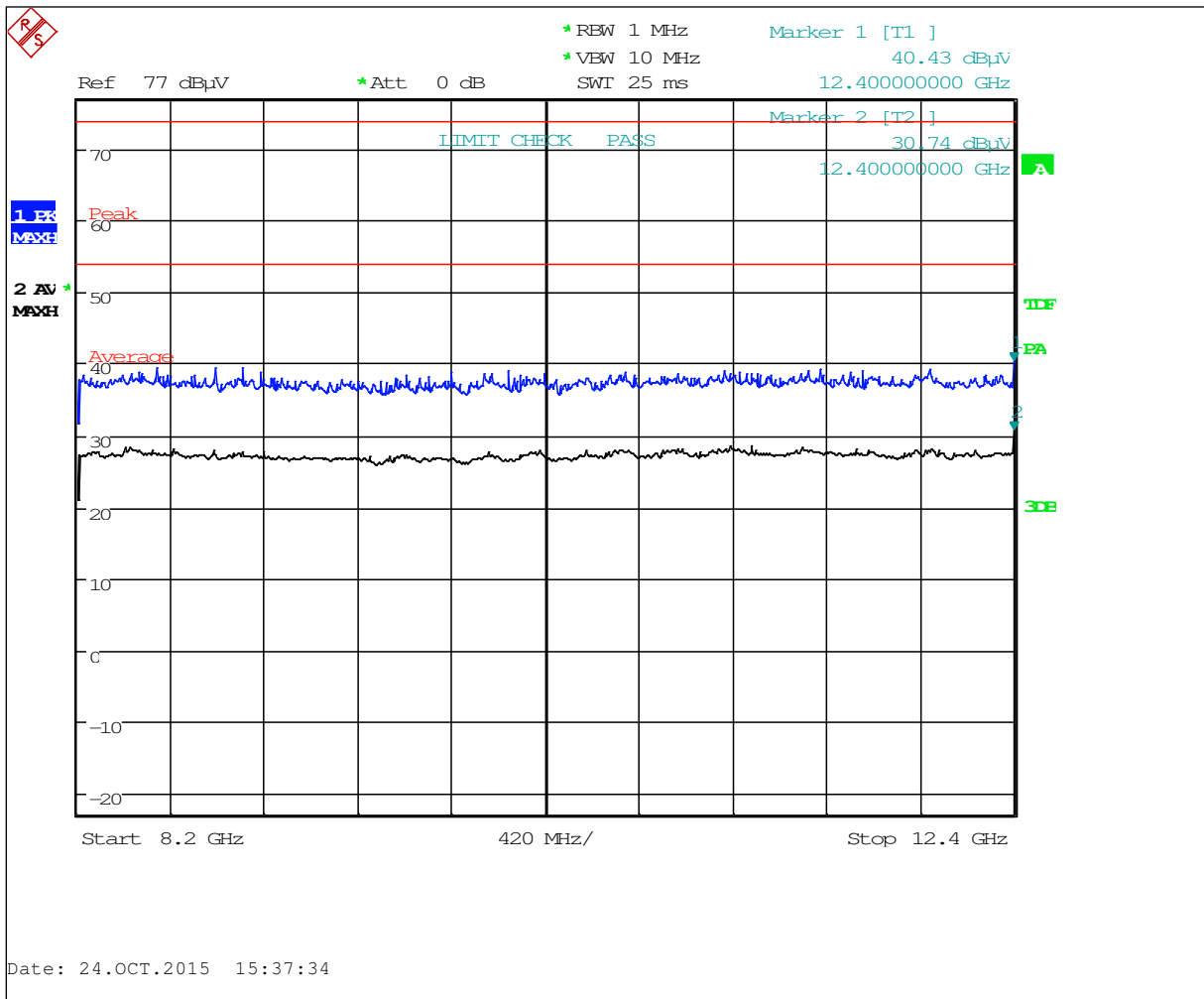

Plot 6-17: Radiated Emissions 8 GHz – 12 GHz Vertical Peak/Average

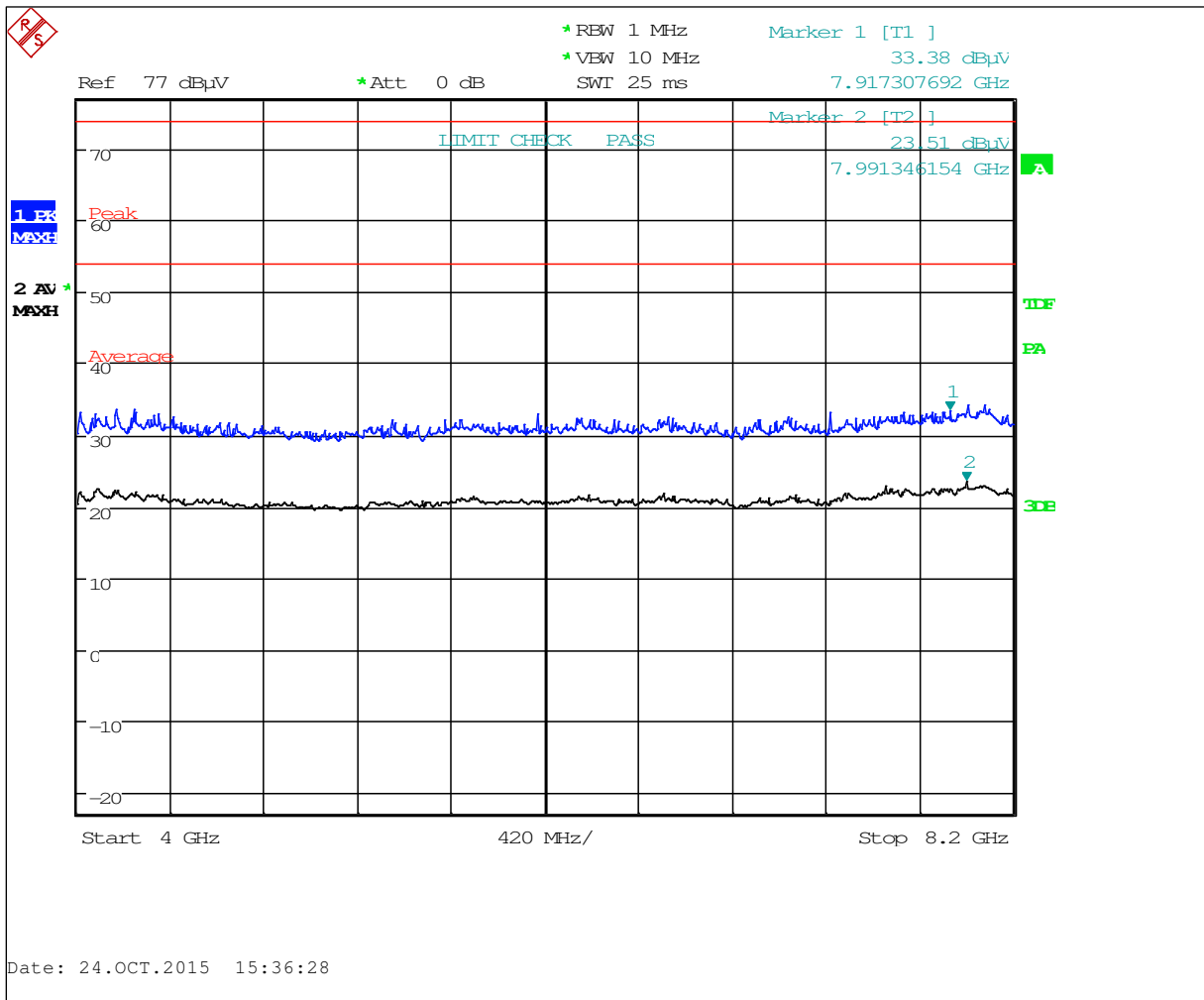

Plot 6-18: Radiated Emissions 18 GHz – 26 GHz Horizontal Peak/Average

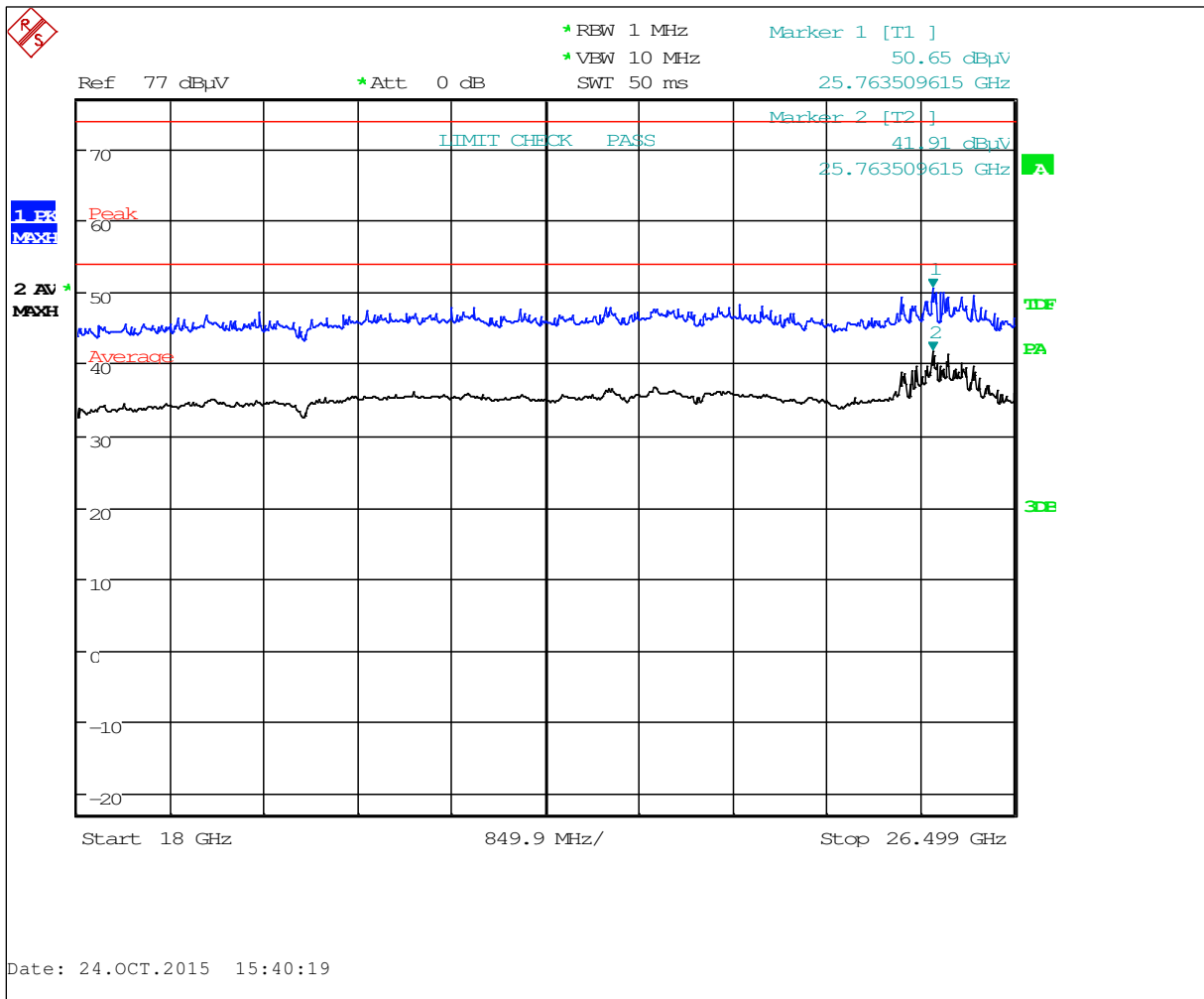

Plot 6-19: Radiated Emissions 18 GHz – 26 GHz Vertical Peak/Average

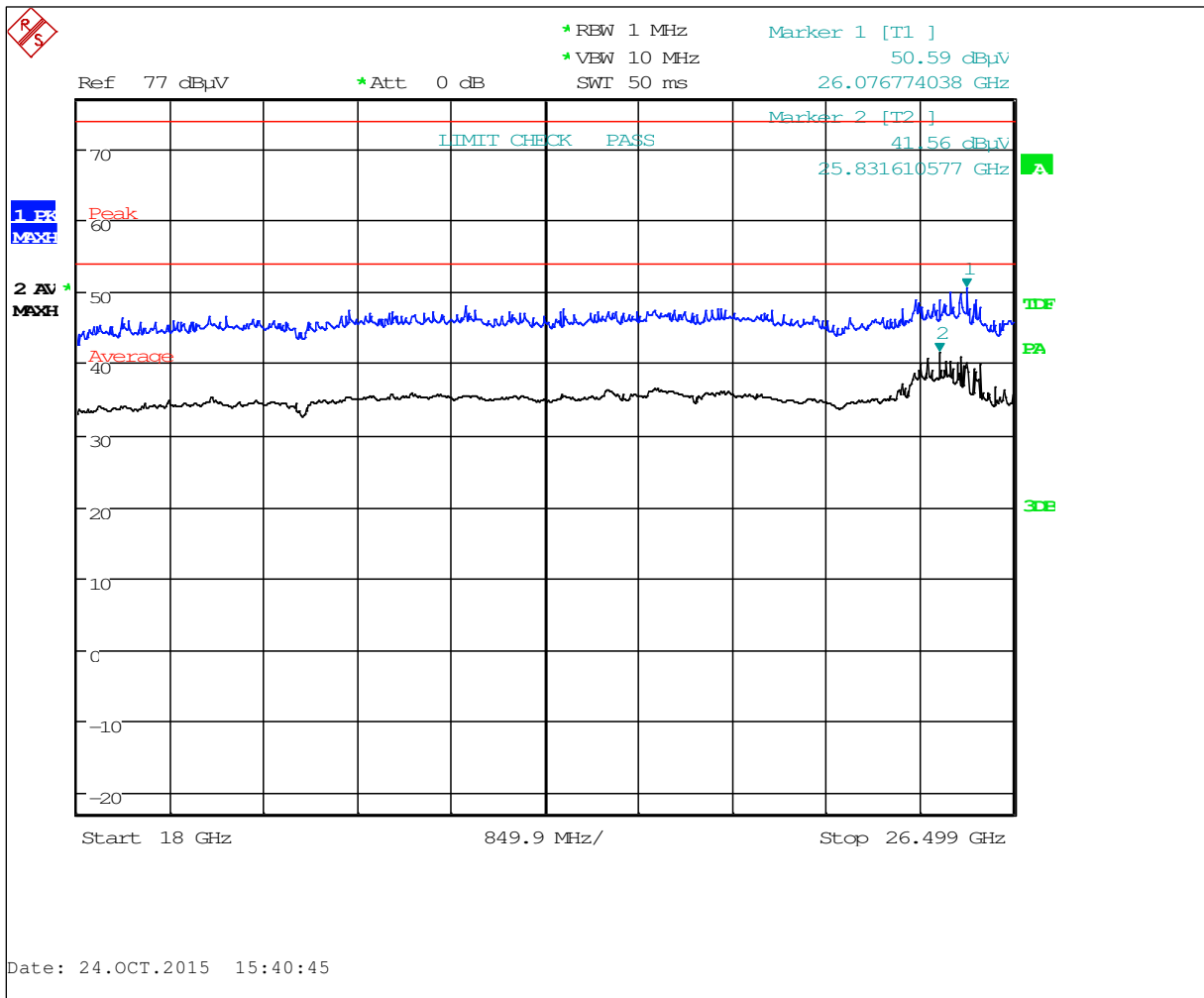

6.3.1.4 Radiated Emissions Carrier Test Data - TC#2 Steel Container

Plot 6-20: Radiated Emissions of Carrier - TC #2 Steel Container

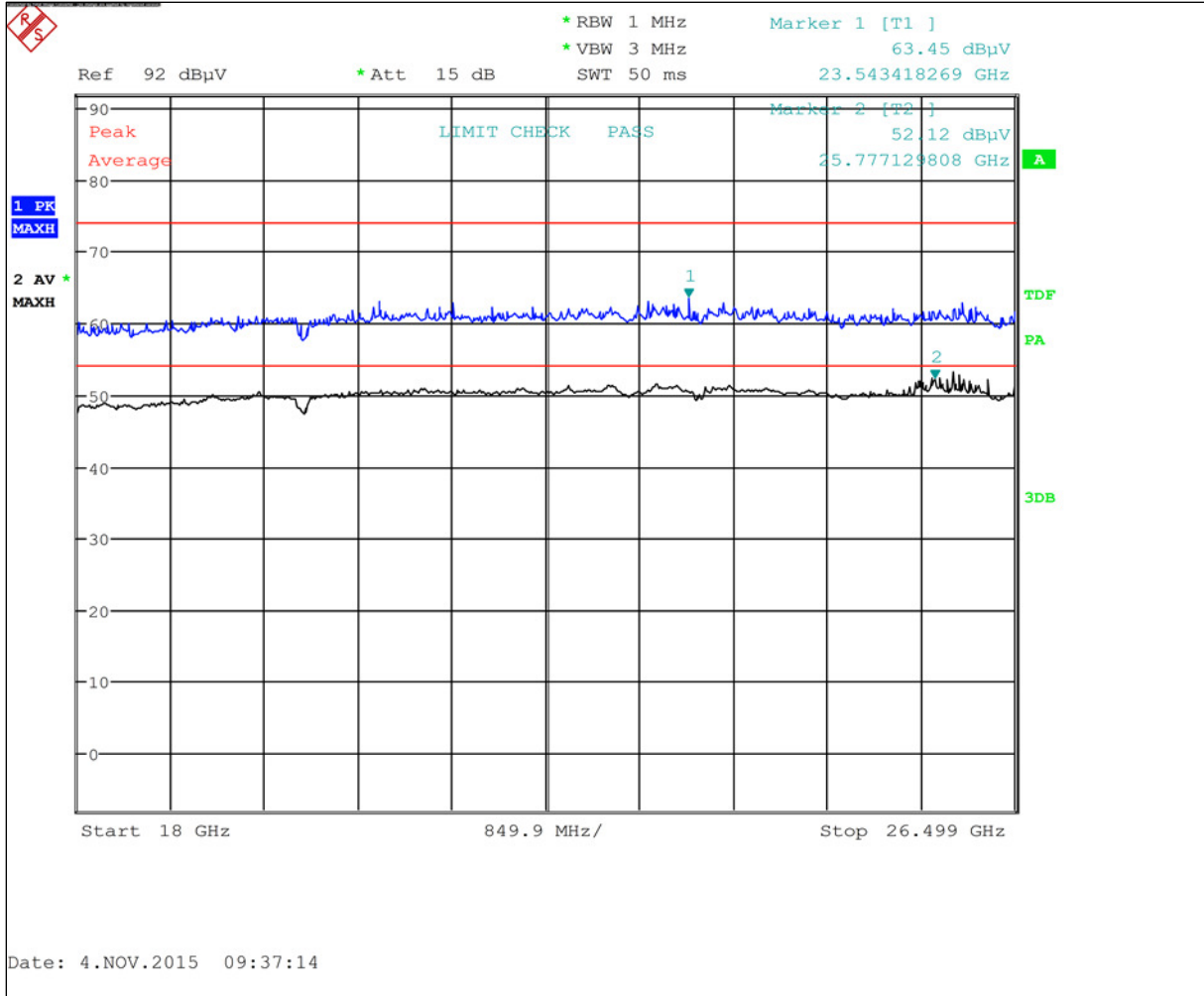
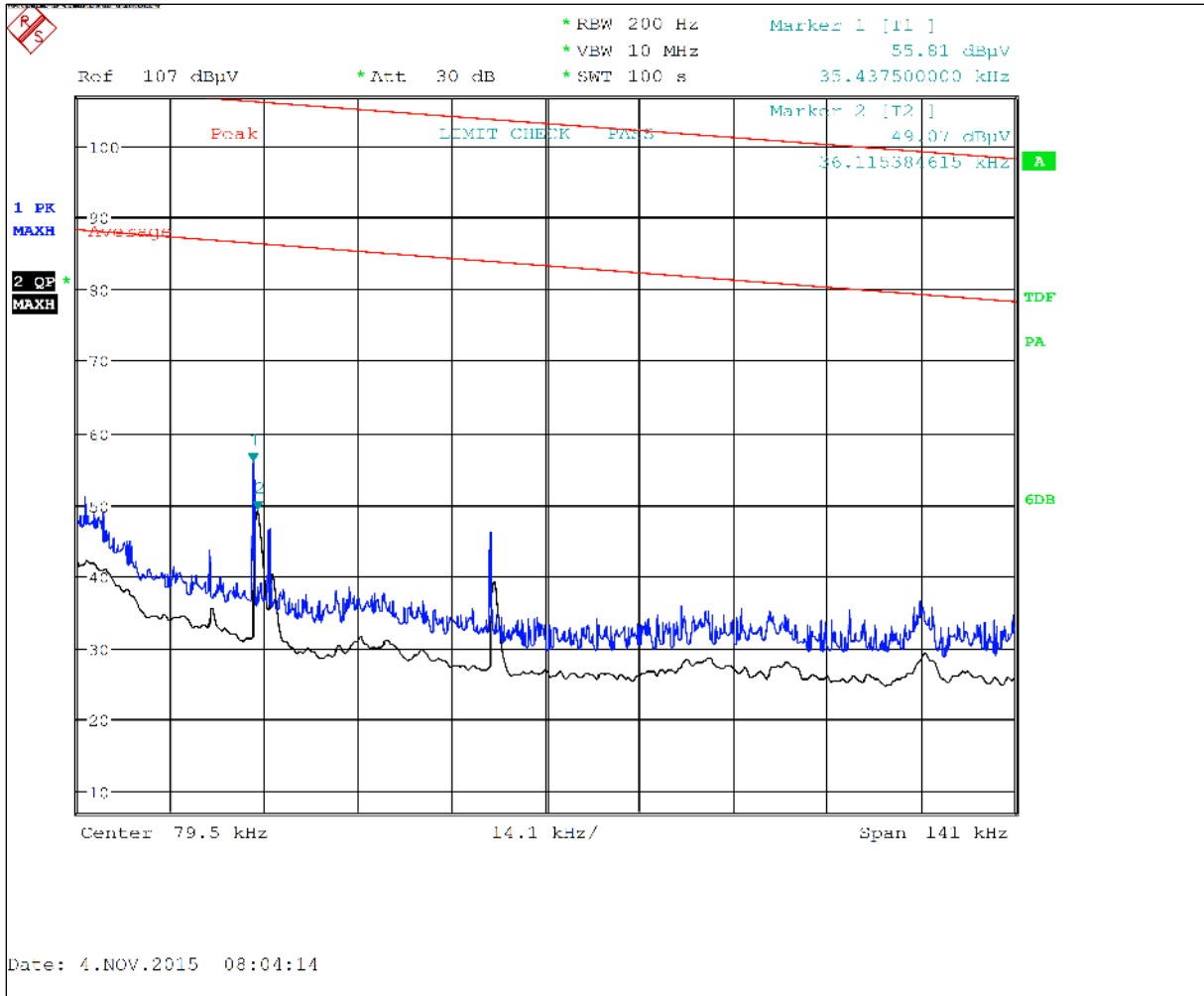

Table 6-2: Radiated Emissions of Carrier – TC #2 Steel Container

Frequency (GHz)	Detector	Test Antenna Pol	Corrected Spectrum Analyzer Level (dBuV/m)	FCC Limit (dBuV)	Margin (dB)	Corrected Spectrum Analyzer Level (dBm/MHz)	IC Limit (dBm/MHz)	Margin (dBm)
25.5434	Peak	V	63.5	74.0	-10.5		NA	
25.7771	Average	V	52.1	54.0	-1.9	-43.1	-41.3	1.8

6.3.1.5 Radiated Emissions Below 1 GHz Test Data – TC#2 Steel Container

Plot 6-21: Radiated Emissions Transmit – 9 kHz – 150 kHz Horizontal Peak/Average



Plot 6-22: Radiated Emissions Transmit – 9 kHz – 150 kHz Vertical Peak/Average

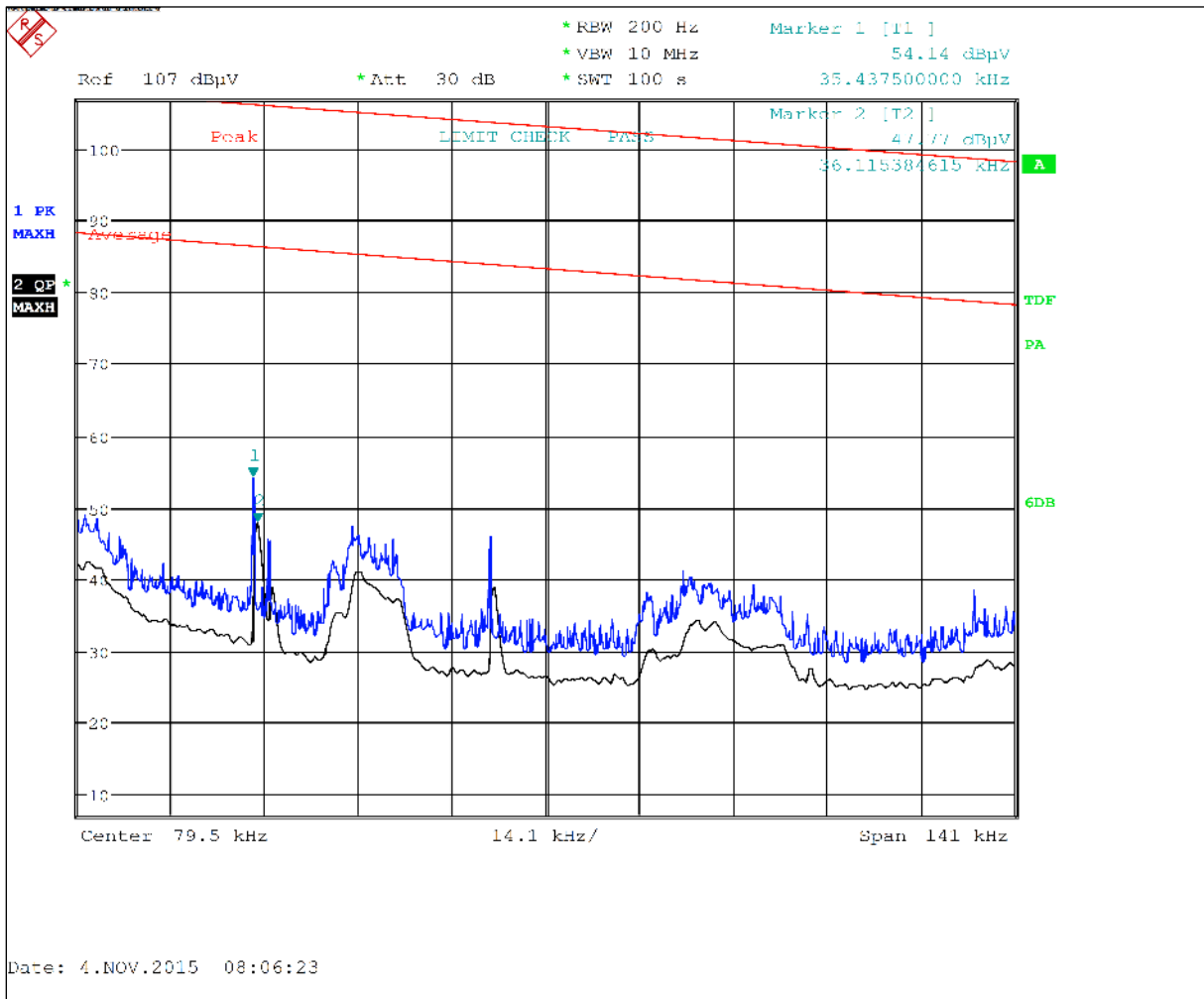

Plot 6-23: Radiated Emissions Transmit – 150 kHz – 2 MHz Horizontal Peak/Average

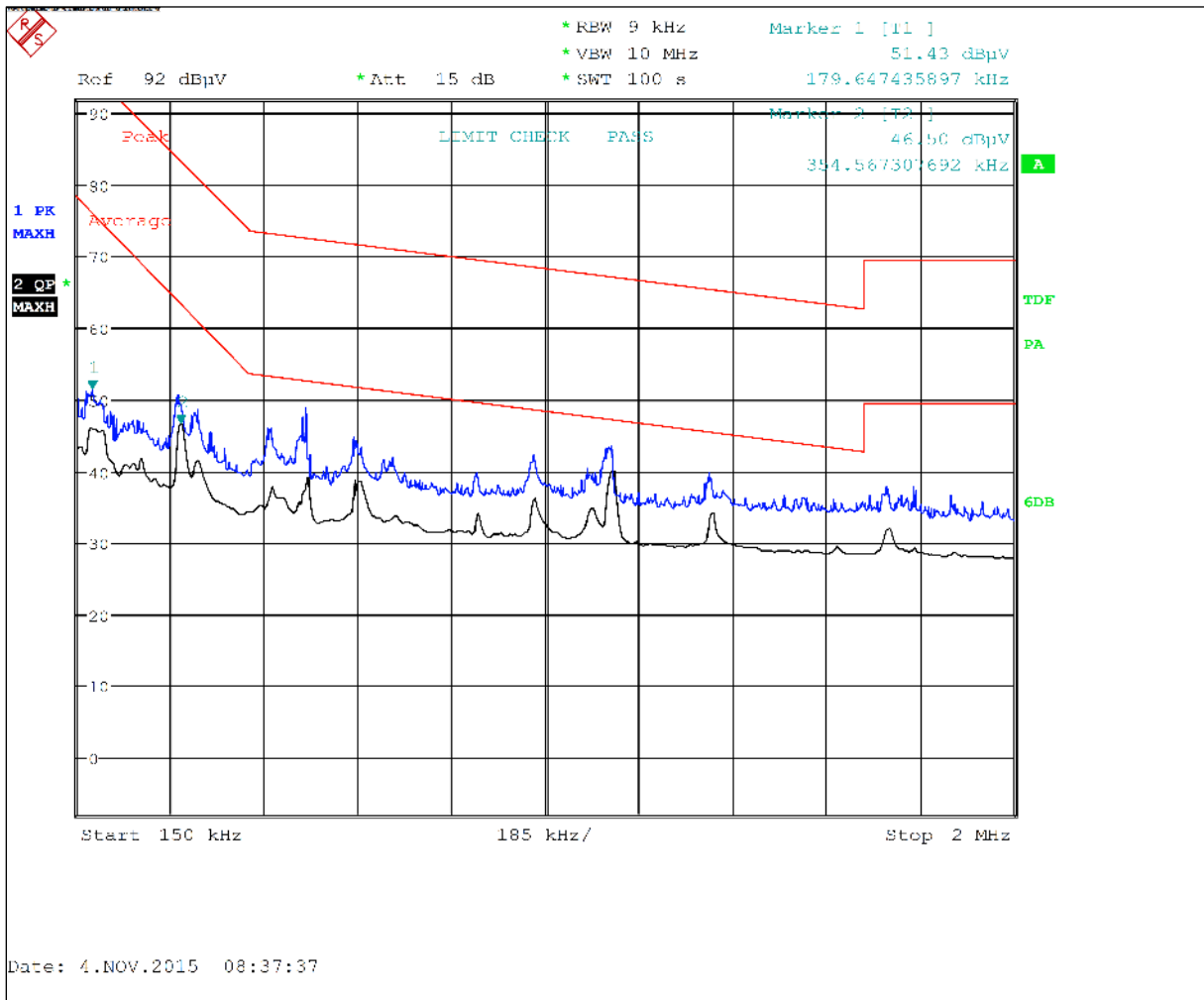

Plot 6-24: Radiated Emissions Transmit – 150 kHz – 2 MHz Vertical Peak/Average

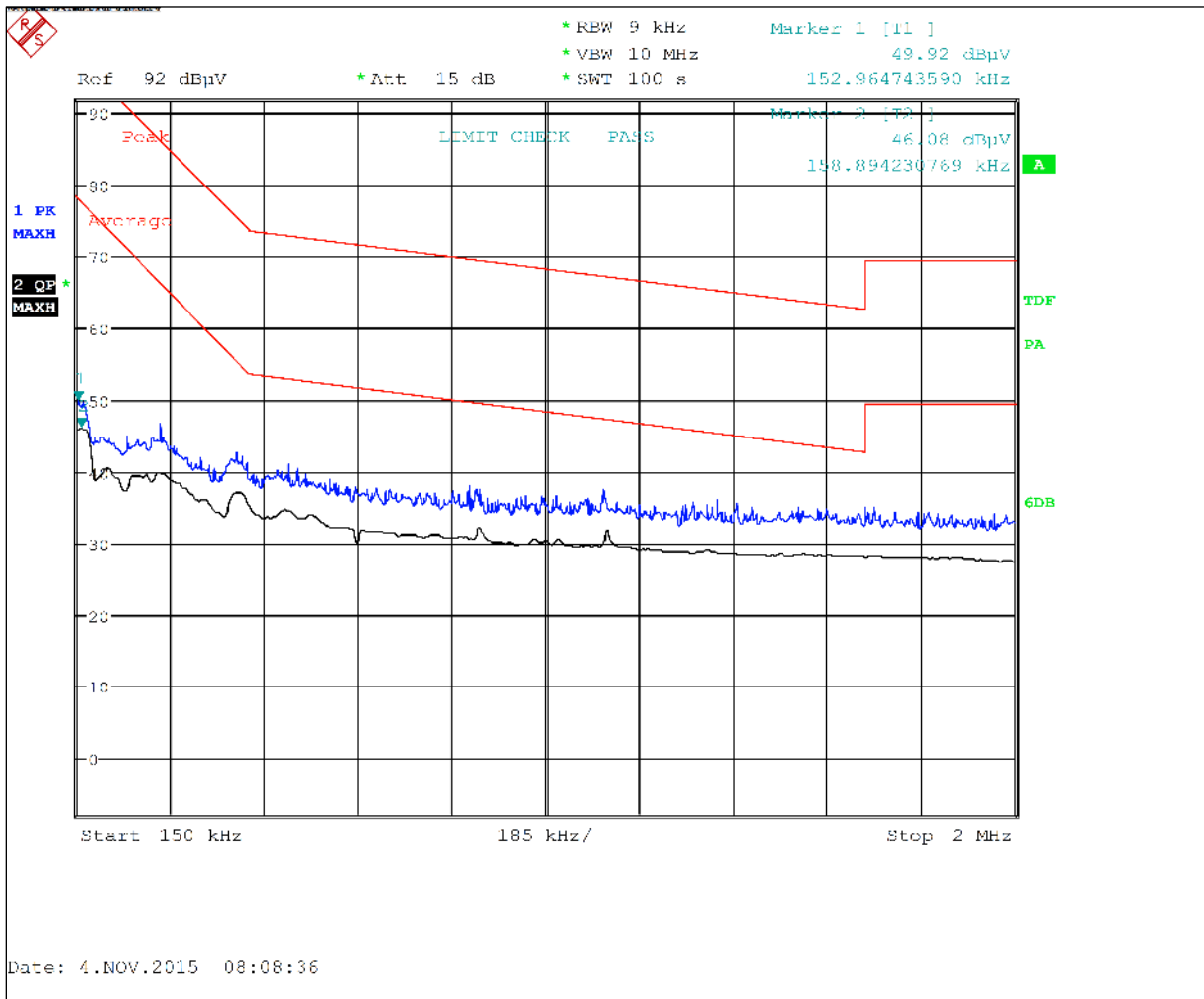

Plot 6-25: Radiated Emissions Transmit – 2 MHz – 30 MHz Horizontal Peak/Average

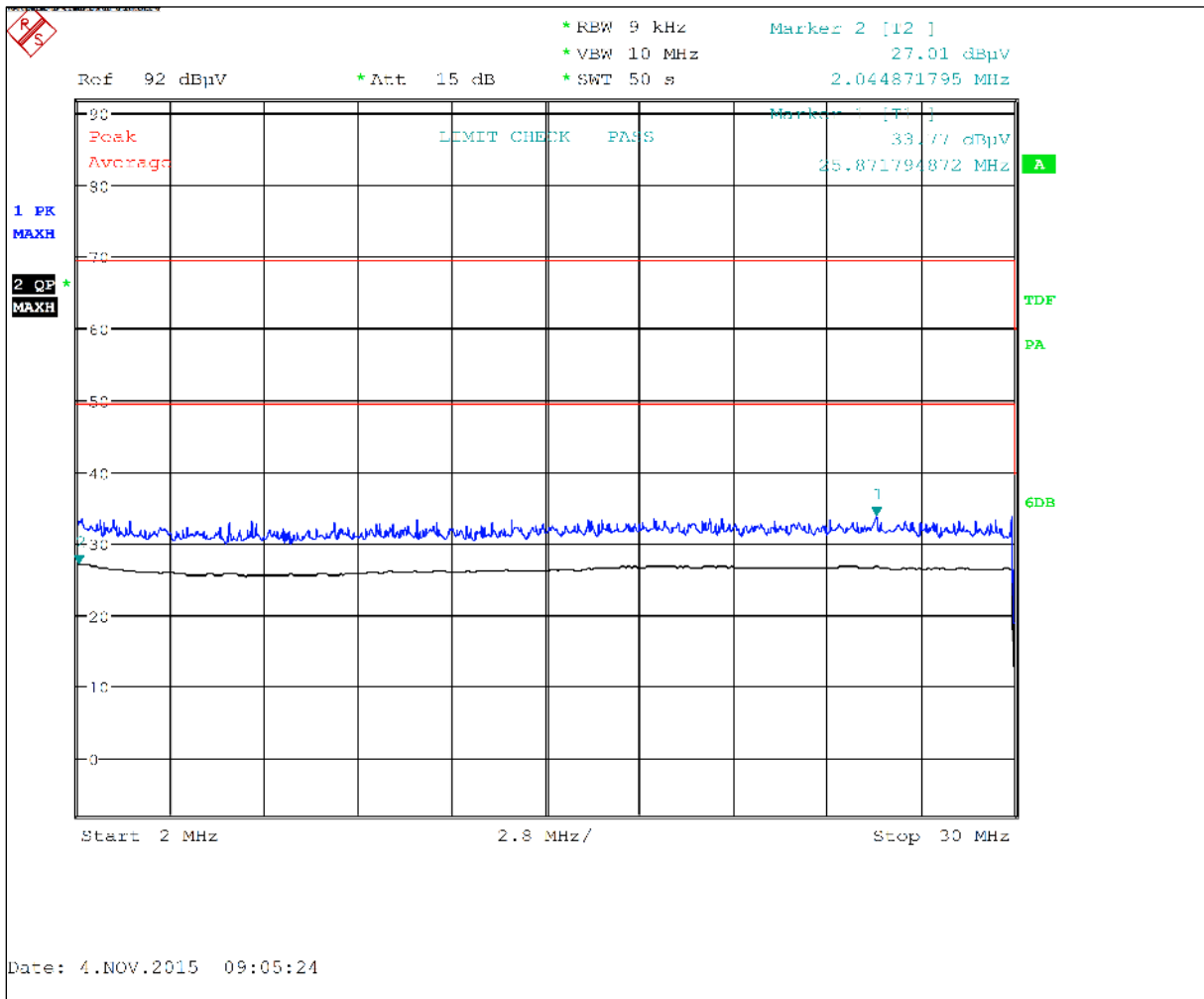

Plot 6-26: Radiated Emissions Transmit – 2 MHz – 30 MHz Vertical Peak/Average

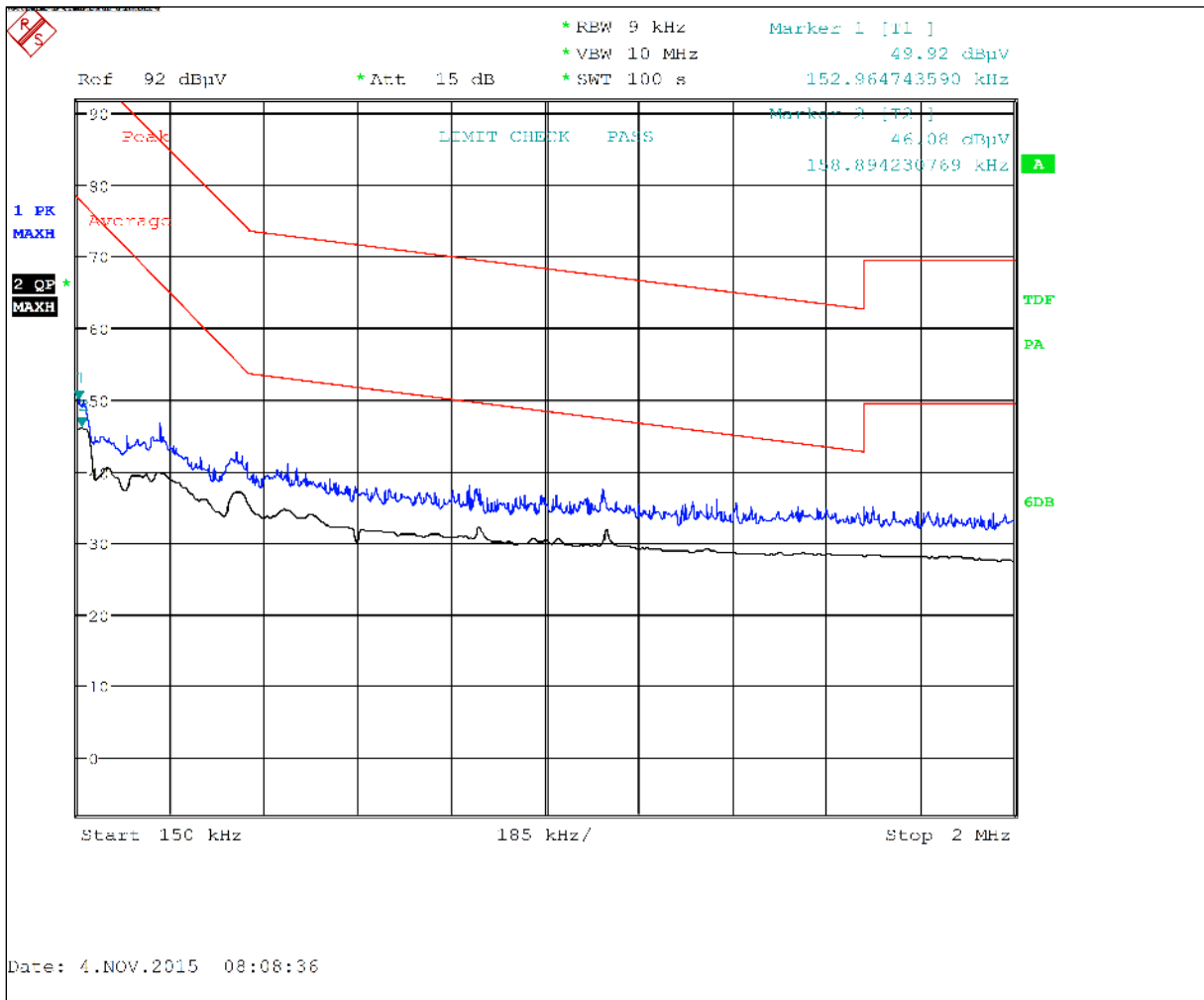

Plot 6-27: Radiated Emissions Transmit – 30 MHz – 1 GHz Horizontal Peak/Average

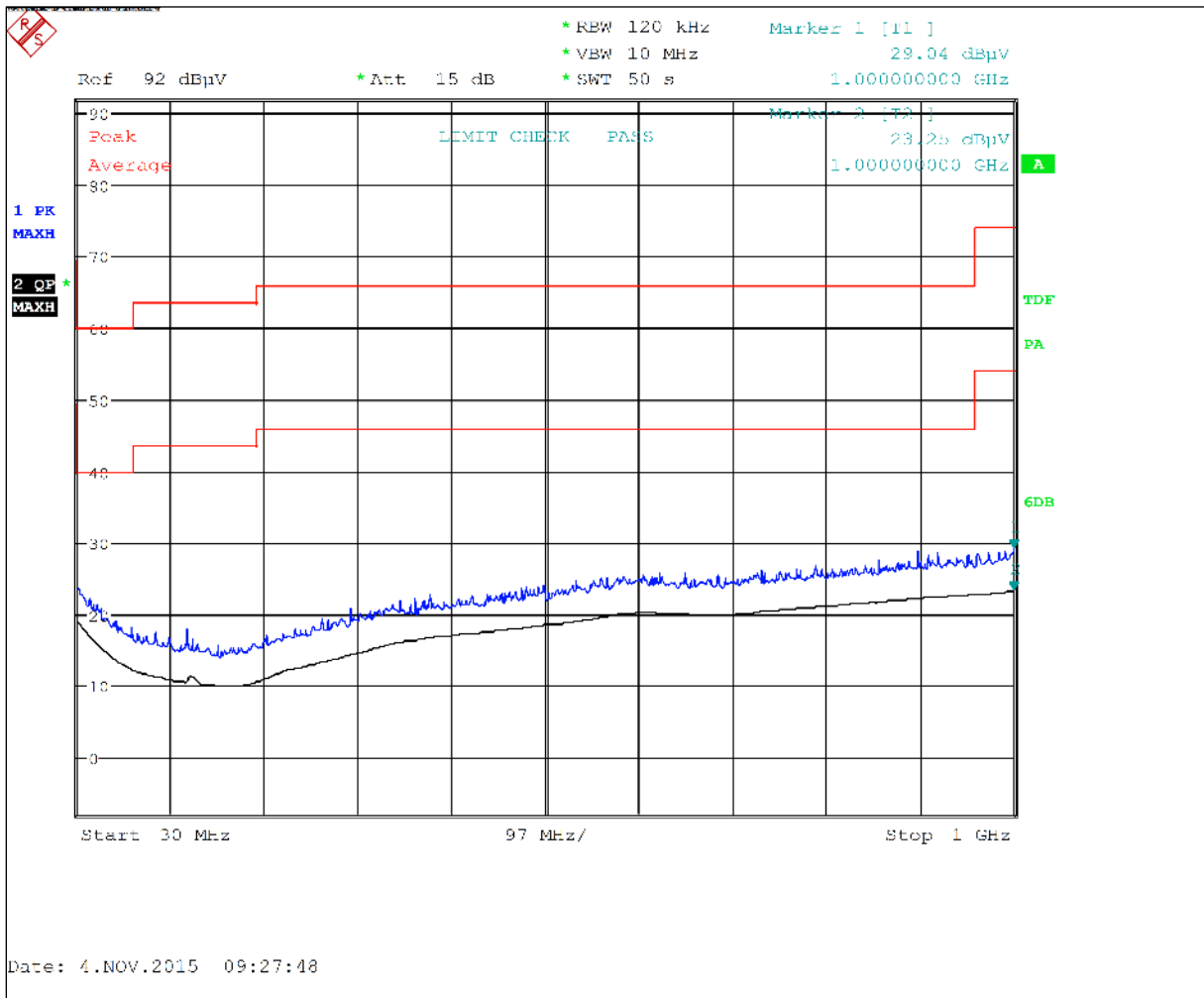

Plot 6-28: Radiated Emissions Transmit – 30 MHz – 1 GHz Vertical Peak/Average

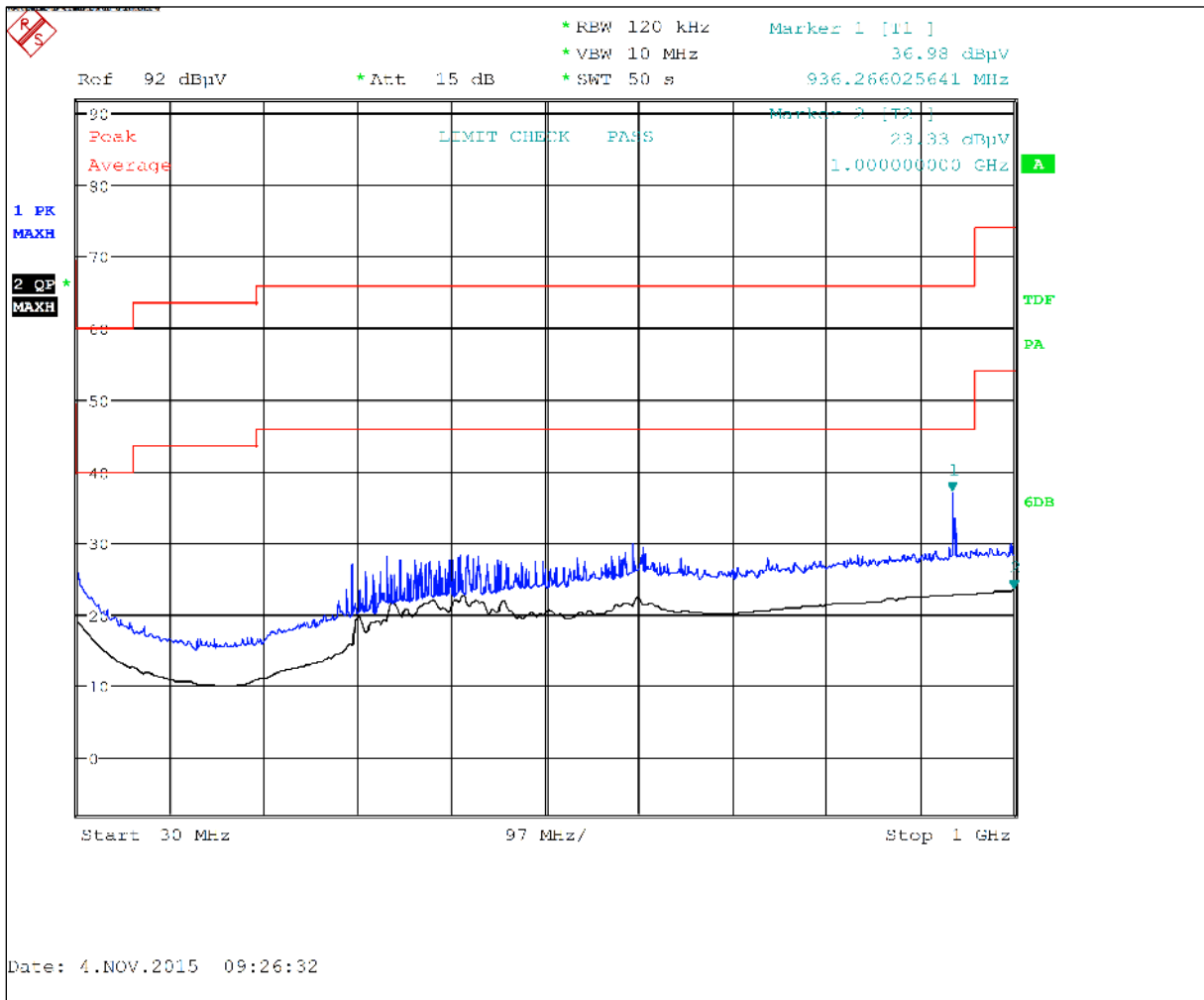

Note: Unwanted emissions were investigated as a digital device (other than harmonics) as required by 15.33(a)(3).

6.3.1.6 Radiated Emissions 1 GHz – 26 GHz Test Data – TC#2 Steel Container

Plot 6-29: Radiated Emissions 1 GHz – 2 GHz Horizontal Peak/Average

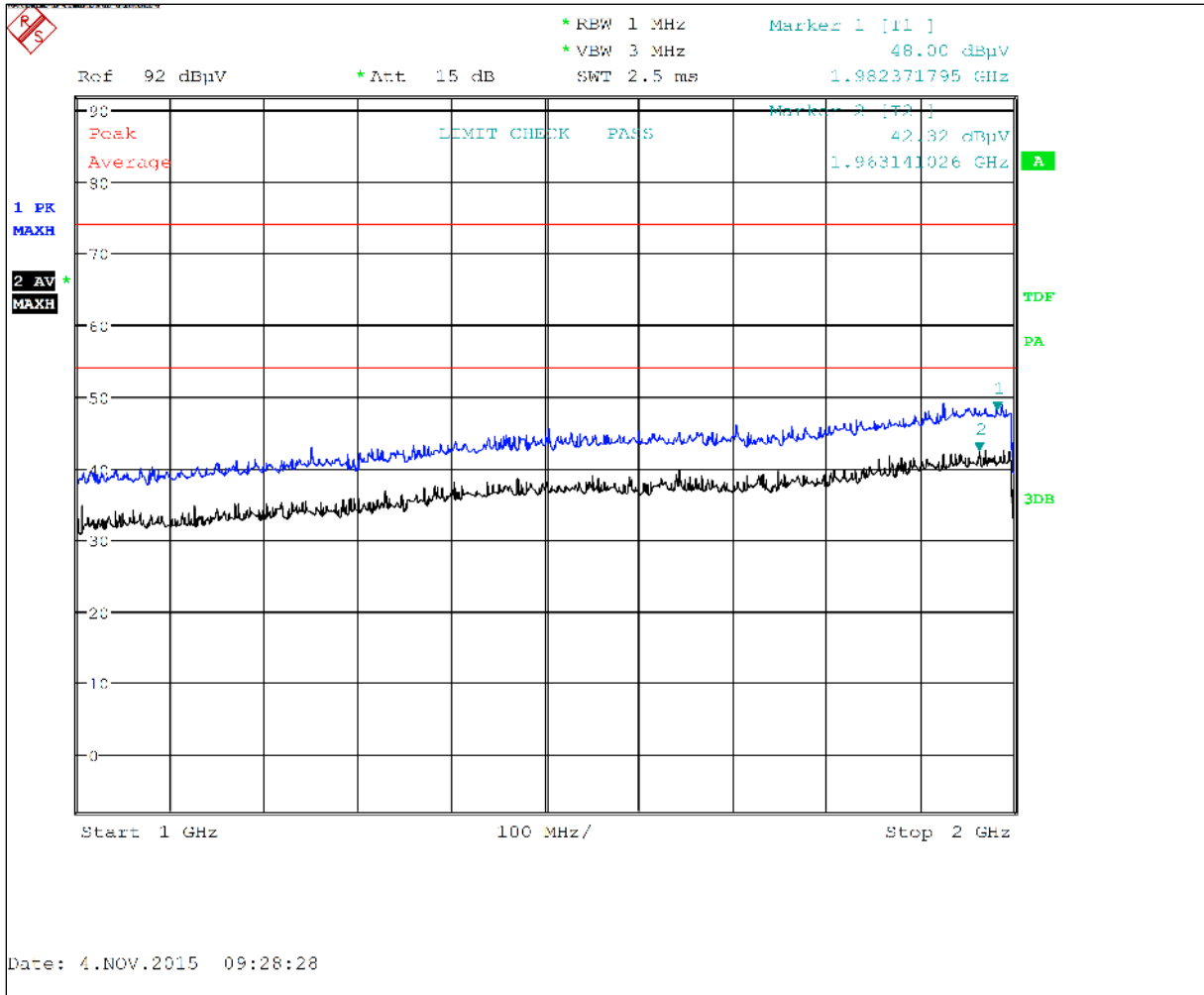

Plot 6-30: Radiated Emissions 1 GHz – 2 GHz Vertical Peak/Average

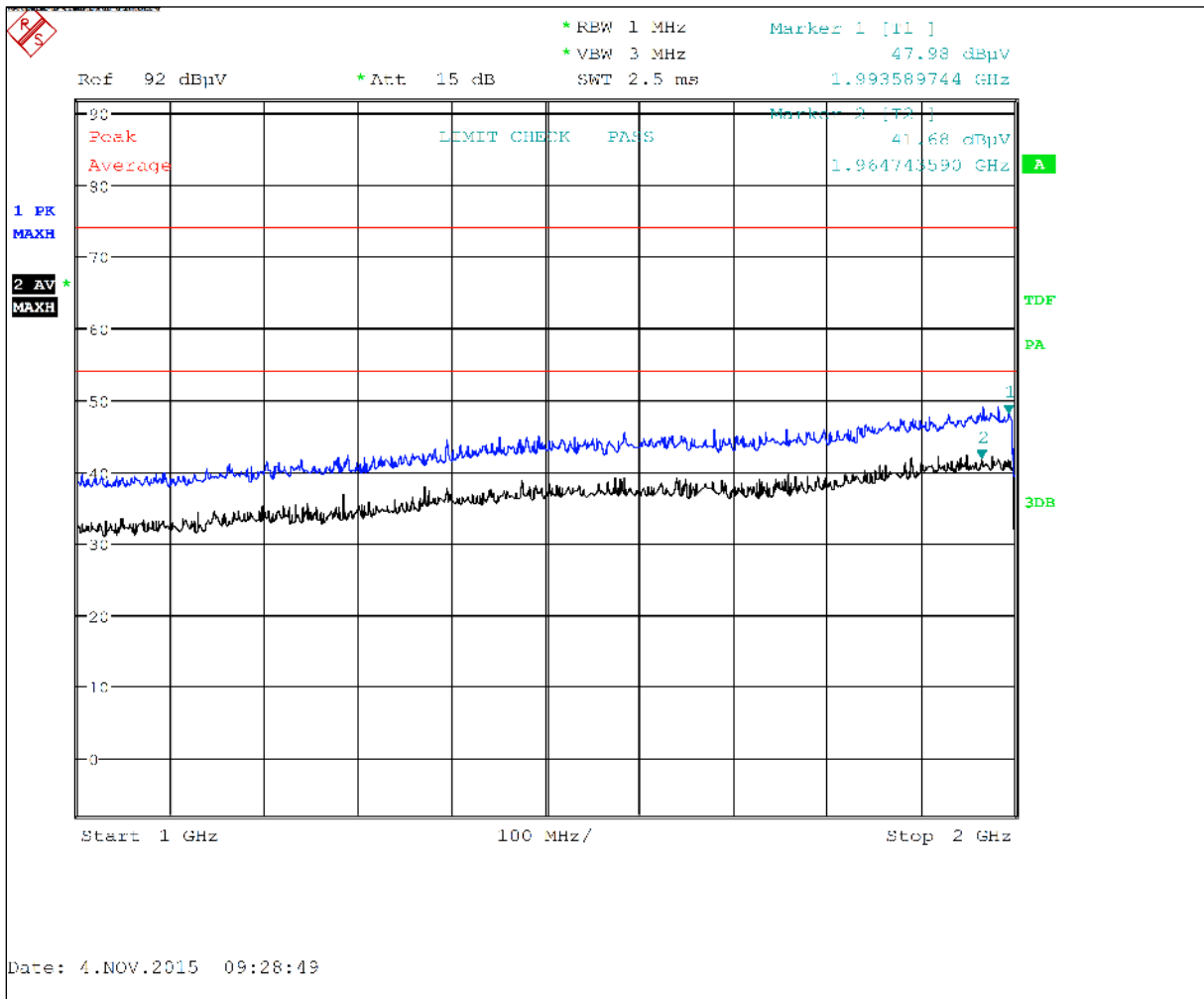

Plot 6-31: Radiated Emissions 2 GHz – 4 GHz Horizontal Peak/Average

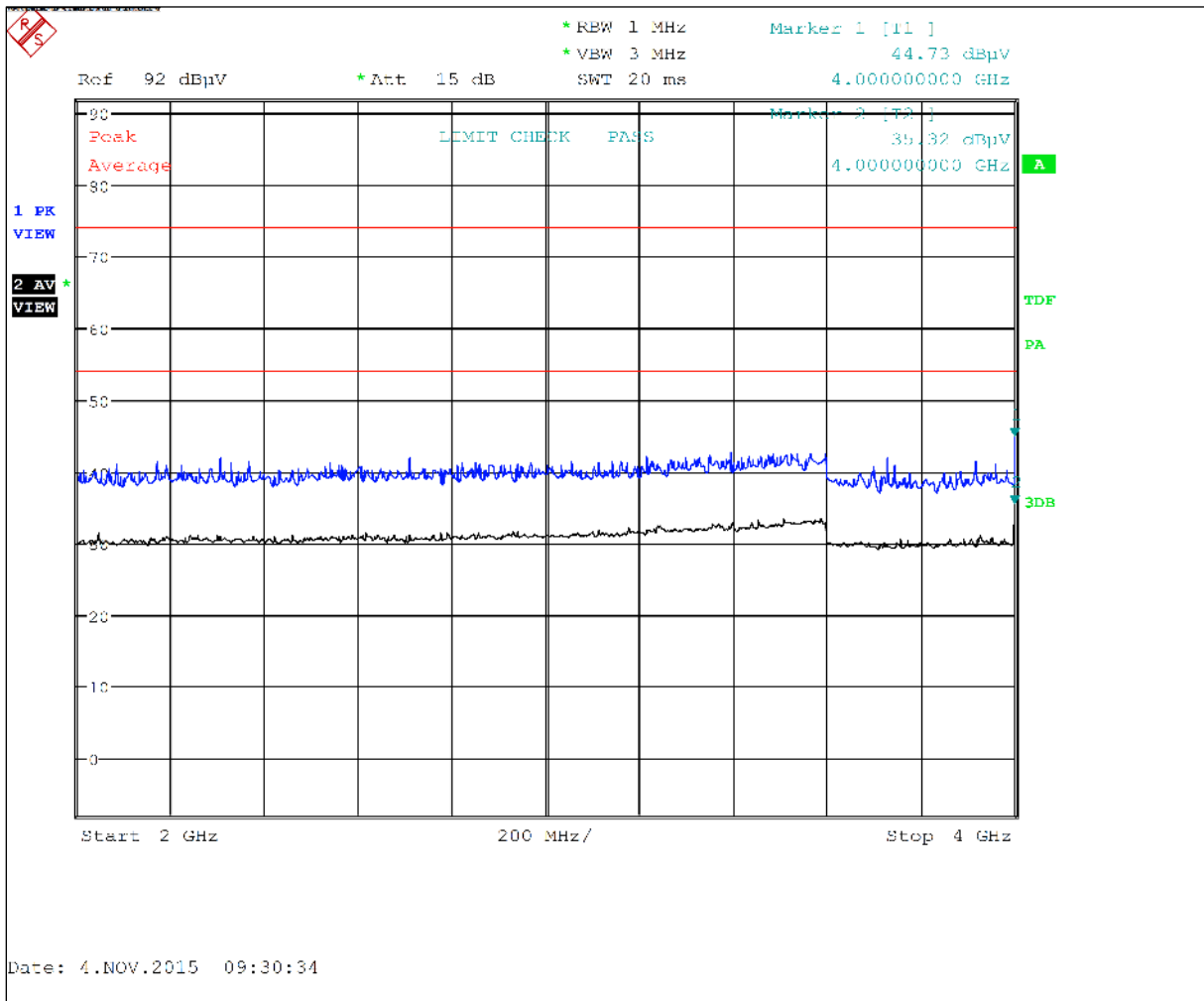

Plot 6-32: Radiated Emissions 2 GHz – 4 GHz Vertical Peak/Average

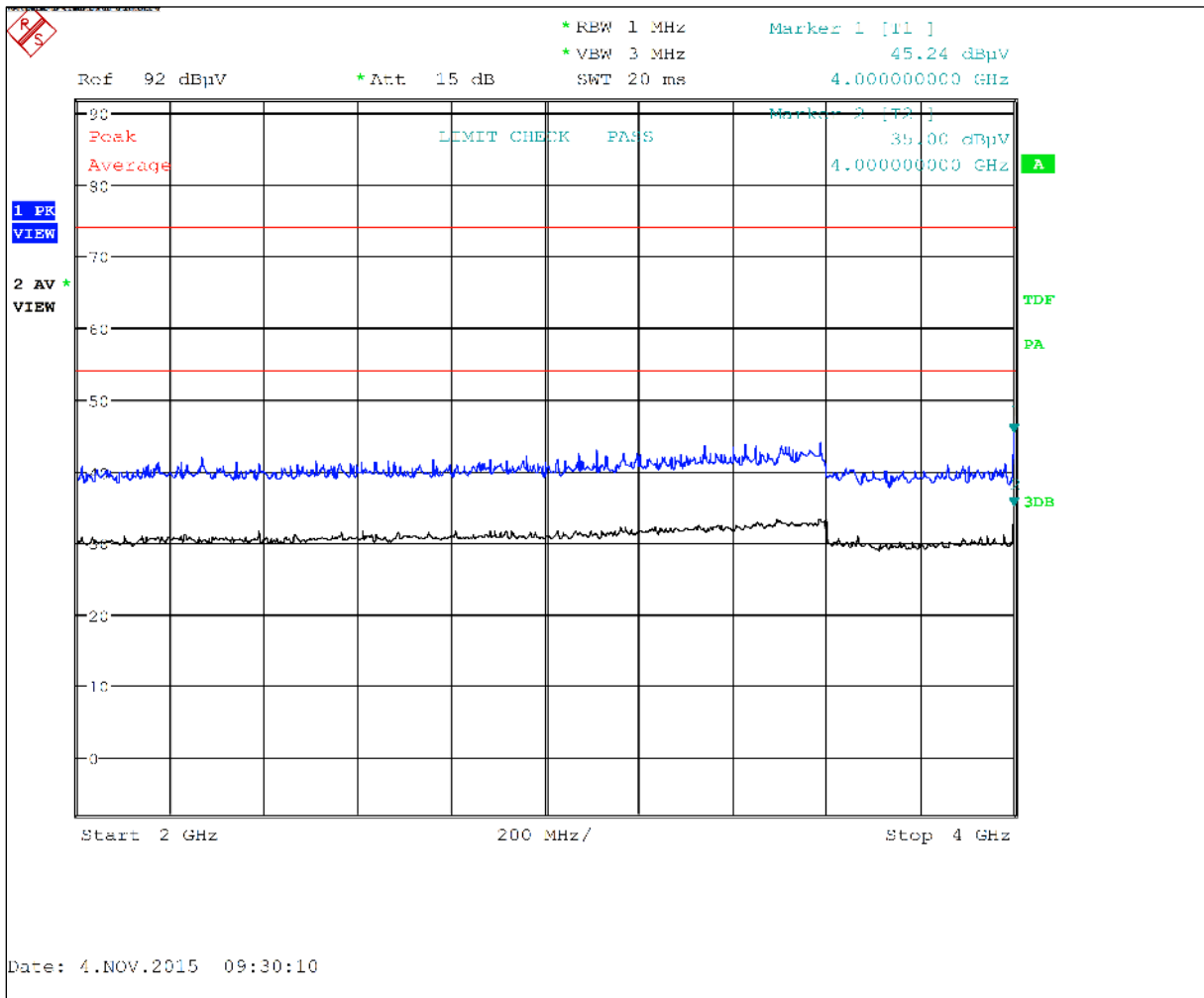

Plot 6-33: Radiated Emissions 4 GHz – 8 GHz Horizontal Peak/Average

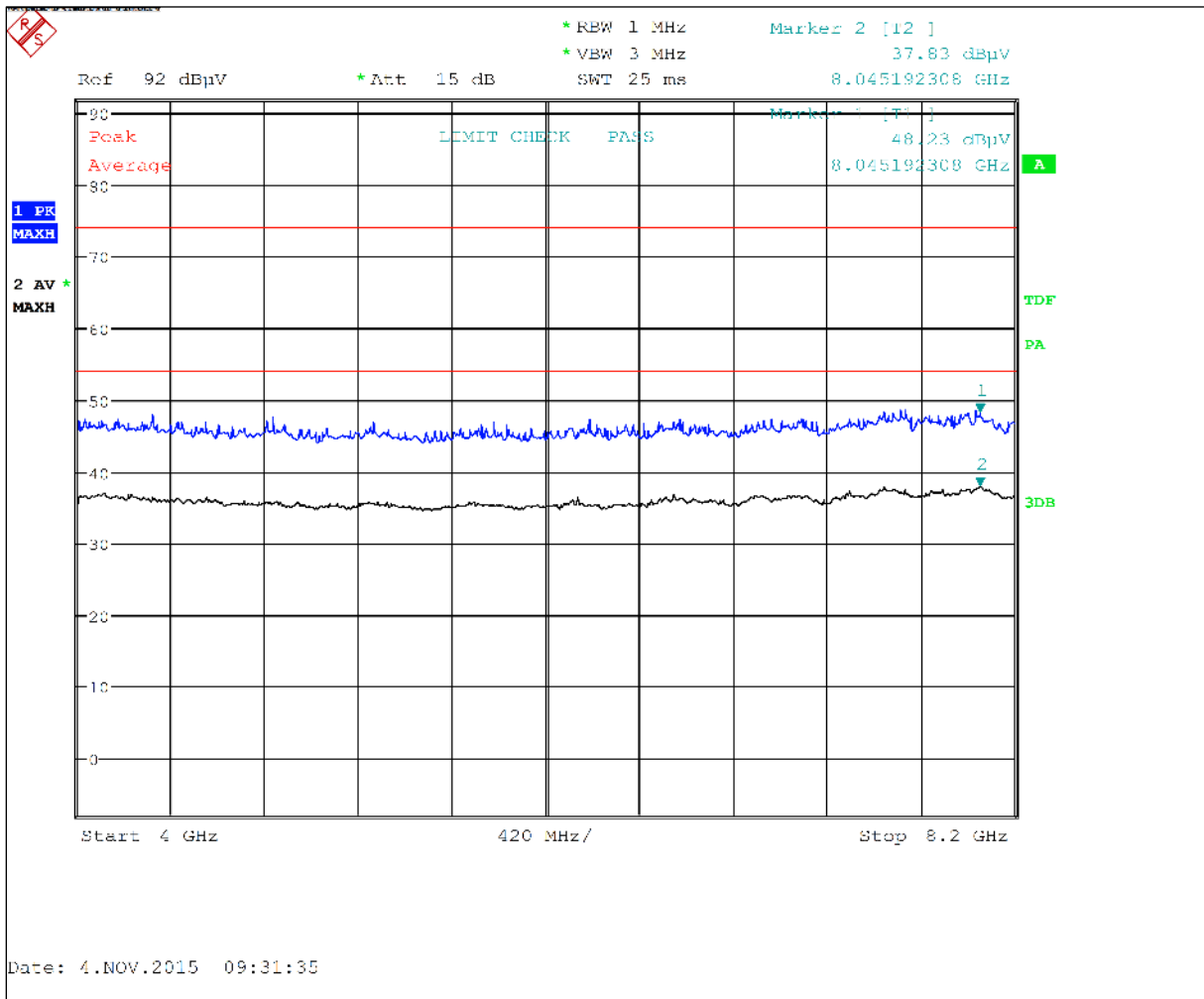

Plot 6-34: Radiated Emissions 4 GHz – 8 GHz Vertical Peak/Average

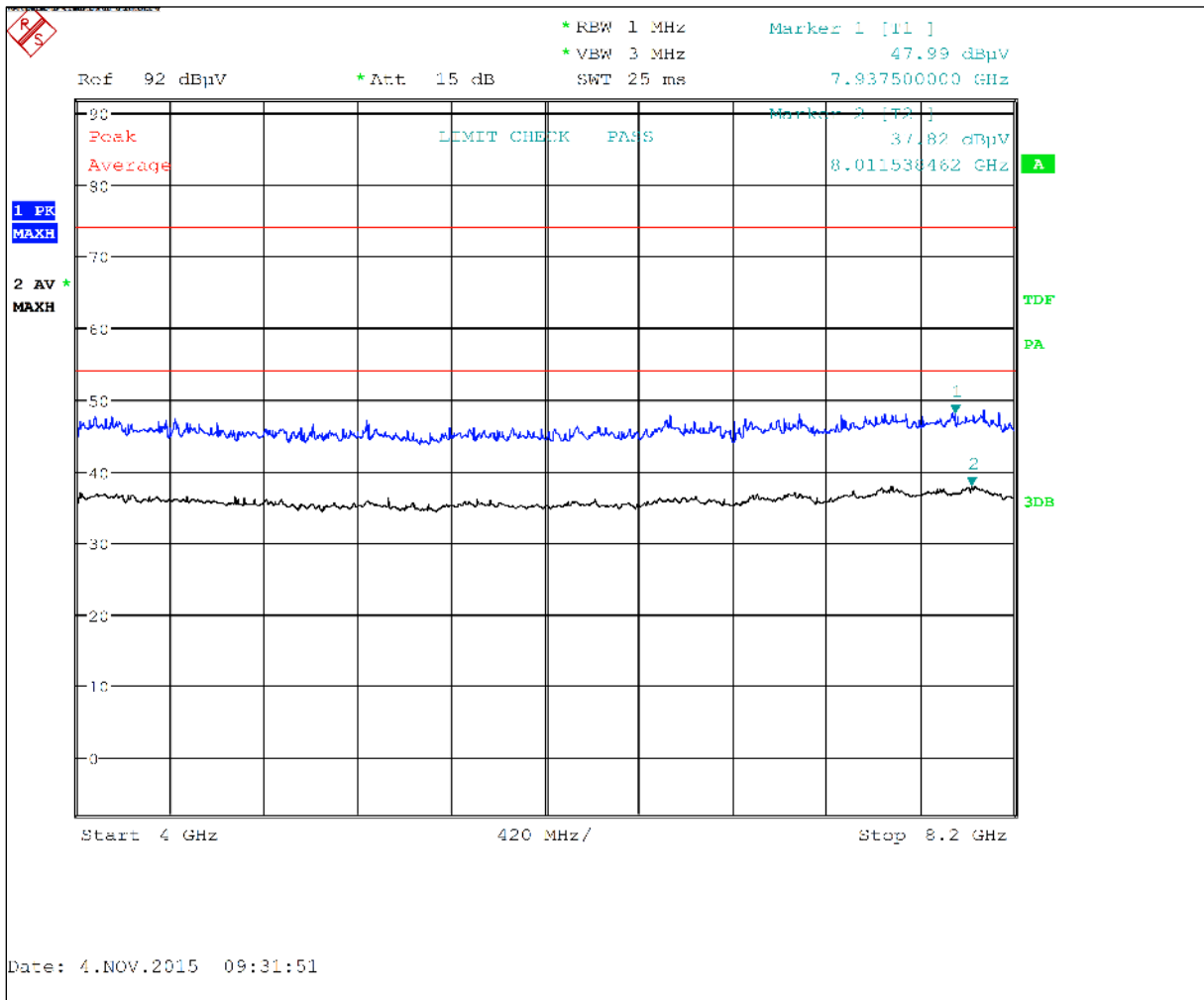

Plot 6-35: Radiated Emissions 8 GHz – 12 GHz Horizontal Peak/Average

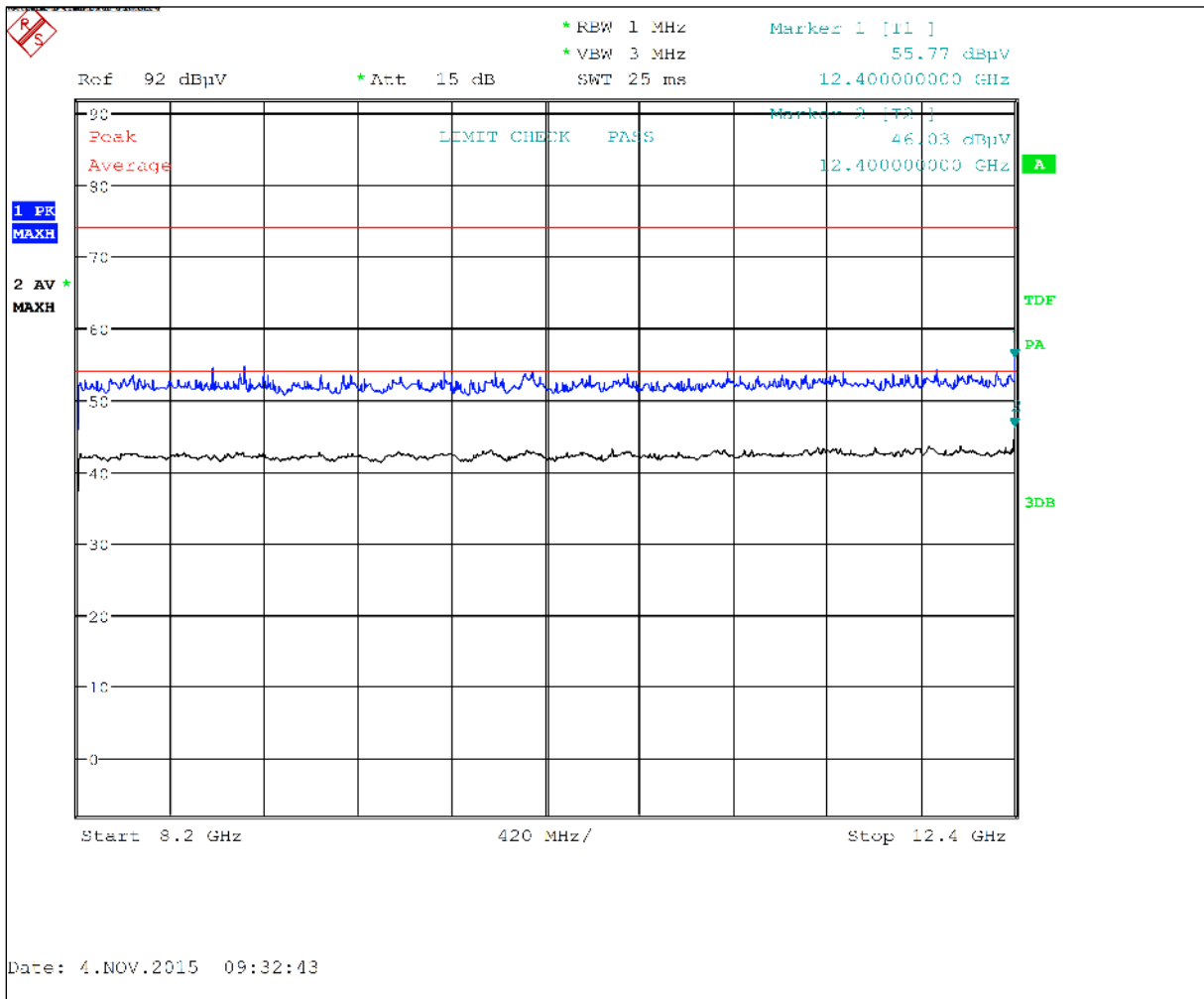

Plot 6-36: Radiated Emissions 8 GHz – 12 GHz Vertical Peak/Average

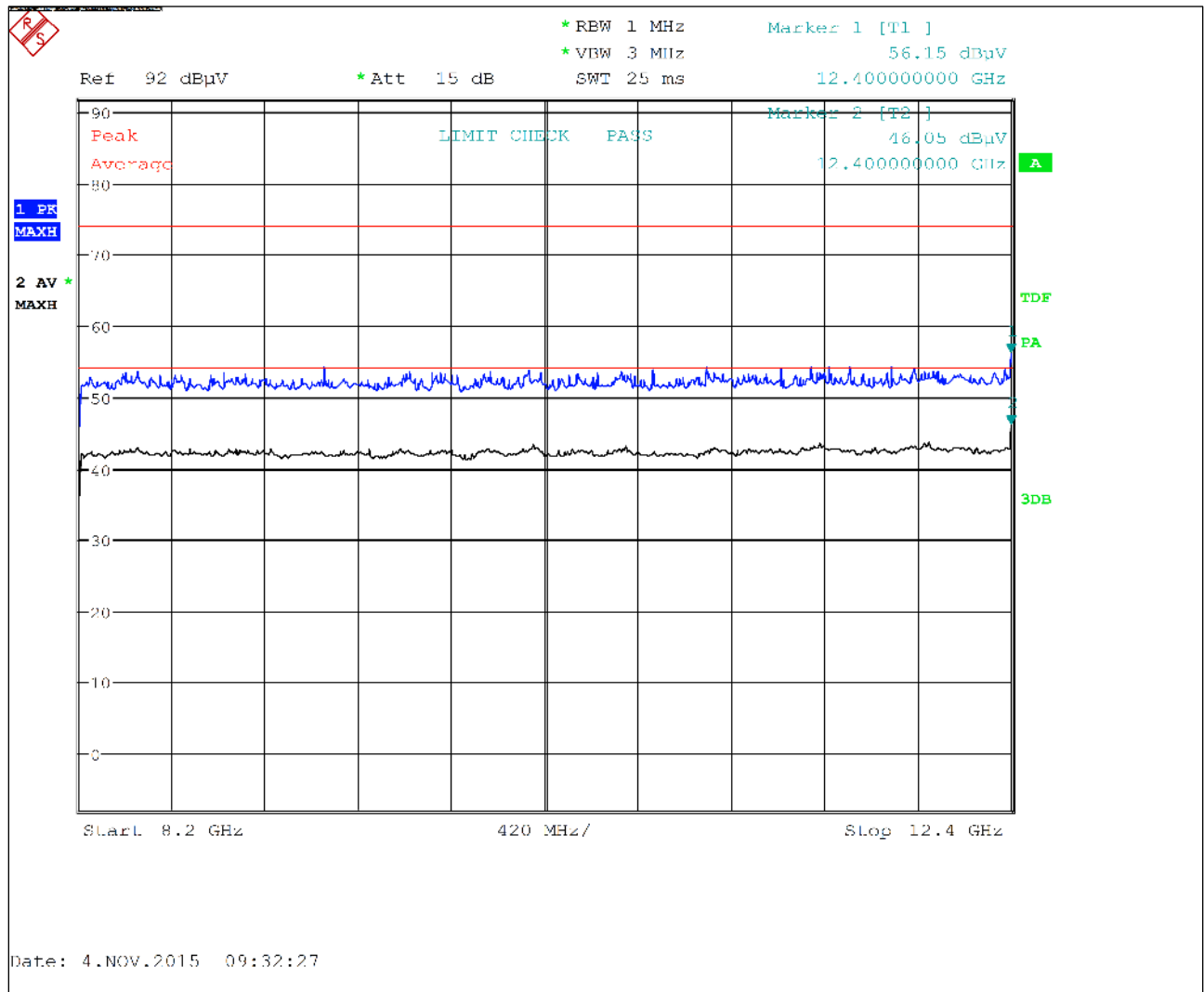

Plot 6-37: Radiated Emissions 12 GHz – 18 GHz Horizontal Peak/Average

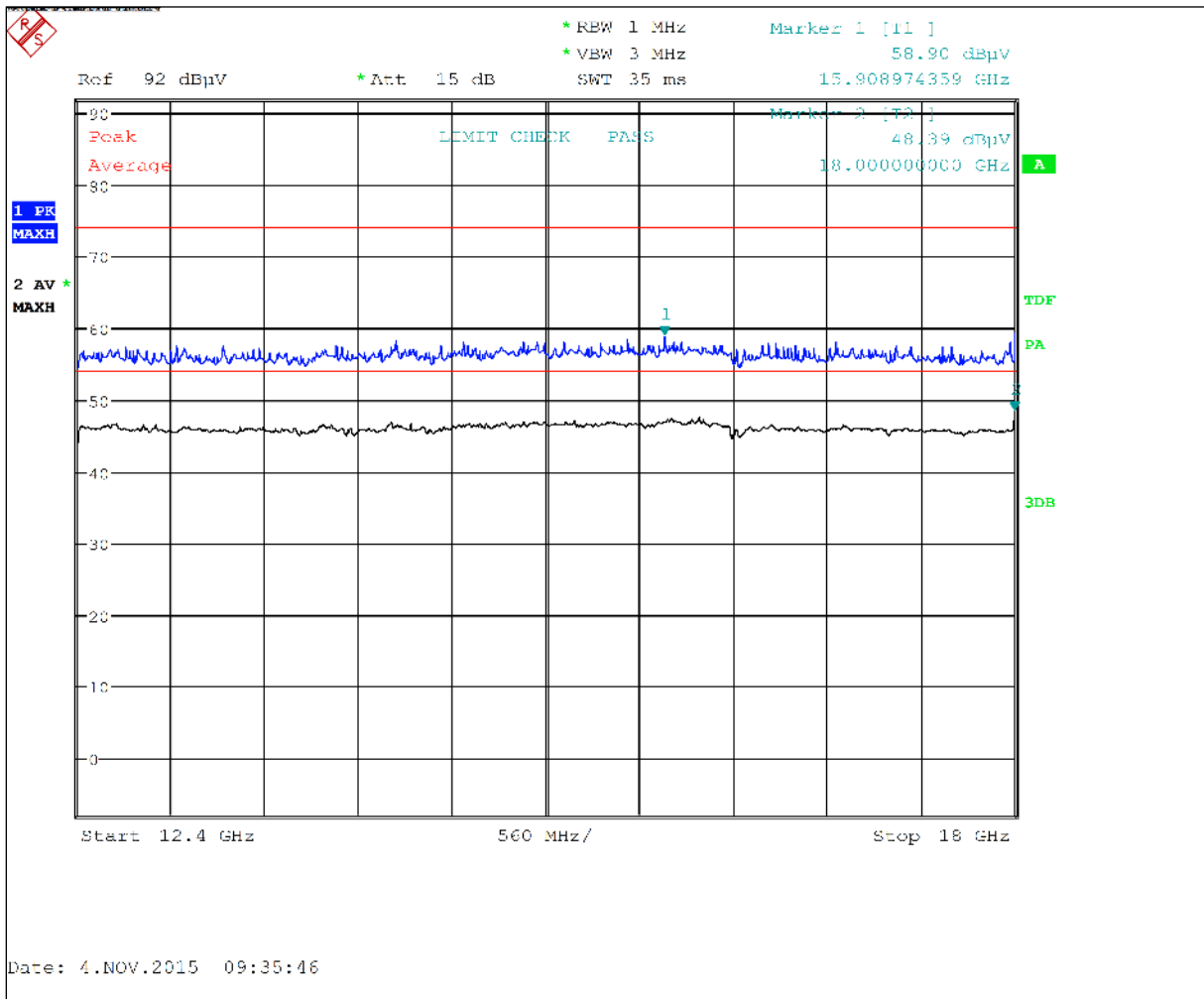

Plot 6-38: Radiated Emissions 12 GHz – 18 GHz Vertical Peak/Average

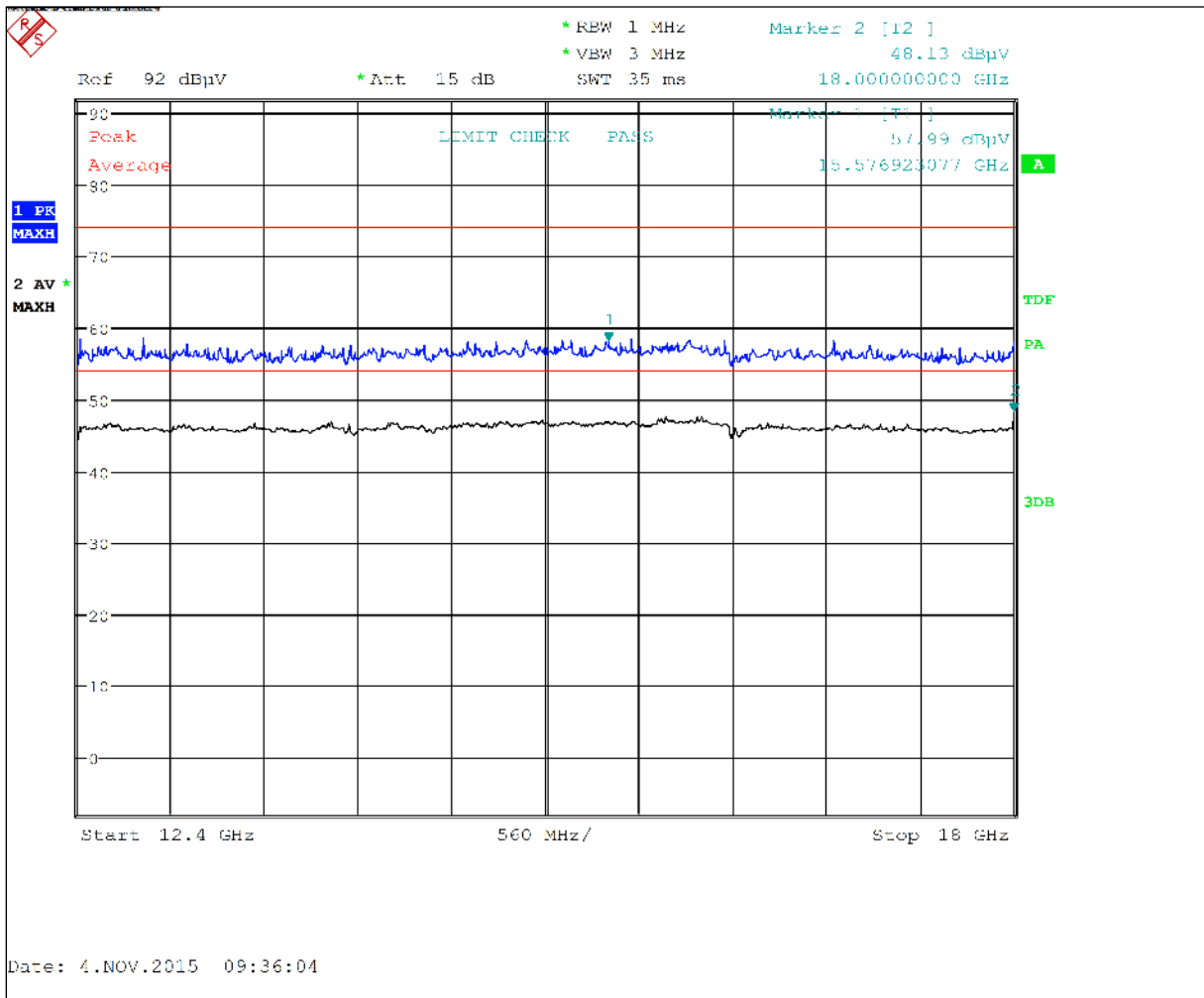

Plot 6-39: Radiated Emissions 18 GHz – 26 GHz Horizontal Peak/Average

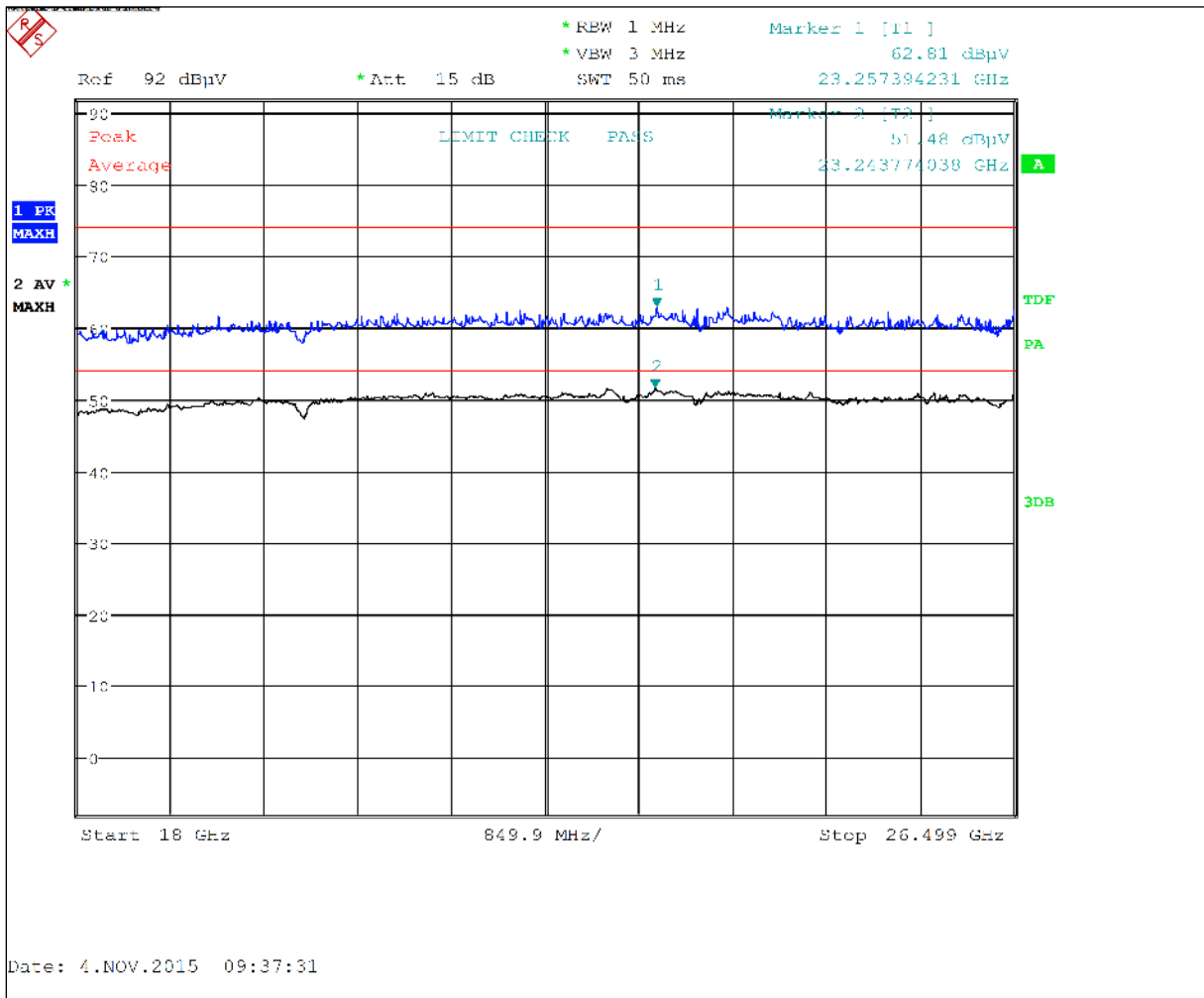

Plot 6-40: Radiated Emissions 18 GHz – 26 GHz Vertical Peak/Average

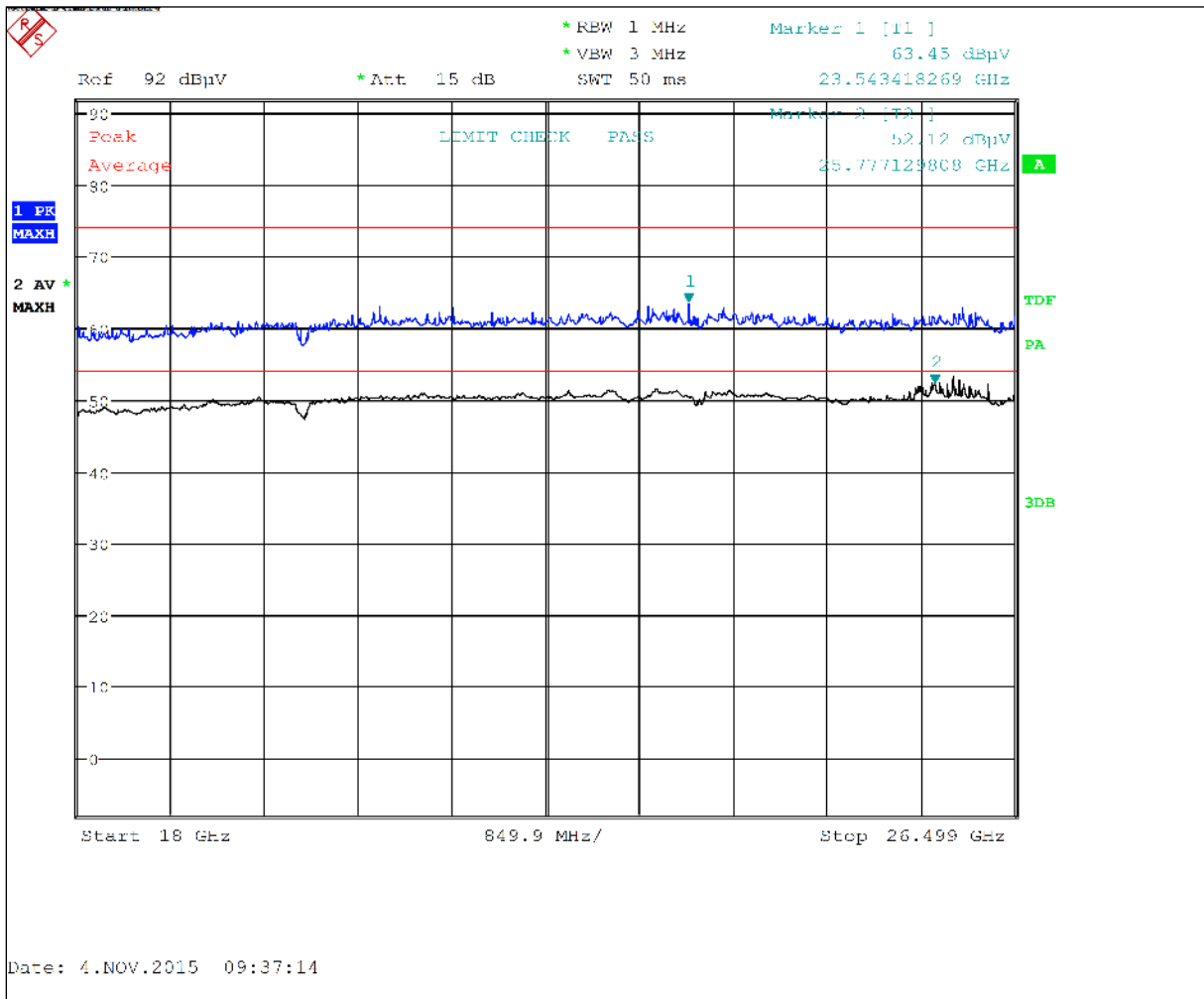

6.3.1.1 Radiated Emissions Carrier Test Data - TC#3 Steel Container

Plot 6-41: Radiated Emissions of Carrier - TC #3 Steel Container

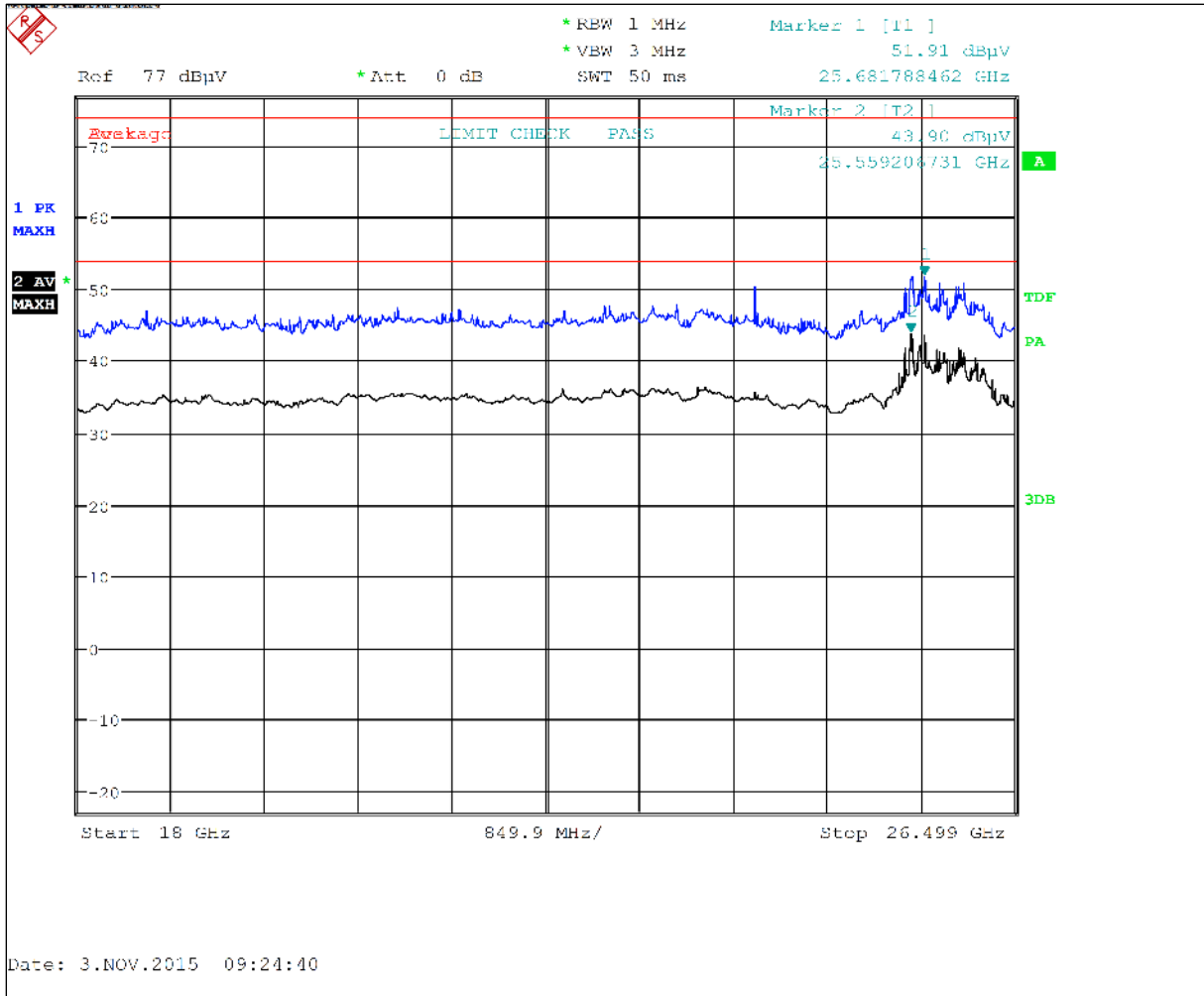
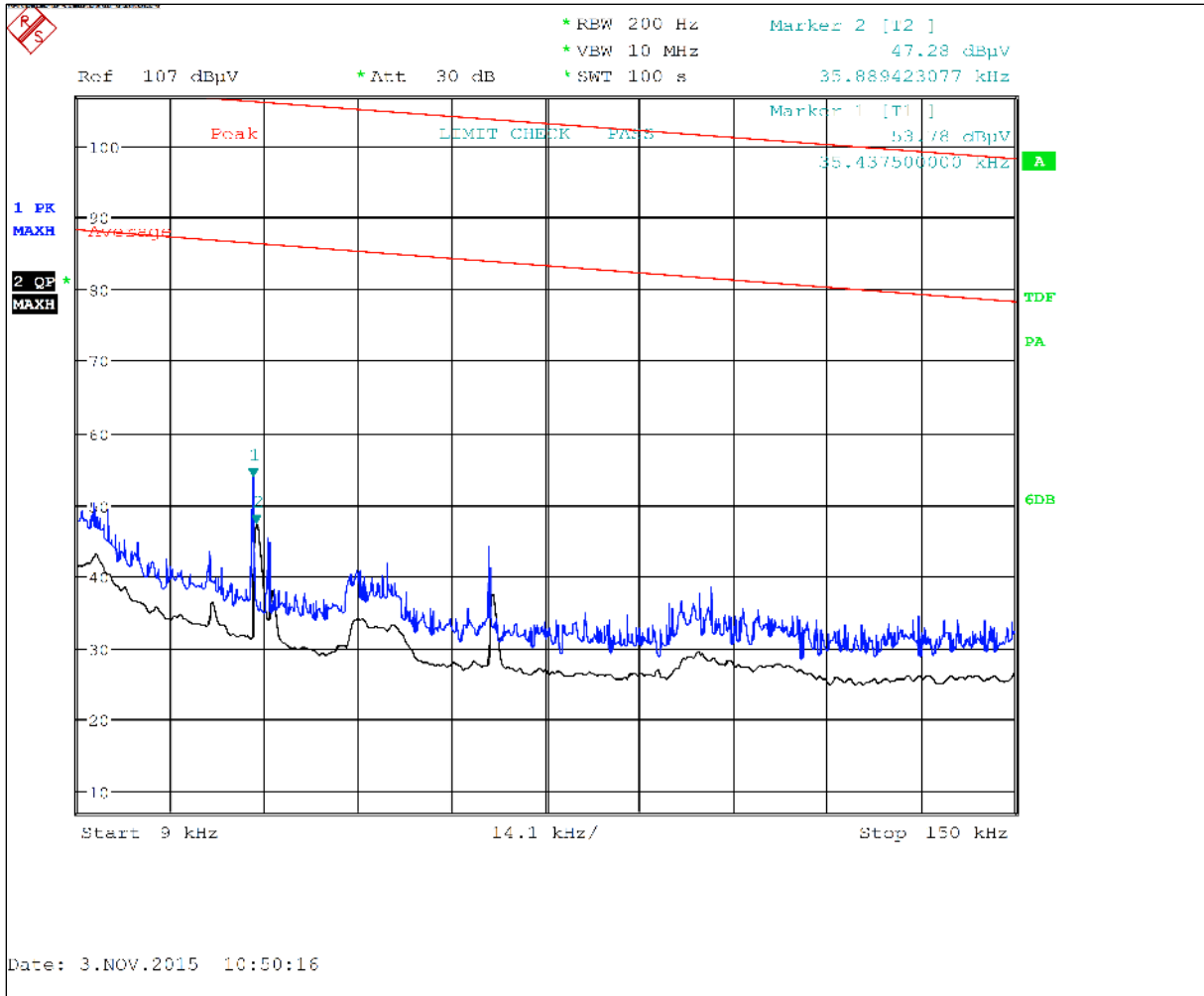

Table 6-3: Radiated Emissions of Carrier – TC #3 Steel Container

Frequency (GHz)	Detector	Test Antenna Pol	Corrected Spectrum Analyzer Level (dBuV/m)	FCC Limit (dBuV)	Margin (dB)	Corrected Spectrum Analyzer Level (dBm/MHz)	IC Limit (dBm/MHz)	Margin (dBm)
25.6817	Peak	V	51.9	74.0	-22.1	NA		
25.5592	Average	V	43.9	54.0	-10.1	-51.3	-41.3	10

6.3.1.2 Radiated Emissions Below 1 GHz Test Data – TC#3 Steel Container

Plot 6-42: Radiated Emissions Transmit – 9 kHz – 150 kHz Horizontal Peak/Average



Plot 6-43: Radiated Emissions Transmit – 9 kHz – 150 kHz Vertical Peak/Average

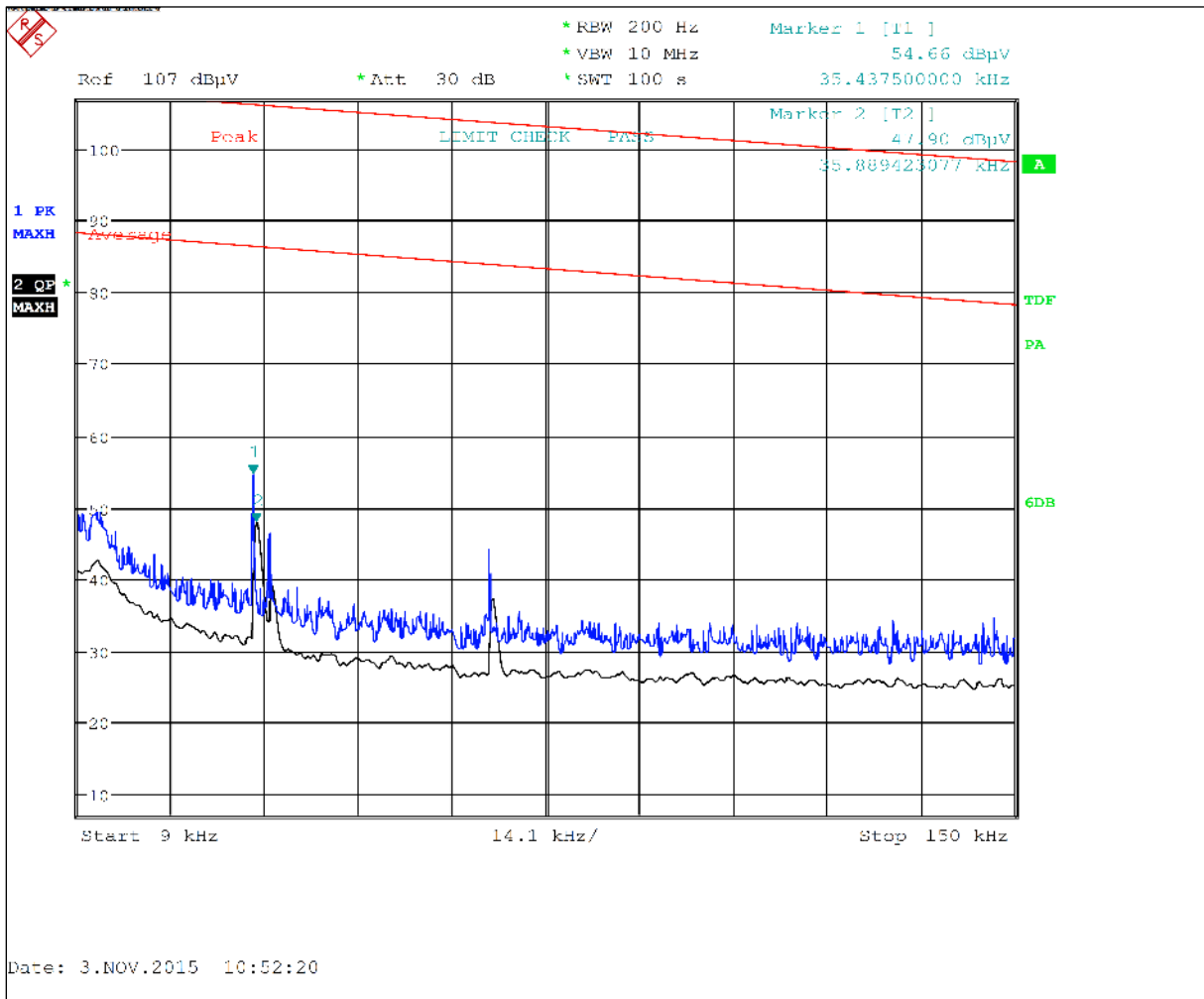

Plot 6-44: Radiated Emissions Transmit – 150 kHz – 2 MHz Horizontal Peak/Average

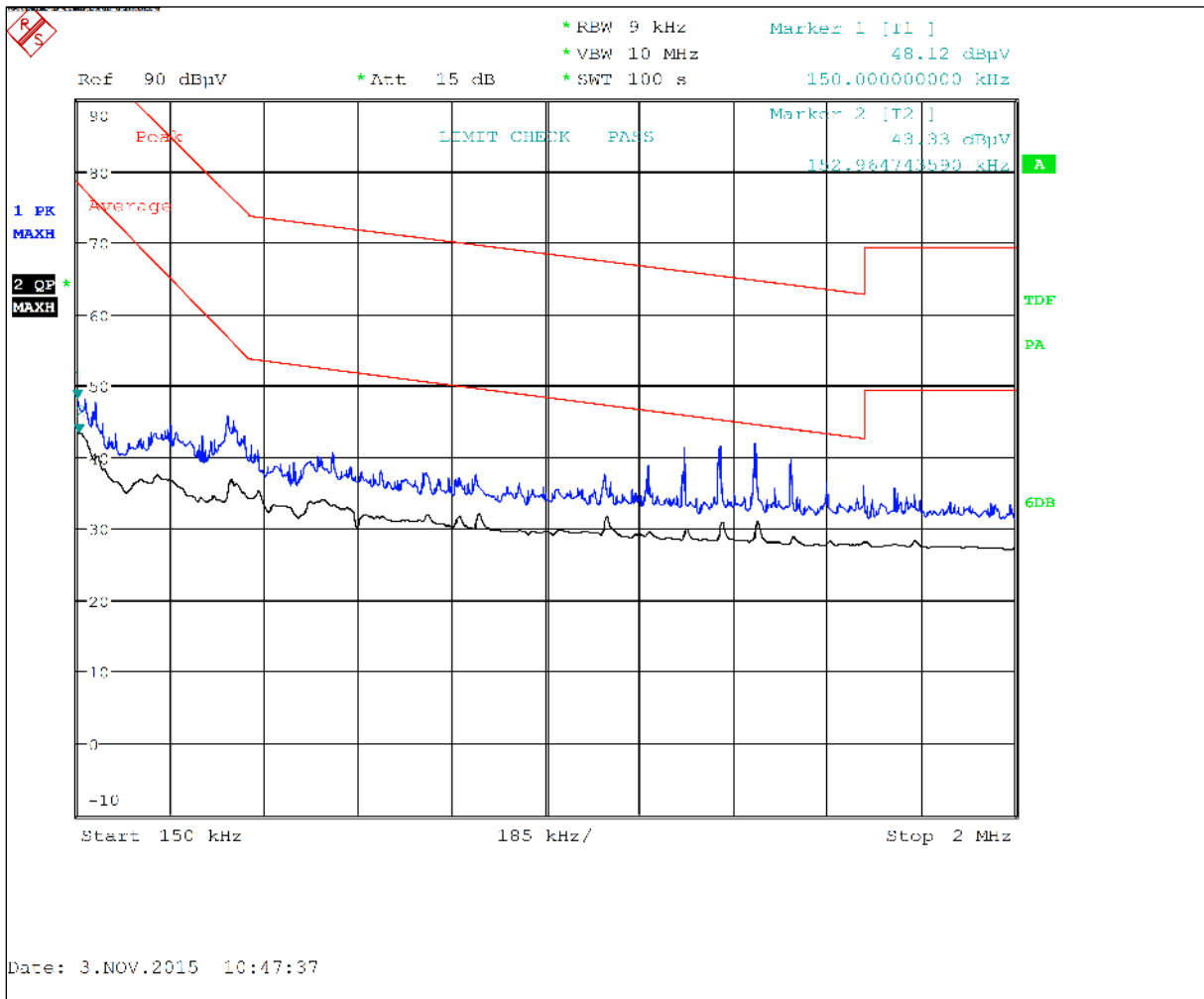

Plot 6-45: Radiated Emissions Transmit – 150 kHz – 2 MHz Vertical Peak/Average

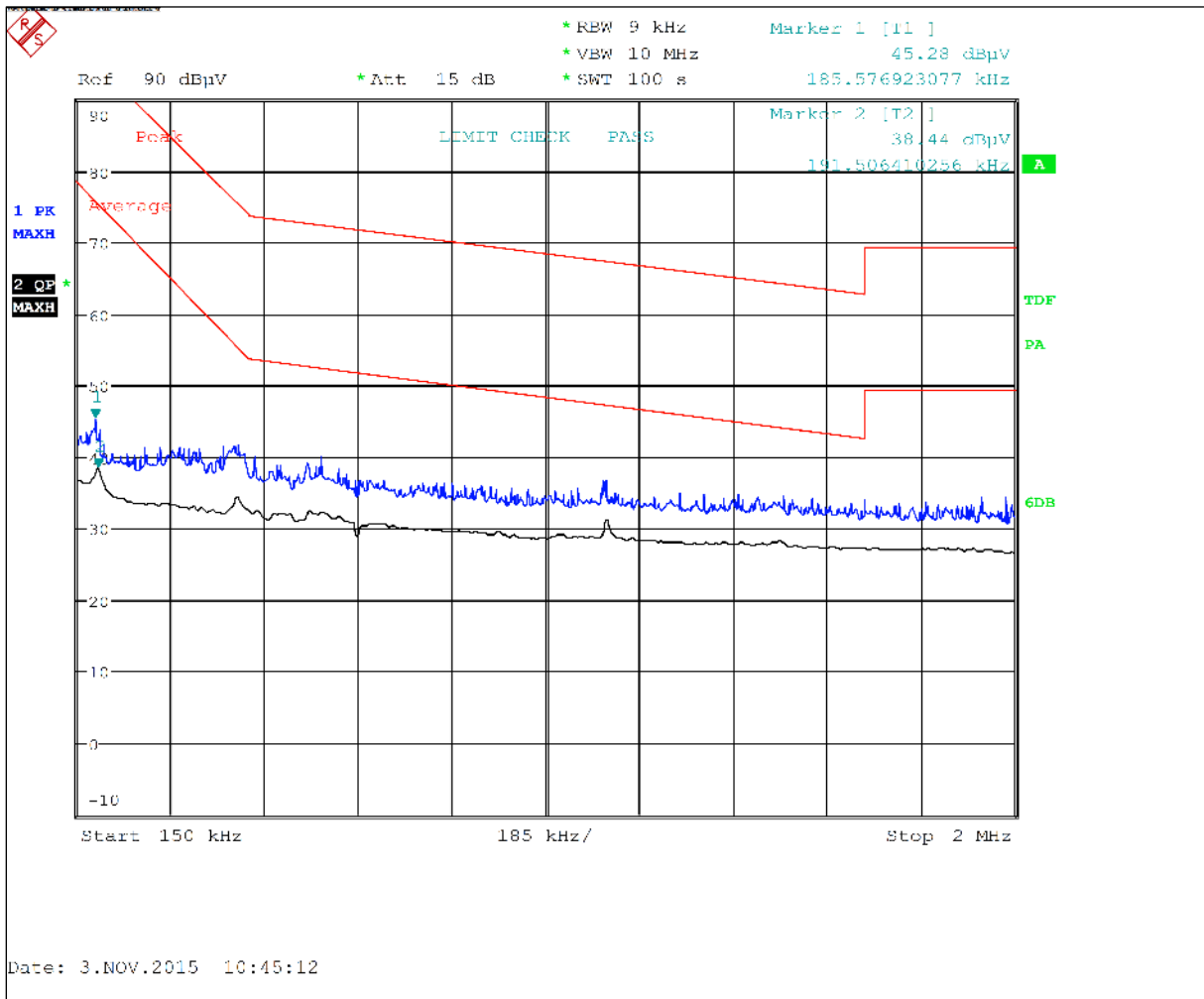

Plot 6-46: Radiated Emissions Transmit – 2 MHz – 30 MHz Horizontal Peak/Average

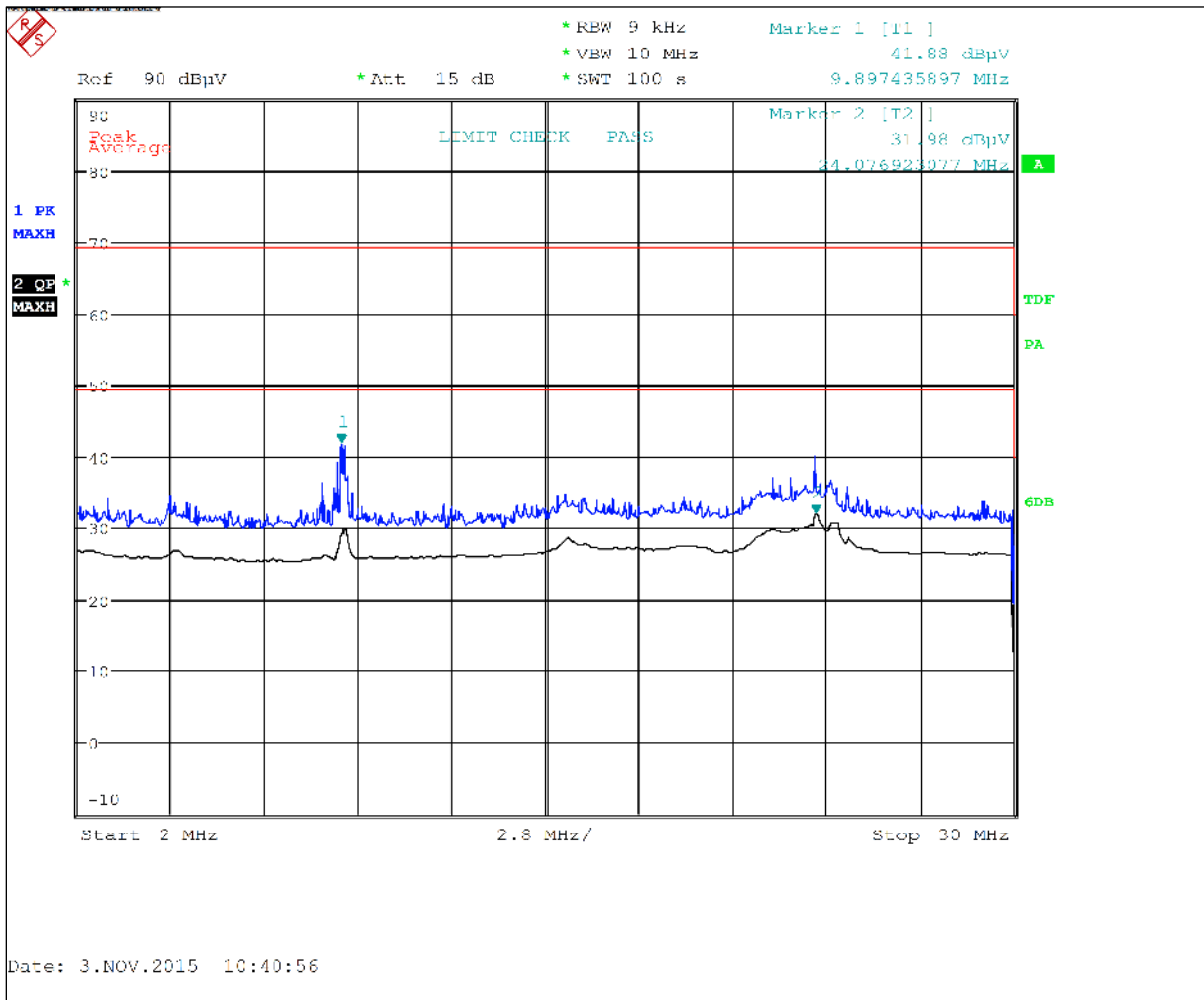

Plot 6-47: Radiated Emissions Transmit – 2 MHz – 30 MHz Vertical Peak/Average

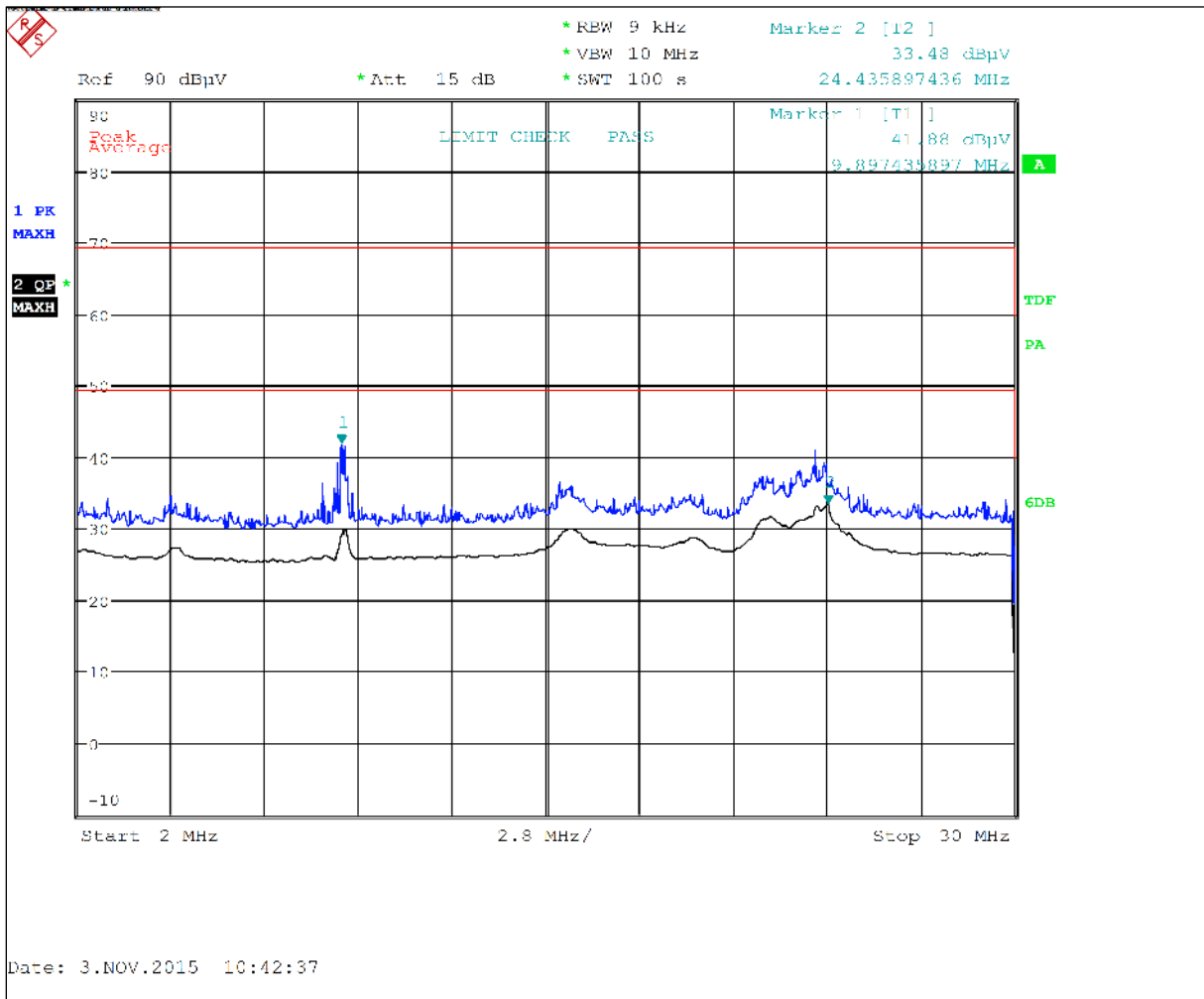

Plot 6-48: Radiated Emissions Transmit – 30 MHz – 1 GHz Horizontal Peak/Average

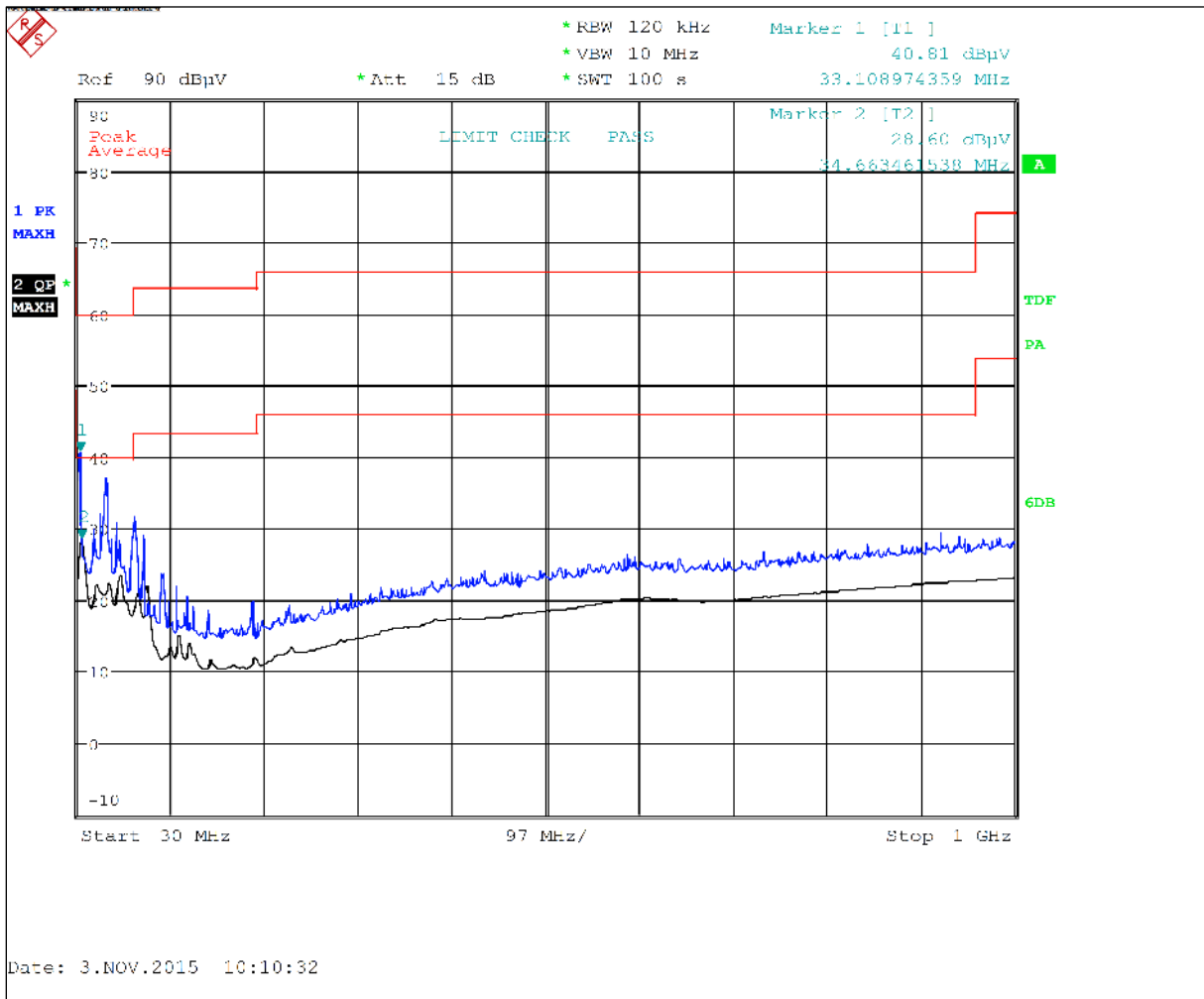

Plot 6-49: Radiated Emissions Transmit – 30 MHz – 1 GHz Vertical Peak/Average

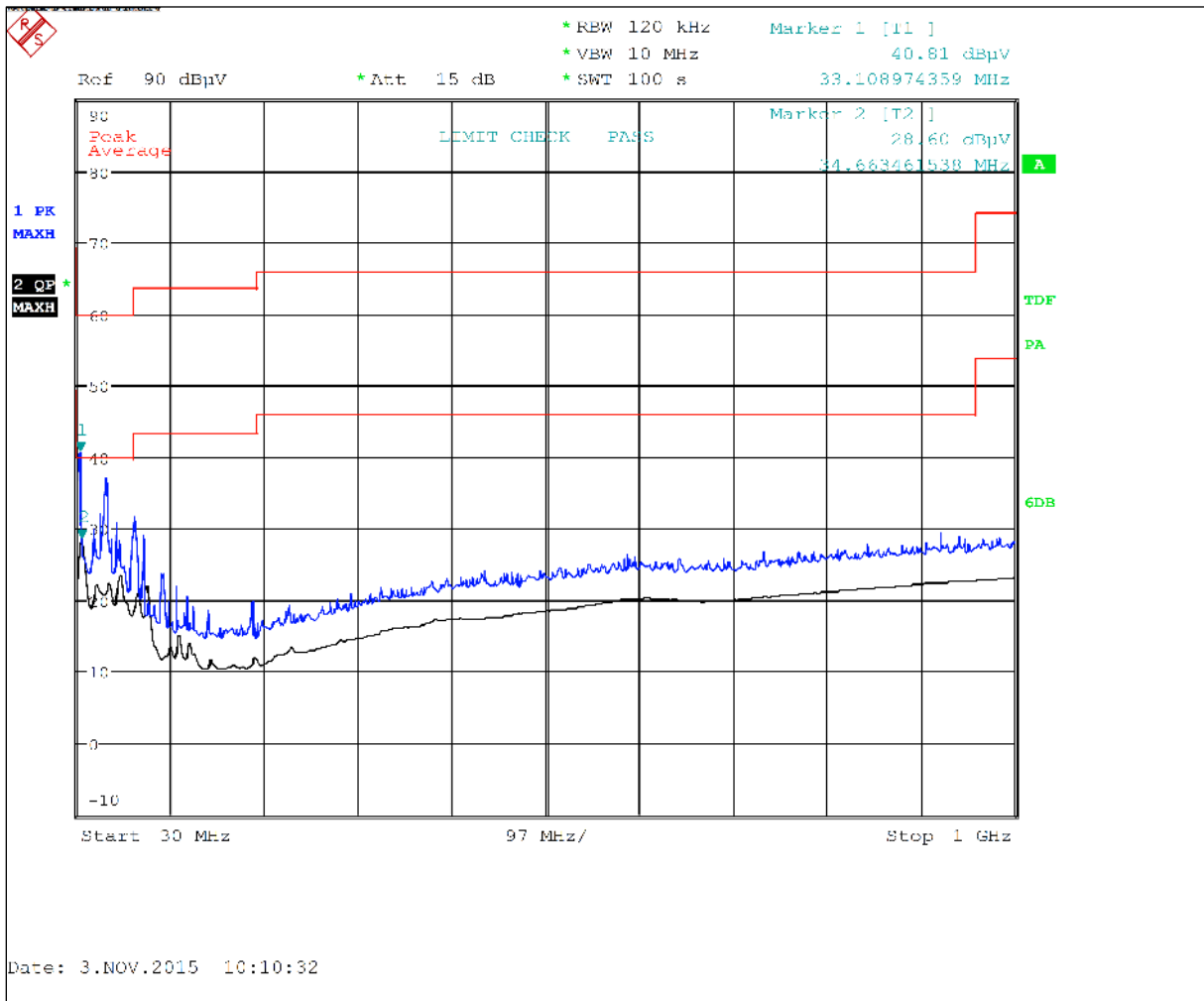

Note: Unwanted emissions were investigated as a digital device (other than harmonics) as required by 15.33(a)(3).

6.3.1.3 Radiated Emissions 1 GHz – 26 GHz Test Data – TC#3 Steel Container

Plot 6-50: Radiated Emissions 1 GHz – 2 GHz Horizontal Peak/Average

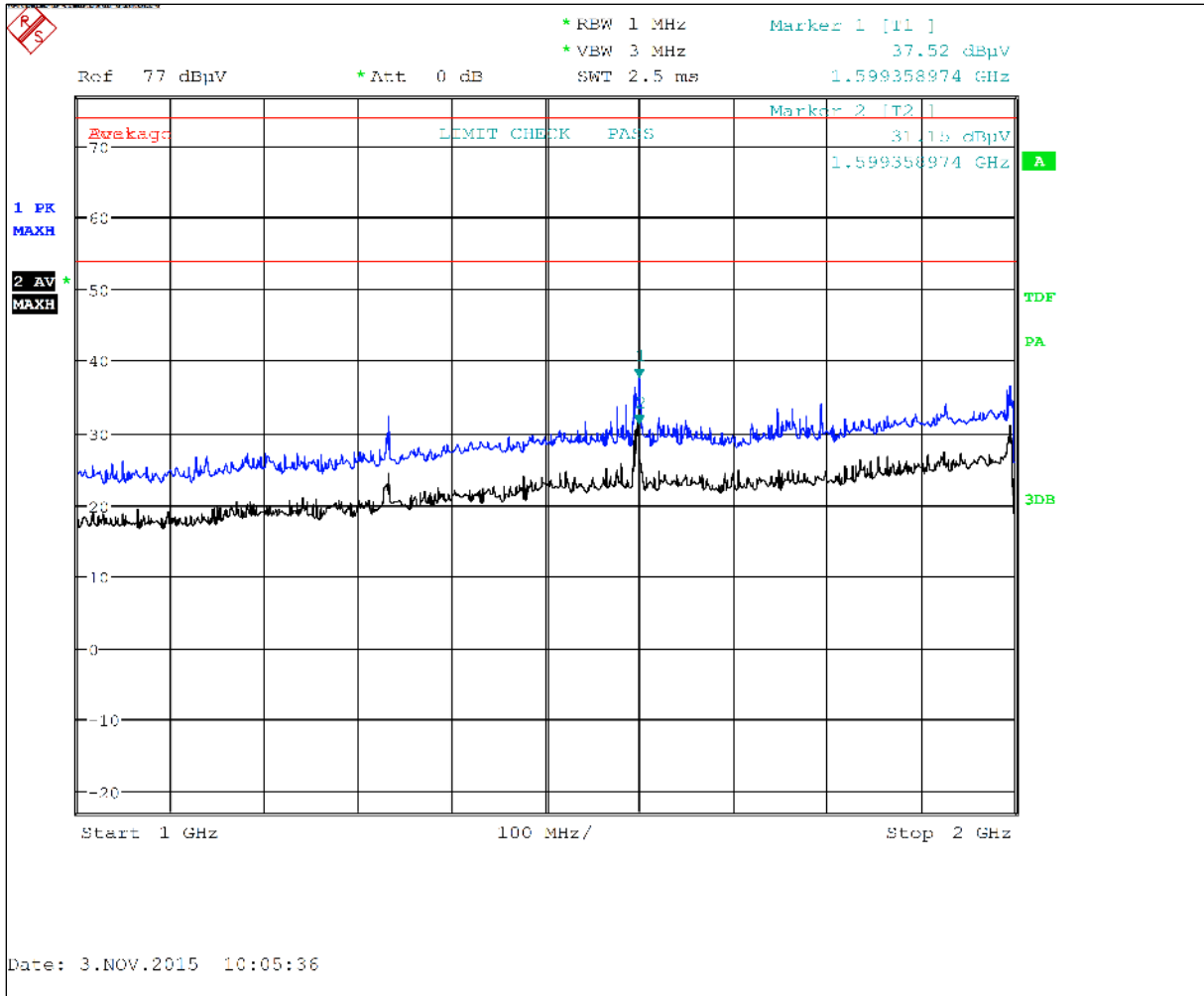

Plot 6-51: Radiated Emissions 1 GHz – 2 GHz Vertical Peak/Average

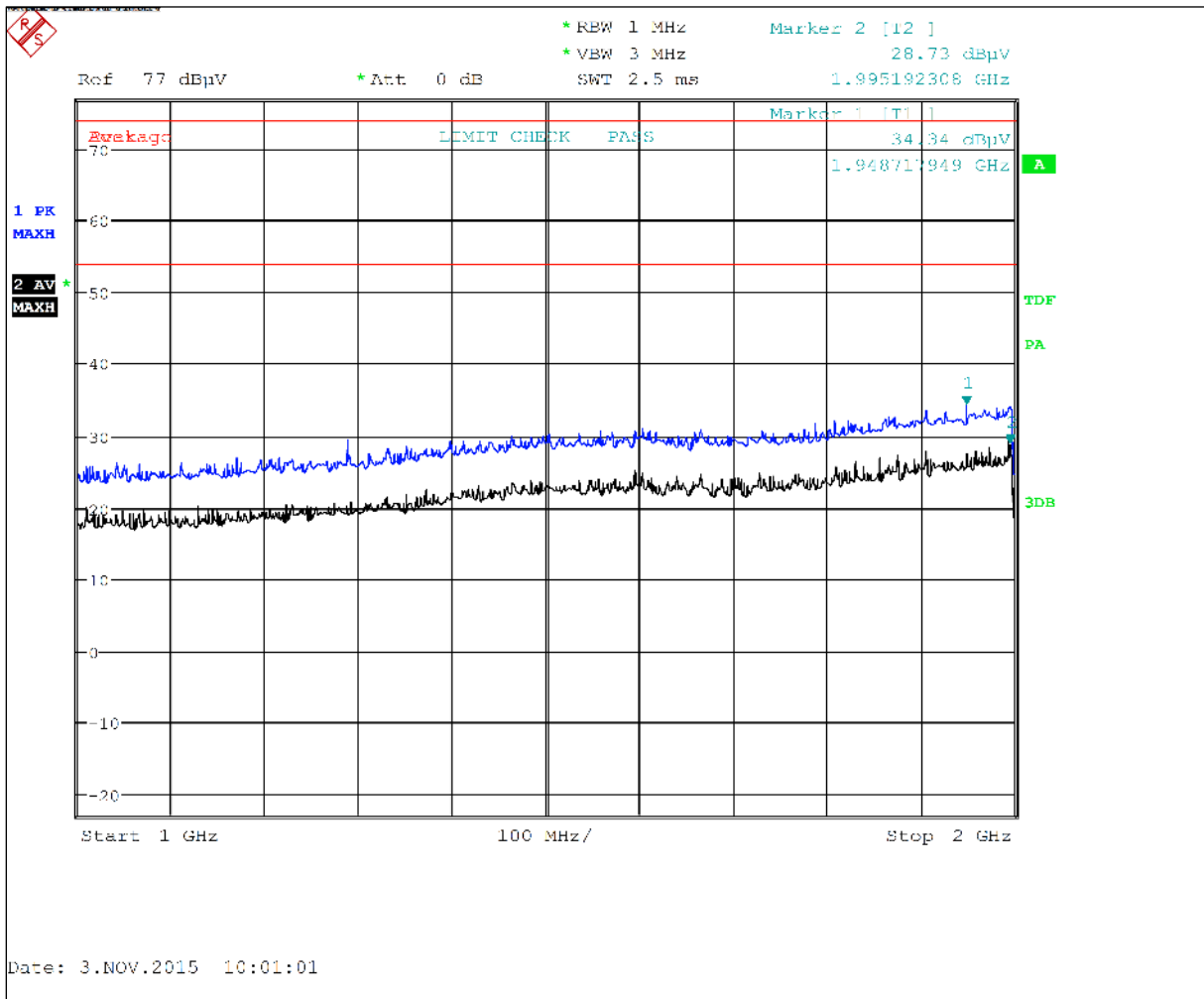

Plot 6-52: Radiated Emissions 2 GHz – 4 GHz Horizontal Peak/Average

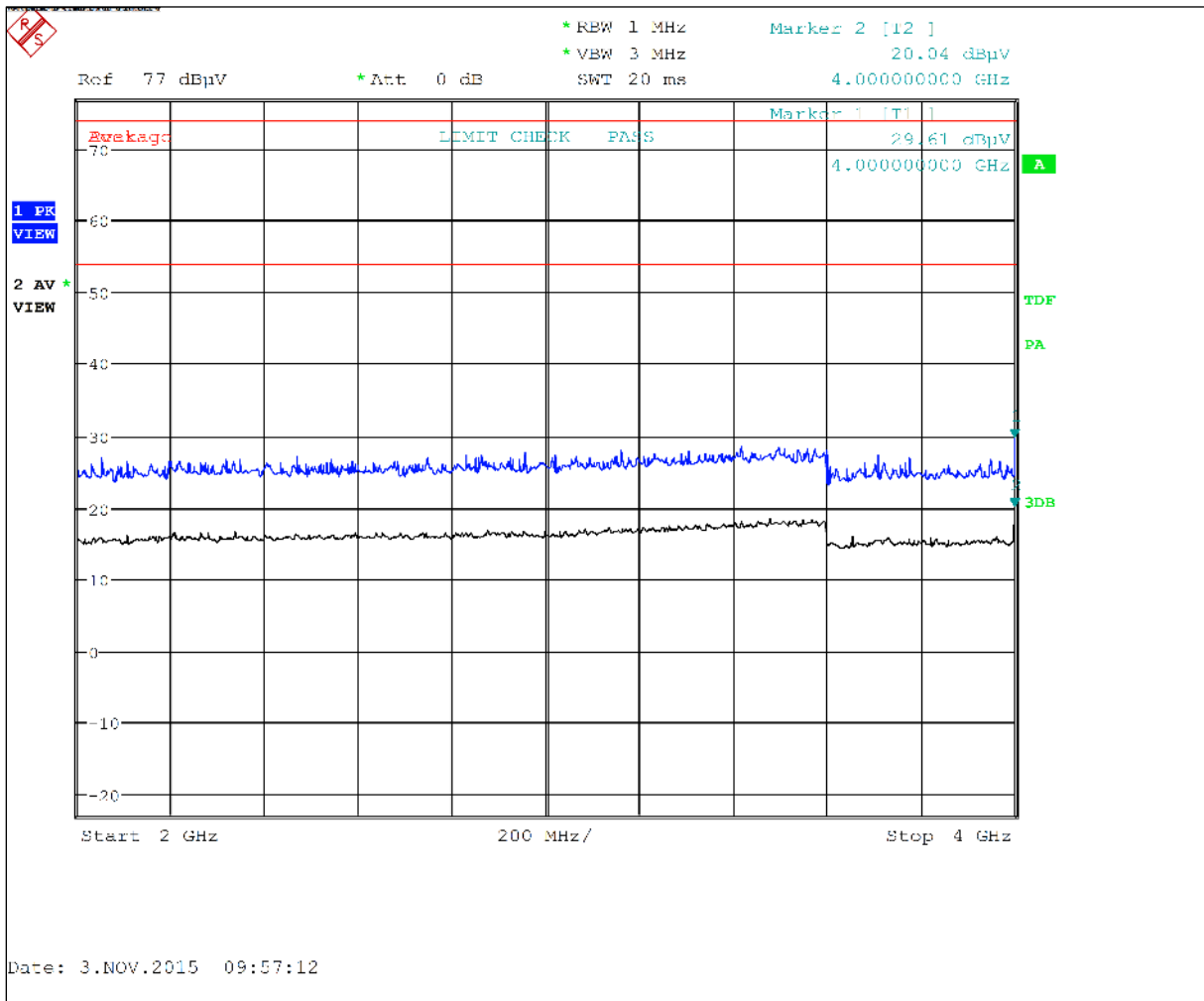

Plot 6-53: Radiated Emissions 2 GHz – 4 GHz Vertical Peak/Average

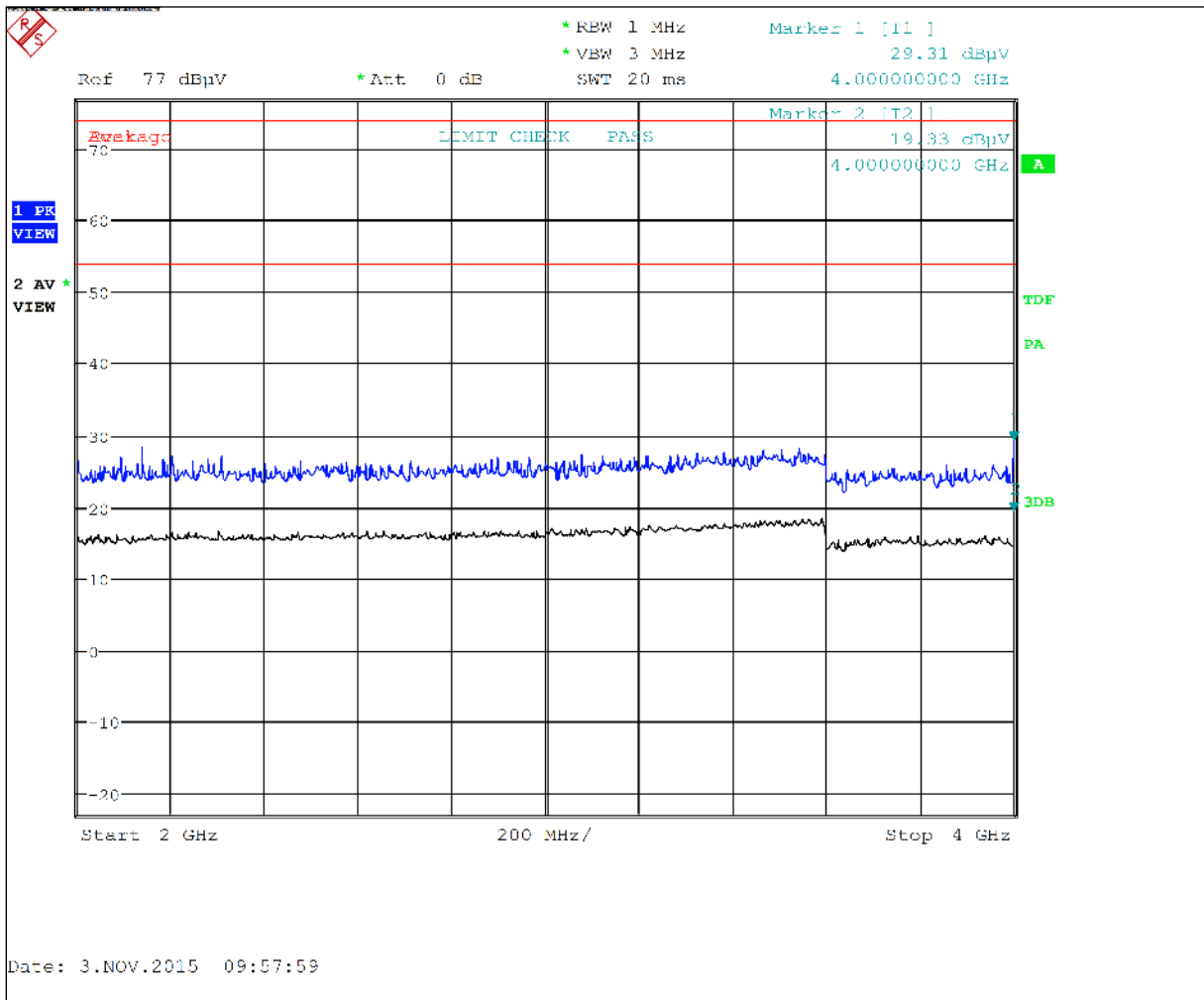

Plot 6-54: Radiated Emissions 4 GHz – 8 GHz Horizontal Peak/Average

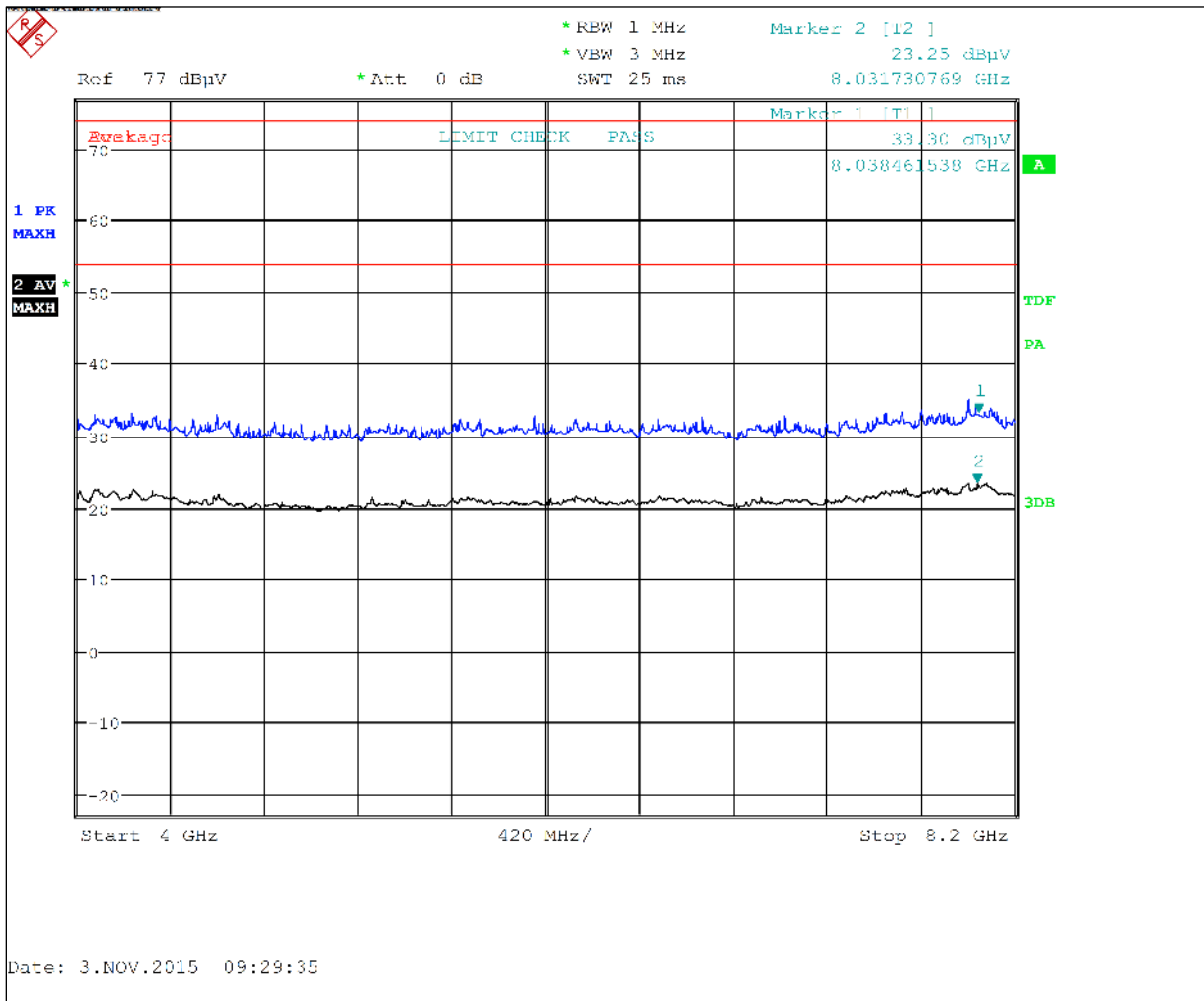

Plot 6-55: Radiated Emissions 4 GHz – 8 GHz Vertical Peak/Average

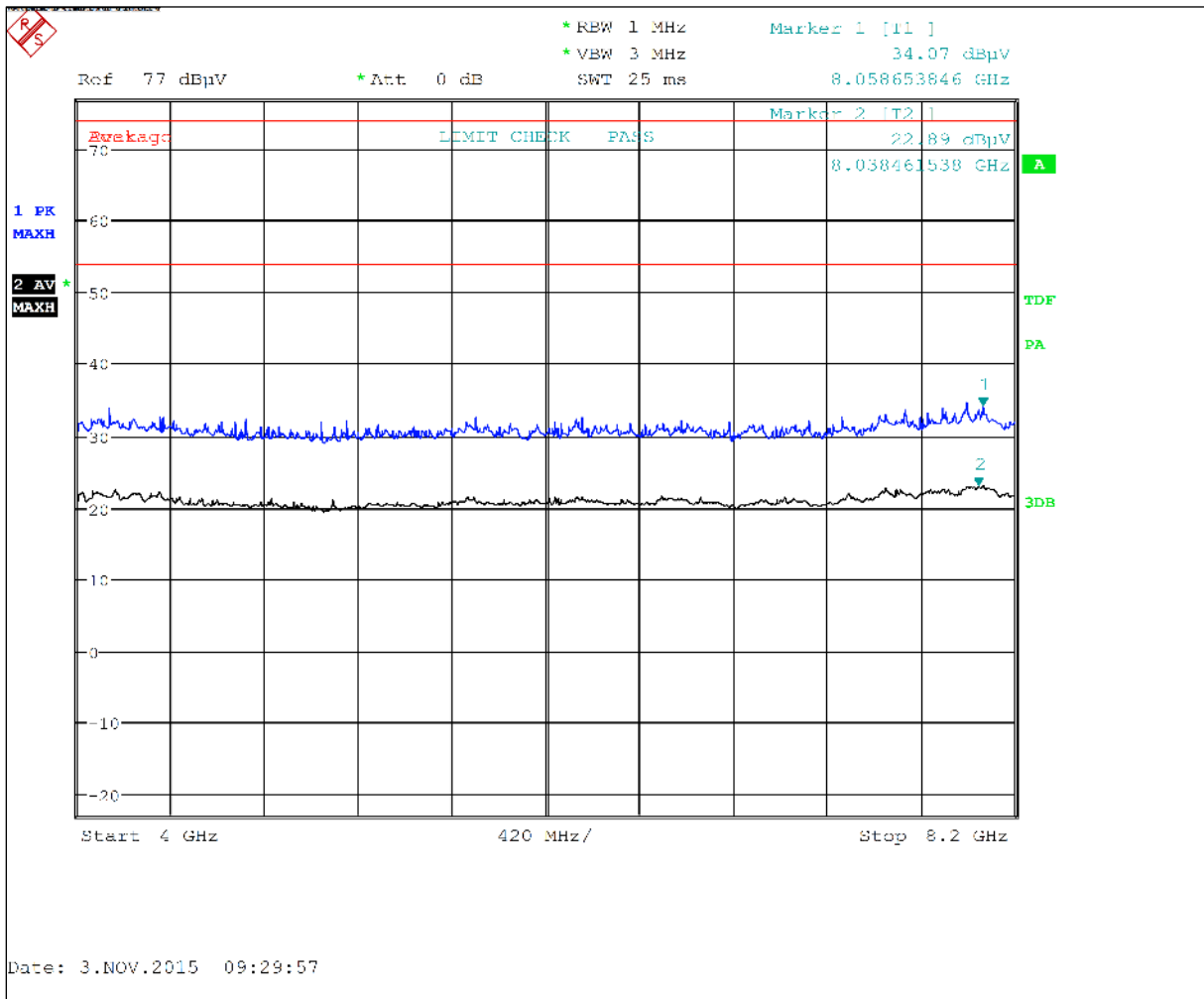

Plot 6-56: Radiated Emissions 8 GHz – 12 GHz Horizontal Peak/Average

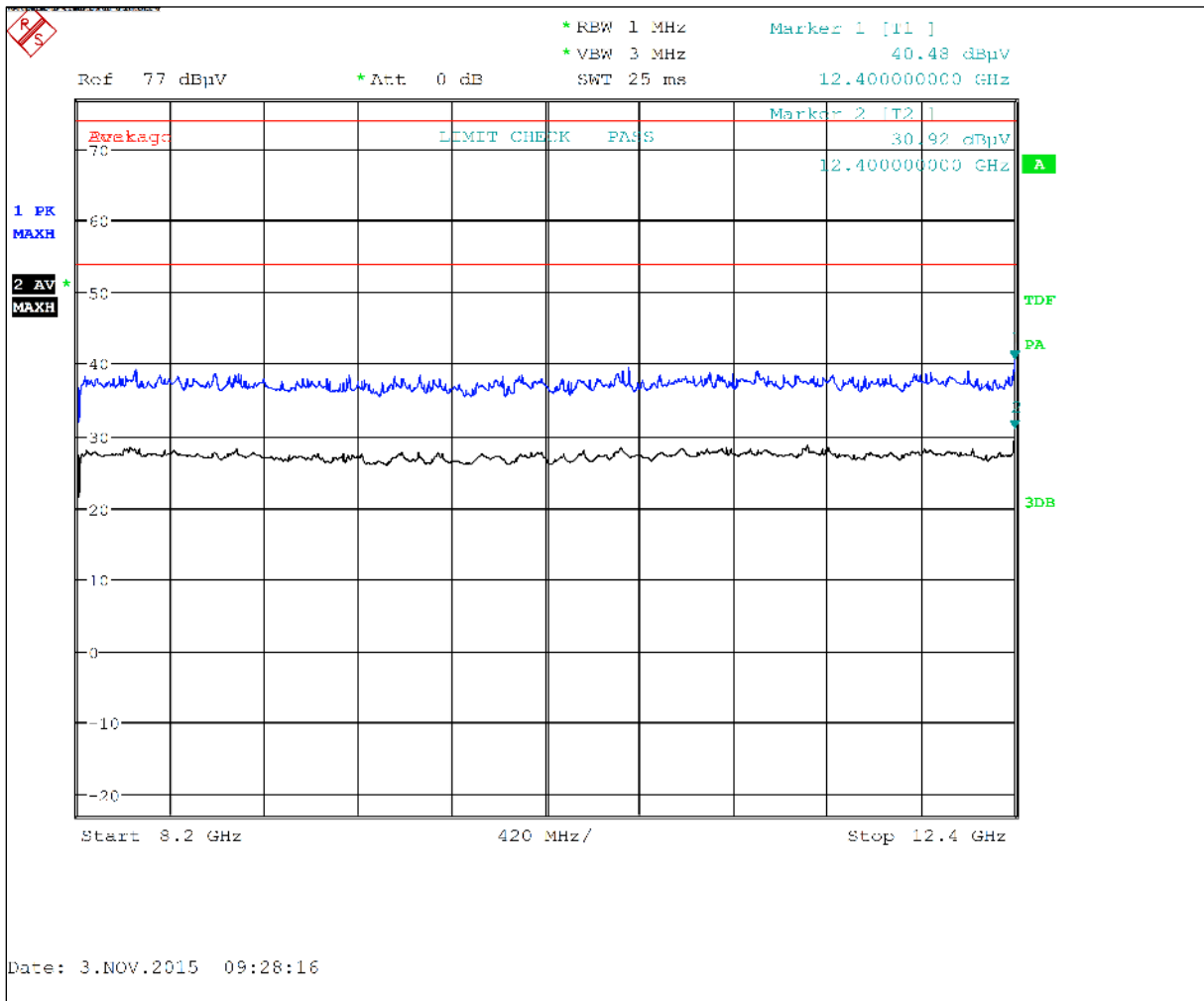

Plot 6-57: Radiated Emissions 8 GHz – 12 GHz Vertical Peak/Average

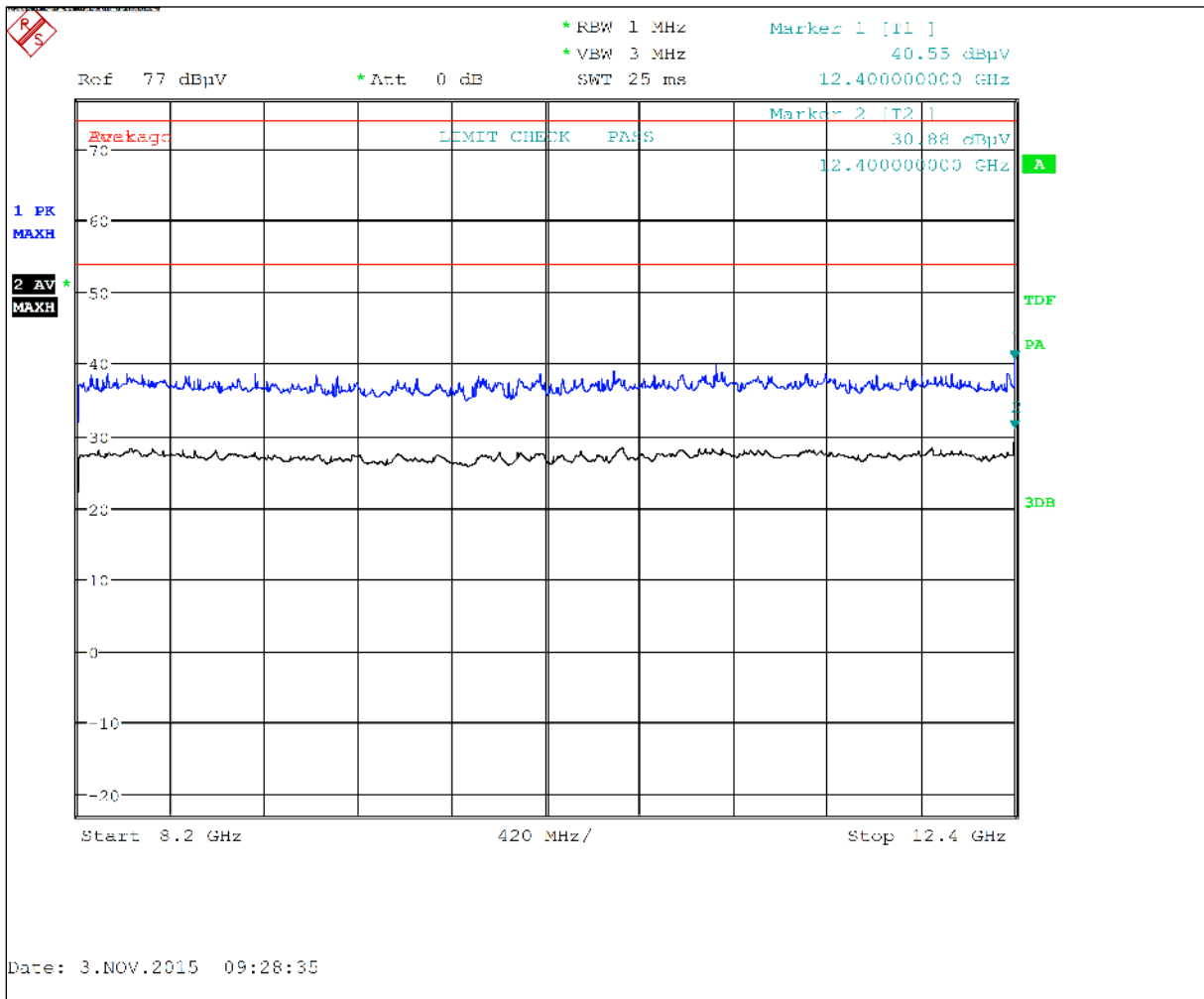

Plot 6-58: Radiated Emissions 12 GHz – 18 GHz Horizontal Peak/Average

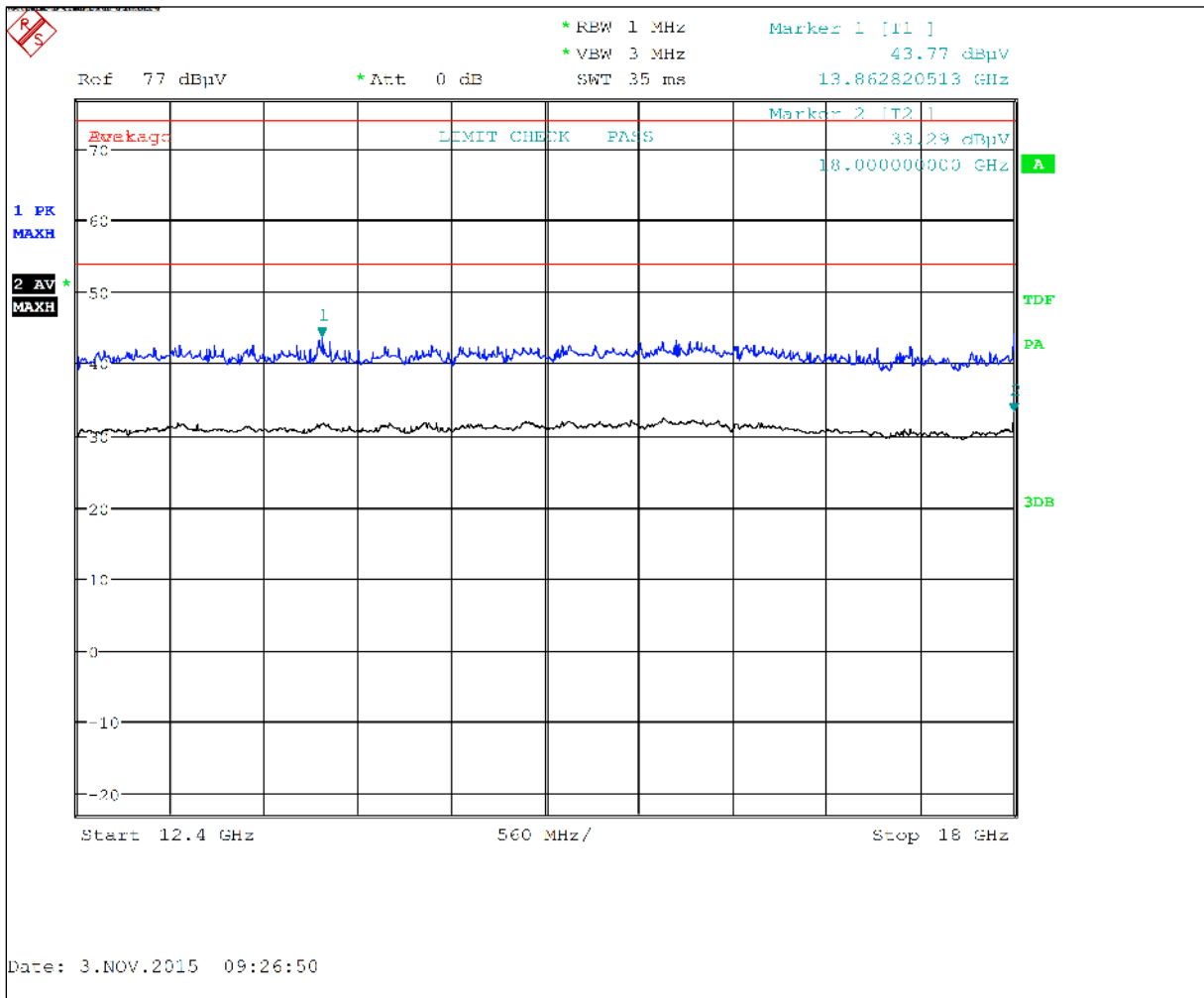

Plot 6-59: Radiated Emissions 12 GHz – 18 GHz Vertical Peak/Average

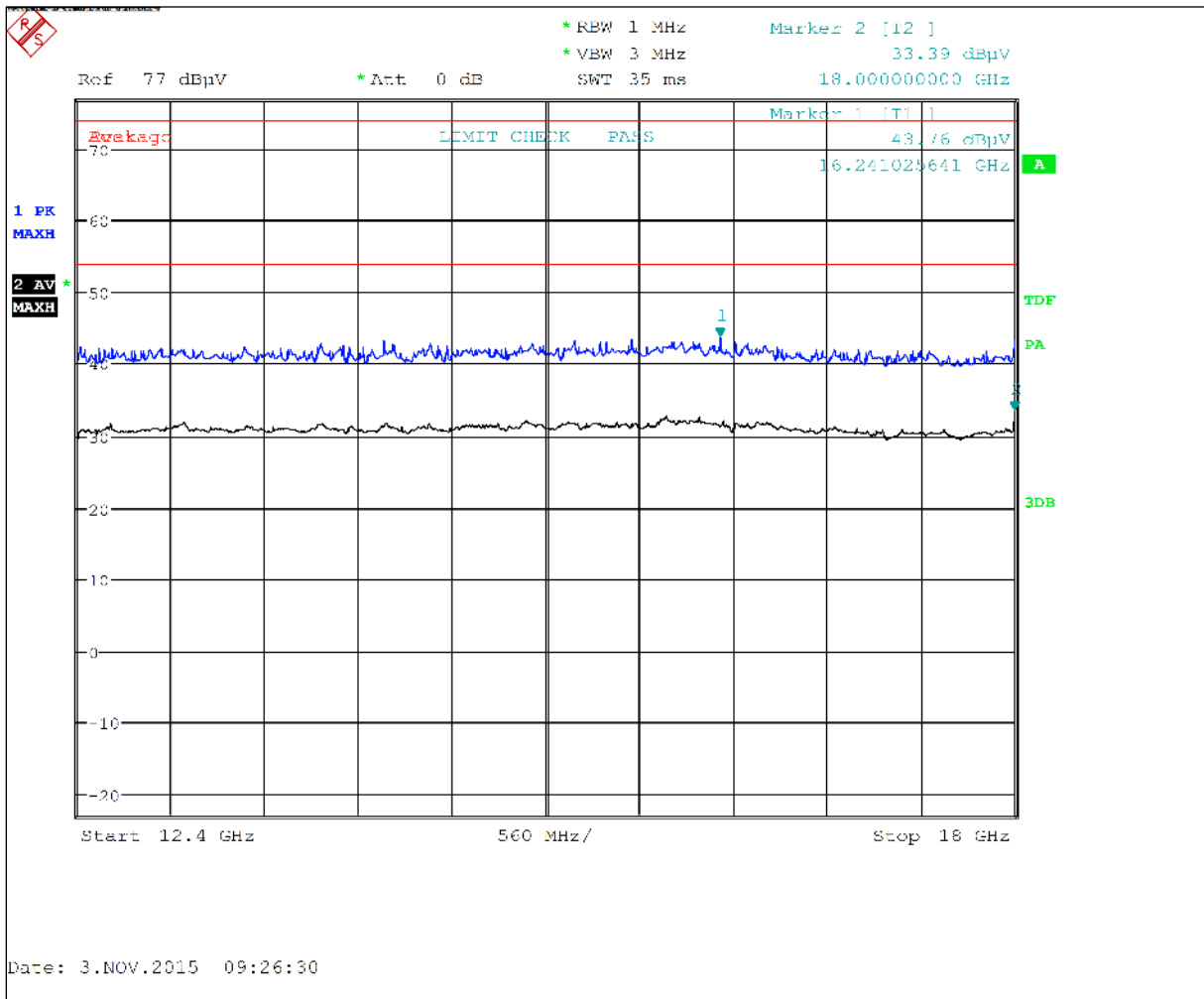

Plot 6-60: Radiated Emissions 18 GHz – 26 GHz Horizontal Peak/Average

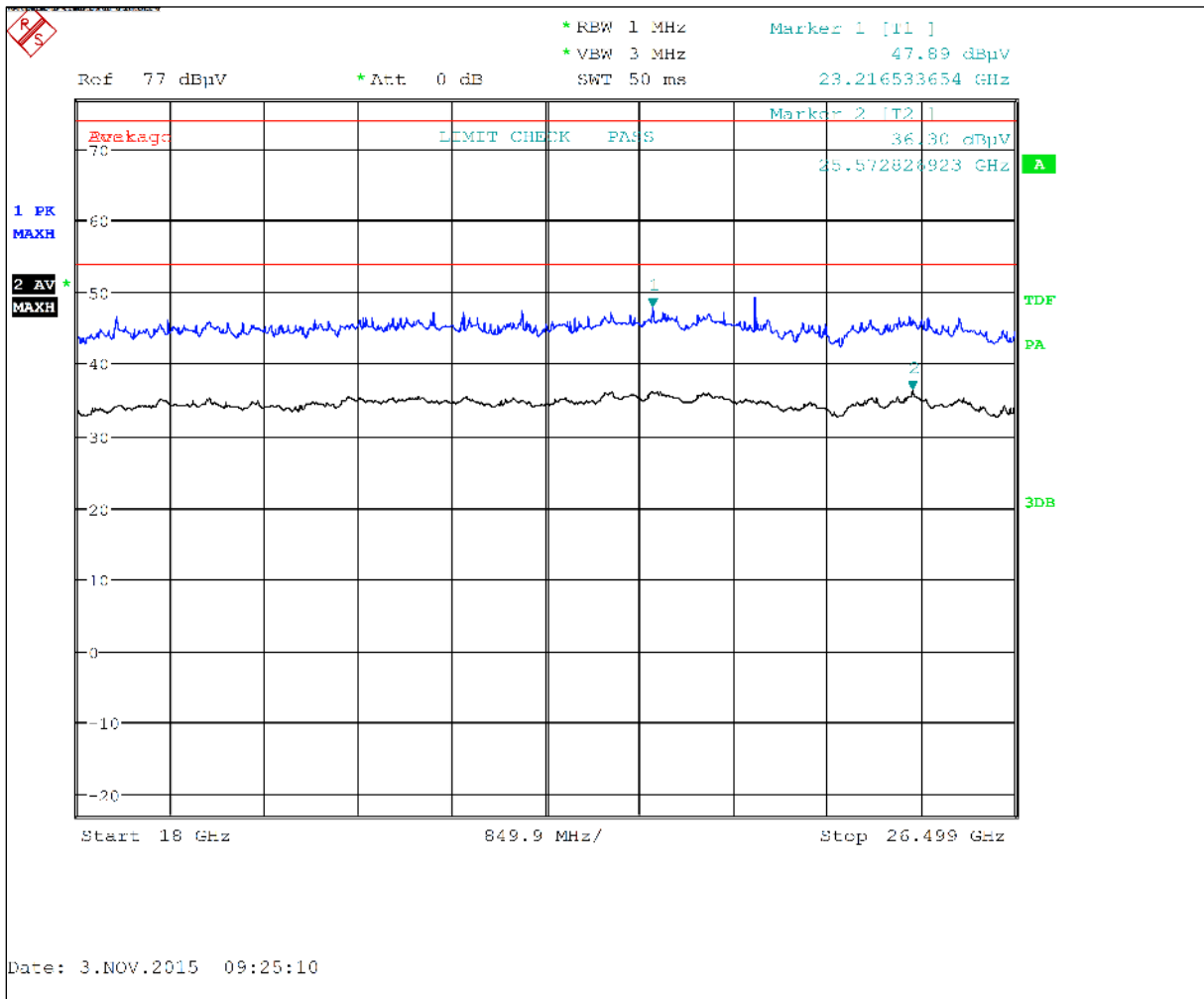

Plot 6-61: Radiated Emissions 18 GHz – 26 GHz Vertical Peak/Average

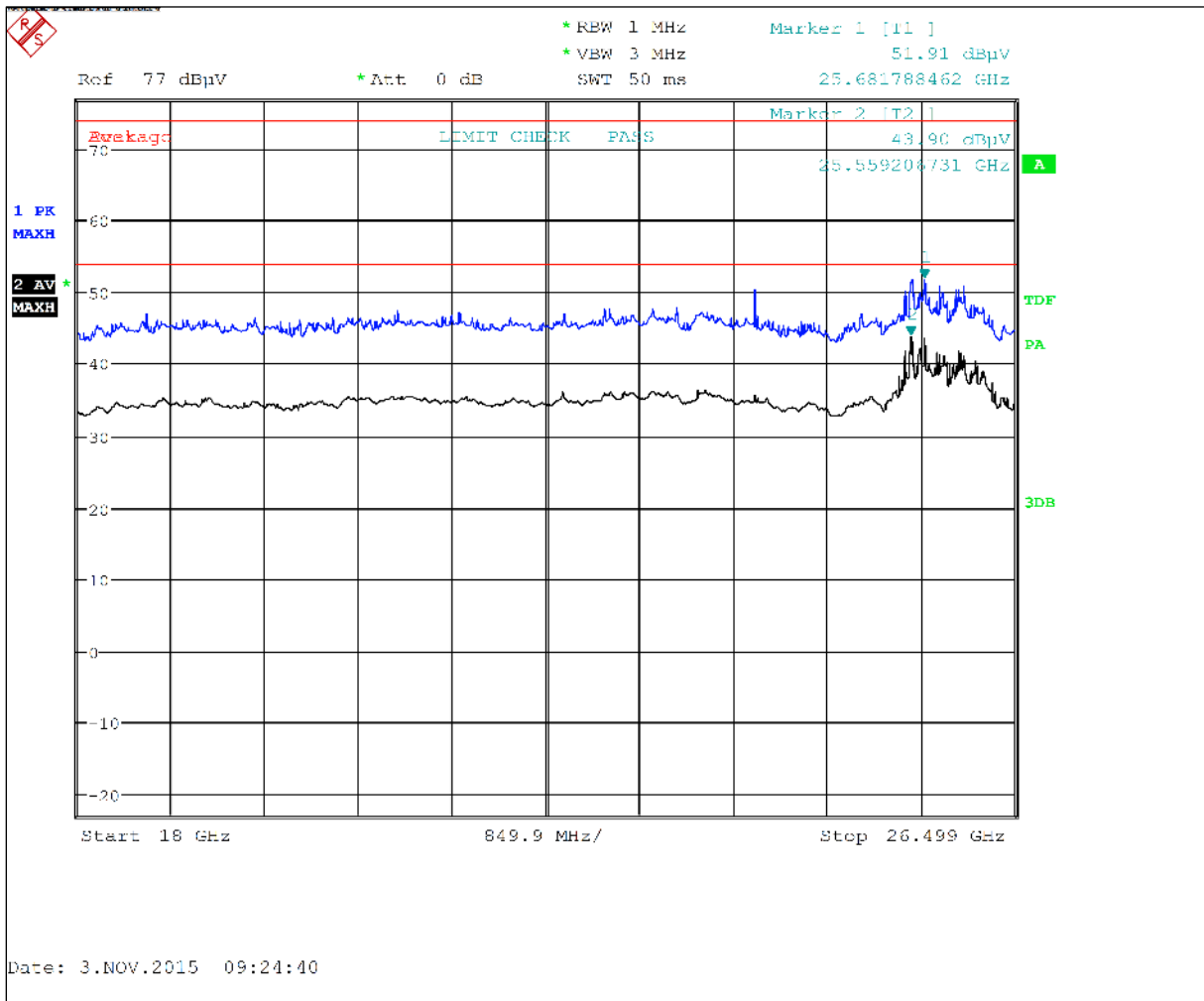

6.3.1.1 Radiated Emissions Carrier Test Data - TC#4 Steel Container

Plot 6-62: Radiated Emissions of Carrier - TC #4 Steel Container

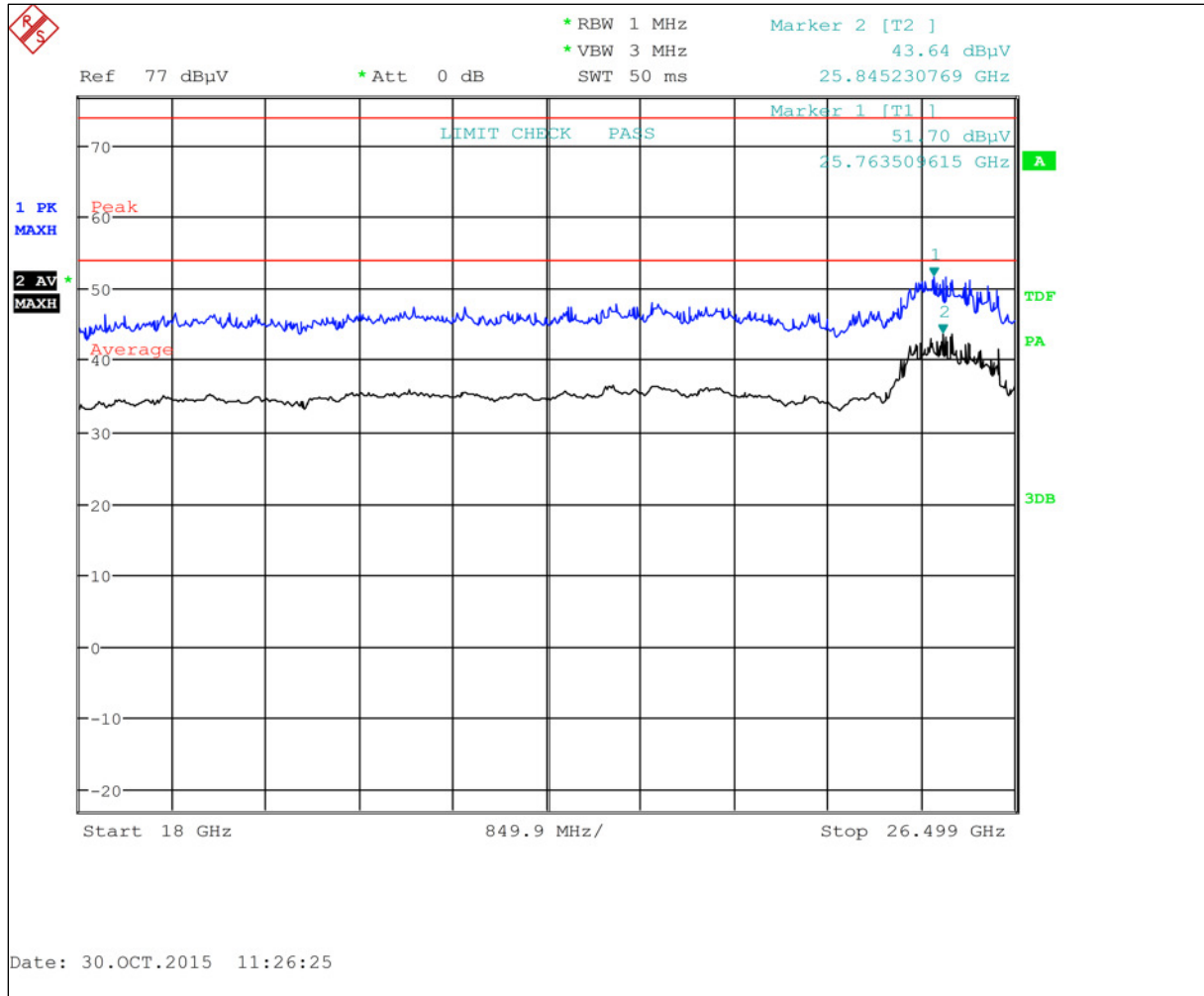
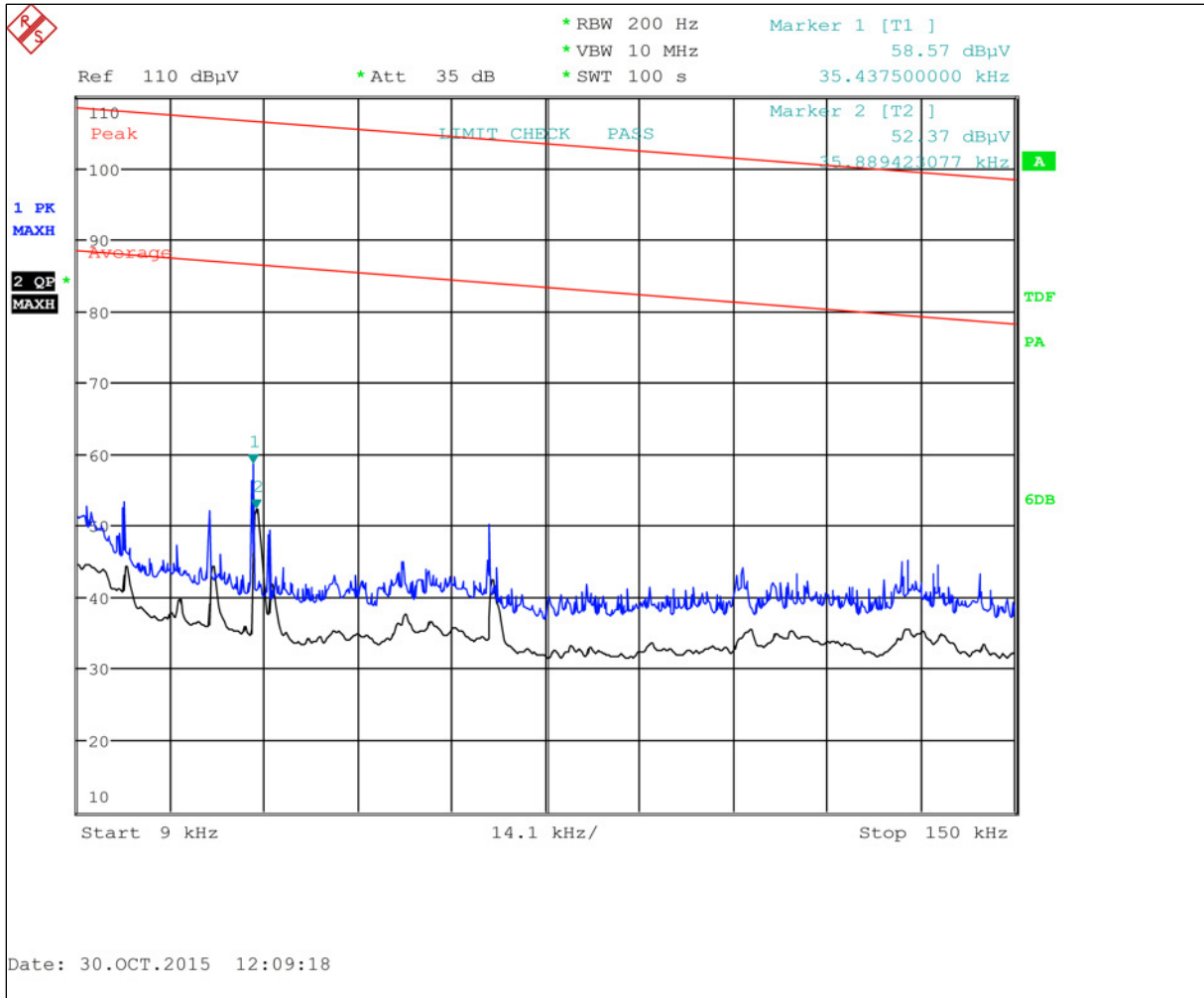

Table 6-4: Radiated Emissions of Carrier – TC #4 Steel Container

Frequency (GHz)	Detector	Test Antenna Pol	Corrected Spectrum Analyzer Level (dBuV/m)	FCC Limit (dBuV)	Margin (dB)	Corrected Spectrum Analyzer Level (dBm/MHz)	IC Limit (dBm/MHz)	Margin (dBm)
25.8452	Peak	V	51.7	74.0	-22.3	NA		
25.7635	Average	V	43.6	54.0	-10.4	-51.6	-41.3	10.3

6.3.1.2 Radiated Emissions Below 1 GHz Test Data – TC#4 Steel Container

Plot 6-63: Radiated Emissions Transmit – 9 kHz – 150 kHz Horizontal Peak/Average



Plot 6-64: Radiated Emissions Transmit – 9 kHz – 150 kHz Vertical Peak/Average

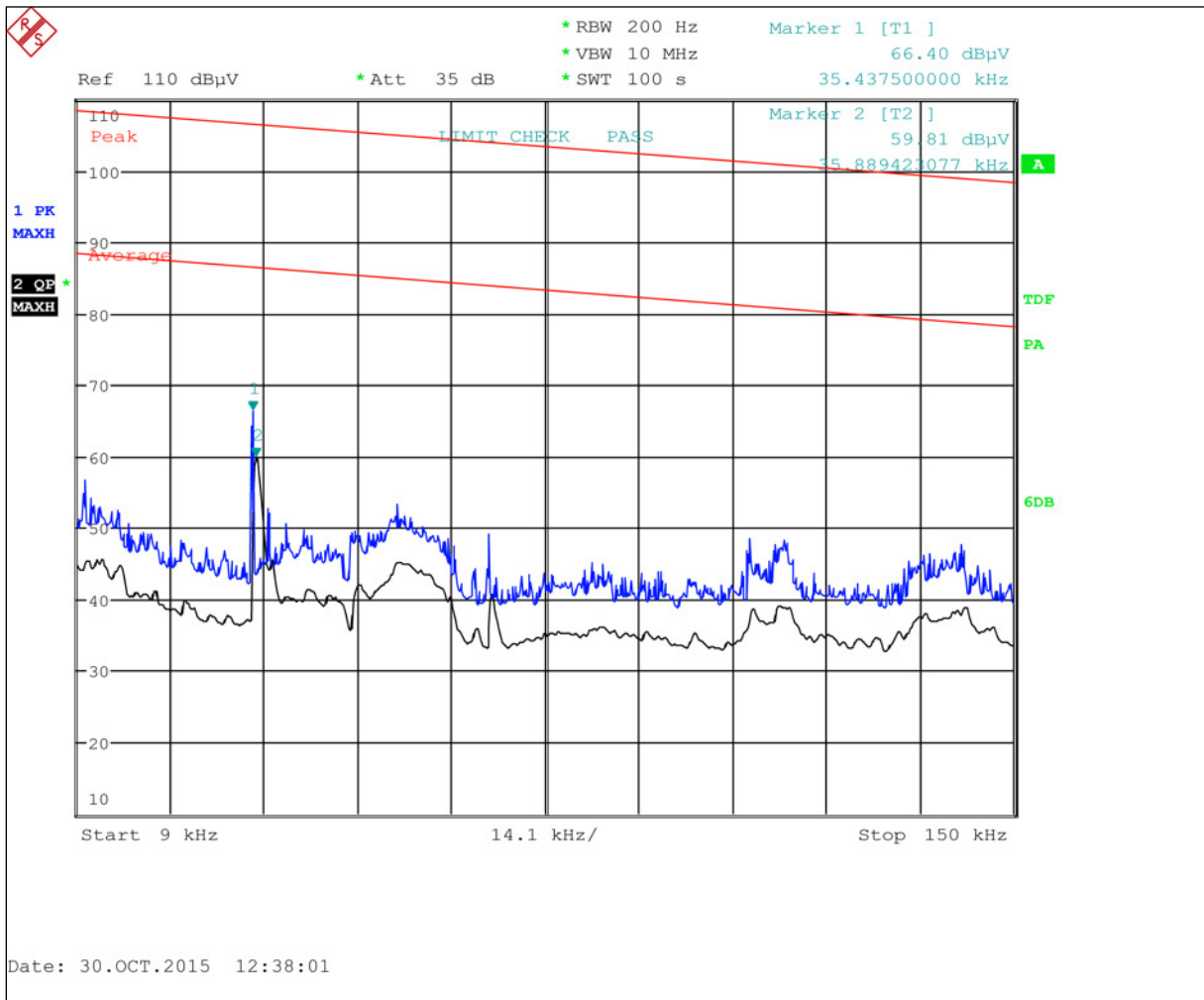

Plot 6-65: Radiated Emissions Transmit – 150 kHz – 2 MHz Horizontal Peak/Average

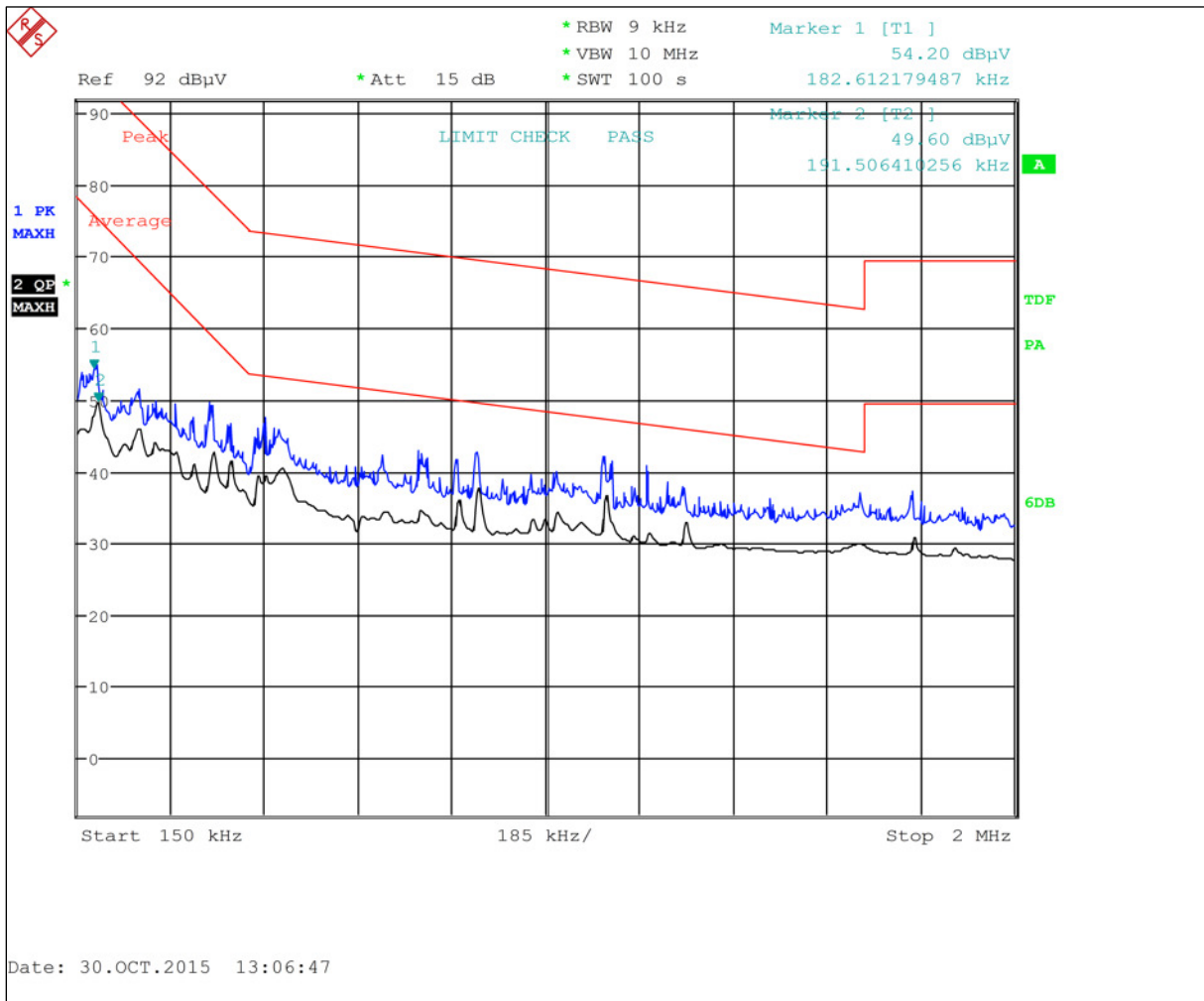

Plot 6-66: Radiated Emissions Transmit – 150 kHz – 2 MHz Vertical Peak/Average

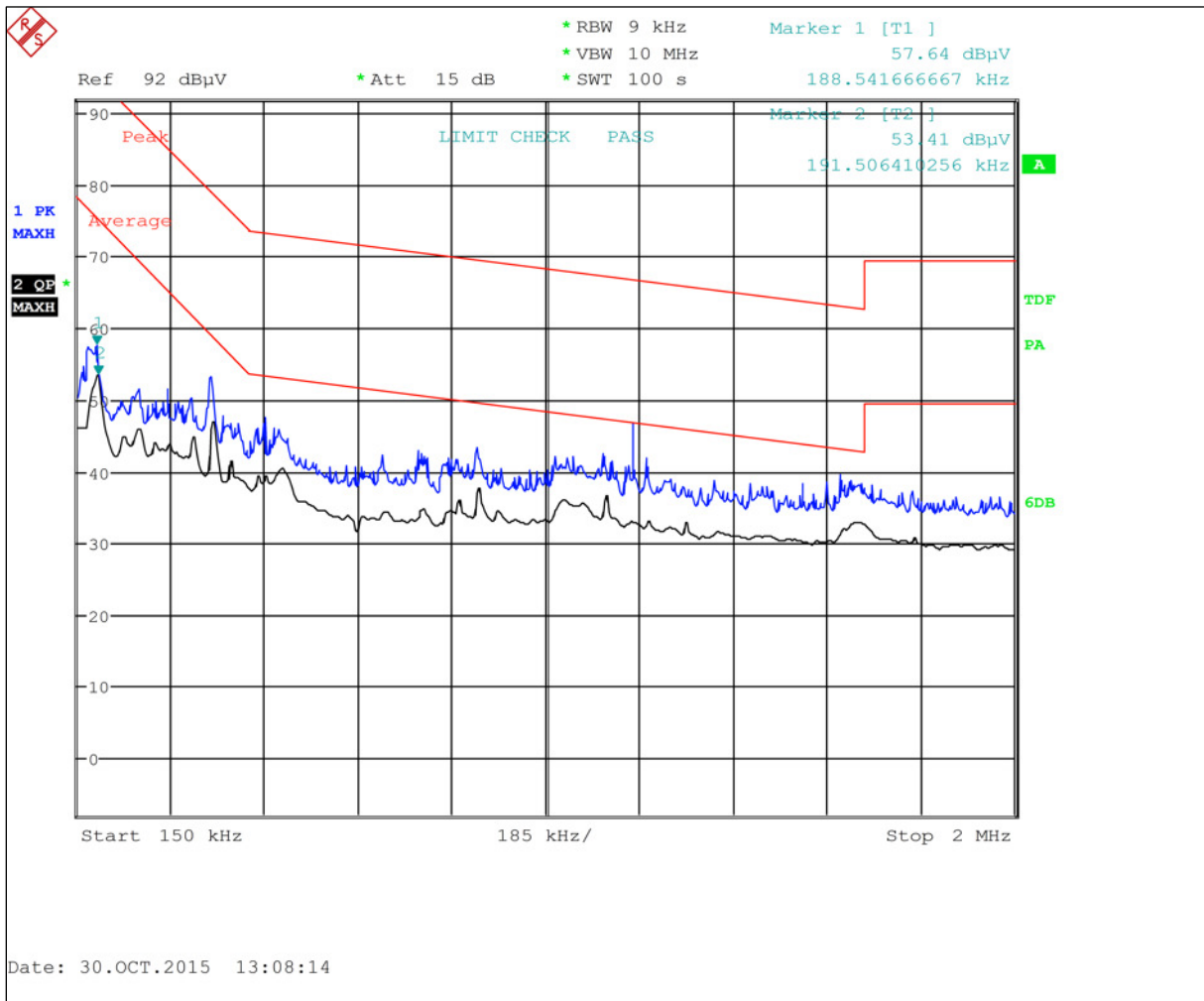

Plot 6-67: Radiated Emissions Transmit – 2 MHz – 30 MHz Horizontal Peak/Average

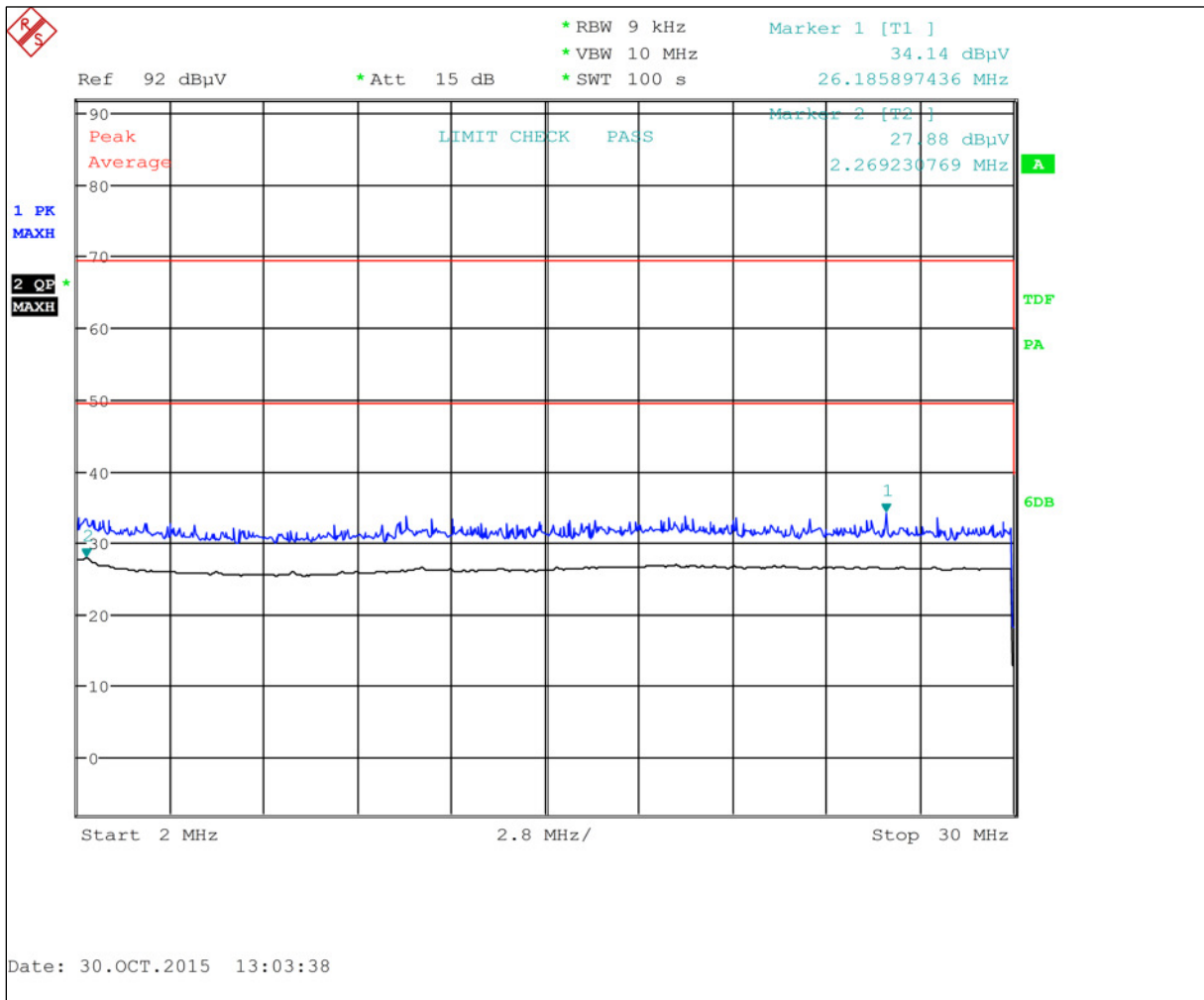

Plot 6-68: Radiated Emissions Transmit – 2 MHz – 30 MHz Vertical Peak/Average

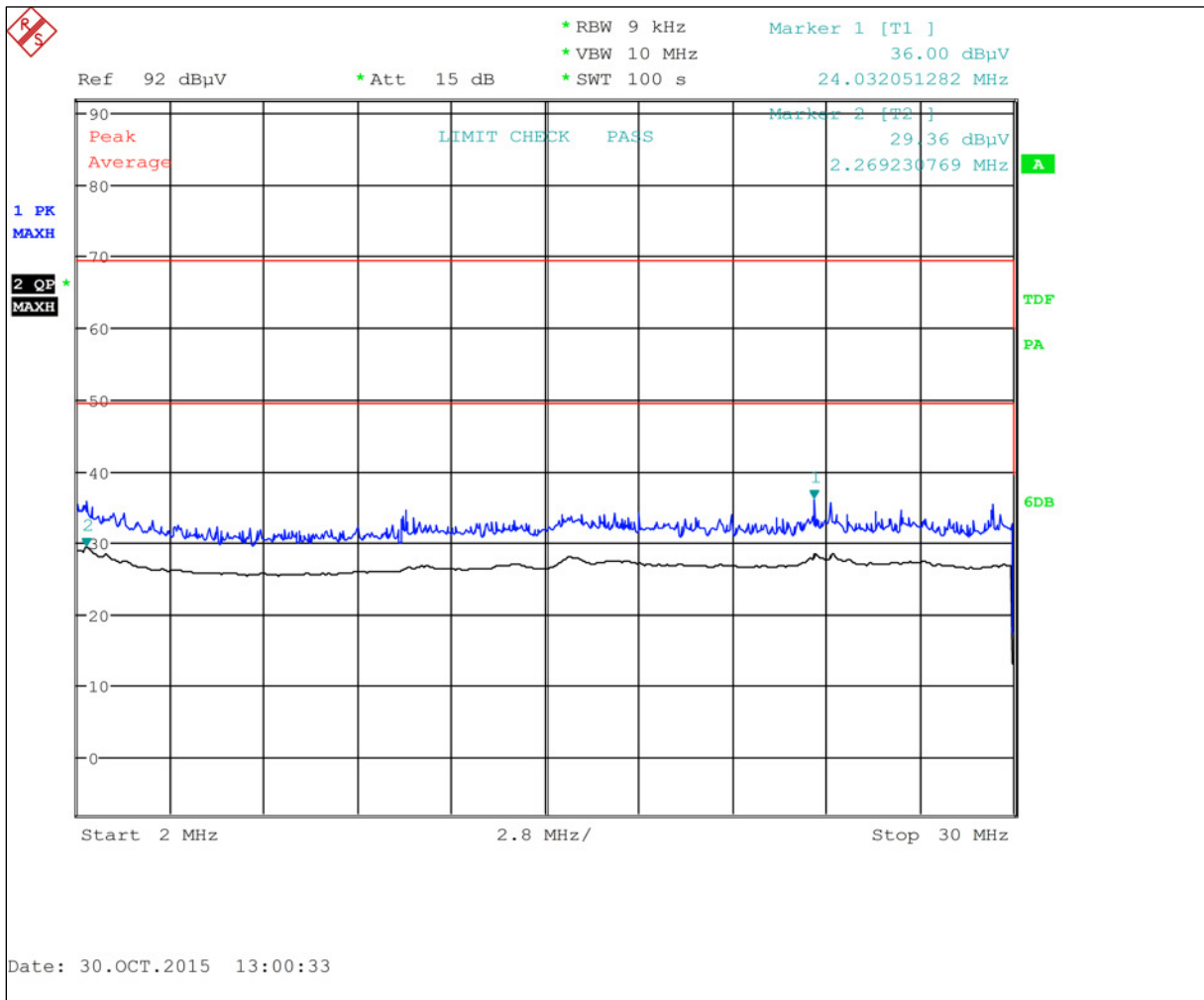

Plot 6-69: Radiated Emissions Transmit – 30 MHz – 1 GHz Horizontal Peak/Average

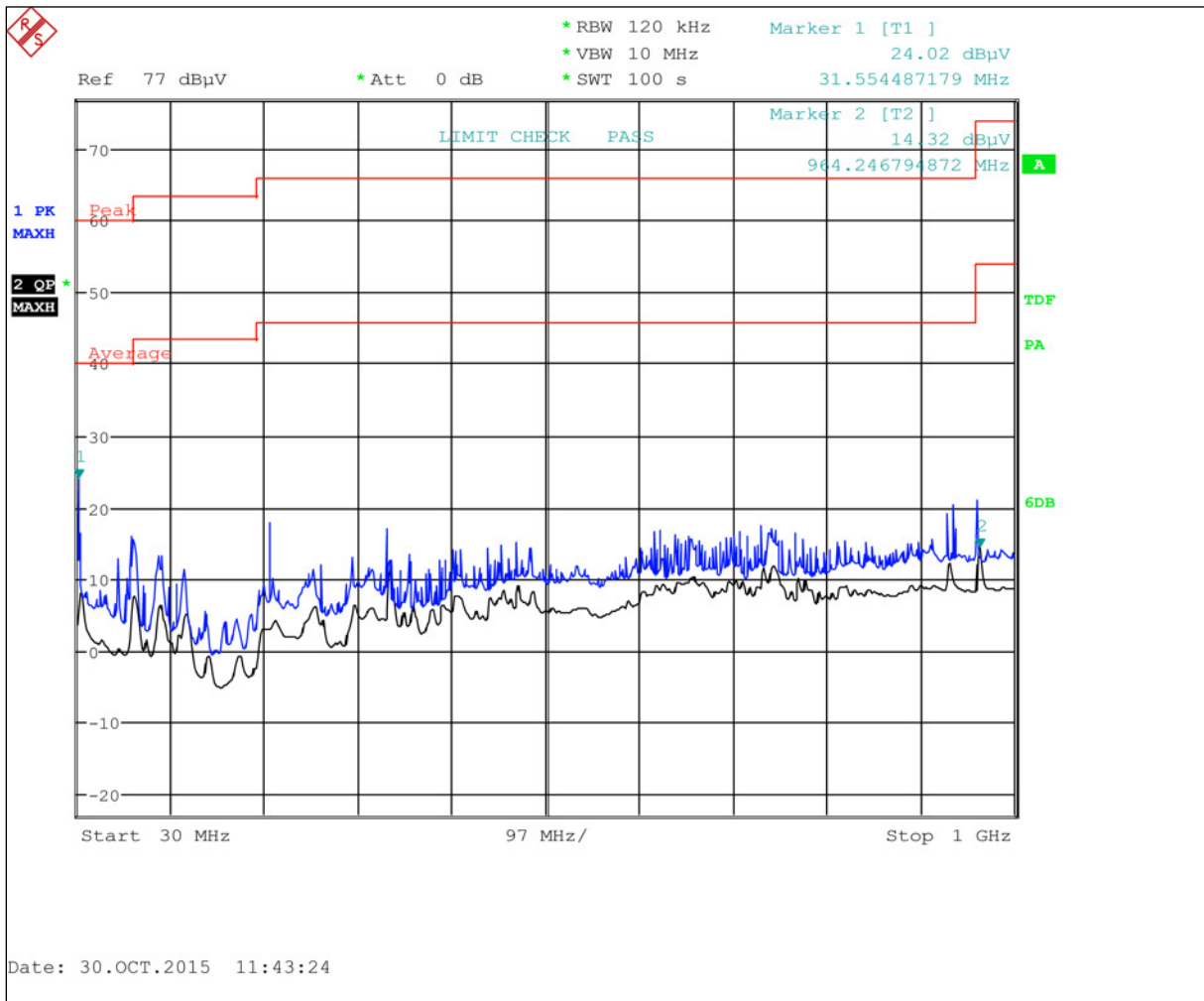

Plot 6-70: Radiated Emissions Transmit – 30 MHz – 1 GHz Vertical Peak/Average

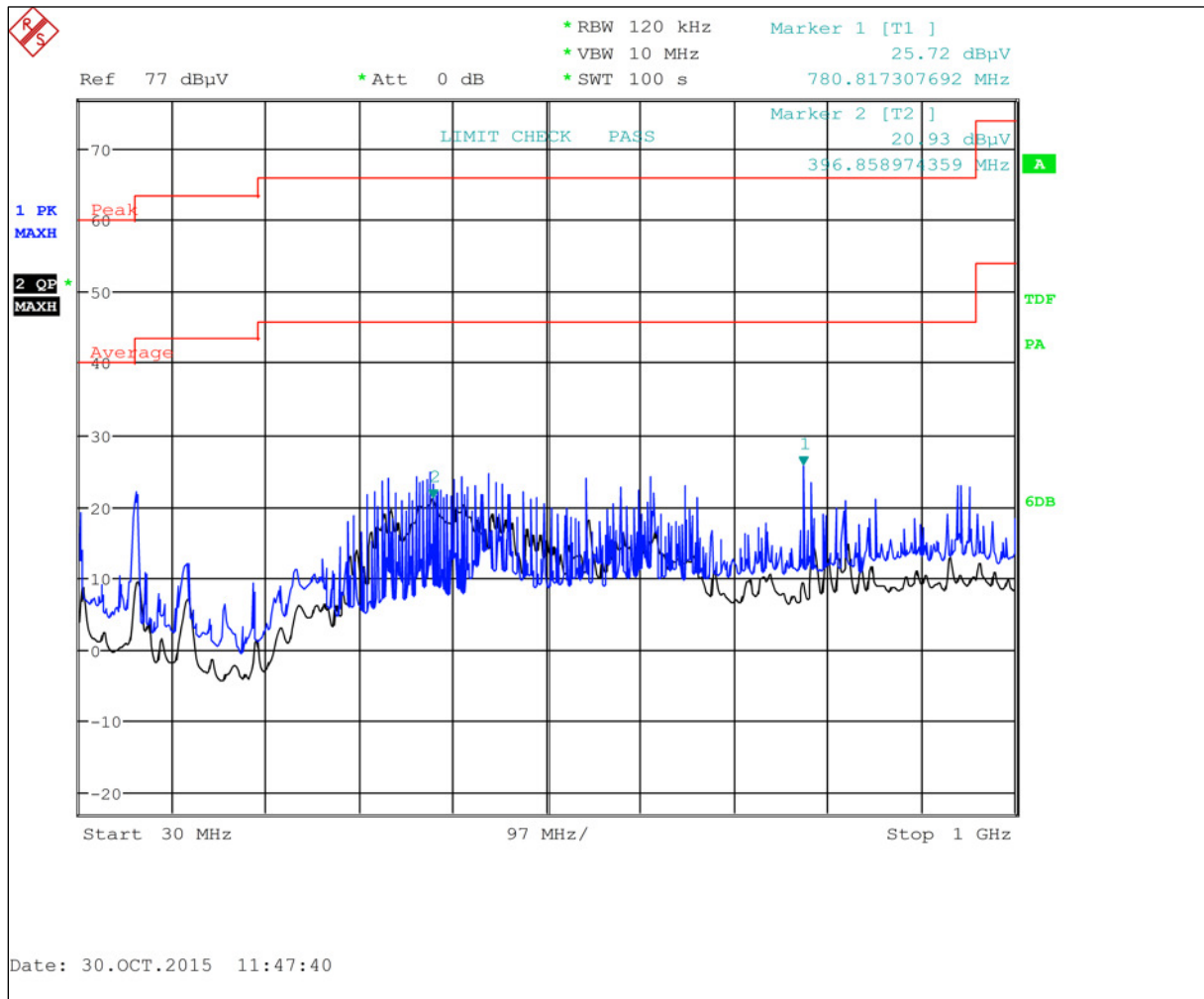

Note: Unwanted emissions were investigated as a digital device (other than harmonics) as required by 15.33(a)(3).

6.3.1.3 Radiated Emissions 1 GHz – 26 GHz Test Data – TC#4 Steel Container

Plot 6-71: Radiated Emissions 1 GHz – 2 GHz Horizontal Peak/Average

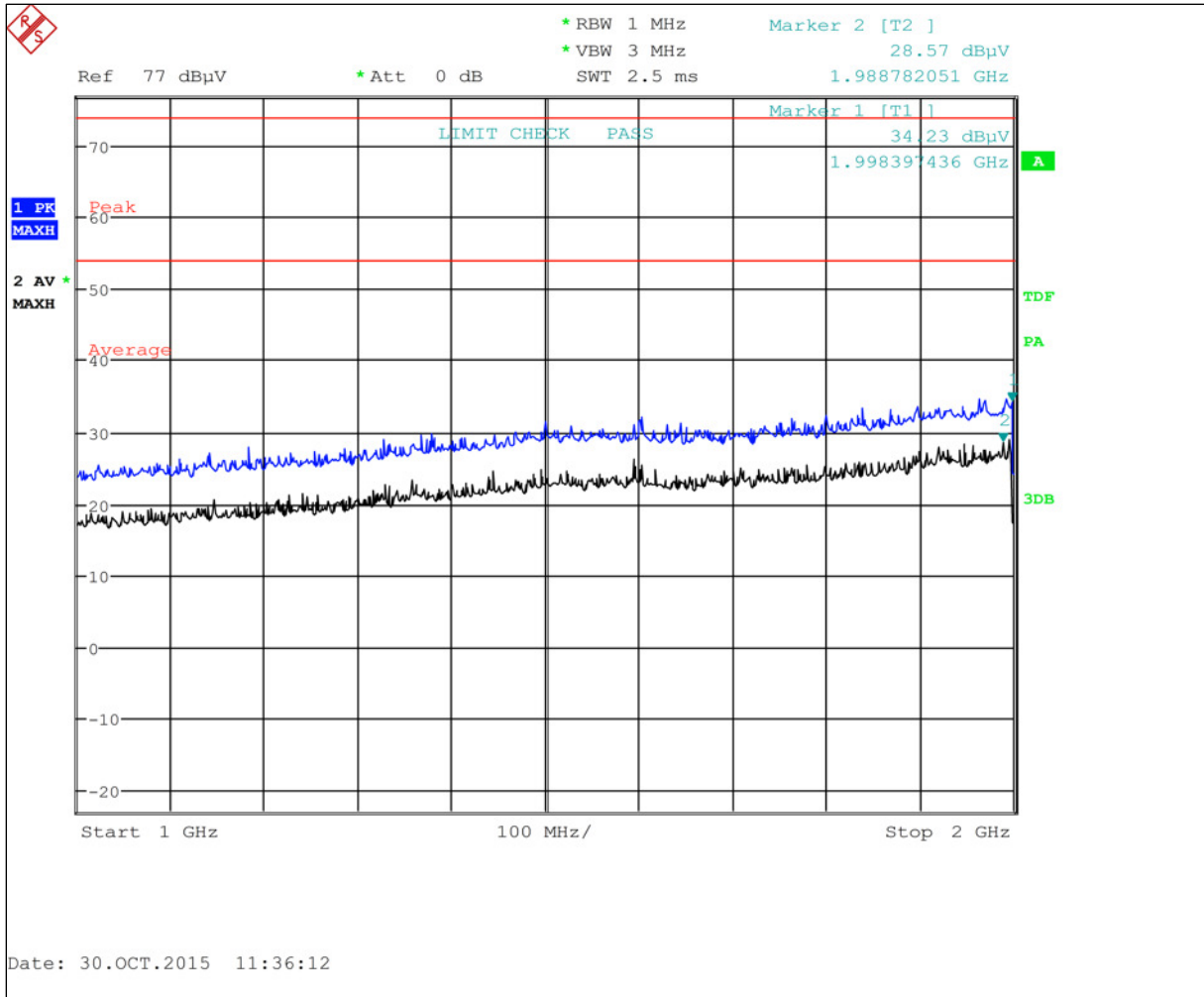

Plot 6-72: Radiated Emissions 1 GHz – 2 GHz Vertical Peak/Average

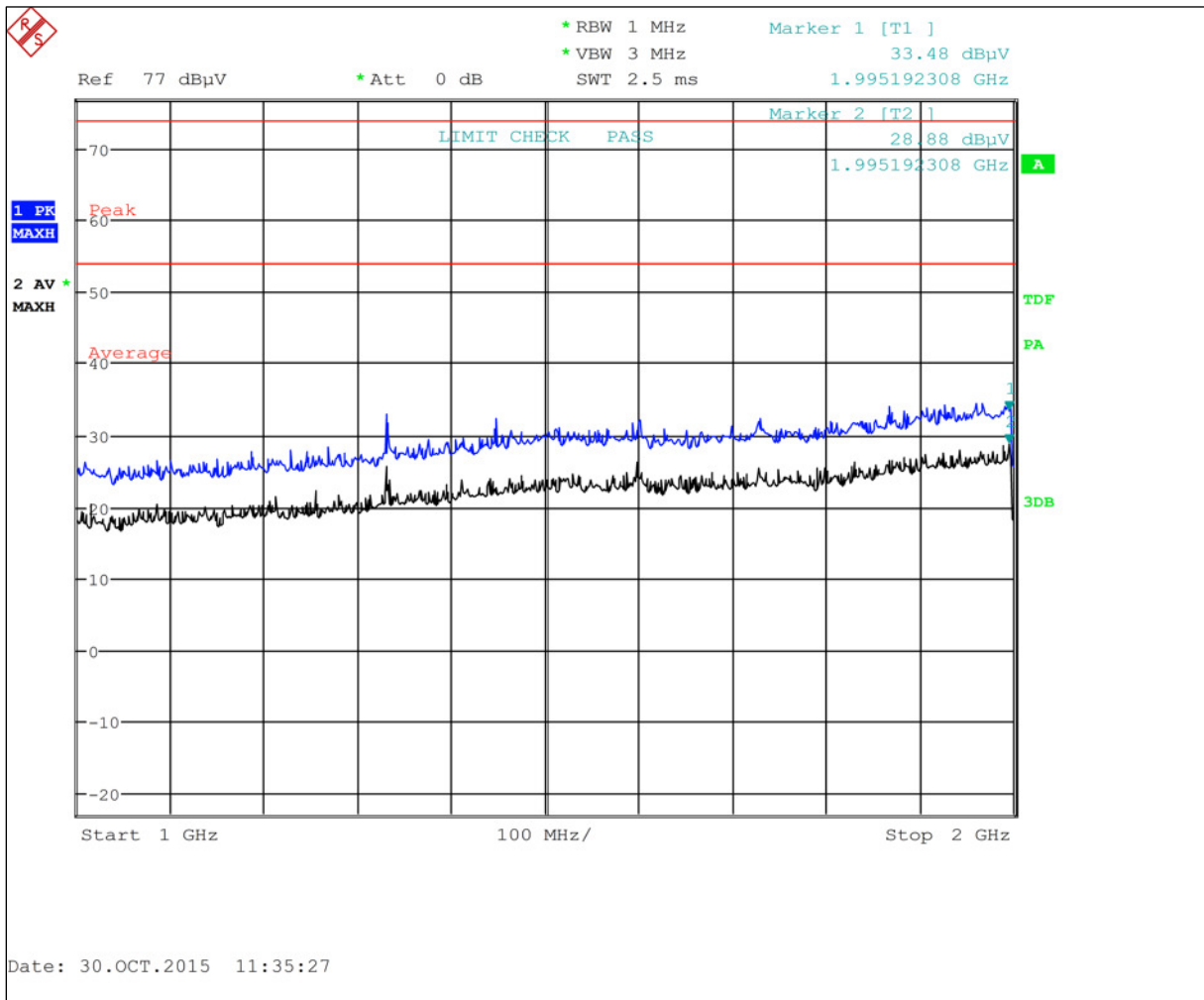

Plot 6-73: Radiated Emissions 2 GHz – 4 GHz Horizontal Peak/Average

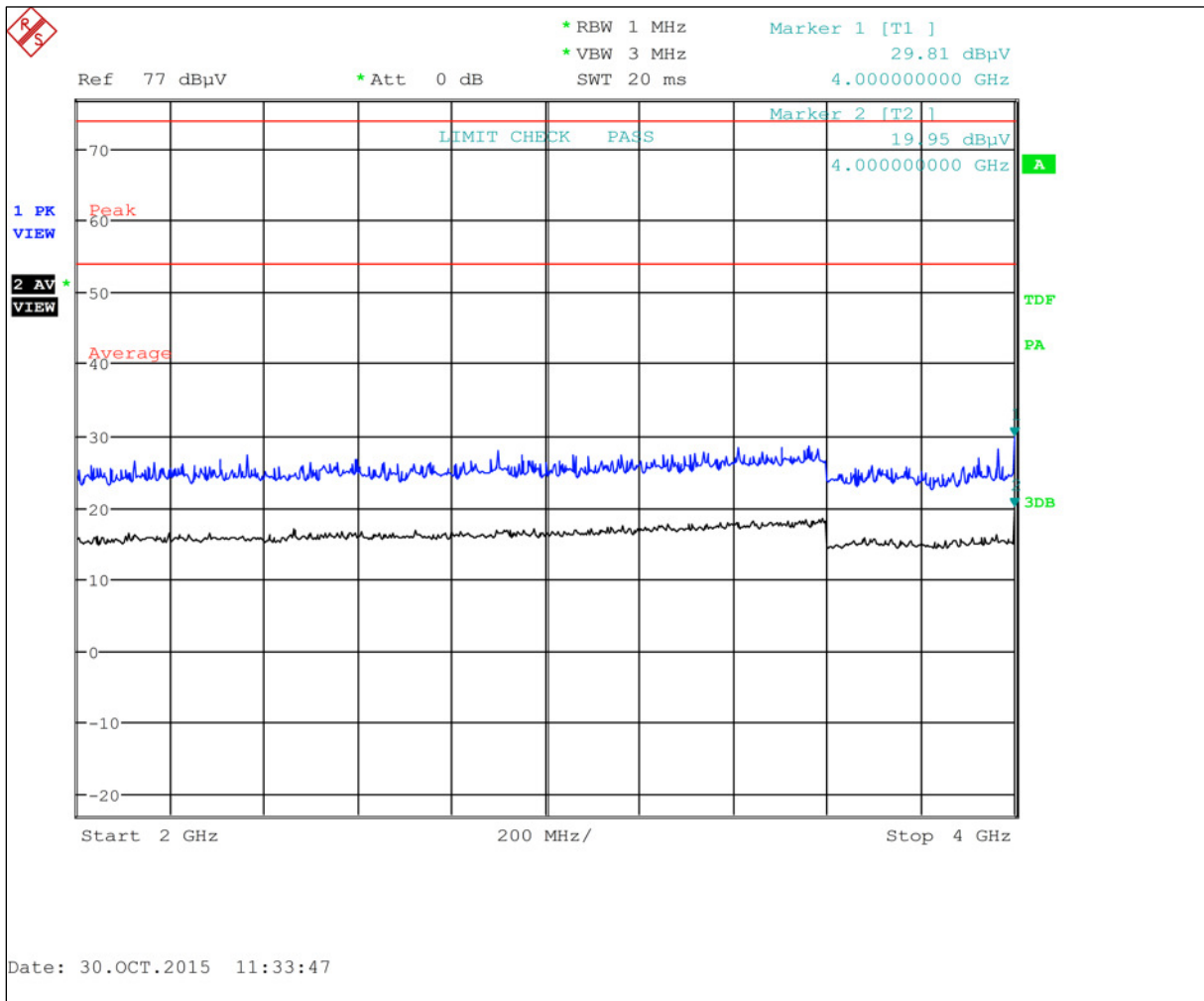

Plot 6-74: Radiated Emissions 2 GHz – 4 GHz Vertical Peak/Average

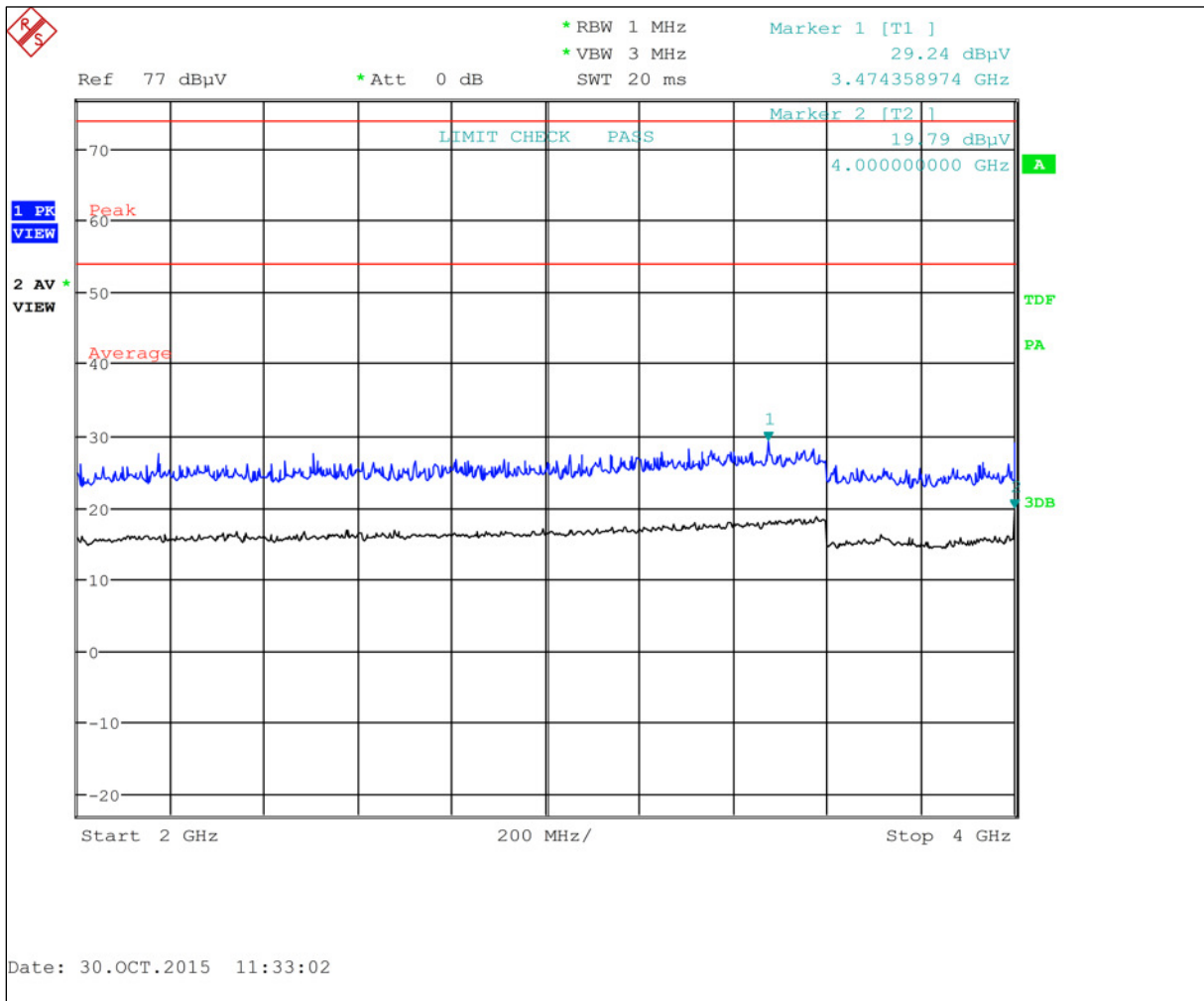

Plot 6-75: Radiated Emissions 4 GHz – 8 GHz Horizontal Peak/Average

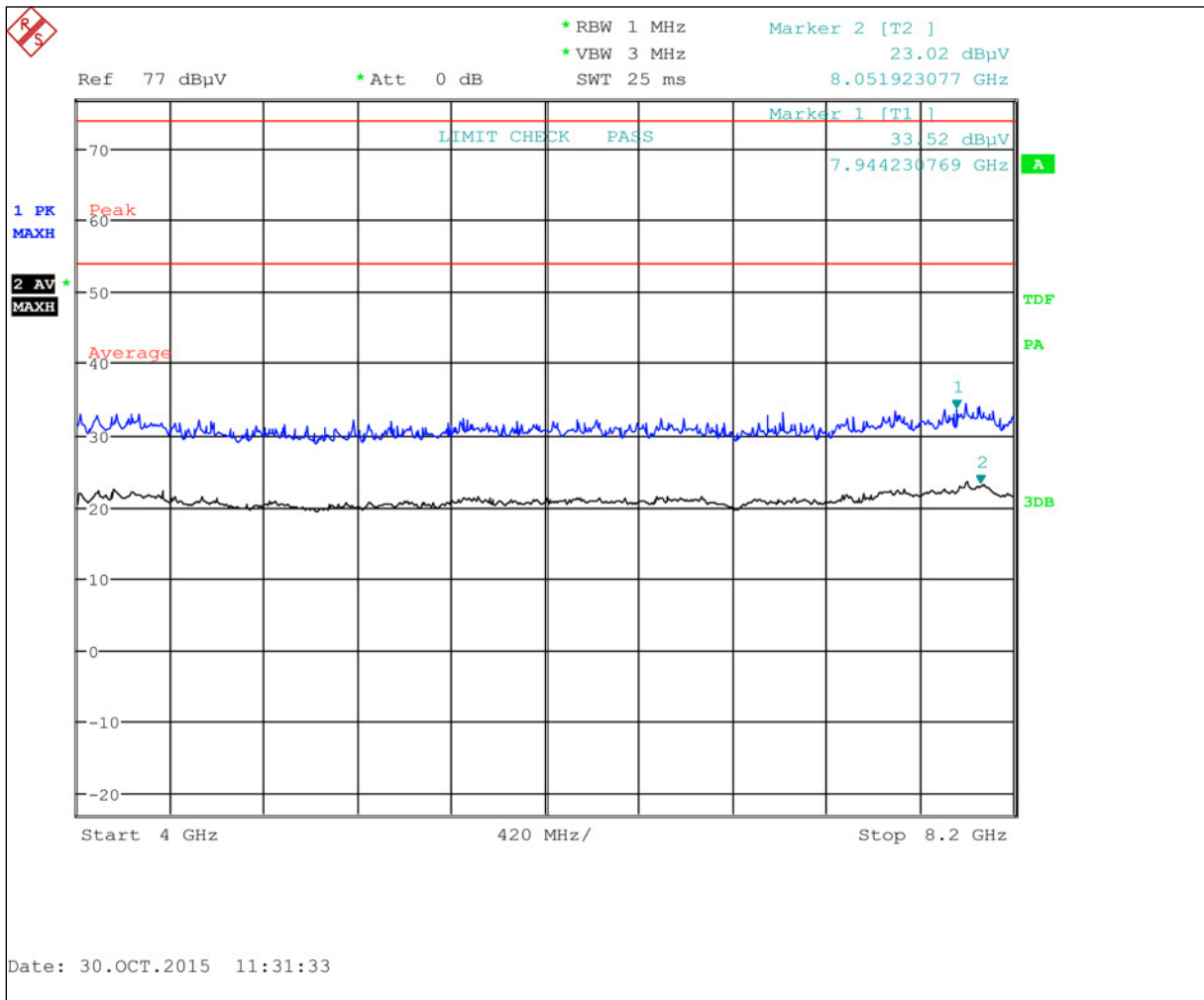

Plot 6-76: Radiated Emissions 4 GHz – 8 GHz Vertical Peak/Average

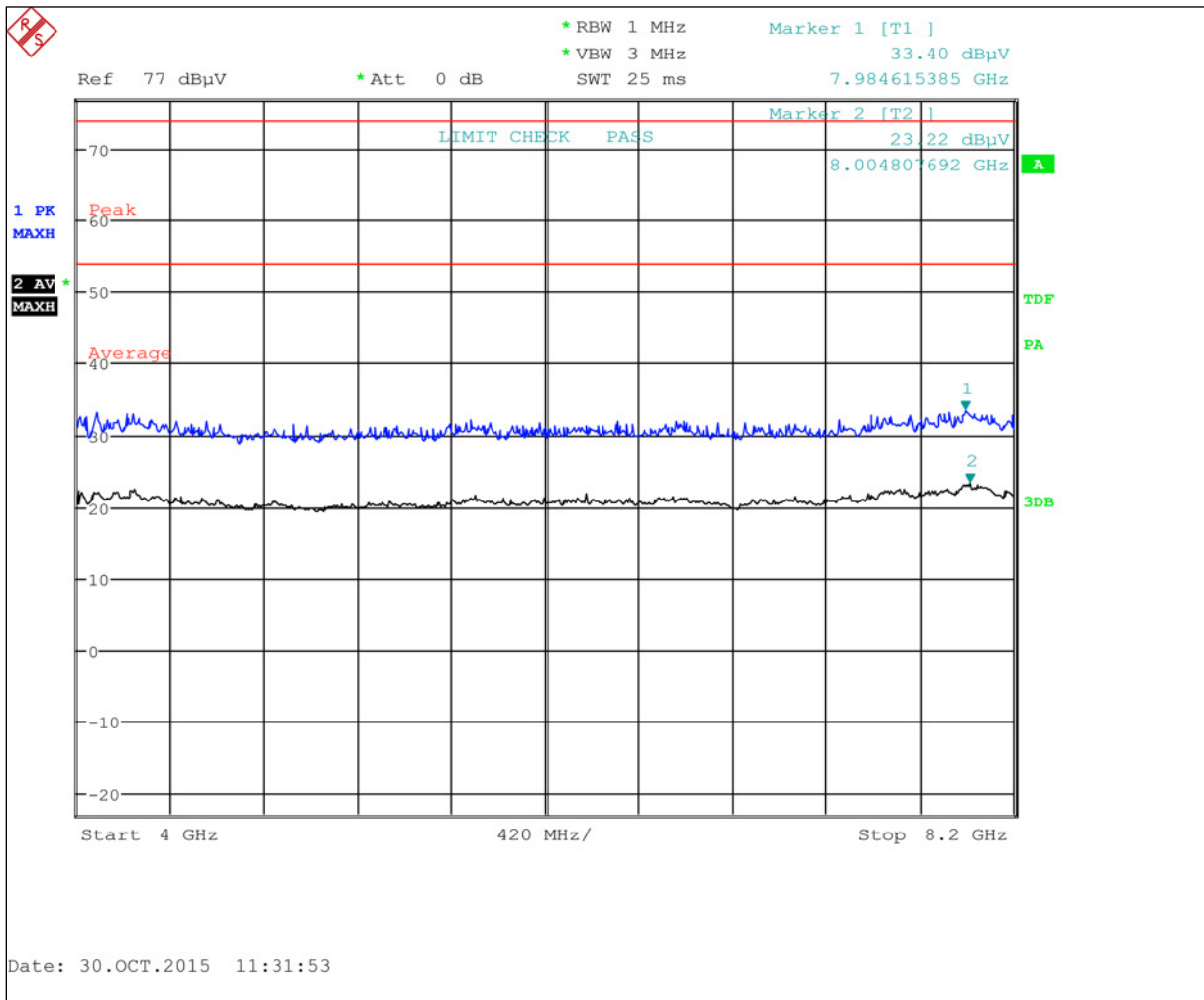

Plot 6-77: Radiated Emissions 8 GHz – 12 GHz Horizontal Peak/Average

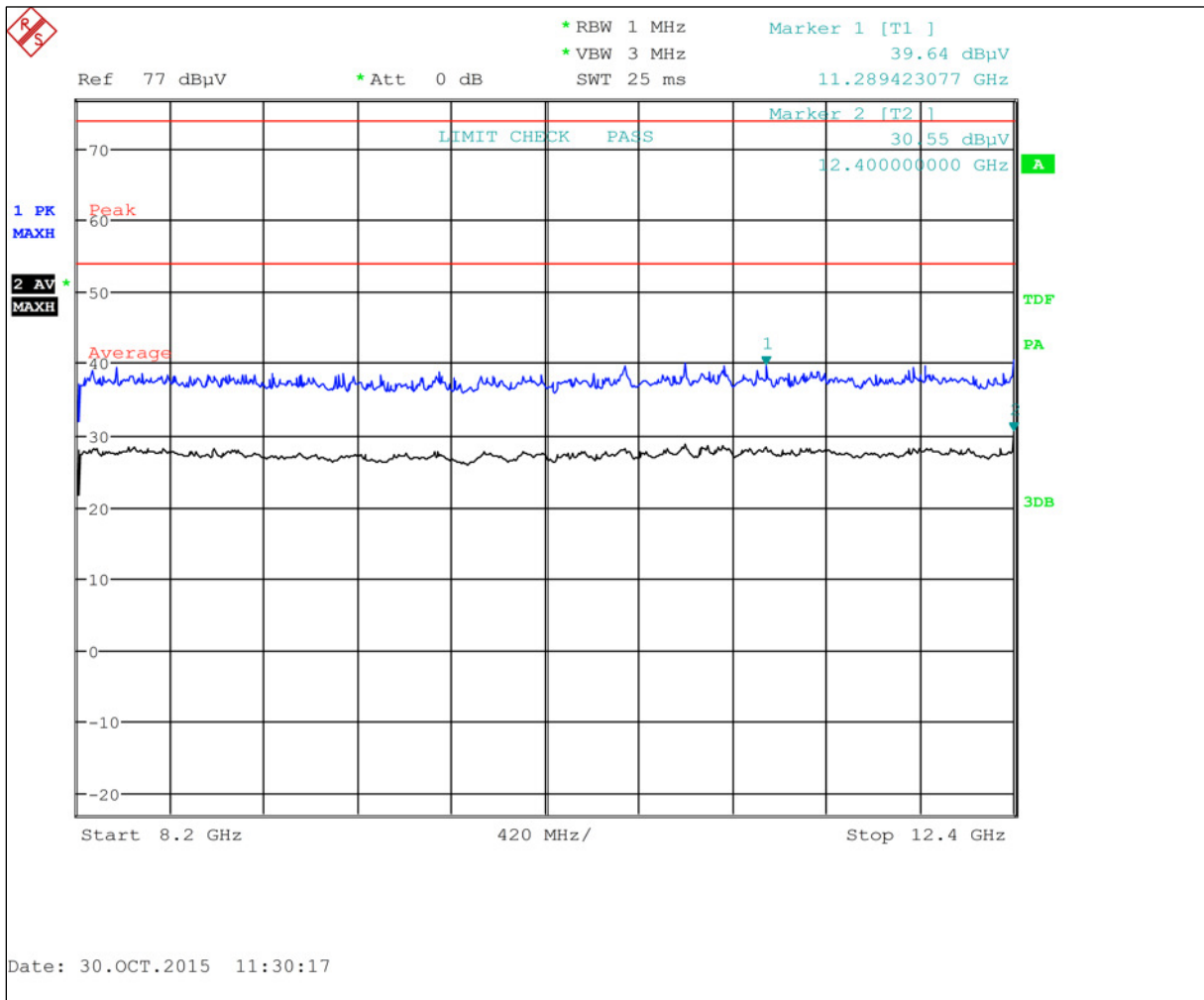

Plot 6-78: Radiated Emissions 8 GHz – 12 GHz Vertical Peak/Average

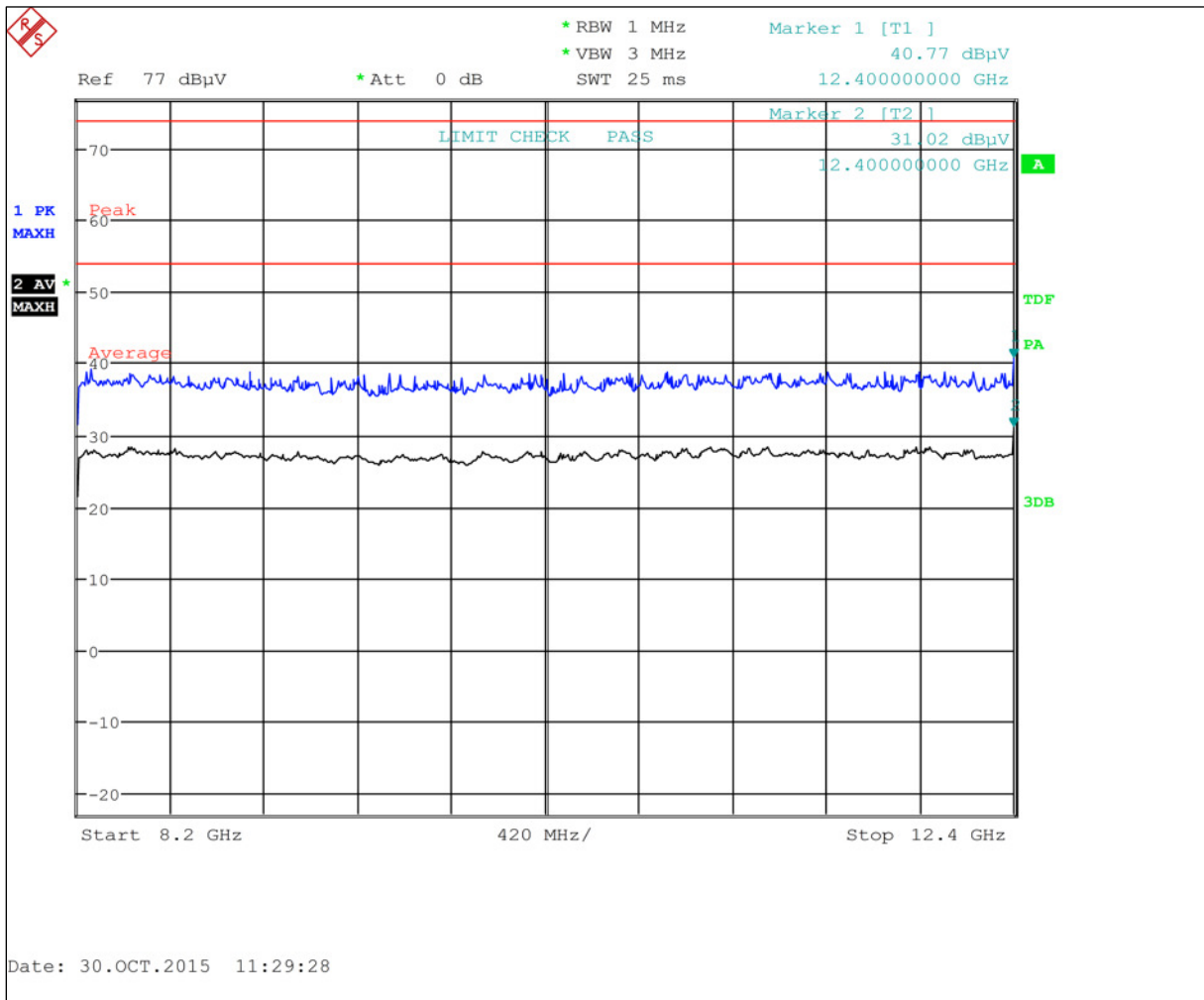

Plot 6-79: Radiated Emissions 12 GHz – 18 GHz Horizontal Peak/Average

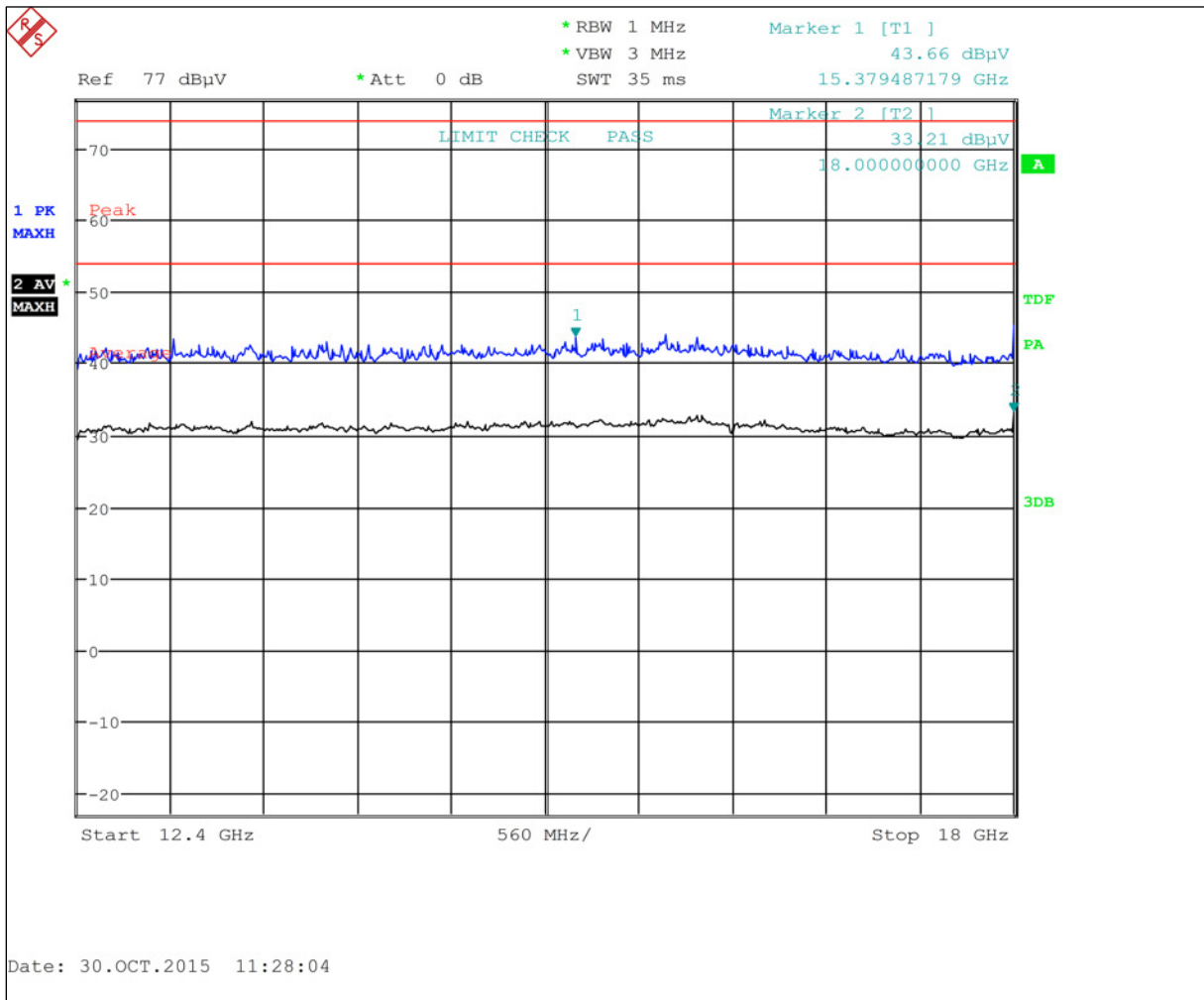

Plot 6-80: Radiated Emissions 12 GHz – 18 GHz Vertical Peak/Average

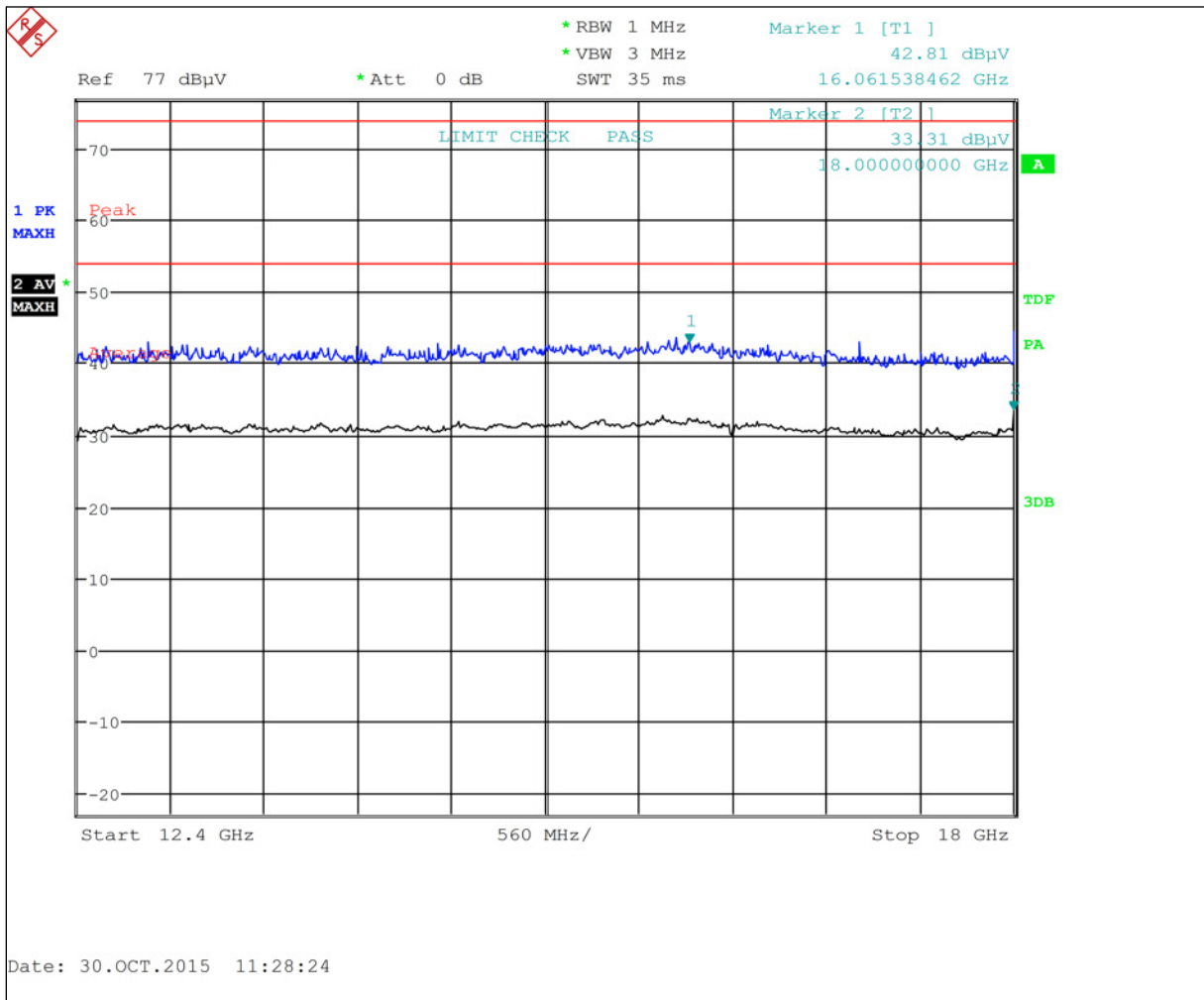

Plot 6-81: Radiated Emissions 18 GHz – 26 GHz Horizontal Peak/Average

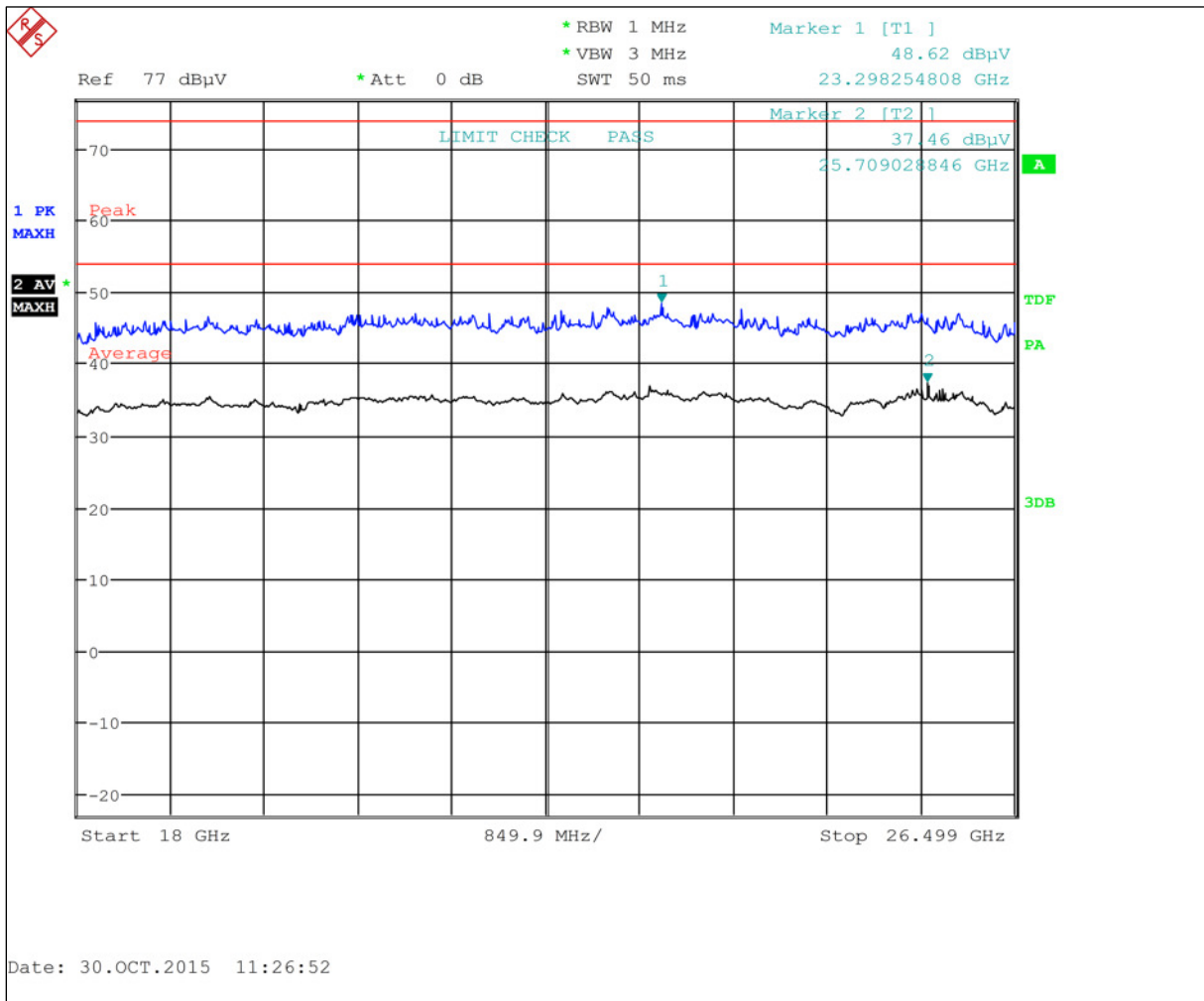

Plot 6-82: Radiated Emissions 18 GHz – 26 GHz Vertical Peak/Average

