

EMC TEST REPORT

Report No.: TS13060025-EME**Model No.:** TTD-VMi110**Issued Date:** Jul. 04, 2013**Applicant:** Tranwo Technology Corp.
No. 236, Sec. 3, Huanbei Rd., Jubei City, Hsinchu
County 30265, Taiwan**Test Method / Standard:** CFR 47 FCC Part 15.247 & ANSI C63.4 2003**Test By:** Intertek Testing Services Taiwan Ltd.
No. 11, Lane 275, Ko-Nan 1 Street, Chia-Tung Li,
Shiang-Shan District, Hsinchu City, Taiwan

It may be duplicated completely for legal use with the allowance of the applicant. It shall not be reproduced except in full, without the written approval of Intertek Laboratory. The test result(s) in this report only applies to the tested sample(s).

**The test report was prepared by:***Jill Chen*

Jill Chen / Assistant

These measurements were taken by:*Hugo Yeh*

Hugo Yeh / Engineer

The test report was reviewed by:**Name** Jimmy Yang**Title** Engineer



Table of Contents

1. Summary of Test Data	3
2. General Information	4
3. Maximum 6 dB Bandwidth	7
4. 99 % Occupied Bandwidth.....	15
5. Maximum Output Power	23
6. Power Spectral Density	25
7. RF Antenna Conducted Spurious	33
8. Radiated Spurious Emission.....	52
9. Emission on Band Edge	62
10. AC power line conducted emission.....	72
Appendix: Test Equipment List	75

1. Summary of Test Data

Test/Requirement Description	Applicable Rule	Result
Minimum 6 dB Bandwidth	15.247(a)(2)	Pass
Maximum Output Power	15.247(b)	Pass
Power Spectral Density	15.247(e)	Pass
RF Antenna Conducted Spurious	15.247(d)	Pass
Radiated Spurious Emission	15.247(d), 15.205, 15.209	Pass
Emission on the Band Edge	15.247(d)	Pass
AC Power Line Conducted Emission	15.207	Pass

2. General Information

Identification of the EUT

Product:	Easy iCam
Model No.:	TTD-VMi110
FCC ID.:	O6LTTD-VMI110
Frequency Range:	1. 2412 MHz ~ 2462 MHz for 802.11b, 802.11g, 802.11n HT20 2. 2422 MHz ~ 2452 MHz for 802.11n HT40
Channel Number:	1. 11 channels for 2412 MHz ~ 2462 MHz 2. 7 channels for 2422 MHz ~ 2452 MHz
Frequency of Each Channel:	1. 2412+5 k, k=0~10 for 802.11b, 802.11g, 802.11n HT20 2. 2422+5 k, k=0~6 for 802.11n HT40
Type of Modulation:	DSSS, OFDM
Rated Power:	DC 6 V from adapter
Power Cord:	N/A
Data Cable:	N/A
Sample Received:	Jan. 02, 2013
Test Date(s):	Jan. 02, 2013~Jun. 29, 2013
Note 1:	This report is for the exclusive use of Intertek's Client and is provided pursuant to the agreement between Intertek and its Client. Intertek's responsibility and liability are limited to the terms and conditions of the agreement. Intertek assumes no liability to any party, other than to the Client in accordance with the agreement, for any loss, expense or damage occasioned by the use of this report. Only the Client is authorized to permit copying or distribution of this report and then only in its entirety. Any use of the Intertek name or one of its marks for the sale or advertisement of the tested material, product or service must first be approved in writing by Intertek. The observations and test results in this report are relevant only to the sample tested. This report by itself does not imply that the material, product, or service is or has ever been under an Intertek certification program.
Note 2:	When determining the test conclusion, the Measurement Uncertainty of test has been considered.

Description of EUT

The EUT is Easy iCam, and was defined as information technology equipment.

For more detail features, please refer to User's manual as file name "Installation guide.pdf"

Adapter information

The EUT will be supplied with a power supply from below list:

No.	Brand	Model no.	Specification
Adapter	Salom Electric(Xiamen) Co.,Ltd.	SSW-2256US	I/P: 100-240VAC, 50-60Hz, 0.2A O/P: 6.0VDC, 800mA

Antenna description

The EUT uses a permanently connected antenna.

Antenna Gain : 1.5 dBi
Antenna Type : Dipole Antenna
Connector Type : Fixed Type

Peripherals equipment

Peripherals	Brand	Model No.	Serial No.	Data Cable
Notebook PC	DELL	Latitude D610	4YWZK1S	N/A

Operation mode

The EUT was supplied with DC 6 V from adapter (Test voltage: 120VAC / 60 Hz).
Tester used "Continue_Tx/Rx command" to control the EUT. The EUT was controlled to transmit continuously during the tests.

With individual verifying, the maximum output power was found out 1 Mbps data rate for 802.11b mode, 6 Mbps data rate for 802.11g mode, 6.5 Mbps data rate for 802.11n HT 20 mode and 13.5 Mbps data rate for 802.11n HT 40 mode.

The final tests were executed under these conditions recorded in this report individually.

Please refer the details below:

Chain 0: 802.11b channel 6	
Data rate (Mbps)	PK(dBm)
1	15.53
2	15.46
5.5	15.41
11	15.38

Chain 0: 802.11n HT20 channel 6	
Data rate (Mbps)	PK(dBm)
6.5	18.86
13	18.81
19.5	18.74
26	18.67
39	18.62
52	18.57
58.5	18.53
65	18.49

Chain 0: 802.11g channel 6	
Data rate (Mbps)	PK(dBm)
6	20.91
9	20.82
12	20.78
18	20.73
24	20.65
36	20.61
48	20.56
54	20.52

Chain 0: 802.11n HT40 channel 6	
Data rate (Mbps)	PK(dBm)
13.5	19.12
27	19.08
40.5	18.92
54	18.85
81	18.78
108	18.72
121.5	18.66
135	18.59

3. Maximum 6 dB Bandwidth

Name of Test	Maximum 6 dB Bandwidth
Base Standard	FCC 15.247 (a)(2)

Test Result: Complies
Measurement Data: See Table & plots below
Test Date: Jun. 29, 2013

Method of Measurement:

Reference FCC document: KDB558074 D01

Make the measurement with the spectrum analyzer's resolution bandwidth (RBW) = 1-5 % of the DTS channel bandwidth and not to exceed 100kHz, video bandwidth (VBW) ≥ 3 x RBW. In order to make an accurate measurement, set the span greater than DTS channel bandwidth. The 6 dB bandwidth must be greater than 500 kHz.

Test Diagram:

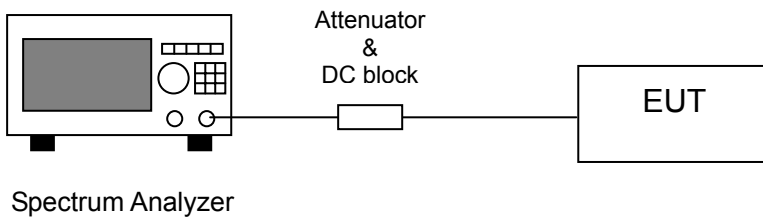

Note: The EUT was tested while in a continuous transmit mode and the worst case data rates are 1 Mbps data rate for 802.11b mode, 6 Mbps data rate for 802.11g mode, 6.5 Mbps data rate for 802.11n HT20 mode and 13.5 Mbps data rate for 802.11n HT40 mode. The EUT was tuned to a low, middle and high channel.



Table: Maximum 6 dB Bandwidth

Mode	Channel	Frequency (MHz)	6dB Bandwidth (MHz)	Min. Limit (MHz)	Pass/Fail
802.11b	1	2412	11.715	0.5	Pass
	6	2437	11.770	0.5	Pass
	11	2462	11.748	0.5	Pass
802.11g	1	2412	16.518	0.5	Pass
	6	2437	16.547	0.5	Pass
	11	2462	16.541	0.5	Pass
Mode	Channel	Frequency (MHz)	6dB Bandwidth (MHz)	Min. Limit (MHz)	Pass/Fail
802.11n HT20	1	2412	17.713	0.5	Pass
	6	2437	17.666	0.5	Pass
	11	2462	17.661	0.5	Pass
802.11n HT40	3	2422	36.344	0.5	Pass
	6	2437	36.002	0.5	Pass
	9	2452	36.100	0.5	Pass

6 dB Bandwidth @ 802.11b mode Channel 1

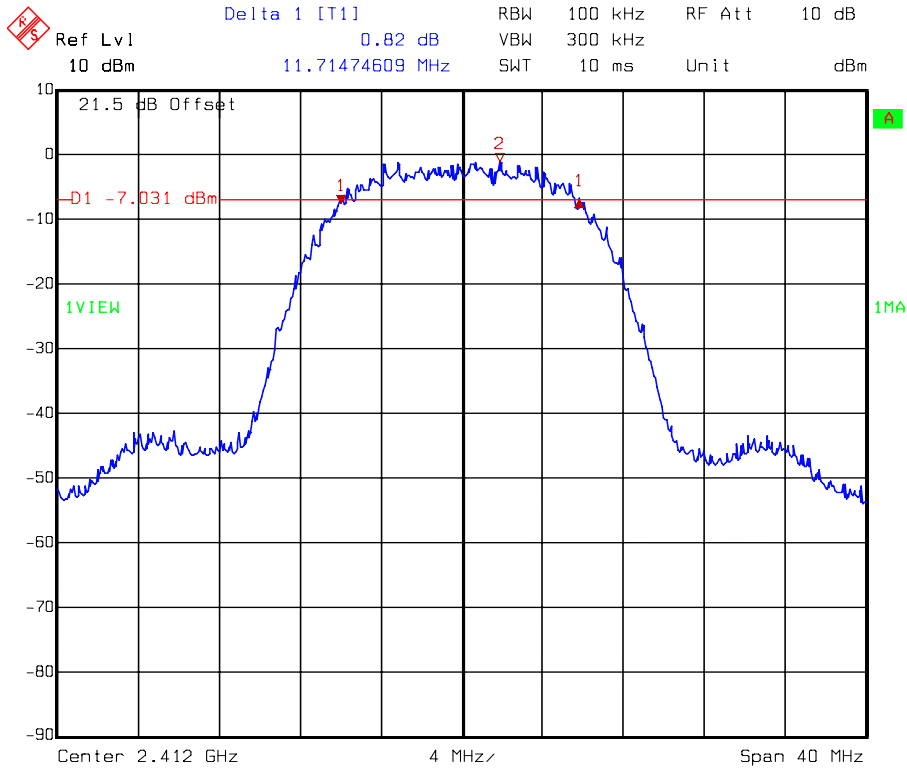

6 dB Bandwidth @ 802.11b mode Channel 6

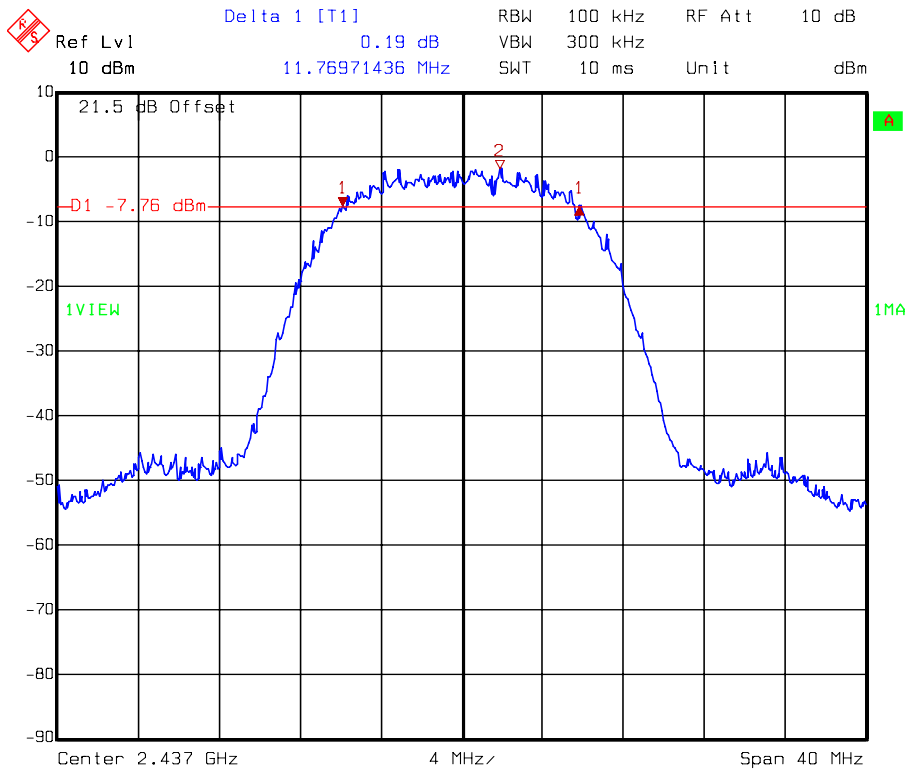

6 dB Bandwidth @ 802.11b mode Channel 11

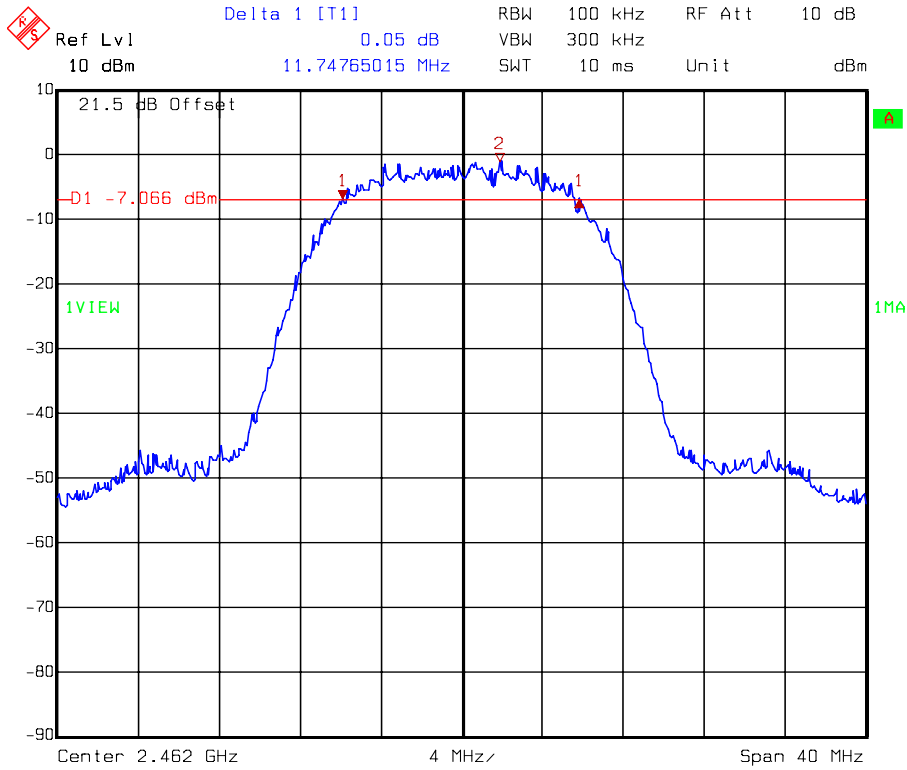

6 dB Bandwidth @ 802.11g mode Channel 1

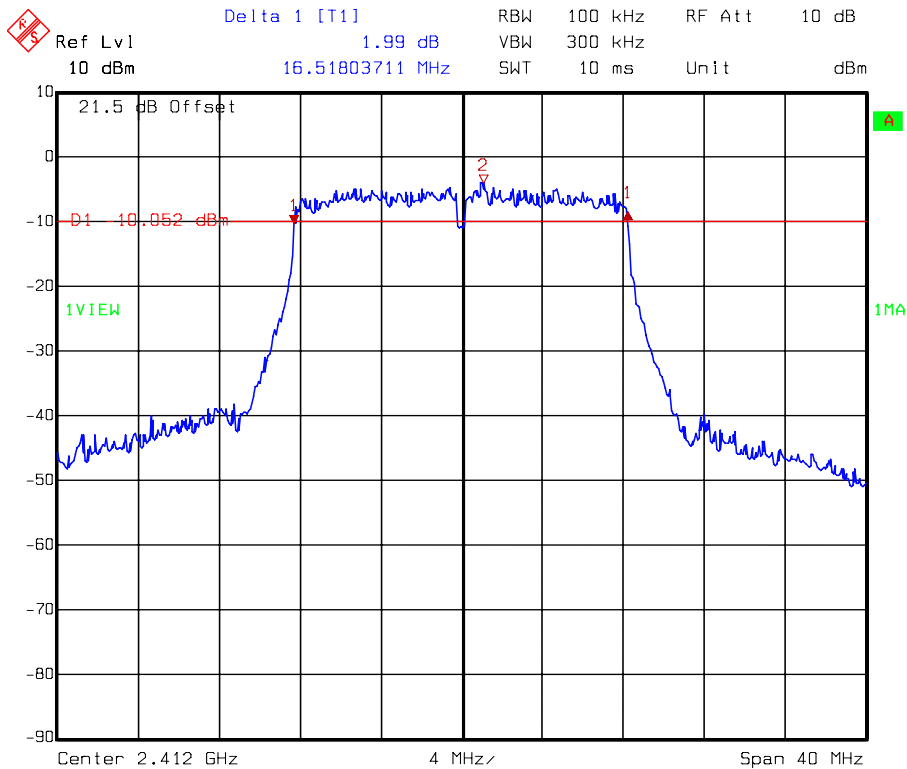

6 dB Bandwidth @ 802.11g mode Channel 6

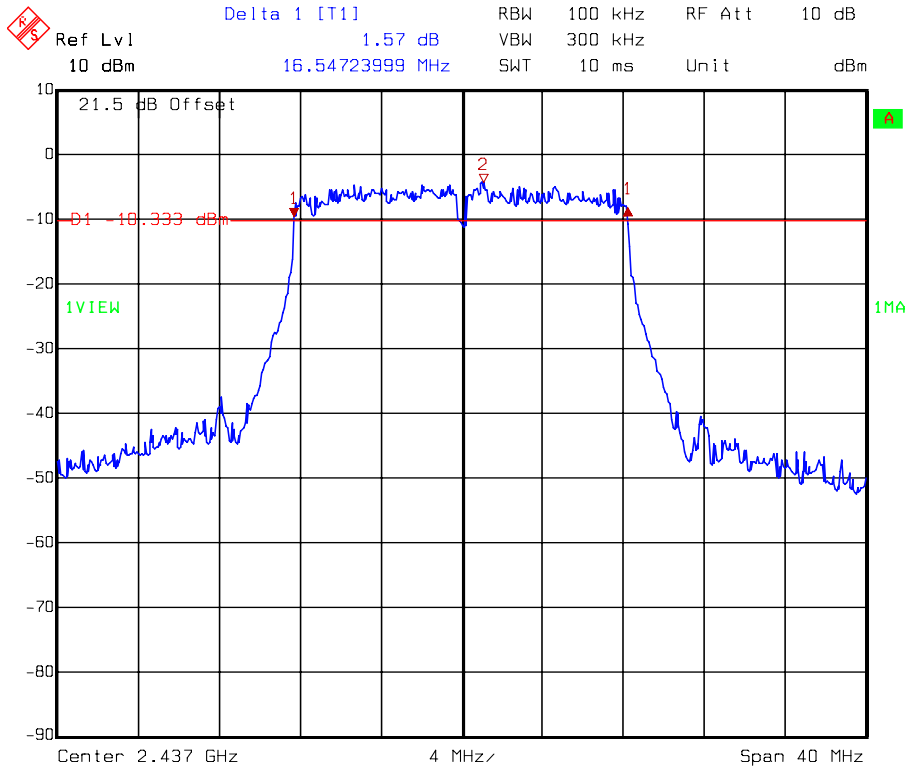

6 dB Bandwidth @ 802.11g mode Channel 11

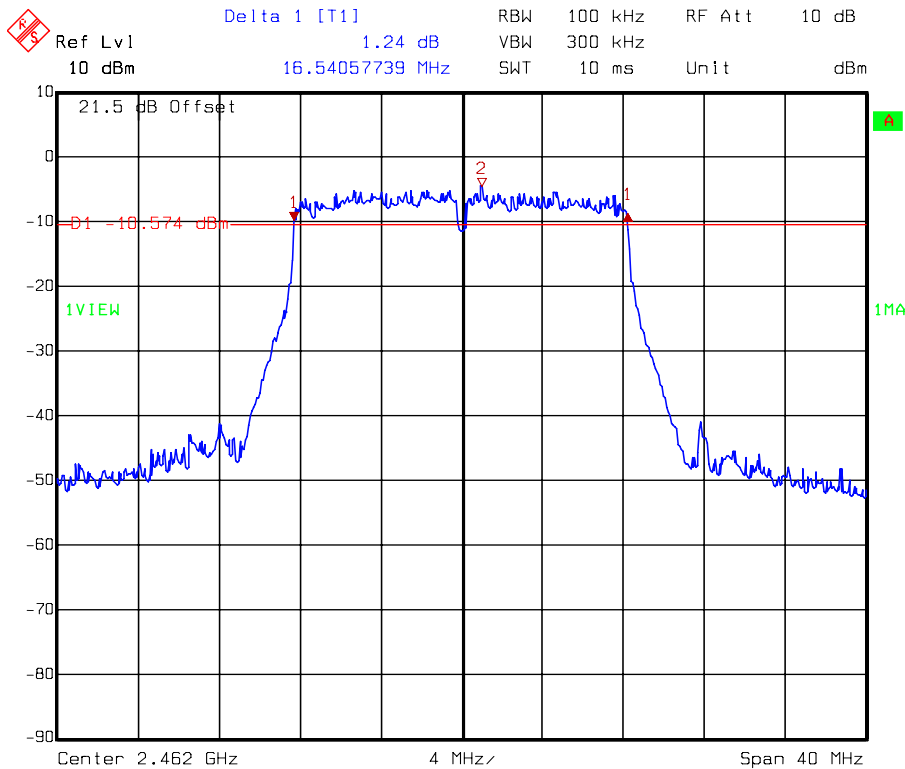

6 dB Bandwidth @ 802.11n HT20 mode Channel 1

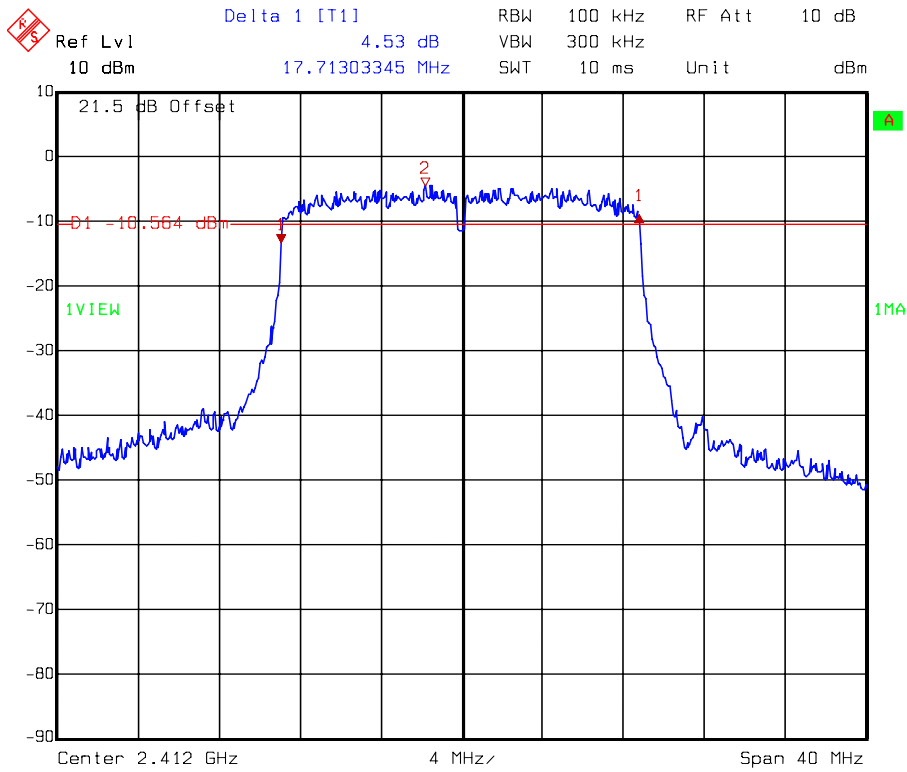

6 dB Bandwidth @ 802.11n HT20 mode Channel 6

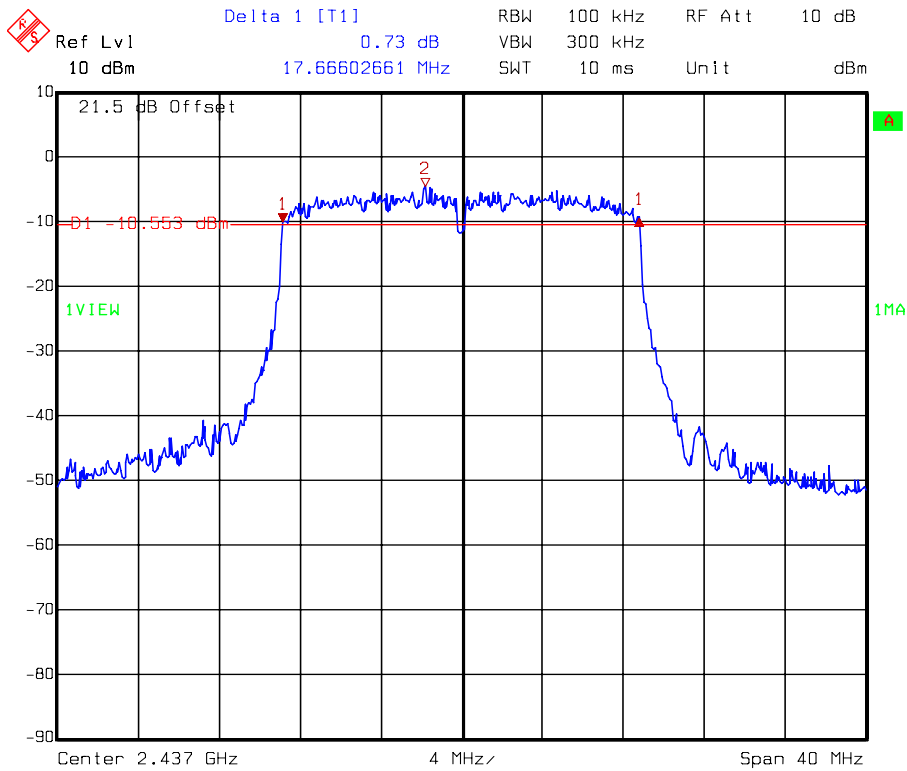

6 dB Bandwidth @ 802.11n HT20 mode Channel 11

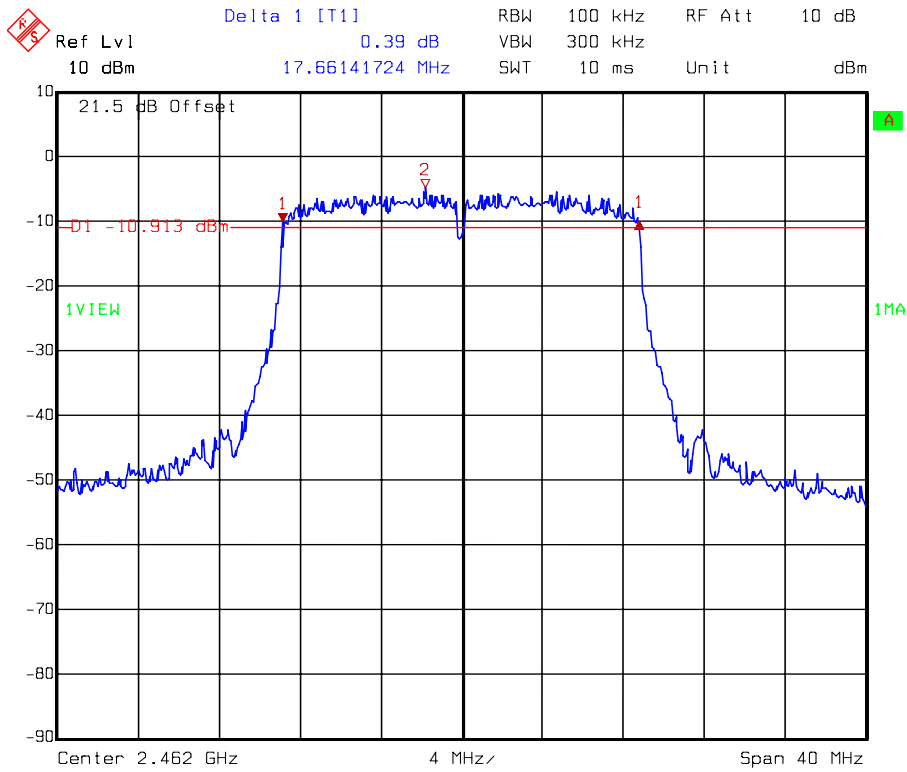

6 dB Bandwidth @ 802.11n HT40 mode Channel 3

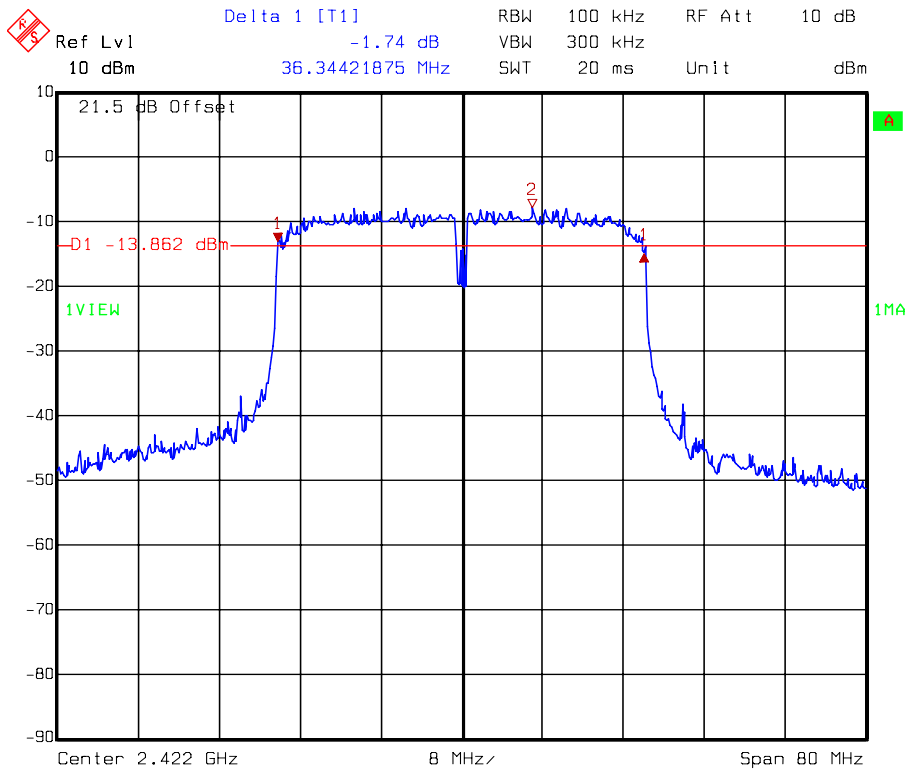

6 dB Bandwidth @ 802.11n HT40 mode Channel 6

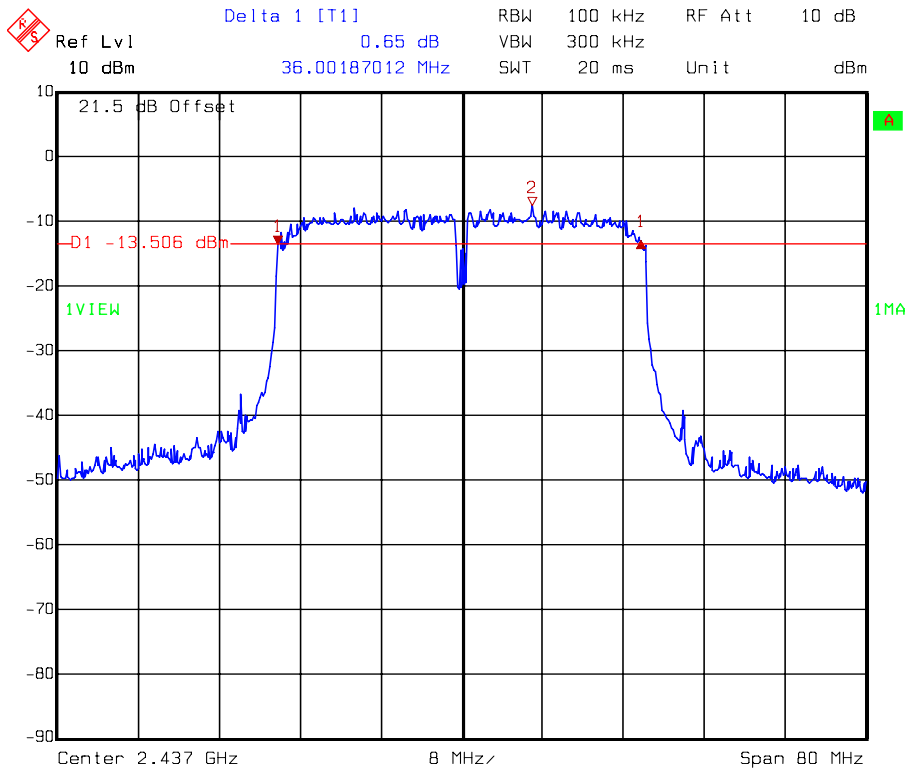

6 dB Bandwidth @ 802.11n HT40 mode Channel 9

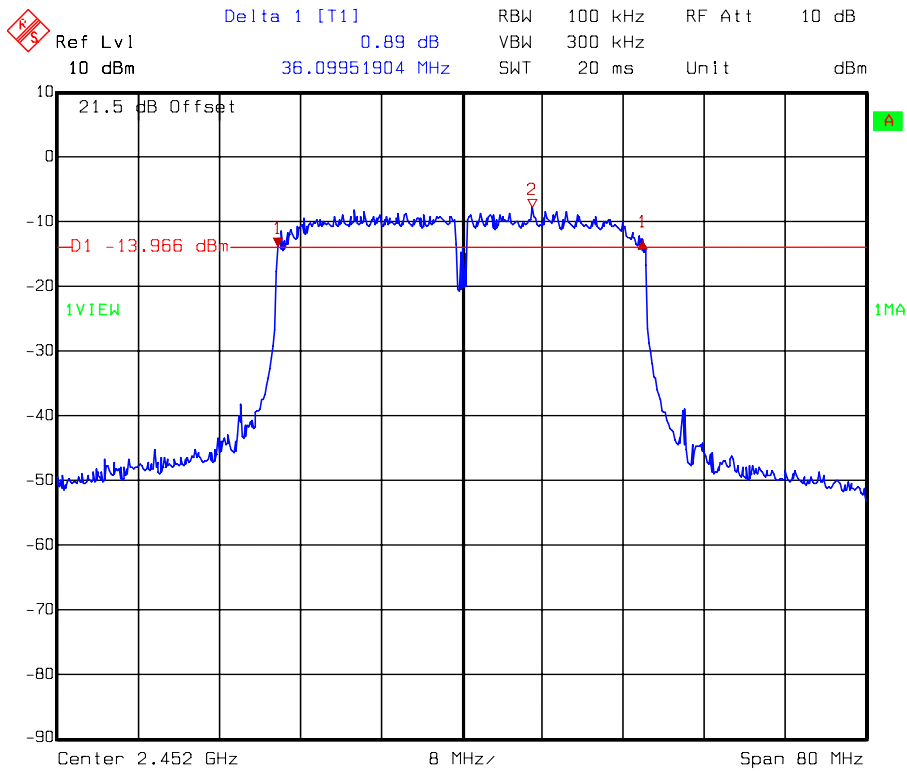

4. 99 % Occupied Bandwidth

Name of Test	99 % Occupied Bandwidth
Base Standard	None; for reporting purposes only

Test Result: Complies
Measurement Data: See Table & plots below
Test Date: Jun. 29, 2013

Method of Measurement:

A portion of the transmitted signal is coupled to a Spectrum Analyzer with a resolution bandwidth of at least 1 % of the bandwidth of the transmitted signal. The resolution bandwidth is chosen so as not to reduce the peak level of the measured waveform. The appropriate bandwidth mask is applied to the output waveform to verify compliance.

Test Diagram:

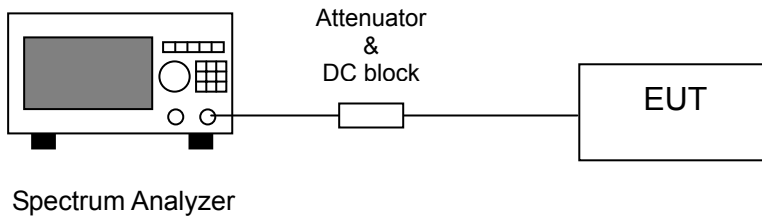

Note: The EUT was tested while in a continuous transmit mode and the worst case data rates are 1 Mbps data rate for 802.11b mode, 6 Mbps data rate for 802.11g mode, 6.5 Mbps data rate for 802.11n HT20 mode and 13.5 Mbps data rate for 802.11n HT40 mode. The EUT was tuned to a low, middle and high channel.

Table: 99 % Occupied Bandwidth

Mode	Channel	Frequency (MHz)	Occupied Bandwidth (MHz)
802.11b	1	2412	14.629
	6	2437	14.729
	11	2462	14.529
802.11g	1	2412	16.834
	6	2437	16.633
	11	2462	16.633
Mode	Channel	Frequency (MHz)	Occupied Bandwidth (MHz)
802.11n HT20	1	2412	17.735
	6	2437	17.735
	11	2462	17.735
802.11n HT40	3	2422	36.072
	6	2437	36.273
	9	2452	36.072

99 % Occupied Bandwidth @ 802.11b mode Channel 1

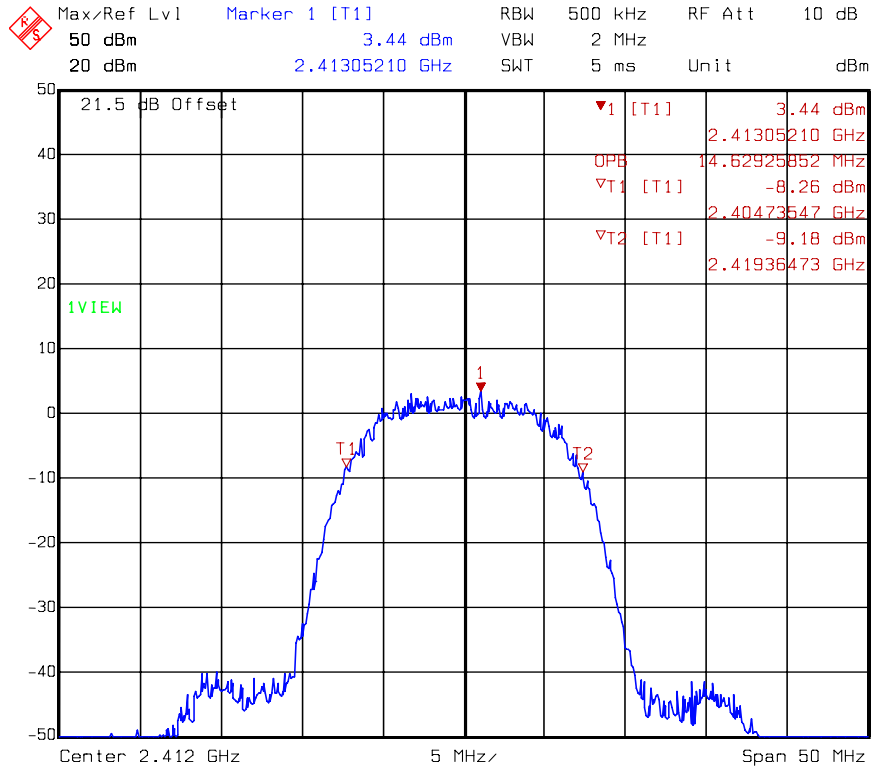

99 % Occupied Bandwidth @ 802.11b mode Channel 6

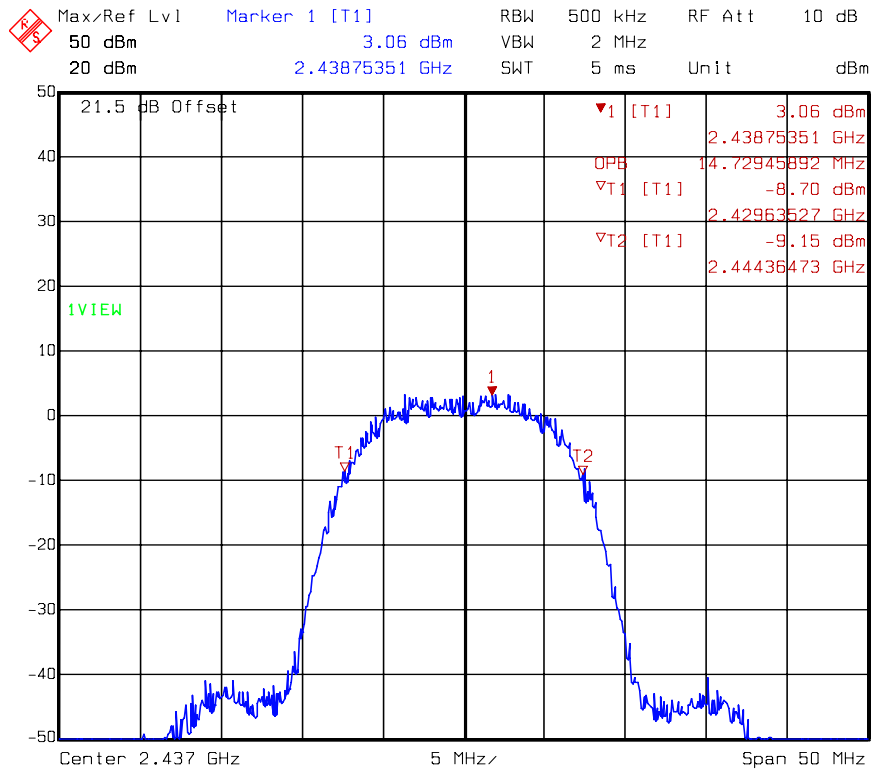

99 % Occupied Bandwidth @ 802.11b mode Channel 11

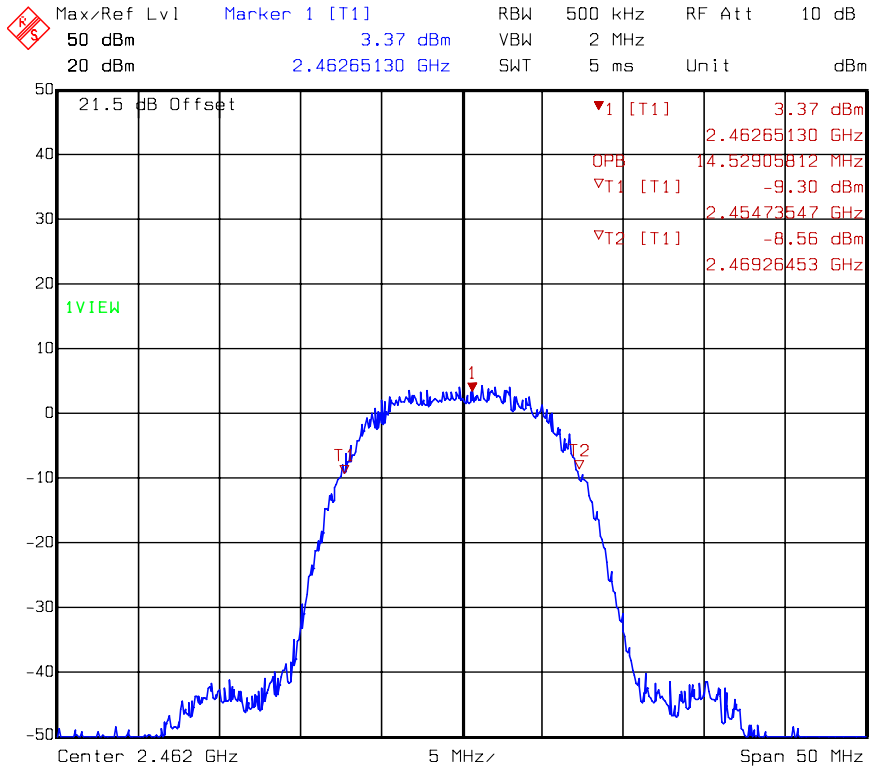

99 % Occupied Bandwidth @ 802.11g mode Channel 1

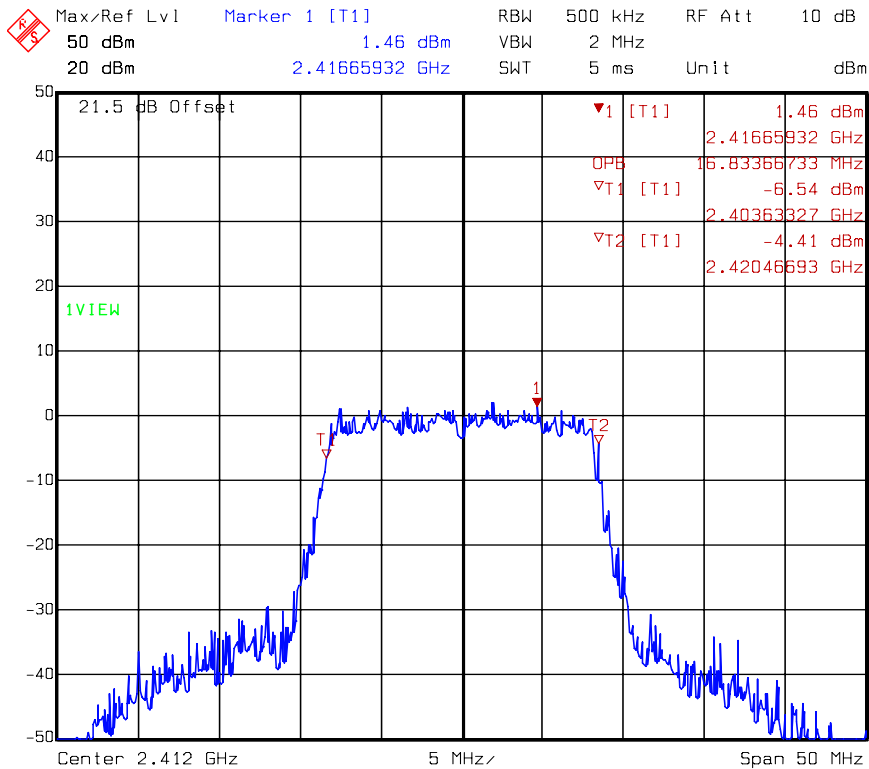

99 % Occupied Bandwidth @ 802.11g mode Channel 6

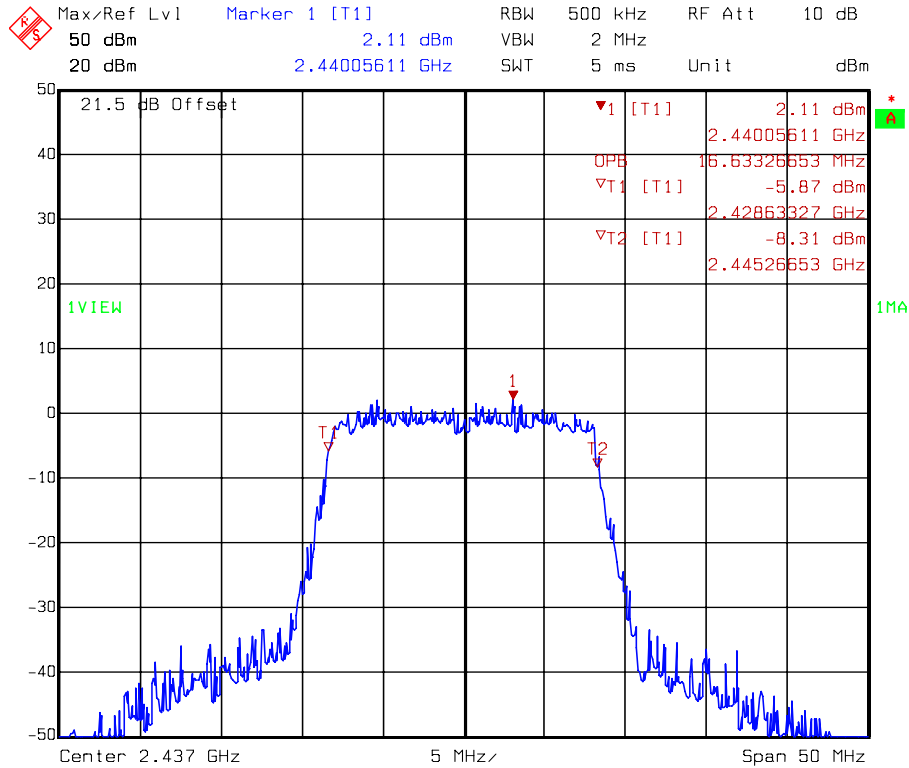

99 % Occupied Bandwidth @ 802.11g mode Channel 11

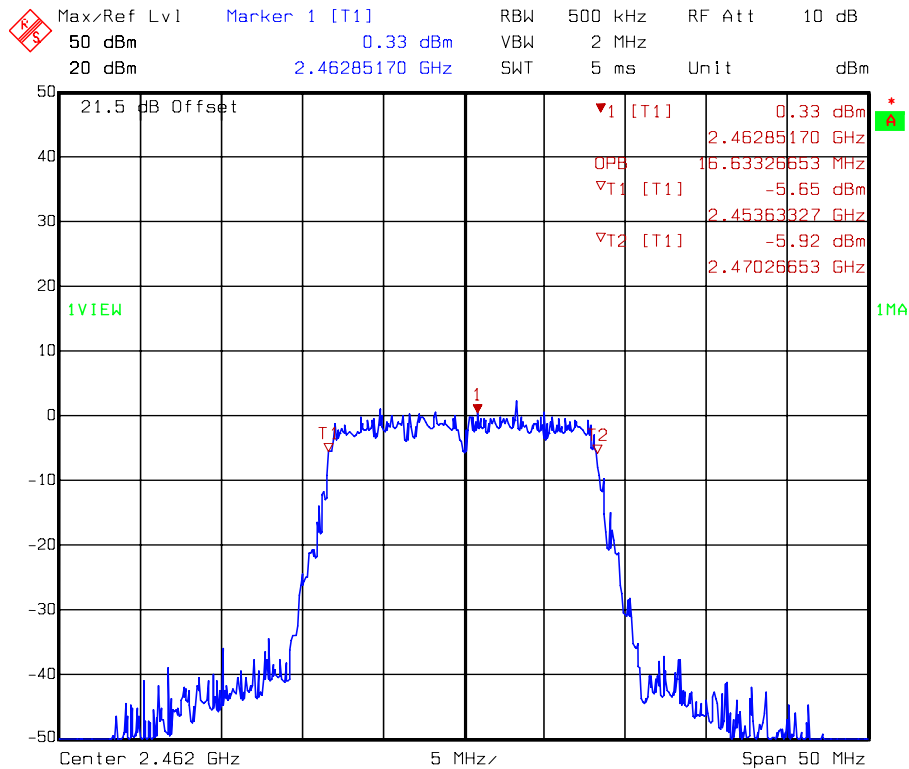

99 % Occupied Bandwidth @ 802.11n HT20 mode Channel 1

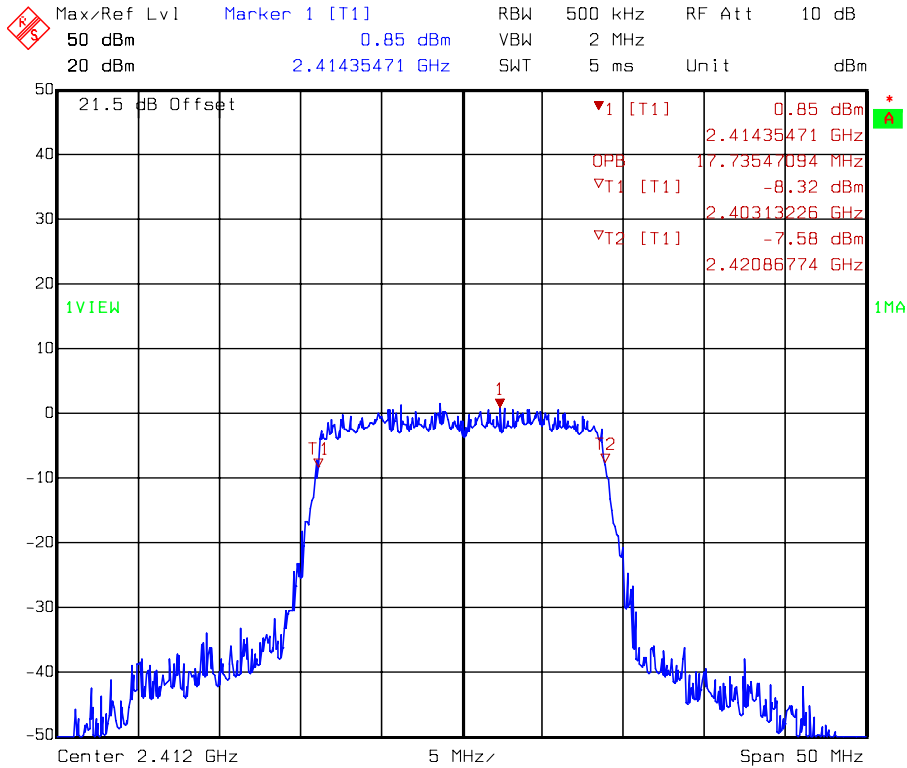

99 % Occupied Bandwidth @ 802.11n HT20 mode Channel 6

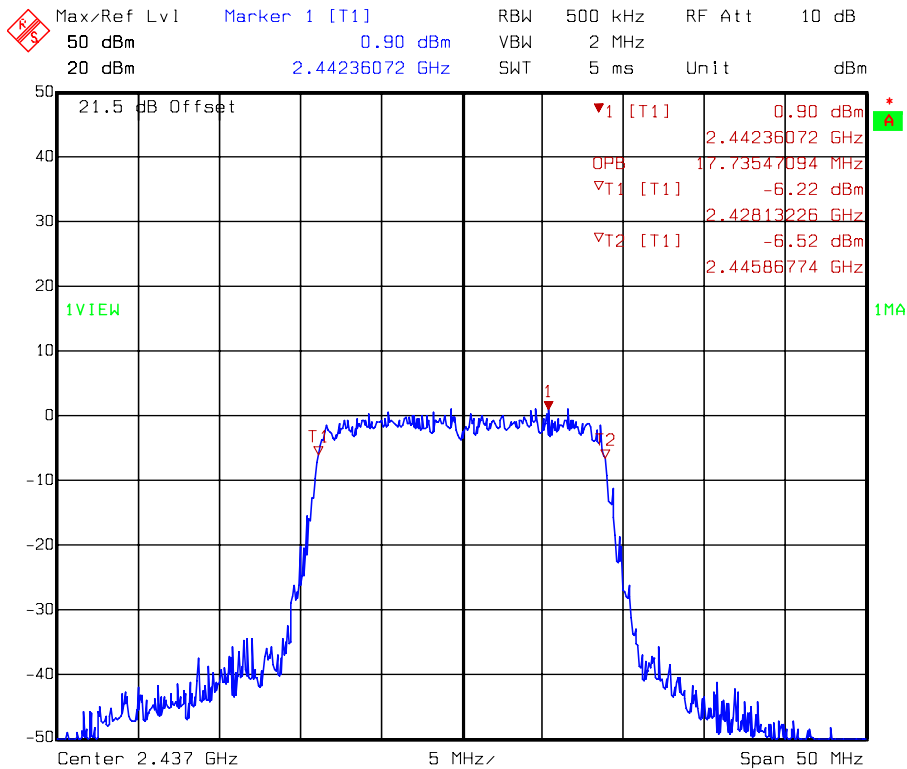

99 % Occupied Bandwidth @ 802.11n HT20 mode Channel 11

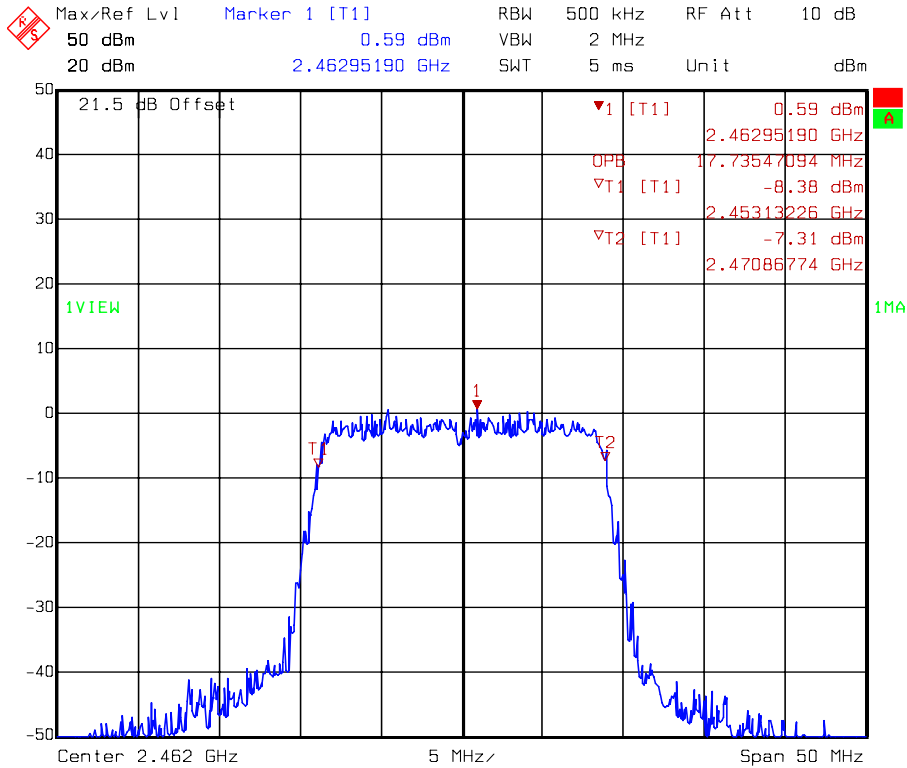

99 % Occupied Bandwidth @ 802.11n HT40 mode Channel 3

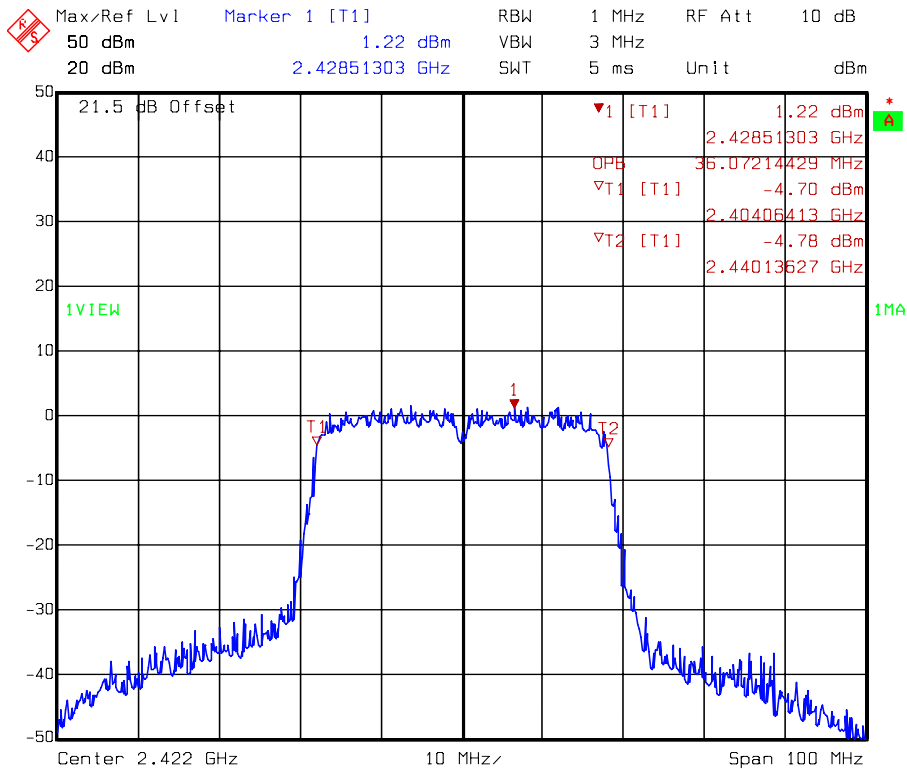

99 % Occupied Bandwidth @ 802.11n HT40 mode Channel 6

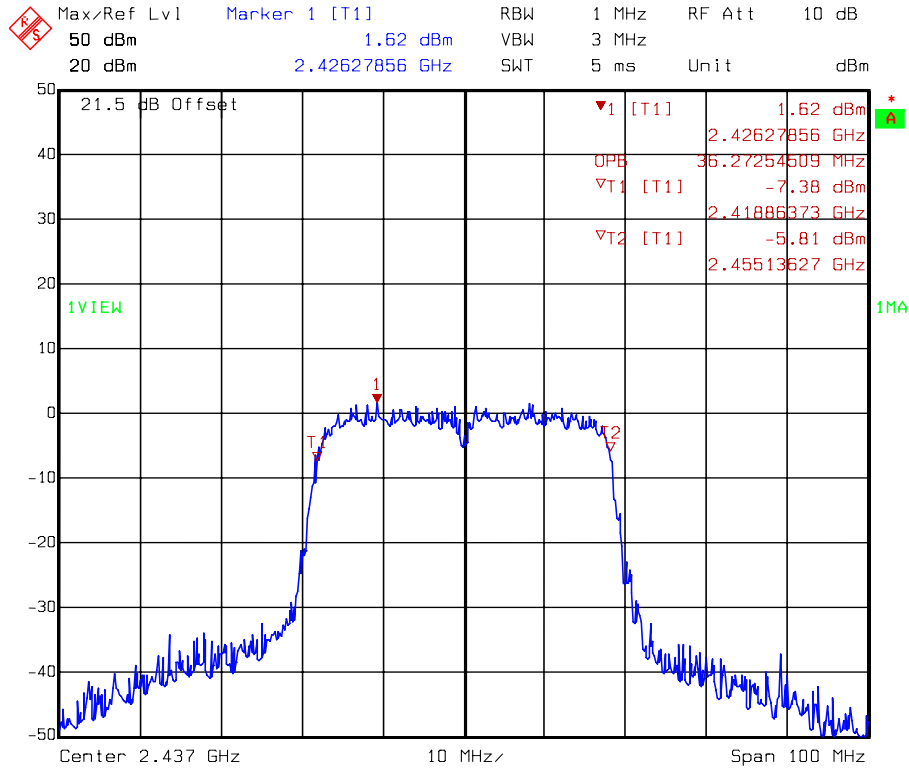

99 % Occupied Bandwidth @ 802.11n HT40 mode Channel 9

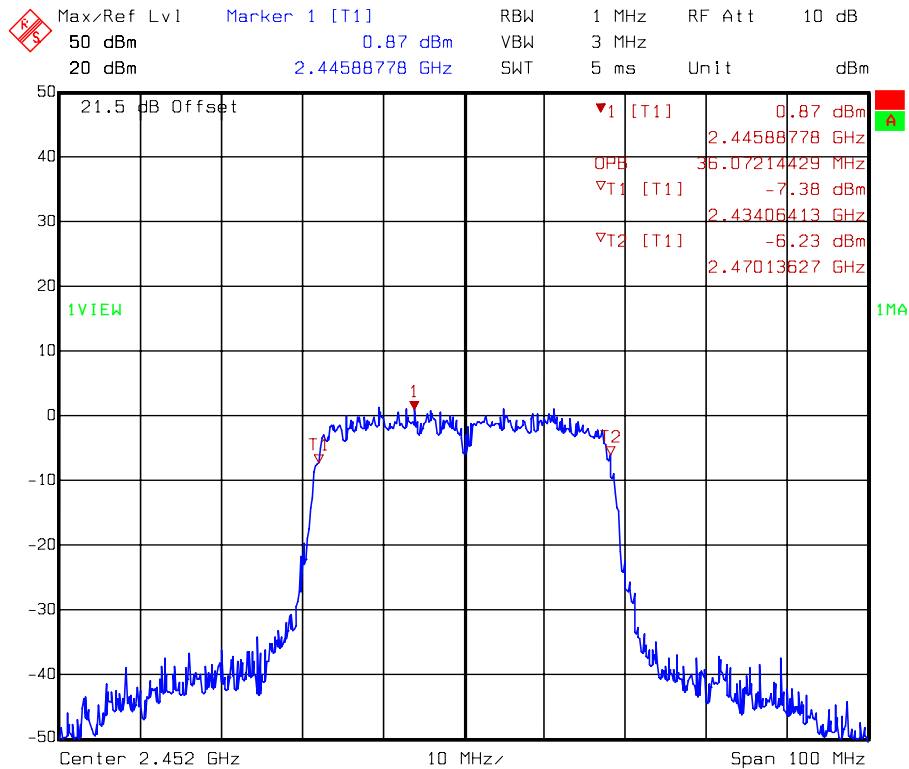

5. Maximum Output Power

Name of Test	Maximum output power
Base Standard	FCC 15.247(b)

Measurement Uncertainty: ±0.392 dB (k=2)

Test Result: Complies

Measurement Data: See Table below

Test Date: Jun. 29, 2013

Method of Measurement:

Reference FCC document: KDB558074 D01

The power output was measured on the EUT using a 50 ohm SMA Cable connected to peak and average power meter via power sensor. Connect the 20 dB attenuator and DC block at the input port of the power sensor. Measure the conducted transmitting power at each antenna port. Power output was measured with the maximum rated input level.

Test Diagram:

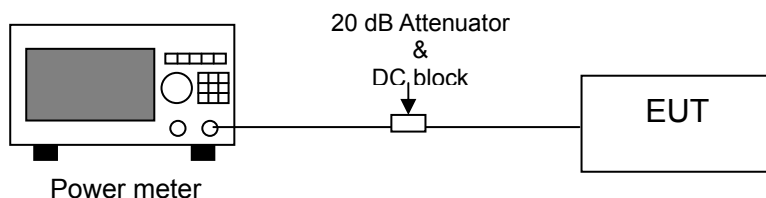

Note 1: §15.247 (b) (4) Except as shown in paragraphs (b)(3) (i), (ii) and (iii) of this section, if transmitting antennas of directional gain greater than 6 dBi are used the peak output power from the intentional radiator shall be reduced below the stated values in paragraphs (b)(1) or (b)(2) of this section, as appropriate, by the amount in dB that the directional gain of the antenna exceeds 6 dBi.

Table: Maximum output power

Mode	Channel	Frequency (MHz)	Output Power (dBm)	Total Calculated Power (mW)	Limit (dBm)	Margin (dB)
			PK	PK		
802.11b	1	2412	15.34	34.20	30	-14.66
	6	2437	15.53	35.73	30	-14.47
	11	2462	15.92	39.08	30	-14.08
802.11g	1	2412	20.19	104.47	30	-9.81
	6	2437	20.91	123.31	30	-9.09
	11	2462	19.22	83.56	30	-10.78
Mode	Channel	Frequency (MHz)	Output Power (dBm)	Total Calculated Power (mW)	Limit (dBm)	Margin (dB)
			PK	PK		
802.11n HT20	1	2412	19.05	80.35	30	-10.95
	6	2437	18.86	76.91	30	-11.14
	11	2462	18.27	67.14	30	-11.73
802.11n HT40	3	2422	19.29	84.92	30	-10.71
	6	2437	19.10	81.28	30	-10.90
	9	2452	19.65	92.26	30	-10.35

6. Power Spectral Density

Name of Test	Power Spectral Density
Base Standard	FCC 15.247(e)

Test Result: Complies
Measurement Data: See Table & plots below
Test Date: Jun. 29, 2013

Method of Measurement:

Reference FCC document: KDB558074 D01

The power spectrum density was measured from the antenna port of the EUT using a 50 ohm spectrum analyzer. Set RBW = 100 kHz, VBW \geq 300 kHz, sweep= auto couple. The peak level measured must be no greater than + 8 dBm. Power spectrum density was read directly and cable loss (1 dB)/external attenuator (20 dB) correction was added to the reading to obtain power at the EUT antenna terminals.

Test Diagram:

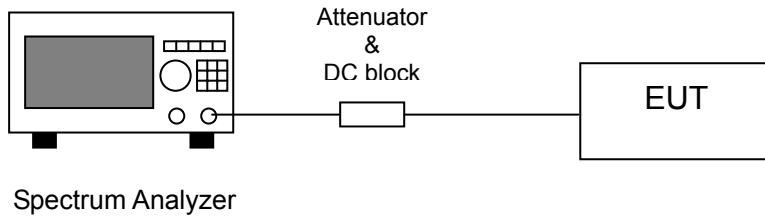
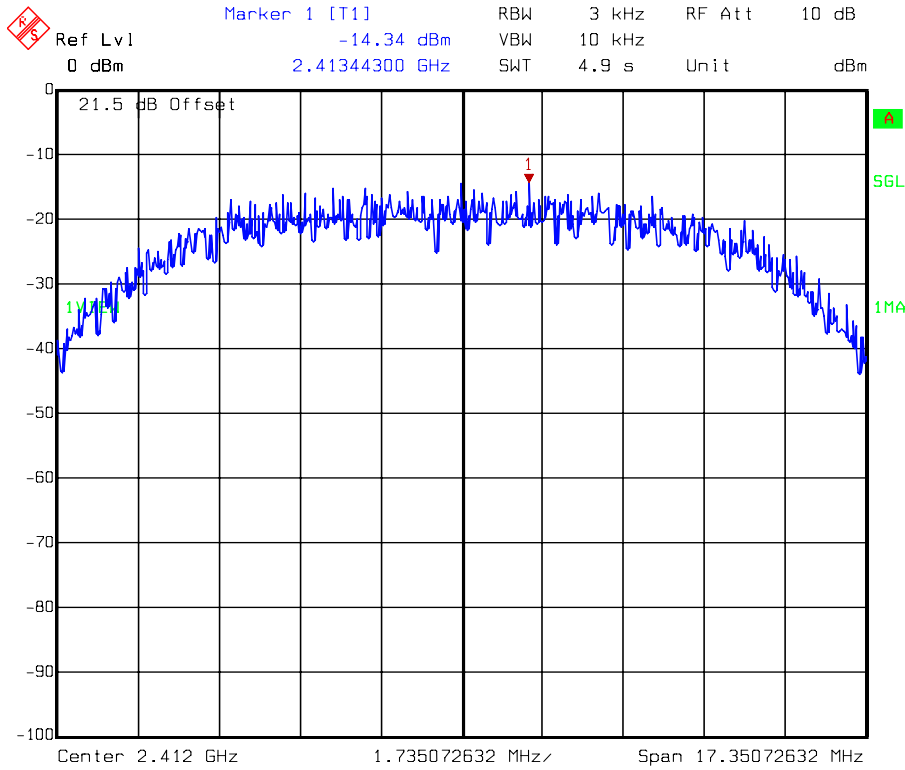

Table: Power Spectral Density

Mode	Channel	Frequency (MHz)	PSD (dBm)	PSD (mW)	Limit (dBm)	Margin (dB)
802.11b	1	2412	-14.342	0.04	8	-22.34
	6	2437	-15.44	0.03	8	-23.44
	11	2462	-14.484	0.04	8	-22.48
802.11g	1	2412	-17.793	0.02	8	-25.79
	6	2437	-17.893	0.02	8	-25.89
	11	2462	-18.35	0.01	8	-26.35
802.11n HT20	1	2412	-17.35	0.02	8	-25.35
	6	2437	-17.852	0.02	8	-25.85
	11	2462	-18.237	0.02	8	-26.24
802.11n HT40	3	2422	-18.696	0.01	8	-26.70
	6	2437	-18.841	0.01	8	-26.84
	9	2452	-19.26	0.01	8	-27.26

Power Spectral Density @ 802.11b mode Channel 1



Power Spectral Density @ 802.11b mode Channel 6

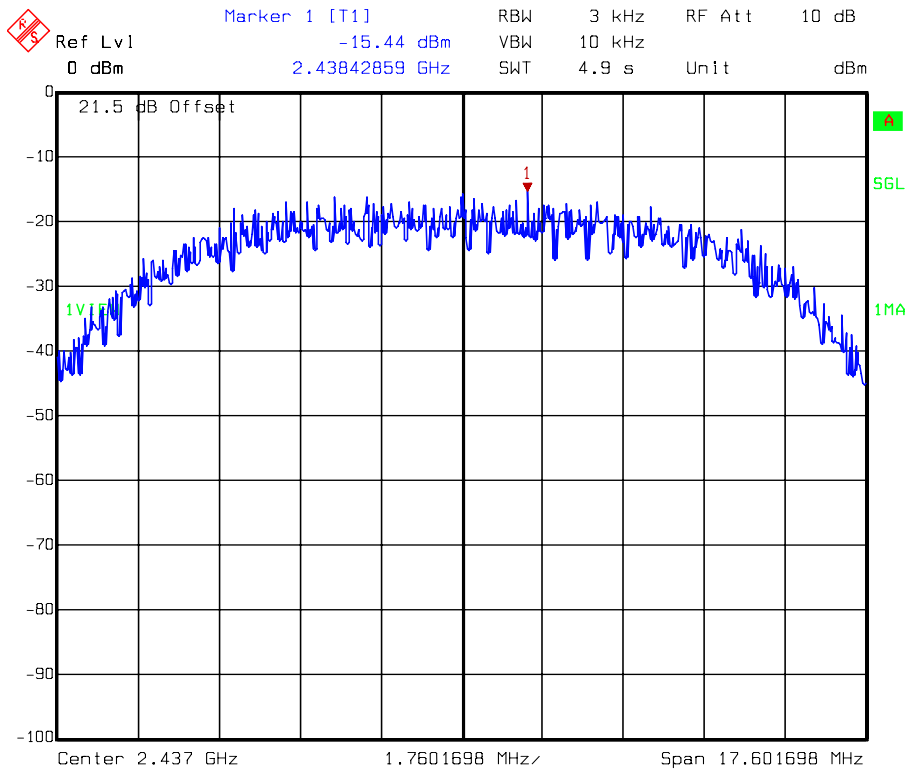

Power Spectral Density @ 802.11b mode Channel 11

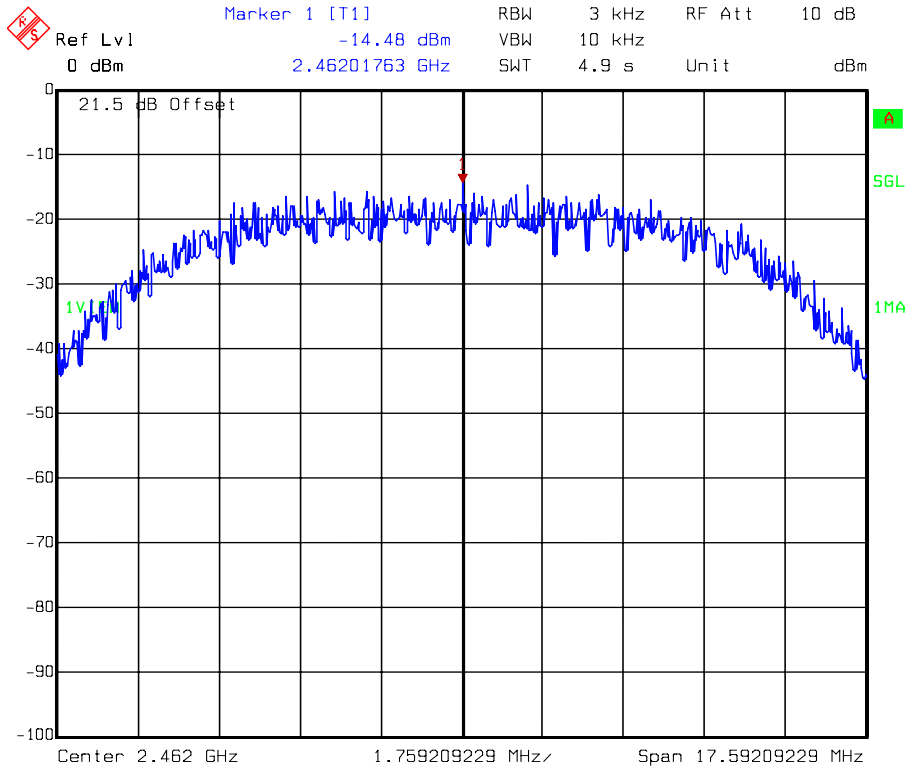

Power Spectral Density @ 802.11g mode Channel 1

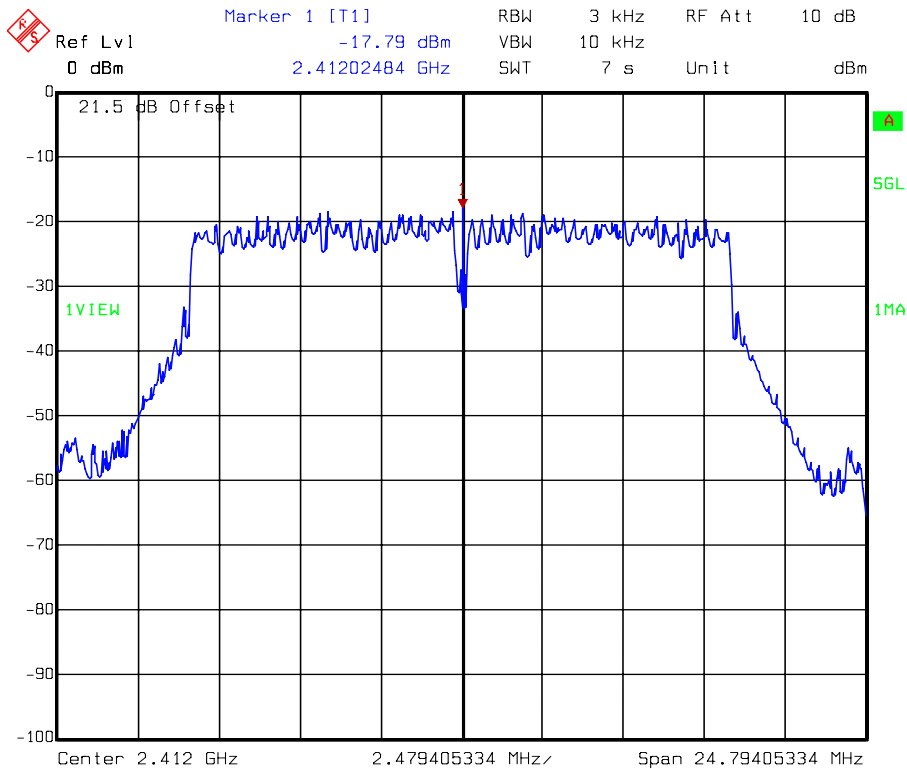

Power Spectral Density @ 802.11g mode Channel 6

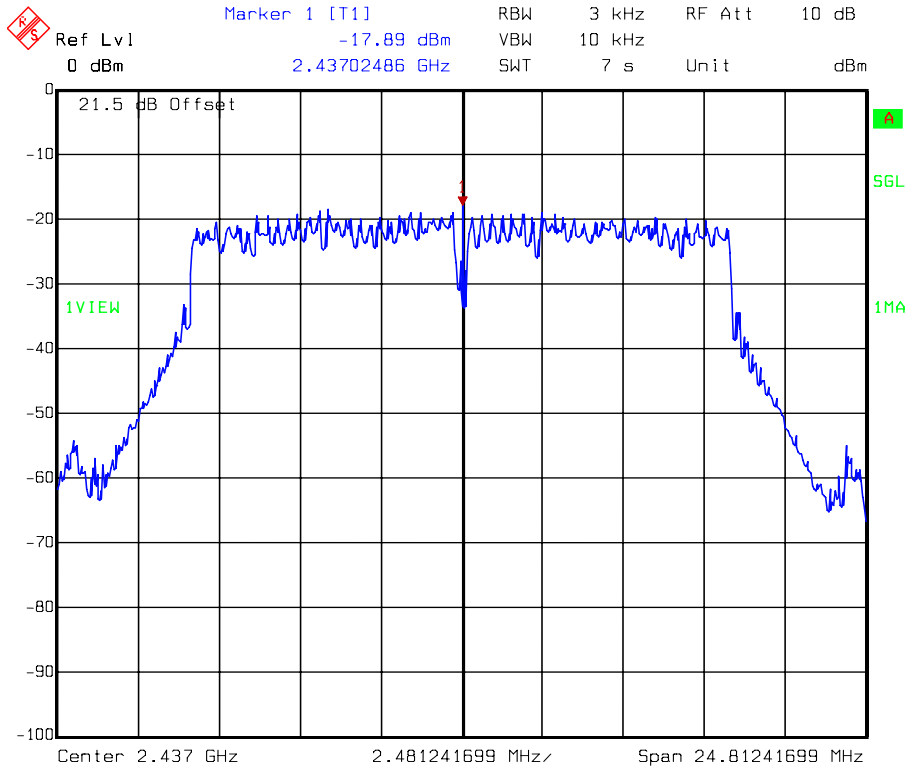

Power Spectral Density @ 802.11g mode Channel 11

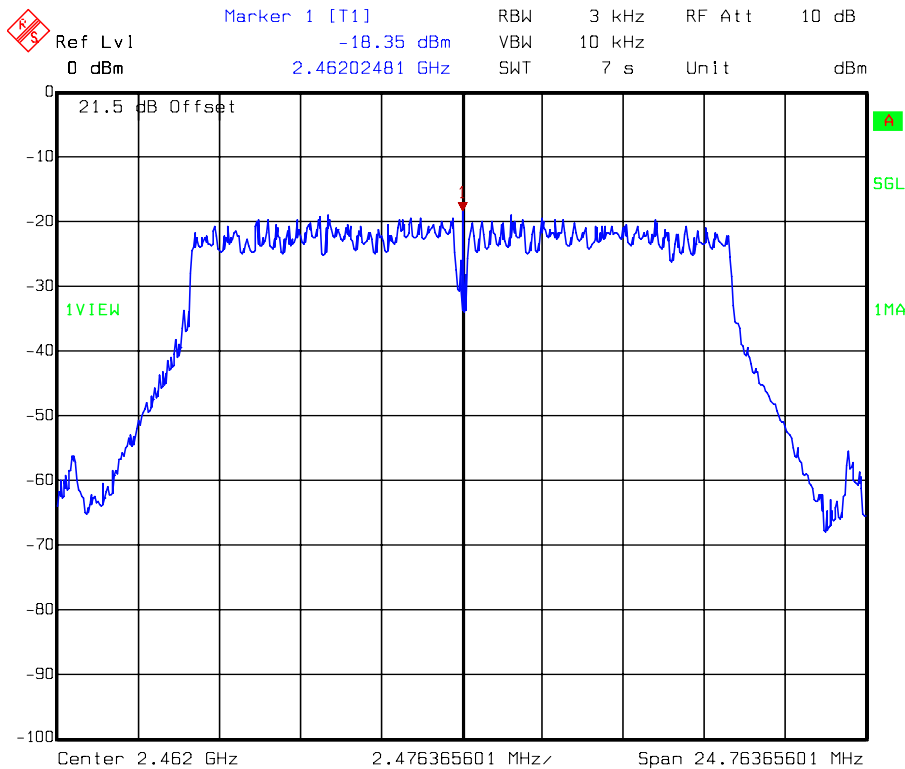

Power Spectral Density @ 802.11n HT20 mode Channel 1

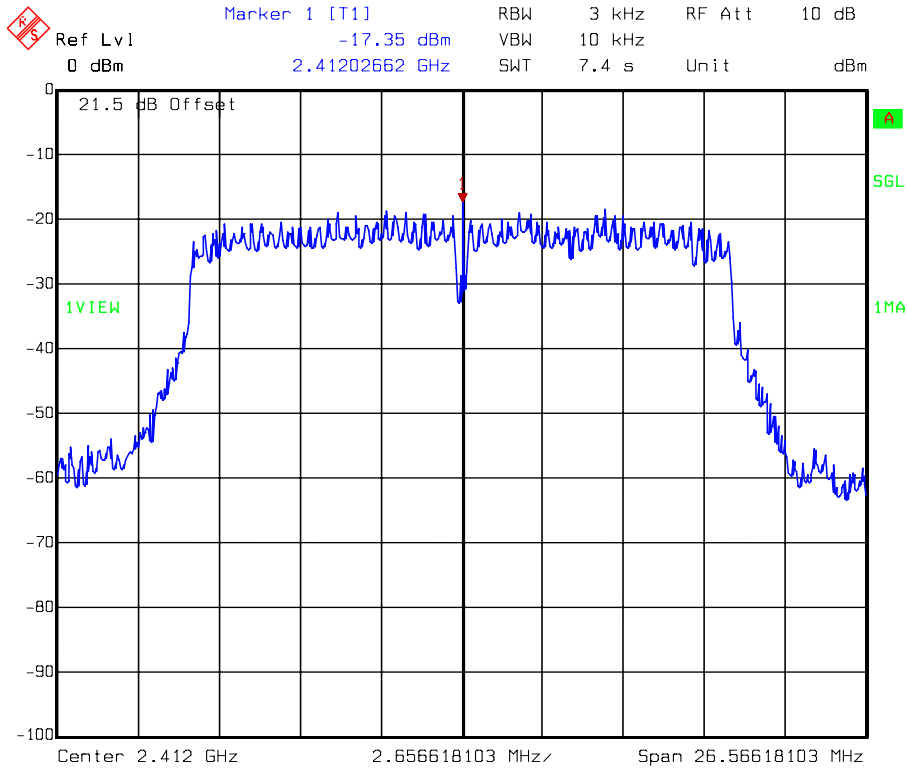

Power Spectral Density @ 802.11n HT20 mode Channel 6

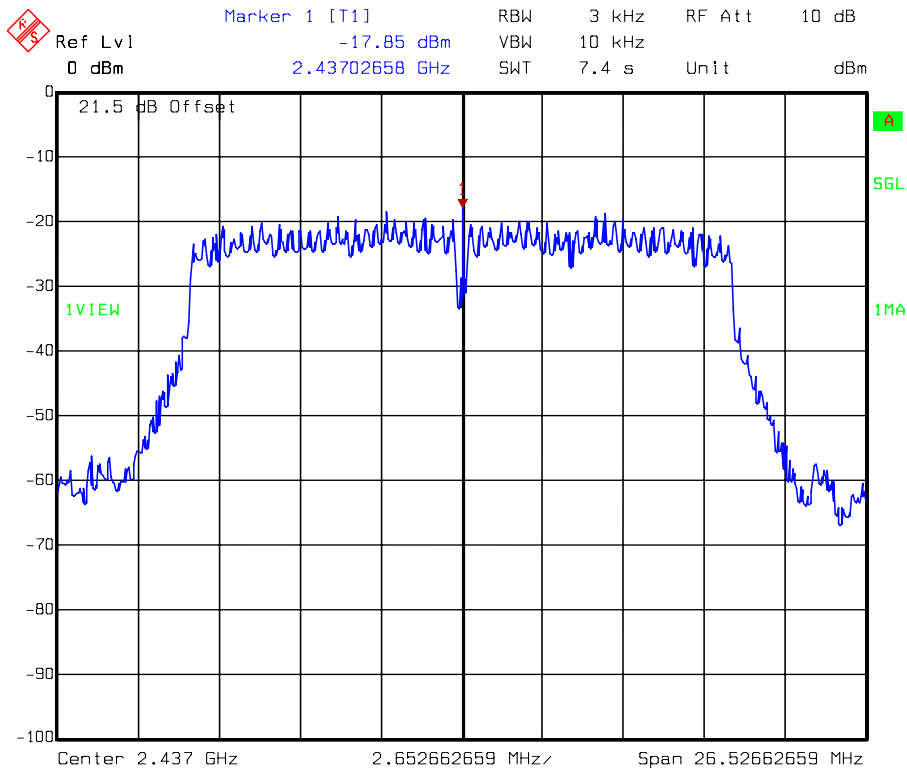

Power Spectral Density @ 802.11n HT20 mode Channel 11

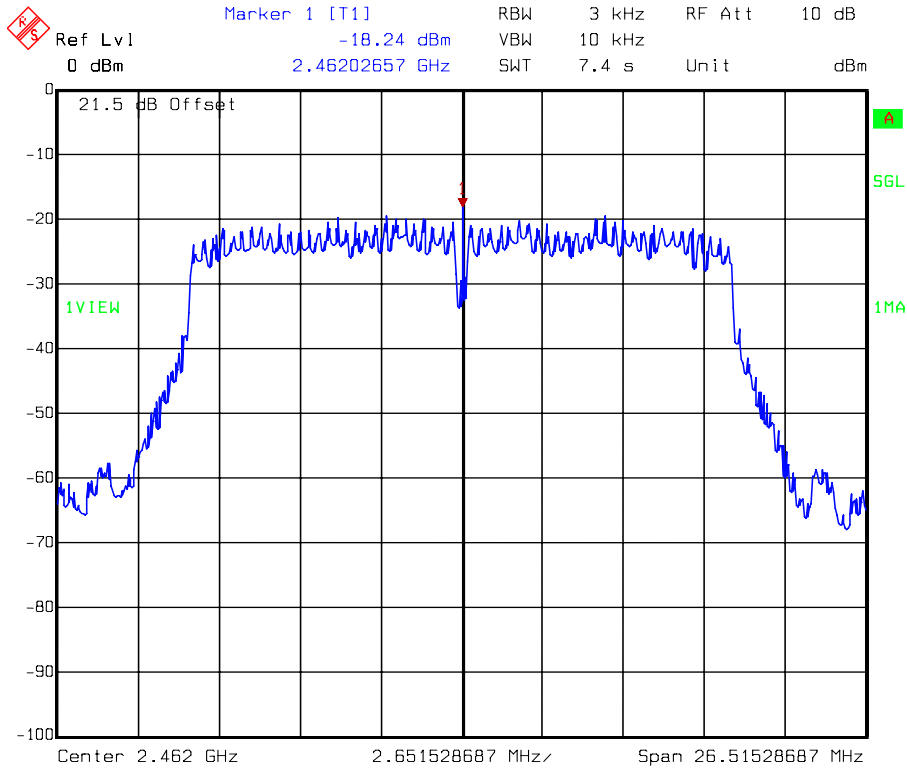

Power Spectral Density @ 802.11n HT40 mode Channel 3

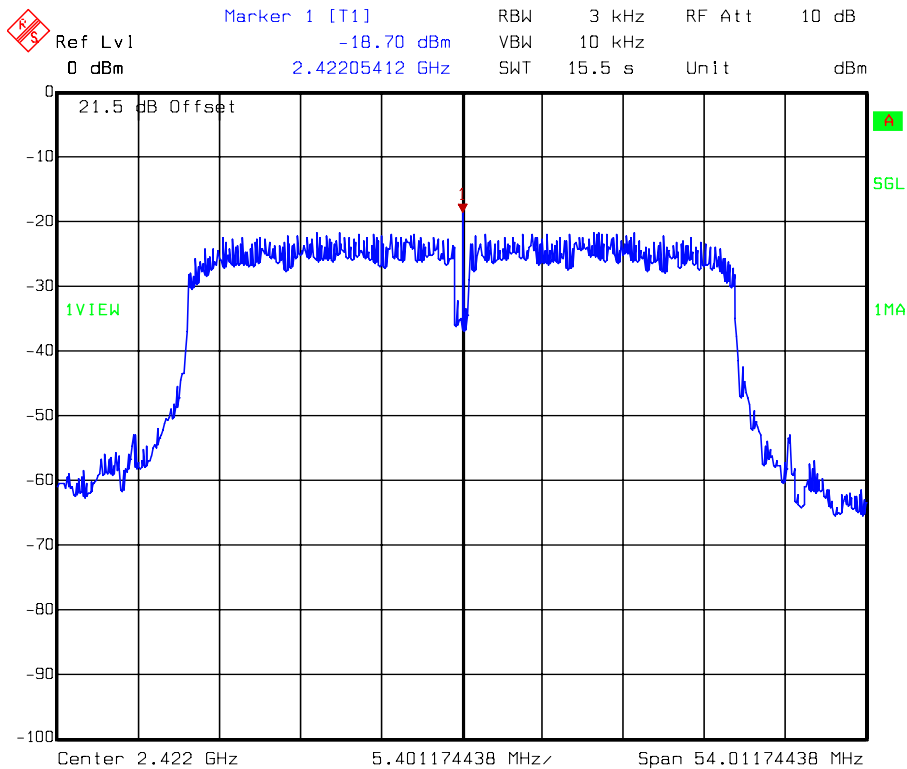

Power Spectral Density @ 802.11n HT40 mode Channel 6

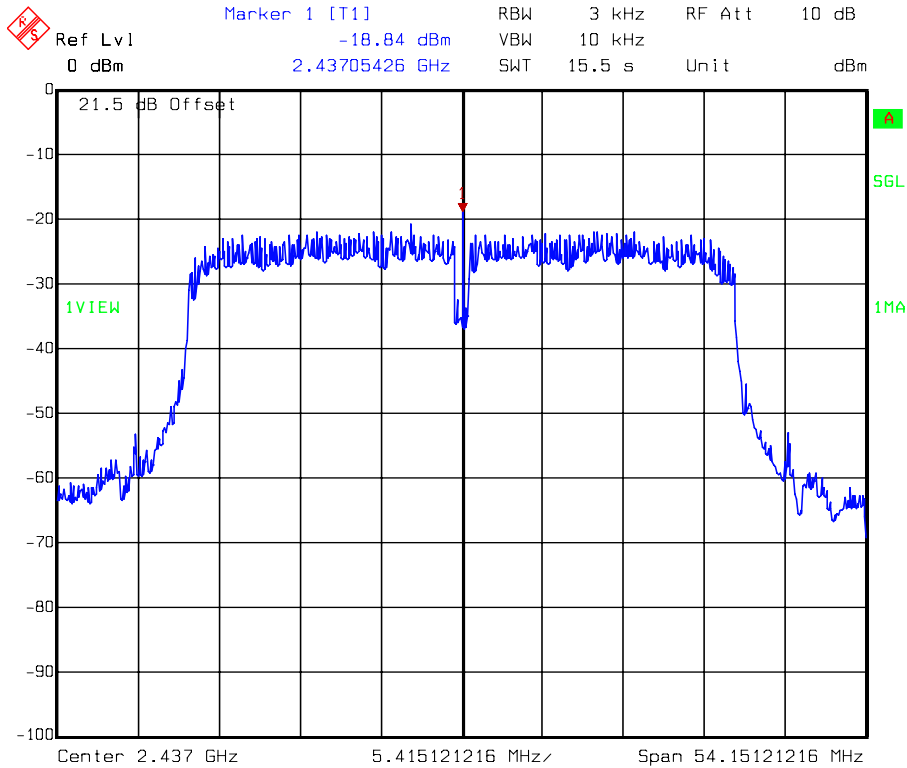

Power Spectral Density @ 802.11n HT40 mode Channel 9

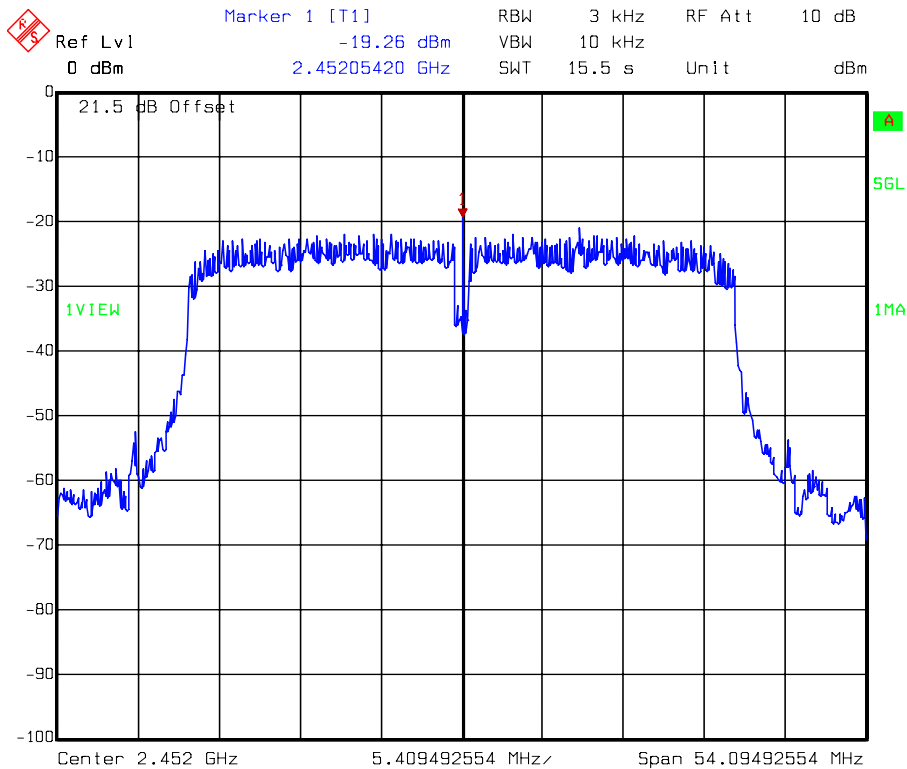

7. RF Antenna Conducted Spurious

Name of Test	RF Antenna Conducted Spurious
Base Standard	FCC 15.247(d)

Test Result: Complies
Measurement Data: See plots below
Test Date: Jun. 29, 2013

Method of Measurement:

Reference FCC document: KDB558074 D01

The measurements were performed from 12 MHz to 25 GHz RF antenna conducted per FCC 15.247 (d) was measured from the EUT antenna port using a 50 ohm spectrum analyzer with the resolution bandwidth set at 100 kHz, and the video bandwidth set at 300 kHz. Harmonics and spurious noise must be at least 20 dB down from the highest emission level within the authorized band as measured with a 100 kHz RBW. The table below is the results from the highest emission for each channel within the authorized band. This table was used to determine the spurious limits for each channel. If maximum (average) conducted output power was used to demonstrate compliance to **15.247(b)(3)** requirements, then the peak power in any 100 kHz bandwidth outside of the authorized frequency band shall be attenuated by at least 30 dB relative to the maximum in-band peak PSD level in 100 kHz.

Test Diagram:

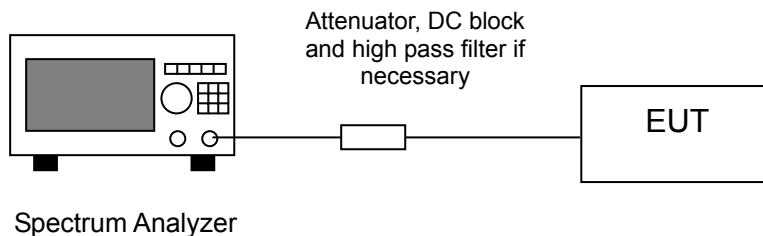

Conducted spurious @ 802.11b mode Channel 1 (1 of 3)

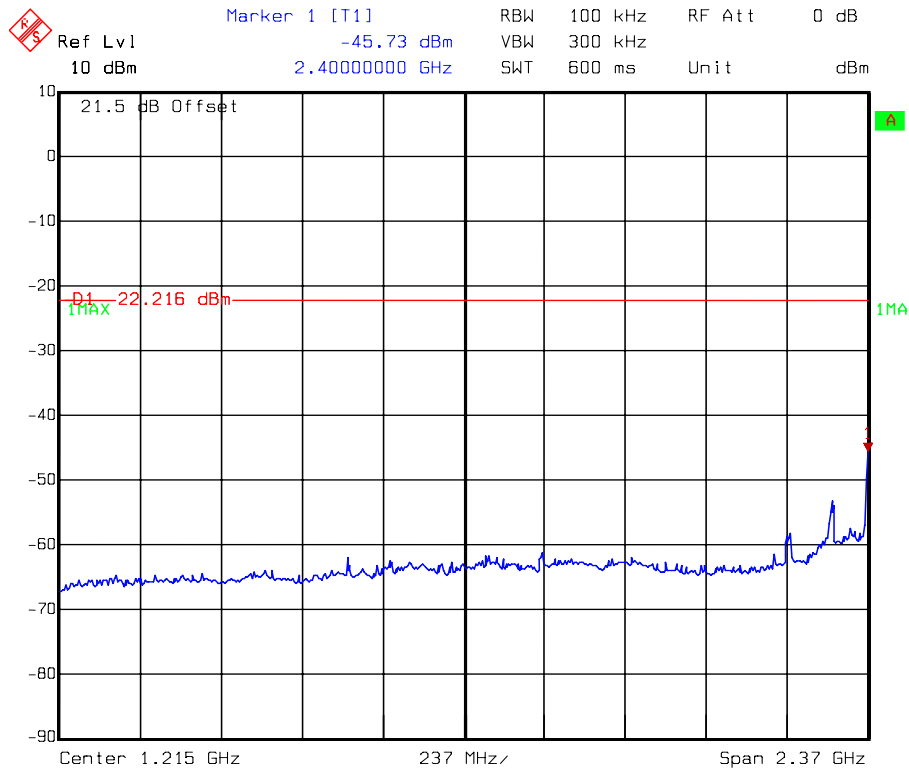

Conducted spurious @ 802.11b mode Channel 1 (2 of 3)

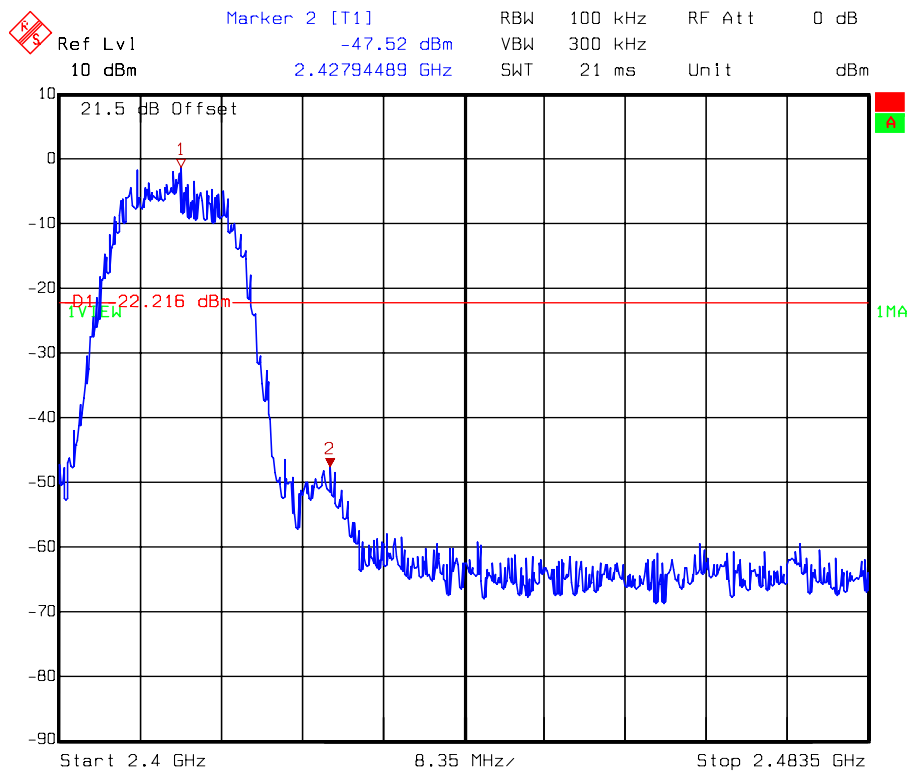

Conducted spurious @ 802.11b mode Channel 1 (3 of 3)

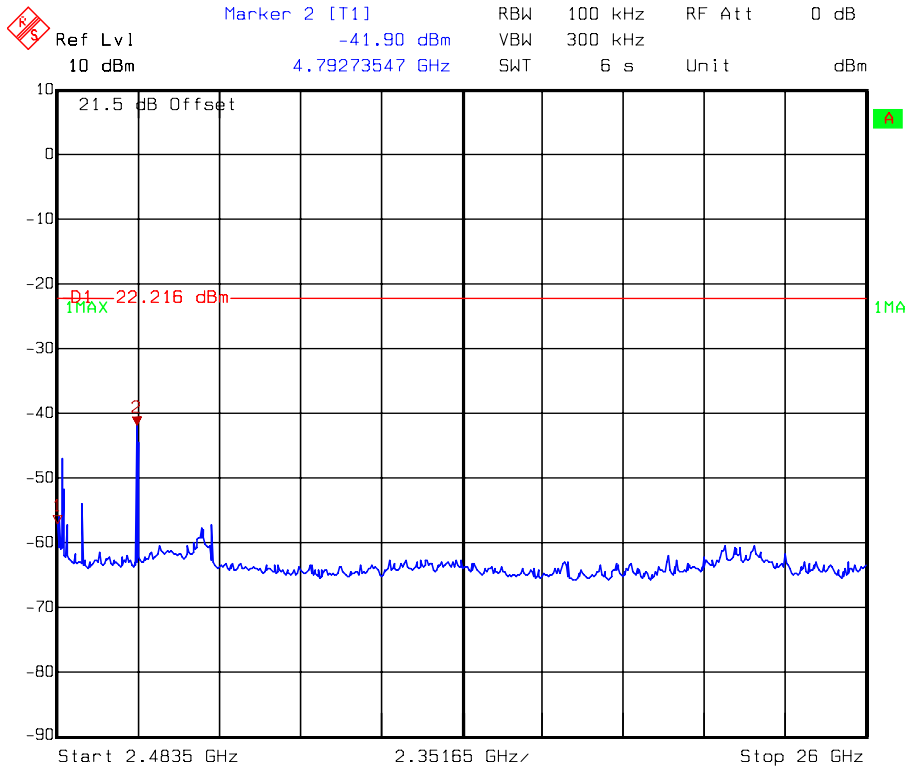

Conducted spurious @ 802.11b mode Channel 6 (1 of 3)

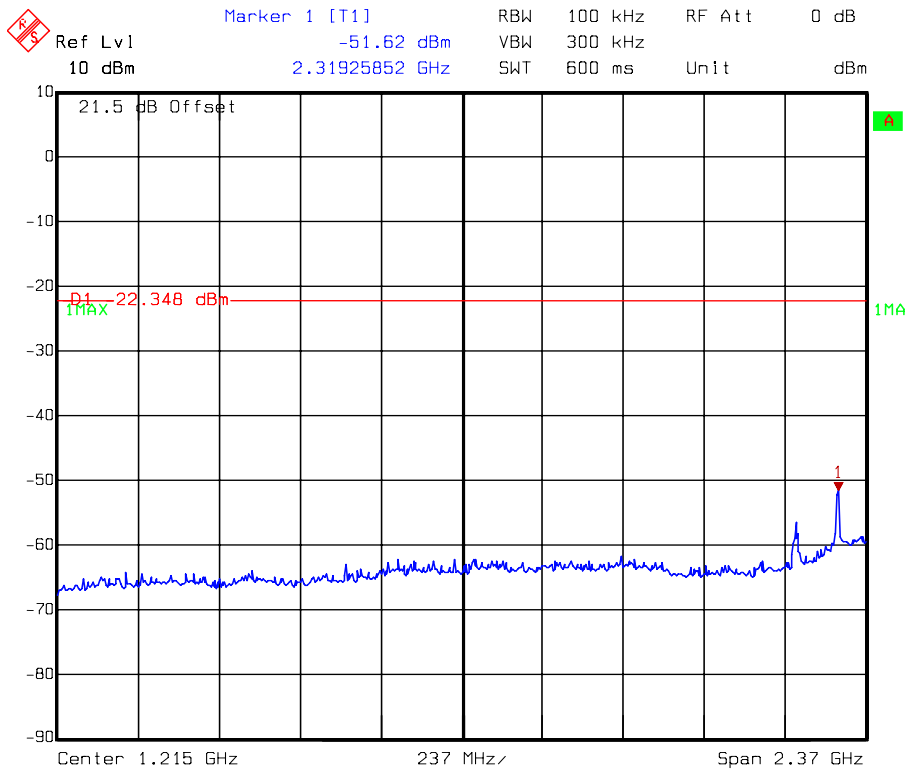

Conducted spurious @ 802.11b mode Channel 6 (2 of 3)

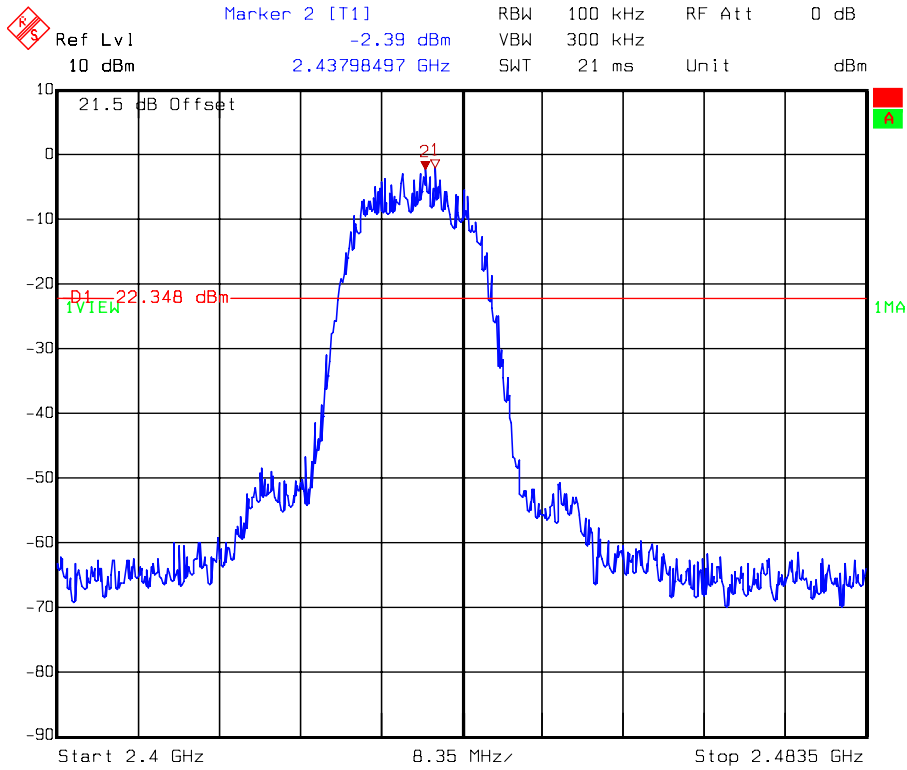

Conducted spurious @ 802.11b mode Channel 6 (3 of 3)

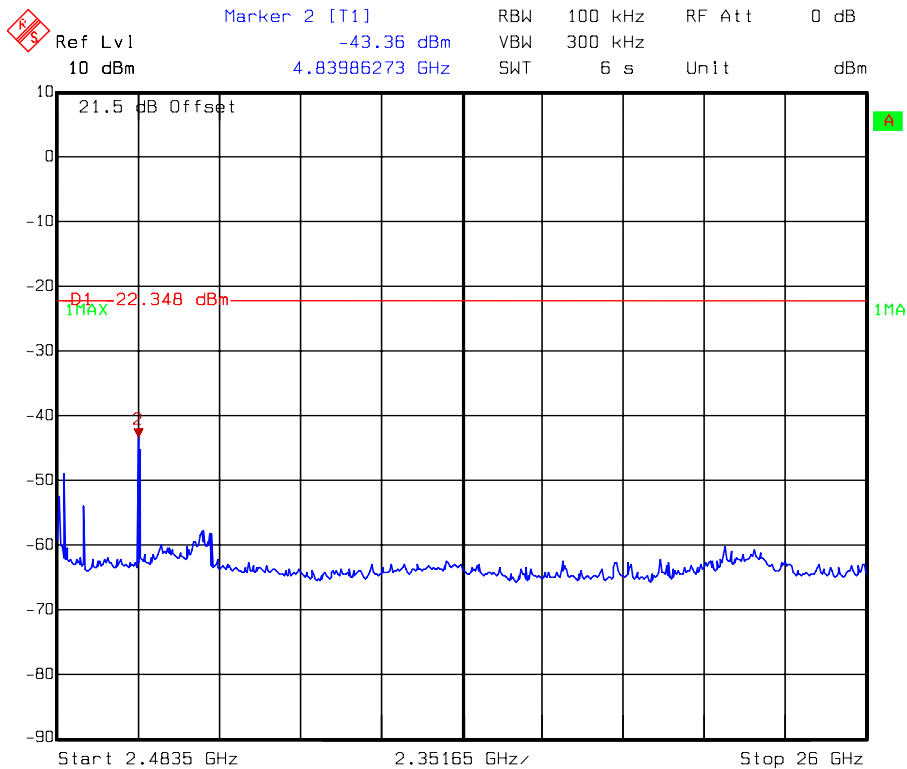

Conducted spurious @ 802.11b mode Channel 11 (1 of 3)

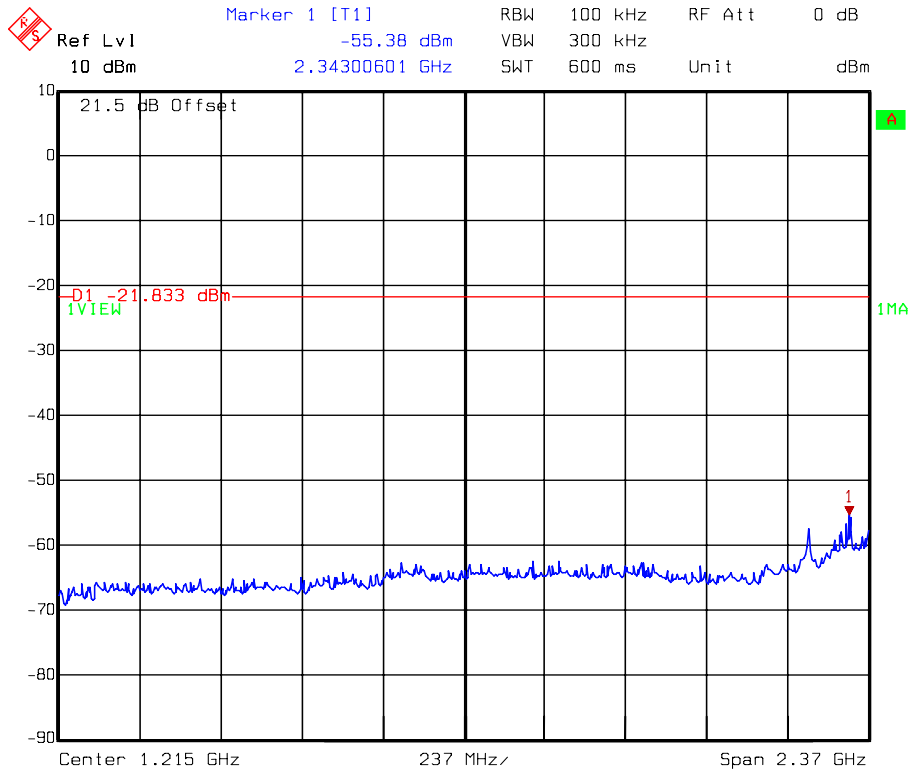

Conducted spurious @ 802.11b mode Channel 11 (2 of 3)

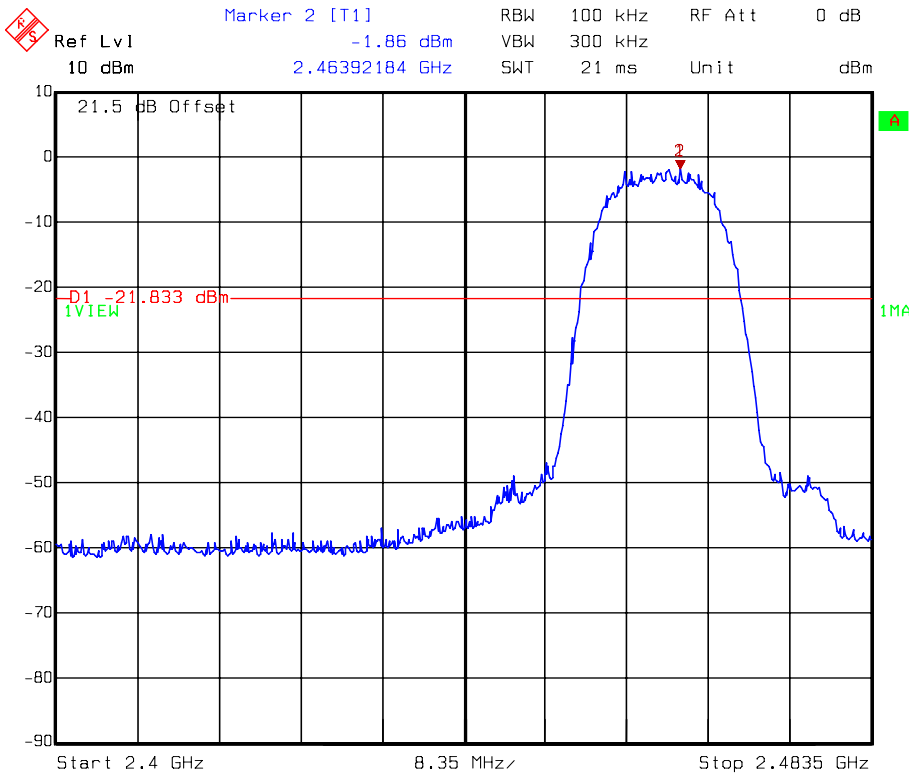

Conducted spurious @ 802.11b mode Channel 11 (3 of 3)

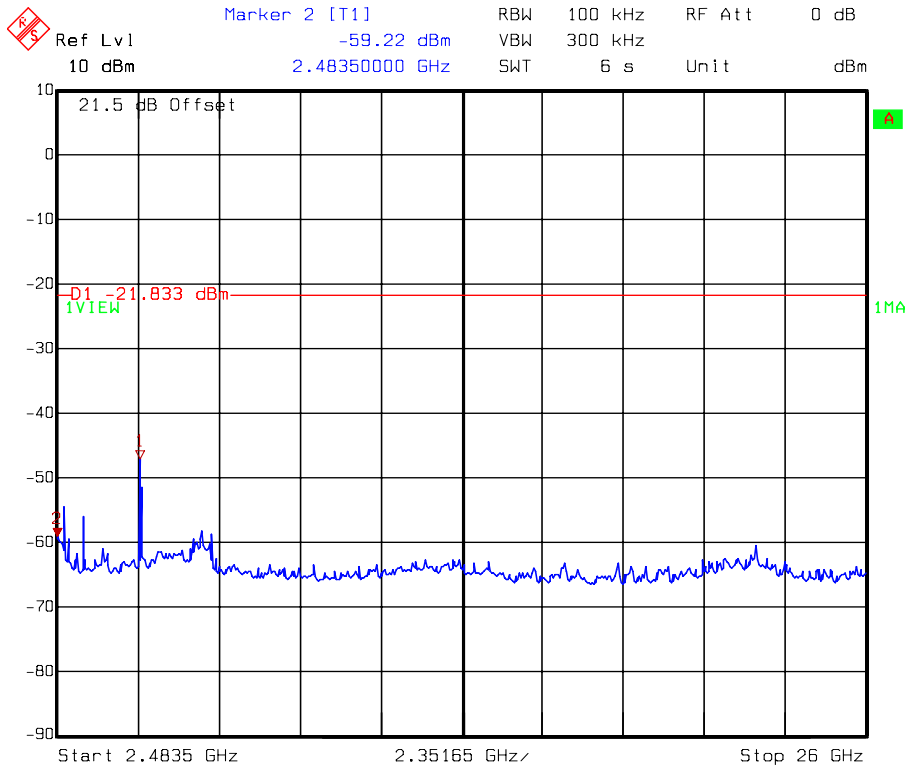

Conducted spurious @ 802.11g mode Channel 1 (1 of 3)

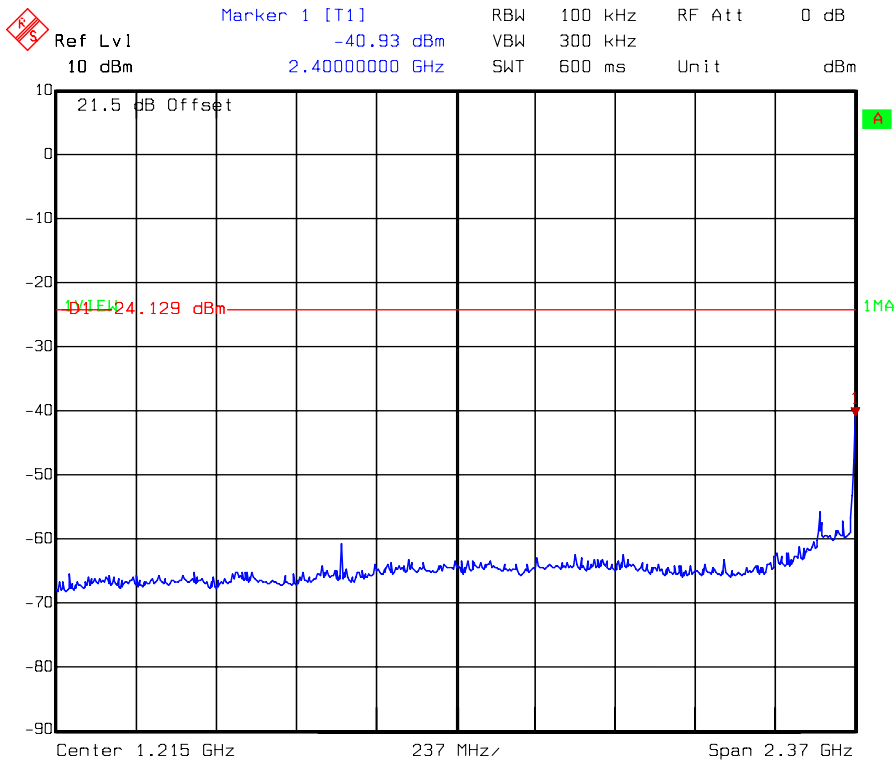

Conducted spurious @ 802.11g mode Channel 1 (2 of 3)

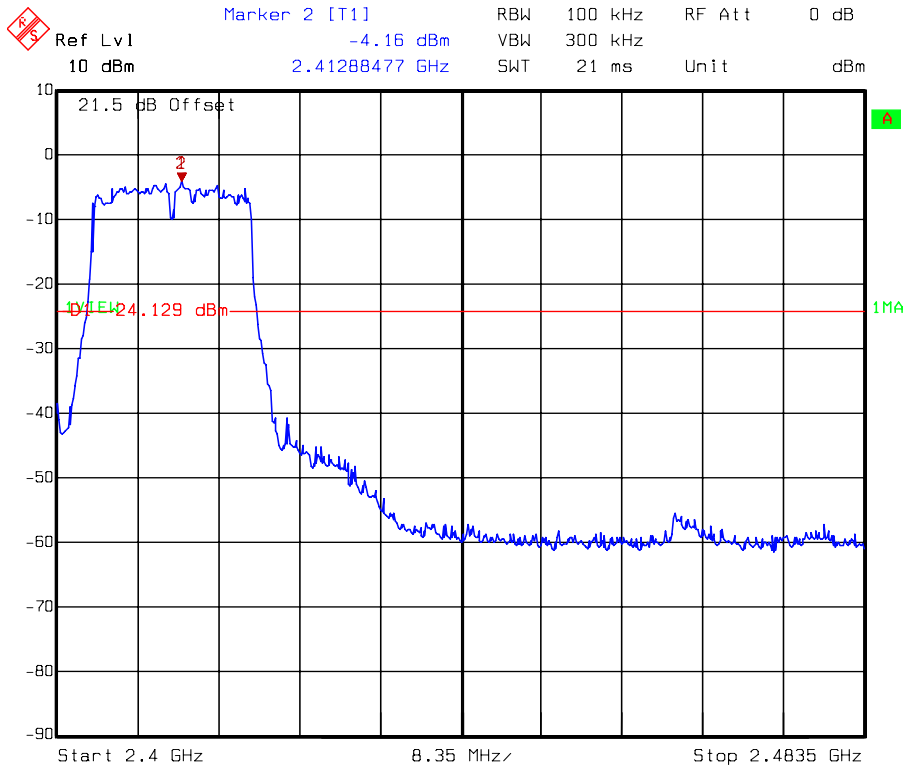

Conducted spurious @ 802.11g mode Channel 1 (3 of 3)

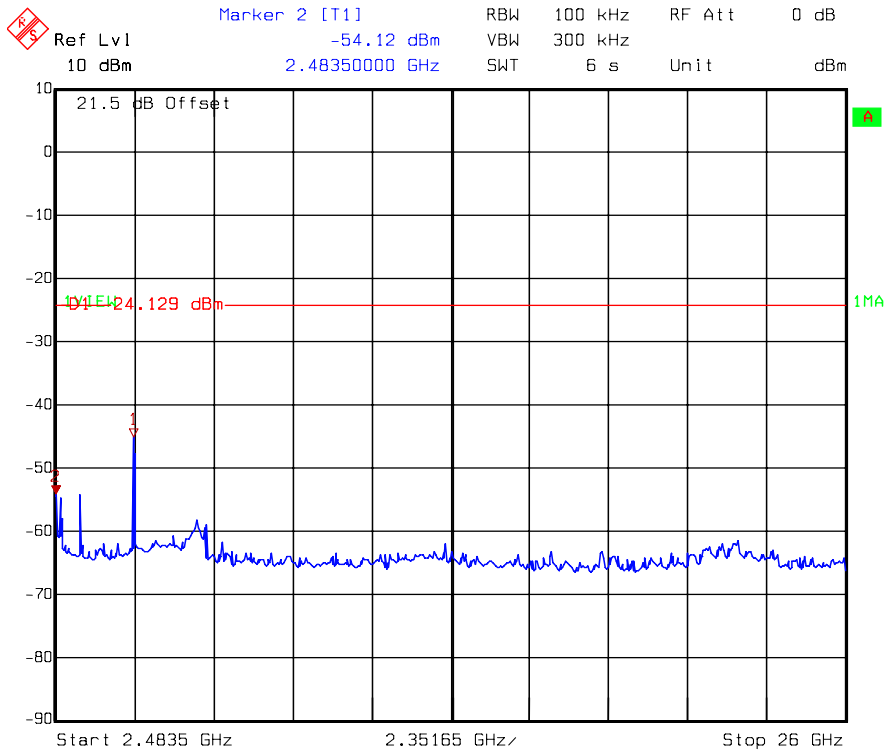

Conducted spurious @ 802.11g mode Channel 6 (1 of 3)

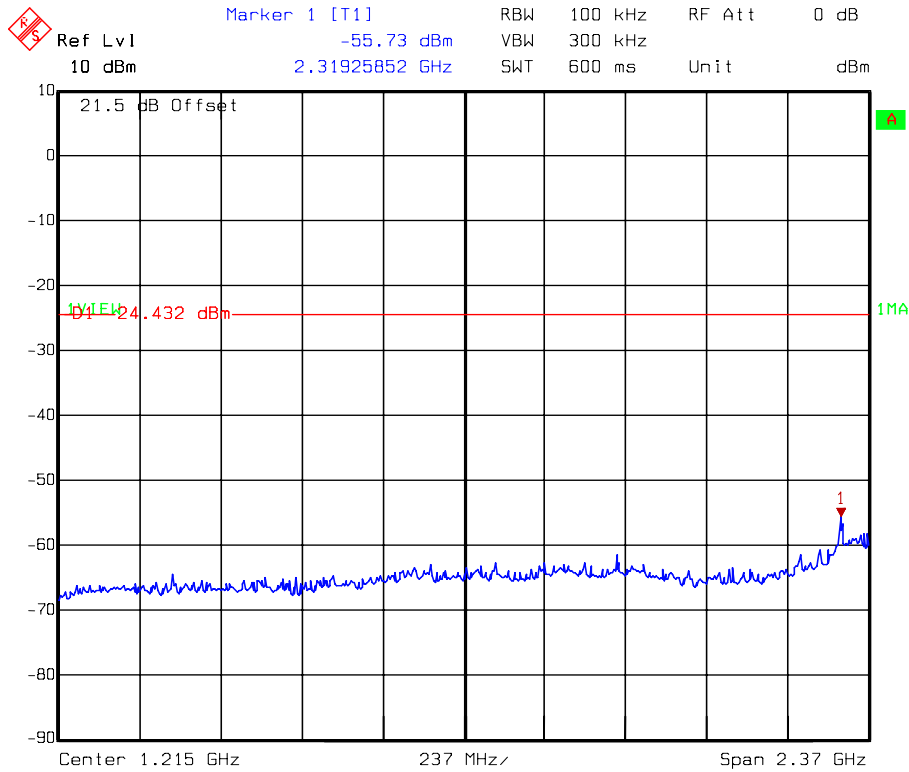

Conducted spurious @ 802.11g mode Channel 6 (2 of 3)

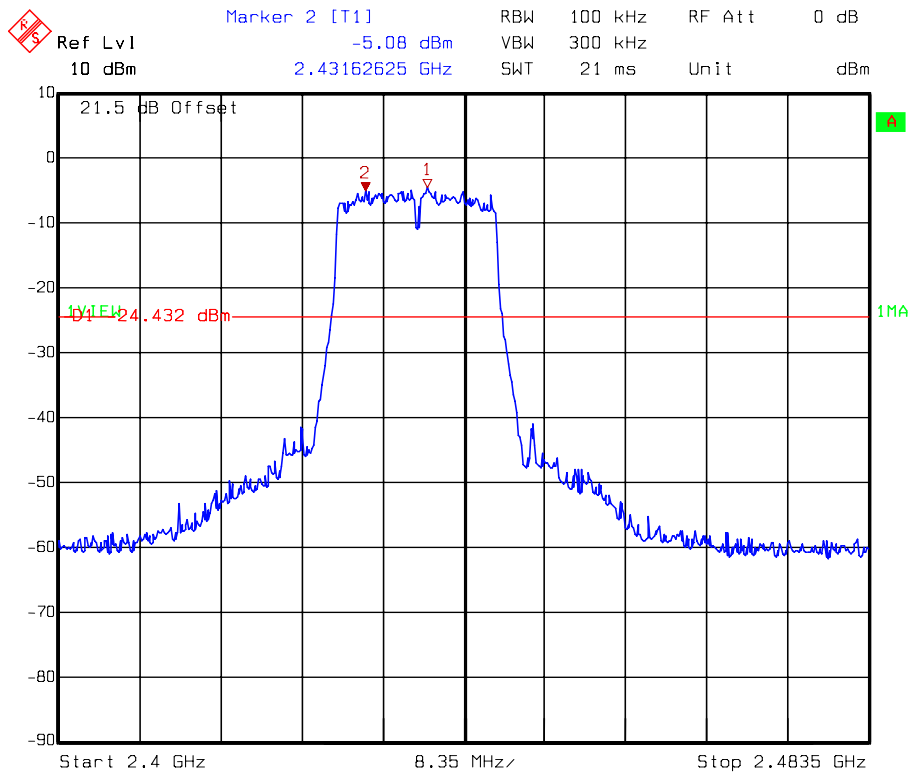

Conducted spurious @ 802.11g mode Channel 6 (3 of 3)

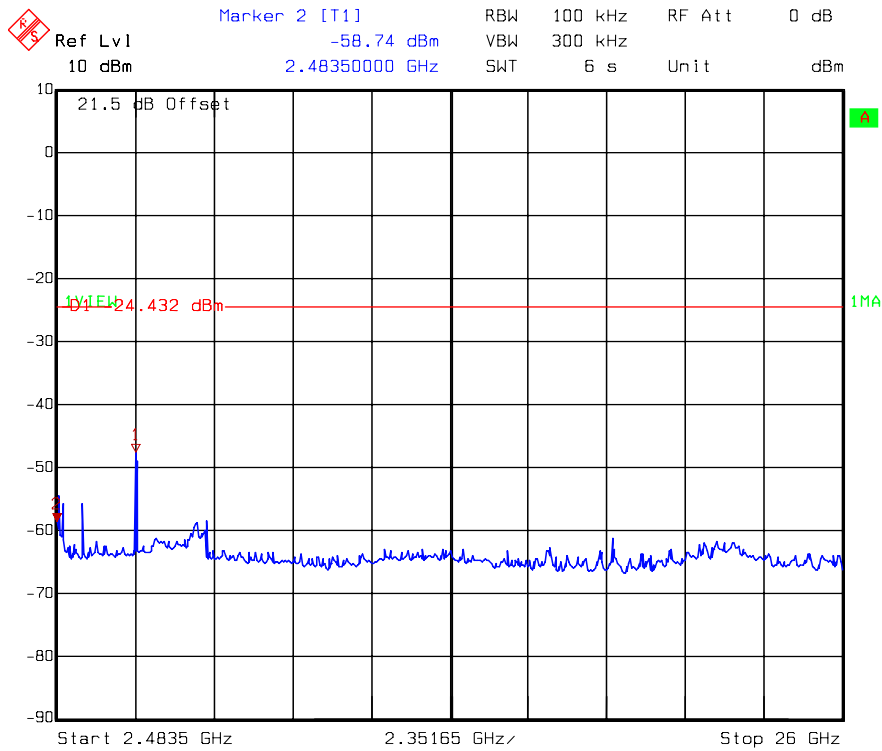

Conducted spurious @ 802.11g mode Channel 11 (1 of 3)

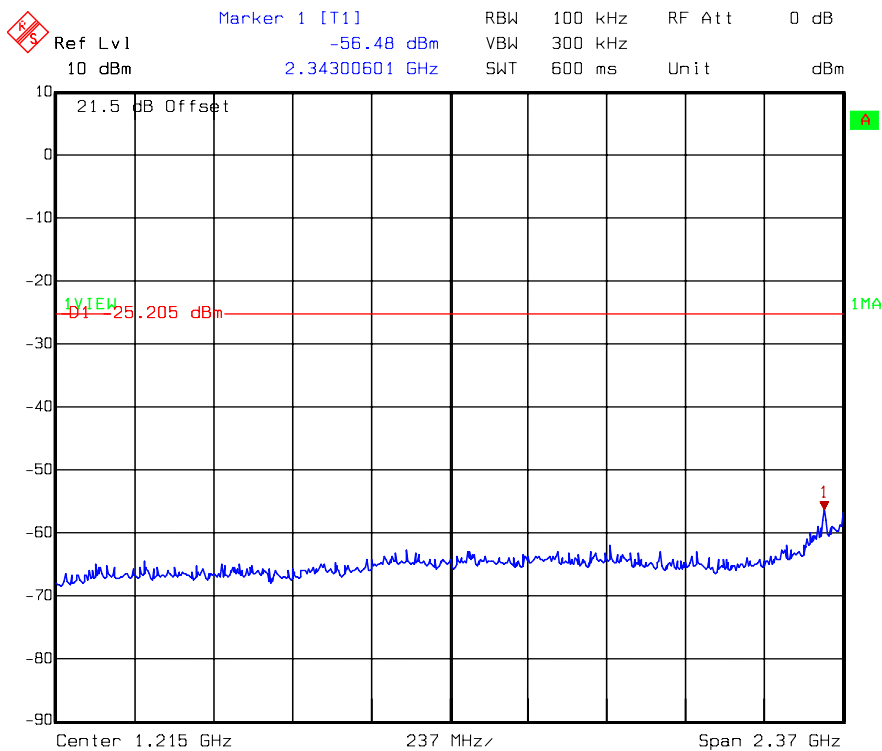

Conducted spurious @ 802.11g mode Channel 11 (2 of 3)

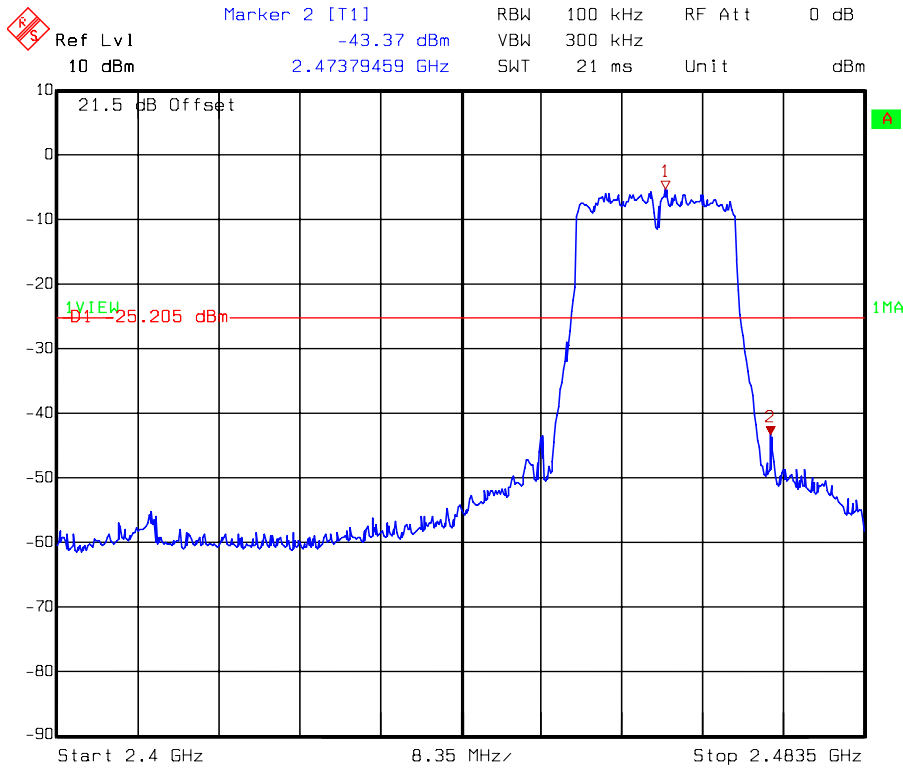

Conducted spurious @ 802.11g mode Channel 11 (3 of 3)

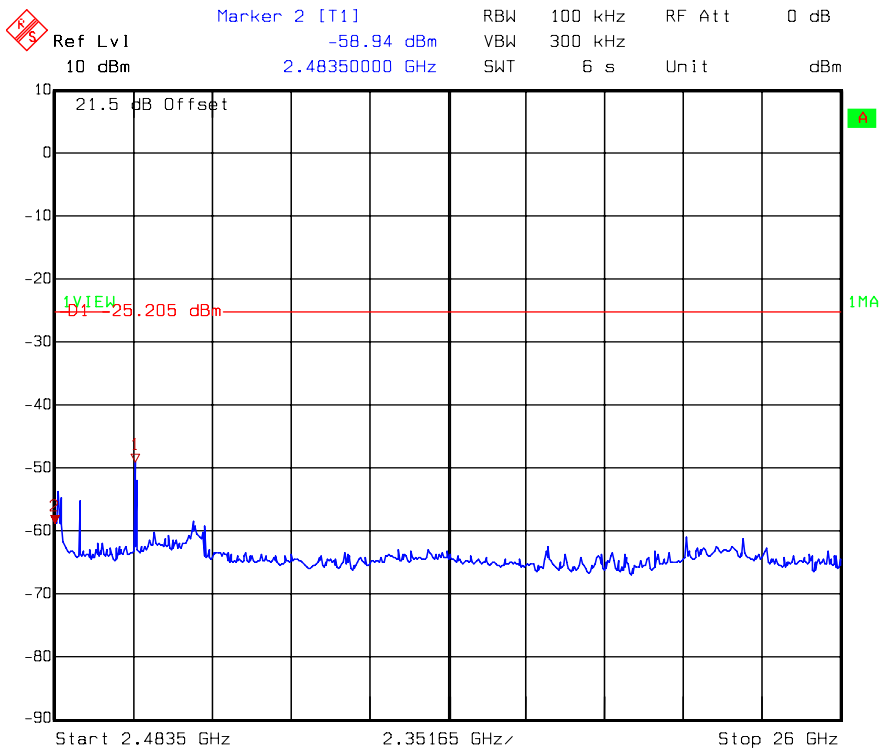

Conducted spurious @ 802.11n HT20 mode Channel 1 (1 of 3)

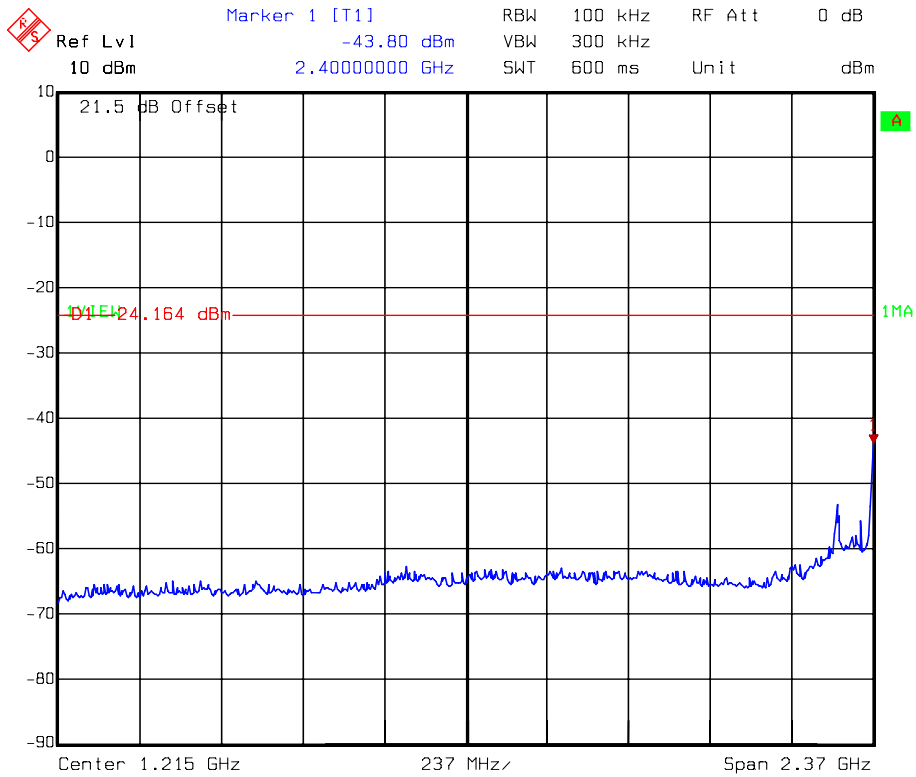

Conducted spurious @ 802.11n HT20 mode Channel 1 (2 of 3)

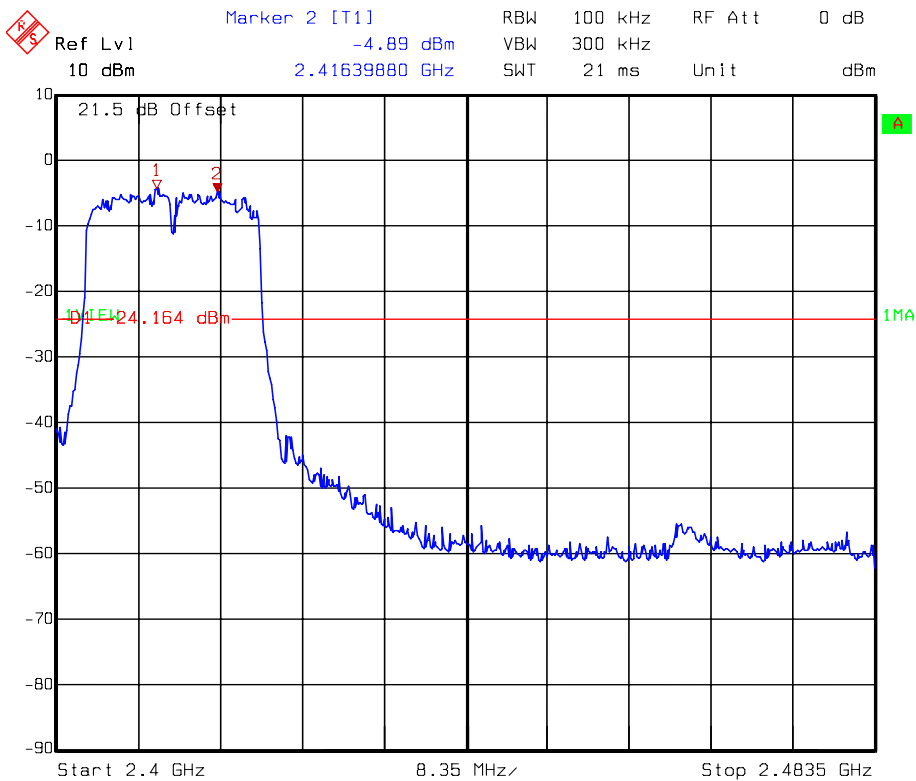

Conducted spurious @ 802.11n HT20 mode Channel 1 (3 of 3)

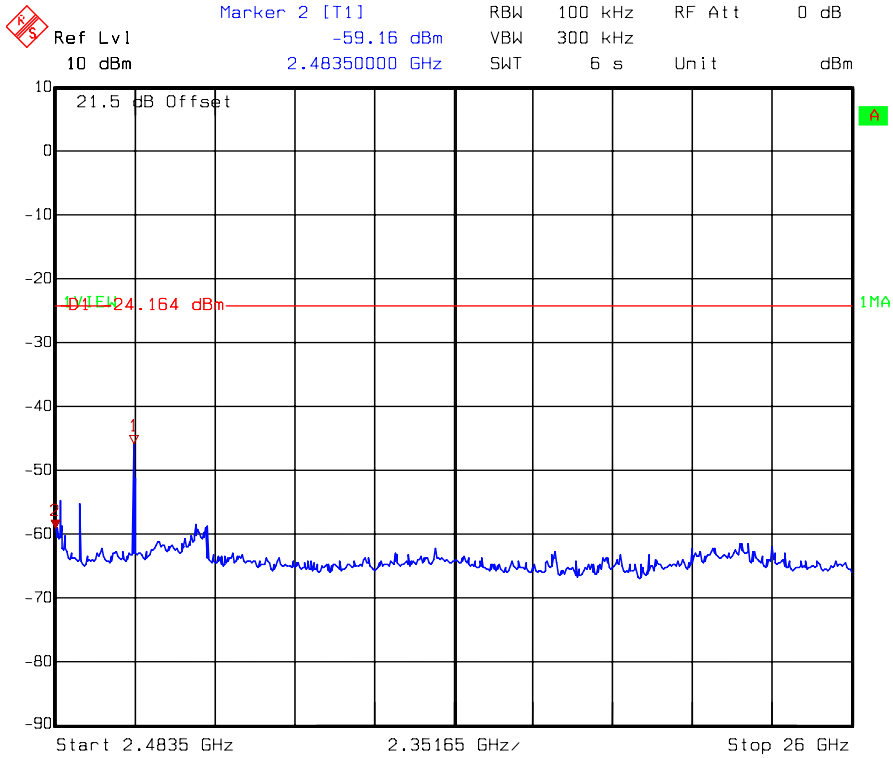

Conducted spurious @ 802.11n HT20 mode Channel 6 (1 of 3)

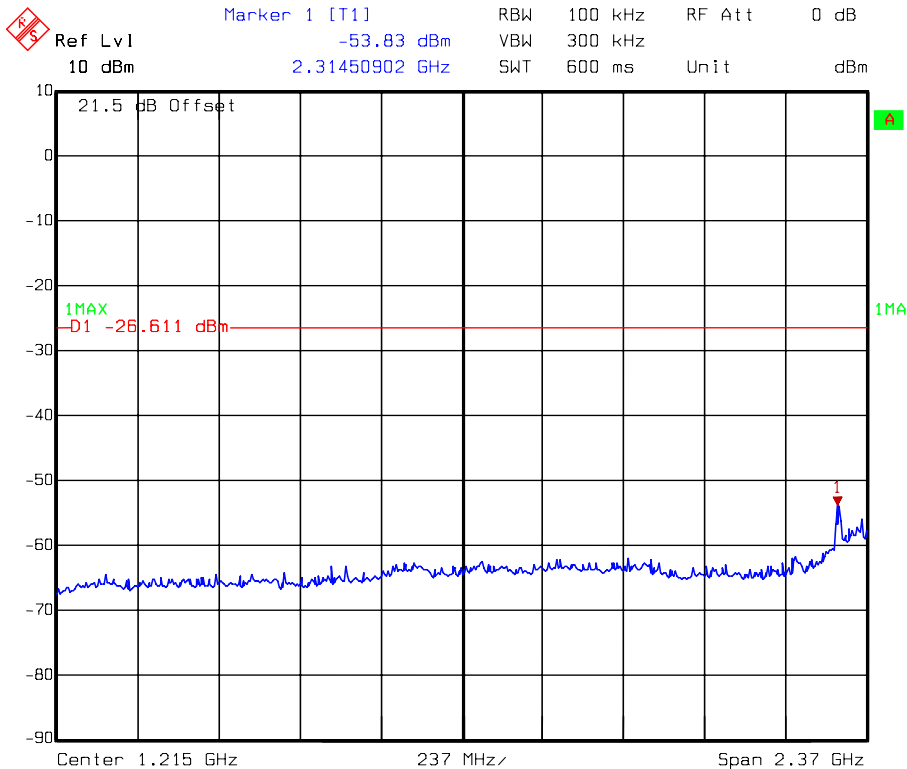

Conducted spurious @ 802.11n HT20 mode Channel 6 (2 of 3)

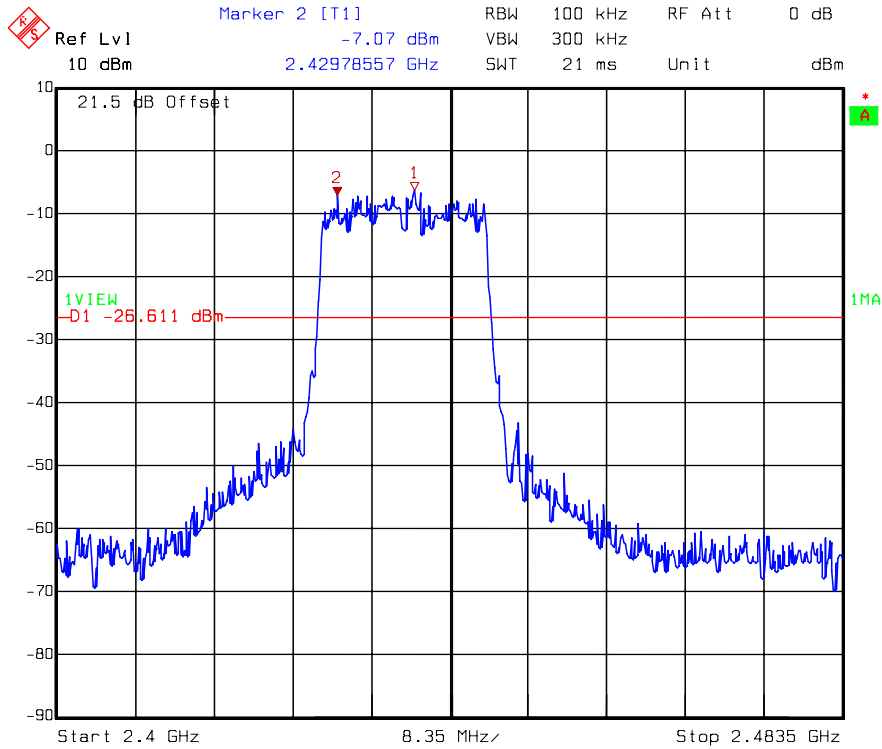

Conducted spurious @ 802.11n HT20 mode Channel 6 (3 of 3)

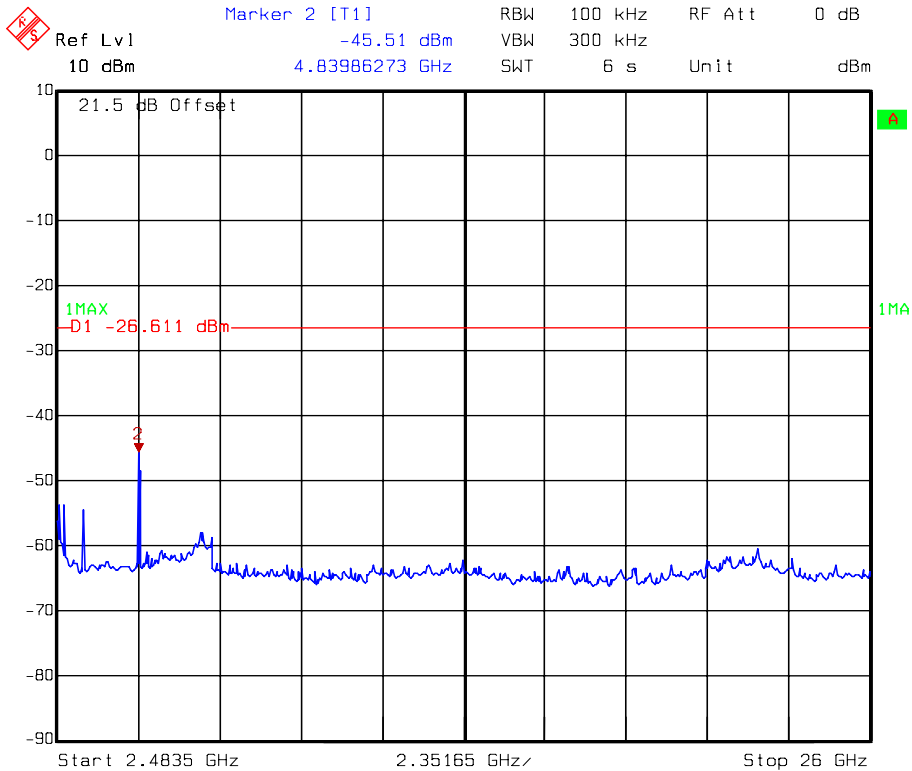

Conducted spurious @ 802.11n HT20 mode Channel 11 (1 of 3)

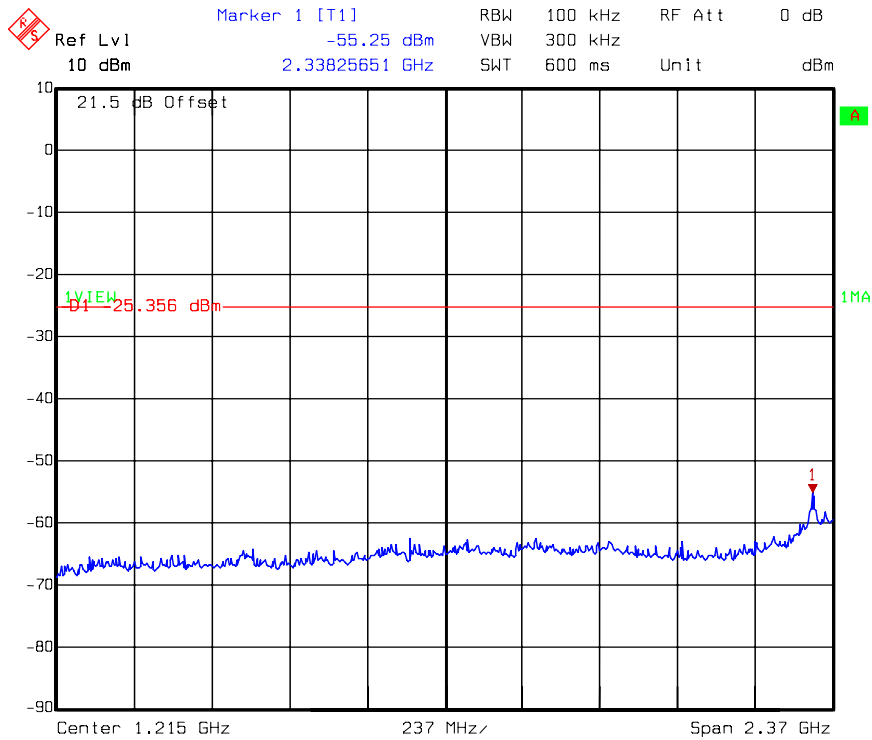

Title: Conducted Spurious (Tranpo , TTD-VM110)

Conducted spurious @ 802.11n HT20 mode Channel 11 (2 of 3)

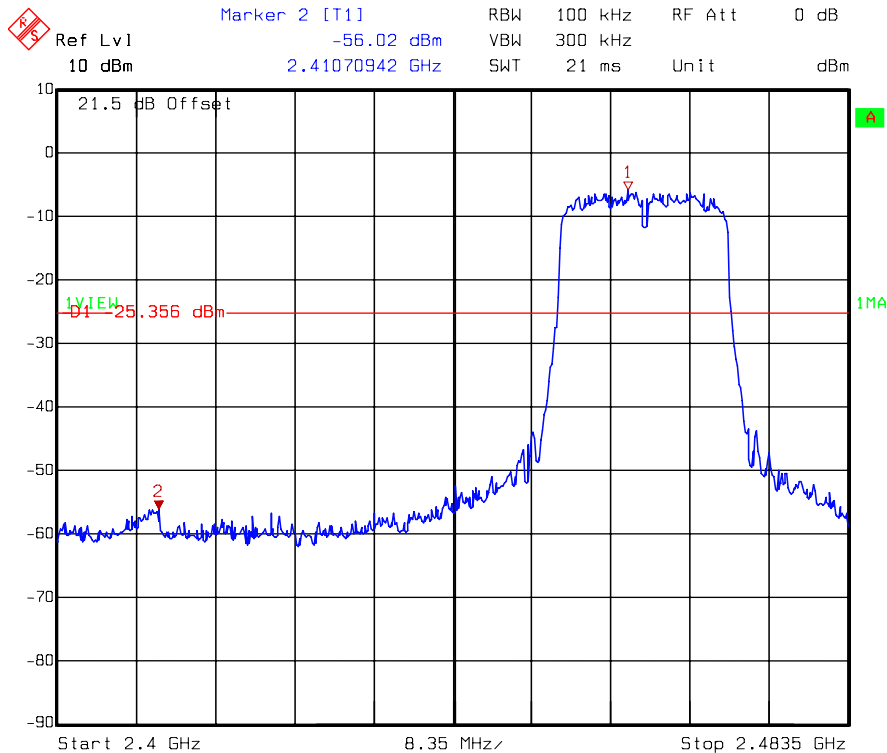

Conducted spurious @ 802.11n HT20 mode Channel 11 (3 of 3)

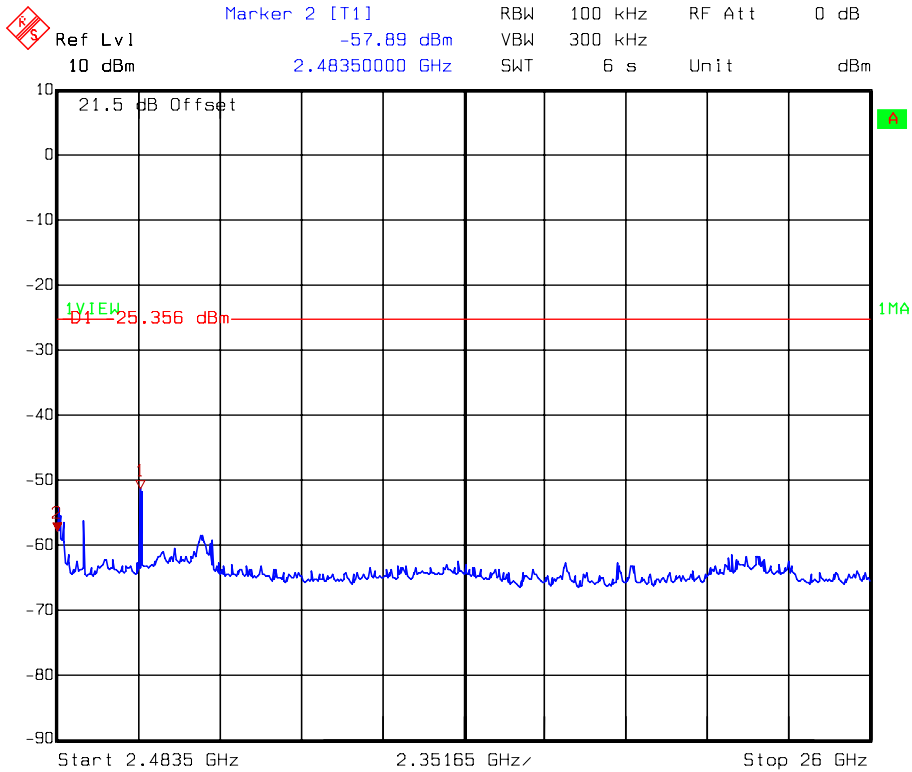

Conducted spurious @ 802.11n HT40 mode Channel 3 (1 of 3)

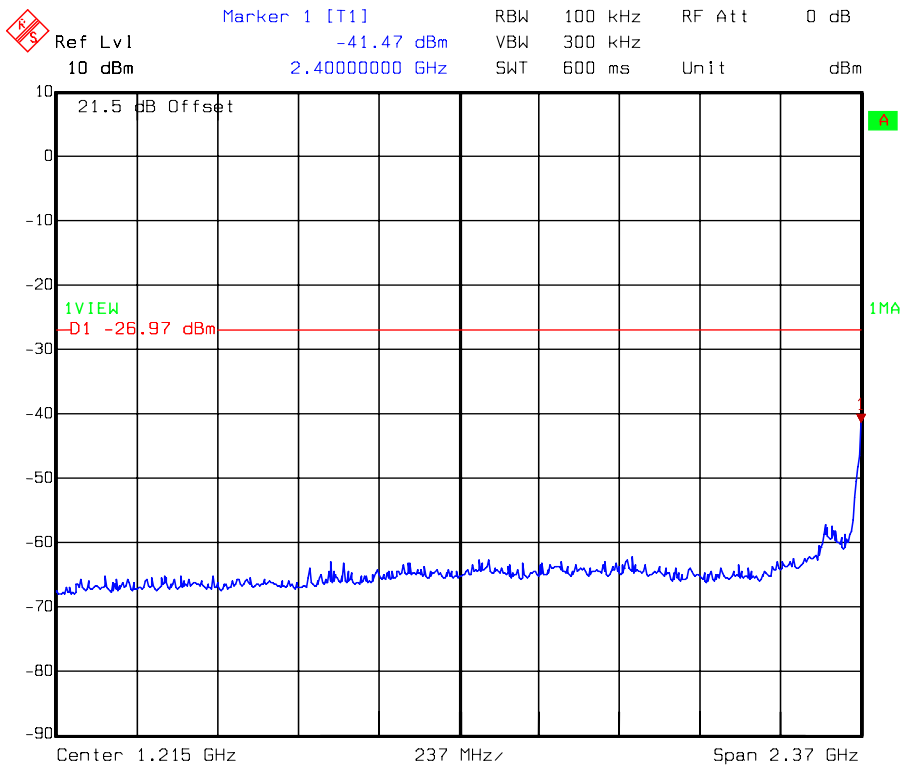

Conducted spurious @ 802.11n HT40 mode Channel 3 (2 of 3)

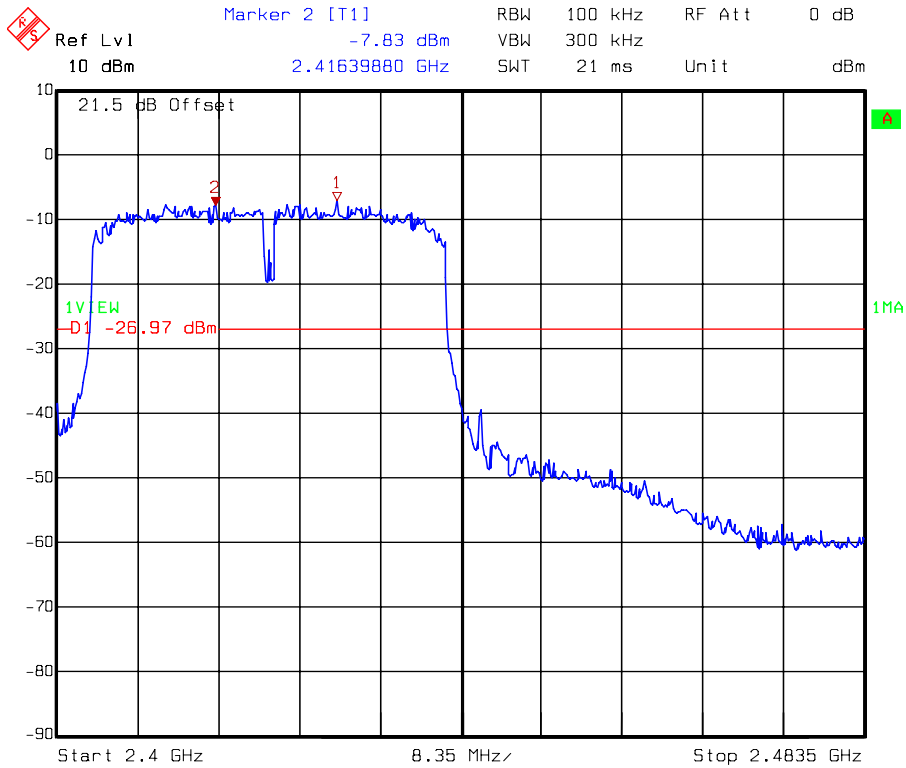

Conducted spurious @ 802.11n HT40 mode Channel 3 (3 of 3)

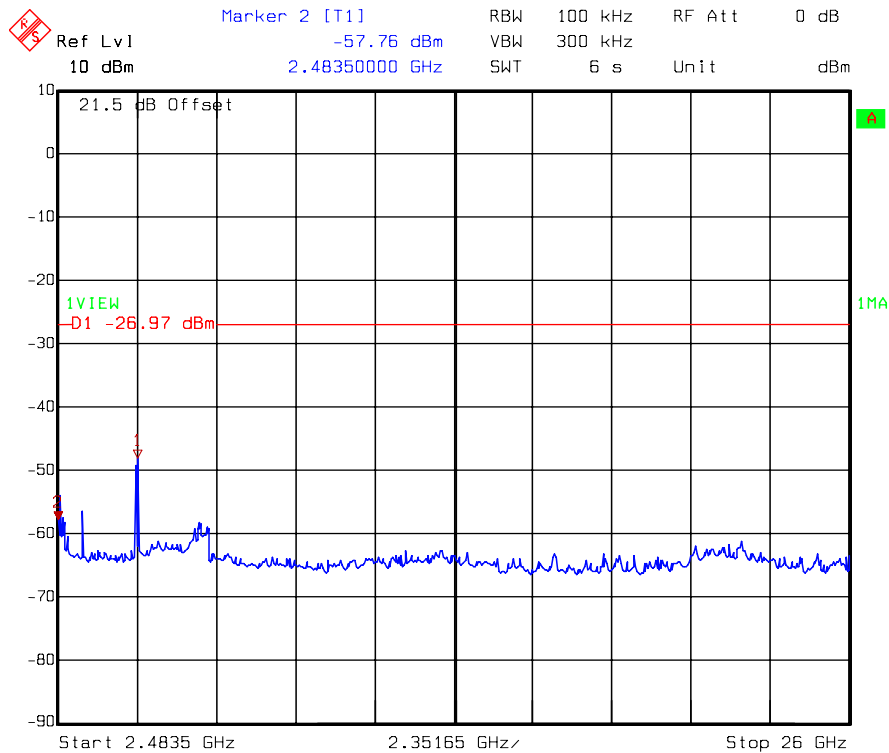

Conducted spurious @ 802.11n HT40 mode Channel 6 (1 of 3)

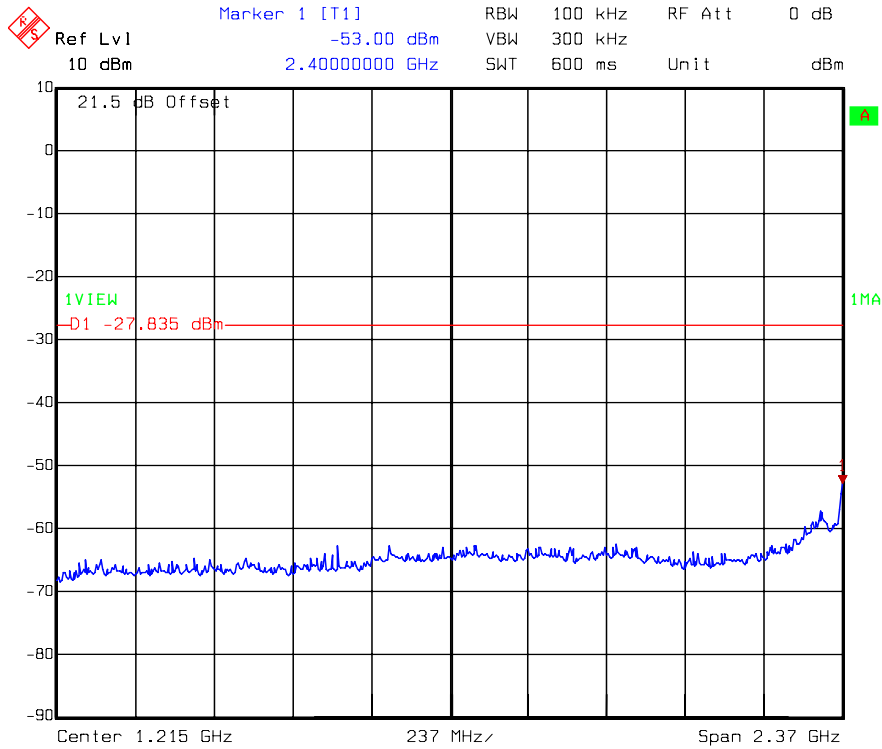

Conducted spurious @ 802.11n HT40 mode Channel 6 (2 of 3)

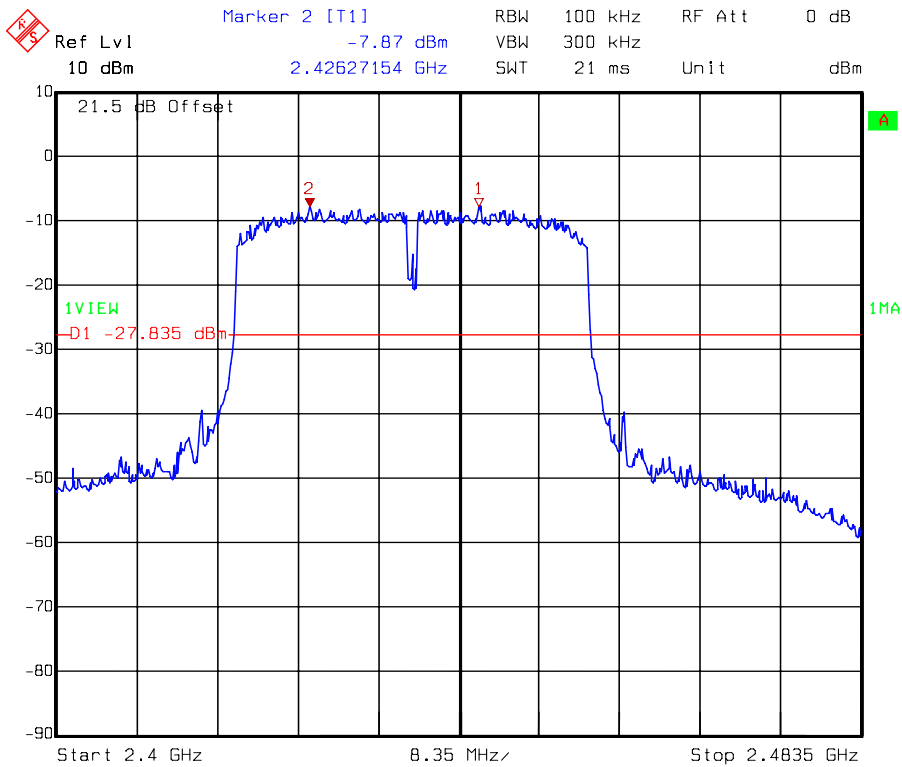

Conducted spurious @ 802.11n HT40 mode Channel 6 (3 of 3)

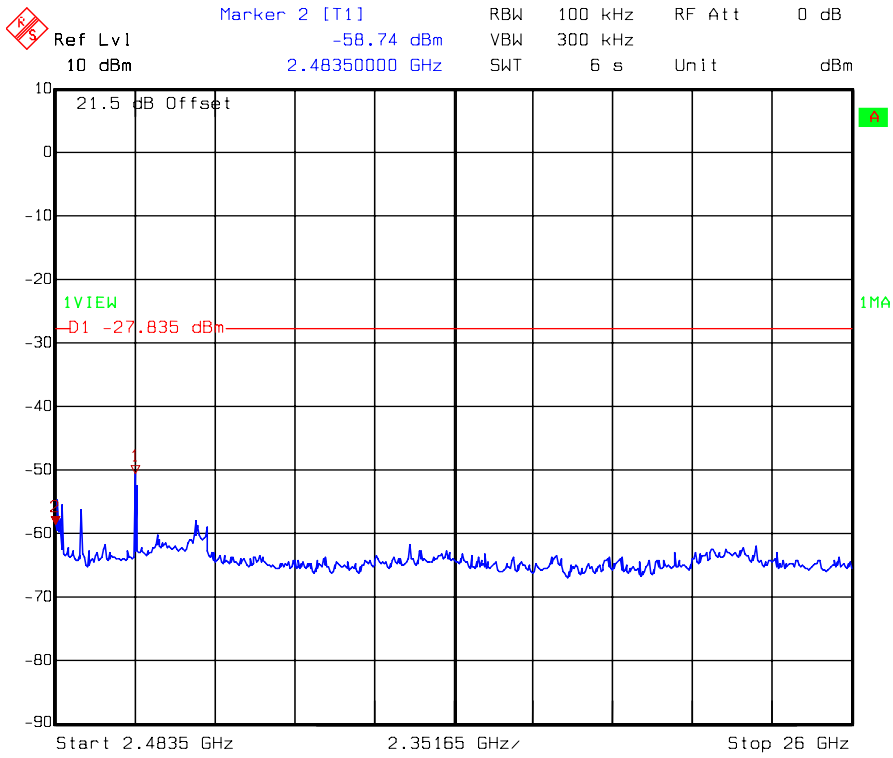

Conducted spurious @ 802.11n HT40 mode Channel 9 (1 of 3)

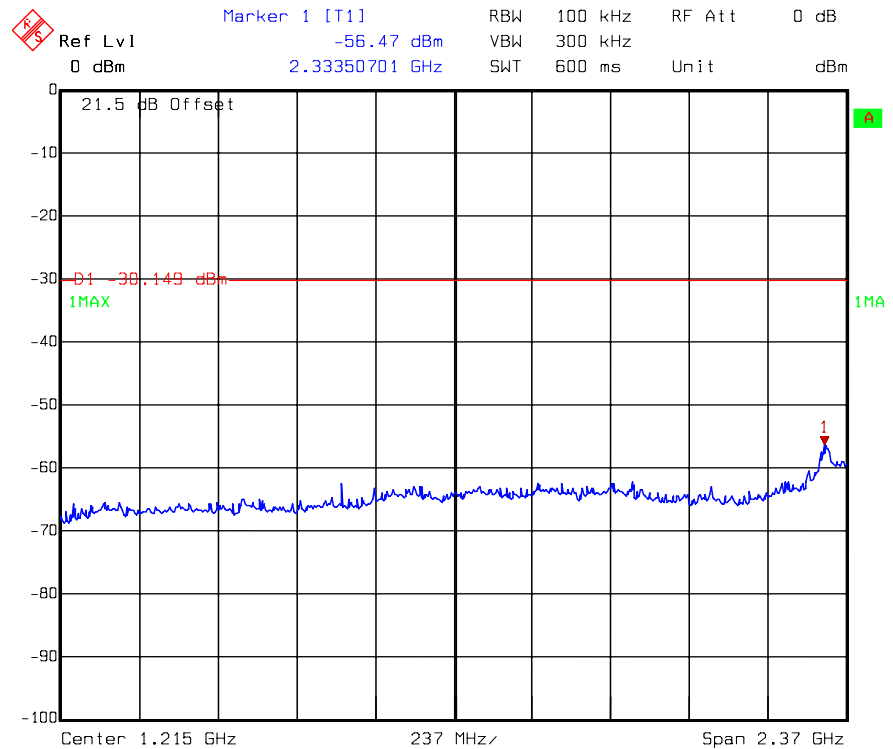

Conducted spurious @ 802.11n HT40 mode Channel 9 (2 of 3)

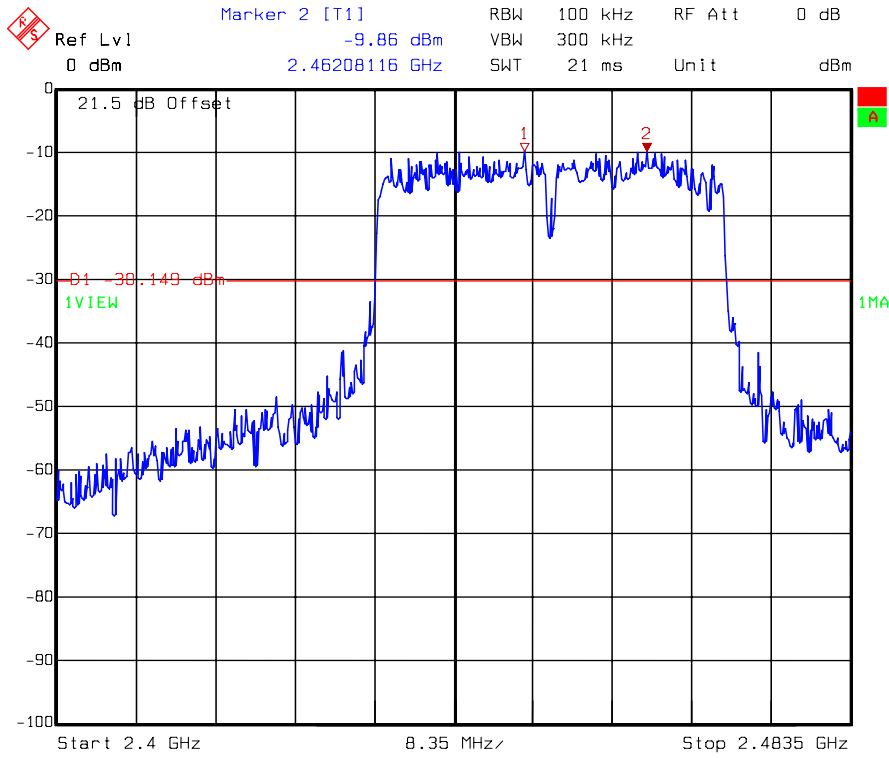

Conducted spurious @ 802.11n HT40 mode Channel 9 (3 of 3)

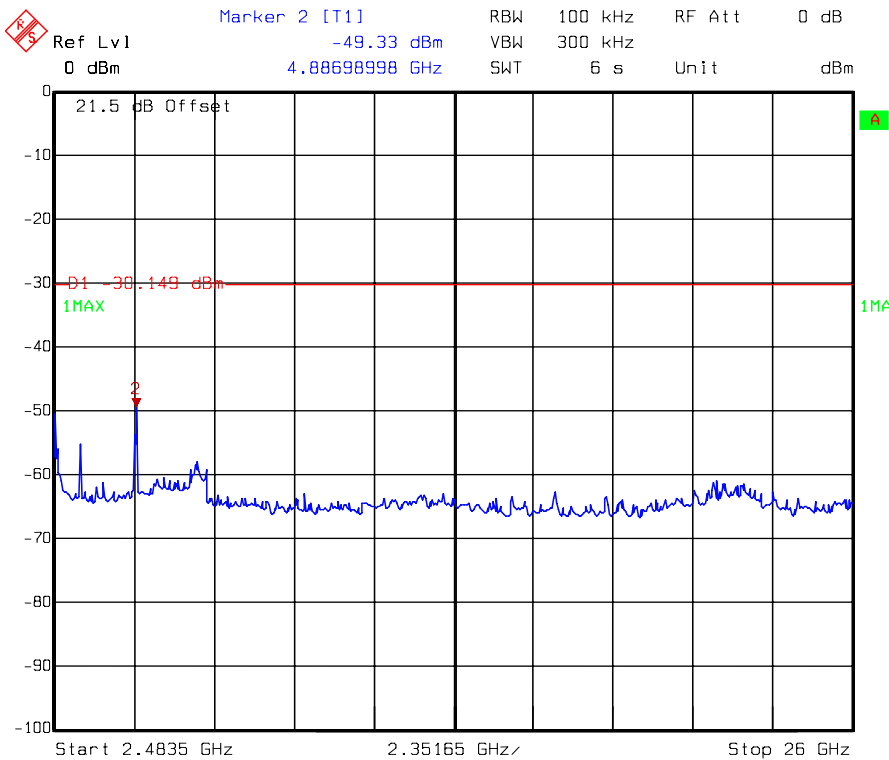

8. Radiated Spurious Emission

Name of Test	Radiated Spurious Emission
Base Standard	FCC 15.247(d), 15.209, 15.205, 15.33(a)

Test Result: Complies
Measurement Data: See Tables below
Test Date: Jun. 11, 2013~Jun. 21, 2013

Method of Measurement:

Reference FCC document: KDB558074 D01, ANSI C63.4

The signal is maximized through rotation and placement in the three orthogonal axes. According to §15.33(a), the spectrum shall be investigated from the lowest radio frequency signal generated in the device, to the tenth harmonic of the highest fundamental frequency or to 40 GHz, whichever is lower. Spectrum Analyzer Resolution Bandwidth is 100kHz or greater for frequencies 30MHz to 1GHz, 1MHz – for frequencies above 1GHz.

The EUT for testing is arranged on a wooden turntable. If some peripherals apply to the EUT, the peripherals will be connected to EUT and the whole system. During the test, all cables were arranged to produce worst-case emissions. The signal is maximized through rotation. The height of antenna and polarization is changing constantly for exploring for maximum signal level. The height of antenna can be up to 4 meters and down to 1 meter. The measurement for radiated emission will be done at the distance of three meters unless the signal level is too low to measure at that distance. In the case of the reading under noise floor, a pre-amplifier is used and/or the test is conducted at a closer distance. And then all readings are extrapolated back to the equivalent 3 meters reading using inverse scaling with distance. The EUT configuration refers to the “Spurious set-up photo.pdf”.

Test Diagram:

Radiated emission from 9kHz to 30MHz uses Loop Antenna:

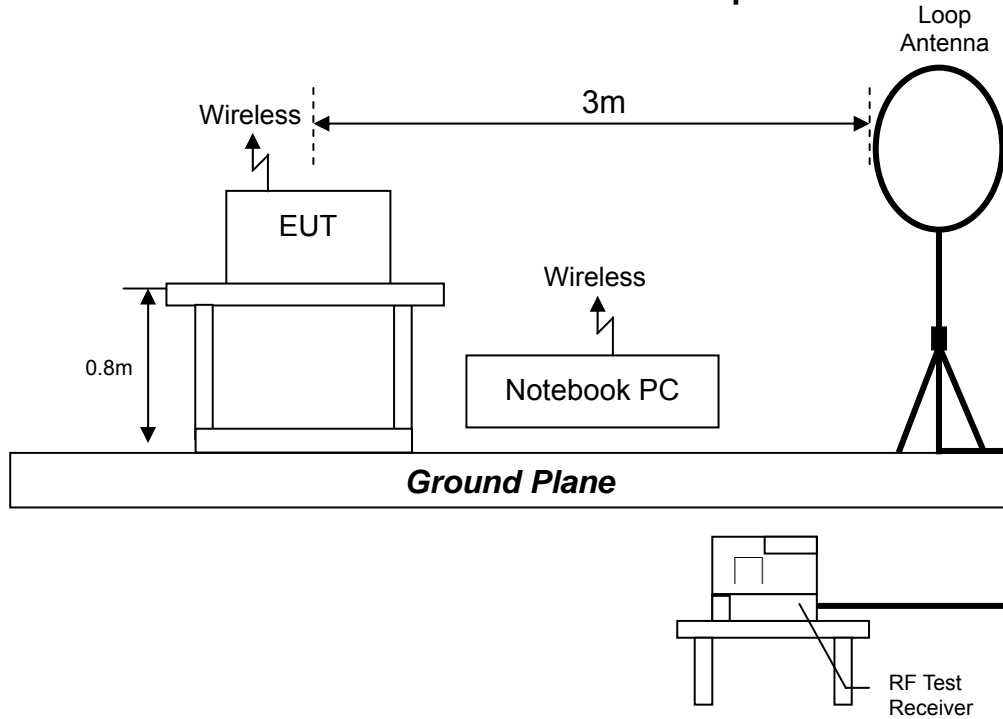

Radiated emission from 30MHz to 1GHz uses Bilog Antenna:

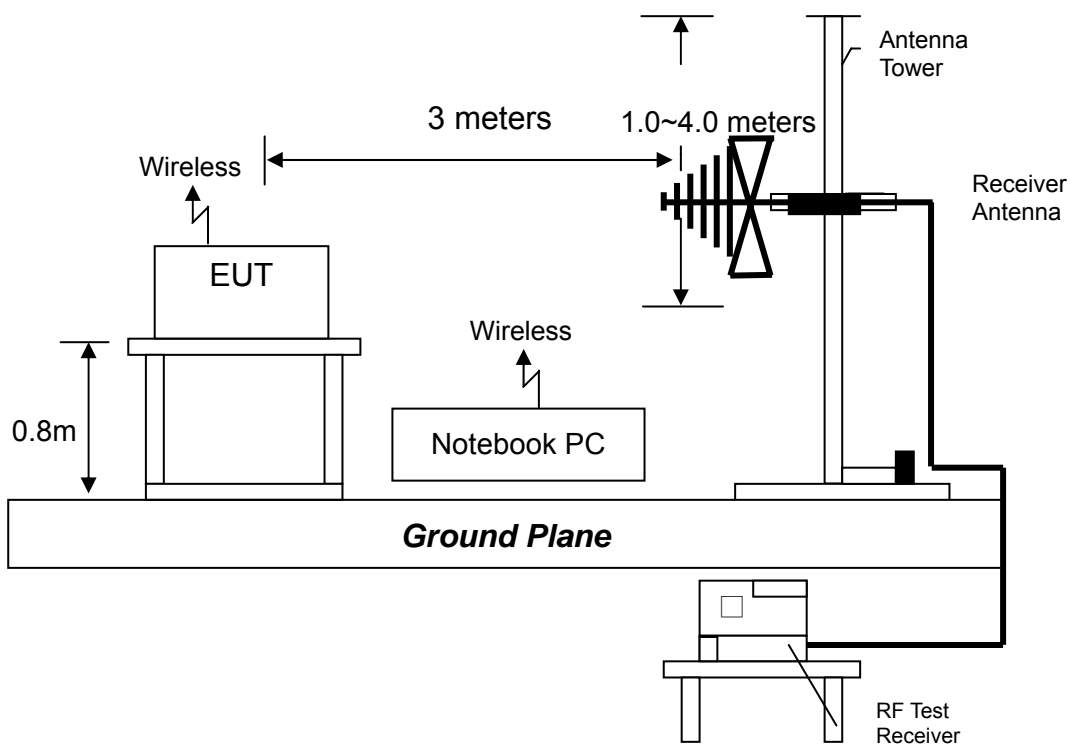

Radiated emission above 1GHz uses Horn Antenna:

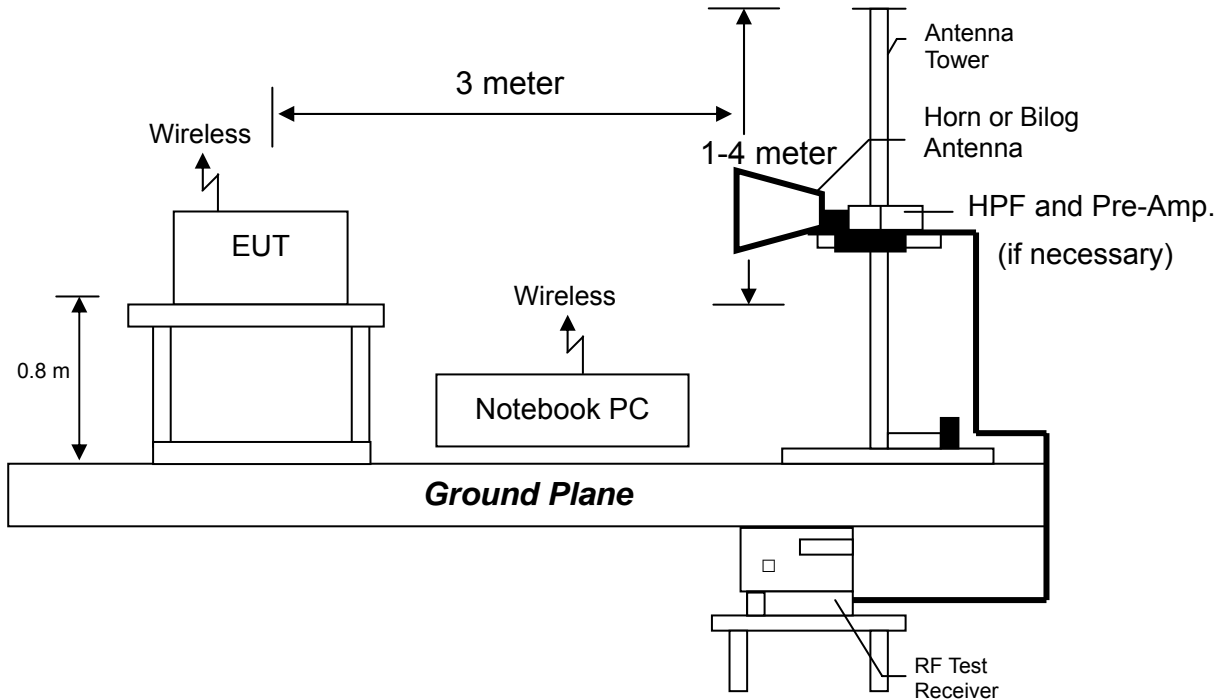

Emission Limit:

The spurious Emission shall test through the 10th harmonic. In addition, radiated emissions which fall in the restricted bands, as defined in §15.205(a), must also comply with the radiated emission limits specified in §15.209(a).

Frequency (MHz)	Field Strength (microvolts/meter)
0.009~0.490	2400/F(kHz)
0.490~1.705	2400/F(kHz)
1.705~30	30
30-88	100
88-216	150
216-960	200
Above 960	500

Remark:

1. In the above table, the tighter limit applies at the band edges.
2. Distance refers to the distance in meters between the measuring instrument antenna and the closed point of any part of the device or system

- Note:**
- (1) The EUT was tested while in a continuous transmit mode and the worst case data rates are 1 Mbps data rate for 802.11b mode, 6 Mbps data rate for 802.11g mode, 6.5 Mbps data rate for 802.11n HT20 mode and 13.5 Mbps data rate for 802.11n HT40 mode. The EUT was tuned to a low, middle and high channel.
 - (2) The EUT operating at 2.4 GHz ISM band. Frequency Range scanned from 12 MHz to 25 GHz.

Measurement results: frequencies equal to or less than 1 GHz

The test was performed on EUT under 802.11b, 802.11g, 802.11n HT20 and 802.11n HT40 continuously transmitting mode. The worst case occurred at 802.11b Tx Channel 11.

EUT : TTD-VMi110
Worst Case : 802.11b Tx at Channel 11

Antenna Polariz. (V/H)	Freq. (MHz)	Receiver Detector	Corr. Factor (dB/m)	Reading (dBuV)	Corrected Level (dBuV/m)	Limit @ 3 m (dBuV/m)	Margin (dB)
V	142.52	QP	14.27	20.07	34.34	43.50	-9.16
V	359.80	QP	15.06	24.27	39.33	46.00	-6.67
V	499.48	QP	18.43	20.51	38.93	46.00	-7.07
V	538.28	QP	19.46	20.05	39.51	46.00	-6.49
V	600.36	QP	20.75	22.06	42.81	46.00	-3.19
V	840.92	QP	23.62	14.03	37.65	46.00	-8.35
H	161.92	QP	13.84	22.01	35.84	43.50	-7.66
H	227.88	QP	11.63	26.72	38.34	46.00	-7.66
H	359.80	QP	15.48	28.70	44.17	46.00	-1.83
H	419.94	QP	16.81	19.13	35.94	46.00	-10.06
H	600.36	QP	20.88	17.09	37.96	46.00	-8.04
H	840.92	QP	24.04	18.84	42.87	46.00	-3.13

Remark: 1. Corr. Factor = Antenna Factor + Cable Loss
2. Corrected Level = Reading + Corr. Factor

Note: The amplitude of spurious emissions that are attenuated by more than 20dB below the permissible value has no need to be reported.

Measurement results: frequency above 1GHz

EUT : TTD-VMi110
Test Condition : 802.11b Tx at Channel 1

Frequency (MHz)	Spectrum Analyzer Detector	Antenna Polariz. (H/V)	Preamp. Gain (dB)	Correction Factor (dB/m)	Reading (dBuV)	Corrected Level (dBuV/m)	Limit @ 3 m (dBuV/m)	Margin (dB)
4824	PK	V	35.1	38.54	59.99	63.43	74	-10.57
4824	AV	V	35.1	38.54	49.73	53.17	54	-0.83
4824	PK	H	35.1	38.54	47.17	50.61	54	-3.39

Remark:

1. Correction Factor = Antenna Factor + Cable Loss
2. Corrected Level = Reading + Correction Factor – Preamp. Gain
3. The frequency measured ranges from 1 GHz to 25 GHz. The data value listed above which is higher than the system noise floor.

EUT : TTD-VMi110
Test Condition : 802.11b Tx at Channel 6

Frequency (MHz)	Spectrum Analyzer Detector	Antenna Polariz. (H/V)	Preamp. Gain (dB)	Correction Factor (dB/m)	Reading (dBuV)	Corrected Level (dBuV/m)	Limit @ 3 m (dBuV/m)	Margin (dB)
4874	PK	V	35.1	38.54	62.79	66.23	74	-7.77
4874	AV	V	35.1	38.54	49.99	53.43	54	-0.57
4874	PK	H	35.1	38.54	49.76	53.20	54	-0.80

Remark:

1. Correction Factor = Antenna Factor + Cable Loss
2. Corrected Level = Reading + Correction Factor – Preamp. Gain
3. The frequency measured ranges from 1 GHz to 25 GHz. The data value listed above which is higher than the system noise floor.

EUT : TTD-VMi110
Test Condition : 802.11b Tx at Channel 11

Frequency (MHz)	Spectrum Analyzer Detector	Antenna Polariz. (H/V)	Preamp. Gain (dB)	Correction Factor (dB/m)	Reading (dBuV)	Corrected Level (dBuV/m)	Limit @ 3 m (dBuV/m)	Margin (dB)
4924	PK	V	35.1	38.54	59.16	62.60	74	-11.40
4924	AV	V	35.1	38.54	49.73	53.17	54	-0.83
4924	PK	H	35.1	38.54	45.3	48.74	54	-5.26

Remark:

1. Correction Factor = Antenna Factor + Cable Loss
2. Corrected Level = Reading + Correction Factor – Preamp. Gain
3. The frequency measured ranges from 1GHz to 25GHz. The data value listed above which is higher than the system noise floor.

EUT : TTD-VMi110
Test Condition : 802.11g Tx at Channel 1

Frequency (MHz)	Spectrum Analyzer Detector	Antenna Polariz. (H/V)	Preamp. Gain (dB)	Correction Factor (dB/m)	Reading (dBuV)	Corrected Level (dBuV/m)	Limit @ 3 m (dBuV/m)	Margin (dB)
4824	PK	V	35.1	38.54	60.69	64.13	74	-9.87
4824	AV	V	35.1	38.54	49.39	52.83	54	-1.17
4824	PK	H	35.1	38.54	51.27	54.71	74	-19.29
4824	AV	H	35.1	38.54	44.81	48.25	54	-5.75

Remark:

1. Correction Factor = Antenna Factor + Cable Loss
2. Corrected Level = Reading + Correction Factor – Preamp. Gain
3. The frequency measured ranges from 1 GHz to 25 GHz. The data value listed above which is higher than the system noise floor.

EUT : TTD-VMi110
Test Condition : 802.11g Tx at Channel 6

Frequency (MHz)	Spectrum Analyzer Detector	Antenna Polariz. (H/V)	Preamp. Gain (dB)	Correction Factor (dB/m)	Reading (dBuV)	Corrected Level (dBuV/m)	Limit @ 3 m (dBuV/m)	Margin (dB)
4874	PK	V	35.1	38.54	57.72	61.16	74	-12.84
4874	AV	V	35.1	38.54	48.21	51.65	54	-2.35
4874	PK	H	35.1	38.54	47.32	50.76	54	-3.24

Remark:

1. Correction Factor = Antenna Factor + Cable Loss
2. Corrected Level = Reading + Correction Factor – Preamp. Gain
3. The frequency measured ranges from 1 GHz to 25 GHz. The data value listed above which is higher than the system noise floor.

EUT : TTD-VMi110
Test Condition : 802.11g Tx at Channel 11

Frequency (MHz)	Spectrum Analyzer Detector	Antenna Polariz. (H/V)	Preamp. Gain (dB)	Correction Factor (dB/m)	Reading (dBuV)	Corrected Level (dBuV/m)	Limit @ 3 m (dBuV/m)	Margin (dB)
4924	PK	V	35.1	38.54	54.44	57.88	74	-16.12
4924	AV	V	35.1	38.54	45.87	49.31	54	-4.69
4924	PK	H	35.1	38.54	42.27	45.71	54	-8.29

Remark:

1. Correction Factor = Antenna Factor + Cable Loss
2. Corrected Level = Reading + Correction Factor – Preamp. Gain
3. The frequency measured ranges from 1 GHz to 25 GHz. The data value listed above which is higher than the system noise floor.

EUT : TTD-VMi110
Test Condition : 802.11n HT20 Tx at Channel 1

Frequency (MHz)	Spectrum Analyzer Detector	Antenna Polariz. (H/V)	Preamp. Gain (dB)	Correction Factor (dB/m)	Reading (dBUV)	Corrected Level (dBUV/m)	Limit @ 3 m (dBUV/m)	Margin (dB)
4824	PK	V	35.1	38.54	55.9	59.34	74	-14.66
4824	AV	V	35.1	38.54	48.51	51.95	54	-2.05
4824	PK	H	35.1	38.54	47.13	50.57	54	-3.43

Remark:

1. Correction Factor = Antenna Factor + Cable Loss
2. Corrected Level = Reading + Correction Factor – Preamp. Gain
3. The frequency measured ranges from 1 GHz to 25 GHz. The data value listed above which is higher than the system noise floor.

EUT : TTD-VMi110
Test Condition : 802.11n HT20 Tx at Channel 6

Frequency (MHz)	Spectrum Analyzer Detector	Antenna Polariz. (H/V)	Preamp. Gain (dB)	Correction Factor (dB/m)	Reading (dBUV)	Corrected Level (dBUV/m)	Limit @ 3 m (dBUV/m)	Margin (dB)
4874	PK	V	35.1	38.54	56.96	60.40	74	-13.60
4874	AV	V	35.1	38.54	46.74	50.18	54	-3.82
4874	PK	H	35.1	38.54	46.25	49.69	54	-4.31

Remark:

1. Correction Factor = Antenna Factor + Cable Loss
2. Corrected Level = Reading + Correction Factor – Preamp. Gain
3. The frequency measured ranges from 1 GHz to 25 GHz. The data value listed above which is higher than the system noise floor.

EUT : TTD-VMi110
Test Condition : 802.11n HT20 Tx at Channel 11

Frequency (MHz)	Spectrum Analyzer Detector	Antenna Polariz. (H/V)	Preamp. Gain (dB)	Correction Factor (dB/m)	Reading (dBUV)	Corrected Level (dBUV/m)	Limit @ 3 m (dBUV/m)	Margin (dB)
4924	PK	V	35.1	38.54	53.4	56.84	74	-17.16
4924	AV	V	35.1	38.54	44.32	47.76	54	-6.24
4924	PK	H	35.1	38.54	41.77	45.21	54	-8.79

Remark:

1. Correction Factor = Antenna Factor + Cable Loss
2. Corrected Level = Reading + Correction Factor – Preamp. Gain
3. The frequency measured ranges from 1 GHz to 25 GHz. The data value listed above which is higher than the system noise floor.

EUT : TTD-VMi110
Test Condition : 802.11n HT40 Tx at Channel 3

Frequency (MHz)	Spectrum Analyzer Detector	Antenna Polariz. (H/V)	Preamp. Gain (dB)	Correction Factor (dB/m)	Reading (dBUV)	Corrected Level (dBUV/m)	Limit @ 3 m (dBUV/m)	Margin (dB)
4844	PK	V	35.1	38.54	53.43	56.87	74	-17.13
4844	AV	V	35.1	38.54	44.69	48.13	54	-5.87
4844	PK	H	35.1	38.54	44.48	47.92	54	-6.08

Remark:

1. Correction Factor = Antenna Factor + Cable Loss
2. Corrected Level = Reading + Correction Factor – Preamp. Gain
3. The frequency measured ranges from 1 GHz to 25 GHz. The data value listed above which is higher than the system noise floor.

EUT : TTD-VMi110
Test Condition : 802.11n HT40 Tx at Channel 6

Frequency (MHz)	Spectrum Analyzer Detector	Antenna Polariz. (H/V)	Preamp. Gain (dB)	Correction Factor (dB/m)	Reading (dBuV)	Corrected Level (dBuV/m)	Limit @ 3 m (dBuV/m)	Margin (dB)
4874	PK	V	35.1	38.54	54.35	57.79	74	-16.21
4874	AV	V	35.1	38.54	45.25	48.69	54	-5.31
4874	PK	H	35.1	38.54	41.09	44.53	54	-9.47

Remark:

1. Correction Factor = Antenna Factor + Cable Loss
2. Corrected Level = Reading + Correction Factor – Preamp. Gain
3. The frequency measured ranges from 1 GHz to 25 GHz. The data value listed above which is higher than the system noise floor.

EUT : TTD-VMi110
Test Condition : 802.11n HT40 Tx at Channel 9

Frequency (MHz)	Spectrum Analyzer Detector	Antenna Polariz. (H/V)	Preamp. Gain (dB)	Correction Factor (dB/m)	Reading (dBuV)	Corrected Level (dBuV/m)	Limit @ 3 m (dBuV/m)	Margin (dB)
4904	PK	V	35.1	38.54	54.48	57.92	74	-16.08
4904	AV	V	35.1	38.54	45.29	48.73	54	-5.27
4904	PK	H	35.1	38.54	39.39	42.83	54	-11.17

Remark:

1. Correction Factor = Antenna Factor + Cable Loss
2. Corrected Level = Reading + Correction Factor – Preamp. Gain
3. The frequency measured ranges from 1 GHz to 25 GHz. The data value listed above which is higher than the system noise floor.



9. Emission on Band Edge

Name of Test	Emission Band Edge
Base Standard	FCC 15.247(d)

Test Result: Complies
Measurement Data: See Tables & plots below
Test Date: Jun. 24, 2013

Method of Measurement:

Reference FCC document: KDB558074 D01, ANSI C63.4

The frequency range from 30 MHz to 1000 MHz using Bilog Antenna.

The frequency range over 1 GHz using Horn Antenna.

Radiated emissions were investigated cover the frequency range from 30 MHz to 1000 MHz using a receiver RBW of 120 kHz record QP reading, and the frequency over 1 GHz using a spectrum analyzer RBW of 1 MHz and 10 Hz VBW record Average reading. (15.209 paragraph), the Peak reading (1 MHz RBW/VBW) recorded also on the report.

Channel	Measurement Freq. Band (MHz)	Detector	The Max. Field Strength in Restrict Band (dBuV/m)	Limit @ 3 m (dBuV/m)	Margin (dB)
Test Mode: 802.11b mode					
1 (Lowest)	2310-2430	PK	58.41	74	-15.59
		AV	45.92	54	-8.08
11 (Highest)	2450-2500	PK	57.74	74	-16.26
		AV	46.84	54	-7.16
Test Mode: 802.11g mode					
1 (Lowest)	2310-2430	PK	59.08	74	-14.92
		AV	45.98	54	-8.02
11 (Highest)	2450-2500	PK	63.91	74	-10.09
		AV	47.33	54	-6.67
Test Mode: 802.11n HT20 mode					
1 (Lowest)	2310-2430	PK	59.53	74	-14.47
		AV	47.35	54	-6.65
11 (Highest)	2450-2500	PK	62.68	74	-11.32
		AV	47.51	54	-6.49
Test Mode: 802.11n HT40 mode					
3 (Lowest)	2310-2450	PK	63.35	74	-10.65
		AV	49.84	54	-4.16
9 (Highest)	2430-2500	PK	65.66	74	-8.34
		AV	50.29	54	-3.71

Band edge @ 802.11b mode Channel 1 (PK)

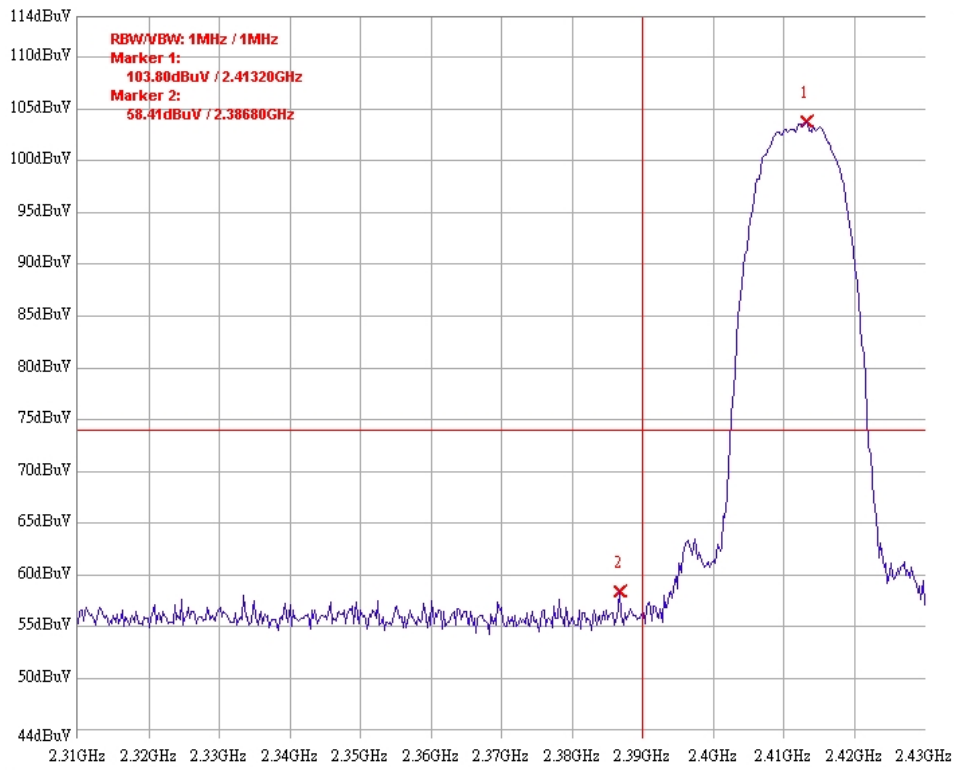

Band edge @ 802.11b mode Channel 1 (AV)

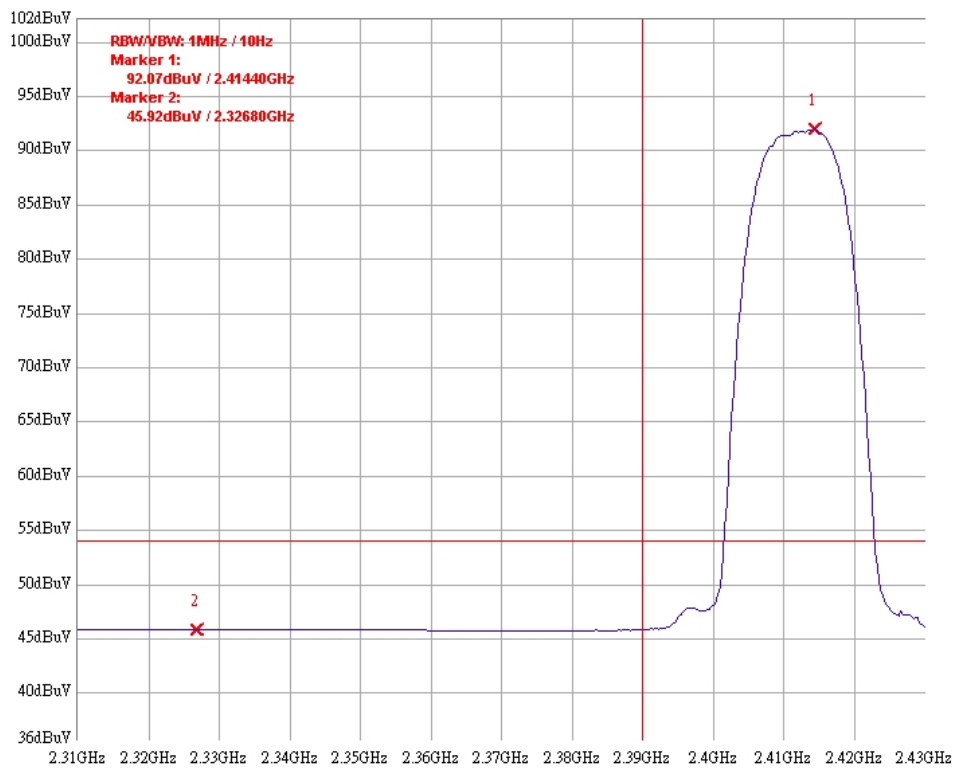

Band edge @ 802.11b mode Channel 11 (PK)

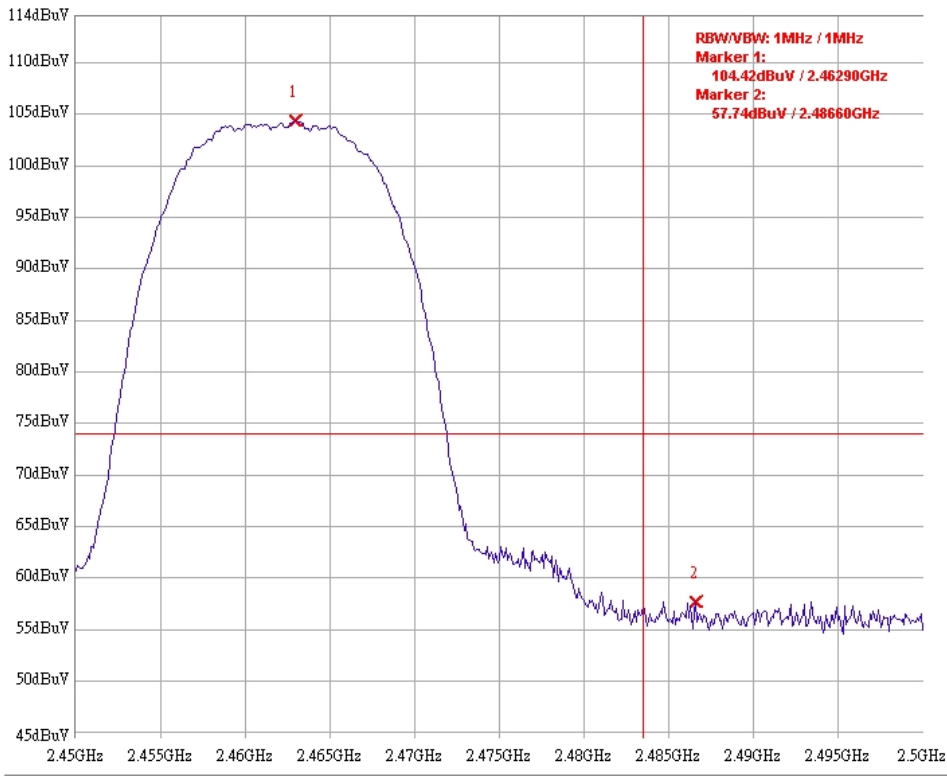

Band edge @ 802.11b mode Channel 11 (AV)

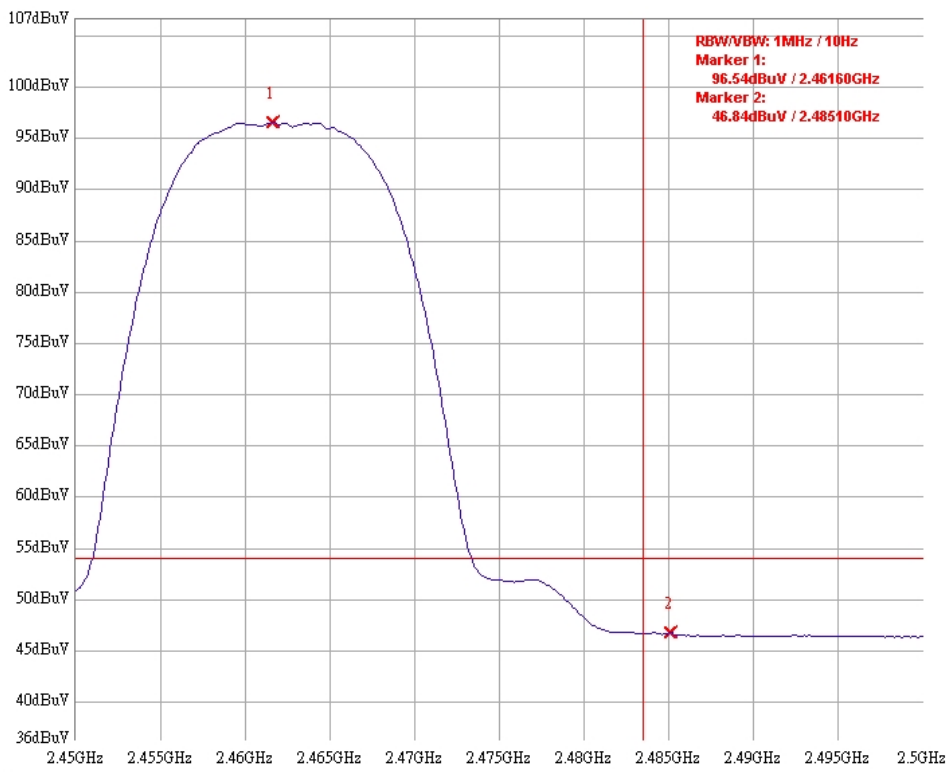

Band edge @ 802.11g mode Channel 1 (PK)

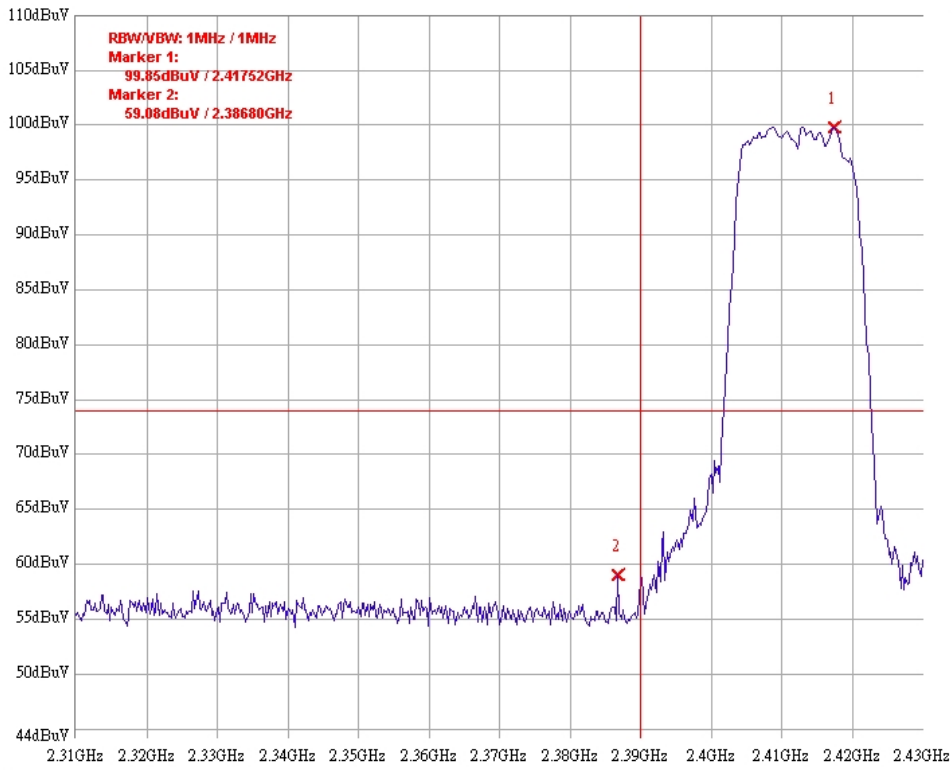

Band edge @ 802.11g mode Channel 1 (AV)

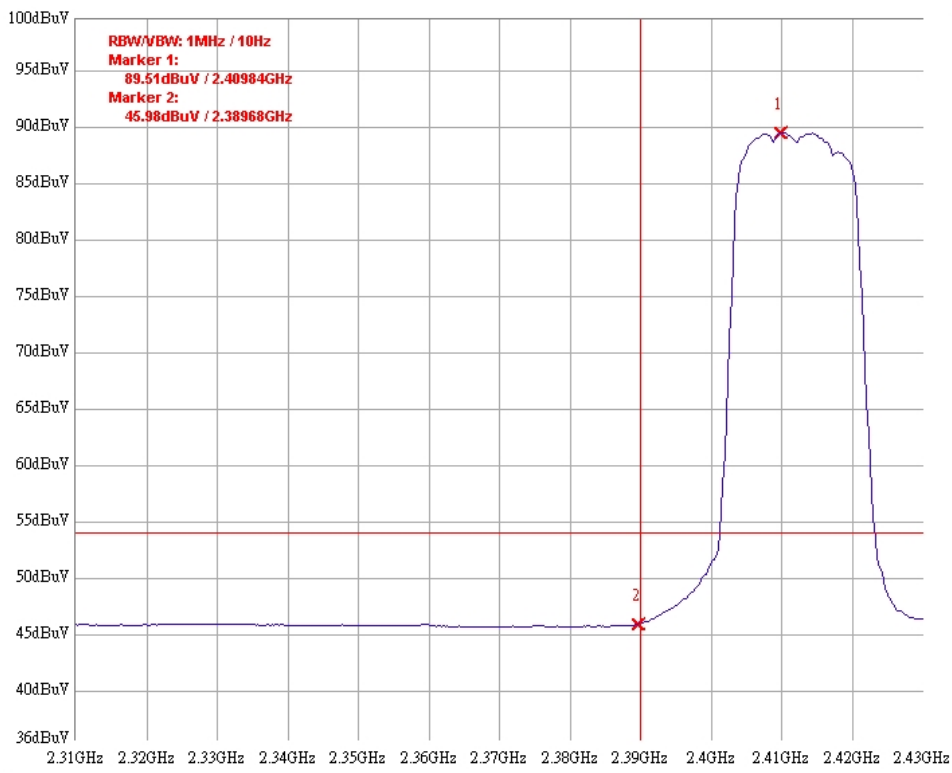

Band edge @ 802.11g mode Channel 11 (PK)

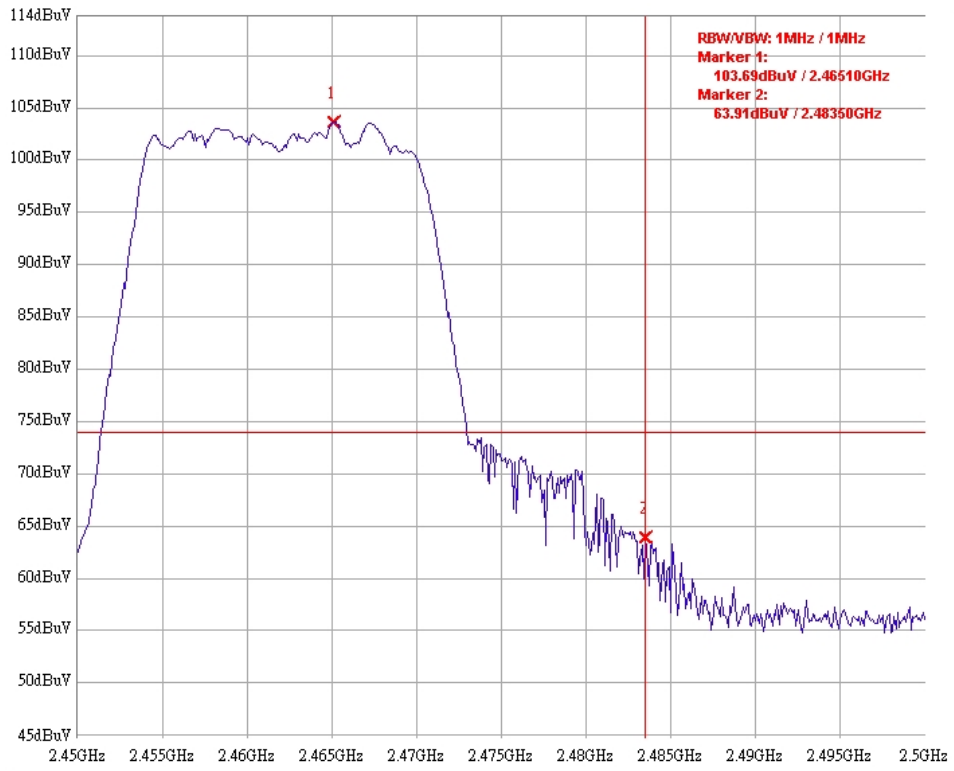

Band edge @ 802.11g mode Channel 11 (AV)

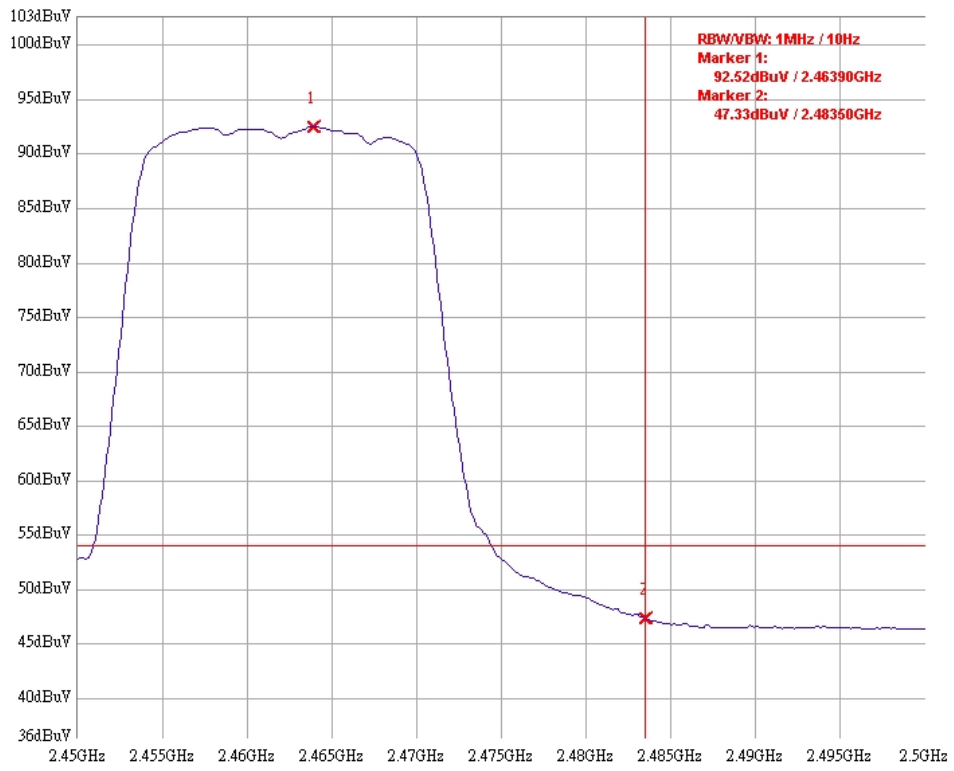

Band edge @ 802.11n HT20 mode Channel 1 (PK)

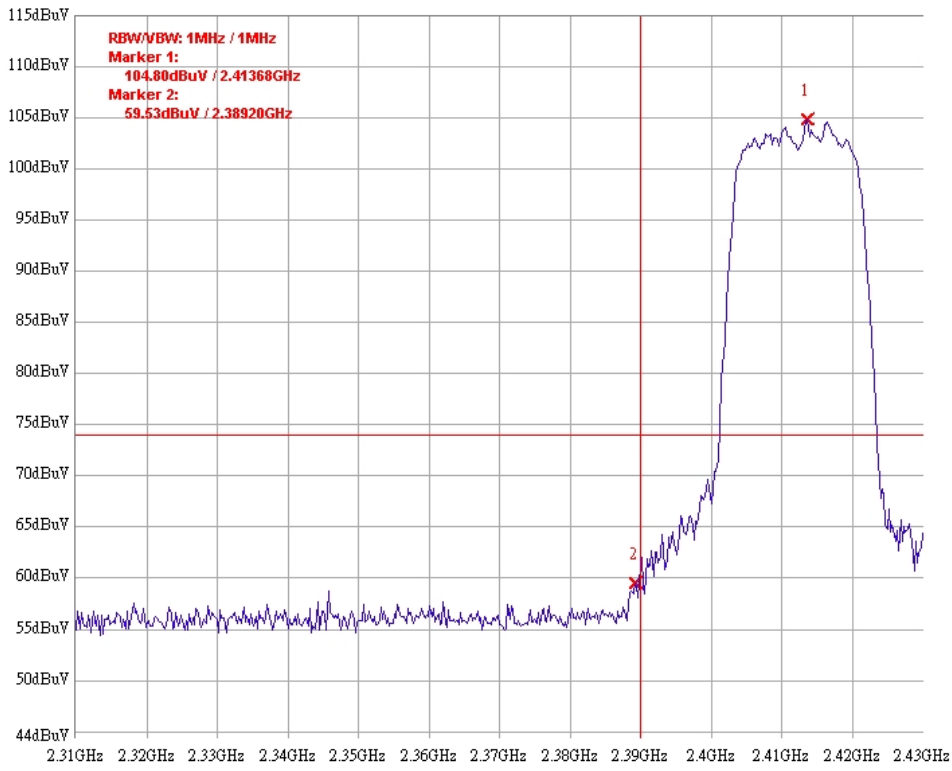

Band edge @ 802.11n HT20 mode Channel 1 (AV)

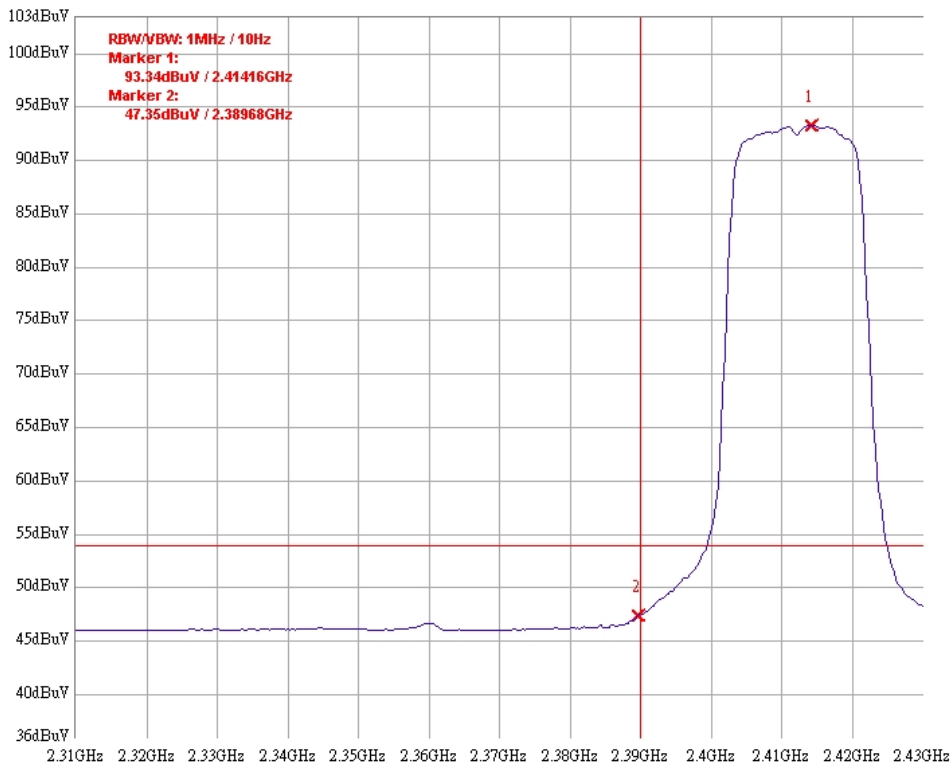

Band edge @ 802.11n HT20 mode Channel 11 (PK)

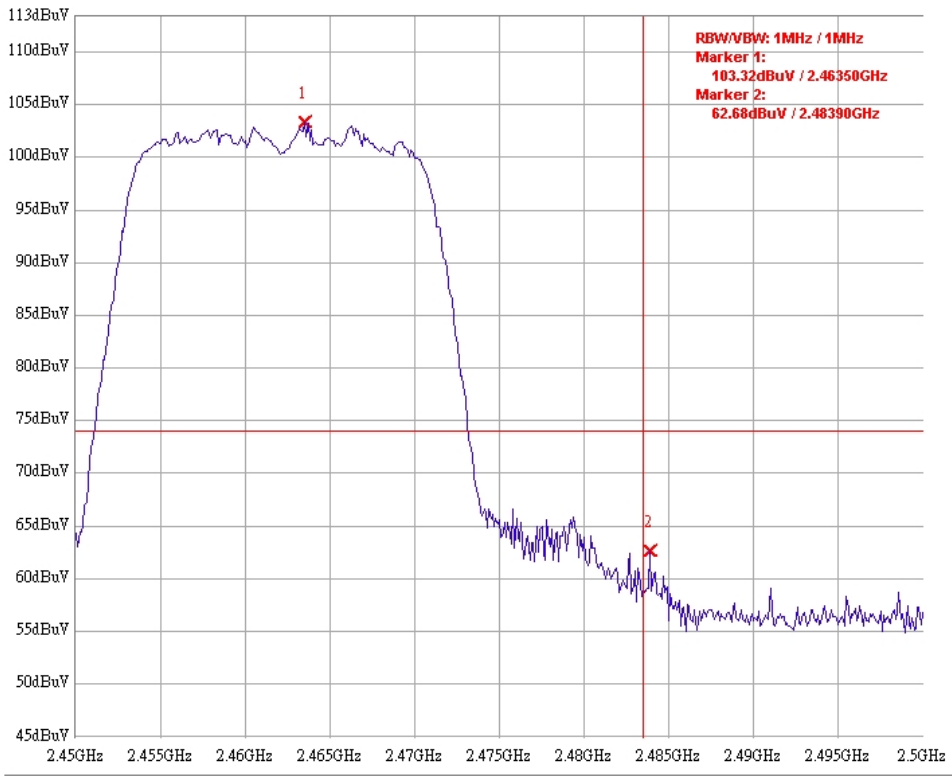

Band edge @ 802.11n HT20 mode Channel 11 (AV)

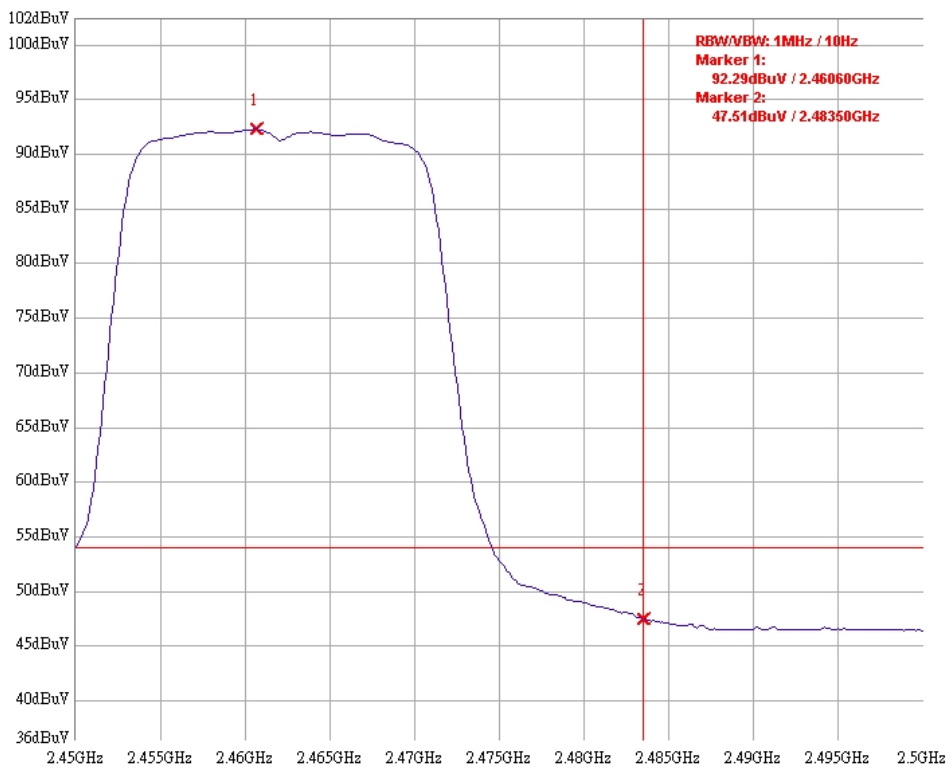

Band edge @ 802.11n HT40 mode Channel 3 (PK)

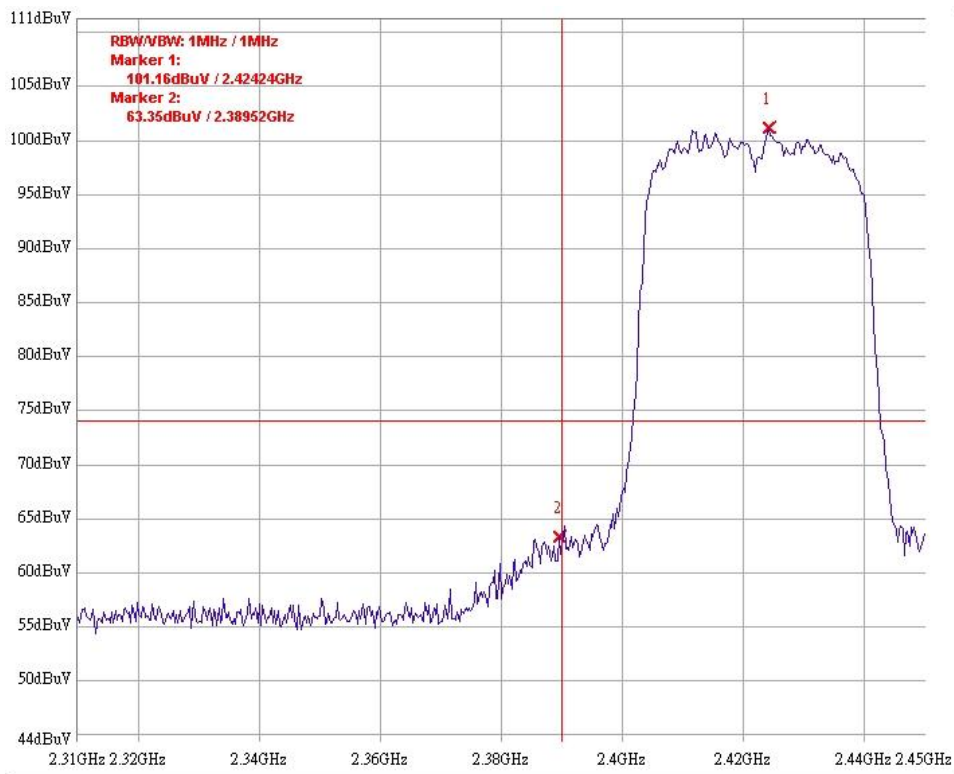

Band edge @ 802.11n HT40 mode Channel 3 (AV)

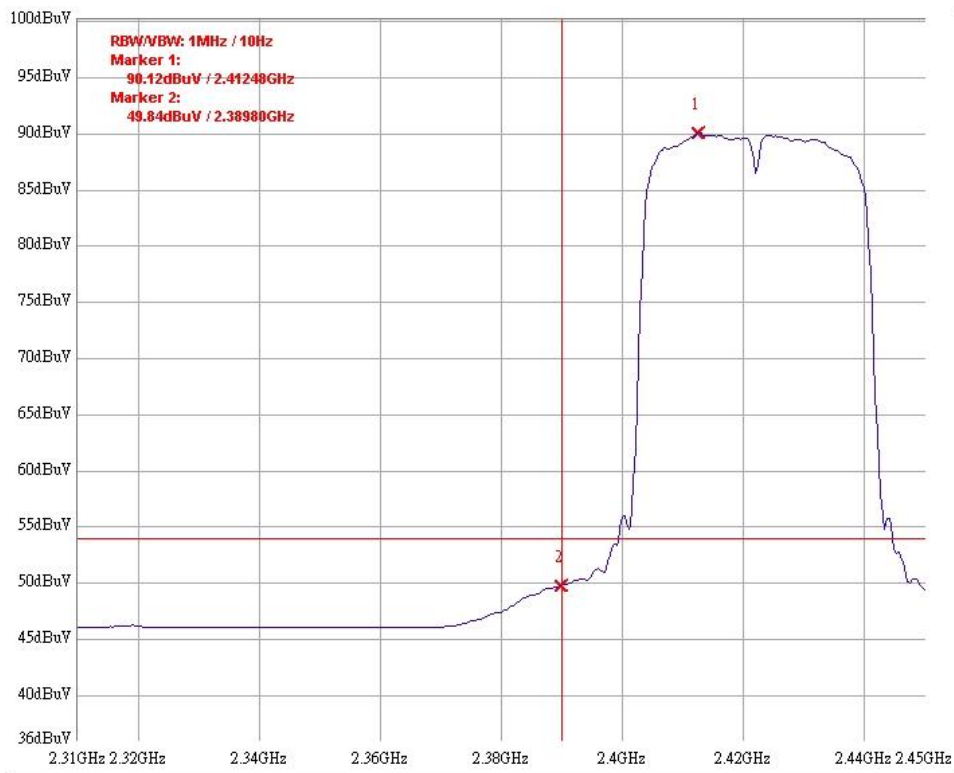

Band edge @ 802.11n HT40 mode Channel 9 (PK)

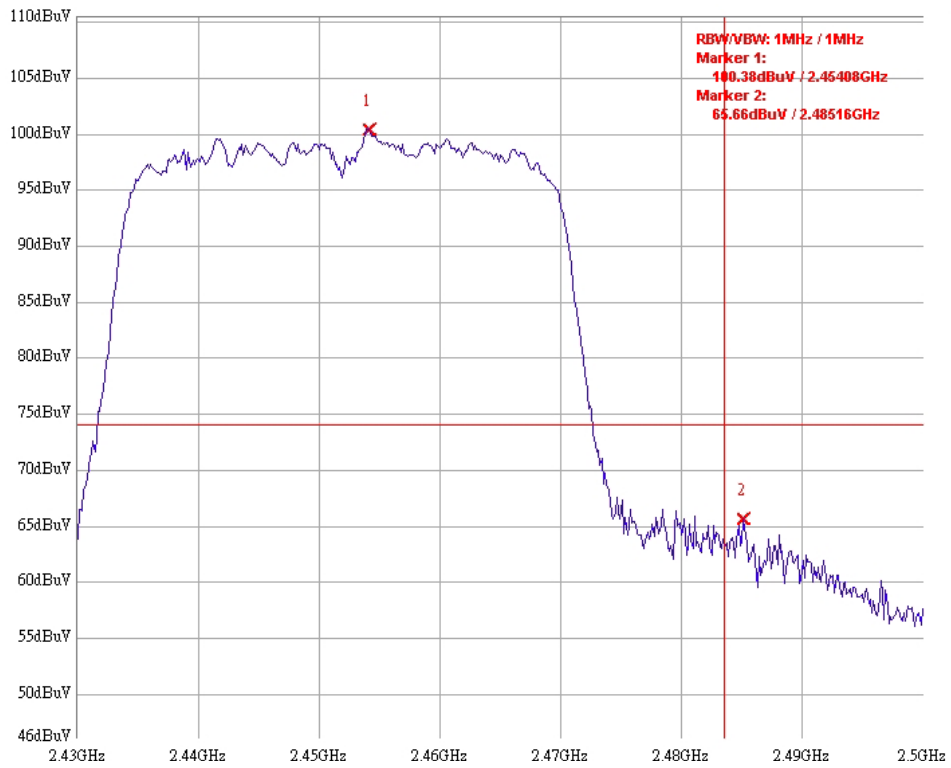

Band edge @ 802.11n HT40 mode Channel 9 (AV)

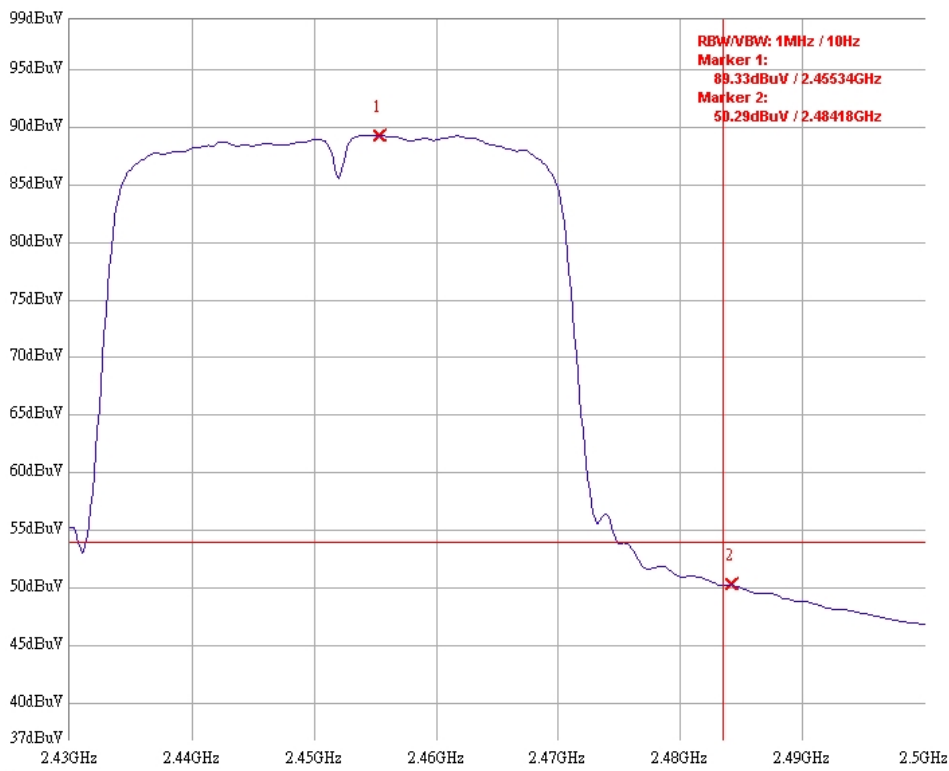

10. AC power line conducted emission

Name of Test	AC power line conducted emission
Base Standard	FCC 15.207

Test Result: Complies
Measurement Data: See Tables & plots below
Test Date: Jan. 02, 2013

Method of Measurement:

Reference FCC document: ANSI C63.4

The EUT are connected to the main power through a line impedance stabilization network (LISN). This provides a 50 ohm/50 uH coupling impedance for the measuring equipment. The peripheral devices are also connected to the main power through a LISN that provides a 50 ohm/ 50 uH coupling impedance with 50 ohm termination. Both sides (Line and Neutral) of AC line are checked for maximum conducted interference. In order to find the maximum emission, the relative positions of equipment and all of the interface cables must be changed according to ANSI C63.4/2003 on conducted measurement.

The bandwidth of the field strength meter (R & S Test Receiver ESCS 30) is set at 9 kHz.

The EUT configuration refers to the "Conducted set-up photo.pdf".

Test Diagram:

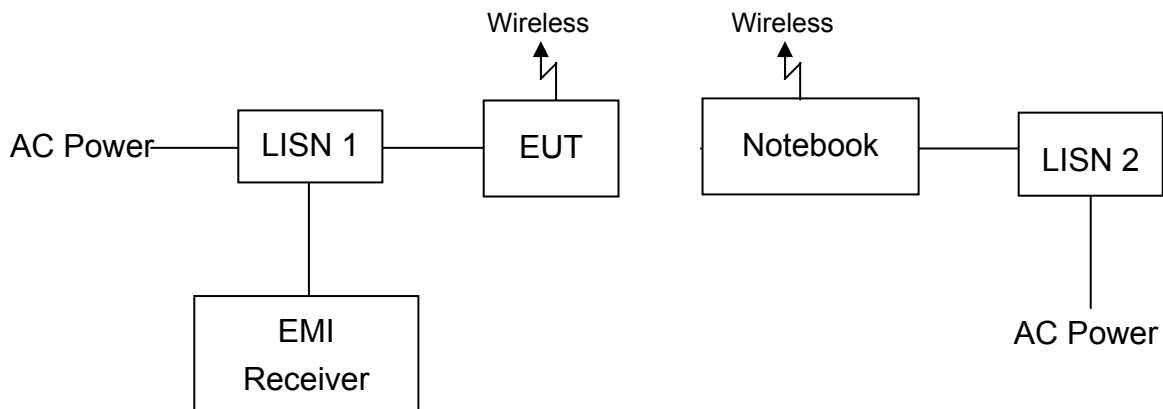

Emission Limit:

Freq. (MHz)	Conducted Limit (dBuV)	
	Q.P.	Ave.
0.15~0.50	66 – 56*	56 – 46*
0.50~5.00	56	46
5.00~30.0	60	50

*Decreases with the logarithm of the frequency.

Note: The EUT was tested while in normal communication mode.

Phase : Line
EUT : TTD-VMi110
Test Condition : Continuously mode

Frequency (MHz)	Corr. Factor (dB)	Level Qp (dBuA)	Limit Qp (dBuA)	Level Av (dBuA)	Limit Av (dBuA)	Margin (dB)	
						Qp	Av
0.672	0.09	41.00	56.00	28.60	46.00	-15.00	-17.40
0.743	0.10	39.76	56.00	27.90	46.00	-16.24	-18.10
0.771	0.10	39.41	56.00	27.90	46.00	-16.59	-18.10
0.839	0.10	41.59	56.00	28.36	46.00	-14.41	-17.64
1.829	0.13	36.38	56.00	23.37	46.00	-19.62	-22.63
2.622	0.16	36.44	56.00	25.11	46.00	-19.56	-20.89

Remark:

1. Correction Factor (dB) = LISN Factor (dB) + Cable Loss (dB)
2. Margin (dB) = Level (dBuV) – Limit (dBuV)

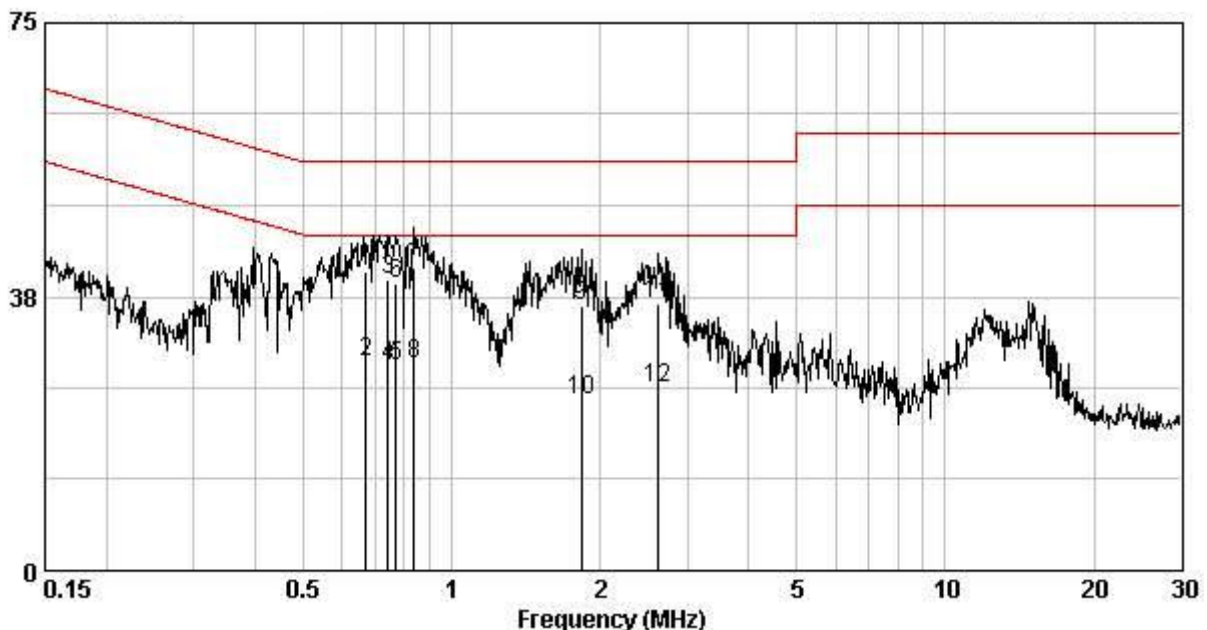

Phase : Neutral
EUT : TTD-VMi110
Test Condition : Continuously mode

Frequency (MHz)	Corr. Factor (dB)	Level Qp (dBuA)	Limit Qp (dBuA)	Level Av (dBuA)	Limit Av (dBuA)	Margin (dB)	
						Qp	Av
0.408	0.18	38.82	57.68	31.75	47.68	-18.86	-15.93
0.708	0.19	37.76	56.00	24.46	46.00	-18.24	-21.54
0.779	0.20	36.49	56.00	19.94	46.00	-19.51	-26.06
0.853	0.20	39.98	56.00	24.31	46.00	-16.02	-21.69
0.923	0.20	37.44	56.00	23.85	46.00	-18.56	-22.15
1.868	0.23	33.93	56.00	22.17	46.00	-22.07	-23.83

Remark:

1. Correction Factor (dB) = LISN Factor (dB) + Cable Loss (dB)
2. Margin (dB) = Level (dBuV) – Limit (dBuV)

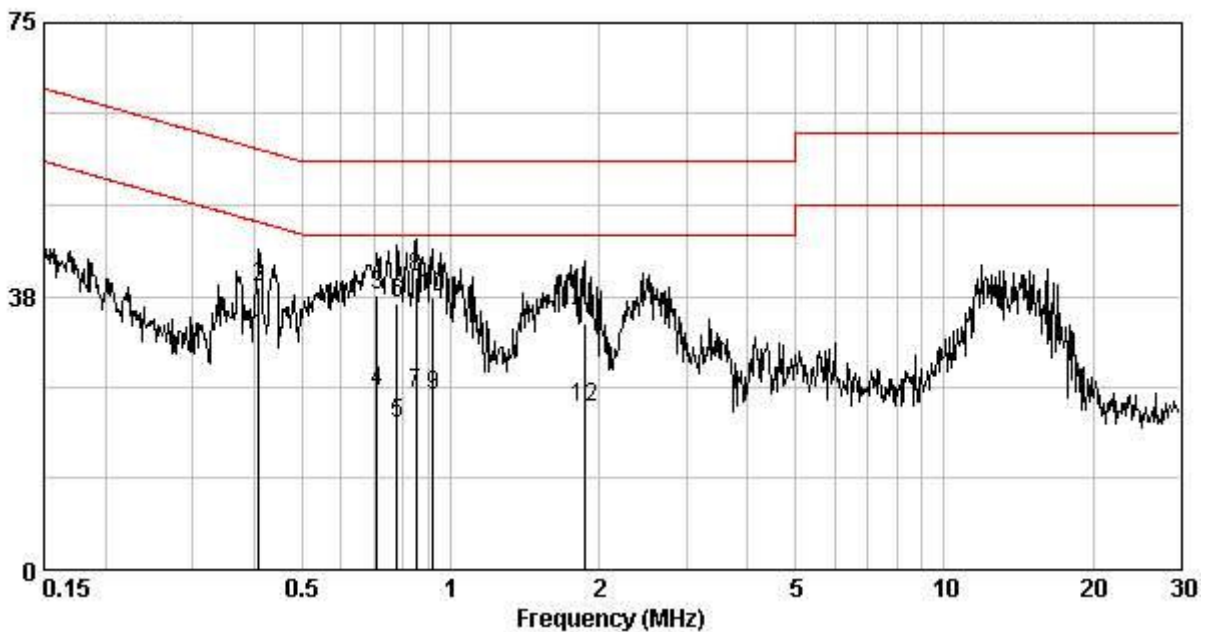

Appendix: Test Equipment List

Equipment	Brand	Model No.	Serial No.	Calibration Date	Next Calibration Date
EMI Test Receiver	Rohde & Schwarz	ESCI	100018	2012/11/30	2013/11/29
Spectrum Analyzer	Rohde&schwarz	FSP30	100137	2012/06/25	2013/06/25
Spectrum Analyzer	Rohde&schwarz	FSEK30	100186	2013/01/23	2014/01/23
Horn Antenna (1-18G)	Schwarzbeck	BBHA 9120 D	9120D-456	2012/09/03	2014/09/03
Horn Antenna (14-42G)	SHWARZBECK	BBHA 9170	BBHA9170159	2012/09/05	2014/09/05
Broadband Antenna	SCHWARZBECK	VULB 9168	9168-172	2011/07/26	2013/07/25
Loop Antenna	RolfHeine	LA-285	02/10033	2012/03/20	2014/03/20
Pre-Amplifier	MITEQ	AFS44-001026 50--42-10P-44	1495287	2011/10/27	2013/10/26
Pre-Amplifier	MITEQ	JS4-26004000-- 27-8A	828825	2012/09/18	2014/09/18
Power Meter	Anritsu	ML2495A	0844001	2012/10/09	2013/10/09
Power Sensor	Anritsu	MA2411B	0738452	2012/10/09	2013/10/09
Temperature&Humidity Test Chamber	TERCHY	MHU-225LRU (SA)	950838	2013/06/14	2014/06/14
Two-Line -V-Network	Rohde&schwarz	ESH3-Z5	825562/003	2012/10/29	2013/10/29
Two-Line V-Network	Rohde&schwarz	ESH3-Z5	838979/014	2012/10/29	2013/10/29

Measurement Uncertainty:

Measurement uncertainty was calculated in accordance with TR 100 028-1.

Parameter	Uncertainty		
Radiated Emission	Below 1 GHz	Vertical	3.90 dB
		Horizontal	3.86 dB
	Above 1 GHz	Vertical	5.74 dB
		Horizontal	5.55 dB
Conducted Emission	2.08 dB		

This uncertainty represents an expanded uncertainty expressed at approximately the 95 % confidence level using a coverage factor of $k=2$.