



SPORTON International Inc.

No. 52, Hwa Ya 1st Rd., Kwei-Shan Hsiang, TaoYuan Hsien, Taiwan, R.O.C.
Ph: 886-3-327-3456 / FAX: 886-3-327-0973 / www.sporton.com.tw

FCC RADIO TEST REPORT

Applicant's company	TRANWO TECHNOLOGY CORP.
Applicant Address	6F., No. 49, Guangming 6th Rd., Jubei City, Hsinchu, Taiwan 302, R.O.C.
FCC ID	O6LTTD-60R
Manufacturer's company	TRANWO TECHNOLOGY CORP.
Manufacturer Address	6F., No. 49, Guangming 6th Rd., Jubei City, Hsinchu, Taiwan 302, R.O.C.

Product Name	Digital Wireless Video Baby Monitor
Brand Name	TRANWO
Model Name	TTD-60R
Test Rule	47 CFR FCC Part 15 Subpart C § 15.247
Test Freq. Range	2400 ~ 2483.5MHz
Received Date	Jun. 29, 2007
Final Test Date	Jan. 23, 2008
Submission Type	Original Equipment



Statement

Test result included is only for the FSK system part of the product.

The test result in this report refers exclusively to the presented test model / sample.

Without written approval of SPORTON International Inc., the test report shall not be reproduced except in full.

The measurements and test results shown in this test report were made in accordance with the procedures and found in compliance with the limit given in **ANSI C63.4-2003** and **47 CFR FCC Part 15 Subpart C**.

The test equipment used to perform the test is calibrated and traceable to NML/ROC.



Table of Contents

1. CERTIFICATE OF COMPLIANCE	1
2. SUMMARY OF THE TEST RESULT	2
3. GENERAL INFORMATION	3
3.1. Product Details.....	3
3.2. Accessories.....	3
3.3. Table for Filed Antenna.....	3
3.4. Table for Carrier Frequencies	4
3.5. Table for Test Modes.....	4
3.6. Table for Testing Locations.....	5
3.7. Table for Supporting Units	5
3.8. Table for Parameters of Test Software Setting	5
3.9. Test Configurations	6
4. TEST RESULT	8
4.1. AC Power Line Conducted Emissions Measurement.....	8
4.2. Maximum Peak Output Power Measurement	12
4.3. Hopping Channel Separation Measurement	14
4.4. Number of Hopping Frequency Measurement.....	19
4.5. Dwell Time Measurement.....	21
4.6. Radiated Emissions Measurement	26
4.7. Band Edge Emissions Measurement	38
4.8. Antenna Requirements	41
5. LIST OF MEASURING EQUIPMENTS	42
6. TEST LOCATION.....	44
7. TAF CERTIFICATE OF ACCREDITATION	45
APPENDIX A. PHOTOGRAPHS OF EUT.....	A1 ~ A13
APPENDIX B. TEST PHOTOS.....	B1 ~ B5



History of This Test Report

Original Issue Date: Feb. 15, 2008

Report No.: FR762901-01

No additional attachment.

Additional attachment were issued as following record:

Attachment No.	Issue Date	Description



1. CERTIFICATE OF COMPLIANCE

Product Name : Digital Wireless Video Baby Monitor
Brand Name : TRANWO
Model Name : TTD-60R
Applicant : TRANWO TECHNOLOGY CORP.
Test Rule Part(s) : 47 CFR FCC Part 15 Subpart C § 15.247

Sporton International as requested by the applicant to evaluate the EMC performance of the product sample received on Jun. 29, 2007 would like to declare that the tested sample has been evaluated and found to be in compliance with the tested rule parts. The data recorded as well as the test configuration specified is true and accurate for showing the sample's EMC nature.

Wayne Hsu

SPORTON INTERNATIONAL INC.

2. SUMMARY OF THE TEST RESULT

Applied Standard: 47 CFR FCC Part 15 Subpart C				
Part	Rule Section	Description of Test	Result	Under Limit
4.1	15.207	AC Power Line Conducted Emissions	Complies	17.24 dB
4.2	15.247(b)(1)	Maximum Peak Conducted Output Power	Complies	26.49 dB
4.3	15.247(a)(1)	Hopping Channel Separation	Complies	-
4.4	15.247(b)(1)	Number of Hopping Frequency	Complies	-
4.5	15.247(a)(1)	Dwell Time	Complies	-
4.6	15.247(d)	Radiated Emissions	Complies	0.15 dB
4.7	15.247(d)	Band Edge Emissions	Complies	7.89 dB
4.8	15.203	Antenna Requirements	Complies	-

Test Items	Uncertainty	Remark
AC Power Line Conducted Emissions	±2.3dB	Confidence levels of 95%
Maximum Peak Conducted Output Power	±0.8dB	Confidence levels of 95%
Hopping Channel Separation	±8.5×10 ⁻⁸	Confidence levels of 95%
Radiated Emissions (9kHz~30MHz)	±0.8dB	Confidence levels of 95%
Radiated Emissions (30MHz~1000MHz)	±1.9dB	Confidence levels of 95%
Radiated / Band Edge Emissions (1GHz~18GHz)	±1.9dB	Confidence levels of 95%
Radiated Emissions (18GHz~40GHz)	±1.9dB	Confidence levels of 95%
Temperature	±0.7°C	Confidence levels of 95%
Humidity	±3.2%	Confidence levels of 95%
DC / AC Power Source	±1.4%	Confidence levels of 95%

3. GENERAL INFORMATION

3.1. Product Details

Items	Description
Power Type	6V DC from adapter ; 3.7V DC from battery
Modulation	FSK Modulation/FHSS
Frequency Range	2400 ~ 2483.5MHz
Channel Number	32
Channel Band Width (99%)	2275.64 kHz
Conducted Output Power	-5.49 dBm
Carrier Frequencies	Please refer to section 3.4
Antenna	Please refer to section 3.3

3.2. Accessories

Power	Brand	Model	Rating
Adapter	HON-KWANG	HK-J105-A06	INPUT: 100-240V AC, 50/60Hz, 0.2A OUTPUT: 6V DC
Li-ion Battery	NEXcell	NK-BL5C	3.7V Li-ion 1000mAh, 34*53/6

3.3. Table for Filed Antenna

Ant.	Brand	Model Name	Antenna Type	Connector	Gain (dBi)
1	WEIYANG	WY07060601G	Dipole Antenna	NA	2.5

3.4. Table for Carrier Frequencies

Channel	Freq (MHz)	Channel	Freq (MHz)	Channel	Freq (MHz)
0	2404.35MHz	15	2435.07	30 (disable)	2465.79
1	2406.398	16	2441.22MHz	31	2478.08MHz
2 (disable)	2408.446	17 (disable)	2439.166	32	2469.886
3	2410.494	18	2441.214	33	2471.934
4	2412.542	19 (disable)	2443.262	34	2473.982
5	2414.59	20	2445.31	35	2476.03
6	2416.638	21	2447.358	36	2478.078
7	2418.686	22	2449.406		
8	2420.734	23	2451.454		
9	2422.782	24	2453.502		
10	2424.83	25	2455.55		
11	2426.878	26	2457.598		
12	2428.926	27	2459.646		
13	2430.974	28	2461.694		
14	2433.022	29 (disable)	2463.742		

Note: channel 2, 17, 19, 29, 30 are disable for channel hopping mode.

3.5. Table for Test Modes

Preliminary tests were performed in different data rate to find the worst radiated emission. The data rate shown in the table below is the worst-case rate with respect to the specific test item. Investigation has been done on all the possible configurations for searching the worst cases. The following table is a list of the test modes shown in this test report.

Test Items	Mode	Channel	Antenna
AC Power Conducted Emissions	Normal Link	-	1
Max. Conducted Output Power	FSK	0/16/31	NA
Hopping Channel Separation	FSK	0/16/31	NA
Number of Hopping Frequency	FSK	-	NA
Dwell Time	FSK	0/16/31	NA
Radiated Emissions Below 1GHz	Normal Link	-	1
Radiated Emissions Above 1GHz	FSK	0/16/31	1
Band Edge Emissions	FSK	0/16/31	1

3.6. Table for Testing Locations

Test Site No.	Site Category	Location	FCC Reg. No.	IC File No.	VCCI Reg. No
03CH03-HY	SAC	Hwa Ya	101377	IC 4088	-
CO04-HY	Conduction	Hwa Ya	101377	IC 4088	-
TH01-HY	OVEN Room	Hwa Ya	-	-	-

Open Area Test Site (OATS); Semi Anechoic Chamber (SAC); Fully Anechoic Chamber (FAC).

Please refer section 6 for Test Site Address.

3.7. Table for Supporting Units

Support Unit	Brand	Model	FCC ID
Camera	TRANWO	TTD-40T	O6LTDD-40T

3.8. Table for Parameters of Test Software Setting

During testing, Channel & Power Controlling Software provided by the customer was used to control the operating channel as well as the output power level. The RF output power selection is for the setting of RF output power expected by the customer and is going to be fixed on the firmware of the final end product.

Power Parameters of Bluetooth

Test Software Version	No Test Software		
Frequency	2404.35MHz	2441.22MHz	2478.08MHz
Power Parameters	DEFAULT	DEFAULT	DEFAULT

During the test, the camera transmits audio and colour motion video to monitor.

3.9. Test Configurations

3.9.1. Radiation Emissions Test Configuration

30MHz~1GHz

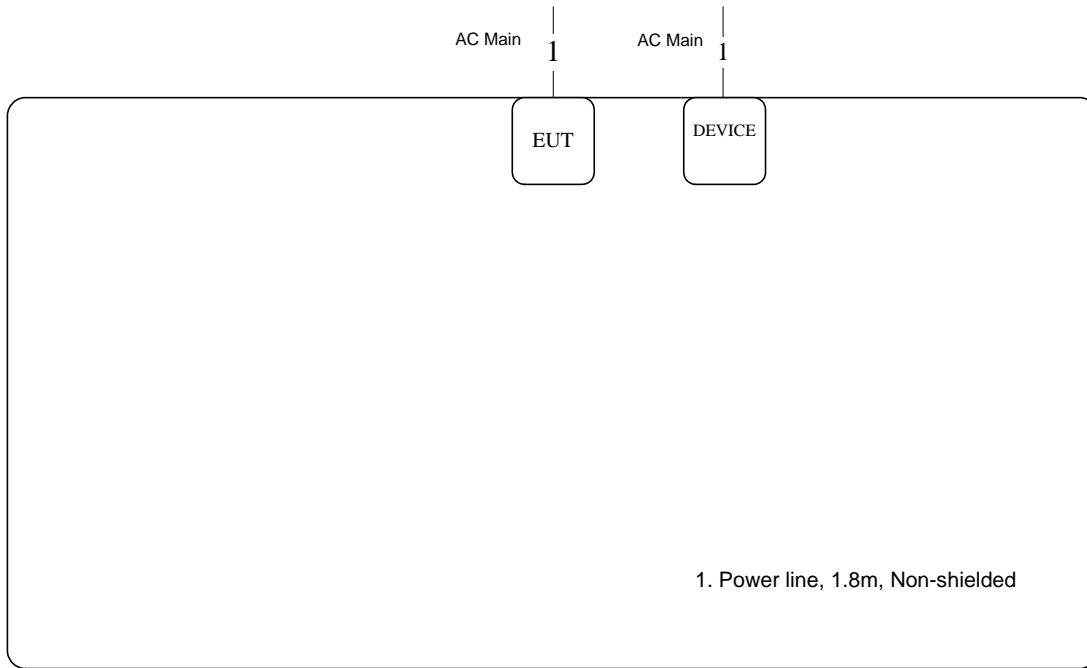

Above 1GHz

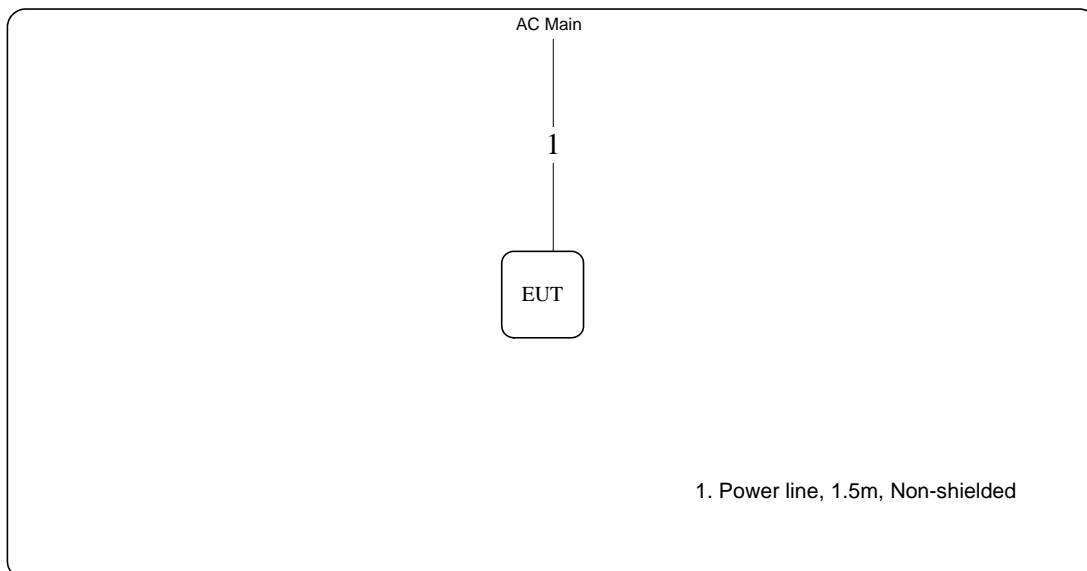

3.9.2. AC Power Line Conduction Emissions Test Configuration

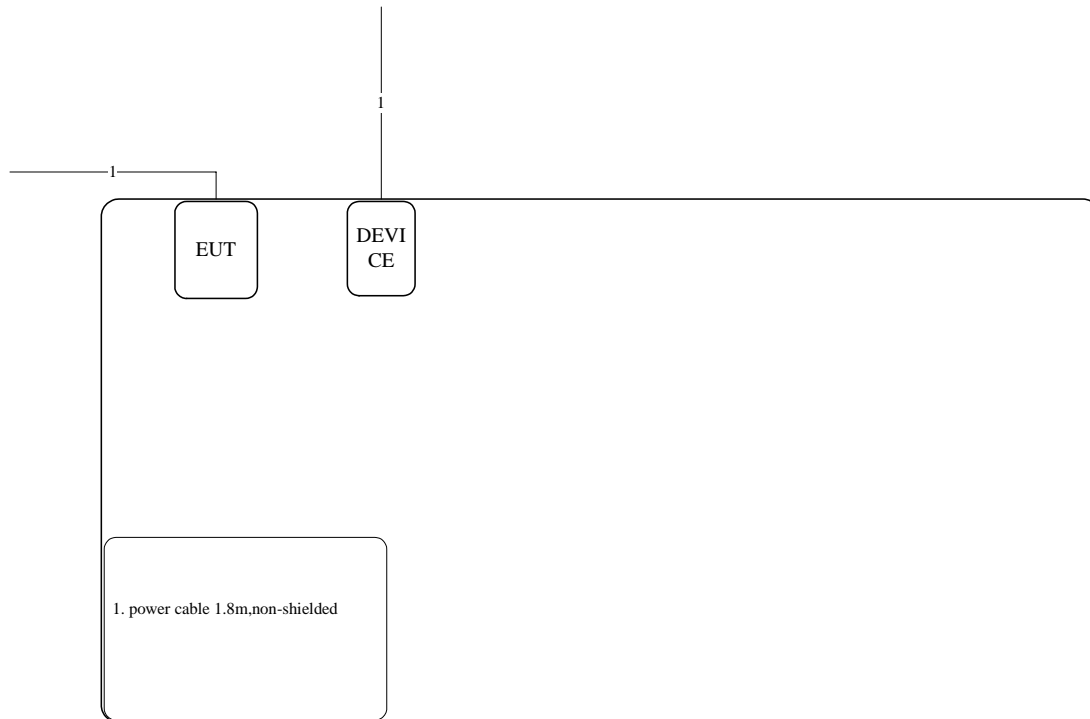

4. TEST RESULT

4.1. AC Power Line Conducted Emissions Measurement

4.1.1. Limit

For a Low-power Radio-frequency Device which is designed to be connected to the AC power line, the radio frequency voltage that is conducted back onto the AC power line on any frequency or frequencies within the band 150 kHz to 30 MHz shall not exceed below limits table.

Frequency (MHz)	QP Limit (dBuV)	AV Limit (dBuV)
0.15~0.5	66~56	56~46
0.5~5	56	46
5~30	60	50

4.1.2. Measuring Instruments and Setting

Please refer to section 5 of equipments list in this report. The following table is the setting of the receiver.

Receiver Parameters	Setting
Attenuation	10 dB
Start Frequency	0.15 MHz
Stop Frequency	30 MHz
IF Bandwidth	9 KHz

4.1.3. Test Procedures

1. Configure the EUT according to ANSI C63.4. The EUT or host of EUT has to be placed 0.4 meter far from the conducting wall of the shielding room and at least 80 centimeters from any other grounded conducting surface.
2. Connect EUT or host of EUT to the power mains through a line impedance stabilization network (LISN).
3. All the support units are connected to the other LISNs. The LISN should provide 50uH/50ohms coupling impedance.
4. The frequency range from 150 KHz to 30 MHz was searched.
5. Set the test-receiver system to Peak Detect Function and Specified Bandwidth with Maximum Hold Mode.
6. The measurement has to be done between each power line and ground at the power terminal.

4.1.4. Test Setup Layout

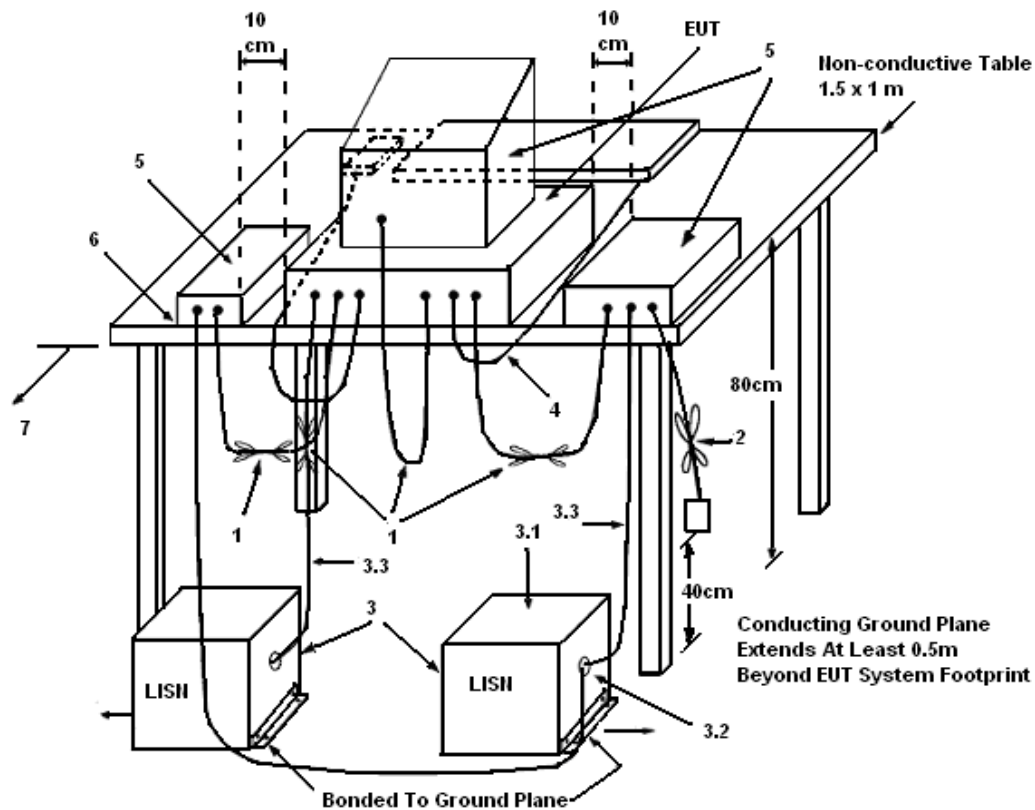

LEGEND:

- (1) Interconnecting cables that hang closer than 40 cm to the ground plane shall be folded back and forth in the center forming a bundle 30 to 40 cm long.
- (2) I/O cables that are not connected to a peripheral shall be bundled in the center. The end of the cable may be terminated, if required, using the correct terminating impedance. The overall length shall not exceed 1 m.
- (3) EUT connected to one LISN. Unused LISN measuring port connectors shall be terminated in 50Ω . LISN can be placed on top of, or immediately beneath, reference ground plane.
- (3.1) All other equipment powered from additional LISN(s).
- (3.2) Multiple outlet strip can be used for multiple power cords of non-EUT equipment.
- (3.3) LISN at least 80 cm from nearest part of EUT chassis.
- (4) Cables of hand-operated devices, such as keyboards, mice, etc., shall be placed as for normal use.
- (5) Non-EUT components of EUT system being tested.
- (6) Rear of EUT, including peripherals, shall all be aligned and flush with rear of tabletop.
- (7) Rear of tabletop shall be 40 cm removed from a vertical conducting plane that is bonded to the ground plane.

4.1.5. Test Deviation

There is no deviation with the original standard.

4.1.6. EUT Operation during Test

The EUT was placed on the test table and programmed in normal function.

4.1.7. Results of AC Power Line Conducted Emissions Measurement

Temperature	23°C	Humidity	45%
Test Engineer	Andy Tsai	Phase	Line
Configuration	Normal Link		

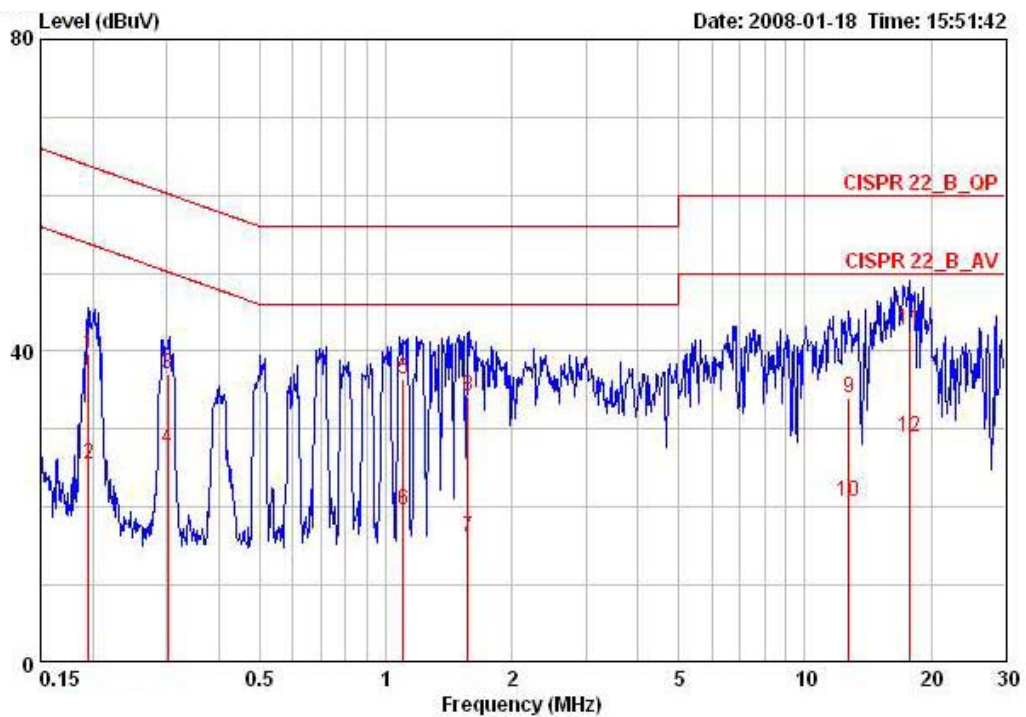

	Freq	Level	Over Limit	Limit Line	Read Level	LISN Factor	Cable Loss	Remark	Pol/Phase
	MHz	dBuV	dB	dBuV	dBuV	dB	dB		
1	0.19550	39.76	-24.04	63.80	39.46	0.10	0.20	QP	LINE
2	0.19550	25.51	-28.29	53.80	25.21	0.10	0.20	AVERAGE	LINE
3	0.30109	37.01	-23.20	60.21	36.71	0.10	0.20	QP	LINE
4	0.30109	27.49	-22.72	50.21	27.19	0.10	0.20	AVERAGE	LINE
5	1.101	36.41	-19.59	56.00	36.23	0.00	0.18	QP	LINE
6	1.101	19.56	-26.44	46.00	19.38	0.00	0.18	AVERAGE	LINE
7	1.567	16.21	-29.79	46.00	16.10	0.00	0.11	AVERAGE	LINE
8	1.567	34.24	-21.76	56.00	34.13	0.00	0.11	QP	LINE
9	12.716	34.07	-25.93	60.00	33.57	0.10	0.40	QP	LINE
10	12.716	20.77	-29.23	50.00	20.27	0.10	0.40	AVERAGE	LINE
11	17.837	42.76	-17.24	60.00	42.16	0.10	0.50	QP	LINE
12	17.837	28.90	-21.10	50.00	28.30	0.10	0.50	AVERAGE	LINE

Temperature	23°C	Humidity	45%
Test Engineer	Andy Tsai	Phase	Neutral
Configuration	Normal Link		

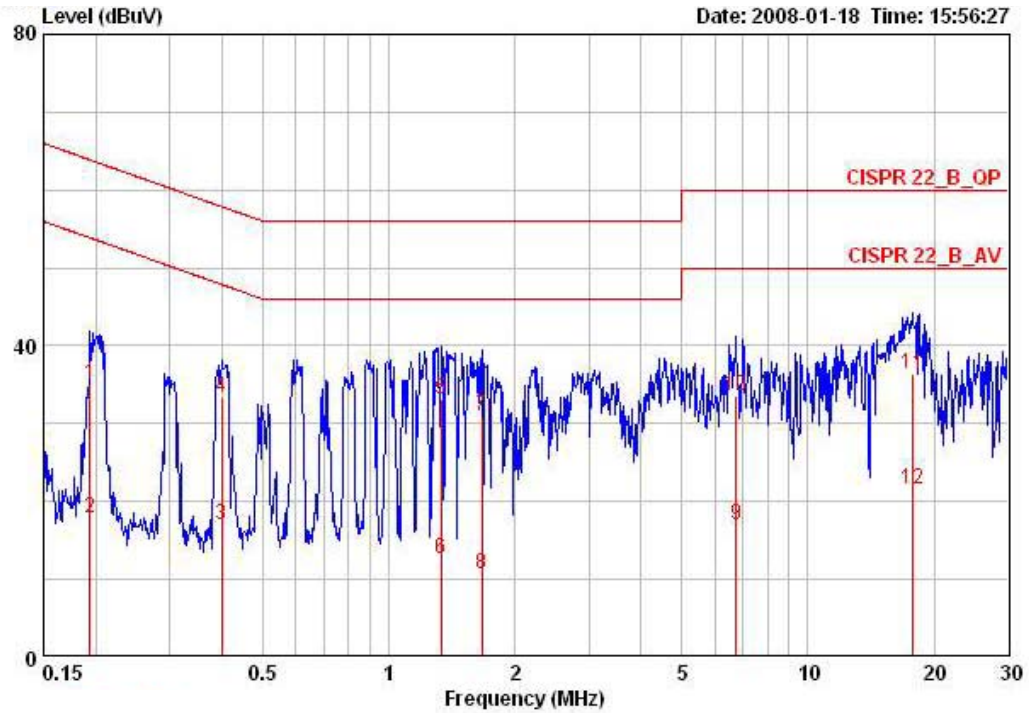

	Freq	Level	Over	Limit	Read	LISN	Cable	Remark	Pol/Phase
	MHz	dBuV	Limit	Line	Level	Factor	Loss		
			dB	dBuV	dBuV	dB	dB		
1	0.19344	35.08	-28.81	63.89	34.63	0.25	0.20	QP	NEUTRAL
2	0.19344	17.90	-35.99	53.89	17.45	0.25	0.20	AVERAGE	NEUTRAL
3	0.39974	17.03	-30.83	47.86	16.73	0.10	0.20	AVERAGE	NEUTRAL
4	0.39974	33.36	-24.50	57.86	33.06	0.10	0.20	QP	NEUTRAL
5	1.331	33.20	-22.80	56.00	32.97	0.10	0.13	QP	NEUTRAL
6	1.331	12.70	-33.30	46.00	12.47	0.10	0.13	AVERAGE	NEUTRAL
7	1.671	30.96	-25.04	56.00	30.72	0.10	0.14	QP	NEUTRAL
8	1.671	10.72	-35.28	46.00	10.48	0.10	0.14	AVERAGE	NEUTRAL
9	6.738	16.90	-33.10	50.00	16.45	0.10	0.35	AVERAGE	NEUTRAL
10	6.738	33.55	-26.45	60.00	33.10	0.10	0.35	QP	NEUTRAL
11	17.755	36.34	-23.66	60.00	35.74	0.10	0.50	QP	NEUTRAL
12	17.755	21.60	-28.40	50.00	21.00	0.10	0.50	AVERAGE	NEUTRAL

Note:

Level = Read Level + LISN Factor + Cable Loss.

4.2. Maximum Peak Output Power Measurement

4.2.1. Limit

For frequency hopping systems operating in the 2400-2483.5 MHz band employing at least 75 non-overlapping hopping channels, and all frequency hopping systems in the 5725-5850 MHz Band: 1 watt. For all other frequency hopping systems in the 2400-2483.5 MHz band: 0.125 watts.

4.2.2. Measuring Instruments and Setting

Please refer to section 5 of equipments list in this report. The following table is the setting of the power meter.

Power Meter Parameter	Setting
Filter No.	Auto
Measurement time	0.135 s ~ 26 s
Used Peak Sensor	NRV-Z32

4.2.3. Test Procedures

1. The transmitter output (antenna port) was connected to the power meter.
2. Turn on the EUT and power meter and then record the peak power value.
3. Repeat above procedures on all channels needed to be tested.

4.2.4. Test Setup Layout

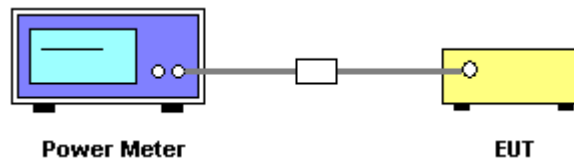

4.2.5. Test Deviation

There is no deviation with the original standard.

4.2.6. EUT Operation during Test

The EUT was programmed to be in continuously transmitting mode.

4.2.7. Test Result of Maximum Peak Output Power

Temperature	25°C	Humidity	60%
Test Engineer	Beck Wu	Configurations	Normal Link

Channel	Frequency	Conducted Power (dBm)	Max. Limit (dBm)	Result
0	2404.35MHz	-6.32	21.00	Complies
16	2441.22MHz	-5.83	21.00	Complies
31	2478.08MHz	-5.49	21.00	Complies

4.3. Hopping Channel Separation Measurement

4.3.1. Limit

Frequency hopping systems shall have hopping channel carrier frequencies separated by a minimum of 25 kHz or the 20 dB bandwidth of the hopping channel, whichever is greater. Alternatively, frequency hopping systems operating in the 2400-2483.5 MHz band may have hopping channel carrier frequencies that are separated by 25 kHz or two-thirds of the 20 dB bandwidth of the hopping channel, whichever is greater.

4.3.2. Measuring Instruments and Setting

Please refer to section 5 of equipments list in this report. The following table is the setting of spectrum analyzer.

Spectrum Parameter	Setting
Attenuation	Auto
Span Frequency	> Measurement Bandwidth or Channel Separation
RB	30 kHz (20dB Bandwidth) / 100 kHz (Channel Separation)
VB	100 kHz (20dB Bandwidth) / 300 kHz (Channel Separation)
Detector	Peak
Trace	Max Hold
Sweep Time	Auto

4.3.3. Test Procedures

1. The transmitter output (antenna port) was connected to the spectrum analyser in peak hold mode.
2. The resolution bandwidth of 30 kHz and the video bandwidth of 100 kHz were utilised for 20 dB bandwidth measurement.
3. The resolution bandwidth of 100 kHz and the video bandwidth of 300 kHz were utilised for channel separation measurement.

4.3.4. Test Setup Layout

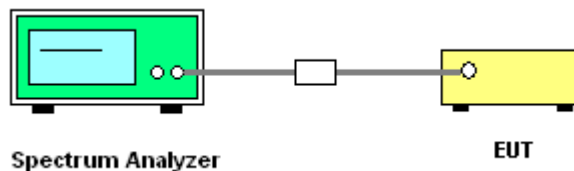

4.3.5. Test Deviation

There is no deviation with the original standard.

4.3.6. EUT Operation during Test

The EUT was programmed to be in continuously transmitting mode.

4.3.7. Test Result of Hopping Channel Separation

Temperature	25°C	Humidity	60%
Test Engineer	Beck Wu	Configurations	Normal Link

Frequency	Ch. Separation (kHz)	20dB Bandwidth (kHz)	99% Occupied Bandwidth (kHz)	Result
2404.35MHz	2048.00	2285.25	2275.64	Complies
2441.22MHz	2048.00	2179.48	2163.46	Complies
2478.08MHz	2048.00	1826.92	2115.38	Complies

Ch. Separation Limits: >20dB bandwidth or >2/3 of 20dB bandwidth

20 dB Bandwidth Plot on Channel 0 / 2404.35MHz

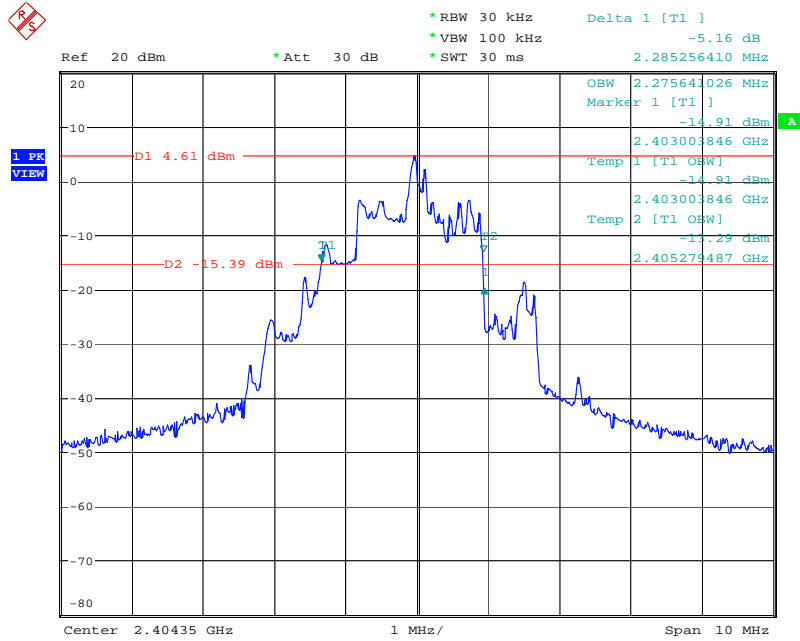

Date: 31.JAN.2008 09:15:00

20 dB Bandwidth Plot on Channel 16 / 2441.22MHz

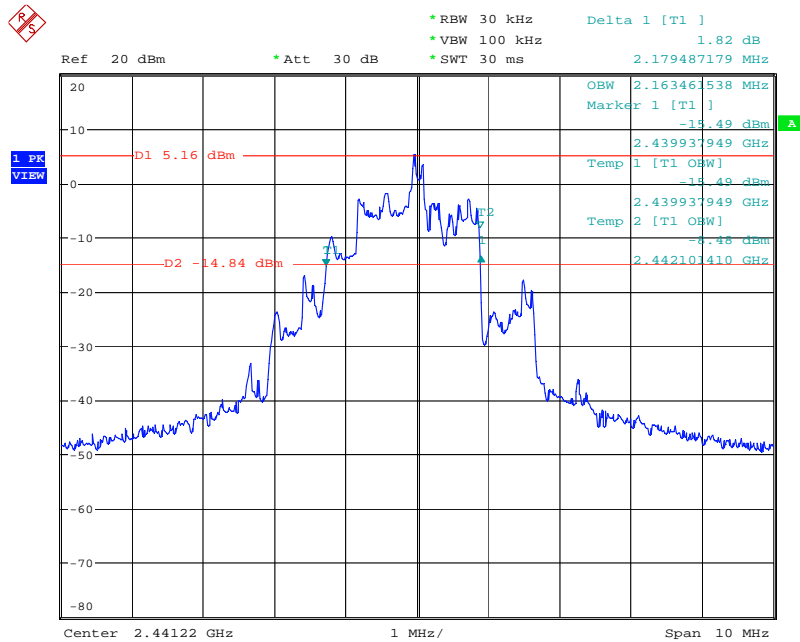

Date: 31.JAN.2008 09:18:15

20 dB Bandwidth Plot on Channel 31 / 2478.08MHz

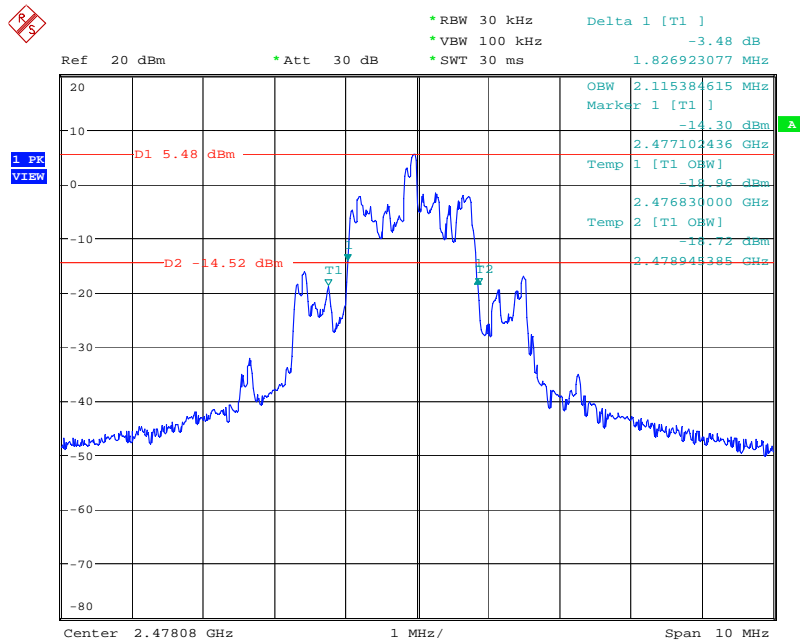

Date: 31.JAN.2008 09:28:00

Channel Separation Plot on Channel 0 / 2404.35MHz



Date: 31.JAN.2008 10:05:21

Channel Separation Plot on Channel 16 / 2441.22MHz

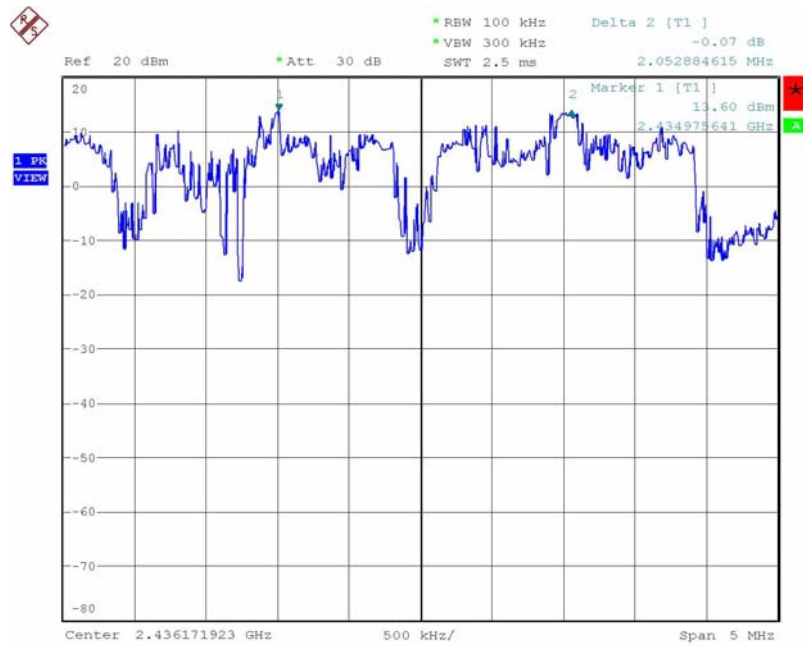

Date: 31.JAN.2008 10:08:11

Channel Separation Plot on Channel 31 / 2478.08MHz



Date: 31.JAN.2008 10:12:32

4.4. Number of Hopping Frequency Measurement

4.4.1. Limit

For frequency hopping systems operating in the 2400-2483.5 MHz band employing at least 15 non-overlapping hopping channels.

4.4.2. Measuring Instruments and Setting

Please refer to section 5 of equipments list in this report. The following table is the setting of spectrum analyzer.

Spectrum Parameters	Setting
Attenuation	Auto
Span Frequency	> Operating Frequency Range
RB	100 kHz
VB	100 kHz
Detector	Peak
Trace	Max Hold
Sweep Time	Auto

4.4.3. Test Procedures

1. The transmitter output (antenna port) was connected to the spectrum analyser in peak hold mode.
2. The resolution bandwidth of 100 kHz and the video bandwidth of 100 kHz were utilised.
3. Observe frequency hopping in 2400MHz~2483.5MHz, there are at least 75 non-overlapping channels.

4.4.4. Test Setup Layout

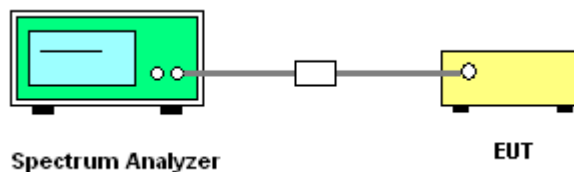

4.4.5. Test Deviation

There is no deviation with the original standard.

4.4.6. EUT Operation during Test

The EUT was programmed to be in continuously transmitting mode.

4.4.7. Test Result of Number of Hopping Frequency

Temperature	25°C	Humidity	60%
Test Engineer	Beck Wu	Configurations	Normal Link

Modulation Type	Frequency (MHz)	Hopping Ch. (Channels)	Min. Limit (Channels)	Test Result
FSK	2404 ~ 2478	32	15	Complies

Number of Hopping Channel Plot on Channel 0~78 / 2404.35MHz ~ 2478.08MHz

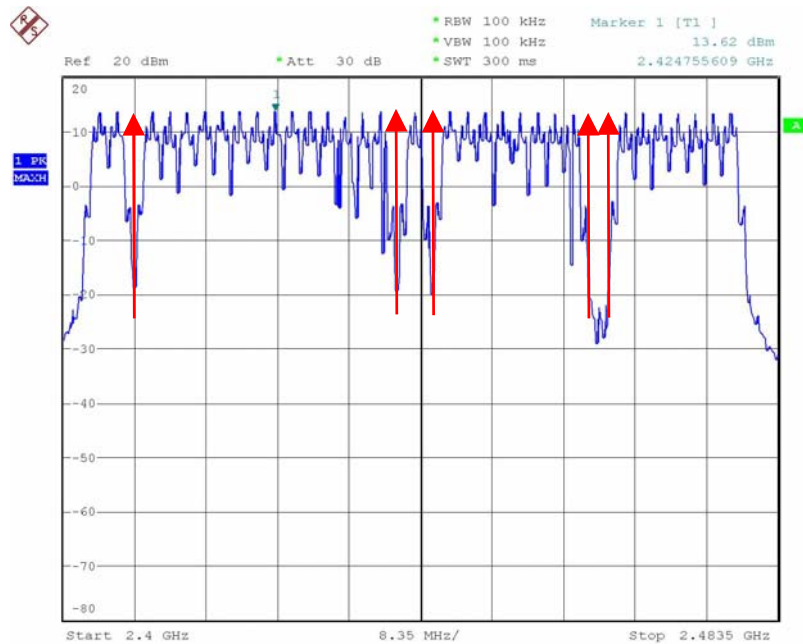

Date: 29.DEC.2007 21:53:33

4.5. Dwell Time Measurement

4.5.1. Limit

Frequency hopping systems in the 2400-2483.5 MHz band shall use at least 15 channels. The average time of occupancy on any channel shall not be greater than 0.4 seconds within a period of 0.4 seconds multiplied by the number of hopping channels employed.

4.5.2. Measuring Instruments and Setting

Please refer to section 5 of equipments list in this report. The following table is the setting of spectrum analyzer.

Spectrum Parameter	Setting
Attenuation	Auto
Span Frequency	0 MHz
RB	1000 kHz
VB	1000 kHz
Detector	Peak
Trace	Single Trigger

4.5.3. Test Procedures

1. The transmitter output (antenna port) was connected to the spectrum analyzer
2. Set RBW of spectrum analyzer to 1000kHz and VBW to 1000kHz.
3. Use a video trigger with the trigger level set to enable triggering only on full pulses.
4. Sweep Time is more than once pulse time.
5. Set the center frequency on any frequency would be measure and span to zero span.
6. Measure the maximum time duration of one single pulse.
7. Count the number of pulses in the dwell time duration (0.4 seconds multiplied by the number of hopping channels).
8. $Dwell\ time = \text{pulse duration} \times \text{number of pulses} / \text{measure time} \times \text{dwell time duration}$.

4.5.4. Test Setup Layout

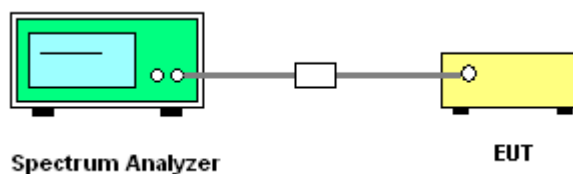

4.5.5. Test Deviation

There is no deviation with the original standard.

4.5.6. EUT Operation during Test

The EUT was programmed to be in continuously transmitting mode.

4.5.7. Test Result of Dwell Time

Temperature	25°C	Humidity	60%
Test Engineer	Beck Wu	Configurations	Normal Link

Frequency	Pulse Duration (ms)	Number of Pulses	Measure Time (s)	Dwell time duration (s)	Dwell Time (s)	Limits (s)	Test\ Result
2404.35MHz	0.4240	13	1	12.80	0.0706	0.4000	Complies
2441.22MHz	0.3807	13	1	12.80	0.0633	0.4000	Complies
2478.08MHz	0.3764	13	1	12.80	0.0626	0.4000	Complies

Single Pulse Plot on Channel 0 / 2404.35MHz

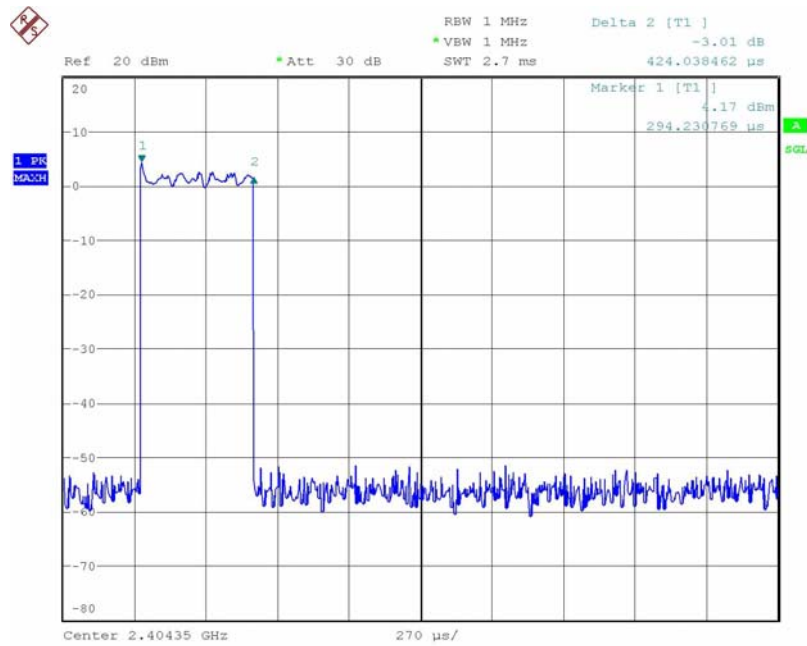

Date: 29.DEC.2007 21:12:45

Number of Pulses Plot on Channel 0 / 2404.35MHz

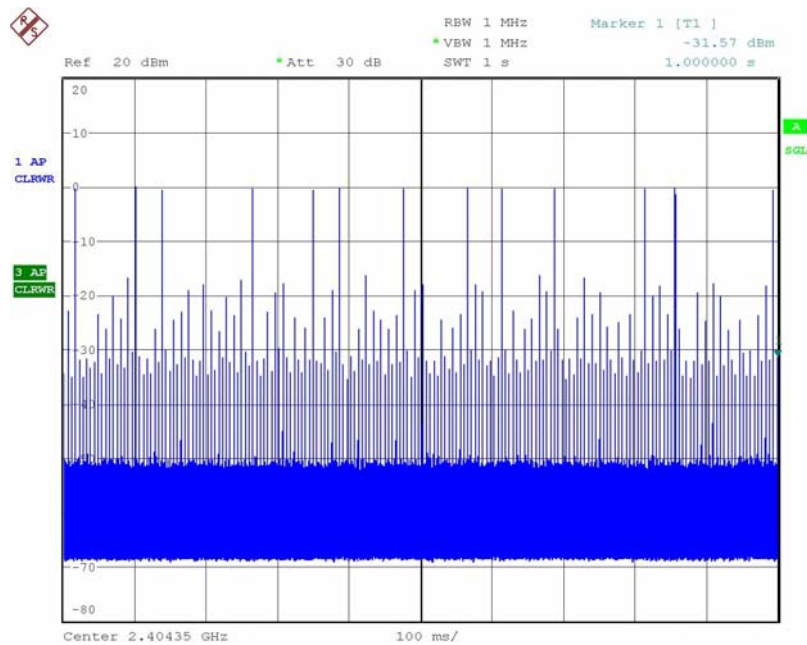

Date : 29.DEC.2007 20:51:49

Single Pulse Plot on Channel 16 / 2441.22MHz

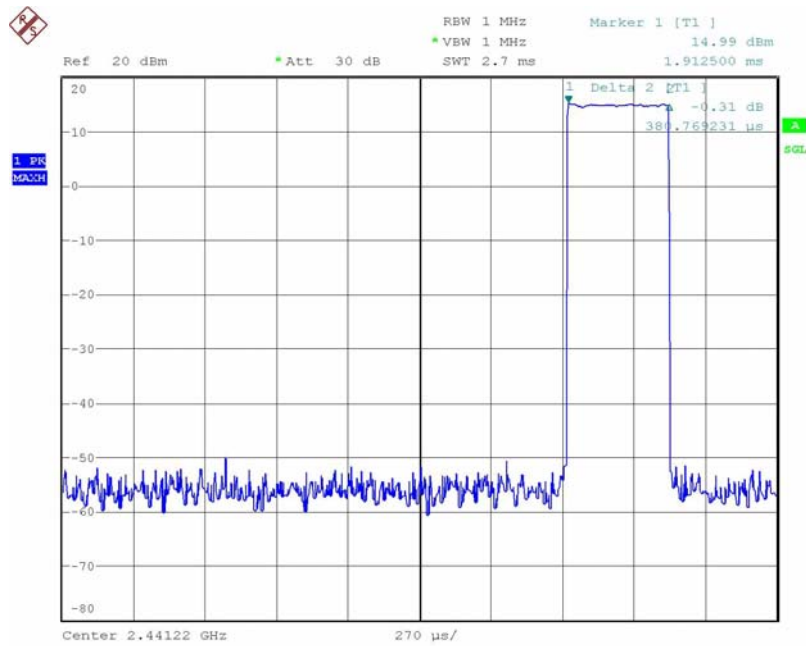

Date: 29.DEC.2007 21:24:26

Number of Pulses Plot on Channel 16 / 2441.22MHz

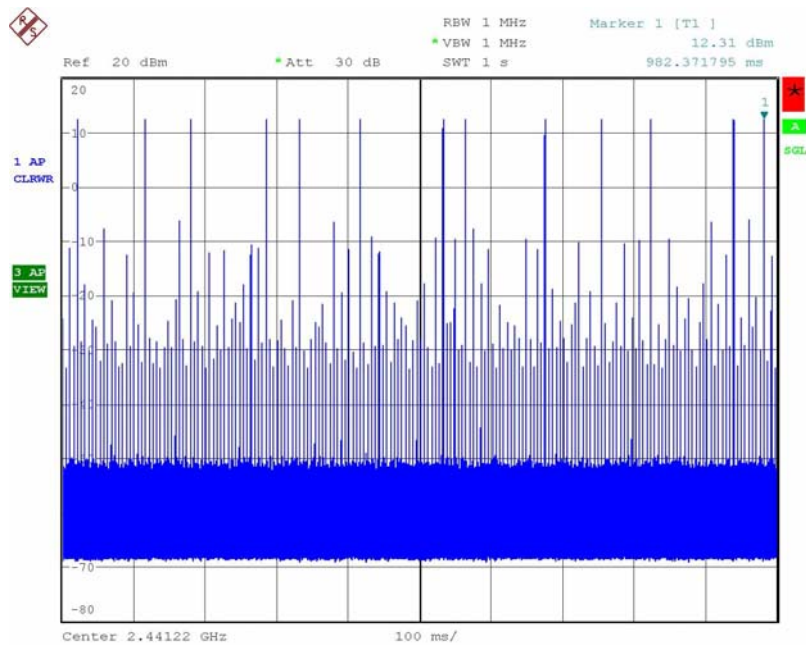

Date : 29.DEC.2007 20:53:14

Single Pulse Plot on Channel 31 / 2478.08MHz

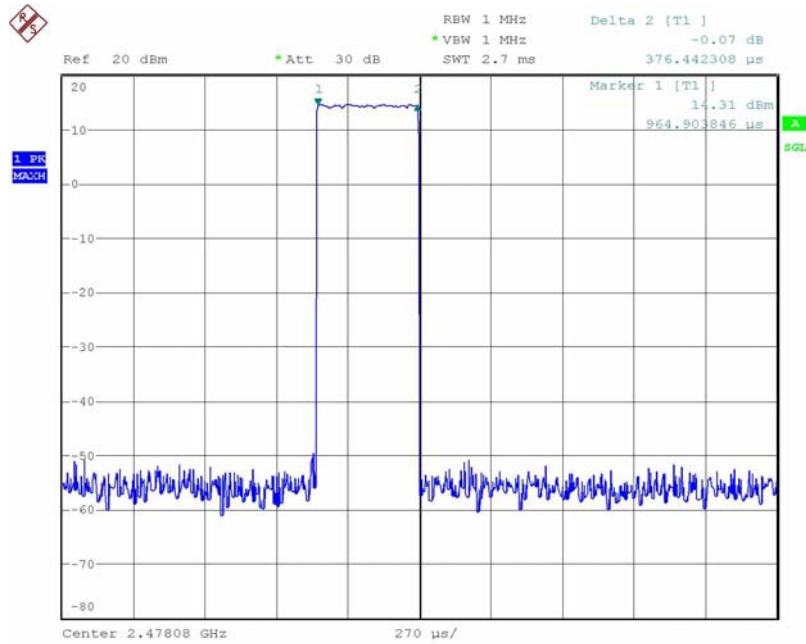

Date: 29.DEC.2007 21:34:24

Number of Pulses Plot on Channel 31 / 2478.08MHz

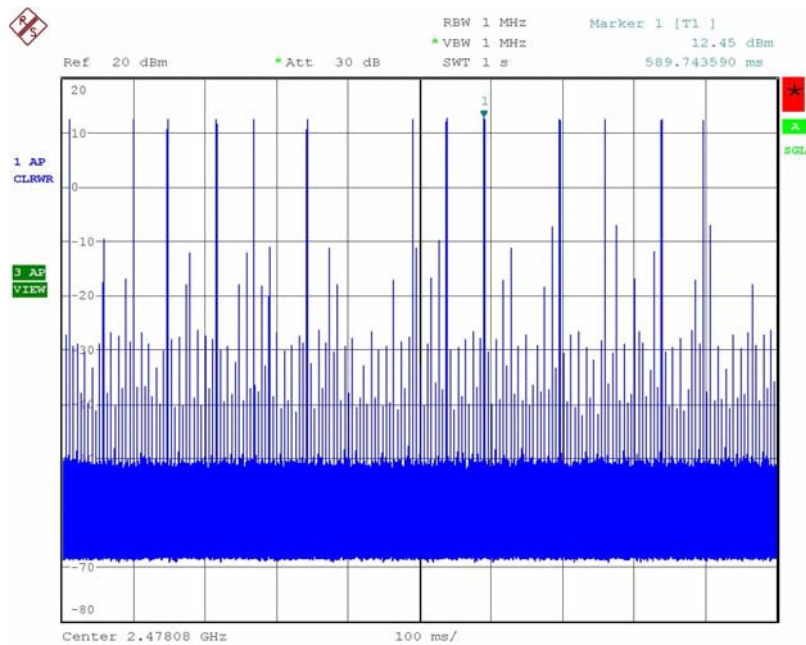

Date : 29.DEC.2007 20:55:35

4.6. Radiated Emissions Measurement

4.6.1. Limit

20dBc in any 100 kHz bandwidth outside the operating frequency band. In case the emission fall within the restricted band specified on 15.205(a), then the 15.209(a) limit in the table below has to be followed.

Frequencies (MHz)	Field Strength (microvolts/meter)	Measurement Distance (meters)
0.009~0.490	2400/F(KHz)	300
0.490~1.705	24000/F(KHz)	30
1.705~30.0	30	30
30~88	100	3
88~216	150	3
216~960	200	3
Above 960	500	3

4.6.2. Measuring Instruments and Setting

Please refer to section 5 of equipments list in this report. The following table is the setting of spectrum analyzer and receiver.

Spectrum Parameter	Setting
Attenuation	Auto
Start Frequency	1000 MHz
Stop Frequency	10th carrier harmonic
RB / VB (Emission in restricted band)	1MHz / 1MHz for Peak, 1 MHz / 10Hz for Average
RB / VB (Emission in non-restricted band)	1000KHz / 1000KHz for peak

Receiver Parameter	Setting
Attenuation	Auto
Start ~ Stop Frequency	9kHz~150kHz / RB 200Hz for QP
Start ~ Stop Frequency	150kHz~30MHz / RB 9kHz for QP
Start ~ Stop Frequency	30MHz~1000MHz / RB 120kHz for QP

4.6.3. Test Procedures

1. Configure the EUT according to ANSI C63.4. The EUT was placed on the top of the turntable 0.8 meter above ground. The phase center of the receiving antenna mounted on the top of a height-variable antenna tower was placed 3 meters far away from the turntable.
2. Power on the EUT and all the supporting units. The turntable was rotated by 360 degrees to determine the position of the highest radiation.
3. The height of the broadband receiving antenna was varied between one meter and four meters above ground to find the maximum emissions field strength of both horizontal and vertical polarization.
4. For each suspected emissions, the antenna tower was scan (from 1 M to 4 M) and then the turntable was rotated (from 0 degree to 360 degrees) to find the maximum reading.
5. Set the test-receiver system to Peak or CISPR quasi-peak Detect Function with specified bandwidth under Maximum Hold Mode.
6. For emissions above 1GHz, use 1MHz VBW and RBW for peak reading. Then 1MHz RBW and 10Hz VBW for average reading in spectrum analyzer.
7. When the radiated emissions limits are expressed in terms of the average value of the emissions, and pulsed operation is employed, the measurement field strength shall be determined by averaging over one complete pulse train, including blanking intervals, as long as the pulse train does not exceed 0.1 seconds. As an alternative (provided the transmitter operates for longer than 0.1 seconds) or in cases where the pulse train exceeds 0.1 seconds, the measured field strength shall be determined from the average absolute voltage during a 0.1 second interval during which the field strength is at its maximum value.
8. If the emissions level of the EUT in peak mode was 3 dB lower than the average limit specified, then testing will be stopped and peak values of EUT will be reported, otherwise, the emissions which do not have 3 dB margin will be repeated one by one using the quasi-peak method for below 1GHz.
9. For testing above 1GHz, the emissions level of the EUT in peak mode was lower than average limit (that means the emissions level in peak mode also complies with the limit in average mode), then testing will be stopped and peak values of EUT will be reported, otherwise, the emissions will be measured in average mode again and reported.
10. In case the emission is lower than 30MHz, loop antenna has to be used for measurement and the recorded data should be QP measured by receiver. High – Low scan is not required in this case.

4.6.4. Test Setup Layout

For radiated emissions below 30MHz

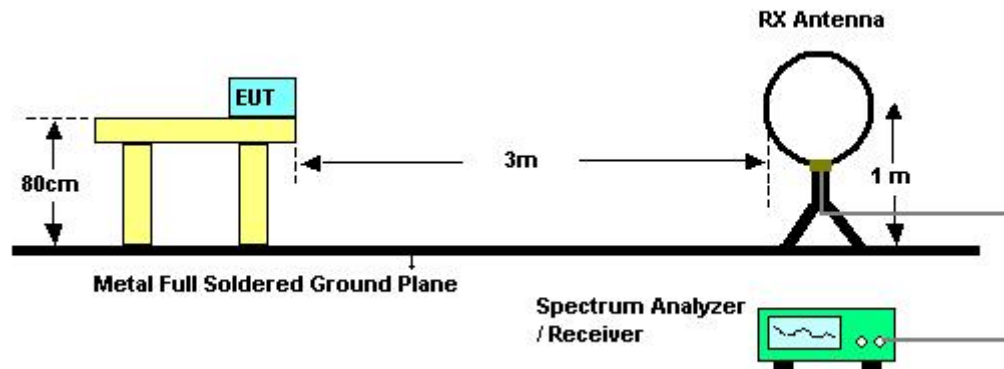

For radiated emissions above 30MHz

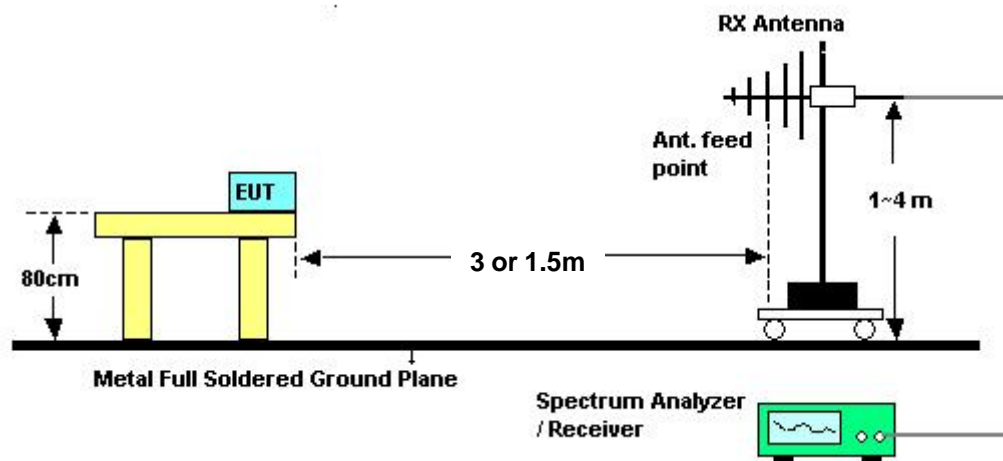

Above 10 GHz shall be extrapolated to the specified distance using an extrapolation factor of 20 dB/decade from 3m to 1.5m.

Distance extrapolation factor = $20 \log (\text{specific distance [3m]} / \text{test distance [1.5m]})$ (dB);

Limit line = specific limits (dBuV) + distance extrapolation factor [6 dB].

4.6.5. Test Deviation

There is no deviation with the original standard.

4.6.6. EUT Operation during Test

The EUT was programmed to be in continuously transmitting mode.

4.6.7. Results of Radiated Emissions (9kHz~30MHz)

Temperature	24°C	Humidity	61%
Test Engineer	Sam Chen		

Freq. (MHz)	Level (dBuV)	Over Limit (dB)	Limit Line (dBuV)	Remark
-	-	-	-	See Note

Note:

The amplitude of spurious emissions which are attenuated by more than 20dB below the permissible value has no need to be reported.

Distance extrapolation factor = $40 \log(\text{specific distance} / \text{test distance})$ (dB);

Limit line = specific limits (dBuV) + distance extrapolation factor.

4.6.8. Results of Radiated Emissions (30MHz~1GHz)

Temperature	24°C	Humidity	61%
Test Engineer	Sam Chen	Configurations	Normal Link

Horizontal

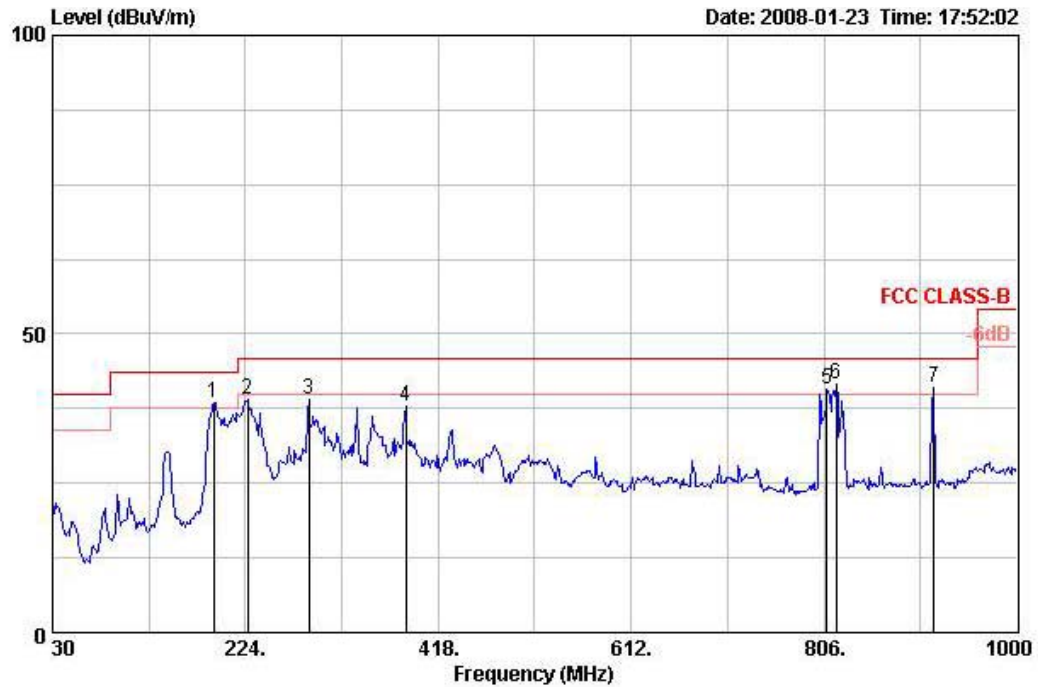

	Freq	Level	Over Limit	Limit Line	Read Level	Antenna Factor	Preamp Factor	Cable Loss	Remark	Table Pos	Ant Pos	Pol/Phase
	MHz	dBUV/m	dB	dBUV/m	dBuV	dB/m	dB	dB		deg	cm	
1 !	191.990	38.56	-4.94	43.50	55.38	8.66	27.14	1.66	Peak	0	100	HORIZONTAL
2	225.940	39.12	-6.88	46.00	55.20	9.16	27.05	1.80	Peak	0	100	HORIZONTAL
3	288.020	39.17	-6.83	46.00	51.47	12.58	26.93	2.05	Peak	0	100	HORIZONTAL
4	385.020	38.03	-7.97	46.00	48.08	15.18	27.49	2.27	Peak	0	100	HORIZONTAL
5 !	808.910	40.74	-5.26	46.00	44.70	20.31	27.58	3.32	Peak	0	100	HORIZONTAL
6 ☺	818.610	41.46	-4.54	46.00	45.29	20.40	27.56	3.34	Peak	0	100	HORIZONTAL
7 !	916.580	41.12	-4.88	46.00	44.59	20.26	27.33	3.60	Peak	0	100	HORIZONTAL

Vertical

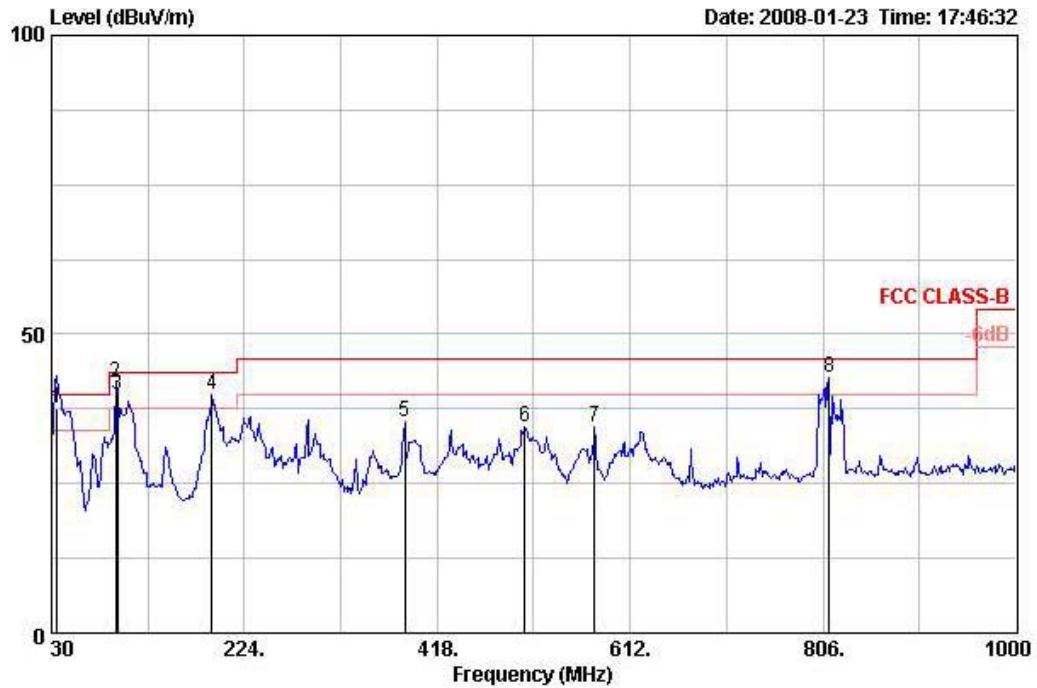

	Freq	Level	Over	Limit	Read	Antenna	Preamp	Cable	Table	Ant
	MHz	dBUV/m	Limit	Line	Level	Factor	Factor	Loss	Pos	Pos
			dB	dBUV/m	dBuV	dB/m	dB	dB	deg	cm
1 !	35.890	37.74	-2.26	40.00	50.50	14.50	27.80	0.54	104	100
2 @	94.990	41.78	-1.72	43.50	58.70	9.60	27.62	1.10	0	400
3 !	96.000	40.00	-3.50	43.50	56.70	9.80	27.62	1.12	272	100
4 !	191.020	39.84	-3.66	43.50	56.75	8.58	27.14	1.65	0	400
5	385.020	35.29	-10.71	46.00	45.34	15.18	27.49	2.27	0	400
6	506.270	34.61	-11.39	46.00	42.69	17.31	28.10	2.71	0	400
7	576.110	34.39	-11.61	46.00	40.96	18.68	28.10	2.85	0	400
8 !	811.820	42.76	-3.24	46.00	46.65	20.36	27.58	3.32	0	400

Note:

The amplitude of spurious emissions which are attenuated by more than 20dB below the permissible value has no need to be reported.

Corrected Reading: Antenna Factor + Cable Loss + Read Level - Preamp Factor = Level.

4.6.9. Results for Radiated Emissions (1GHz~10th Harmonic)

Temperature	24°C	Humidity	61%
Test Engineer	Sam Chen	Configurations	Channel 0

Horizontal

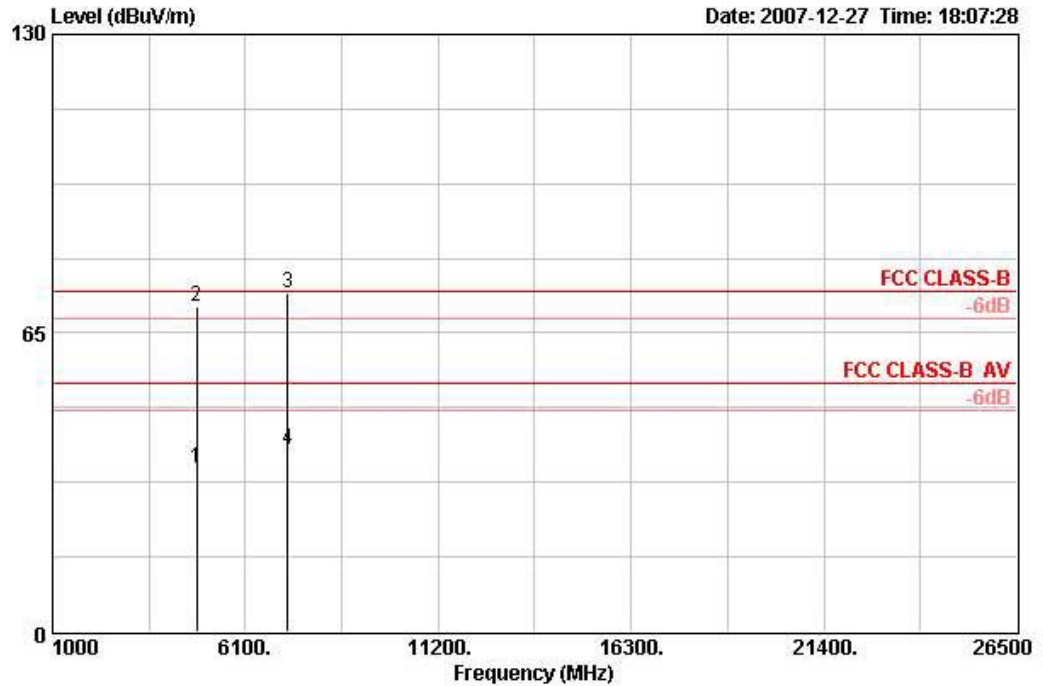

	Freq	Level	Over Limit	Limit Line	ReadAntenna Level	Antenna Factor	Cable Loss	Preamp Factor	Remark	Ant Pos	Table Pos	Pol/Phase
	MHz	dBUV/m	dB	dBUV/m	dBuV	dB/m	dB	dB		cm	deg	
1	4807.940	35.73	-18.27	54.00	31.50	33.02	6.39	35.17	AVERAGE	173	247	HORIZONTAL
2	4809.680	70.65	-3.35	74.00	66.41	33.02	6.39	35.17	PEAK	173	247	HORIZONTAL
3	7211.280	73.73	-0.27	74.00	65.87	35.71	7.36	35.21	PEAK	126	235	HORIZONTAL
4	7213.680	39.55	-14.45	54.00	31.65	35.75	7.36	35.21	AVERAGE	126	235	HORIZONTAL

Vertical

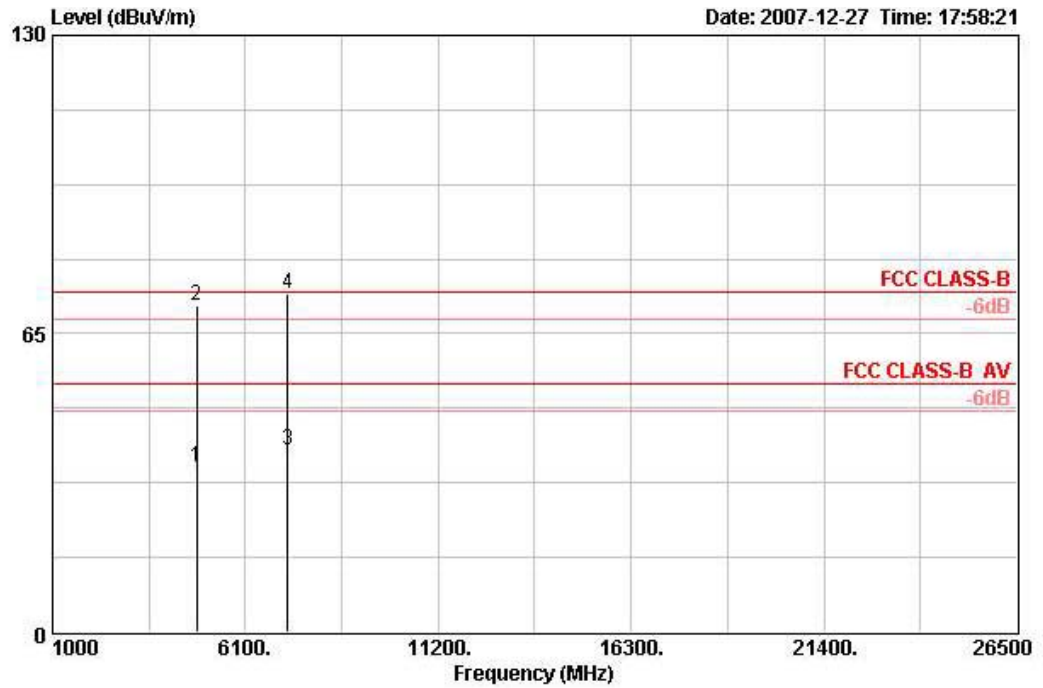

	Freq	Level	Over	Limit	Read	Antenna	Cable	Preamp	Remark	Ant	Table	
	MHz	dBuV/m	Limit	Line	Level	Factor	Loss	Factor		Pos	Pos	Pol/Phase
			dB	dBuV/m	dBuV	dB/m	dB	dB		cm	deg	
1	4807.820	35.86	-18.14	54.00	31.62	33.02	6.39	35.17	AVERAGE	100	143	VERTICAL
2	4809.680	71.08	-2.92	74.00	66.85	33.02	6.39	35.17	PEAK	100	143	VERTICAL
3	7213.620	39.57	-14.43	54.00	31.67	35.75	7.36	35.21	AVERAGE	210	282	VERTICAL
4	7214.520	73.85	-0.15	74.00	65.95	35.75	7.36	35.21	PEAK	210	282	VERTICAL

Temperature	24°C	Humidity	61%
Test Engineer	Sam Chen	Configurations	Channel 16

Horizontal

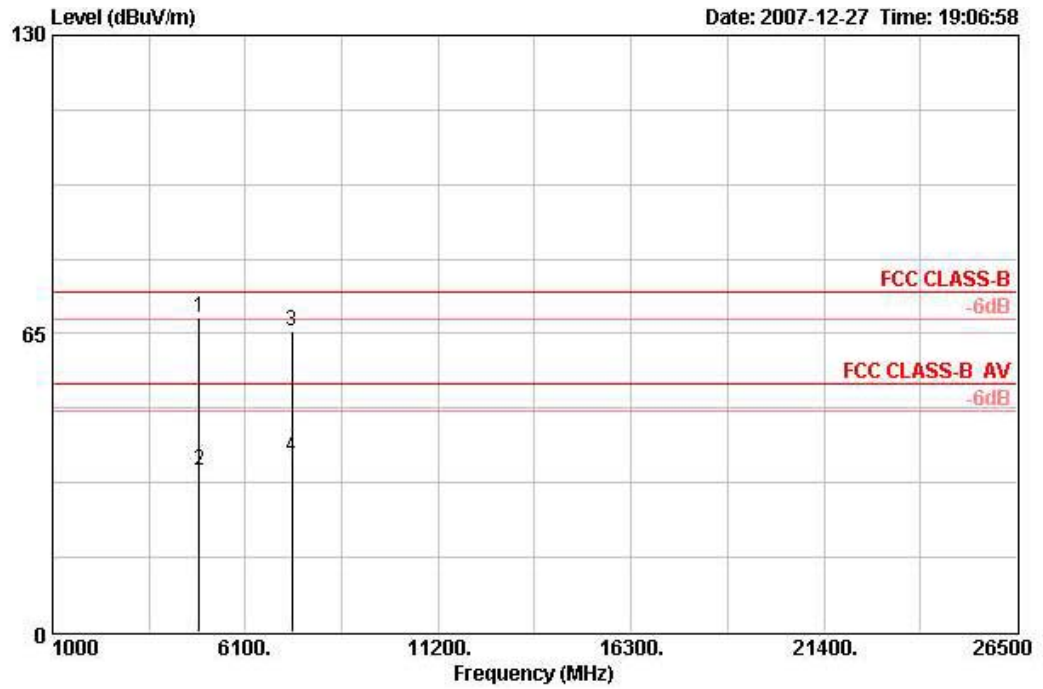

	Freq	Level	Over	Limit	ReadAntenna	Cable	Preamp	Remark	Ant	Table
	MHz	dBuV/m	dB	dBuV/m	dBuV	dB/m	dB	dB	cm	Pos Pol/Phase
1 ☺	4881.200	68.46	-5.54	74.00	64.03	33.16	6.42	35.15 PEAK	148	256 HORIZONTAL
2 ☺	4882.480	35.33	-18.67	54.00	30.90	33.16	6.42	35.15 AVERAGE	148	256 HORIZONTAL
3 ☺	7321.820	65.43	-8.57	74.00	57.31	35.96	7.35	35.18 PEAK	185	282 HORIZONTAL
4 ☺	7324.260	38.09	-15.91	54.00	29.96	35.96	7.35	35.18 AVERAGE	185	282 HORIZONTAL

Vertical

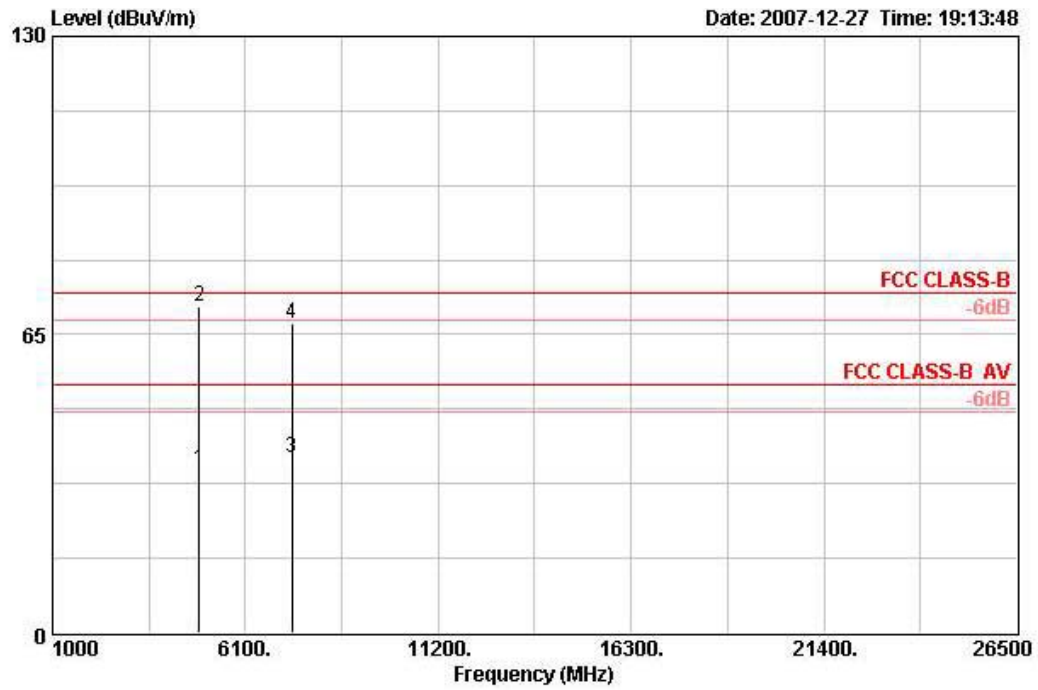

	Freq	Level	Over Limit	Limit Line	Read Level	Antenna Factor	Cable Loss	Preamp Factor	Remark	Ant Pos	Table Pos	Pol/Phase
	MHz	dBuV/m	dB	dBuV/m	dBuV	dB/m	dB	dB		cm	deg	
1	4882.980	35.54	-18.46	54.00	31.12	33.16	6.42	35.15	AVERAGE	115	0	VERTICAL
2	4883.460	70.98	-3.02	74.00	66.55	33.16	6.42	35.15	PEAK	115	0	VERTICAL
3	7324.420	38.25	-15.75	54.00	30.13	35.96	7.35	35.18	AVERAGE	180	283	VERTICAL
4	7325.100	67.36	-6.64	74.00	59.23	35.96	7.35	35.18	PEAK	180	283	VERTICAL

Temperature	24°C	Humidity	61%
Test Engineer	Sam Chen	Configurations	Channel 31

Horizontal

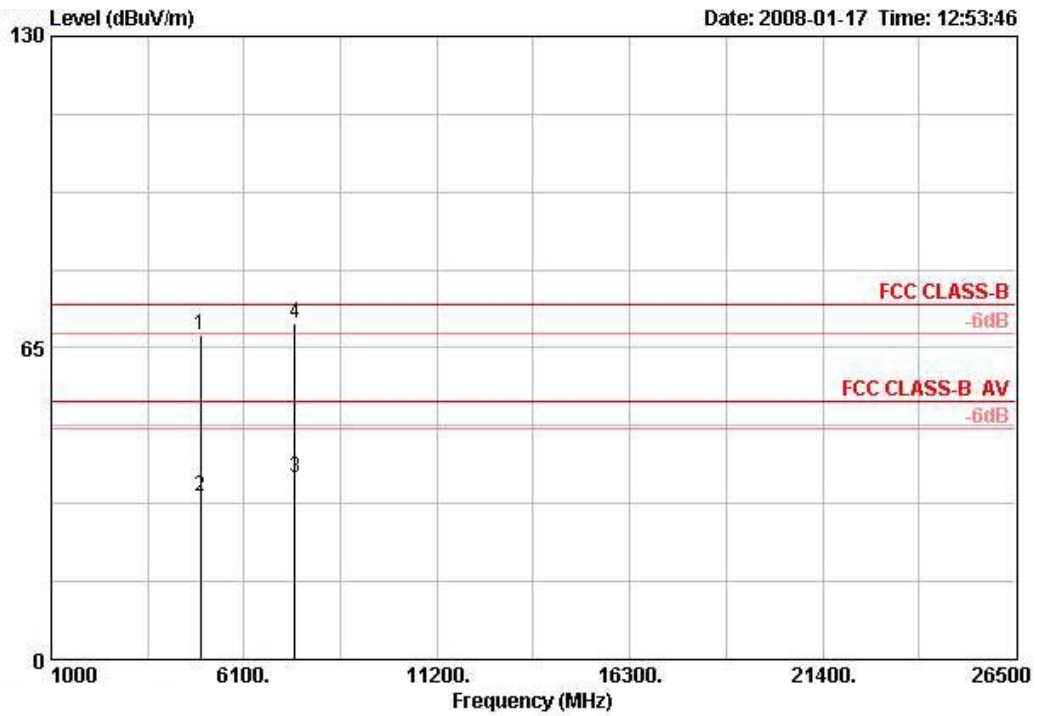

	Freq	Level	Over Limit	Limit Line	Read Level	Antenna Factor	Cable Loss	Preamp Factor	Remark	Ant Pos	Table Pos	Pol/Phase
	MHz	dBUV/m	dB	dBUV/m	dBuV	dB/m	dB	dB		cm	deg	
1	4955.040	67.54	-6.46	74.00	64.34	33.64	4.80	35.24	PEAK	154	152	HORIZONTAL
2	4956.180	34.16	-19.84	54.00	30.96	33.64	4.80	35.24	AVERAGE	154	152	HORIZONTAL
3	7434.660	37.96	-16.04	54.00	30.86	36.72	6.12	35.72	AVERAGE	118	232	HORIZONTAL
4 @	7435.680	70.12	-3.88	74.00	63.02	36.72	6.12	35.72	PEAK	118	232	HORIZONTAL

Vertical

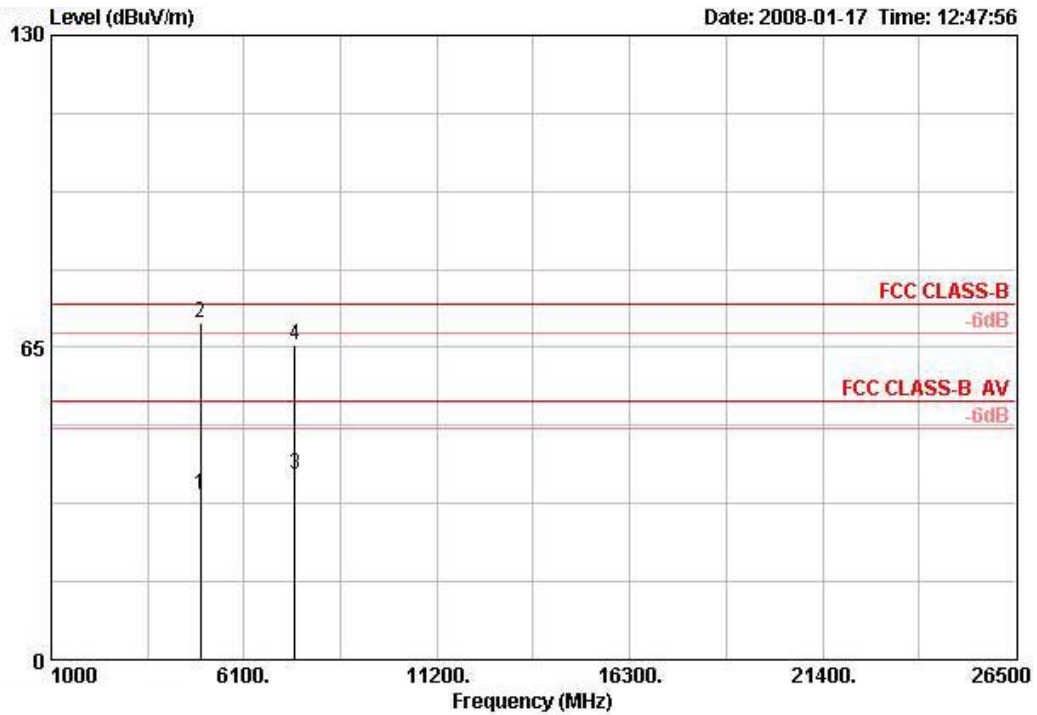

	Freq	Level	Over Limit	Limit Line	Read Level	Antenna Factor	Cable Loss	Preamp Factor	Remark	Ant Pos	Table Pos	Pol/Phase
	MHz	dBuV/m	dB	dBuV/m	dBuV	dB/m	dB	dB		cm	deg	
1	4956.180	34.27	-19.73	54.00	31.07	33.64	4.80	35.24	AVERAGE	100	197	VERTICAL
2 !	4957.200	70.03	-3.97	74.00	66.84	33.64	4.80	35.24	PEAK	100	197	VERTICAL
3	7435.080	38.70	-15.30	54.00	31.59	36.72	6.12	35.72	AVERAGE	100	277	VERTICAL
4	7435.560	65.60	-8.40	74.00	58.49	36.72	6.12	35.72	PEAK	100	277	VERTICAL

Note:

The amplitude of spurious emissions which are attenuated by more than 20dB below the permissible value has no need to be reported.

Emission level (dBUV/m) = 20 log Emission level (uV/m).

Corrected Reading: Antenna Factor + Cable Loss + Read Level - Preamp Factor = Level.

4.7. Band Edge Emissions Measurement

4.7.1. Limit

20dBc in any 100 kHz bandwidth outside the operating frequency band. In case the emission fall within the restricted band specified on 15.205(a), then the 15.209(a) limit in the table below has to be followed.

Frequencies (MHz)	Field Strength (micorvolts/meter)	Measurement Distance (meters)
0.009~0.490	2400/F(KHz)	300
0.490~1.705	24000/F(KHz)	30
1.705~30.0	30	30
30~88	100	3
88~216	150	3
216~960	200	3
Above 960	500	3

4.7.2. Measuring Instruments and Setting

Please refer to section 5 of equipments list in this report. The following table is the setting of the spectrum analyzer.

Spectrum Parameter	Setting
Attenuation	Auto
Span Frequency	100 MHz
RB / VB (Emission in restricted band)	1 MHz / 1MHz for Peak, 1 MHz / 10Hz for Average
RB / VB (Emission in non-restricted band)	100 KHz /100 KHz for Peak

4.7.3. Test Procedures

1. The test procedure is the same as section 4.5.3, only the frequency range investigated is limited to 100MHz around bandedges.
2. In case the emission is fail due to the used RB/VB is too wide, marker-delta method of FCC Public Notice DA00-705 will be followed.

4.7.4. Test Setup Layout

This test setup layout is the same as that shown in section 4.6.4.

4.7.5. Test Deviation

There is no deviation with the original standard.

4.7.6. EUT Operation during Test

The EUT was programmed to be in continuously transmitting mode.

4.7.7. Test Result of Band Edge and Fundamental Emissions

Temperature	24°C	Humidity	61%
Test Engineer	Sam Chen	Configurations	Channel 0, 16, 31

Channel 0

	Freq	Level	Over Limit	Limit Line	ReadAntenna Level	Antenna Factor	Cable Loss	Preamp Factor	Remark	Ant Pos	Table Pos	Pol/Phase
	MHz	dBuV/m	dB	dBuV/m	dBuV	dB/m	dB	dB		cm	deg	
1 ☺	2389.220	56.51	-17.49	74.00	24.21	28.17	4.13	0.00	PEAK	179	360	VERTICAL
2	2389.220	7.27	-46.73	54.00	-25.03	28.17	4.13	0.00	Average	179	360	VERTICAL
3 ☺	2403.760	105.81			73.45	28.21	4.15	0.00	PEAK	179	360	VERTICAL
4 ☺	2404.360	49.41			17.05	28.21	4.15	0.00	AVERAGE	179	360	VERTICAL

Item 3, 4 are the fundamental frequency at 2404.35 MHz.

Channel 39

	Freq	Level	Over Limit	Limit Line	ReadAntenna Level	Antenna Factor	Cable Loss	Preamp Factor	Remark	Ant Pos	Table Pos	Pol/Phase
	MHz	dBuV/m	dB	dBuV/m	dBuV	dB/m	dB	dB		cm	deg	
1 ☺	2441.360	49.49			17.00	28.29	4.20	0.00	AVERAGE	100	18	VERTICAL
2 ☺	2441.660	105.47			72.98	28.29	4.20	0.00	PEAK	100	18	VERTICAL

Item 1, 2 are the fundamental frequency at 2441.22 MHz.

Channel 78

	Freq	Level	Over Limit	Limit Line	ReadAntenna Level	Antenna Factor	Cable Loss	Preamp Factor	Remark	Ant Pos	Table Pos	Pol/Phase
	MHz	dBuV/m	dB	dBuV/m	dBuV	dB/m	dB	dB		cm	deg	
1 ☺	2478.000	49.64			17.05	28.36	4.23	0.00	AVERAGE	165	360	VERTICAL
2 ☺	2478.600	105.56			72.97	28.36	4.23	0.00	PEAK	165	360	VERTICAL
3 ☺	2483.500	66.11	-7.89	74.00	33.52	28.36	4.23	0.00	Peak	165	360	VERTICAL
4	2483.500	10.24	-43.76	54.00	-22.35	28.36	4.23	0.00	AVERAGE	165	360	VERTICAL

Item 1, 2 are the fundamental frequency at 2478.08 MHz.

Note:

Emission level (dBuV/m) = 20 log Emission level (uV/m).

Corrected Reading: Antenna Factor + Cable Loss + Read Level - Preamp Factor = Level.

For Emission not in Restricted Band

Low Band Edge Plot on Channel 0 / 2404.35MHz

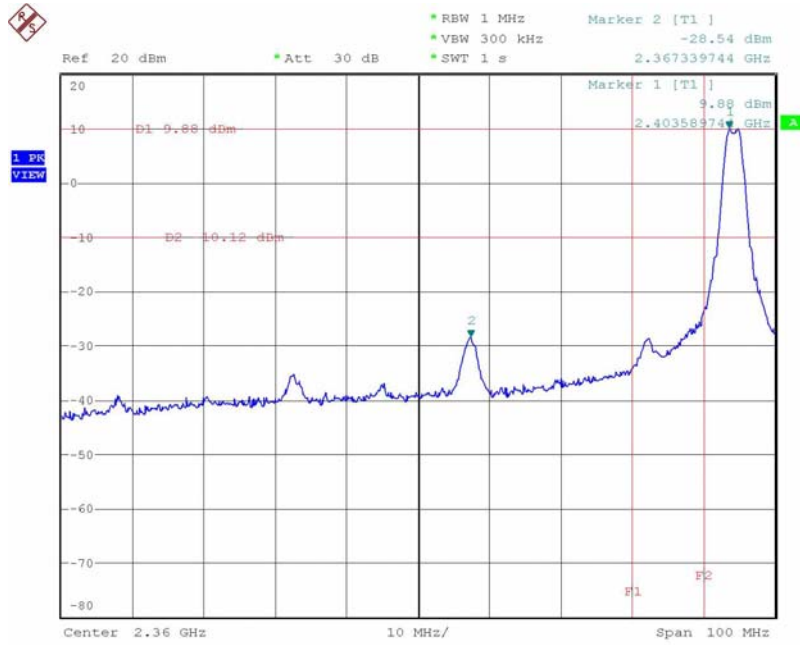

Date: 29.DEC.2007 21:15:25

High Band Edge Plot on Channel 31 / 2478.08MHz

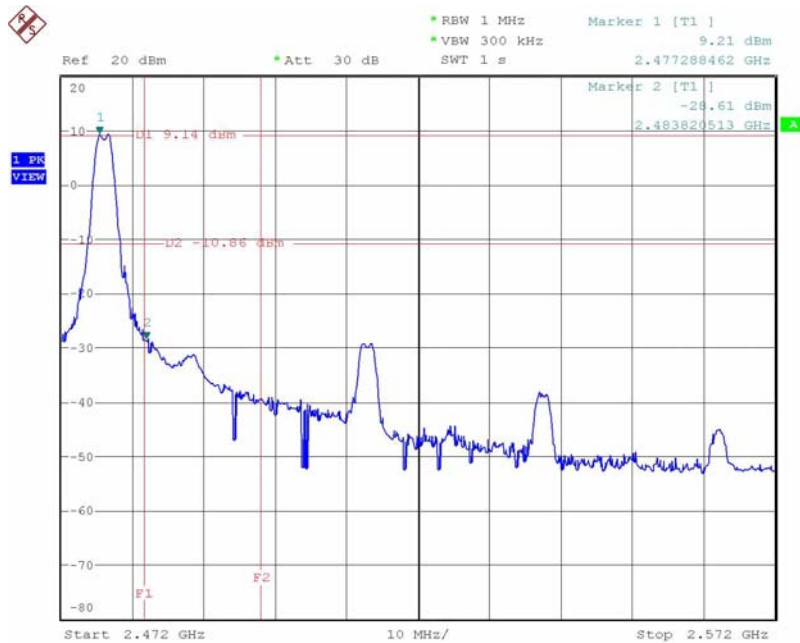

Date: 29.DEC.2007 21:36:42

4.8. Antenna Requirements

4.8.1. Limit

Except for special regulations, the Low-power Radio-frequency Devices must not be equipped with any jacket for installing an antenna with extension cable. An intentional radiator shall be designed to ensure that no antenna other than that furnished by the responsible party shall be used with the device. The use of a permanently attached antenna or of an antenna that uses a unique coupling to the intentional radiator shall be considered sufficient to comply with the provisions of this Section. The manufacturer may design the unit so that the user can replace a broken antenna, but the use of a standard antenna jack or electrical connector is prohibited. Further, this requirement does not apply to intentional radiators that must be professionally installed.

4.8.2. Antenna Connector Construction

Please refer to section 3.3 in this test report, antenna connector complied with the requirements.

5. LIST OF MEASURING EQUIPMENTS

Instrument	Manufacturer	Model No.	Serial No.	Characteristics	Calibration Date	Remark
EMC Receiver	R&S	ESCS 30	100174	9kHz – 2.75GHz	Mar. 03, 2007	Conduction (CO04-HY)
LISN	MessTec	NNB-2/16Z	99079	9kHz – 30MHz	Mar. 31, 2007	Conduction (CO04-HY)
LISN (Support Unit)	EMCO	3810/2NM	9703-1839	9kHz – 30MHz	Mar. 22, 2007	Conduction (CO04-HY)
RF Cable-CON	UTIFLEX	3102-26886-4	CB049	9kHz – 30MHz	Apr. 20, 2007	Conduction (CO04-HY)
ISN	SCHAFFNER	ISN T400	21653	9kHz – 30MHz	Mar. 27, 2007	Conduction (CO04-HY)
EMI Filter	LINDGREN	LRE-2030	2651	< 450 Hz	N/A	Conduction (CO04-HY)
3m Semi Anechoic Chamber	SIDT FRANKONIA	SAC-3M	03CH03-HY	30 MHz - 1 GHz 3m	Jun. 14, 2007	Radiation (03CH03-HY)
Amplifier	SCHAFFNER	CPA9231A	1886	9 kHz - 2 GHz	Jan. 22, 2007	Radiation (03CH03-HY)
Amplifier	SCHAFFNER	COA9231A	18667	9 kHz - 2 GHz	Jan. 14, 2008	Radiation (03CH03-HY)
Amplifier	Agilent	8449B	3008A02120	1 GHz - 26.5 GHz	Jun. 07, 2007	Radiation (03CH03-HY)
Amplifier	MITEQ	AMF-6F-260400	9121372	26.5 GHz - 40 GHz	Jan. 22, 2007*	Radiation (03CH03-HY)
Spectrum Analyzer	R&S	FSP40	100305	9 kHz - 40 GHz	Sep. 27, 2007	Radiation (03CH03-HY)
Loop Antenna	R&S	HFH2-Z2	860004/001	9 kHz - 30 MHz	May 23, 2006*	Radiation (03CH03-HY)
Bilog Antenna	SCHAFFNER	CBL 6112D	22237	30 MHz – 1 GHz	Jul. 21, 2007	Radiation (03CH03-HY)
Horn Antenna	EMCO	3115	6741	1GHz ~ 18GHz	May 04, 2007	Radiation (03CH03-HY)
Horn Antenna	SCHWARZBECK	BBHA9170	BBHA9170154	15 GHz - 40 GHz	NCR	Radiation (03CH03-HY)
RF Cable-R03m	Jye Bao	RG142	CB021	30 MHz - 1 GHz	Dec. 03, 2007	Radiation (03CH03-HY)
RF Cable-HIGH	SUHNER	SUCOFLEX 106	03CH03-HY	1 GHz - 40 GHz	Dec. 03, 2007	Radiation (03CH03-HY)
Turn Table	HD	DS 420	420/650/00	0 – 360 degree	N/A	Radiation (03CH03-HY)
Antenna Mast	HD	MA 240	240/560/00	1 m - 4 m	N/A	Radiation (03CH03-HY)
Spectrum Analyzer	R&S	FSP30	100023	9kHz ~ 30GHz	Dec. 17, 2007	Conducted (TH01-HY)
Power Meter	R&S	NRVS	100444	DC ~ 40GHz	Jun. 27, 2007	Conducted (TH01-HY)
Power Sensor	R&S	NRV-Z51	100458	DC ~ 30GHz	Jun. 27, 2007	Conducted (TH01-HY)
Power Sensor	R&S	NRV-Z32	100057	30MHz ~ 6GHz	Jun. 27, 2007	Conducted (TH01-HY)
AC Power Source	HPC	HPA-500W	HPA-9100024	AC 0 ~ 300V	May 04, 2007*	Conducted (TH01-HY)
DC Power Source	G.W.	GPC-6030D	C671845	DC 1V ~ 60V	Mar. 03, 2007	Conducted (TH01-HY)
Temp. and Humidity Chamber	KSON	THS-C3L	612	N/A	Oct. 01, 2007	Conducted (TH01-HY)
RF CABLE-1m	Jye Bao	RG142	CB034-1m	20MHz ~ 7GHz	Dec. 01, 2007	Conducted (TH01-HY)
RF CABLE-2m	Jye Bao	RG142	CB035-2m	20MHz ~ 1GHz	Dec. 01, 2007	Conducted (TH01-HY)
Vector Signal Generator	R&S	SMU200A	102098	100kHz ~ 6GHz	Nov. 14, 2007	Conducted (TH01-HY)
Signal Generator	R&S	SMR40	100116	10MHz ~ 40GHz	Mar. 07, 2007	Conducted (TH01-HY)



Note: Calibration Interval of instruments listed above is one year.

Note: *Calibration Interval of instruments listed above is two year.

6. TEST LOCATION

SHIJR	ADD : 6Fl., No. 106, Sec. 1, Shintai 5th Rd., Shijr City, Taipei, Taiwan 221, R.O.C. TEL : 886-2-2696-2468 FAX : 886-2-2696-2255
HWA YA	ADD : No. 52, Hwa Ya 1st Rd., Kwei-Shan Hsiang, Tao Yuan Hsien, Taiwan, R.O.C. TEL : 886-3-327-3456 FAX : 886-3-318-0055
LINKOU	ADD : No. 30-2, Dingfu Tsuen, Linkou Shiang, Taipei, Taiwan 244, R.O.C TEL : 886-2-2601-1640 FAX : 886-2-2601-1695
DUNGHU	ADD : No. 3, Lane 238, Kangle St., Neihu Chiu, Taipei, Taiwan 114, R.O.C. TEL : 886-2-2631-4739 FAX : 886-2-2631-9740
JUNGHE	ADD : 7Fl., No. 758, Jungjeng Rd., Junghe City, Taipei, Taiwan 235, R.O.C. TEL : 886-2-8227-2020 FAX : 886-2-8227-2626
NEIHU	ADD : 4Fl., No. 339, Hsin Hu 2 nd Rd., Taipei 114, Taiwan, R.O.C. TEL : 886-2-2794-8886 FAX : 886-2-2794-9777
JHUBEI	ADD : No.8, Lane 728, Bo-ai St., Jhubei City, HsinChu County 302, Taiwan, R.O.C. TEL : 886-3-656-9065 FAX : 886-3-656-9085

7. TAF CERTIFICATE OF ACCREDITATION



Certificate No. : L1190-070110

財團法人全國認證基金會
Taiwan Accreditation Foundation

Certificate of Accreditation

This is to certify that

Sporton International Inc.
EMC & Wireless Communications Laboratory
No.52, Hwa Ya 1st Rd., Hwa Ya Technology Park, Kwei-Shan Hsiang, Tao Yuan Hsien,
Taiwan, R.O.C.

is accredited in respect of laboratory

Accreditation Criteria	: ISO/IEC 17025:2005
Accreditation Number	: 1190
Originally Accredited	: December 15, 2003
Effective Period	: January 10, 2007 to January 09, 2010
Accredited Scope	: Testing Field, see described in the Appendix
Specific Accreditation Program	: Accreditation Program for Designated Testing Laboratory for Commodities Inspection : Accreditation Program for Telecommunication Equipment Testing Laboratory



Jay-San Chen
President, Taiwan Accreditation Foundation
Date : January 10, 2007

PI, total 9 pages

The Appendix forms an integral part of this Certificate, which shall be invalid when used without the Appendix.