

Title <Title>		
Size A	Document Number <Doc>	Rev <RevCode>
Date: Wednesday, October 05, 2005	Sheet 1	of 1

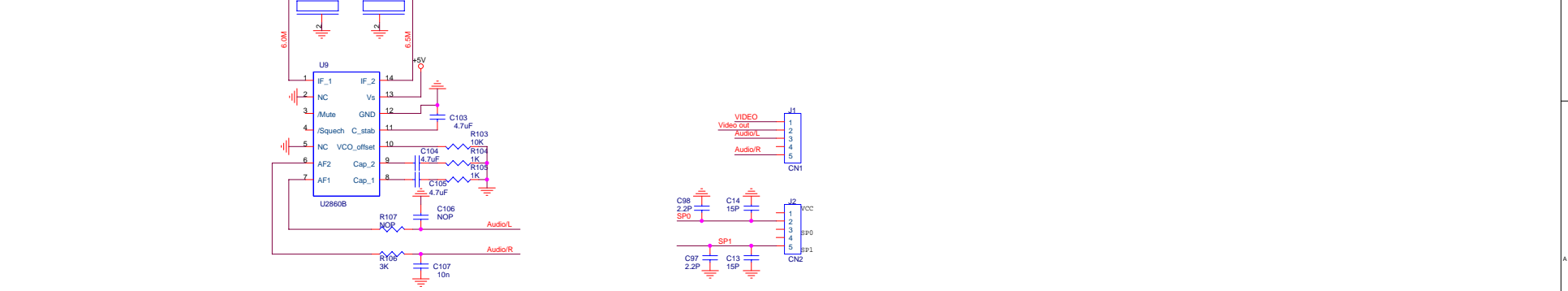

File	<Title>	Rev
Size	Document Number	<Doc>
Date	Wednesday, November 23, 2006	Sheet 1 of 1

64R
M/B_2005-09-30

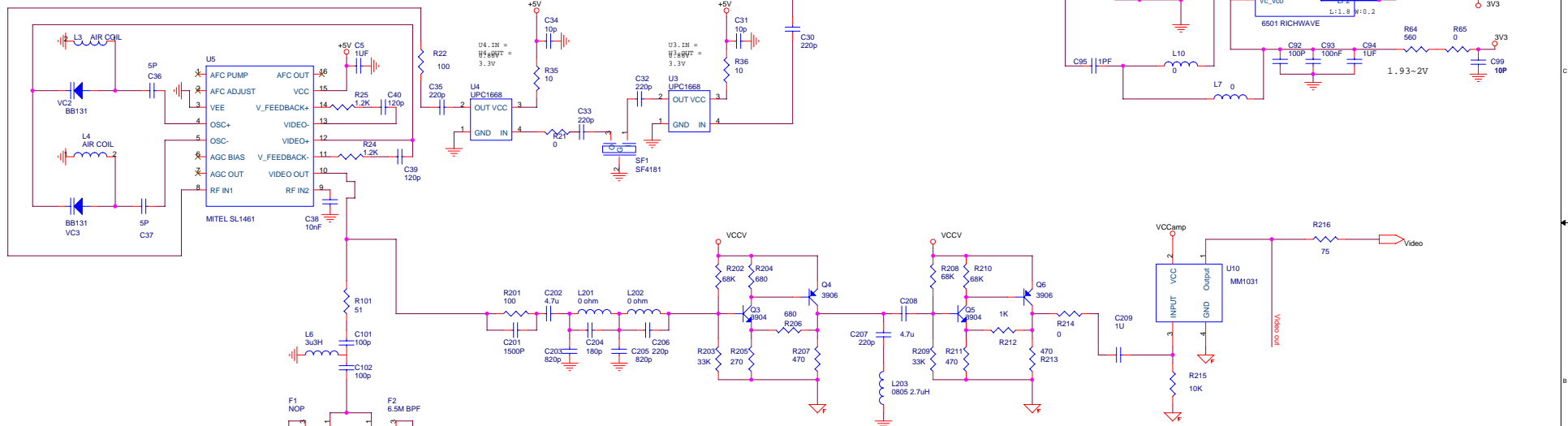
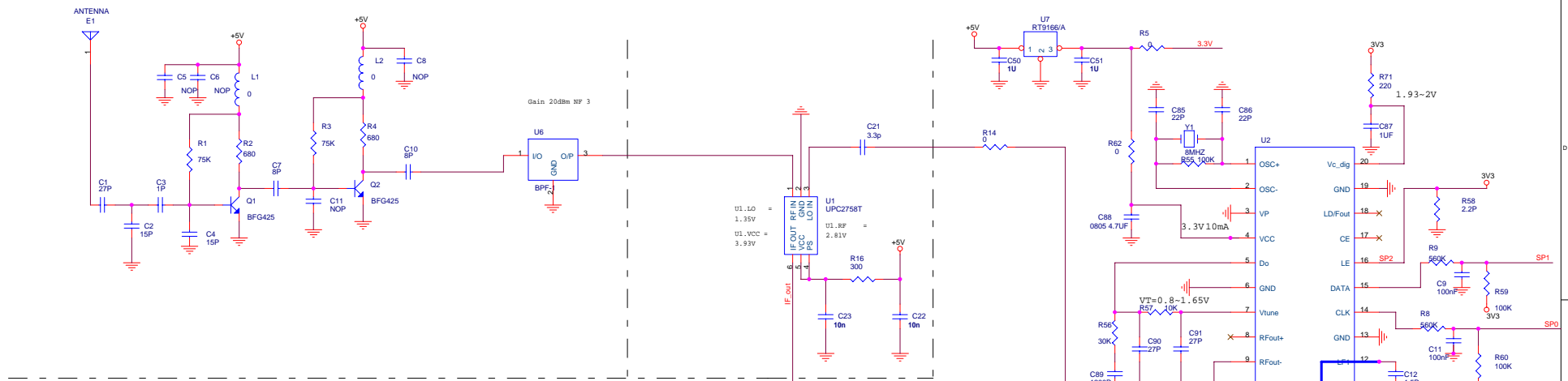
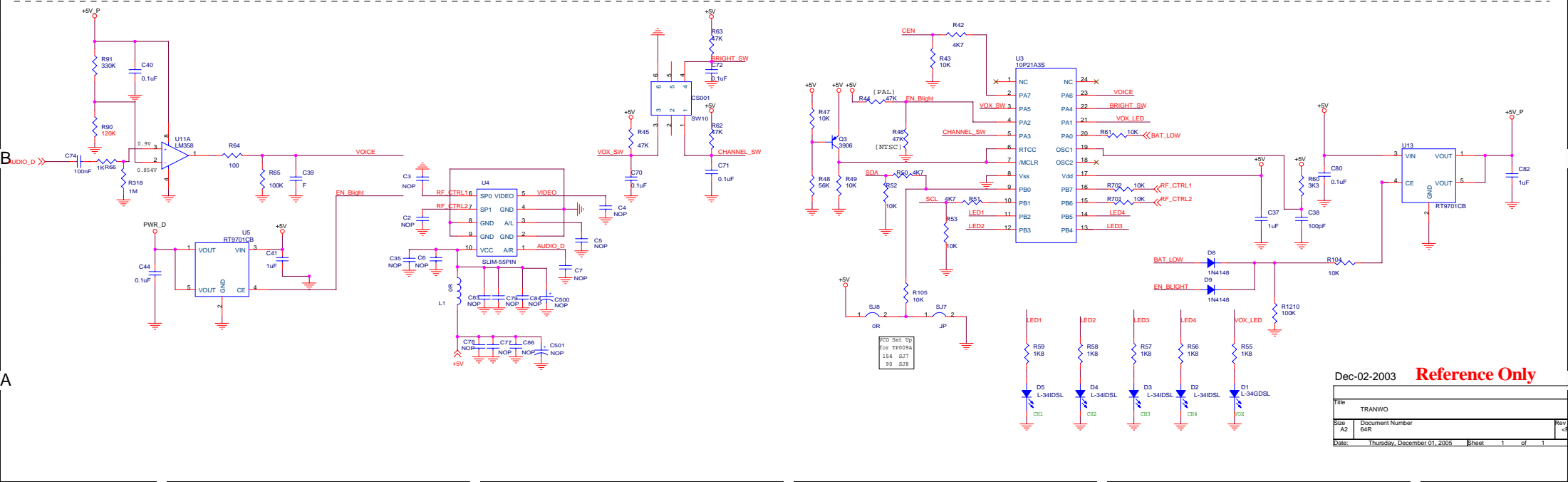
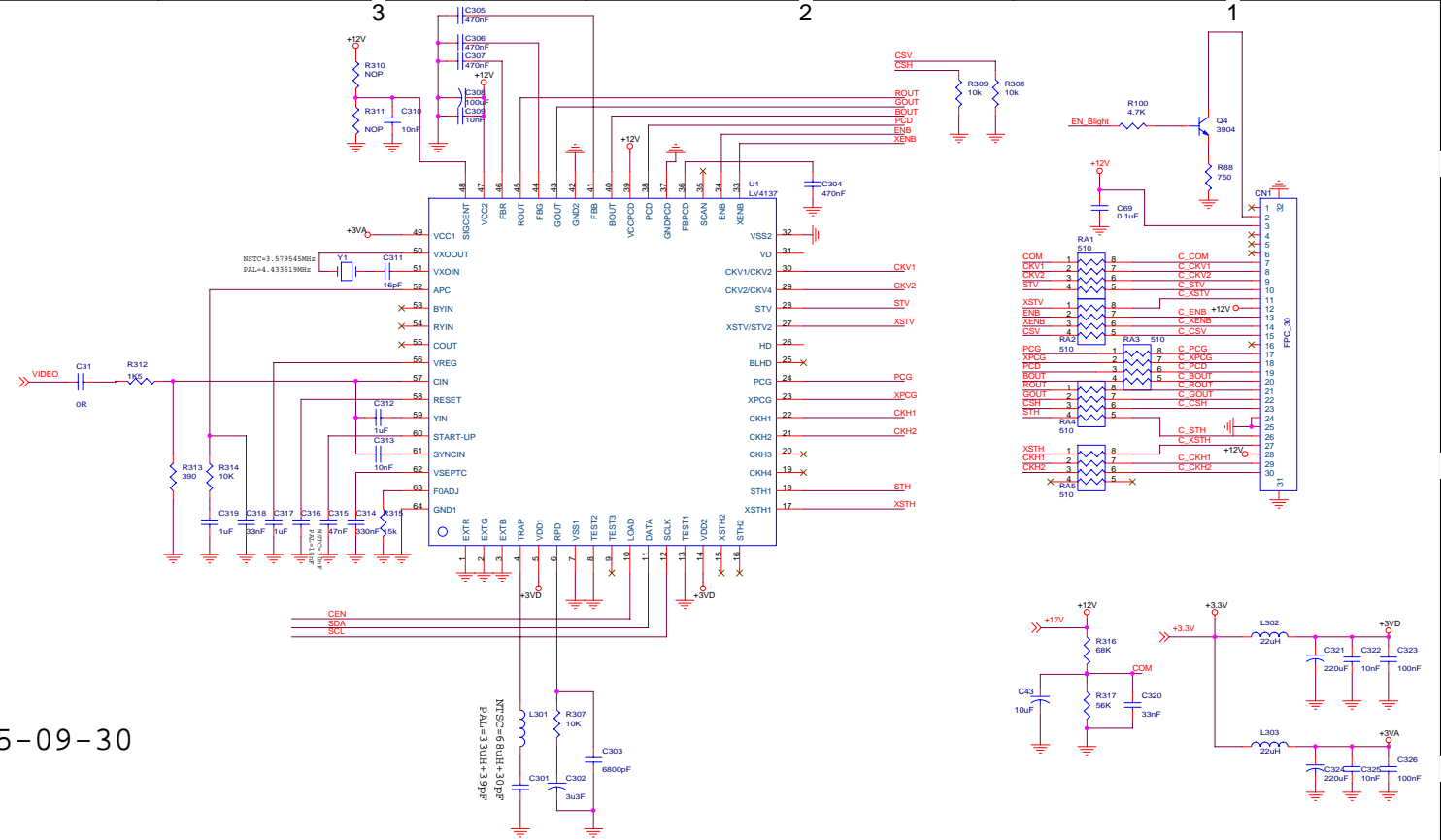

64R

M/B_2005-09-30

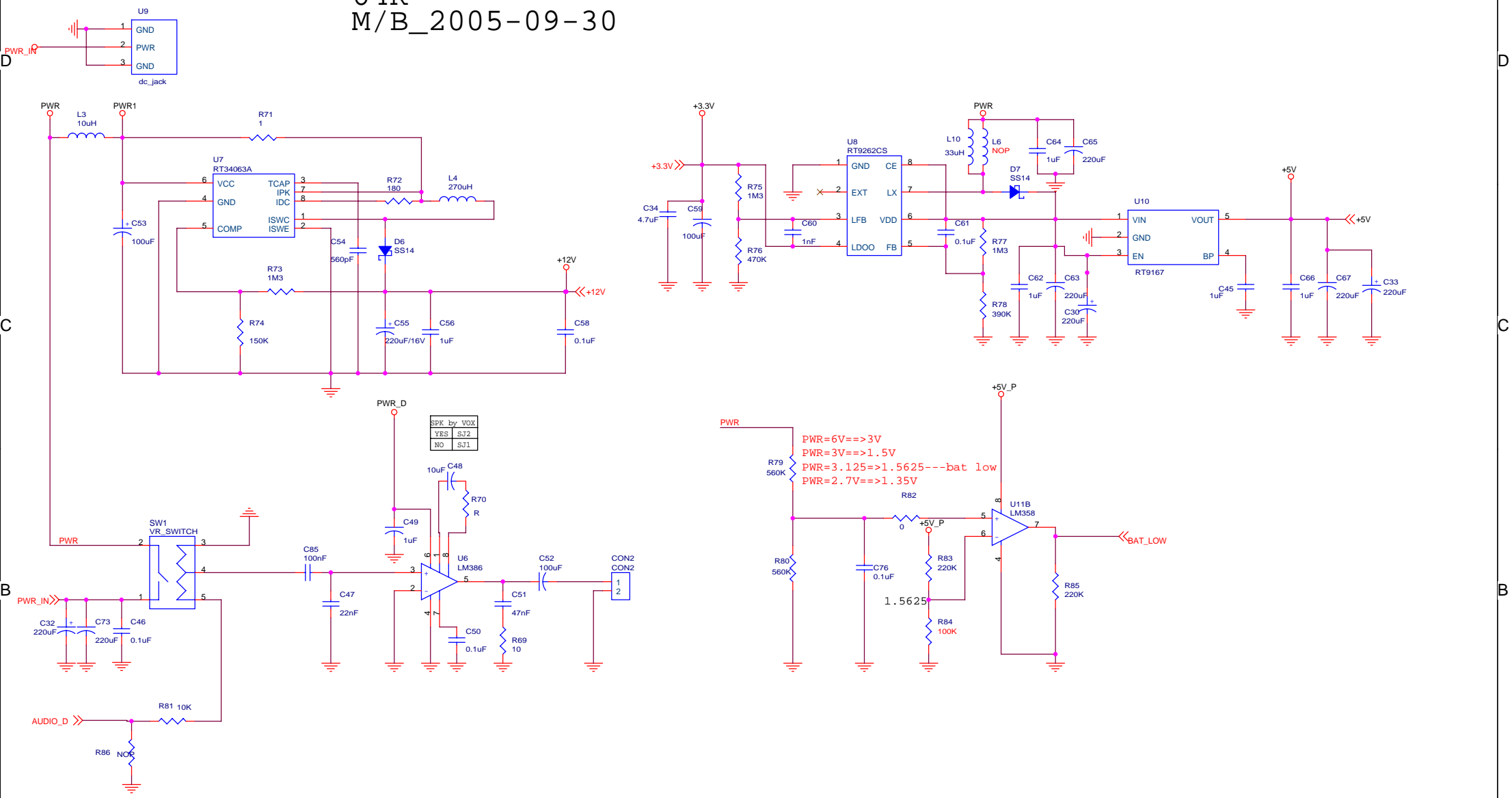

Reference Only

Title		
TRANWO		
Size	Document Number	Rev
A3	64R	<Rev Code>
Date:	Thursday, December 01, 2005	Sheet 1 of 1

