



# Test Report

For

**Applicant** : **TRANWO TECHNOLOGY CORP.**  
**Equipment Type** : **Wireless A/V Sender with Remote Control Extender**  
**Model** : **TTA-20T**  
**FCC ID** : **O6LTTA-20T**

**Report No. : 00CH003FI**



## Test Report Certification

### Quietek Corporation

No.75-1, Wang-Yeh Valley, Yung-Hsing, Chiung-Lin,  
Hsin-Chu County, Taiwan, R.O.C.

Tel : 886-3-592-8858, Fax: 886-3-592-8859

E-Mail : quietek@ms24.hinet.net

Accredited by NIST(NVLAP), VCCI, BSMI, DNV, TUV

Applicant : TRANWO TECHNOLOGY CORP.  
Address : 2F, No.45, Shian Jeng 2nd Rd., Jubei City, Hsinchu, Taiwan,  
R.O.C.  
Equipment Type : Wireless A/V Sender with Remote Control Extender  
Model : TTA-20T  
FCC ID. : O6LTTA-20T  
Measurement Standard : FCC Part 15 Subpart C Paragraph 15.249  
Measurement Procedure : ANSI C63.4 /1992  
Operation Voltage : 120VAC/60Hz  
Test Result : Complied  
Test Date : Dec 28, 2000  
Report No. : 00CH003FI



The Test Results relate only to the samples tested.  
The test report shall not be reproduced except in full without the written approval of Quietek Corporation.  
This report must not be used to claim product endorsement by NVLAP any agency of the U.S. Government

Documented by: Kim Hung

Test Engineer: Calien Kang

Approved: Kevin Wang

Handwritten signature of Kim Hung in black ink.

Handwritten signature of Calien Kang in black ink.

Handwritten signature of Kevin Wang in black ink.



# TABLE OF CONTENTS

Description	Page
<b>1. GENERAL INFORMATION .....</b>	<b>4</b>
1.1 EUT Description .....	4
1.2 Tested System Details .....	5
1.3 EUT Configuration.....	6
1.4 EUT Exercise Software .....	6
1.5 Test performed .....	6
1.6 Test Facility .....	7
<b>2. CONDUCTED EMISSION .....</b>	<b>8</b>
2.1 Test Equipment List.....	8
2.2 Test Setup.....	8
2.3 Limits .....	8
2.4 Test Procedure.....	9
2.5 Test Results.....	9
<b>3. RADIATED EMISSION.....</b>	<b>10</b>
3.1 Test Equipment .....	10
3.2 Test Setup.....	10
3.3 Limits .....	11
3.4 Test Procedure.....	12
3.5 Test Results.....	12
<b>4. EMI REDUCTION METHOD DURING COMPLIANCE TESTING.....</b>	<b>13</b>
<b>5. ATTACHMENT.....</b>	<b>14</b>
Attachment 1: Summary of Test Results	
Attachment 2: EUT Test Photographs	
Attachment 3: EUT Detailed Photographs	



# 1. General Information

## 1.1 EUT Description

Applicant	: TRANWO TECHNOLOGY CORP.
Address	: 2F, No.45, Shian Jeng 2nd Rd., Jubei City, Hsinchu, Taiwan, R.O.C.
Equipment Type	: Wireless A/V Sender with Remote Control Extender
Model	: TTA-20T
FCC ID	: O6LTTA-20T
Operation Voltage	: 120VAC/60Hz
Frequency Range	: 2411 MHz to 2473MHz
Channel Number	: 4
Frequency of each Channel	: Channel 1: 2434MHz, Channel 2: 2453MHz, Working Frequency Channel 3: 2473MHz, Channel 4: 2411MHz
Type of Modulation	: FM
Operator Selection of Operating Frequency	: Manual Switch
Extender	: Non-shielded, 1.2m
Power Adapter	: AHEAD, MW35-090030 Cable Out: Non-shielded, 1.8m

- Remark:
1. This device is a Wireless A/V Sender with Remote Control Extender included a 2.4GHz transmitting function, a 433MHz receiving function, an Audio/Video port and an IR-remote output.
  2. These tests were conducted on a sample of the equipment for the purpose of demonstrating compliance with Part 15 Subpart C Paragraph 15.249 for non-spread spectrum devices.
  3. This device is a composite device in accordance with Part 15 regulations. The function for the receiver was, measured and made a test report that the report number is 00CH003F, certified under verification.



## 1.2 Tested System Details

The types for all equipment, plus descriptions of all cables used in the tested system (including inserted cards ) are:

### 1.2.1 Wireless A/V Sender with Remote Control Extender(EUT)

Model Number : TTA-20T  
Serial Number : N/A  
FCC ID : O6LTTA-20T  
Manufacturer : TRANWO TECHNOLOGY CORP.  
Extender : Non-shielded, 1.2m  
Power Adapter : AHEAD, MW35-090030  
Cable Out: Non-shielded, 1.8m

### 1.2.2 Video Camera Recorder

Model Number : PV-7450  
Serial Number : N/A  
FCC ID : ACJ927098AH  
Manufacturer : Panasonic  
Power Cord : Non-shielded, 1.6m  
Data Cable (AV) : Non-shielded, 1m

### 1.2.3 Wireless A/V Sender with Remote Control Extender(RX)

Model Number : TTA-20R  
Serial Number : N/A  
FCC ID : DoC  
Manufacturer : TRANWO TECHNOLOGY CORP.  
RCA Cable (3-3) : Non-shielded, 1.5m  
Power Adapter : AHEAD, MW35-0900300  
Cable Out: Non-shielded, 1.8m

### 1.2.4 Monitor

Model Number : KV-14NX  
Serial Number : 103125  
BSMI ID : 3863A019  
Manufacturer : SONY  
Power Cord : Non-shielded, 1.8m



### 1.3 EUT Configuration

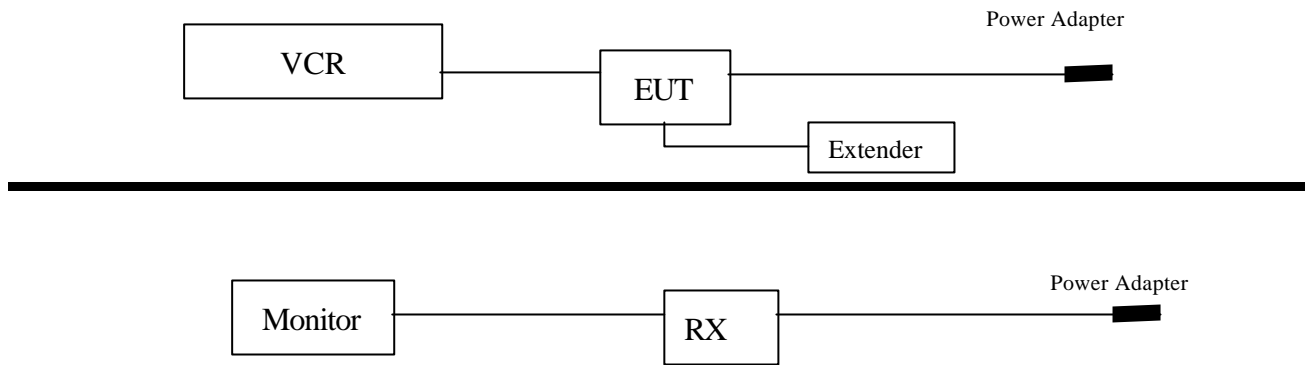

### 1.4 EUT Exercise Software

The EUT exercise program used during conducted testing was designed to exercise the EUT in a manner similar to a typical use. The exercise sequence is listed as below:

- 1.4.1 Setup the EUT and display as shown on 1.3.
- 1.4.2 Turn on the power of all equipment.
- 1.4.3 The EUT will transmit the radio signal from transmitter.
- 1.4.4 Repeat the above procedure 1.4.2 to 1.4.3

### 1.5 Test performed

Conducted emissions were investigated over the frequency range from **0.45MHz to 30MHz** using a receiver bandwidth of 9kHz.

Radiated emissions were investigated over the frequency range from **30MHz to 1000MHz** using a receiver bandwidth of 120kHz and the frequency range from **1GHz to 24GHz** using a receiver bandwidth of 1MHz.

Radiated testing was performed at an antenna to EUT distance of 3 meters.

## 1.6 Test Facility

Ambient conditions in the laboratory:

Items	Required (IEC 68-1)	Actual
Temperature (°C)	15-35	20-35
Humidity (%RH)	25-75	50-65
Barometric pressure (mbar)	860-1060	950-1000

Site Description: November 3, 1998 File on  
Federal Communications Commission  
FCC Engineering Laboratory  
7435 Oakland Mills Road  
Columbia, MD 21046  
Reference 31040/SIT1300F2



September 30, 1998 Accreditation on NVLAP  
NVLAP Lab Code: 200347-0

February 23, 1999 Accreditation on DNV  
Statement No. : 413-99-LAB11



December 8, 1998 Registration on VCCI  
Registration No. for No.2 Shielded Room C-858  
Registration No. for No.1 Open Area Test Site R-823  
Registration No. for No.2 Open Area Test Site R-835



January 04, 1999 Accreditation on TÜV Rheinland  
Certificate No.: I9865712-9901



Name of firm : QuieTek Corporation

Site location : No.75-1, Wang-Yeh Valley, Yung-Hsing Tsuen,  
Chiung-Lin, Hsin-Chu County, Taiwan, R.O.C.

## 2. Conducted Emission

### 2.1 Test Equipment List

The following test equipment are used during the conducted emission test:

Item	Instrument	Manufacturer	Type No./Serial No	Last Cal.	Remark
1	Test Receiver	R & S	ESCS 30/825442/17	May, 2000	
2	L.I.S.N.	R & S	ESH3-Z5/825016/6	May, 2000	EUT
3	L.I.S.N.	Kyoritsu	KNW-407/8-1420-3	May, 2000	Peripherals
4	Pulse Limiter	R & S	ESH3-Z2	N/A	
5	N0.2 Shielded Room			N/A	

Note: All equipment upon which need to calibrated are with calibration period of 1 year.

### 2.2 Test Setup

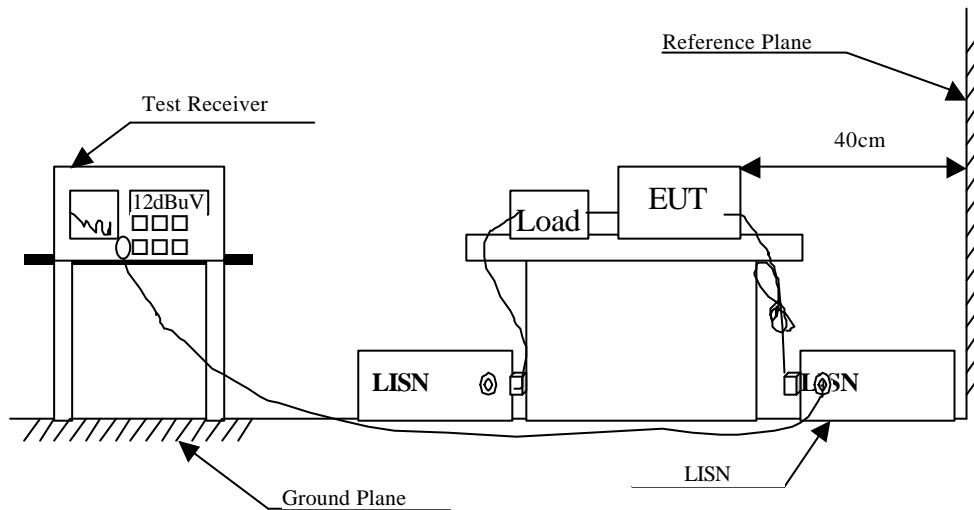

### 2.3 Limits

FCC Part 15 Paragraph 15.207 (dBuV)		
Frequency MHz	Limits	
	uV	dBuV
0.45 - 30	250	48.0



## 2.4 Test Procedure

The EUT and simulators are connected to the main power through a line impedance stabilization network (L.I.S.N.). This provides a 50 ohm /50uH coupling impedance for the measuring equipment. The peripheral devices are also connected to the main power through a LISN that provides a 50ohm/50uH coupling impedance with 50ohm termination. (Please refer to the block diagram of the test setup and photographs.)

Both sides of A.C. line are checked for maximum conducted interference. In order to find the maximum emission, the relative positions of equipment and all of the interface cables must be changed according to ANSI C63.4 /1992 on conducted measurement.

The bandwidth of the field strength meter (R & S Test Receiver ESCS 30) is set at 9kHz.

## 2.5 Test Results

The conducted emission from the EUT is measured and shown in Attachment 1. The acceptance criterion was met and the EUT passed the test.

### 3. Radiated Emission

#### 3.1 Test Equipment

The following test equipment are used during the radiated emission test:

Test Site		Equipment	Manufacturer	Model No./Serial No.	Last Cal.
Site # 1	X	Test Receiver	R & S	ESCS 30 / 825442/14	May, 2000
		Spectrum Analyzer	Advantest	R3261C / 71720140	May, 2000
		Pre-Amplifier	HP	8447D/3307A01812	May, 2000
	X	Bilog Antenna	Chase	CBL6112B / 12452	Sep., 2000
	X	Horn Antenna	EM	EM6917 / 103325	May, 2000
Site # 2	X	Test Receiver	R & S	ESCS 30 / 825442/17	May, 2000
		Spectrum Analyzer	Advantest	R3261C / 71720609	May, 2000
		Pre-Amplifier	HP	8447D/3307A01814	May, 2000
	X	Bilog Antenna	Chase	CBL6112B / 2455	Sep., 2000
	X	Horn Antenna	EM	EM6917 / 103325	May, 2000

- Note:
1. All equipment upon which need to calibrated are with calibration period of 1 year.
  2. Mark “X” test instruments are used to measure the final test results.

#### 3.2 Test Setup

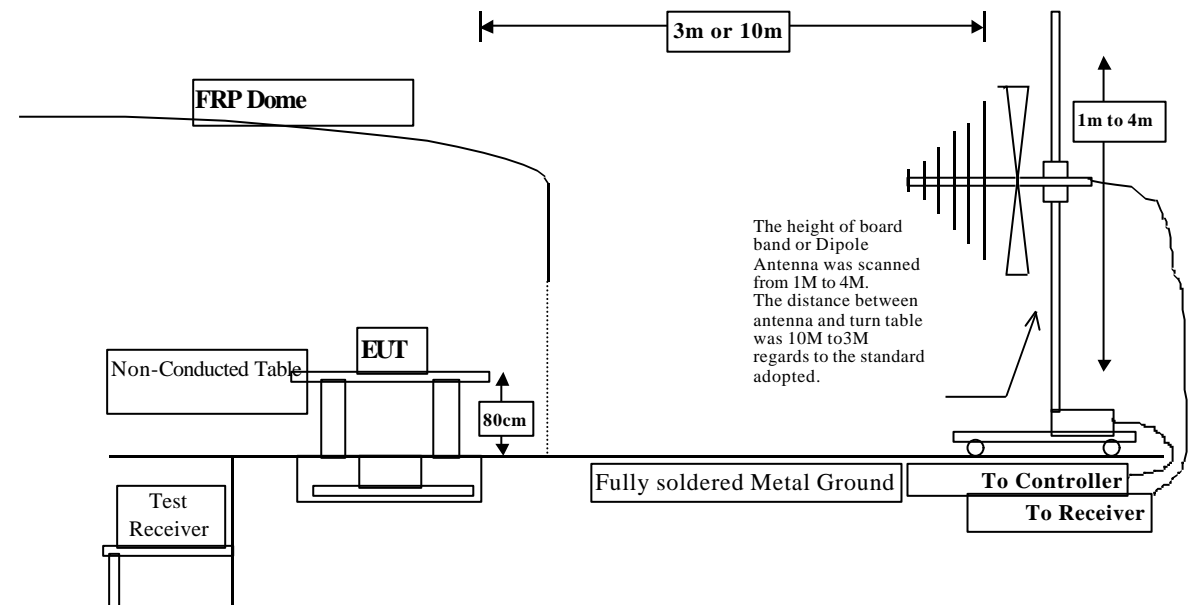

### 3.3 Limits

#### ➤ Fundamental and Harmonics Emission Limits

Frequency MHz	Field Strength of Fundamental		Field Strength of Harmonics	
	(mV/m @3m)	(dBuV/m @3m)	(uV/m @3m)	(dBuV/m @3m)
2400-2483.5	50	94 (Average) 114 (Peak)	500	54 (Average) 74 (Peak)

#### ➤ General Radiated Emission Limits

Emissions radiated outside of the specified frequency bands, except for harmonics, shall be attenuated by at least 50dB below the level of the fundamental or to the general radiated emission limits in paragraph 15.209, whichever is the lesser attenuation.

Frequency MHz	50dB below of the fundamental (dBuV/m @3m)	15.209 Limits (dBuV/m @3m)	General Radiated Limits (dBuV/m @3m)
30-88	40	40	40
88-216	43.5	43.5	43.5
216-960	44	46	46
Above 960	44	54	54

- Remarks :
1. RF Line Voltage (dBuV) = 20 log RF Line Voltage (uV)
  2. In the Above Table, the tighter limit applies at the band edges.
  3. Distance refers to the distance in meters between the measuring instrument antenna and the closed point of any part of the device or system.

### **3.4 Test Procedure**

The EUT and its simulators are placed on a turn table which is 0.8 meter above ground. The turn table can rotate 360 degrees to determine the position of the maximum emission level.

The EUT was positioned such that the distance from antenna to the EUT was 3 meters .

The antenna can move up and down between 1 meter and 4 meters to find out the maximum emission level.

Both horizontal and vertical polarization of the antenna are set on measurement. In order to find the maximum emission, all of the interface cables must be manipulated according to ANSI C63.4 /1992 on radiated measurement.

The bandwidth below 1GHz setting on the field strength meter (R&S Test Receiver ESCS 30 ) is 120 kHz and above 1GHz is 1MHz.

### **3.5 Test Results**

The radiated emission from the EUT is measured and shown in Attachment 1. The acceptance criterion was met and the EUT passed the test.

#### 4. EMI Reduction Method During Compliance Testing

No modification was made during testing.



## 5. Attachment

Attachment 1: Summary of Test Results	Number of Pages: 11
Attachment 2: EUT Test Photographs	Number of Pages: 3
Attachment 3: EUT Detailed Photographs	Number of Pages: 11



## Attachment 1 : Summary of Test Results

The test results in the emission were performed according to the requirements of measurement standard and process. QuieTek Corporation is assumed full responsibility for the accuracy and completeness of these measurements. The test data of the emission are listed as the attached data.

All the tests were carried out with the EUT in normal operation, which was defined as:

- (1) Channel 1
- (2) Channel 3
- (3) Channel 4

**The EUT passed all the tests.**

The uncertainty is calculated in accordance with NAMAS NIS 81, The total uncertainty for this test is as follows:

➤ **Emission Test**

- Uncertainty in the Conducted Emission Test:  $< \pm 2.0$  dB
- Uncertainty in the field strength measured:  $< \pm 4.0$  dB

## CONDUCTED EMISSION DATA

Date of Test : Dec. 1, 2000 EUT : AV TRANSMITTER  
 Test Mode : Channel 1 Detect Mode : Quasi-Peak

Frequency	Cable Loss	LISN Factor	Reading Level	Measurement Level	Limits
MHz	dB	dB	dBuV	dBuV	dBuV

Line 1:

0.455	0.06	0.10	36.25	36.41	48.00
0.497	0.06	0.10	36.01	36.17	48.00
0.544	0.07	0.10	37.45	37.62	48.00
*0.614	0.07	0.10	38.23	38.40	48.00
13.729	0.31	0.32	17.63	18.26	48.00
24.005	0.38	0.52	15.81	16.70	48.00

Line 2:

0.497	0.06	0.10	28.09	28.25	48.00
*0.563	0.07	0.10	30.25	30.42	48.00
0.653	0.08	0.10	28.05	28.23	48.00
0.723	0.08	0.10	24.55	24.73	48.00
0.909	0.09	0.10	16.05	16.24	48.00
1.102	0.11	0.10	16.55	16.76	48.00

Remarks :

1. “\*” means that this data is the worst emission level.
2. The average measurement was not performed when the peak measured data under the limit of average detection.



## Fundamental Radiated Emission Data

Date of Test : Dec. 1, 2000 EUT : AV TRANSMITTER  
 Test Mode : Normal Test Site : Open Site 2

Freq.	Cable Loss	Probe Factor	PreAMP	Reading Level	Measurement	Margin	Limit	Ant	Turn
MHz	dB	dB/m	dB	dBuV	dBuV/m	dB	dBuV/m	cm	deg

=====  
**Peak Detector (Horizontal)**

Channel 1									
2434.000	3.86	29.31	0.00	51.03	84.19	29.81	114.00	0	0
Channel 3									
2471.900	3.91	29.44	0.00	50.41	83.76	30.24	114.00	0	0
Channel 4									
2412.500	3.84	29.26	0.00	50.09	83.19	30.81	114.00	0	0

**Peak Detector (Vertical)**

Channel 1									
2434.000	3.86	29.31	0.00	52.07	85.23	28.77	114.00	0	0
Channel 3									
2472.300	3.91	29.44	0.00	51.40	84.75	29.25	114.00	0	0
Channel 4									
2412.500	3.84	29.26	0.00	49.91	83.01	30.99	114.00	0	0

Remarks:

1. All Readings below 1GHz are Quasi-Peak, above are average value.
2. “ \* ”, means this data is the worst emission level.
3. Emission Level = Reading Level + Antenna Factor + Cable loss
4. The average measurement was not performed when the peak measured data under the limit of average detection.

## Harmonic Radiated Emission Data

Date of Test : Dec. 1, 2000 EUT : AV TRANSMITTER  
 Test Mode : Channel 1 Test Site : Open Site 2

Freq.	Cable Loss	Probe Factor	PreAMP	Reading Level	Measurement	Margin	Limit	Ant	Turn
MHz	dB	dB/m	dB	dBuV	dBuV/m	dB	dBuV/m	cm	deg

**Peak Detector (Horizontal)**

4867.950	6.30	33.54	34.76	44.76	49.85	24.15	74.00	0	0
7301.930	8.38	36.31	34.90	43.31	53.09	20.91	74.00	0	0
9735.960	10.24	37.45	35.10	42.94	55.53	18.47	74.00	0	0
12169.81	11.98	39.17	34.56	41.43	58.01	15.99	74.00	0	0

**Average Detector (Horizontal)**

9735.910	10.24	37.45	35.10	34.56	47.15	6.85	54.00	0	0
12169.96	11.98	39.17	34.56	32.43	49.01	4.99	54.00	0	0

**Peak Detector (Vertical)**

4867.930	6.30	33.54	34.76	44.64	49.73	24.27	74.00	0	0
7301.920	8.38	36.31	34.90	46.06	55.84	18.16	74.00	0	0
9735.920	10.24	37.45	35.10	42.63	55.22	18.78	74.00	0	0
12169.89	11.98	39.17	34.56	42.86	59.44	14.56	74.00	0	0

**Average Detector (Vertical)**

7301.950	8.38	36.31	34.90	40.44	50.22	3.78	54.00	0	0
9735.890	10.24	37.45	35.10	33.79	46.38	7.62	54.00	0	0
12169.93	11.98	39.17	34.56	33.82	50.40	3.60	54.00	0	0

**Remarks:**

1. All Readings below 1GHz are Quasi-Peak, above are average value.
2. “ \* ”, means this data is the worst emission level.
3. Emission Level = Reading Level + Antenna Factor + Cable loss
4. The average measurement was not performed when the peak measured data under the limit of average detection.

## Harmonic Radiated Emission Data

Date of Test : Dec. 1, 2000 EUT : AV TRANSMITTER  
 Test Mode : Channel 3 Test Site : Open Site 2

Freq.	Cable Loss	Probe Factor	PreAMP	Reading Level	Measurement	Margin	Limit	Ant	Turn
MHz	dB	dB/m	dB	dBuV	dBuV/m	dB	dBuV/m	cm	deg

**Peak Detector (Horizontal)**

4943.900	6.38	33.64	34.72	43.29	48.59	25.41	74.00	0	0
7415.890	8.46	36.41	34.90	39.75	49.72	24.28	74.00	0	0
9887.440	10.36	37.48	35.10	41.54	54.27	19.73	74.00	0	0
12358.79	12.11	39.24	34.41	41.23	58.17	15.83	74.00	0	0

**Average Detector (Horizontal)**

9888.280	10.36	37.48	35.10	32.25	44.98	9.02	54.00	0	0
12360.03	12.11	39.24	34.41	32.61	49.55	4.45	54.00	0	0

**Peak Detector (Vertical)**

4944.340	6.38	33.64	34.72	43.71	49.01	24.99	74.00	0	0
7415.610	8.46	36.41	34.90	41.76	51.73	22.27	74.00	0	0
9888.320	10.36	37.48	35.10	41.32	54.05	19.95	74.00	0	0
12362.95	12.11	39.24	34.41	42.35	59.29	14.71	74.00	0	0

**Average Detector (Vertical)**

9888.320	10.36	37.48	35.10	32.21	44.94	9.06	54.00	0	0
12359.59	12.11	39.24	34.41	35.63	52.57	1.43	54.00	0	0

Remarks:

1. All Readings below 1GHz are Quasi-Peak, above are average value.
2. “ \* ”, means this data is the worst emission level.
3. Emission Level = Reading Level + Antenna Factor + Cable loss
4. The average measurement was not performed when the peak measured data under the limit of average detection.



## Harmonic Radiated Emission Data

Date of Test : Dec. 1, 2000 EUT : AV TRANSMITTER  
 Test Mode : Channel 4 Test Site : Open Site 2

Freq.	Cable Loss	Probe Factor	PreAMP dB	Reading Level	Measurement	Margin	Limit	Ant	Turn
MHz	dB	dB/m	dB	dBuV	dBuV/m	dB	dBuV/m	cm	deg

**Peak Detector (Horizontal)**

4824.940	6.27	33.50	34.77	43.71	48.71	25.29	74.00	0	0
7237.410	8.32	36.24	34.90	43.85	53.51	20.49	74.00	0	0
9649.890	10.18	37.43	35.10	42.87	55.38	18.62	74.00	0	0
12062.22	11.91	39.13	34.65	41.57	57.96	16.04	74.00	0	0

**Average Detector (Horizontal)**

9649.910	10.18	37.43	35.10	34.64	47.15	6.85	54.00	0	0
12062.30	11.91	39.13	34.65	32.49	48.88	5.12	54.00	0	0

**Peak Detector (Vertical)**

4824.940	6.27	33.50	34.77	43.31	48.31	25.69	74.00	0	0
7237.380	8.32	36.24	34.90	46.33	55.99	18.01	74.00	0	0
9649.830	10.18	37.43	35.10	43.15	55.66	18.34	74.00	0	0
12062.49	11.91	39.13	34.65	42.10	58.49	15.51	74.00	0	0

**Average Detector (Vertical)**

7237.370	8.32	36.24	34.90	42.24	51.90	2.10	54.00	0	0
9649.940	10.18	37.43	35.10	35.30	47.81	6.19	54.00	0	0
12062.40	11.91	39.13	34.65	33.69	50.08	3.92	54.00	0	0

**Remarks:**

1. All Readings below 1GHz are Quasi-Peak, above are average value.
2. “ \* ”, means this data is the worst emission level.
3. Emission Level = Reading Level + Antenna Factor + Cable loss
4. The average measurement was not performed when the peak measured data under the limit of average detection.



## General Radiated Emission Data

Date of Test : Dec. 1, 2000 EUT : AV TRANSMITTER  
 Test Mode : Channel 1 Test Site : Open Site 2

Freq.	Cable Loss	Probe Factor	PreAMP	Reading Level	Measurement	Margin	Limit	Ant	Turn
MHz	dB	dB/m	dB	dBuV	dBuV/m	dB	dBuV/m	cm	deg
=====									
Horizontal :									
33.880	1.03	15.97	26.00	35.00	26.00	14.00	40.00	0	0
56.190	1.12	5.94	26.00	47.00	28.06	11.94	40.00	0	0
80.440	1.22	9.83	26.00	39.80	24.86	15.14	40.00	0	0
*313.240	2.18	13.96	26.00	52.00	42.14	3.86	46.00	0	0
416.060	2.60	17.30	26.00	40.60	34.50	11.50	46.00	0	0
934.040	4.73	21.14	26.00	35.20	35.06	10.94	46.00	0	0

Vertical :									
*30.000	1.02	18.54	26.00	43.80	37.36	2.14	39.50	0	0
58.130	1.13	8.11	26.00	49.20	32.45	7.55	40.00	0	0
81.410	1.23	9.51	26.00	38.40	23.14	16.86	40.00	0	0
311.300	2.17	14.16	26.00	46.60	36.93	9.07	46.00	0	0
423.820	2.63	16.91	26.00	38.20	31.74	14.26	46.00	0	0
932.100	4.72	21.83	26.00	35.40	35.95	10.05	46.00	0	0

Remarks:

1. All Readings below 1GHz are Quasi-Peak, above are average value.
2. “ \* ”, means this data is the worst emission level.
3. Emission Level = Reading Level + Antenna Factor + Cable loss

## General Radiated Emission Data

Date of Test : Dec. 1, 2000 EUT : AV TRANSMITTER  
 Test Mode : Channel 3 Test Site : Open Site 2

Freq.	Cable Loss	Probe Factor	PreAMP dB	Reading Level	Measurement	Margin	Limit	Ant	Turn
MHz	dB	dB/m	dB	dBuV	dBuV/m	dB	dBuV/m	cm	deg

Horizontal :

56.190	1.12	5.94	26.00	46.40	27.46	12.54	40.00	0	0
*74.620	1.20	8.63	26.00	53.00	36.83	3.17	40.00	0	0
313.240	2.18	13.96	26.00	47.80	37.94	8.06	46.00	0	0
416.060	2.60	17.30	26.00	39.80	33.70	12.30	46.00	0	0
765.260	4.04	20.17	26.00	37.80	36.01	9.99	46.00	0	0
934.040	4.73	21.14	26.00	32.40	32.26	13.74	46.00	0	0

Vertical :

*37.760	1.05	11.97	26.00	51.40	37.42	2.58	40.00	0	0
58.130	1.13	8.11	26.00	50.00	33.25	6.75	40.00	0	0
310.330	2.17	14.13	26.00	44.20	34.49	11.51	46.00	0	0
416.060	2.60	17.17	26.00	38.00	31.77	14.23	46.00	0	0
812.790	4.23	20.51	26.00	34.80	33.54	12.46	46.00	0	0
934.040	4.73	22.04	26.00	33.00	33.76	12.24	46.00	0	0

Remarks:

1. All Readings below 1GHz are Quasi-Peak, above are average value.
2. “ \* ”, means this data is the worst emission level.
3. Emission Level = Reading Level + Antenna Factor + Cable loss

## General Radiated Emission Data

Date of Test : Dec. 1, 2000 EUT : AV TRANSMITTER  
 Test Mode : Channel 4 Test Site : Open Site 2

Freq.	Cable Loss	Probe Factor	PreAMP dB	Reading Level	Measurement	Margin	Limit	Ant	Turn
MHz	dB	dB/m	dB	dBuV	dBuV/m	dB	dBuV/m	cm	deg

Horizontal :

*56.190	1.12	5.94	26.00	52.40	33.46	6.54	40.00	0	0
96.930	1.29	11.94	26.00	34.20	21.43	22.07	43.50	0	0
262.800	1.97	13.59	26.00	33.00	22.56	23.44	46.00	0	0
309.360	2.16	13.73	26.00	46.00	35.89	10.11	46.00	0	0
423.820	2.63	17.21	26.00	41.80	35.64	10.36	46.00	0	0
783.690	4.11	20.26	26.00	37.60	35.97	10.03	46.00	0	0

Vertical :

*30.000	1.02	18.54	26.00	38.20	31.76	7.74	39.50	0	0
57.160	1.13	7.90	26.00	47.20	30.22	9.78	40.00	0	0
309.360	2.16	14.13	26.00	43.60	33.89	12.11	46.00	0	0
414.120	2.59	17.26	26.00	39.60	33.45	12.55	46.00	0	0
812.790	4.23	20.51	26.00	34.60	33.34	12.66	46.00	0	0
926.280	4.70	21.91	26.00	32.40	33.00	13.00	46.00	0	0

Remarks:

1. All Readings below 1GHz are Quasi-Peak, above are average value.
2. “ \* ”, means this data is the worst emission level.
3. Emission Level = Reading Level + Antenna Factor + Cable loss

# Band Edge Data

Date of Test : Dec. 1, 2000 EUT : AV TRANSMITTER  
 Test Mode : Channel 4 Test Site : Open Site 2

Figure:

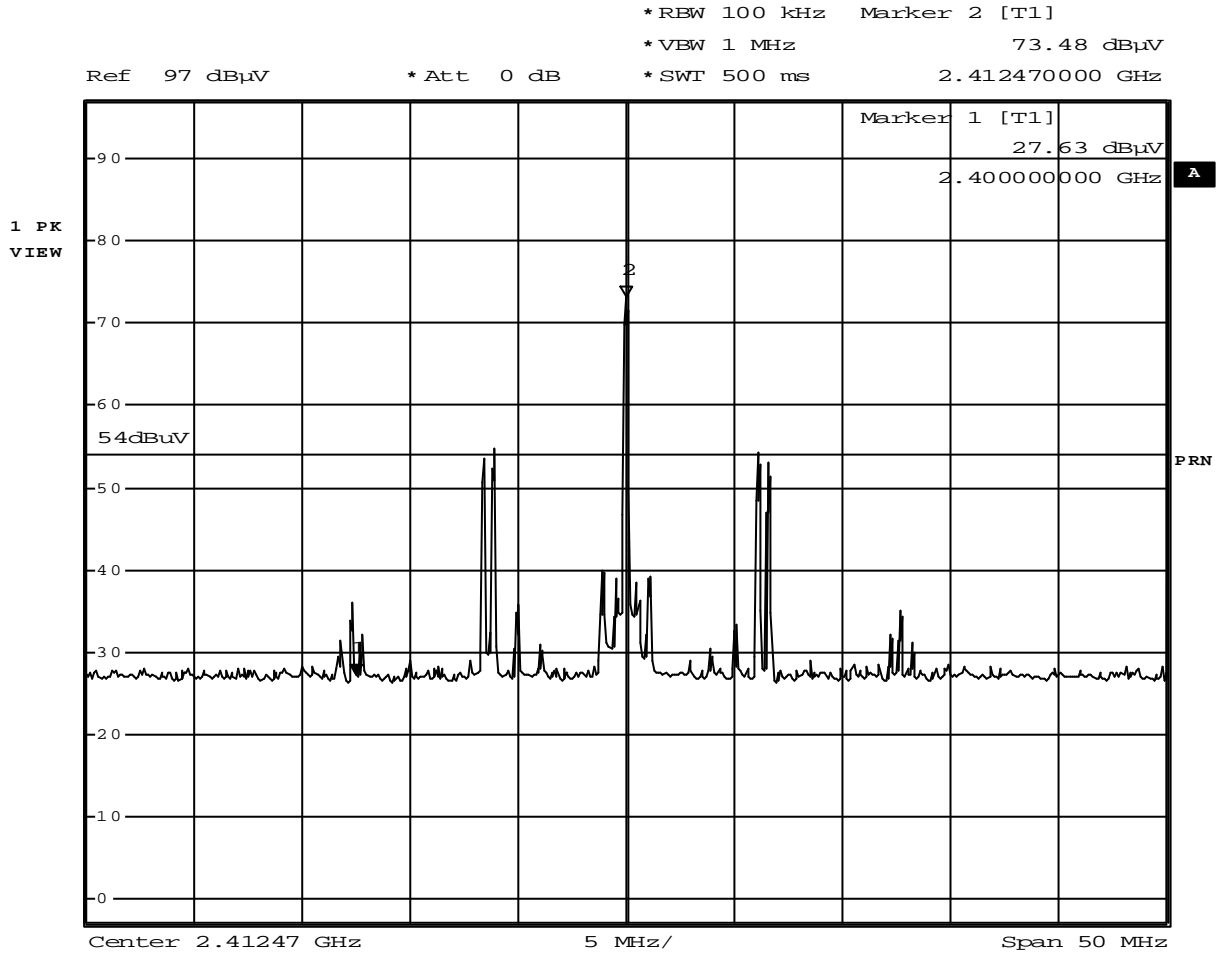

Date: 3.JAN.2001 14:33:50



# Band Edge Data

Date of Test : Dec. 1, 2000 EUT : AV TRANSMITTER  
 Test Mode : Channel 3 Test Site : Open Site 2

Figure:

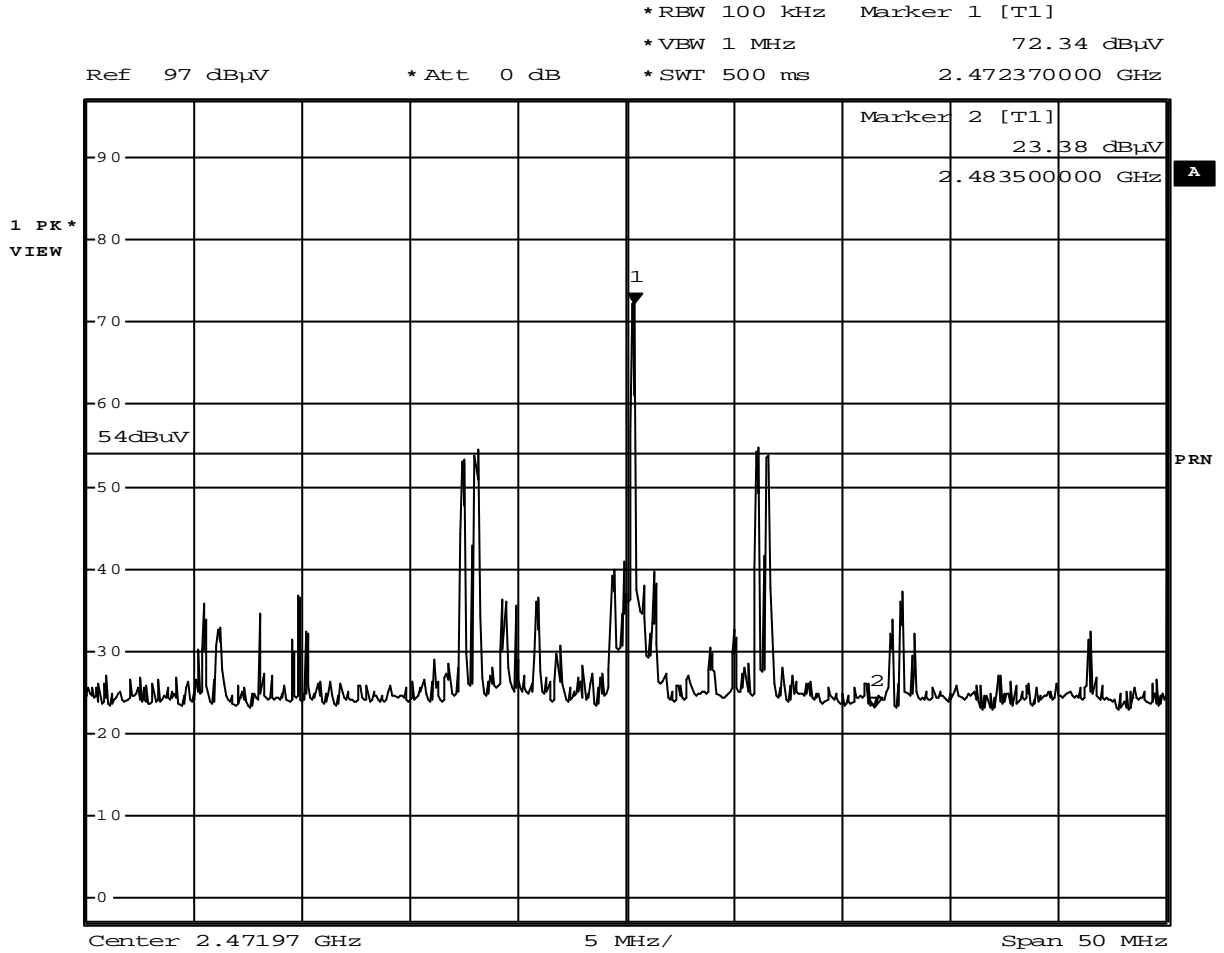

Date: 3.JAN.2001 14:39:59