

Tranwo Technology Corp.

TEST REPORT

REPORT NUMBER
200200110TWN-001

ISSUE DATE

Mar. 13, 2020

PAGES
62

© 2020 INTERTEK



Radio Spectrum TEST REPORT

Applicant:	Tranwo Technology Corp. No.236, Sec. 3, Huanbei Rd., Jubei City, Hsinchu County 30265, Taiwan
Product:	2.4GHz Digital RF Module
Model No.:	WF7916
Brand Name:	TRANWO
FCC ID:	O6L-WF7916
Test Method/ Standard:	47 CFR FCC Part 15.247 & ANSI C63.10 2013 KDB 558074 D01 v05r02
Test By:	Intertek Testing Services Taiwan Ltd., Hsinchu Laboratory No. 11, Lane 275, Ko-Nan 1 Street, Chia-Tung Li, Shiang-Shan District, Hsinchu City, Taiwan



Prepared and Checked by:

Mark Chang

Mark Chang
Engineer

Approved by:

Durant Wei

Durant Wei
Engineer

This report is for the exclusive use of Intertek's Client and is provided pursuant to the agreement between Intertek and its Client. Intertek's responsibility and liability are limited to the terms and conditions of the agreement. Intertek assumes no liability to any party, other than to the Client in accordance with the agreement, for any loss, expense or damage occasioned by the use of this report. Only the Client is authorized to permit copying or distribution of this report and then only in its entirety. Any use of the Intertek name or one of its marks for the sale or advertisement of the tested material, product or service must first be approved in writing by Intertek. The observations and test results in this report are relevant only to the sample tested. This report by itself does not imply that the material, product, or service is or has ever been under an Intertek certification program.

Revision History

Report No.	Issue Date	Revision Summary
200200110TWN-001	Mar. 13, 2020	Original report

Table of Contents

1. General Information	6
1.1 Identification of the EUT	6
1.2 Antenna description	6
1.3 Operation mode	7
1.4 Peripherals equipment	8
2. Minimum 6 dB Bandwidth	9
2.1 Instrument Setting.....	9
2.2 Test Procedure	9
2.3 Test Diagram	9
2.4 Limit.....	9
2.5 Operating Environment Condition	9
2.6 Test Results	10
3. Maximum Peak Conducted Output Power	15
3.1 Instrument Setting.....	15
3.2 Test Procedure	15
3.3 Test Diagram	15
3.4 Limit.....	15
3.5 Operating Environment Condition	15
3.6 Test Results	16
4. Power Spectral Density.....	17
4.1 Instrument Setting.....	17
4.2 Test Procedure	17
4.3 Test Diagram	17
4.4 Limit.....	17
4.5 Operating Environment Condition	17
4.6 Test Results	18
5. Emissions in Non-Restricted Frequency Bands	23
5.1 Instruments Setting	23
5.2 Test Procedure	23
5.3 Test Diagram	23
5.4 Limit.....	23
5.5 Operating Environment Condition	23
5.6 Test Results	24
6. Emissions in Restricted Frequency Bands (Radiated emission measurements)	32
6.1 Instrument Setting.....	32
6.2 Test Procedure	32
6.3 Test Diagram	33
6.3.1 Radiated emission from 9kHz to 30MHz uses Loop Antenna:	33
6.3.2 Radiated emission below 1GHz using Bilog Antenna	33

TEST REPORT

- 6.3.3 Radiated emission above 1GHz using Horn Antenna 34
- 6.4 Limit..... 34
- 6.5 Operating Environment Condition 34
- 6.6 Test Result..... 35

- 7. Emission on Band Edge..... 45
 - 7.1 Instrument Setting..... 45
 - 7.2 Test Procedure 45
 - 7.3 Operating Environment Condition 45
 - 7.4 Test Results 46

- 8. AC Power Line Conducted Emission 56
 - 8.1 Measuring instrument setting..... 56
 - 8.2 Test Procedure 56
 - 8.3 Test Diagram 56
 - 8.4 Limit..... 57
 - 8.5 Operating Environment Condition 57
 - 8.6 Test Results 58

- Appendix A: Test equipment list..... 60

- Appendix B: Measurement Uncertainty 62

Summary of Test Data

Test Requirement	Applicable Rule (Section 15.247)	Result
Minimum 6 dB Bandwidth	15.247(a)(2)	Pass
Maximum Peak Conducted Output Power	15.247(b)(3)	Pass
Power Spectral Density	15.247(e)	Pass
Emissions In Non-Restricted Frequency Bands	15.247(d)	Pass
Emissions In Restricted Frequency Bands (Radiated emission measurements)	15.247(d), 15.205, 15.209	Pass
Emission On The Band Edge	15.247(d), 15.205	Pass
AC Power Line Conducted Emission	15.207	Pass
Antenna Requirement	15.203	Pass

Note: Please note that the test results with statement of conformity, the decision rules which are based on: Safety Testing: the specification, standard or IEC Guide 115.

Other Testing: the specification, standard and not taking into account the measurement uncertainty.

1. General Information

1.1 Identification of the EUT

Product:	2.4GHz Digital RF Module
Model No.:	WF7916
Operating Frequency:	2412 MHz ~ 2462 MHz for 802.11b, 802.11g, 802.11n HT20 2422 MHz ~ 2452 MHz for 802.11n HT40
Channel Number:	11 channels for 2412 MHz ~ 2462 MHz 7 channels for 2422 MHz ~ 2452 MHz
Frequency of Each Channel:	2412+5 k, k=0 ~ 10 for 802.11b, 802.11g, 802.11n HT20 2422+5 k, k=0 ~ 6 for 802.11n HT40
Access scheme:	DSSS, OFDM
Rated Power:	DC 3.3V
Power Cord:	N/A
Sample receiving date:	Feb. 07, 2020
Sample condition:	Workable
Test Date(s):	Feb. 18, 2020 ~ Feb. 27, 2020

1.2 Antenna description

Antenna 1

Antenna Gain : 2 dBi
 Antenna Type : Dipole antenna
 Connector Type : I-Pex

Antenna 2

Antenna Gain : 2 dBi
 Antenna Type : Dipole antenna
 Connector Type : I-Pex

1.3 Operation mode

The EUT was supplied with DC 3.3 V from Host (Test voltage: 120Vac, 60Hz).

EUT connected to Notebook USB port, executing “MT7601 USB QA Test Program” and select different frequency and modulation.

With individual verifying, the maximum output power was found out 1 Mbps data rate for 802.11b mode, 6 Mbps data rate for 802.11g mode, 6.5 Mbps data rate for 802.11n(HT20) mode, 13.5 Mbps data rate for 802.11n(HT40) mode the final tests were executed under these conditions recorded in this report individually.

The signal is maximized through rotation and placement in the three orthogonal axes.

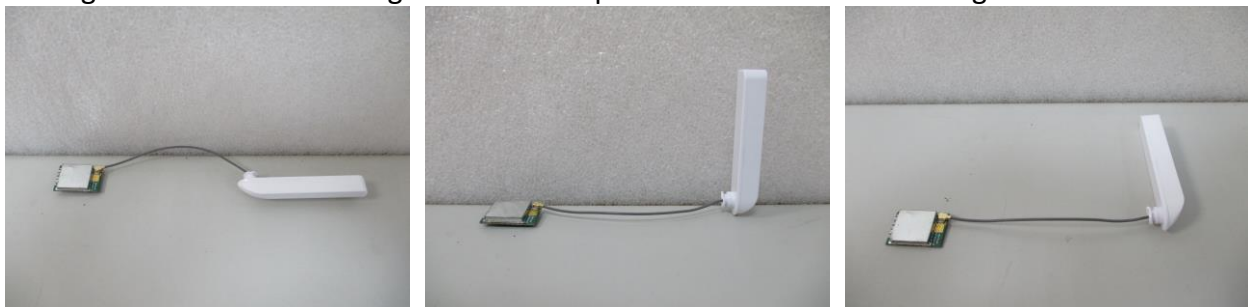

X axis

Y axis

Z axis

After verifying three axes, we found the maximum electromagnetic field was occurred at Z axis. The final test data was executed under this configuration.

Modulation mode	Transmit path
	Chain 0 / Main
802.11b	V
802.11g	V
802.11 n (HT20)	V
802.11 n (HT40)	V

1.4 Peripherals equipment

Peripherals	Brand	Model No.	Serial No.	Data cable
Notebook PC	ASUS	N81V	N/A	Micro USB shielded cable 1 meter x 1
Adapter	CSEC	CS6F050100FUF	N/A	N/A
Host	TRANWO	D-VM2506R	N/A	N/A

2. Minimum 6 dB Bandwidth

2.1 Instrument Setting

Spectrum Parameter	Setting
Detector	Peak
RBW	100kHz
VBW	$\geq 3 \times \text{RBW}$
Sweep	Auto couple
Trace	Allow the trace to stabilize.
Span	Between two times and five times the occupied bandwidth
Attenuation	Auto

2.2 Test Procedure

Step 1	The transmitter output was connected to the spectrum analyzer.
Step 2	Test was performed accordance with ANSI C63.10.
Step 3	Measure the maximum width of the emission that is constrained by the frequencies associated with the two outermost amplitude points (upper and lower frequencies) that are attenuated by 6 dB relative to the maximum level measured in the fundamental emission

2.3 Test Diagram

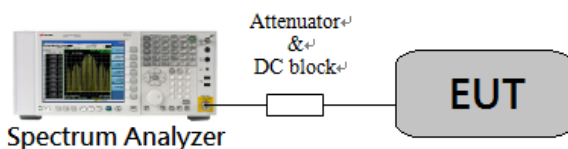

2.4 Limit

The minimum 6 dB bandwidth shall be at least 500 kHz.

2.5 Operating Environment Condition

Temperature (°C) :	20
Relative Humidity (%) :	58

2.6 Test Results

Mode	Channel	Frequency (MHz)	6dB Bandwidth (MHz)	Limit (MHz)	Result
802.11b	1	2412	10.06	>0.5	Pass
	6	2437	10.06	>0.5	Pass
	11	2462	10.05	>0.5	Pass
802.11g	1	2412	16.36	>0.5	Pass
	6	2437	16.33	>0.5	Pass
	11	2462	16.33	>0.5	Pass
802.11n(HT20)	1	2412	17.10	>0.5	Pass
	6	2437	16.99	>0.5	Pass
	11	2462	17.08	>0.5	Pass
802.11n(HT40)	3	2422	35.30	>0.5	Pass
	6	2437	35.36	>0.5	Pass
	9	2452	35.28	>0.5	Pass

Chain0 : 6dB Bandwidth @ 802.11b Mode Ch 1

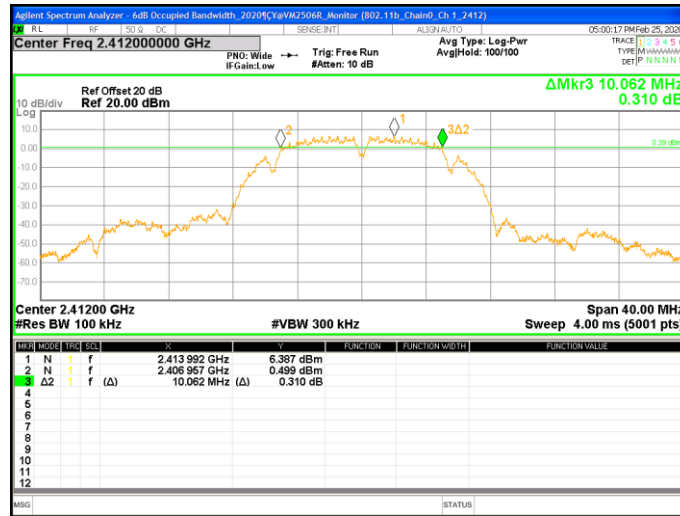

Chain0 : 6dB Bandwidth @ 802.11b Mode Ch 6

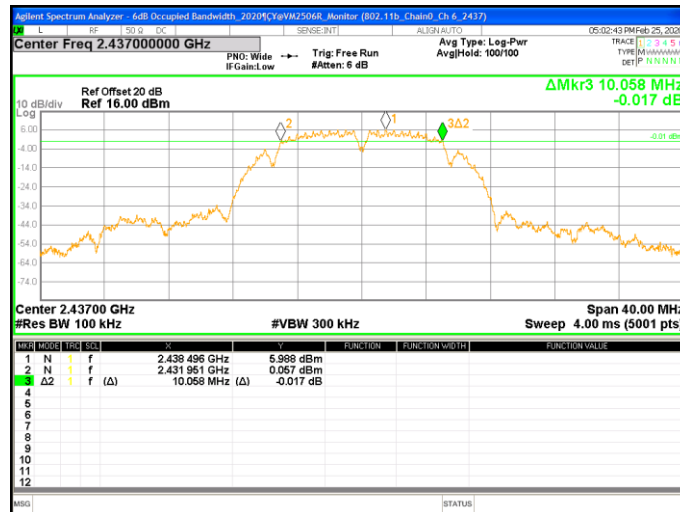

Chain0 : 6dB Bandwidth @ 802.11b Mode Ch11

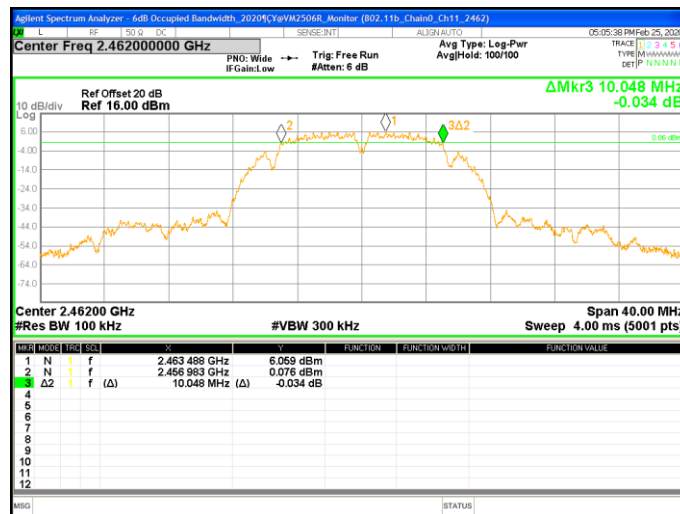

Chain0 : 6dB Bandwidth @ 802.11g Mode Ch 1



Chain0 : 6dB Bandwidth @ 802.11g Mode Ch 6

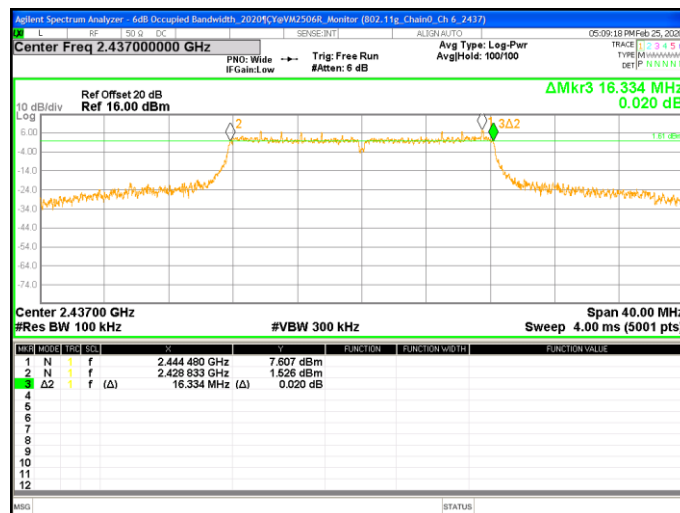

Chain0 : 6dB Bandwidth @ 802.11g Mode Ch11

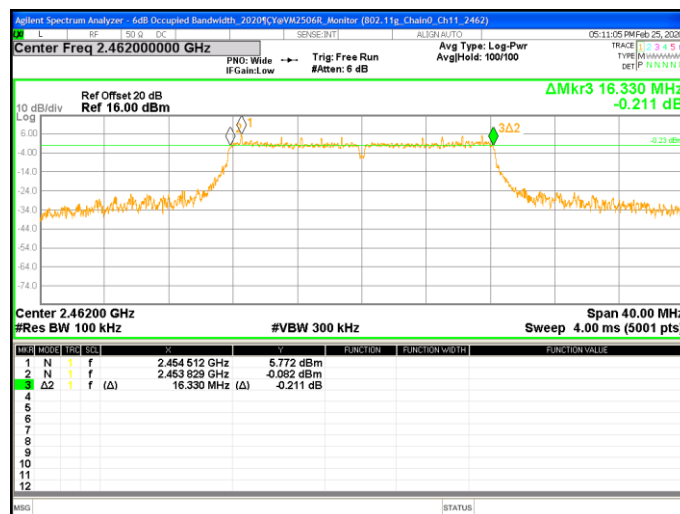

Chain0 : 6dB Bandwidth @ 802.11n(HT20) Mode Ch 1



Chain0 : 6dB Bandwidth @ 802.11n(HT20) Mode Ch 6

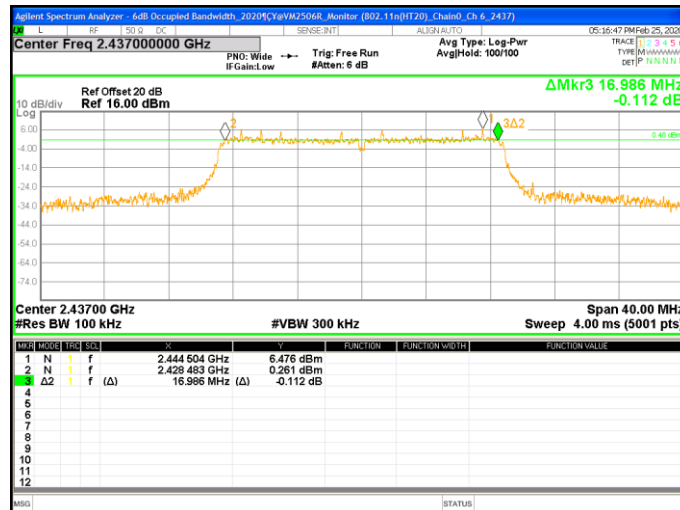

Chain0 : 6dB Bandwidth @ 802.11n(HT20) Mode Ch11

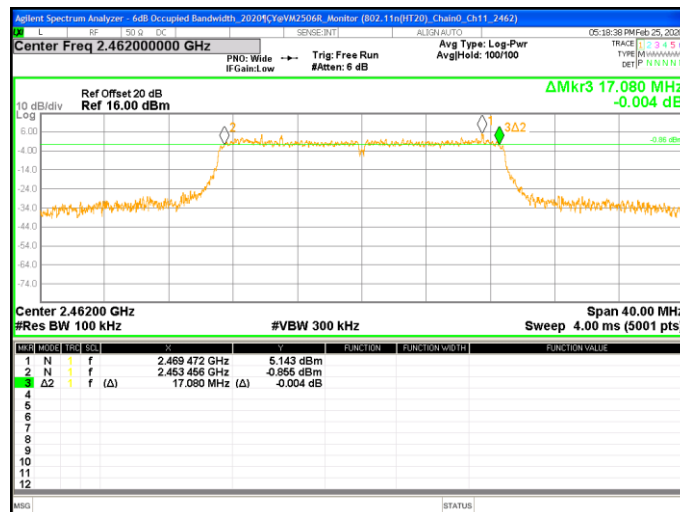

Chain0 : 6dB Bandwidth @ 802.11n(HT40) Mode Ch 3

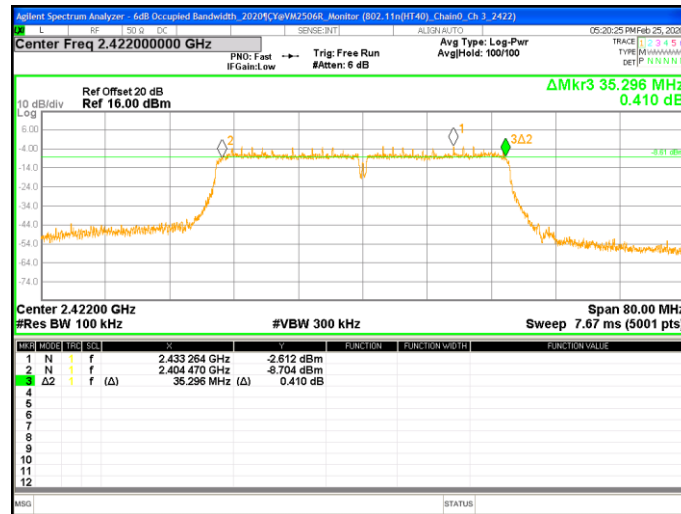

Chain0 : 6dB Bandwidth @ 802.11n(HT40) Mode Ch 6

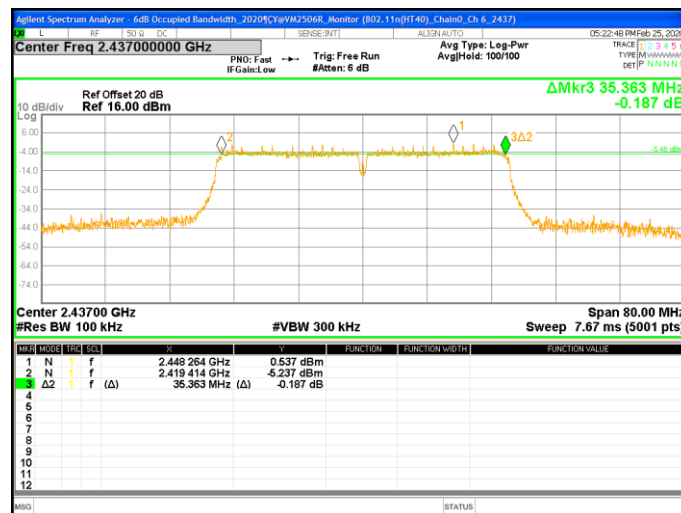

Chain0 : 6dB Bandwidth @ 802.11n(HT40) Mode Ch 9

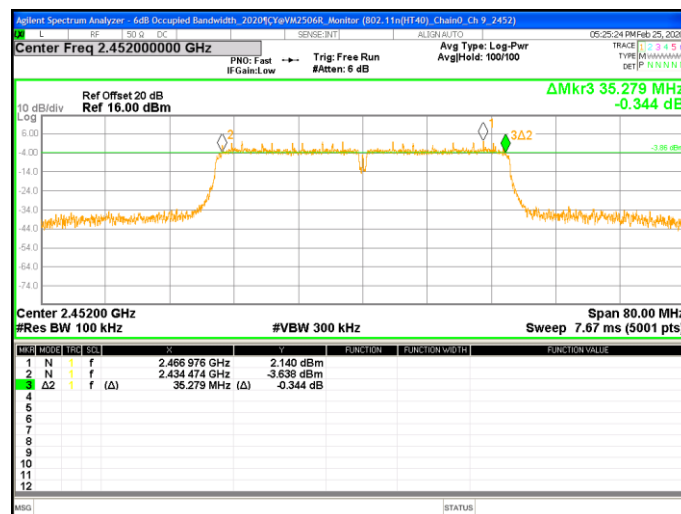

3. Maximum Peak Conducted Output Power

3.1 Instrument Setting

Power Meter Parameter	Setting
Bandwidth	65MHz bandwidth is greater than the EUT emission bandwidth
Detector	Peak & Average

3.2 Test Procedure

The preferred methodology is to use integrated average power measurements, as described in 11.9.2 and 11.13.3 of ANSI C63.10. The peak integrated band power methods of 11.9.1.2 and 11.13.3.2 of ANSI C63.10 are not applicable for FCC compliance testing purposes.

3.3 Test Diagram

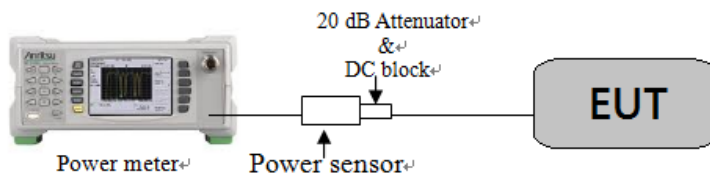

3.4 Limit

For systems using digital modulation in the 2400-2483.5 MHz: 1 Watt (30dBm)

3.5 Operating Environment Condition

Temperature (°C) :	20
Relative Humidity (%) :	58

3.6 Test Results

Mode	Channel	Frequency (MHz)	Data Rate (Mbps)	Output Power (AV) (dBm)	Total Power (AV) (mW)	Maximum power (PK) (dBm)	Maximum power (PK) (mW)	Limit (dBm)	Margin (dB)
802.11b	1	2412	1	16.74	47.21	20.27	106.41	30	-9.73
	6	2437		16.63	46.03	20.20	104.71	30	-9.80
	11	2462		16.67	46.45	20.11	102.57	30	-9.89
802.11g	1	2412	6	14.50	28.18	22.65	184.08	30	-7.35
	6	2437		18.78	75.51	24.67	293.09	30	-5.33
	11	2462		16.55	45.19	23.23	210.38	30	-6.77
802.11n (HT20)	1	2412	6.5	13.39	21.83	21.56	143.22	30	-8.44
	6	2437		17.30	53.70	24.16	260.62	30	-5.84
	11	2462		16.75	47.32	23.84	242.10	30	-6.16
802.11n (HT40)	3	2422	13.5	12.14	16.37	19.37	86.50	30	-10.63
	6	2437		14.99	31.55	22.02	159.22	30	-7.98
	9	2452		15.25	33.50	22.30	169.82	30	-7.70

4. Power Spectral Density

4.1 Instrument Setting

Spectrum Function	Setting
Detector	Peak
RBW	≥ 3 kHz
VBW	$\geq 3 \times$ RBW
Sweep	Auto couple
Trace	Max hold
Span	1.5 times x 6dB bandwidth
Attenuation	Auto

4.2 Test Procedure

Step 1	Test procedure refer to subclause 11.10 of ANSI C63.10.
Step 2	Using the maximum conducted output power in the fundamental emission demonstrates compliance. The EUT must be configured to transmit continuously at full power over the measurement duration.
Step 3	Use the peak marker function to determine the maximum amplitude level within the RBW.

4.3 Test Diagram

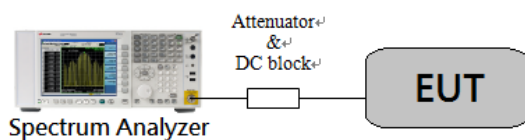

4.4 Limit

For digitally modulated systems, the power spectral density conducted from the intentional radiator to the antenna shall not be greater than 8 dBm in any 3 kHz band during any time interval of continuous transmission

4.5 Operating Environment Condition

Temperature (°C) :	20
Relative Humidity (%) :	58

4.6 Test Results

Mode	Channel	Frequency (MHz)	RBW factor	PSD in 10kHz	PSD in 3kHz		Limit (dBm)	Margin (dB)
					(dBm)	(mw)		
802.11b	1	2412	5.23	4.83	-0.40	0.91	8	-8.40
	6	2437	5.23	4.67	-0.56	0.88	8	-8.56
	11	2462	5.23	-3.26	-8.49	0.14	8	-16.49
802.11g	1	2412	5.23	-6.35	-11.58	0.07	8	-19.58
	6	2437	5.23	-2.62	-7.84	0.16	8	-15.84
	11	2462	5.23	-5.25	-10.47	0.09	8	-18.47
802.11n(HT20)	1	2412	5.23	-7.83	-13.05	0.05	8	-21.05
	6	2437	5.23	-3.79	-9.02	0.13	8	-17.02
	11	2462	5.23	-3.88	-9.11	0.12	8	-17.11
802.11n(HT40)	3	2422	5.23	-11.68	-16.91	0.02	8	-24.91
	6	2437	5.23	-8.69	-13.92	0.04	8	-21.92
	9	2452	5.23	-6.69	-11.92	0.06	8	-19.92

Chain0 : Power Spectral Density @ 802.11b Mode Ch 1



Chain0 : Power Spectral Density @ 802.11b Mode Ch 6



Chain0 : Power Spectral Density @ 802.11b Mode Ch11



Chain0 : Power Spectral Density @ 802.11g Mode Ch 1

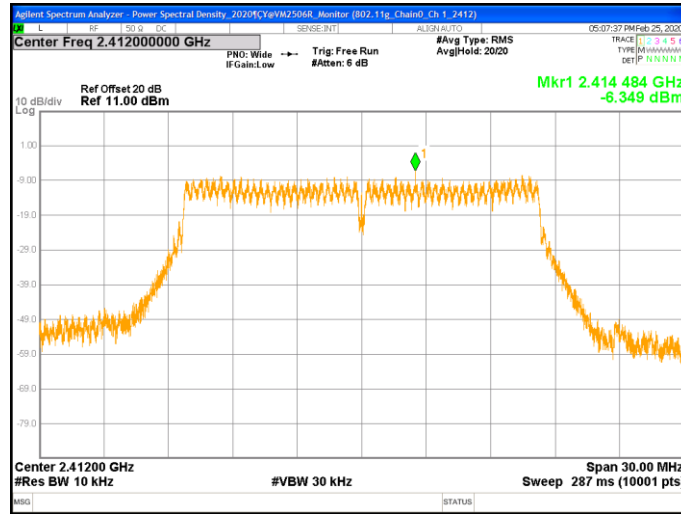

Chain0 : Power Spectral Density @ 802.11g Mode Ch 6

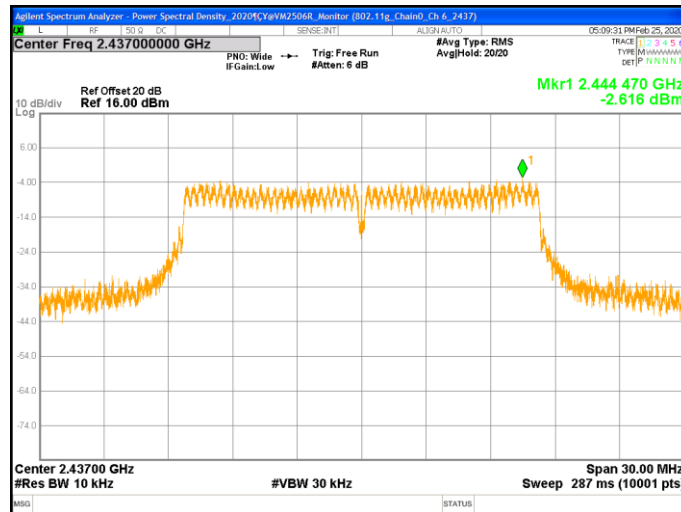

Chain0 : Power Spectral Density @ 802.11g Mode Ch11

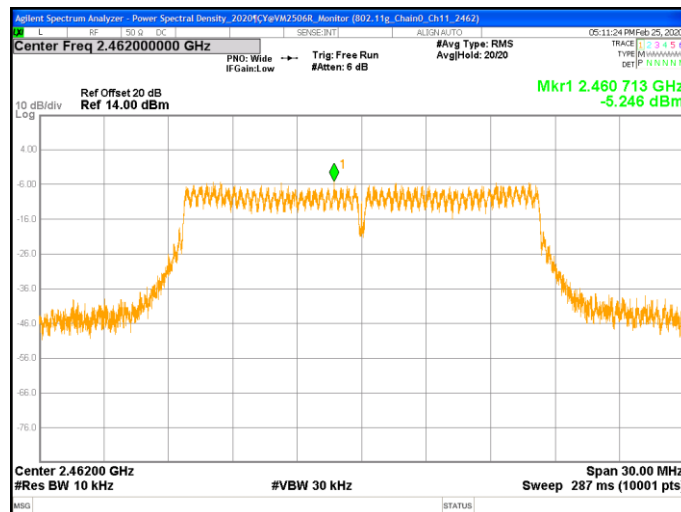

Chain0 : Power Spectral Density @ 802.11n(HT20) Mode Ch 1

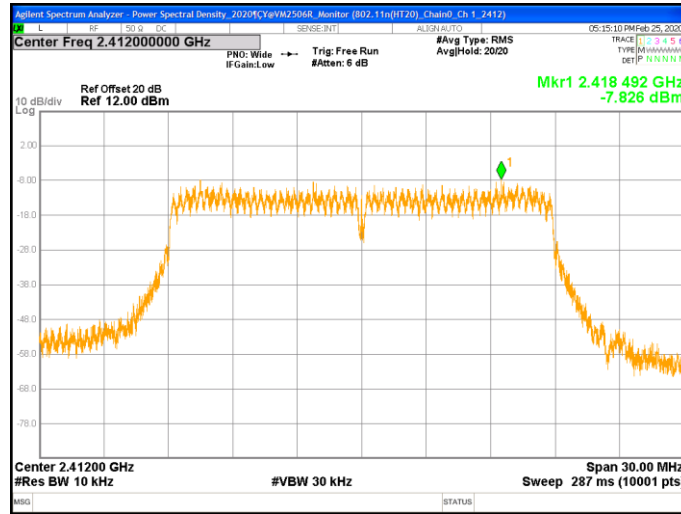

Chain0 : Power Spectral Density @ 802.11n(HT20) Mode Ch 6

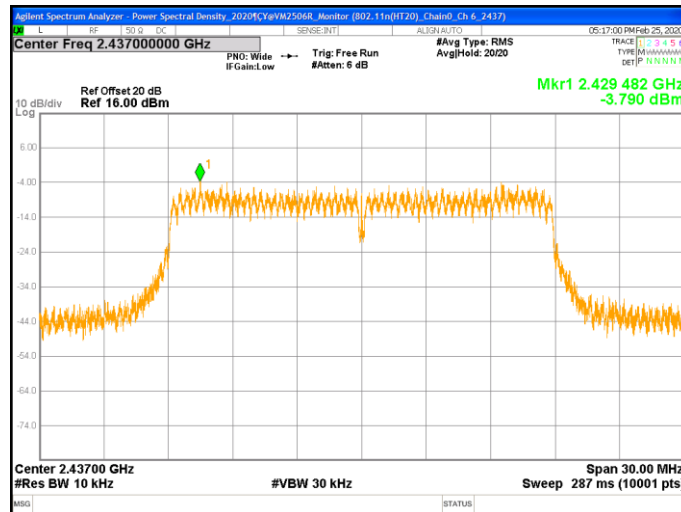

Chain0 : Power Spectral Density @ 802.11n(HT20) Mode Ch11

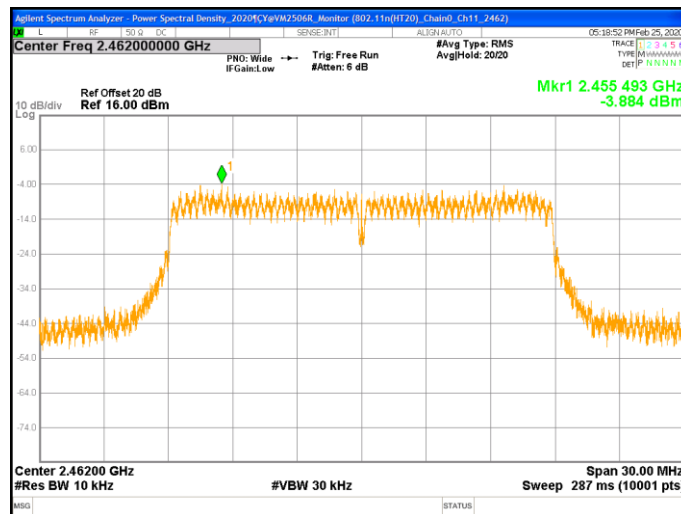

Chain0 : Power Spectral Density @ 802.11n(HT40) Mode Ch 3

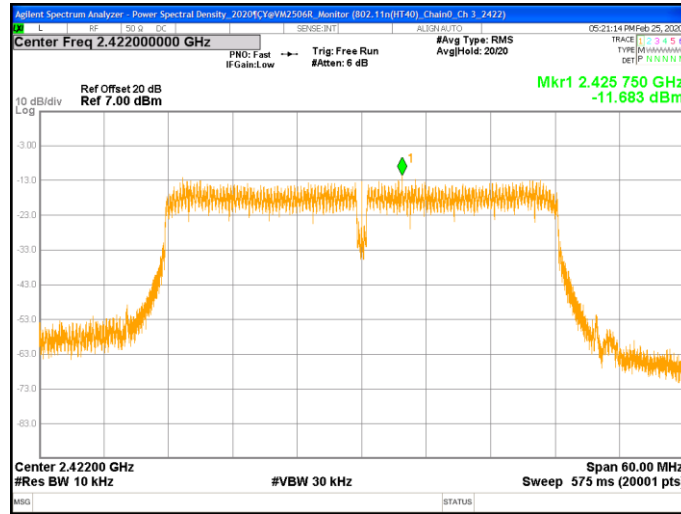

Chain0 : Power Spectral Density @ 802.11n(HT40) Mode Ch 6

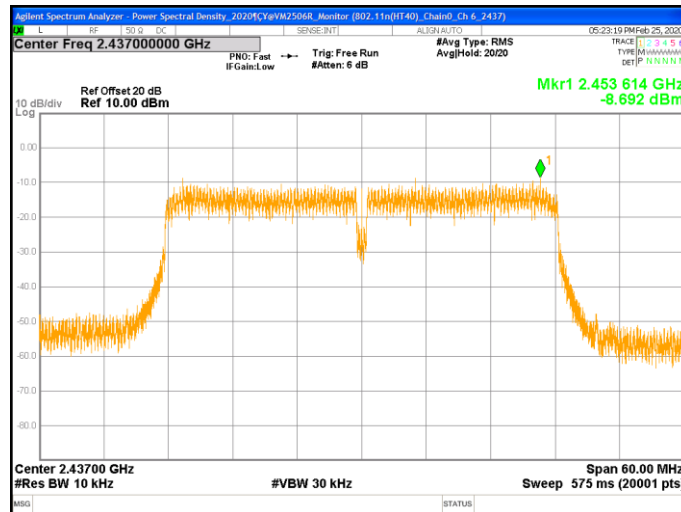

Chain0 : Power Spectral Density @ 802.11n(HT40) Mode Ch 9

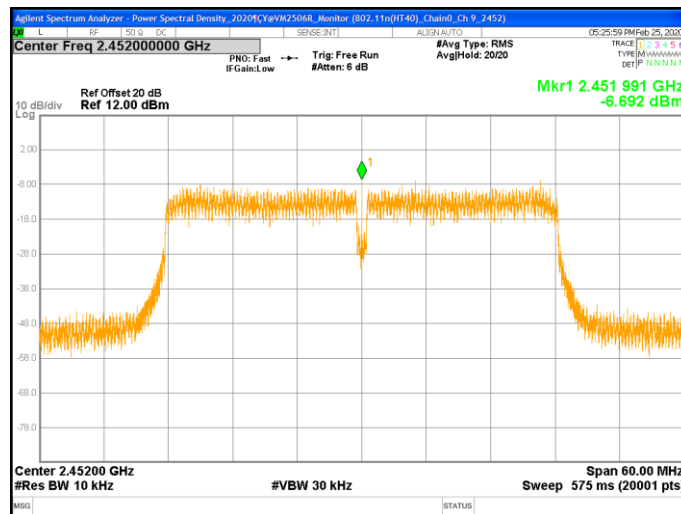

5. Emissions in Non-Restricted Frequency Bands

5.1 Instruments Setting

Spectrum Function	Setting (Reference Level)	Setting (Emission Level)
Detector	Peak	Peak
RBW	≥ 100 kHz	≥ 100 kHz
VBW	$\geq 3 \times$ RBW	$\geq 3 \times$ RBW
Sweep	Auto couple	Auto couple
Trace	Max hold	Max hold
Span	≥ 1.5 time 6dB bandwidth	
Attenuation	Auto	Auto

5.2 Test Procedure

- Step 1 The procedure was used in antenna-port conducted and connected to the spectrum analyzer.
- Step 2 Set instrument center frequency to center frequency.
- Step 3 Use the parameter configured in subclause 11.11 of ANSI C63.10 to measure.
- Step 4 Use the peak marker function to determine the maximum amplitude level.

5.3 Test Diagram

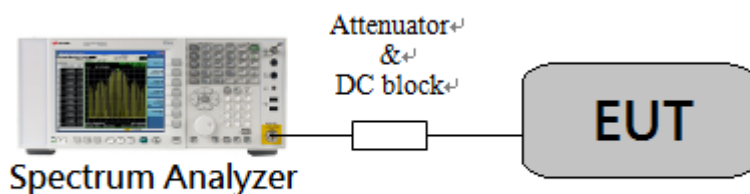

5.4 Limit

The peak output power measured in any 100 kHz bandwidth outside of the authorized frequency band shall be attenuated by at least 20 dB relative to the maximum in-band peak PSD level in 100 kHz

5.5 Operating Environment Condition

Temperature (°C) :	20
Relative Humidity (%) :	58

5.6 Test Results

Chain0 : Conducted Spurious @ 802.11b Mode Ch 1

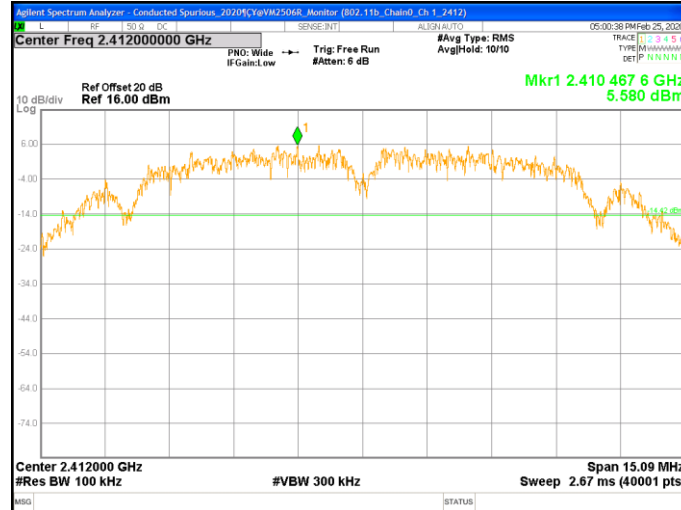

Chain0 : Conducted Spurious @ 802.11b Mode Ch 1

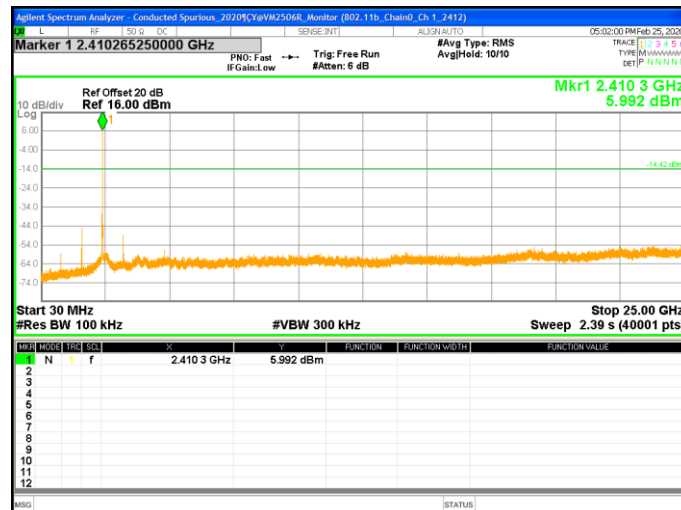

Chain0 : Conducted Spurious @ 802.11b Mode Ch 6

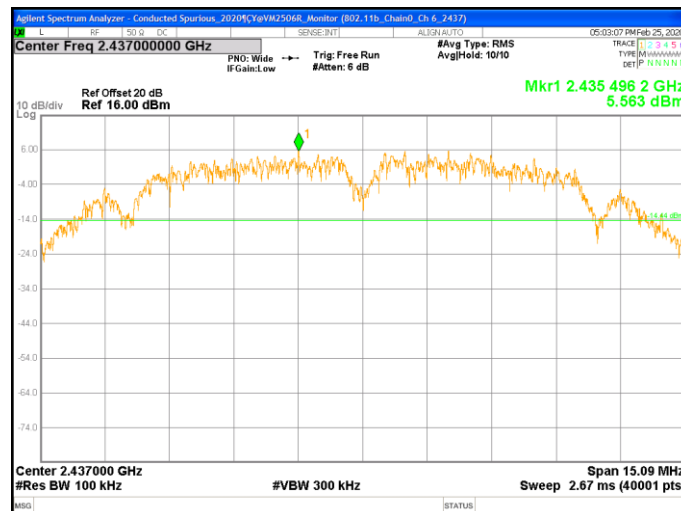

Chain0 : Conducted Spurious @ 802.11b Mode Ch 6

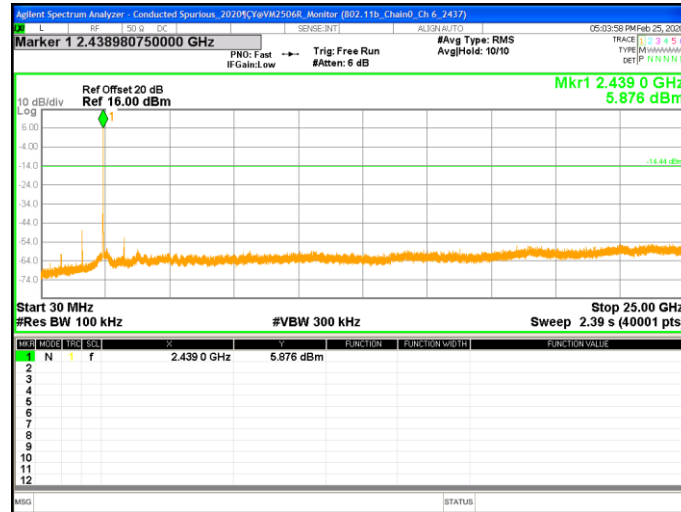

Chain0 : Conducted Spurious @ 802.11b Mode Ch11

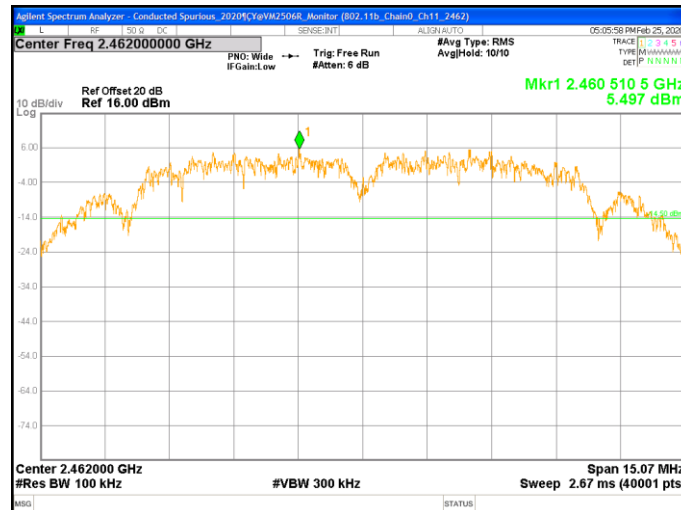

Chain0 : Conducted Spurious @ 802.11b Mode Ch11

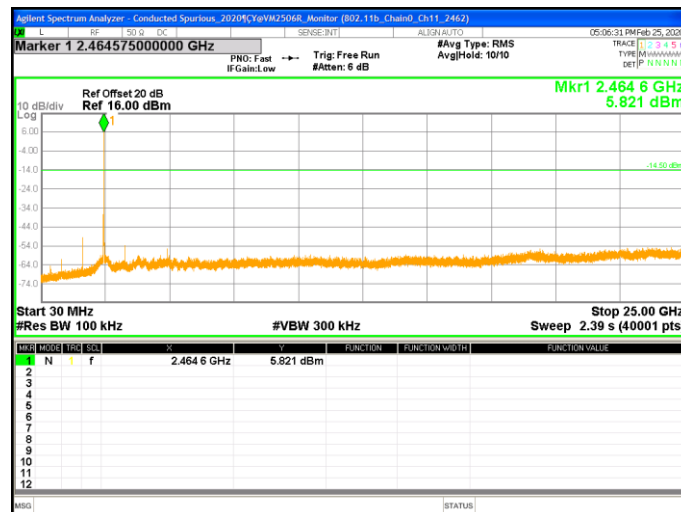

Chain0 : Conducted Spurious @ 802.11g Mode Ch 1

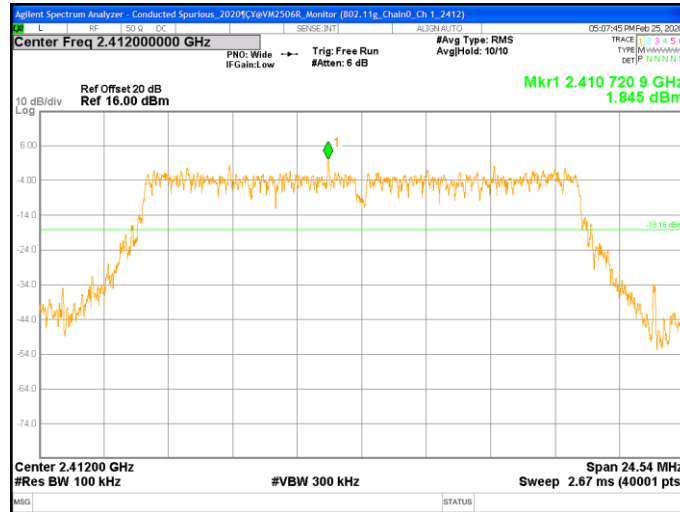

Chain0 : Conducted Spurious @ 802.11g Mode Ch 1

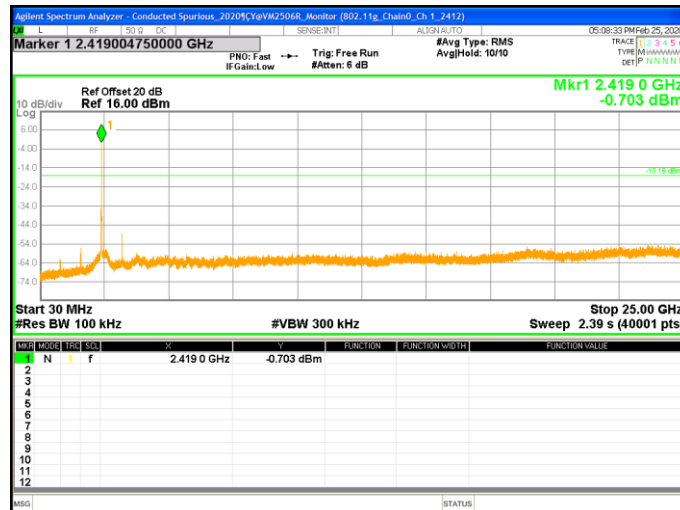

Chain0 : Conducted Spurious @ 802.11g Mode Ch 6

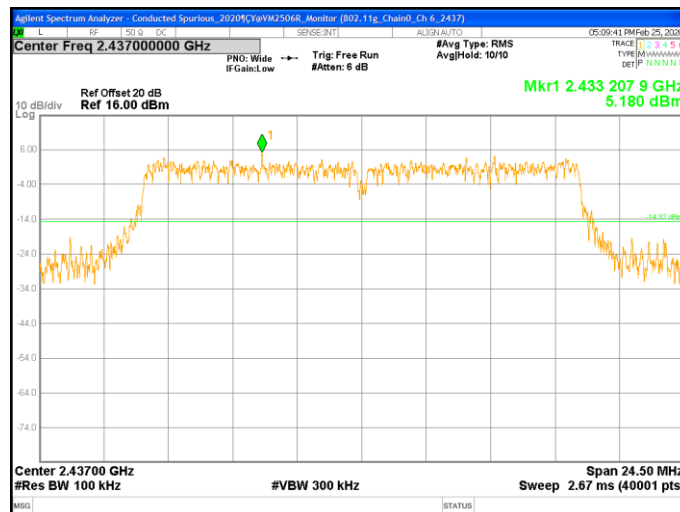

Chain0 : Conducted Spurious @ 802.11n(HT20) Mode Ch 1

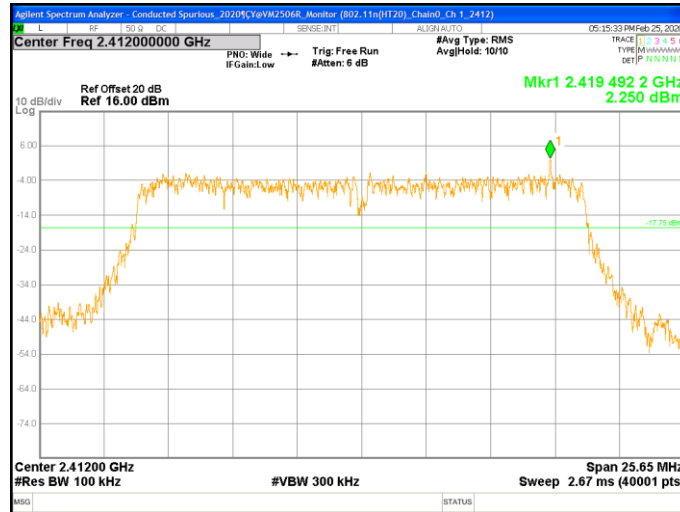

Chain0 : Conducted Spurious @ 802.11n(HT20) Mode Ch 1

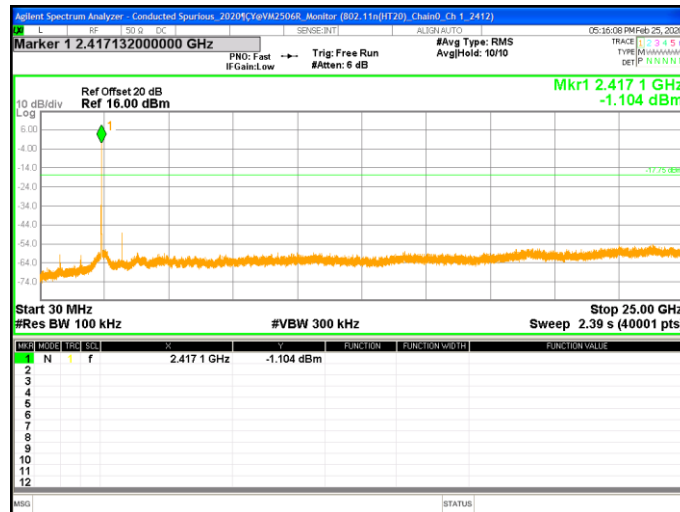

Chain0 : Conducted Spurious @ 802.11n(HT20) Mode Ch 6

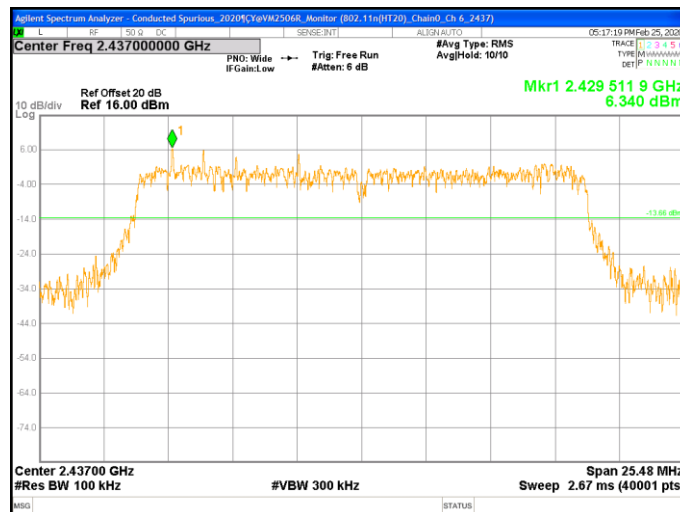

Chain0 : Conducted Spurious @ 802.11n(HT20) Mode Ch 6

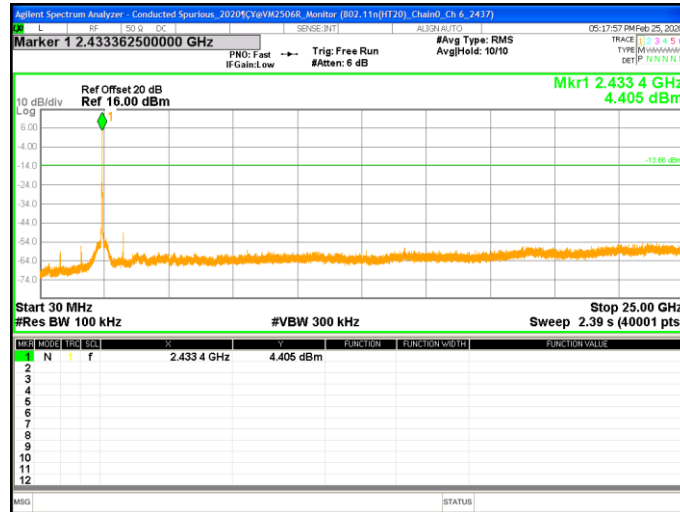

Chain0 : Conducted Spurious @ 802.11n(HT20) Mode Ch11

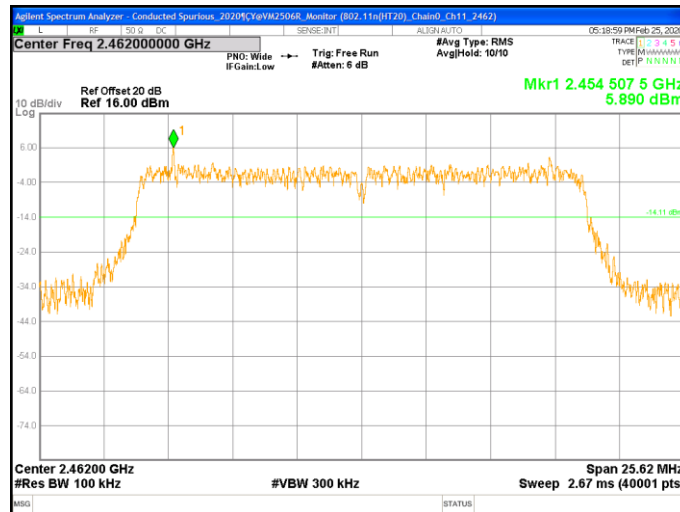

Chain0 : Conducted Spurious @ 802.11n(HT20) Mode Ch11

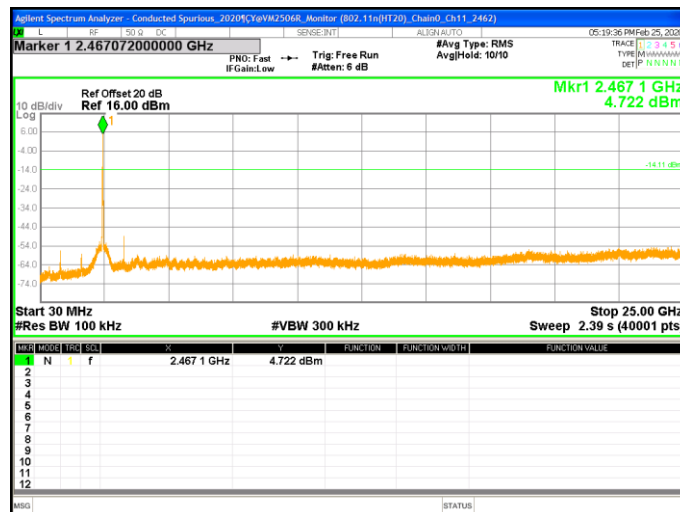

Chain0 : Conducted Spurious @ 802.11n(HT40) Mode Ch 3

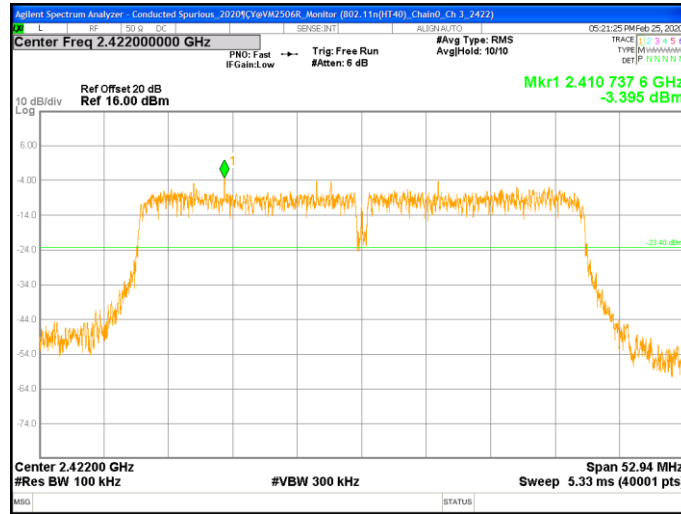

Chain0 : Conducted Spurious @ 802.11n(HT40) Mode Ch 3

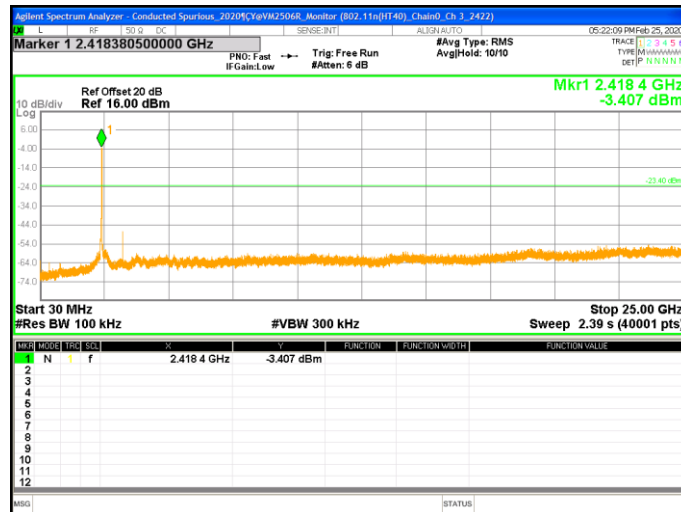

Chain0 : Conducted Spurious @ 802.11n(HT40) Mode Ch 6

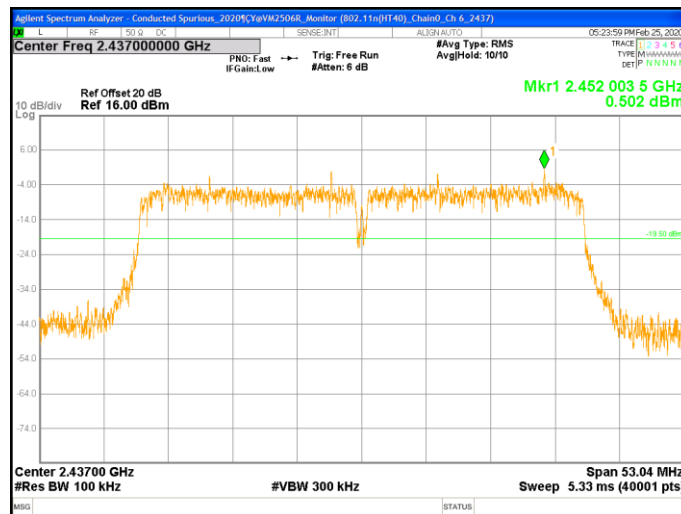

Chain0 : Conducted Spurious @ 802.11n(HT40) Mode Ch 6

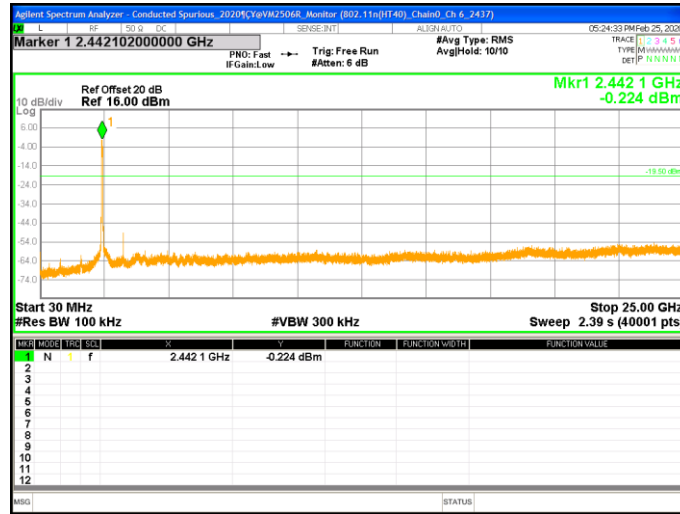

Chain0 : Conducted Spurious @ 802.11n(HT40) Mode Ch 9

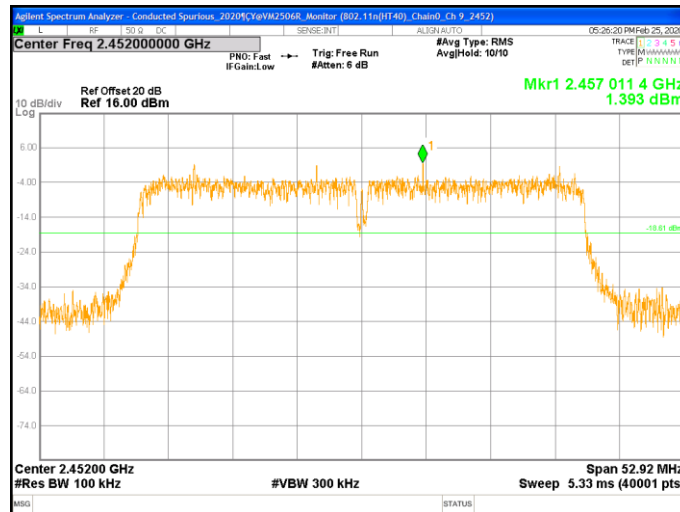

Chain0 : Conducted Spurious @ 802.11n(HT40) Mode Ch 9

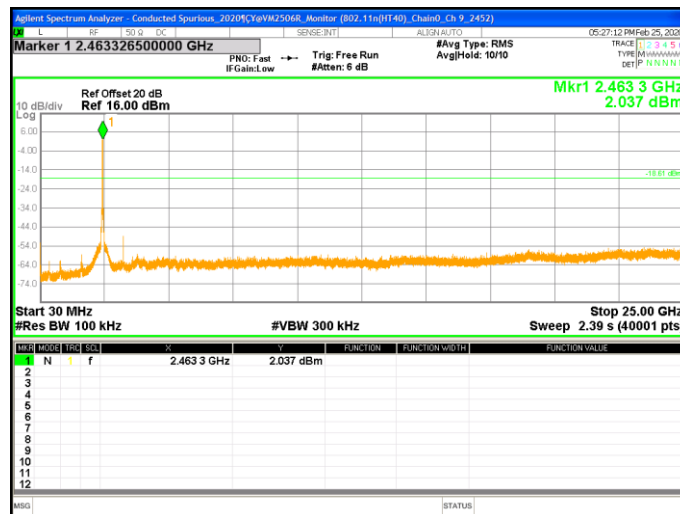

6. Emissions in Restricted Frequency Bands (Radiated emission measurements)

6.1 Instrument Setting

Receiver Function	Setting (Below 1GHz)	Setting (Above 1GHz)
Detector	QP	Peak and Average
RBW	9-150 kHz ; 200-300 Hz 0.15-30 MHz; 9-10 kHz 30-1000 MHz; 100-120 kHz	1MHz
VBW	$\geq 3 \times \text{RBW}$	3MHz
Sweep	Auto couple	Auto couple
Start Frequency	9 kHz	1GHz
Stop Frequency	1 GHz	Tenth harmonic
Attenuation	Auto	Auto

6.2 Test Procedure

Step 1	Configure the EUT according to ANSI C63.10:2013. The EUT was placed on the top of the turntable 0.8 meter (below 1GHz) and 1.5 meter (above 1GHz) above ground. The center of the receiving antenna mounted on the top of a height-variable antenna tower was placed 3 meters far away from the turntable.
Step 2	Power on the EUT and all the companion devices. The turntable was rotated by 360 degree to find the position of the maximum emission level.
Step 3	The height of the receiving antenna was varied between one meter and four meters above ground to find the maximum emission field strength of the both horizontal and vertical polarization.
Step 4	If find the frequencies above the limit or below within 3dB, the antenna tower was scan (from 1m to 4m) and then the turntable was rotated to find the maximum reading.
Step 5	Set the test-receiver system to peak or CISPR quasi-peak detector with specified bandwidth under maximum hold mode.
Step 6	For emissions above 1GHz, use 1MHz VBW and 3MHz RBW for reading in spectrum analyzer. Place the measurement antenna away from each area of the EUT determined to be a source of emissions at the specified measurement distance, while keeping the measurement antenna aimed at the source of emissions at each frequency of significant emissions, with polarization oriented for maximum response.
Step 7	If the emissions level of the EUT in peak mode was 3dB lower than the average limit specified then testing will be stopped and peak values of the EUT will be reported. Otherwise, the emissions which do not have 3dB margin will be measured using the quasi-peak method for below 1GHz.
Step 8	For testing above 1GHz, The emissions level of the EUT in peak mode was lower than average limit, then testing will be stopped and peak values of the EUT will be reported, otherwise, the emission will be measured in average mode again and reported.

TEST REPORT

Step 9	In case the emission is lower than 30MHz, loop antenna has to be used for measurement and the recorded data should be quasi-peak measured by receiver.
--------	--

6.3 Test Diagram

6.3.1 Radiated emission from 9kHz to 30MHz uses Loop Antenna:

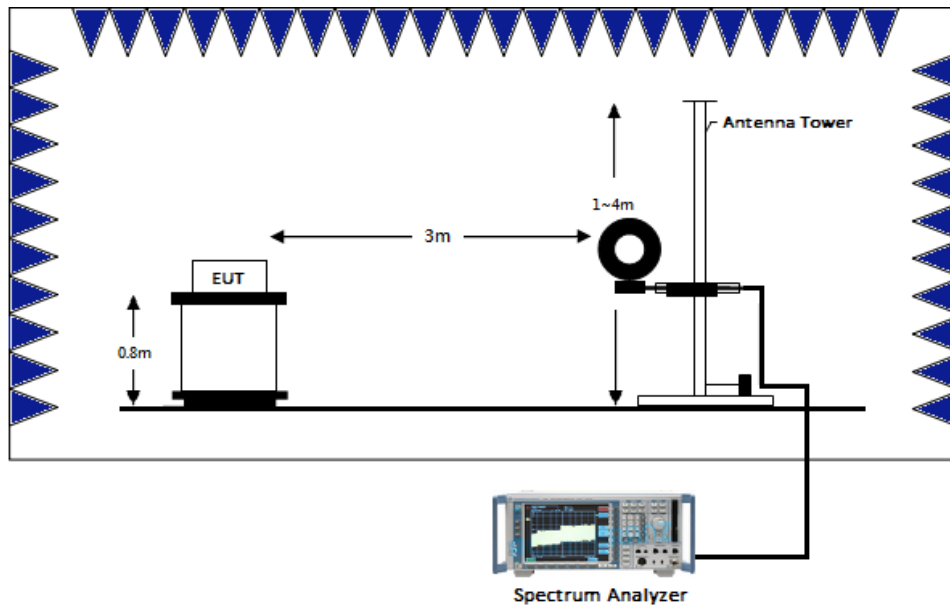

6.3.2 Radiated emission below 1GHz using Bilog Antenna

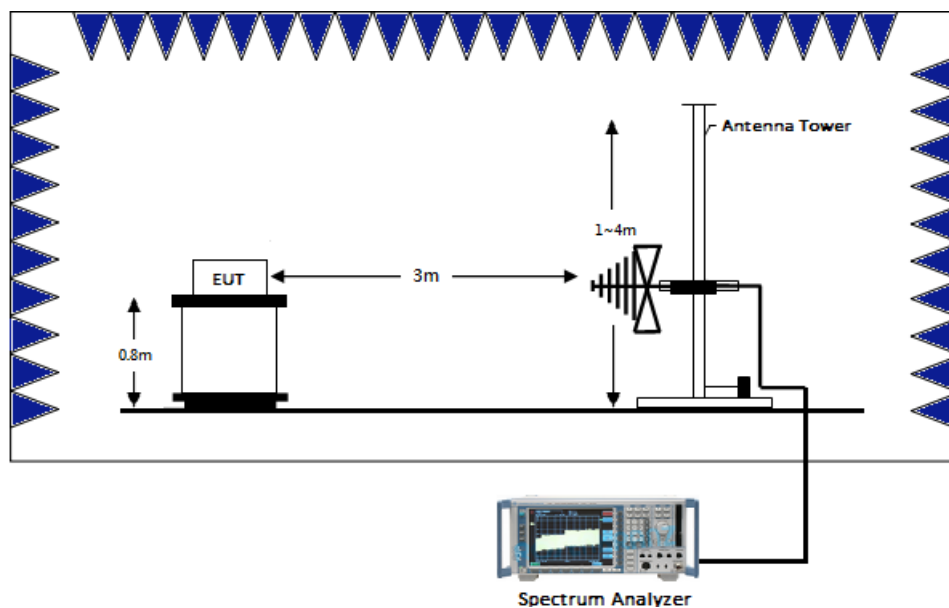

6.3.3 Radiated emission above 1GHz using Horn Antenna

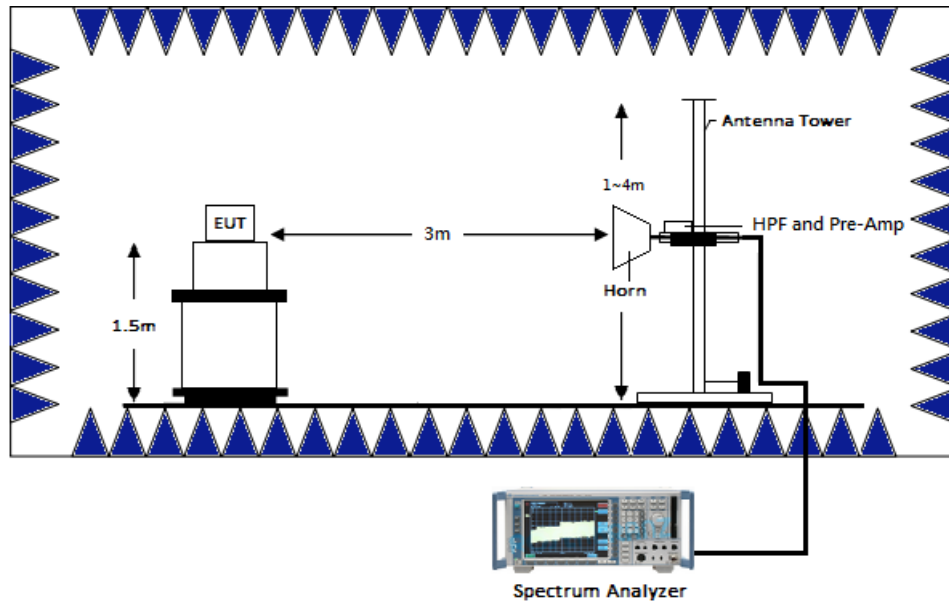

6.4 Limit

Frequency(MHz)	Field Strength(uV/m)	Measurement distance(m)
0.009~0.490	2400/F(kHz)	300
0.490~1.705	24000/F(kHz)	30
1.705~30	30	30
30-88	100	3
88-216	150	3
216-960	200	3
Above 960	500	3

Remark:

1. In the above table, the tighter limit applies at the band edges.
2. Distance refers to the distance in meters between the measuring instrument antenna and the closed point of any part of the device or system

6.5 Operating Environment Condition

Temperature (°C) :	21
Relative Humidity (%) :	58

6.6 Test Result

6.6.1 Measurement results: frequencies 9kHz to 30MHz

The test was performed on EUT under 802.11b/g/n continuously transmitting mode. The worst case occurred at 802.11g Channel 6, Z-axis.

Ant Polarity	Frequency (MHz)	Detector	Factor (dB/m)	Reading (dBμV)	Corrected Reading (dBμV/m)	Limit @ 3m (dBμV/m)	Margin (dB)
Perpendicular	0.01	AV	18.31	47.95	66.26	126.78	-60.52
Perpendicular	0.03	AV	18.51	42.01	60.52	117.78	-57.26
Perpendicular	0.05	AV	18.51	35.34	53.85	114.16	-60.31
Perpendicular	0.06	AV	18.31	34.17	52.48	111.62	-59.14
Perpendicular	0.08	AV	18.32	30.78	49.10	109.76	-60.66
Perpendicular	0.12	AV	18.14	28.74	46.88	106.39	-59.51
Perpendicular	0.54	QP	18.39	29.54	47.93	72.99	-25.06
Perpendicular	0.78	QP	18.56	35.20	53.76	69.80	-16.04
Perpendicular	1.08	QP	18.71	25.86	44.57	66.98	-22.41
Perpendicular	2.27	QP	18.83	20.28	39.11	69.54	-30.43
Perpendicular	7.43	QP	20.40	19.05	39.45	69.54	-30.09
Perpendicular	7.82	QP	20.54	19.89	40.43	69.54	-29.11

Remark: Corr. Factor = Antenna Factor + Cable Loss

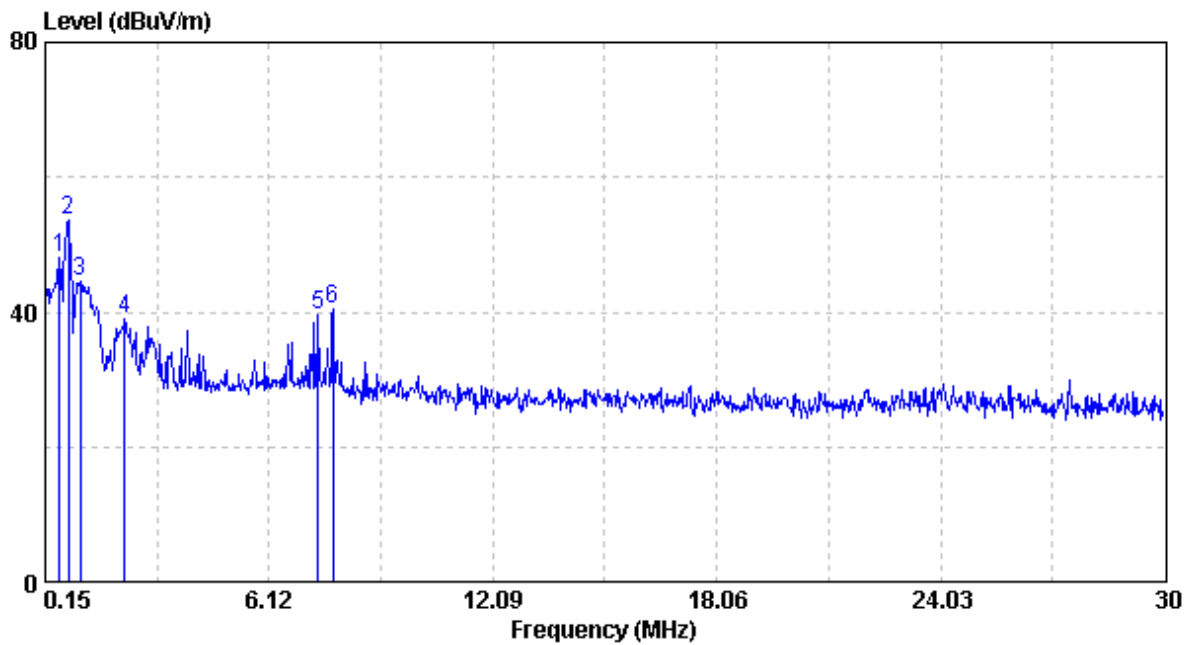
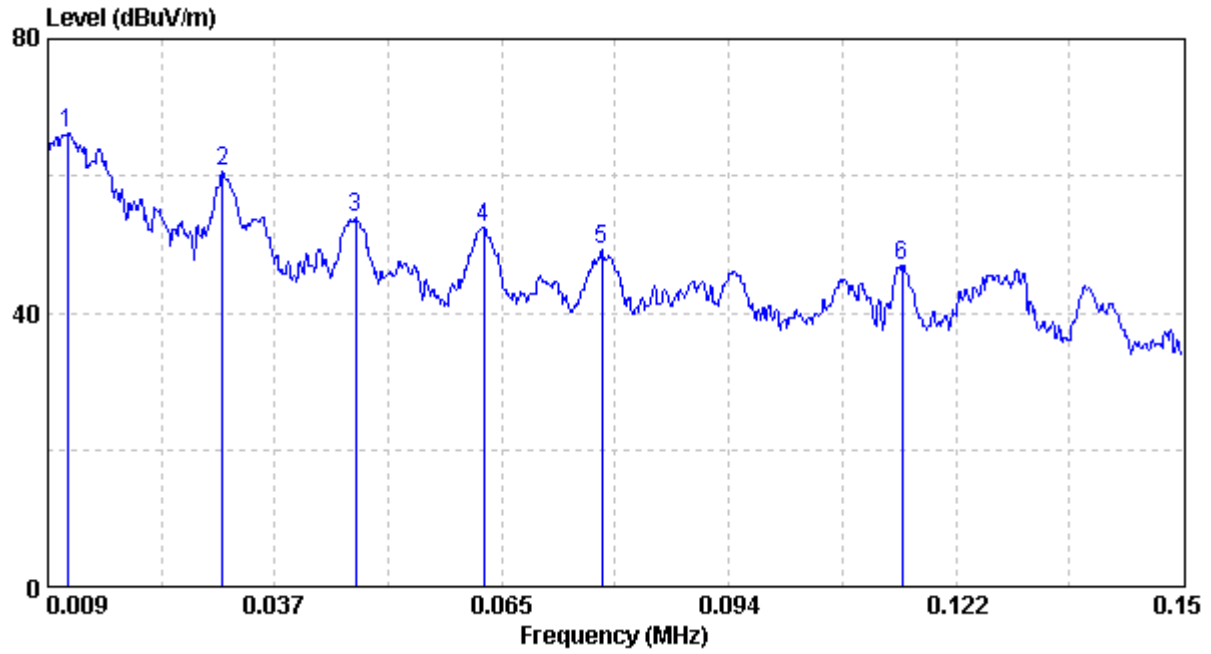

Ant Polarity	Frequency (MHz)	Detector	Factor (dB/m)	Reading (dBμV)	Corrected Reading (dBμV/m)	Limit @ 3m (dBμV/m)	Margin (dB)
Parallel	0.01	AV	18.31	45.22	63.53	127.60	-64.07
Parallel	0.02	AV	18.31	44.13	62.44	123.52	-61.08
Parallel	0.03	AV	18.51	42.15	60.66	118.06	-57.40
Parallel	0.05	AV	18.51	36.22	54.73	114.16	-59.43
Parallel	0.06	AV	18.31	34.22	52.53	111.62	-59.09
Parallel	0.08	AV	18.32	30.96	49.28	109.87	-60.59
Parallel	0.75	QP	18.54	34.42	52.96	70.14	-17.18
Parallel	2.24	QP	18.83	20.80	39.63	69.54	-29.91
Parallel	2.99	QP	18.89	18.49	37.38	69.54	-32.16
Parallel	5.76	QP	19.69	30.74	50.43	69.54	-19.11
Parallel	6.15	QP	19.86	29.27	49.13	69.54	-20.41
Parallel	10.81	QP	21.43	19.01	40.44	69.54	-29.10

Remark: Corr. Factor = Antenna Factor + Cable Loss

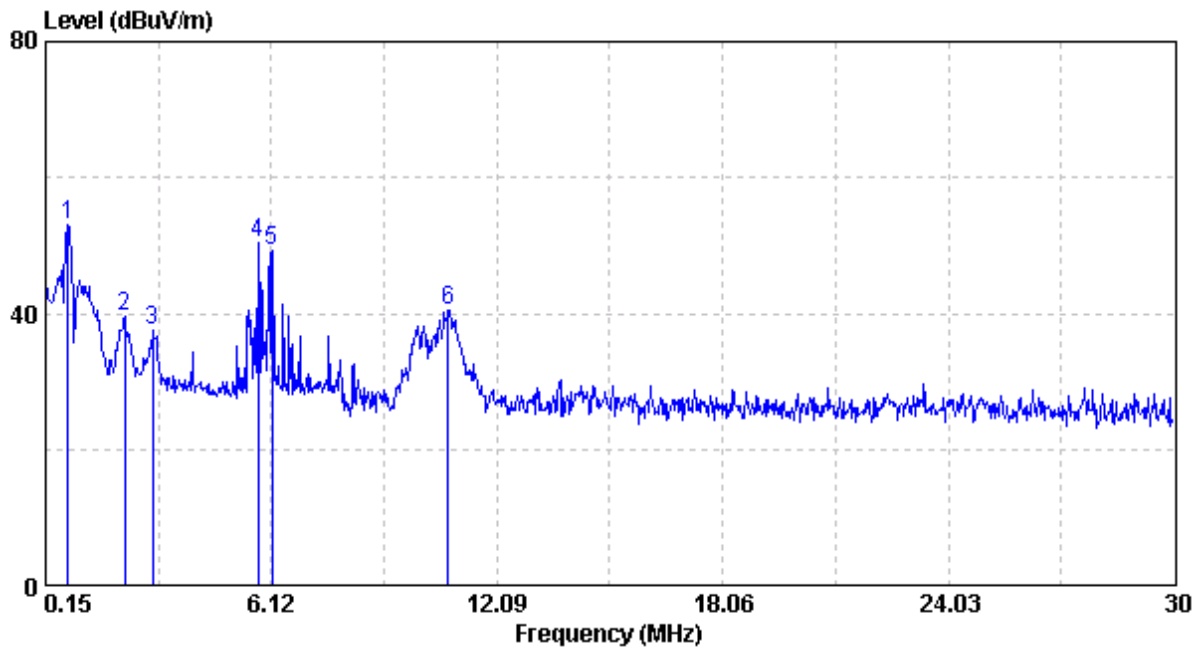
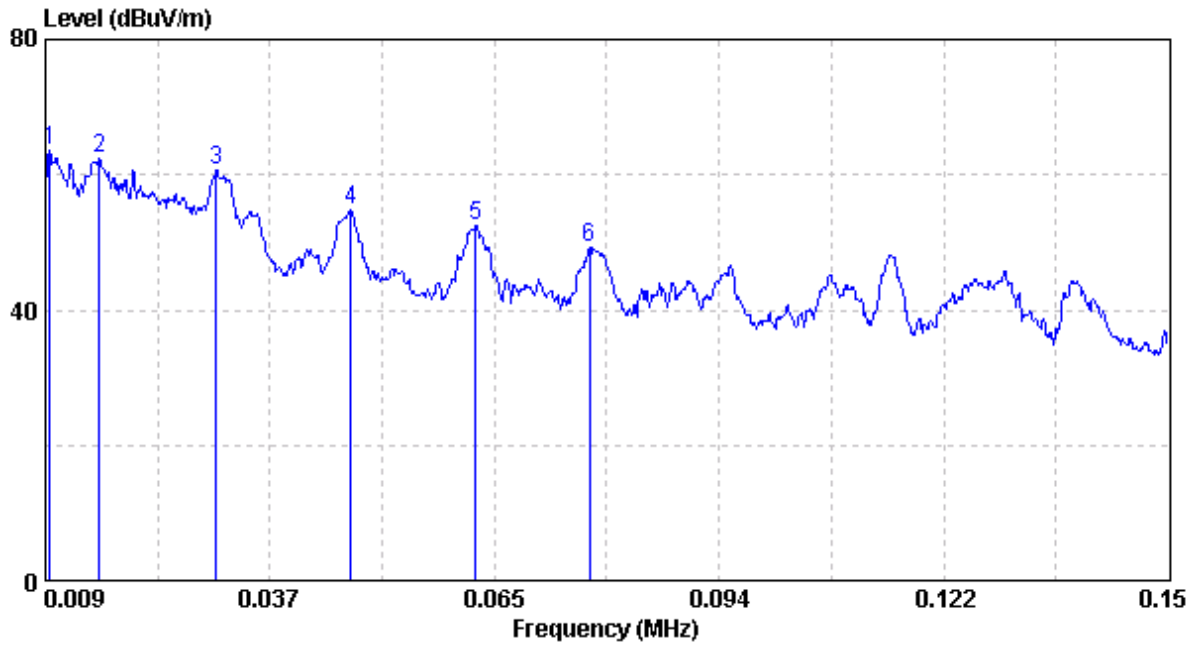

TEST REPORT

Ant Polarity	Frequency (MHz)	Detector	Factor (dB/m)	Reading (dB μ V)	Corrected Reading (dB μ V/m)	Limit @ 3m (dB μ V/m)	Margin (dB)
Ground-parallel	0.01	AV	18.31	53.90	72.21	127.60	-55.39
Ground-parallel	0.03	AV	18.51	41.19	59.70	117.78	-58.08
Ground-parallel	0.04	AV	18.51	42.54	61.05	114.74	-53.69
Ground-parallel	0.06	AV	18.31	36.28	54.59	111.48	-56.89
Ground-parallel	0.08	AV	18.32	31.25	49.57	109.76	-60.19
Ground-parallel	0.12	AV	18.14	30.33	48.47	106.39	-57.92
Ground-parallel	0.78	QP	18.56	35.61	54.17	69.80	-15.63
Ground-parallel	2.24	QP	18.83	20.06	38.89	69.54	-30.65
Ground-parallel	6.06	QP	19.82	25.84	45.66	69.54	-23.88
Ground-parallel	7.94	QP	20.59	20.02	40.61	69.54	-28.93
Ground-parallel	9.94	QP	21.35	16.15	37.50	69.54	-32.04
Ground-parallel	10.87	QP	21.43	19.38	40.81	69.54	-28.73

Remark: Corr. Factor = Antenna Factor + Cable Loss

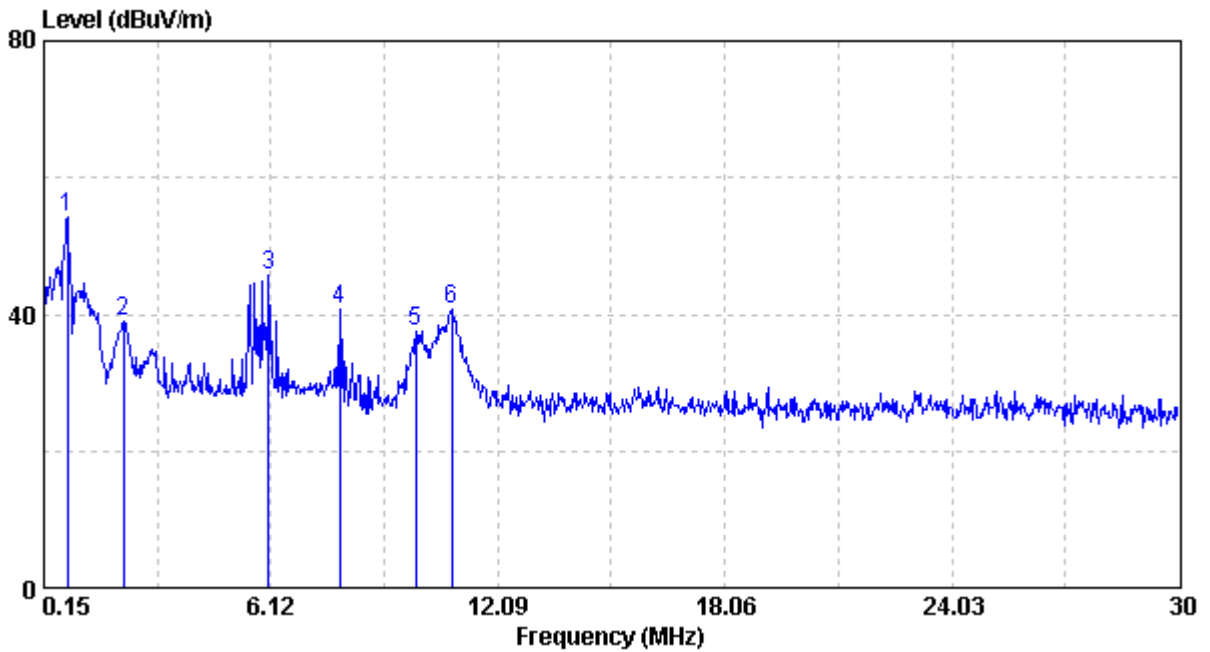
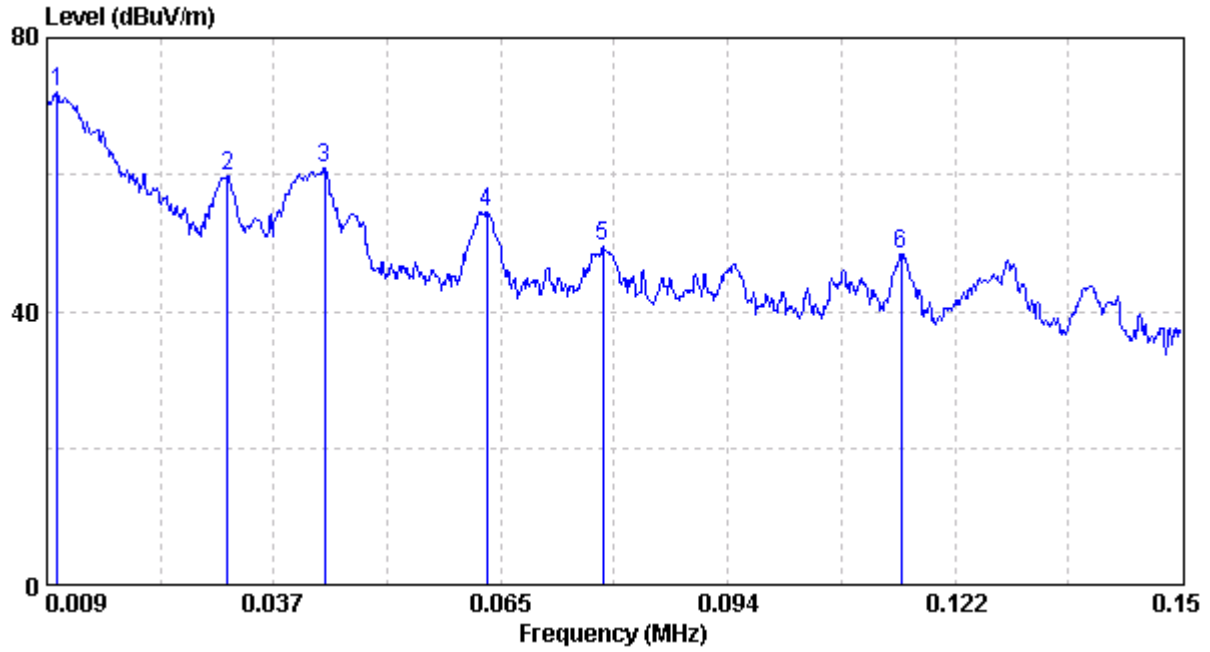

TEST REPORT

6.6.1 Measurement results: frequencies below 1 GHz

The test was performed on EUT under 802.11b/g/n continuously transmitting mode. The worst case occurred at 802.11g Channel 6, Z-axis.

EUT: WF7916

Ant Polarity	Frequency (MHz)	Detector	Factor (dB/m)	Reading (dB μ V)	Corrected Reading (dB μ V/m)	Limit @ 3m (dB μ V/m)	Margin (dB)
Vertical	53.28	QP	15.15	2.30	17.45	40.00	-22.55
Vertical	97.90	QP	17.36	2.10	19.46	43.50	-24.04
Vertical	122.15	QP	18.96	1.89	20.85	43.50	-22.65
Vertical	151.25	QP	19.55	1.98	21.53	43.50	-21.97
Vertical	256.01	QP	21.39	14.20	35.59	46.00	-10.41
Vertical	276.38	QP	22.00	16.80	38.80	46.00	-7.20

Remark: Corr. Factor = Antenna Factor + Cable Loss

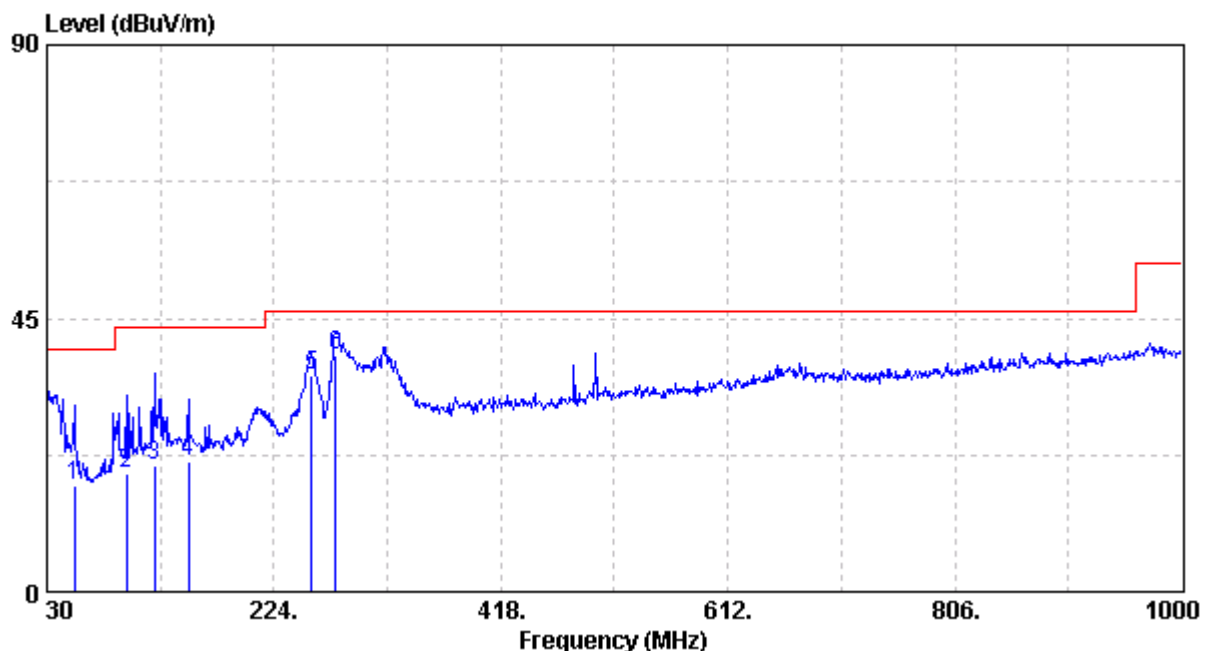

TEST REPORT

Ant Polarity	Frequency (MHz)	Detector	Factor (dB/m)	Reading (dB μ V)	Corrected Reading (dB μ V/m)	Limit @ 3m (dB μ V/m)	Margin (dB)
Horizontal	30.00	QP	26.68	1.40	28.08	40.00	-11.92
Horizontal	123.12	QP	19.06	2.30	21.36	43.50	-22.14
Horizontal	155.13	QP	19.36	2.00	21.36	43.50	-22.14
Horizontal	205.57	QP	20.33	3.21	23.54	43.50	-19.96
Horizontal	254.07	QP	21.35	10.00	31.35	46.00	-14.65
Horizontal	274.44	QP	21.88	15.80	37.68	46.00	-8.32

Remark: Corr. Factor = Antenna Factor + Cable Loss

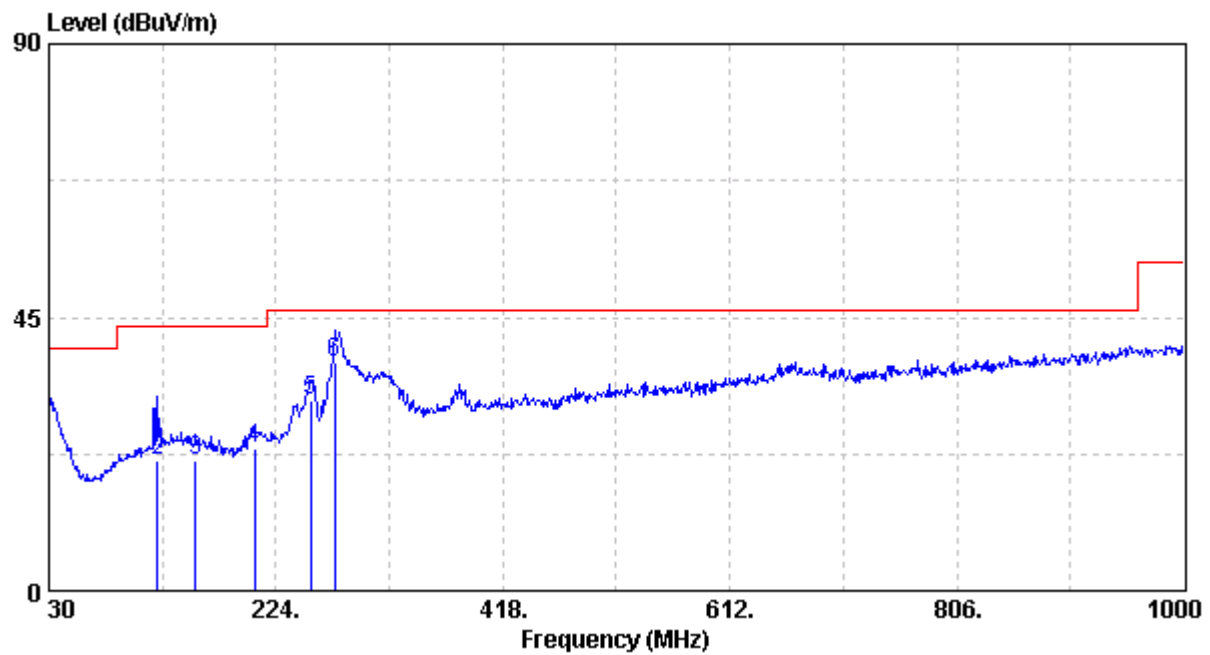

6.6.2 Measurement results: frequency above 1GHz to 25GHz

EUT: WF7916

Mode	Frequency (MHz)	Spectrum Analyzer Detector	Ant. Pol. (H/V)	Correction Factor (dB/m)	Reading (dBμV)	Corrected Reading (dBμV/m)	Limit @ 3 m (dBμV/m)	Margin (dB)
802.11b_Ch1	4824	PK	V	8.87	32.76	41.63	74.00	-32.37
	9648	PK	V	17.25	38.92	56.17	74.00	-17.83
	9648	AV	V	17.25	35.80	53.05	54.00	-0.95
	9648	PK	H	17.25	33.36	50.61	74.00	-23.39
802.11b_Ch6	4874	PK	V	8.98	33.69	42.67	74.00	-31.33
	9748	PK	V	17.68	37.95	55.63	74.00	-18.37
	9748	AV	V	17.68	34.87	52.55	54.00	-1.45
	4874	PK	H	8.98	35.32	44.30	74.00	-29.70
	9748	PK	H	17.68	31.93	49.61	74.00	-24.39
802.11b_Ch11	4924	PK	V	9.08	37.45	46.53	74.00	-27.47
	9848	PK	V	18.12	37.25	55.37	74.00	-18.63
	9848	AV	V	18.12	34.14	52.26	54.00	-1.74
	4924	PK	H	9.08	39.71	48.79	74.00	-25.21
	9848	PK	H	18.12	31.34	49.46	74.00	-24.54
802.11g_Ch1	4824	PK	V	8.87	33.19	42.06	74.00	-31.94
	9648	PK	V	17.25	38.44	55.69	74.00	-18.31
	9648	AV	V	17.25	28.20	45.45	54.00	-8.55
	4824	PK	H	8.87	33.13	42.00	74.00	-32.00
	9648	PK	H	17.25	34.87	52.12	74.00	-21.88
802.11g_Ch6	4874	PK	V	8.98	35.13	44.11	74.00	-29.89
	9748	PK	V	17.68	40.15	57.83	74.00	-16.17
	9748	AV	V	17.68	30.03	47.71	54.00	-6.29
	4874	PK	H	8.98	34.16	43.14	74.00	-30.86
	9748	PK	H	17.68	36.71	54.39	74.00	-19.61
	9748	AV	H	17.68	26.54	44.22	54.00	-9.78
802.11g_Ch11	4924	PK	V	9.08	33.56	42.64	74.00	-31.36
	9848	PK	V	18.12	38.94	57.06	74.00	-16.94
	9848	AV	V	18.12	28.77	46.89	54.00	-7.11
	4924	PK	H	9.08	36.00	45.08	74.00	-28.92
	9848	PK	H	18.12	34.07	52.19	74.00	-21.81

Remark: Correction Factor = Antenna Factor + Cable Loss + High Pass Filter Loss - Pre_Amplifier Gain

TEST REPORT

Mode	Frequency (MHz)	Spectrum Analyzer Detector	Ant. Pol. (H/V)	Correction Factor (dB/m)	Reading (dBμV)	Corrected Reading (dBμV/m)	Limit @ 3 m (dBμV/m)	Margin (dB)
802.11n(HT20)_ Ch1	9648	PK	V	17.25	36.07	53.32	74.00	-20.68
	4824	PK	H	8.87	34.50	43.37	74.00	-30.63
	9648	PK	H	17.25	32.31	49.56	74.00	-24.44
802.11n(HT20)_ Ch6	4874	PK	V	8.98	33.94	42.92	74.00	-31.08
	9748	PK	V	17.68	39.00	56.68	74.00	-17.32
	9748	AV	V	17.68	28.83	46.51	54.00	-7.49
	4874	PK	H	8.98	33.86	42.84	74.00	-31.16
	9748	PK	H	17.68	32.65	50.33	74.00	-23.67
802.11n(HT20)_ Ch11	4924	PK	V	9.08	34.11	43.19	74.00	-30.81
	9848	PK	V	18.12	37.53	55.65	74.00	-18.35
	9848	AV	V	18.12	27.36	45.48	54.00	-8.52
	4924	PK	H	9.08	33.48	42.56	74.00	-31.44
	9848	PK	H	18.12	32.35	50.47	74.00	-23.53
802.11n(HT40)_ Ch3	4844	PK	V	8.91	32.69	41.60	74.00	-32.40
	9688	PK	V	17.42	34.70	52.12	74.00	-21.88
	4844	PK	H	8.91	33.90	42.81	74.00	-31.19
	9688	PK	H	17.42	30.44	47.86	74.00	-26.14
802.11n(HT40)_ Ch6	4874	PK	V	8.98	33.36	42.34	74.00	-31.66
	9748	PK	V	17.68	33.80	51.48	74.00	-22.52
	4874	PK	H	8.98	33.81	42.79	74.00	-31.21
	9748	PK	H	17.68	29.77	47.45	74.00	-26.55
802.11n(HT40)_ Ch9	4904	PK	V	9.04	33.03	42.07	74.00	-31.93
	9808	PK	V	17.94	34.09	52.03	74.00	-21.97
	4904	PK	H	9.04	33.22	42.26	74.00	-31.74
	9808	PK	H	17.94	31.09	49.03	74.00	-24.97

Remark: Correction Factor = Antenna Factor + Cable Loss + High Pass Filter Loss - Pre_Amplifier Gain

7. Emission on Band Edge**7.1 Instrument Setting**

Spectrum Function	Setting
Detector	Peak and Average
RBW	1MHz
VBW	3MHz
Sweep	Auto couple
Restrict bands	2310 MHz ~ 2390 MHz 2483.5 MHz ~ 2500 MHz
Attenuation	Auto

7.2 Test Procedure

The test procedure is the same as Emissions in Restricted Frequency Bands (Radiated emission measurements).

7.3 Operating Environment Condition

Temperature (°C) :	22
Relative Humidity (%) :	59

TEST REPORT

7.4 Test Results

EUT: WF7916

Mode	Frequency (MHz)	Spectrum Analyzer Detector	Ant. Pol. (H/V)	Correction Factor (dB/m)	Reading (dBμV)	Corrected Reading (dBμV/m)	Limit @ 3 m (dBμV/m)	Margin (dB)	Restricted band (MHz)
802.11b	2387.71	PK	H	35.25	23.68	58.93	74	-15.07	2310~2390
	2390.00	AV	H	35.26	10.98	46.24	54	-7.76	
	2483.50	PK	H	35.63	21.51	57.14	74	-16.86	2483.5~2500
	2483.50	AV	H	35.63	8.30	43.93	54	-10.07	
802.11g	2390.00	PK	H	35.26	33.18	68.44	74	-5.56	2310~2390
	2390.00	AV	H	35.26	17.75	53.01	54	-0.99	
	2483.50	PK	H	35.63	36.63	72.26	74	-1.74	2483.5~2500
	2483.62	AV	H	35.63	16.73	52.36	54	-1.64	
802.11n (HT20)	2387.01	PK	H	35.25	32.30	67.55	74	-6.45	2310~2390
	2390.00	AV	H	35.26	18.42	53.68	54	-0.32	
	2487.65	PK	H	35.64	34.80	70.44	74	-3.56	2483.5~2500
	2483.50	AV	H	35.63	17.23	52.86	54	-1.14	
802.11n (HT40)	2390.00	PK	H	35.26	33.70	68.96	74	-5.04	2310~2390
	2390.00	AV	H	35.26	17.39	52.65	54	-1.35	
	2483.50	PK	H	35.63	37.25	72.88	74	-1.12	2483.5~2500
	2483.50	AV	H	35.63	16.63	52.26	54	-1.74	

Remark: Correction Factor = Antenna Factor + Cable Loss

Chain0 : Restricted Band Bandedge @ 802.11b Mode Ch1 PK

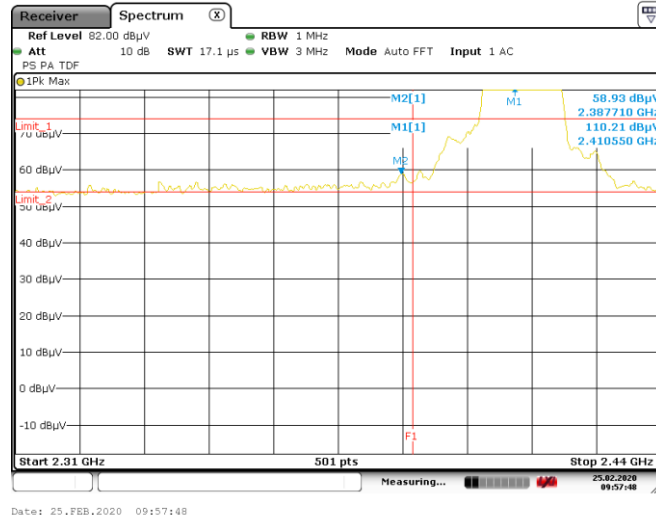

Chain0 : Restricted Band Bandedge @ 802.11b Mode Ch1 AV

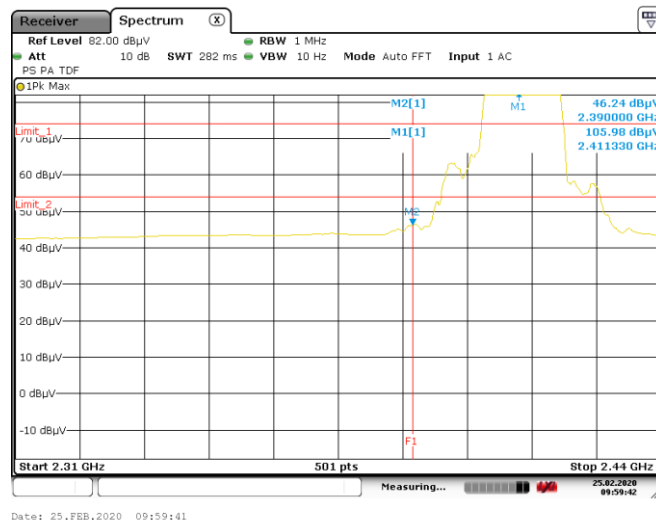

Chain0 : Restricted Band Bandedge @ 802.11b Mode Ch11 PK

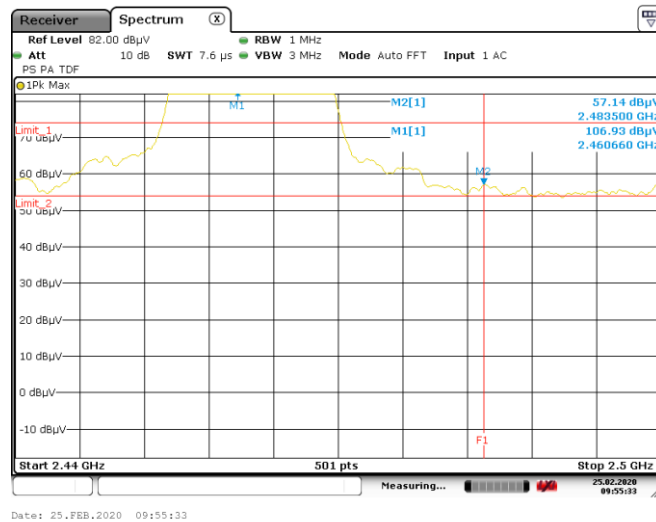

Chain0 : Restricted Band Bandedge @ 802.11b Mode Ch11 AV

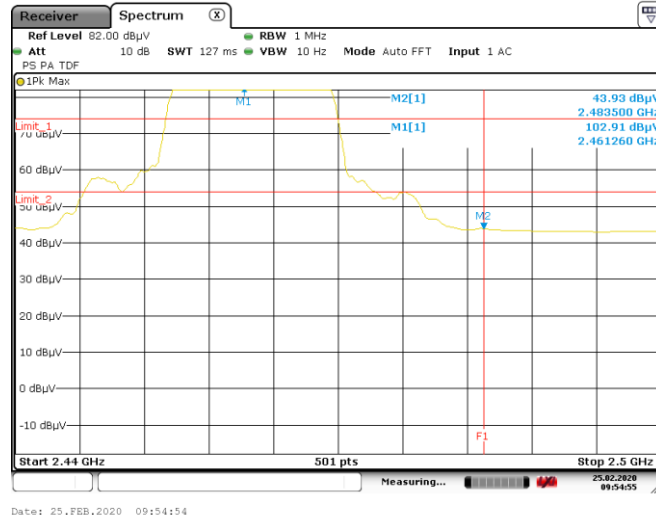

Chain0 : Restricted Band Bandedge @ 802.11g Mode Ch1 PK

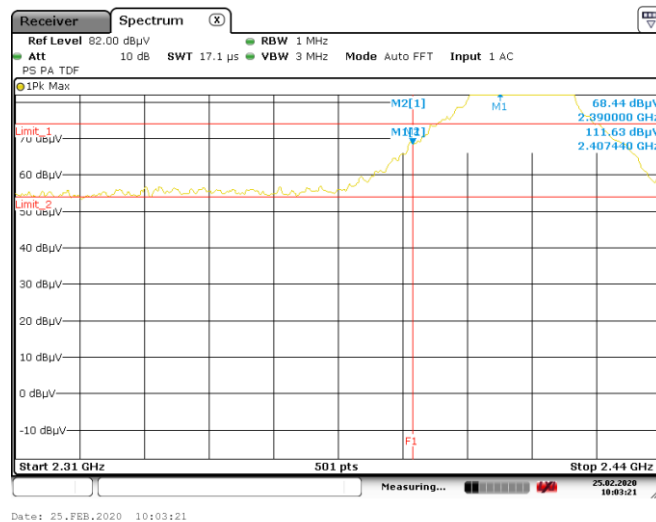

Chain0 : Restricted Band Bandedge @ 802.11g Mode Ch1 AV

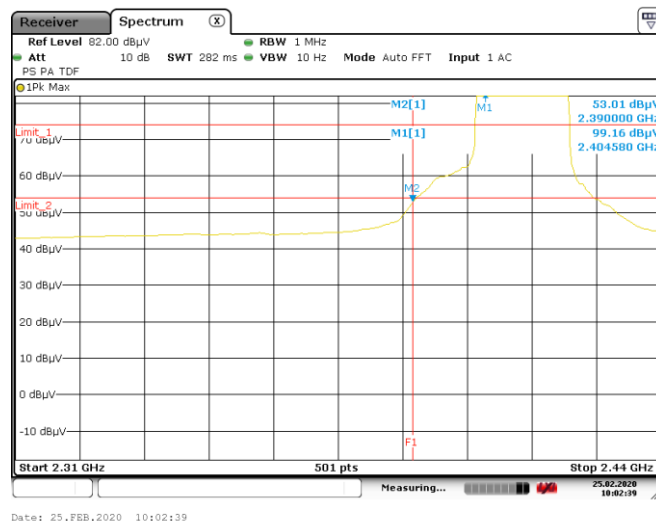

Chain0 : Restricted Band Bandedge @ 802.11g Mode Ch11 PK

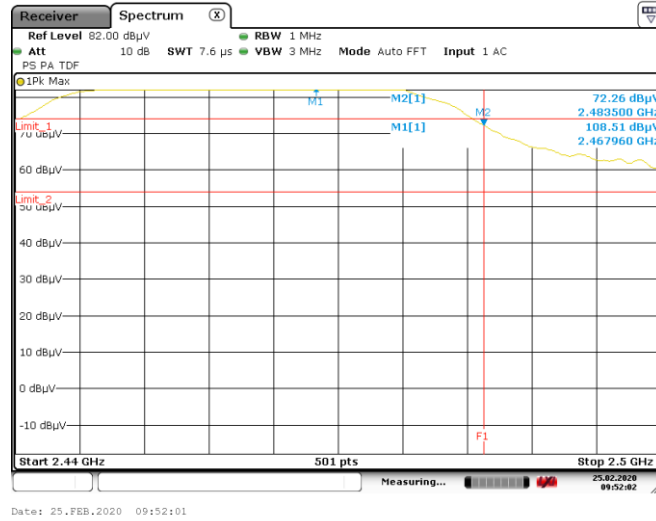

Chain0 : Restricted Band Bandedge @ 802.11g Mode Ch11 AV

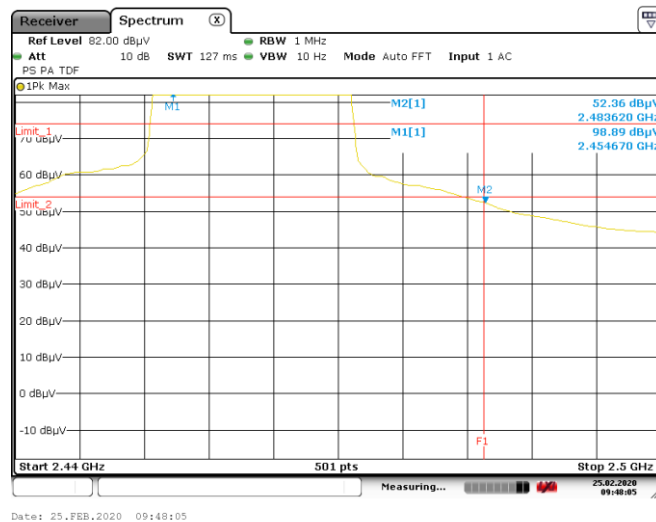

Chain0 : Restricted Band Bandedge @ 802.11n(HT20) Mode Ch1 PK

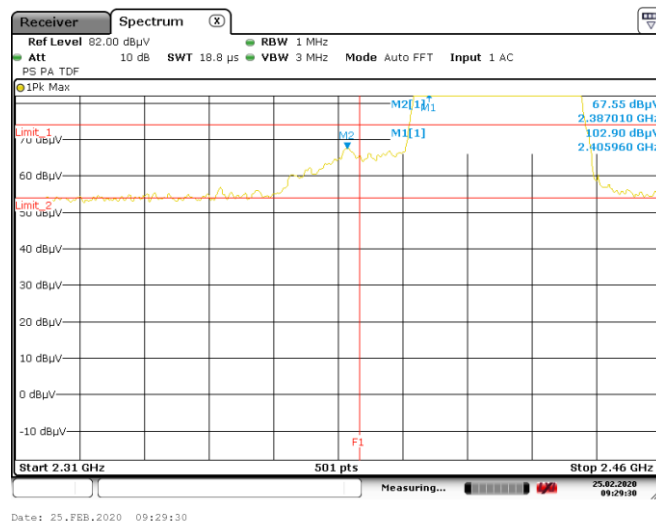

Chain0 : Restricted Band Bandedge @ 802.11n(HT20) Mode Ch1 AV

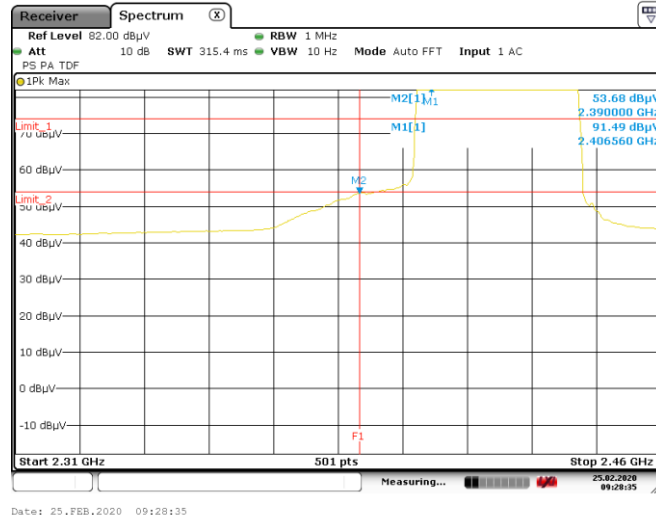

Chain0 : Restricted Band Bandedge @ 802.11n(HT20) Mode Ch11 PK

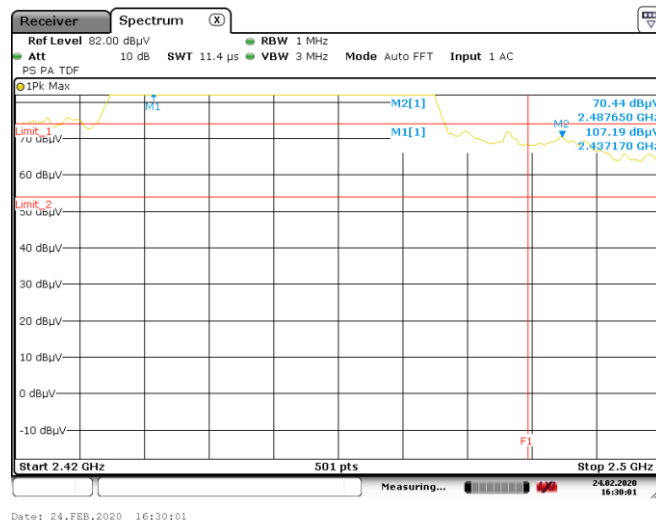

Chain0 : Restricted Band Bandedge @ 802.11n(HT20) Mode Ch11 AV

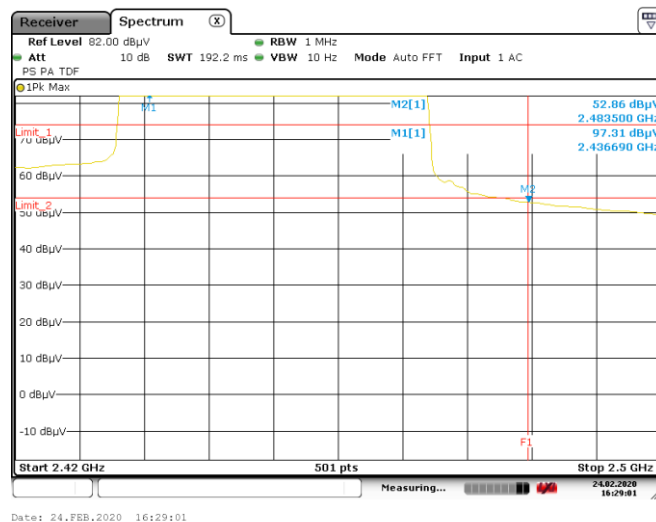

Chain0 : Restricted Band Bandedge @ 802.11n(HT40) Mode Ch3 PK

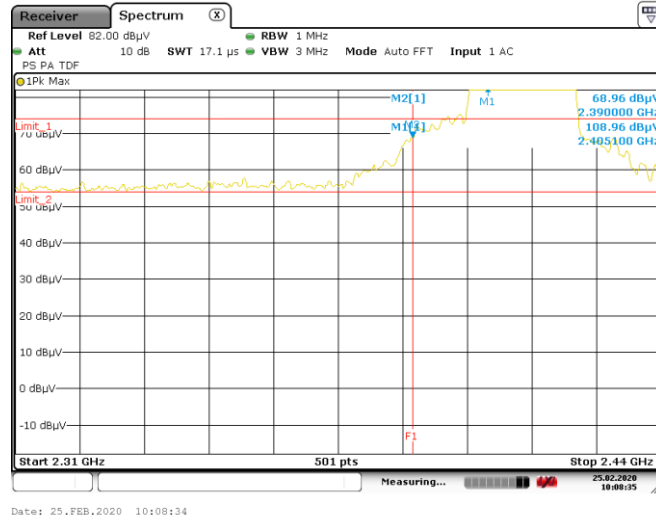

Chain0 : Restricted Band Bandedge @ 802.11n(HT40) Mode Ch3 AV

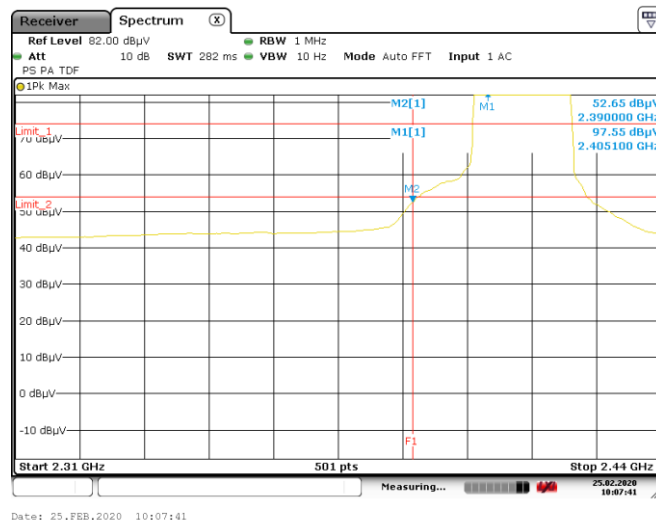

Chain0 : Restricted Band Bandedge @ 802.11n(HT40) Mode Ch9 PK

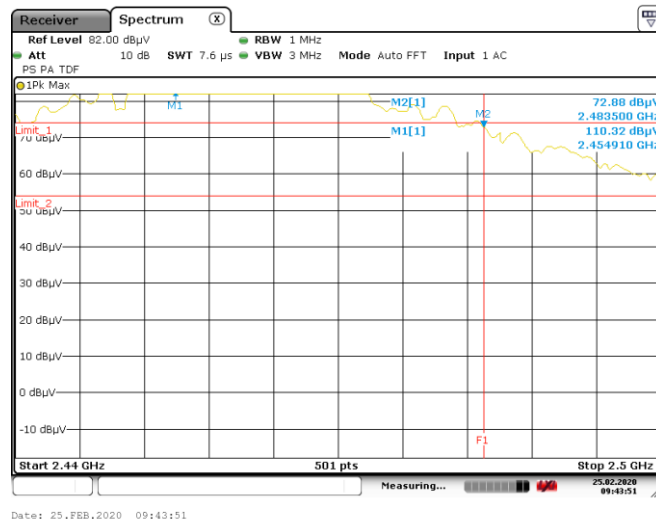

Chain0 : Restricted Band Bandedge @ 802.11n(HT40) Mode Ch9 AV

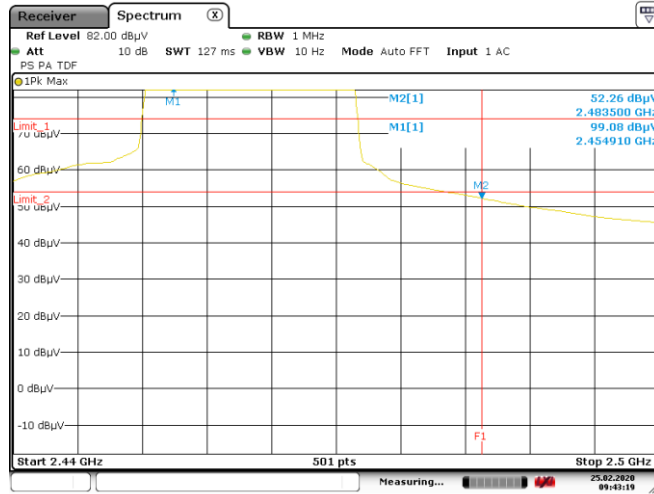

Date: 25 FEB 2020 09:43:19

Chain0 : Authorized Band Bandedge @ 802.11b Mode Ch1



Chain0 : Authorized Band Bandedge @ 802.11b Mode Ch1

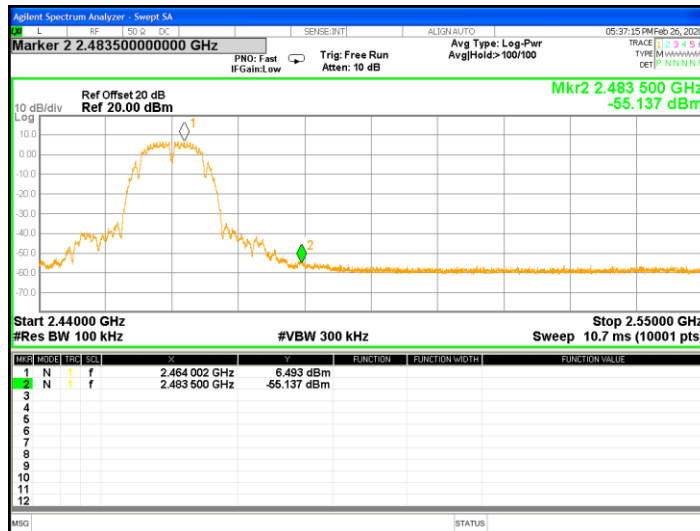

Chain0 : Authorized Band Bandedge @ 802.11g Mode Ch1

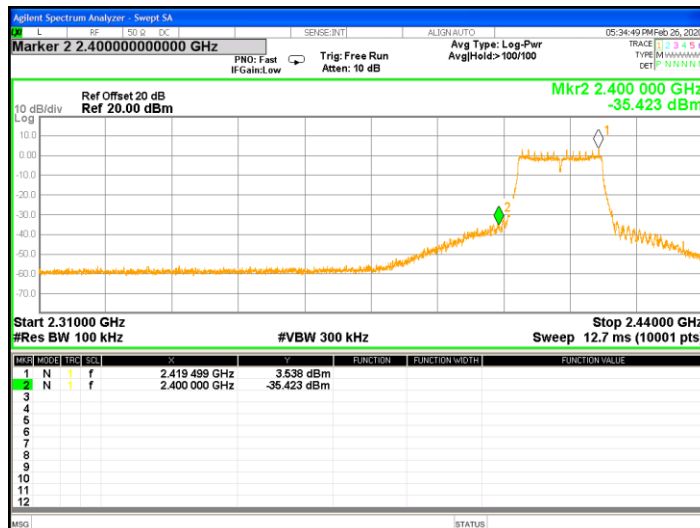

8. AC Power Line Conducted Emission

8.1 Measuring instrument setting

Receiver Function	Setting
Detector	QP
Start frequency	0.15MHz
Stop frequency	30MHz
IF bandwidth	9 kHz
Attenuation	10dB

8.2 Test Procedure

Step 1	Configure the EUT according to ANSI C63.10:2013. The EUT or host of EHT has to be placed 0.4 meter far from the conducting wall of the shielding room and at least 80 centimeters from any other grounded conducting surface.
Step 2	Connect EUT or host of EUT to the power mains through a line impedance stabilization network.
Step 3	All the companion devices are connected to the other LISN. The LISN should provide 50Uh/50ohms coupling impedance.
Step 4	The frequency range from 150 kHz to 30MHz was searched.
Step 5	Set the test-receiver system to peak detector and specified bandwidth with maximum hold mode.
Step 6	The measurement has to be done between each power line and ground at the power terminal.

8.3 Test Diagram

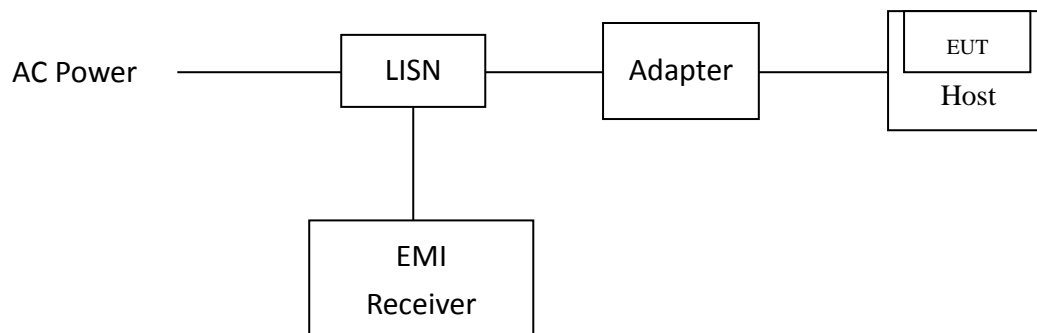

8.4 Limit

Frequency (MHz)	Conducted Limit (dBuV)	
	Q.P.	Ave.
0.15~0.50	66 – 56	56 – 46
0.50~5.00	56	46
5.00~30.0	60	50

8.5 Operating Environment Condition

Temperature (°C) :	21
Relative Humidity (%) :	52
Atmospheric Pressure (hPa) :	1008

TEST REPORT

8.6 Test Results

Phase: Live Line
 Model No.: WF7916
 Test Condition: Tx mode

Frequency (MHz)	Corr. Factor (dB)	Reading QP (dBuV)	Level QP (dBuV)	Limit QP (dBuV)	Reading AV (dBuV)	Level AV (dBuV)	Limit AV (dBuV)	Margin (dB)	
								QP	AV
0.387	9.67	32.33	42.00	58.12	28.29	37.96	48.12	-16.13	-10.16
0.404	9.67	38.59	48.26	57.77	34.62	44.29	47.77	-9.51	-3.48
0.497	9.67	26.95	36.62	56.05	19.13	28.80	46.05	-19.43	-17.25
0.809	9.78	26.76	36.54	56.00	21.07	30.86	46.00	-19.46	-15.14
1.117	9.83	24.79	34.62	56.00	17.34	27.17	46.00	-21.38	-18.83
1.819	9.84	23.83	33.67	56.00	17.66	27.50	46.00	-22.33	-18.50

Remark:

1. Corr. Factor (dB) = LISN Factor (dB) + Cable Loss (dB)
2. Level (dBuV) = Corr. Factor (dB) + Reading (dBuV)
3. Margin (dB) = Level (dBuV) – Limit (dBuV)

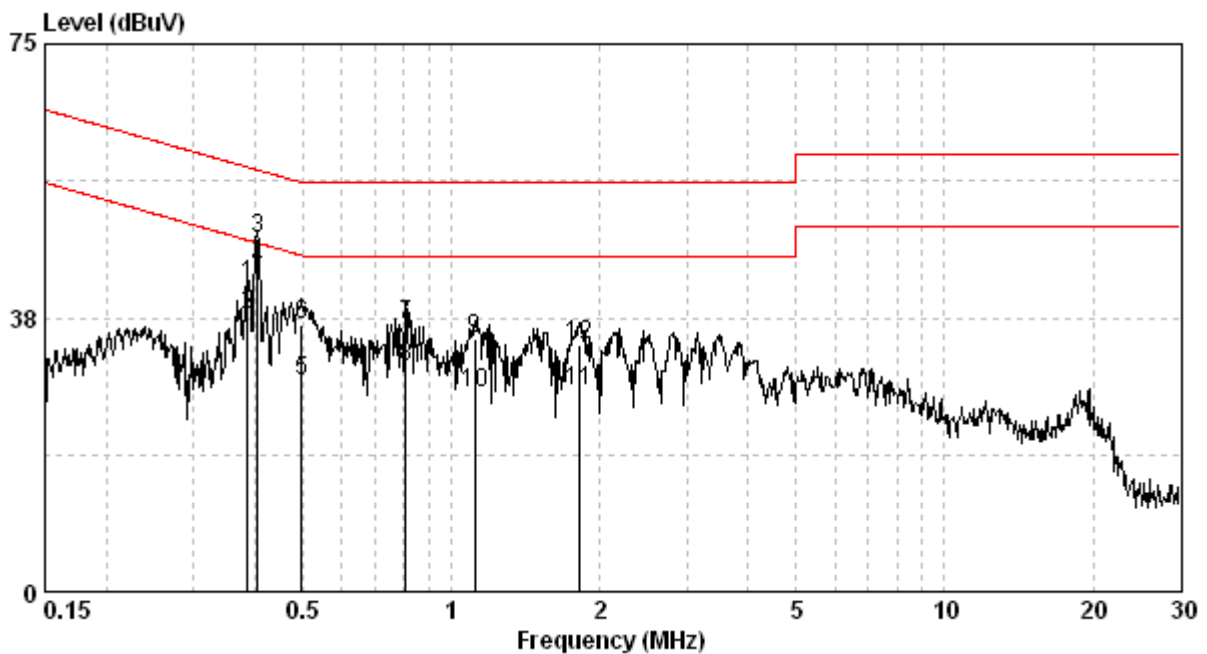

TEST REPORT

Phase: Neutral Line
 Model No.: WF7916
 Test Condition: Tx mode

Frequency (MHz)	Corr. Factor (dB)	Reading QP (dBuV)	Level QP (dBuV)	Limit QP (dBuV)	Reading AV (dBuV)	Level AV (dBuV)	Limit AV (dBuV)	Margin (dB)	
								QP	AV
0.385	9.67	31.40	41.07	58.17	25.48	35.14	48.17	-17.10	-13.02
0.402	9.67	36.15	45.82	57.81	29.91	39.58	47.81	-12.00	-8.23
0.476	9.67	25.31	34.99	56.41	16.43	26.10	46.41	-21.42	-20.31
0.516	9.68	23.00	32.68	56.00	13.76	23.44	46.00	-23.32	-22.56
0.809	9.79	24.12	33.90	56.00	15.42	25.21	46.00	-22.10	-20.79
0.994	9.84	18.10	27.94	56.00	9.65	19.49	46.00	-28.06	-26.51

Remark:

1. Corr. Factor (dB) = LISN Factor (dB) + Cable Loss (dB)
2. Level (dBuV) = Corr. Factor (dB) + Reading (dBuV)
3. Margin (dB) = Level (dBuV) – Limit (dBuV)

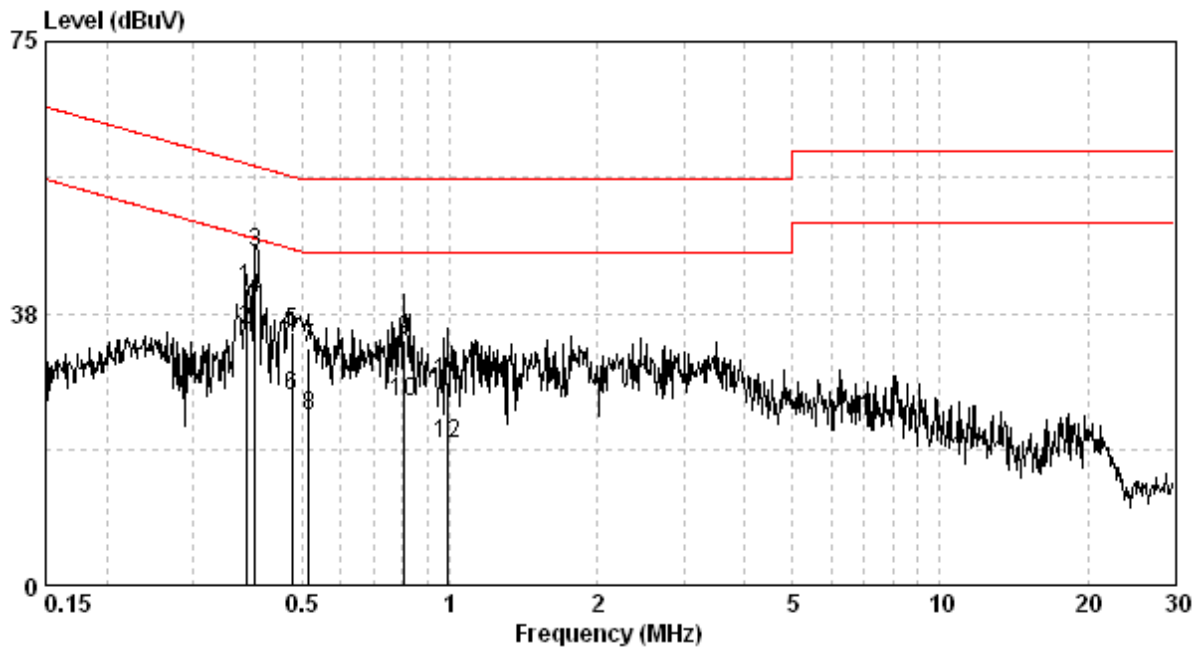

Appendix A: Test equipment list

Test Equipment/ Test site	Brand	Model No.	Serial No.	Calibration Date	Next Calibration Date
EMI Test Receiver	R&S	ESR7	101232	2020/01/18	2021/01/16
Signal Analyzer	Agilent	N9030A	MY51380492	2019/08/21	2020/08/19
Horn Antenna	SHWARZBECK	BBHA 9120 D	9120D-456	2020/01/20	2021/01/18
Power Meter	Anritsu	ML2495A	0844001	2019/10/23	2020/10/21
Power Sensor	Anritsu	MA2411B	0738452	2019/10/23	2020/10/21
966-2(A) Cable	SUHNER	SMA / EX 100	N/A	2019/08/19	2020/08/17
966-2(B) Cable	SUHNER	SUCOFLEX 104P	CB0005	2019/08/19	2020/08/17
RF Cable	SUHNER	SUCOFLEX 102	CB0006	2019/05/02	2020/04/30
Hight Pass Filter	Wainwright	WHKX3.0/18G-12 SS	N/A	2019/05/30	2020/05/28
966-2_3m Semi-Anechoic Chamber	966_2	CEM-966_2	N/A	2020/02/22	2021/02/21
EMI Receiver	R&S	ESU40	100381	2019/06/05	2020/06/03
Active Loop Antenna	SCHWARZBECK MESS-ELEKTRONIC	FMZB1519	1519-067	2019/04/19	2020/04/17
Bi-log Hybrid Antenna	ETC	MCTD2786	BL13S03017	2019/06/27	2020/06/25
966-1(A) Cable	SUHNER	SMA / SUCOFLEX 104	29510614	2019/04/15	2020/04/13
966-1(B) Cable	JUNFLON	SMA / J12J100880-00	AUG-26-08-001	2019/04/15	2020/04/13
966-1_3m Semi-Anechoic Chamber	966_1	CEM-966_1	N/A	2019/03/04	2020/03/02
Test software	Audix	e3	4.20040112L	NCR	NCR

Note: No Calibration Required (NCR)

TEST REPORT

Test Equipment/ Test site	Brand	Model No.	Serial No.	Calibration Date	Next Calibration Date
EMI Test Receiver	R&S	ESR7	101822	2019/06/19	2020/06/17
Two-Line V-Network	R&S	ENV216	101160	2019/07/17	2020/07/15
Two-Line -V-Network	R&S	ESH3-Z5	838979/014	2019/09/24	2020/09/22
CON-2 Shielded Room	N/A	N/A	N/A	NCR	NCR
CON-2 Cable	SUHNER	EMCCFD300-B M-NM-6000	170502	2019/05/06	2020/05/04
Test software	Audix	e3	4.20040112L	NCR	NCR

Note: No Calibration Required (NCR).

Appendix B: Measurement Uncertainty

This uncertainty represents an expanded uncertainty expressed at approximately the 95 % confidence level using a coverage factor of k=2.

Item	Uncertainty
Vertically polarized radiated disturbances from 30MHz~1GHz in a semi-anechoic chamber at a distance of 3m	4.90 dB
Horizontally polarized radiated disturbances from 30MHz~1GHz in a semi-anechoic chamber at a distance of 3m	4.89 dB
Vertically polarized Radiated disturbances from 1GHz~18GHz in a semi-anechoic chamber at a distance of 3m	4.29 dB
Horizontally polarized Radiated disturbances from 1GHz~18GHz in a semi-anechoic chamber at a distance of 3m	4.29 dB
Vertically polarized Radiated disturbances from 18GHz~26.5GHz in a semi-anechoic chamber at a distance of 1m	2.45 dB
Horizontally polarized Radiated disturbances from 18GHz~26.5GHz in a semi-anechoic chamber at a distance of 1m	2.45 dB
Radiated disturbances from 9kHz~30MHz in a semi-anechoic chamber at a distance of 3m	3.32 dB
Emission on the Band Edge Test	4.29 dB
Minimum 6 dB Bandwidth	7.69 %
Maximum Peak Conducted Output Power	0.37 dB
Power Spectral Density	1.15 dB
Emissions In Non-Restricted Frequency Bands	1.15 dB
AC Power Line Conducted Emission	2.52 dB