



Test Report

Product Name: RF cordless Mouse

Model No. : RF11-TP-M,RF11-GP-M

FCC ID. : O62 RF-TP-GP-M

Applicant : Darfon Electronics Corp.

Address : 6, Feng-Shu Tsuen, Gueishan,
Taoyuan 333, Taiwan, R.O.C.

Date of Receipt : November 06, 2001

Date of Test : November 26, 2001

Report No. : 01BL027FI

The Test Results relate only to the samples tested.

The test report shall not be reproduced except in full without the written approval of Quietek Corporation.

This report must not be used to claim product endorsement by NVLAP any agency of the U.S. Government

Test Report Certification

Test Date : November 26, 2001

Report No.: 01BL027FI

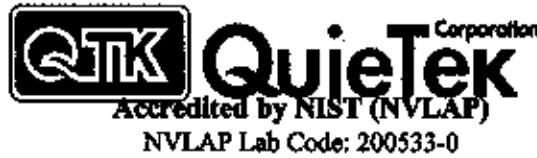

Product Name : RF cordless Mouse

Applicant : Darfon Electronics Corp.

Address : 6, Feng-Shu Tsuen, Gueishan, Taoyuan 333, Taiwan,
R.O.C.

Manufacturer : Darfon Electronics Corp.

Model No. : RF11-TP-M,RF11-GP-M

FCC ID. : O62 RF-TP-GP-M

Rated Voltage : DC 3V (Battery)

Trade Name : Acer, Benq

Measurement Standard : FCC Part 15 Intentional Radiators for Subpart C
Paragraph 15.227

Measurement Procedure : ANSI C63.4:1992

Test Result : Complied



The Test Results relate only to the samples tested.

The test report shall not be reproduced except in full without the written approval of Quietek Corporation.

This report must not be used to claim product endorsement by NVLAP any agency of the U.S. Government

Documented By : Melody Hsu
(Melody Hsu)

Tested By : Tony Hsieh
(Tony Hsieh)

Approved By : Gene Chang
(Gene Chang)

TABLE OF CONTENTS

Description	Page
1. GENERAL INFORMATION.....	4
1.1. EUT Description	4
1.2. Operation Description	4
1.3. Tested System Details	5
1.4. Configuration of tested System.....	5
1.5. EUT Exercise Software.....	6
1.6. Test Facility	6
2. Conducted Emission	7
2.1. Test Equipment List	7
2.2. Test Setup	7
2.3. Limits	8
2.4. Test Procedure	8
2.5. Test Result.....	8
3. Radiated Emission.....	9
3.1. Test Equipment	9
3.2. Test Setup	9
3.3. Limits	10
3.4. Test Procedure.....	11
3.5. Test Result.....	11
4. EMI Reduction Method During Compliance Testing	12
5. Summary of Test Datas.....	13
5.1. Test Data of Conducted Emission	14
5.2. Test Data of Radiated Emission	15

Attachment 1: EUT Test Photographs

Attachment 2: EUT Detailed Photographs

1. GENERAL INFORMATION

1.1. EUT Description

Product Name	RF cordless Mouse
Trade Name	Acer, Benq
FCC ID.	O62 RF-TP-GP-M
Model No.	RF11-TP-M,RF11-GP-M
EUT Voltage	DC 3V (Battery)
Frequency Range	27MHz
Type of Modulation	FM
Type of antenna	Loop antenna

Note:

1. The EUT is a RF cordless Mouse intend to use in household and office PC system or related application.
2. The EUT (TX) have two models, the different of them as shown below table:

Model Number (TX)	Color
RF11-TP-M	Black
RF11-GP-M	White

3. These tests were conducted on a sample of the equipment for the purpose of demonstrating compliance with Part 15 Subpart C Paragraph 15.227.
4. This device is a composite device in accordance with Part 15 regulations. The function for the receiver was measured and made a test report that the report number is 01BL027F certified under verification.

1.2. Operation Description

The EUT is a 27MHz RF cordless Mouse intends to use in household and office PC system.

The transmission antenna is Loop antenna.

The super generations type receiver was used. An external excitation was used when the test of receiver was performed.

1.3. Tested System Details

The types for all equipment, plus descriptions of all cables used in the tested system (including inserted cards) are:

	Product	Manufacturer	Model No.	Serial No.	FCC ID
(1)	PC	IBM	2187-16W	BNL6766	DoC
(2)	Monitor	ADI	CM703	038054T10203876A	DoC
(3)	Modem	ACEEX	DM-1414	0102027552	IFAXDM1414
(4)	USB Keyboard	BTC	5200U	N/A	E5XKB5122U
(5)	USB Mouse	Logitech	M-BE58	LZE11405306	DoC
(6)	Printer	EPSON	Color 680	015256	DoC

Note: 1. The power cord of the device 1, 2, 3 and 6 are Non-shielded power cord.

	Signal Cable Type	Signal cable Description
A.	Modem cable	Shielded, 1.2m
B.	Monitor cable	Shielded, 1.8m, a ferrite cord bonded
C.	USB keyboard cable	Shielded, 1.5m
D.	USB mouse cable	Shielded, 1.5m
E.	Signal cable (Rx)	Shielded, 1.2m
F.	Printer cable	Non-Shielded, 1.5m

1.4. Configuration of tested System

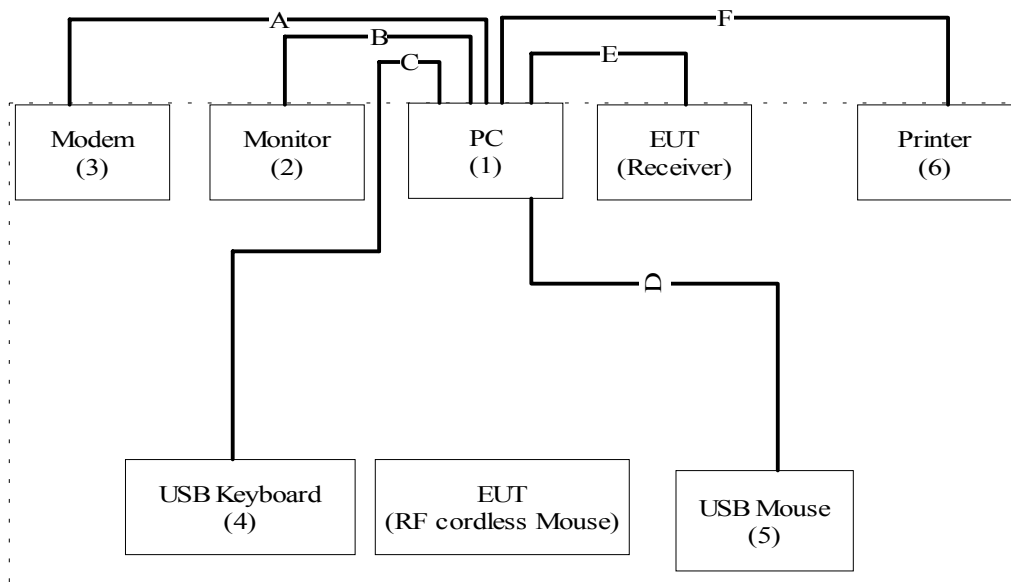

1.5. EUT Exercise Software

- (1) Setup the EUT and simulators as shown on 1.3.
- (2) Enable RF signal and confirm EUT active.
- (3) Modulate output capacity of EUT up to specification.

1.6. Test Facility

Ambient conditions in the laboratory:

Items	Required (IEC 68-1)	Actual
Temperature (°C)	15-35	20-35
Humidity (%RH)	25-75	50-65
Barometric pressure (mbar)	860-1060	950-1000

Site Description: April 22, 2001 File on
Federal Communications Commission

FCC Engineering Laboratory

7435 Oakland Mills Road

Columbia, MD 21046

Reference 31040/SIT1300F2

June 29, 2001 Accreditation on NVLAP

NVLAP Lab Code: 200533-0

Site Name: Quietek Corporation

Site Address: No. 5-22, Ruei-Shu Valley, Ruei-Ping Tsuen,
Lin Kou Shiang, Taipei 244 Taiwan, R.O.C.

TEL : 886-2-8601-3788 / FAX : 886-2-8601-3789

E-Mail : service@quietek.com



2. Conducted Emission

2.1. Test Equipment List

The following test equipment are used during the conducted emission test:

Item	Instrument	Manufacturer	Type No./Serial No	Last Cal..	Remark
1	Test Receiver	R & S	ESCS 30/838251/0001	May, 2001	
2	L.I.S.N.	R & S	ESH3-Z5/836679/0023	May, 2001	EUT
3	L.I.S.N.	R & S	ENV 4200/833209/0023	May, 2001	Peripherals
4	Pulse Limiter	R & S	ESH3-Z2	May, 2001	
5	No.4 Shielded Room			N/A	

Note: All equipment upon which need to calibrated are with calibration period of 1 year.

2.2. Test Setup

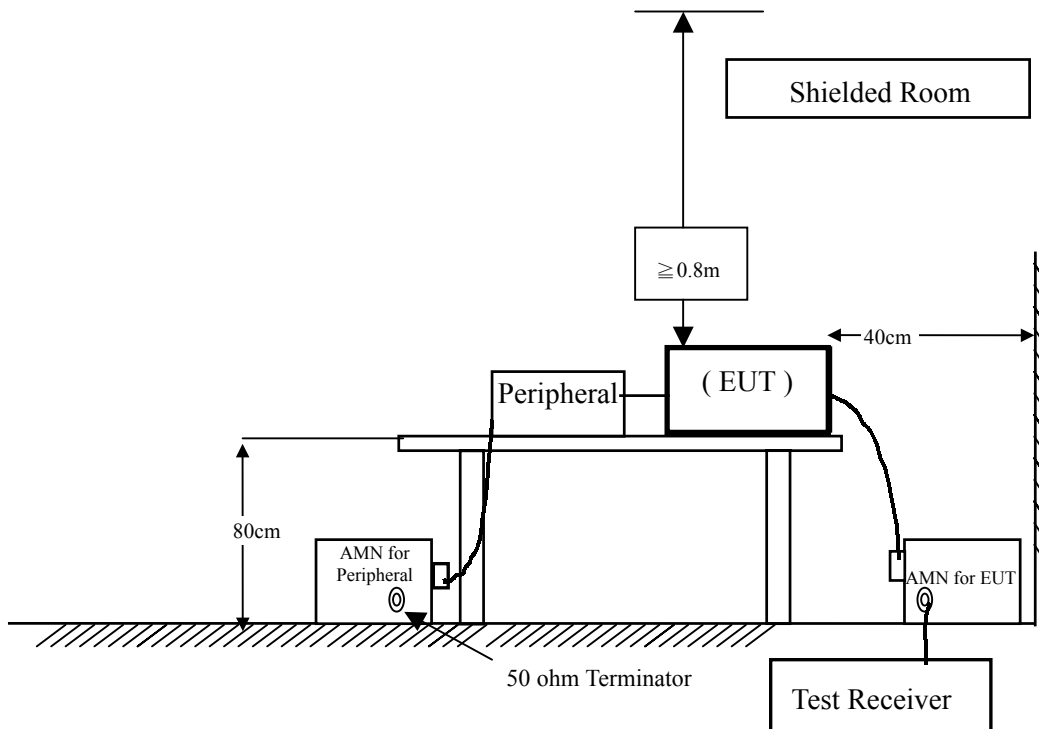

2.3. Limits

FCC Part 15 Paragraph 15.207 (dBuV)		
Frequency MHz	Limits	
	uV	dBuV
0.45 - 30	250	48.0

2.4. Test Procedure

The EUT and simulators are connected to the main power through a line impedance stabilization network (L.I.S.N.). This provides a 50 ohm /50uH coupling impedance for the measuring equipment. The peripheral devices are also connected to the main power through a LISN that provides a 50ohm/50uH coupling impedance with 50ohm termination. (Please refers to the block diagram of the test setup and photographs.)

Both sides of A.C. line are checked for maximum conducted interference. In order to find the maximum emission, the relative positions of equipment and all of the interface cables must be changed according to ANSI C63.4:1992 on conducted measurement.

Conducted emissions were invested over the frequency range from 0.45MHz to 30MHz using a receiver bandwidth of 9kHz.

2.5. Test Result

The emission from the EUT was below the specified limits. The worst-case emissions are shown in [section 5](#). The acceptance criterion was met and the EUT passed the test.

3. Radiated Emission

3.1. Test Equipment

The following test equipment are used during the radiated emission test:

Test Site	Equipment	Manufacturer	Model No./Serial No.	Last Cal.
<input checked="" type="checkbox"/> Site # 1	X Test Receiver	R & S	ESVS 10 / 834468/003	July, 2001
	X Spectrum Analyzer	Advantest	R3162/ 00803480	May, 2001
	X Pre-Amplifier	Advantest	BB525C/ 3307A01812	May, 2001
	X Horn Antenna	ETS	3115 / 0005-6160	July, 2001
	X Bilog Antenna	SCHAFFNER	CBL6112B / 2697	Nov., 2001
<input type="checkbox"/> Site # 2	X Test Receiver	R & S	ESCS 30 / 836858/022	Nov., 2001
	X Spectrum Analyzer	Advantest	3162 / 100803466	May, 2001
	X Pre-Amplifier	Advantest	BB525C/3307A01814	May, 2001
	X Bilog Antenna	SCHAFFNER	CBL6112B / 2705	Oct., 2001
	X Pre-Amplifier	QTK	QTK-AMP-01/ 0001	July, 2001

- Note:
1. All equipments that need to calibrate are with calibration period of 1 year.
 2. Mark "X" test instruments are used to measure the final test results.

3.2. Test Setup

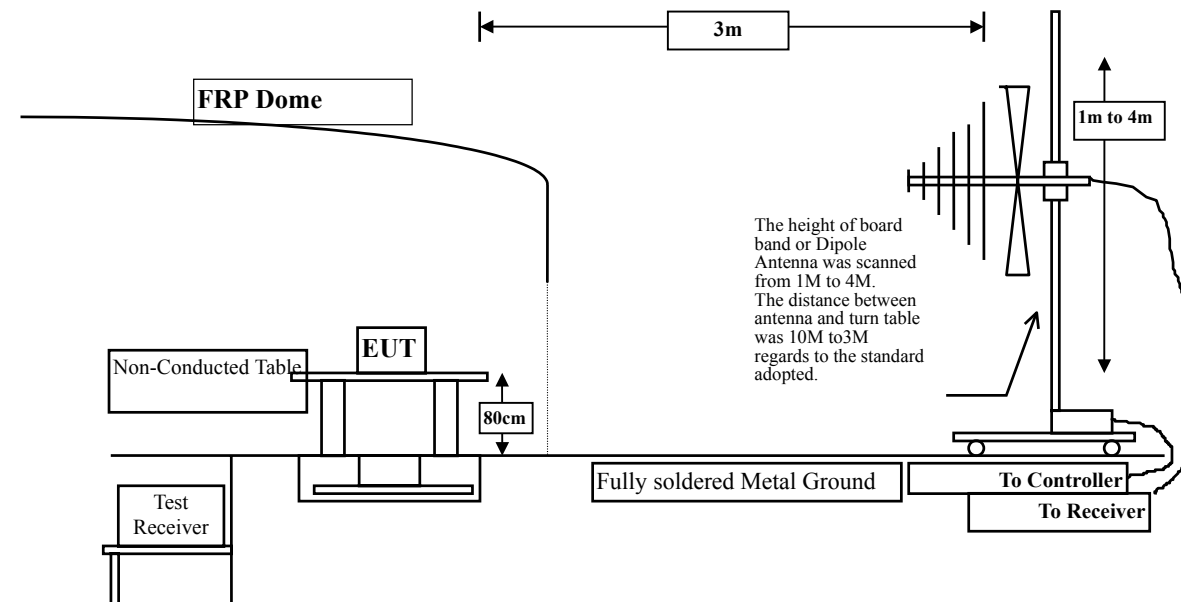

3.3. Limits

➤ FCC Part 15 Subpart C Paragraph 15.227 Limit

Fundamental Frequency MHz	Field strength of fundamental	
	uV/m	dBuV/m
26.96-27.28	10000	80.0

Remarks :

1. RF Voltage (dBuV) = 20 log RF Voltage (uV)
2. Distance refers to the distance in meters between the measuring instrument antenna and the closed point of any part of the device or system.

➤ Frequencies in restricted band are complied to limits on Paragraph 15.209.

Frequency MHz	15.209 Limits (dBuV/m @3m)
30-88	40
88-216	43.5
216-960	46
Above 960	54

Remarks :

1. RF Voltage (dBuV) = 20 log RF Voltage (uV)
2. In the Above Table, the tighter limit applies at the band edges.
3. Distance refers to the distance in meters between the measuring instrument antenna and the closed point of any part of the device or system.

3.4. Test Procedure

The EUT and its simulators are placed on a turn table which is 0.8 meter above ground. The turn table can rotate 360 degrees to determine the position of the maximum emission level. The EUT was positioned such that the distance from antenna to the EUT was 3 meters.

The antenna can move up and down between 1 meter and 4 meters to find out the maximum emission level.

Both horizontal and vertical polarization of the antenna are set on measurement. In order to find the maximum emission, all of the interface cables must be manipulated according to ANSI C63.4:1992 on radiated measurement.

Radiated emissions were investigated over the frequency range from 30MHz to 1GHz using a receiver bandwidth of 120kHz. Radiated was performed at an antenna to EUT distance of 3 meters.

The frequency range from 30MHz to 10th harmonics is checked.

3.5. Test Result

The emission from the EUT was below the specified limits. The worst-case emissions are shown in [section 5](#). The acceptance criterion was met and the EUT passed the test.

4. EMI Reduction Method During Compliance Testing

No modification was made during testing.

5. Summary of Test Datas

The test results in the emission was performed according to the requirements of measurement standard and process. Quietek Corporation is assumed full responsibility for the accuracy and completeness of these measurements. The test data of the emission is listed as below.

All the tests were carried out with the EUT in normal operation, which was defined as:

Test Mode: Normal Operation

The EUT passed all the tests.

5.1. Test Data of Conducted Emission

Owing to the DC operation of EUT, this test item in not performed.

5.2. Test Data of Radiated Emission

Product : RF cordless Mouse
 Test Item : Fundamental Radiated Emission Data
 Test Site : No.1 OATS
 Test Voltage : DC 3V (Battery)
 Test Mode : Normal Operation

Freq.	Cable	Probe	PreAMP	Reading	Emission	Margin	Limit
MHz	Loss	Factor		Level	Level		
	dB	dB/m	dB	dBuV	dBuV/m	dB	dBuV/m
27.126	1.50	0.00	0.00	33.50	35.00	45.00	80.00

Note:

1. All Readings are Average value.
2. Emission Level = Reading Level + Probe Factor + Cable loss.

Product : RF cordless Mouse
 Test Item : General Radiated Emission Data
 Test Site : No.1 OATS
 Test Voltage : DC 3V (Battery)
 Test Mode : Normal Operation

Freq.	Cable Loss	Probe Factor	PreAMP	Reading Level	Emission Level	Margin	Limit
MHz	dB	dB/m	dB	dBuV	dBuV/m	dB	dBuV/m
Horizontal							
40.572	0.92	13.11	0.00	7.09	21.12	18.88	40.00
54.260	0.99	6.24	0.00	22.26	29.49	10.51	40.00
* 56.270	1.00	5.93	0.00	26.55	33.48	6.52	40.00
80.384	1.14	7.90	0.00	14.73	23.76	16.24	40.00
120.582	1.33	11.62	0.00	11.53	24.49	19.01	43.50
132.638	1.40	11.49	0.00	13.83	26.72	16.78	43.50
144.696	1.47	10.66	0.00	9.83	21.95	21.55	43.50
165.979	1.57	9.12	0.00	10.04	20.73	22.77	43.50
196.951	1.73	8.20	0.00	6.99	16.92	26.58	43.50
250.001	2.01	11.81	0.00	5.55	19.37	26.63	46.00
525.034	3.41	16.44	0.00	15.47	35.33	10.67	46.00
550.660	3.56	18.16	0.00	6.99	28.71	17.29	46.00
Vertical							
40.572	0.92	12.68	0.00	13.62	27.22	12.78	40.00
* 54.254	0.99	5.90	0.00	21.98	28.87	11.13	40.00
80.384	1.14	7.22	0.00	16.02	24.38	15.62	40.00
120.573	1.33	10.66	0.00	12.44	24.43	19.07	43.50
132.633	1.40	10.55	0.00	15.83	27.78	15.72	43.50
196.943	1.73	8.14	0.00	12.09	21.96	21.54	43.50
204.978	1.77	8.56	0.00	8.52	18.85	24.65	43.50
432.068	2.95	17.36	0.00	8.92	29.23	16.77	46.00
544.085	3.52	18.49	0.00	2.27	24.28	21.72	46.00
576.094	3.69	19.37	0.00	1.83	24.89	21.11	46.00

Note:

1. All Reading Levels below 1GHz are Quasi-Peak, above are peak and average value.
2. “ * ”, means this data is the worst emission level.
3. Emission Level = Reading Level + Probe Factor + Cable loss.

Attachment 1 : EUT Test Photographs

Attachment 2 : EUT Detailed Photographs